

OWNERS PARTS LIST

CRAFTSMAN ENGINE

MODEL NUMBER: 143.586162

7 H.P.



SEARS, ROEBUCK AND CO. - U.S.A.

SIMPSONS-SEARS LIMITED, CANADA



Be Sure To Observe Safety Precautions To Prevent Accidents

1. **Stop the engine** whenever you leave the equipment, even for a moment. Make sure blades and all moving parts have stopped, disconnect the spark plug wire from the plug and keep wire away from plug to prevent accidental starting before cleaning, making any adjustments, inspecting or repairing.
2. **Check fuel** before each using. Do not fill gasoline tank when engine is running or while engine is hot. Wipe off any spilled gasoline before starting engine - - gasoline is highly flammable - always handle with care.
3. **Do not** run engine indoors, exhaust gases contain carbon monoxide which is odorless and deadly poison. If for some reason engine must be run indoors, open all doors and windows to provide sufficient ventilation.
4. **For engines** equipped with a No Pull Starter, be sure and read the handling and safety precautions in your engine manual.
5. **Disengage** self propelling unit or drive clutch on units so equipped before starting engine - - Keep guards in place.
6. **Don't change** governor settings or overspeed the engine. The governor controls the speed and protect the engine from damaging, excessive speeds. Excessive speeds are dangerous.
7. **Don't store** equipment with fuel in the tank inside a building where fumes may reach an open flame or spark. Let the engine cool before storing in any enclosure.
8. **Never leave** engine running unattended.
9. **Keep** all screws, nuts and bolts tight to be sure equipment is in safe operating condition. Keep equipment clean at all times.
10. If your equipment should start vibrating, stop the engine and check for damage or loose parts. Vibration generally is a warning of trouble.

IMPORTANT

1. **READ ALL INSTRUCTIONS CAREFULLY BEFORE OPERATING THIS ENGINE.**
2. **MAKE ONLY THE SIMPLE ADJUSTMENTS AS OUTLINED IN THIS BOOK.**
3. **FOR ANY MAJOR ADJUSTMENTS OR REPAIRS CONTACT YOUR NEAREST SEARS, ROEBUCK AND CO. OR SIMPSON-SEARS RETAIL, MAIL ORDER OR CATALOG SALES OFFICE STORE.**
4. **KEEP THIS BOOK HANDY AT ALL TIMES FOR FUTURE REFERENCE. READ IT CAREFULLY AND FAMILIARIZE YOURSELF WITH THE OPERATING AND MAINTENANCE INSTRUCTIONS. THIS BOOK ALSO CONTAINS A COMPLETE PARTS LISTING.**

CRAFTSMAN QUALITY ENGINE

GUARANTEE

We guarantee all Craftsman Engines to be free from defects in material and workmanship. When properly used, cared for, and maintained, we will replace at our option and install, without cost to you, for a period of one (1) year from date of sale, any part which proves, upon our examination, to be defective under normal use.

This guarantee does not cover adjustments to carburetors, ignition points, replacement of spark plugs, cleaning, sharpening of blades, or any service or adjustment made necessary by normal use and wear nor does it cover any failures which are a result of improper care, negligence, abuse, failure to lubricate properly or use of contaminated fuels or lubricants.

Damage resulting from striking solid or foreign objects (rocks, tree roots, sprinkler heads, iron pipe, walk edge, etc.) is not covered by this guarantee.

Equipment used for rental or commercial purposes is guaranteed only for thirty (30) days.

SEARS, ROEBUCK AND CO.

CUSTOMER'S RESPONSIBILITIES

Always use care when operating mechanical or powered equipment. Keep clear of moving parts, belts or chains. Do not work on equipment with the engine running. Avoid striking or running into solid objects or debris in the area to be worked. Clear the area of foreign objects such as: sticks, stones, wire, etc. Keep your equipment clean and check for loose bolts, nuts and fasteners. Check the engine oil regularly and change it as outlined in your engine manual.

Your guarantee is intended to provide you with adequate protection against failures due to defects in material or workmanship but it does not cover adjustments or replacement of parts due to normal wear or use nor does it cover damage that may result in use.

BEFORE STARTING ENGINE

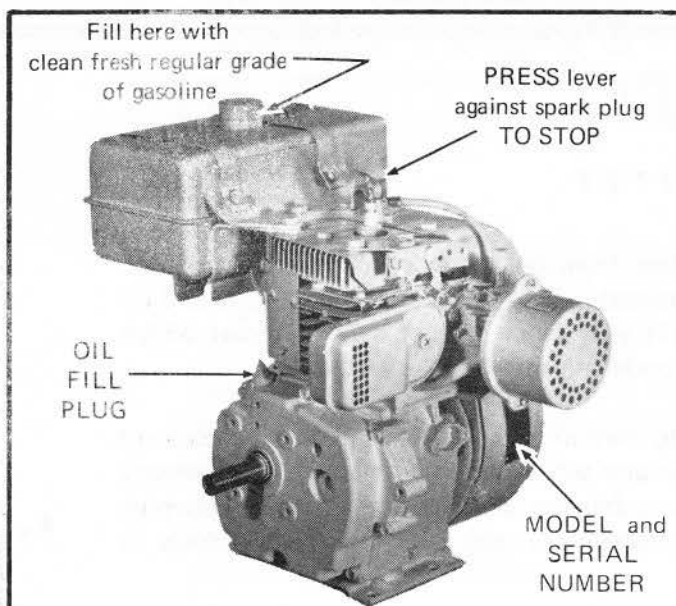

1. Before starting, fill crankcase with 1-3/8 pint of oil or to top of filler neck or to "Full" mark when dip stick is provided. Be sure dip stick is screwed in and that engine is level.
2. Use Allstate M.S. S.A.E. # 30 oil or equivalent. If not available, use Allstate Multi-Grade All-Weather oil (S.A.E. 10W-20W-30W) or equivalent.
3. In climates where it is cool in the spring and fall, the above All-Weather oil will produce easier starting.
4. Change oil after first 2 hours of operation and every 25 operating hours thereafter. Check oil every 8 operating hours.

TO START ENGINE

CAUTION: Before doing anything make sure your hands and feet are clear of all moving parts.

- 1 To start your engine when it is cold, move the control lever into "CHOKE" position.
- 2 Grasp recoil starter handle and pull sharply. Do not allow starter rope to snap back. Rewind slowly keeping hold of the starter handle at all times.
- 3 After engine starts move the control out of "CHOKE" and into the "FAST" position

NOTE: If your engine is warm, start with the control in the "FAST" position (i.e.- do not choke).

TO STOP ENGINE

- 1 To stop engine press stop lever against spark plug and hold until engine stops. Fig. 1.

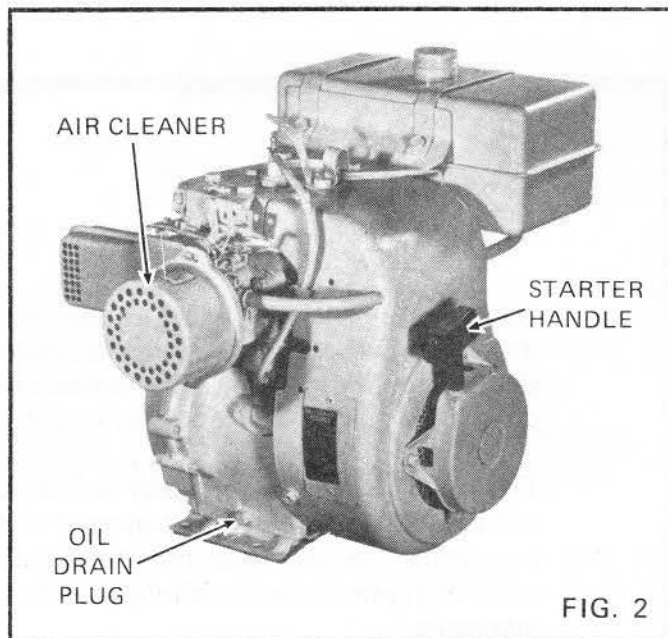

SERVICE INSTRUCTIONS

To obtain longest life and trouble free use of your engine, certain normal maintenance must be performed as outlined below:

Disconnect spark plug wire at spark plug before performing any maintenance to prevent accidental starting of engine.

CHANGE OIL

- 1 Change oil in engine crankcase after first two hours of operation. Unscrew oil drain plug located on end of engine base. (See Fig. 1).
- 2 Replace oil drain plug and refill engine crankcase with oil as per instructions in Fig. 1.
- 3 Thereafter check oil level often, before each using, at each eight hours of operation and add oil if necessary to bring up to proper level. (See Fig. 1).
- 4 Change oil at each 25 hours of operation.

PROPER FUEL

Use a good grade of fresh CLEAN Regular gasoline.

CLEAN ENGINE

- 1 Wipe off all spilled fuel and oil.
- 2 Keep engine clean of foreign matter at all times. Be sure air fins on Cylinder are kept clean to permit proper ventilation. Remember, this is an air cooled engine and free air flow is important for proper engine performance and life.

SERVICE AIR CLEANER

You must SERVICE YOUR AIR CLEANER. The air cleaner prevents damaging dirt, dust, etc., from entering the carburetor and being forced into the engine and is paramount in importance to engine life and performance.

This engine is equipped with a serviceable air cleaner with a removable polyurethane element which you can clean simply as follows: (See Figs. 2 & 3).

To clean, loosen screws that hold air filter body to bracket. Twist body and lift body from bracket, then proceed as follows:

a. PULL ELEMENT OUT OF BODY.

b. WASH ELEMENT.

- (1) Wash in gasoline, or strong solution of water and household detergent.
- (2) CAUTION: If gasoline is used, keep away from fire or flame and burning cigarettes. Clean outdoors.

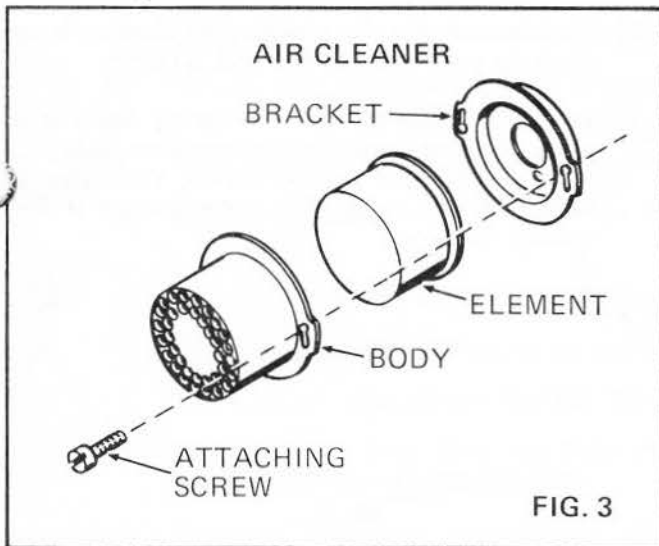

c. DRY ELEMENT BY SQUEEZING like sponge or with compressed air if available.

d. Coat element with about two tablespoons of oil and knead into element to spread. Then squeeze to remove any excess oil.

e. Clean Air Cleaner body and bracket with same solution that you cleaned element with. Dry thoroughly.

f. Reassemble. See Fig. 3.

- (1) Insert Element into body.
- (2) Place body into bracket. Twist body, tighten screws.

NEVER RUN YOUR ENGINE WITHOUT AIR CLEANER COMPLETELY ASSEMBLED.

CARBURETOR ADJUSTMENT

Do not make unnecessary adjustments. Factory settings are correct for most applications. If adjustments are needed proceed as follows:

- 1 After making initial adjustments as shown (Fig. 4) start engine.
- 2 Turn "High Speed adjusting Needle" forward or back 1/8 turn at a time until engine runs smoothly. If engine tends to stall when unit is in use open needle 1/8 turn.
- 3 Hold throttle lever in idle position.
- 4 Turn "Idle Adjusting Needle" forward or back 1/8 turn at a time until engine runs smoothly.

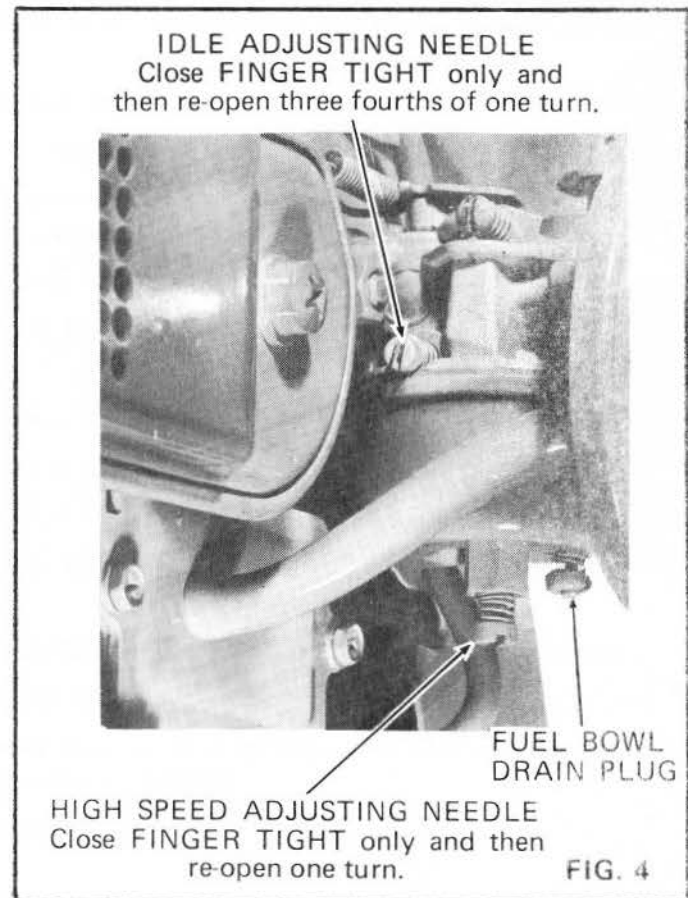

- 5 Allow several seconds between each adjustment for engine carburetor to react to the new setting.

CAUTION: Never attempt to change maximum engine speed. This is preset at factory and can only be changed by a qualified Service repairman who has the necessary equipment.

CHECK SPARK PLUG

- 1 Remove the spark plug each time you change oil and inspect it.
 - (a) The electrodes should be kept clean and free of carbon. The presence of carbon or excess oil will greatly deter proper engine performance.
 - (b) If possible, check the spark plug gap (area between electrodes) using a wire feeler gauge. This specification should be .030.

2 If you need a new Spark Plug refer to the parts list for the proper replacement Spark Plug.

3 Before installing Spark Plug coat threads lightly with Graphite Grease if possible to insure easy removal next time the Spark Plug needs inspection.

STORAGE INSTRUCTIONS

- 1 If you are going to store your engine for any length of time (30 days or longer or at the end of the season) you must:
 - a. DRAIN THE GAS TANK.

- b. DRAIN THE CARBURETOR by allowing engine to run out of gas. Gasoline left in your engine will leave gum deposits in the carburetor and gas tank. This makes fuel system inoperative and will result in hard or non-starting of the engine.
- c. CLEAN ENGINE of all foreign matter.
- d. LUBRICATE CYLINDER by removing the spark plug and pouring one ounce of clean lubricating oil through the spark plug hole into the cylinder. Crank the engine slowly to spread oil and replace Spark Plug.

GENERAL

- 1 Just as your automobile needs professional mechanical maintenance from time to time, so does your air cooled engine. Cleaning and adjusting of the Carburetor and periodic replacement of the Spark Plug and Ignition Points is made necessary by NORMAL use.
- 2 Professional Air Cooled Engine Service is as close as your nearest SEARS STORE.
- 3 A yearly check-up or tune-up by Sears is a good idea to avoid breakdowns or delay... do it at the end of the season, then you're ready for the next. We even prepare it for storage for you.

SERVICE TIPS

REFERENCE TO THIS SECTION MAY HELP AVOID A DELAY IN YOUR WORK OR SAVE THE EXPENSE OF A SERVICE CALL.

Q The engine won't start or is hard to start. What can I do?

- A**
1. You're not out of gas are you? It happens sometimes.
 2. Is the spark plug wire attached to the plug?
 3. Check the spark plug porcelain, maybe it is cracked.
 4. The spark plug may be fouled; clean the electrodes and reset the plug gap; instructions are under "CHECK SPARK PLUG" in this manual.
 5. Is the gas line obstructed? Remove fuel line at carburetor and check for obstruction. Drain gas tank and replace with clean, fresh gasoline.
 6. Is the fuel clean? You didn't use a dirty or rusty gas can did you? If you did, it might be better to let Sears check the fuel system and carburetor.
 7. Stale gas that has set around and lost its strength is a trouble maker . . . hard starting and loss of power results.
 8. Maybe there is water in the gas. Condensation in the tank or in your gas can sometimes happens.
 9. Carburetor could be out of adjustment . . . check "CARBURETOR ADJUSTMENT" in manual.
 10. Maybe you over-choked and flooded the engine. Put throttle in run or fast position and crank several times to clear out the excess gas.
 11. Your throttle control may be set so that it does not fully close the choke.
 12. Dirty or plugged air cleaner? See "SERVICE INSTRUCTIONS" in this manual.

Q My engine misses or lacks power under load. What might cause this?

- A**
1. Your throttle control could be set too close to choke position and flooding the engine.
 2. Spark plug? See under "HARD TO START". Maybe it needs cleaning or replacing.
 3. Water in the fuel does not help the engine to run very good and robs it of power. See under "HARD TO START".
 4. Improper carburetor adjustment. Check "CARBURETOR ADJUSTMENT" in this manual.
 5. Got enough oil in crankcase? Low oil level or dirty oil makes trouble.
 6. A partially plugged air cleaner will restrict the air flow to the carburetor and reduce power. See manual. The engine breathes through the air cleaner.
 7. Don't put oil in the gas. It reduces the efficiency of the engine.

Q The engine seems to overheat. What should I do?

- A**
1. Be sure you have plenty of oil in the crankcase and that it is clean. When did you change last?
 2. Check the oil level in your crankcase. Low oil level will cause overheating.
 3. Sometimes the muffler can get plugged. This causes back pressure, over-heating and loss of power.

CRAFTSMAN 4-CYCLE ENGINE

MODEL NUMBER: 143.586162

BASIC ENGINE

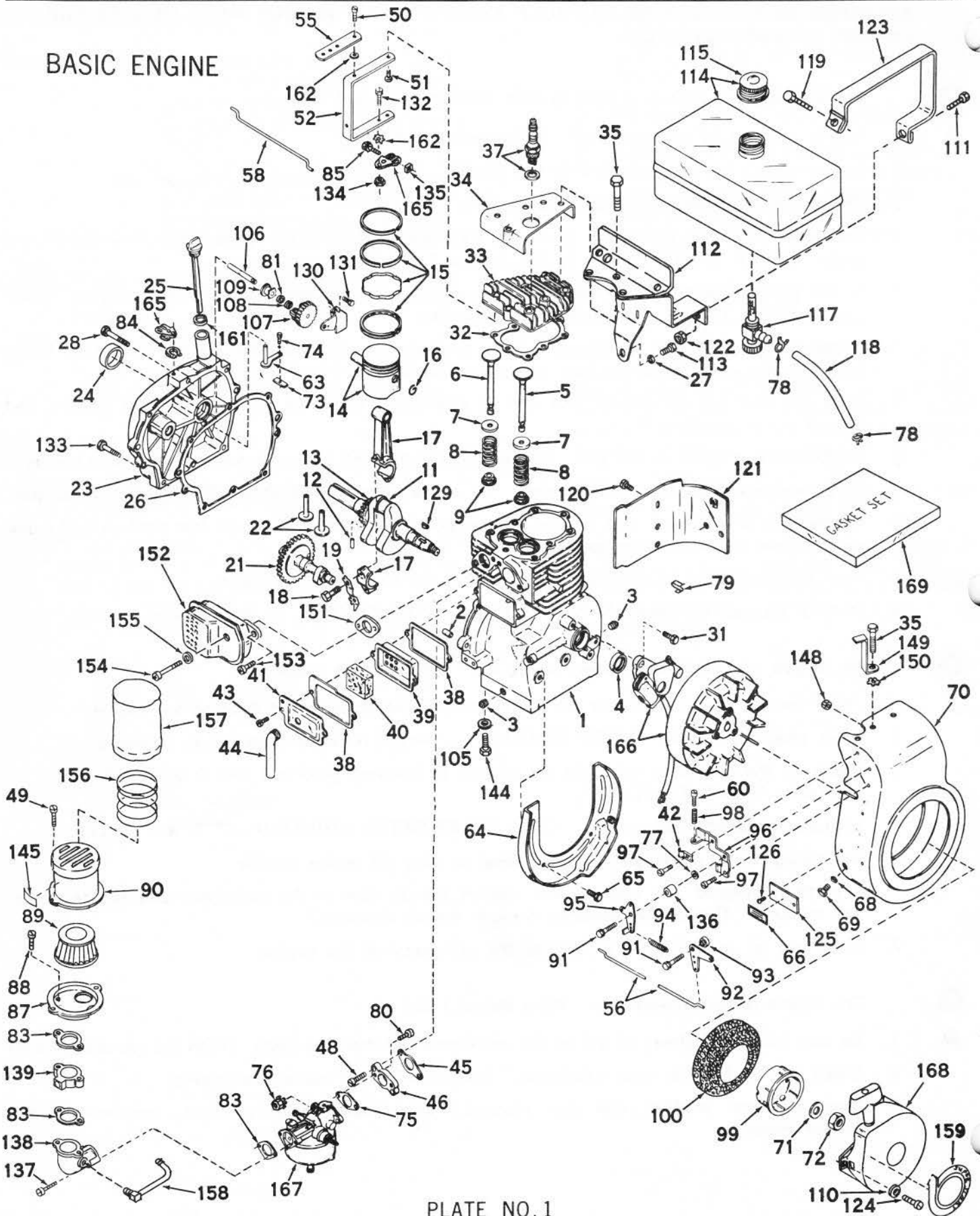

PLATE NO. 1

PARTS LIST

CRAFTSMAN 4-CYCLE ENGINE

MODEL NUMBER: 143.586162

Ref. No.	Part No.	Part Name
1	32586	Cylinder Assembly (Incl. Nos. 2, 3 & 4)
2	27652	Pin, Dowel
3	27642	Plug, Sq. hd. pipe (oil drain)
4	*32630	Seal, Oil
5	32783	Valve, Intake (Standard) (Incl. No. 9)
5	32784	Valve, Intake (1/32" oversize) (Incl. No. 9)
6	27878A	Valve, Exhaust (Standard) (Incl. No. 9)
6	27880A	Valve, Exhaust (1/32" oversize) (Incl. No. 9)
7	27882	Cap, Upper valve spring
8	27881	Spring, Valve
9	32581	Cap, Lower valve spring
11	32587	Crankshaft Assembly (Incl. Nos. 12 & 13)
12	29783	Pin, Groove
13	27884	Gear, Crankshaft
14	32592	Piston & Pin Assembly (Standard) (Incl. 2 of No. 16)
14	32593	Piston & Pin Assembly (.010 oversize) (Incl. 2 of No. 16)
14	32594	Piston & Pin Assembly (.020 oversize) (Incl. 2 of No. 16)
15	32595	Ring Set, Piston (Standard)
15	32596	Ring Set, Piston (.010 oversize)
15	32597	Ring Set, Piston (.020 oversize)
16	27888	Ring, Piston pin retaining
17	32591	Rod Assembly (Incl. Nos. 18 & 19)
18	650662	Screw, Connecting rod
19	32590	Dipper, Oil
21	32115	Camshaft
22	27893	Lifter, Valve
23	31577B	Cover, Cylinder (Incl. Nos. 24 & 106)
24	*28427	Seal, Oil
25	29668	Dipstick, Oil (Incl. No. 161)
26	*30684	Gasket, Cylinder cover
27	8303	Lockwasher, Heavy, split, 1/4"
28	650488	Screw, Hex hd. Sems, 1/4-20 x 1-1/4
31	650489	Screw, Hex hd. Sems with flat washer, 1/4-20 x 3/4
32	*32631	Gasket, Cylinder head
33	30938A	Head, Cylinder
34	30939	Cover, Cylinder head
35	28261	Screw, Hex hd. cap, 5/16-18 x 2-1/2
37	21943	Plug, Spark (Allstate #60130 or equivalent)
38	*27896	Gasket, Valve spring cover
39	28423	Body Assembly, Breather
40	28424	Element, Breather

Ref. No.	Part No.	Part Name
41	28425	Cover, Valve spring
42	27793	Clip, Conduit
43	650128	Screw, Fil. hd. Sems, 10-24 x 1/2
44	27627	Tube, Breather
45	*27915	Gasket, Intake
46	30195A	Flange, Carburetor
48	30196	Screw, Phil. fil. hd. mach., 5/16-18 x 3/4
49	650152	Screw, Fil. hd. Sems, 8-32 x 3/8
50	650548	Screw, Fil. slotted hd. S. T., 8-32 x 3/8
51	30319	Rivet, Split
52	31709	Lever, Governor
55	30205	Bracket, Governor adjusting
56	31879	Link, Governor lever-to-bell crank
58	30206	Link, Governor-to-throttle
60	28379	Screw, Speed adjusting
63	30699A	Rod Assembly, Governor
64	29536	Baffle, Blower housing
65	650561	Screw, Hex hd. cap, Sems, 1/4-20 x 5/8
66	30592	Decal, Instruction
68	8274	Lockwasher, 5/16"
69	29747	Screw, 5/16-24 x 3/4
70	31293	Housing, Blower
71	650490	Washer, Belleville
72	8116	Nut, Crankshaft
73	30700	Yoke, Governor
74	650494	Screw, Phil. fil. hd. Sems, 6-40 x 5/16
75	*31688	Gasket, Carburetor
76	29752	Nut, Lock, 1/4-28
77	28562	Bushing
78	26460	Clamp, Fuel line
79	27275	Clip, Wire
80	650572	Screw, Flat hd. Sems, 1/4-28 x 1-1/8
81	30590A	Washer, Flat
83	*27272	Gasket, Air cleaner
84	29642	Ring, Retaining
85	29826	Screw, Hex washer hd., 10-32 x 3/4
87	31691	Bracket, Air cleaner
88	650521	Screw, Phil. fil. hd. Sems, 10-32 x 1-1/8
89	30727	Element, Air cleaner
90	31715	Body Assembly, Air cleaner
91	30312	Screw, Hex slotted washer hd. Sems, 10-32 x 1/2
92	30712	Lever, Bell crank
93	29530	Bushing, Bell crank

*Indicates Parts Included in Gasket Set, Ref No. 169.

CRAFTSMAN 4-CYCLE ENGINE

MODEL NUMBER: 143.586162

Ref. No.	Part No.	Part Name
94	30202	Spring, Extension
95	30201	Lever, Speed control
96	30199	Bracket, Speed control
97	650399	Screw, Fil. hd. Sems, 10-32 x 5/8
98	28569	Spring, Compression
99	32125	Cup, Starter
100	590417	Screen, Starter cup
105	8274	Washer
106	31845	Shaft, Mechanical governor
107	30591	Gear Assembly, Governor
108	29193	Ring, Retaining
109	30588A	Spool, Governor
110	650168	Washer, Flat
111	6202	Screw, Hex hd. cap, 1/4-28 x 1
112	31694	Bracket, Fuel tank
113	29715	Screw, Hex hd. cap, 1/4-20 x 5/8
114	31301	Tank Assembly, Fuel (Incl. No. 115)
115	32387	Cap, Fuel tank
117	29683	Strainer & Shut-off Valve, Fuel
118	30705	Line, Fuel
119	29212	Screw, Hex hd. Sems, 1/4-28 x 7/16
120	650128	Screw, Fil. hd. Sems, 10-24 x 1/2
121	30622	Extension, Blower housing
122	29752	Locknut, Hex, 1/4-28
123	31697	Strap, Fuel tank
124	30513	Screw, Phil. fil. hd. Sems, 1/4-28 x 1/2
125	31345	Plate, Identification
126	29309	Stud, Drive
129	32589	Key, Flywheel
130	31843A	Bracket, Governor
131	28763	Screw, Slotted hex hd., 10-24 x 7/16, thr'd cutting
132	650548	Screw, Hex slotted washer hd., 8-32 x 3/8

Ref. No.	Part No.	Part Name
133	650493	Screw, Hex hd. Sems, 1/4-20 x 1-3/4
134	30322	Nut, Lock, 8-32
135	29216	Nut, Square, 10-32
136	29530	Bushing, Control lever
137	28597	Screw, Fil. hd. Sems, 10-32 x 3/4
138	30708	Elbow, Air cleaner
139	30936	Spacer, Air cleaner
144	650185	Screw, Hex hd. cap, 5/16-18 x 1
145	31752	Decal, Air cleaner
148	30529	Locknut, 10-32
149	30747	Clip, Spark plug shorting
150	16645	Lockwasher, 5/16 E. T.
151	27930	Gasket, Muffler
152	32401	Muffler
153	30196	Screw, Phil. fil. hd. mach., 5/16-18 x 3/4
154	6023	Screw, Hex hd. cap, 5/16-18 x 2
155	26073	Washer, Flat
156	31667	Spring, Pre-cleaner bag
157	31668	Bag, Pre-cleaner
158	30709	Fitting, Breather
159	32179	Decal, Super-start
161	*29673	Gasket, Dipstick
162	29918	Lockwasher, No. 8 E. T.
165	29916	Clamp, Governor
166	610689A	Magneto (See Plate No. 2)
167	631453	Carburetor (See Plate No. 3)
168	590420	Starter Assembly, Rewind (See Plate No. 4)
169	32658	Gasket Set (Incl. items marked *)
	691822	Owners Parts List

*Indicates Parts Included in Gasket Set, Ref. No. 169.

CRAFTSMAN 4-CYCLE ENGINE

MODEL NUMBER: 143.586162

Magneto No. 610689A

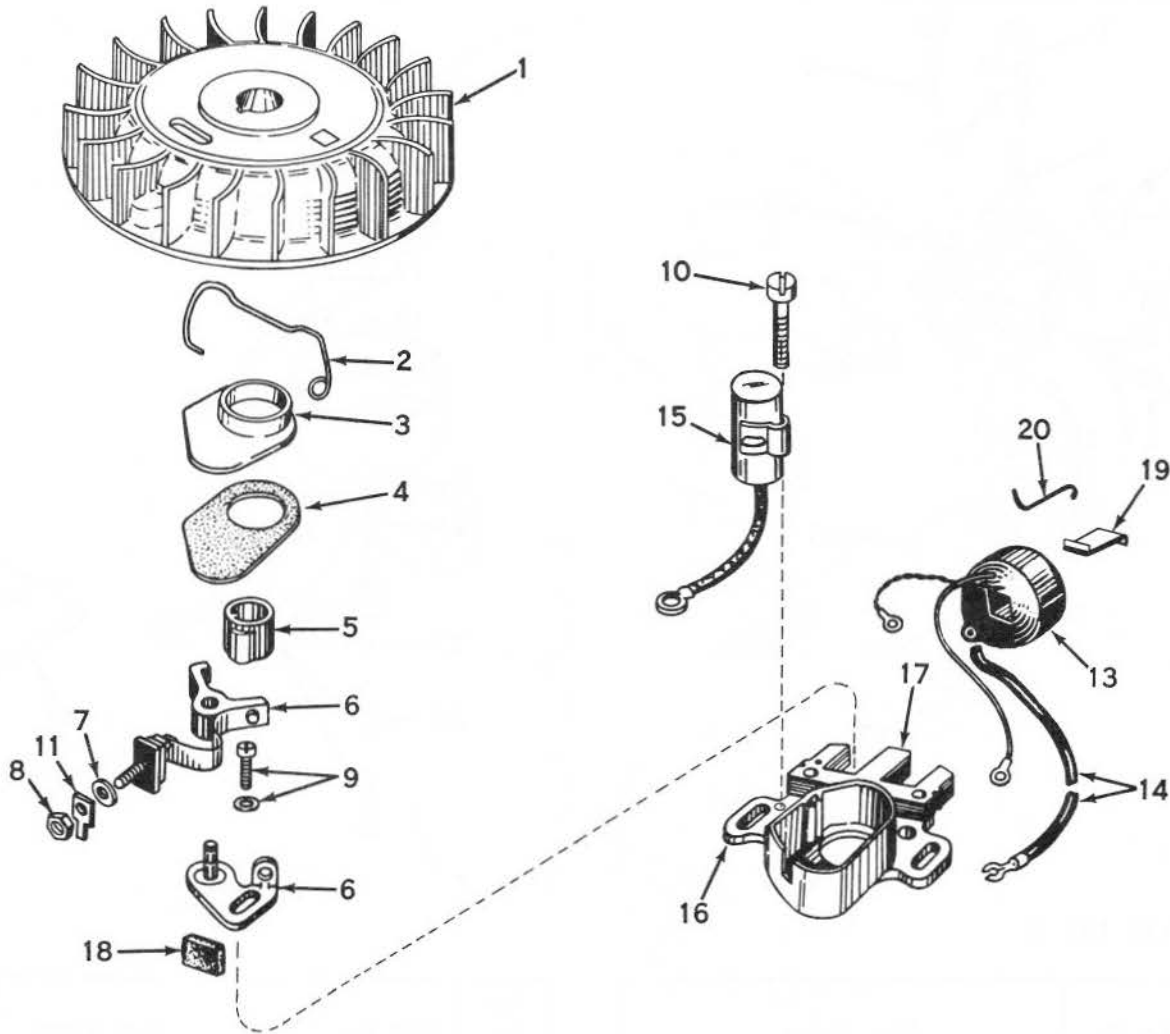

PLATE NO. 2

Ref. No.	Part No.	Part Name
	610689A	Magneto
1	30555	Flywheel
2	30551	Spring, Breaker box dust cover
3	30550	Cover, Breaker box dust
4	30883	Gasket, Dust cover
5	30992	Cam, Breaker
6	30547A	Breaker Assembly
7	610385	Washer, Terminal
8	610408	Nut, Terminal
9	29181	Screw and Washer Assembly, Breaker

Ref. No.	Part No.	Part Name
10	610593	Screw, Condenser fastening
11	30843	Tab, Ground terminal
13	30560	Coil Assembly (Incl. Ref. Nos. 14, 15 & 19)
14	30554	Wire, Ignition lead
15	30548A	Condenser
16	30545	Core and Plate Group
17	30561A	Stator Assembly
18	30549	Felt, Cam wiper
19	29629	Spring, Coil wedge
20	31311	Clip, Coil locking

CRAFTSMAN 4-CYCLE ENGINE

MODEL NUMBER: 143.586162

Carburetor No. 631453

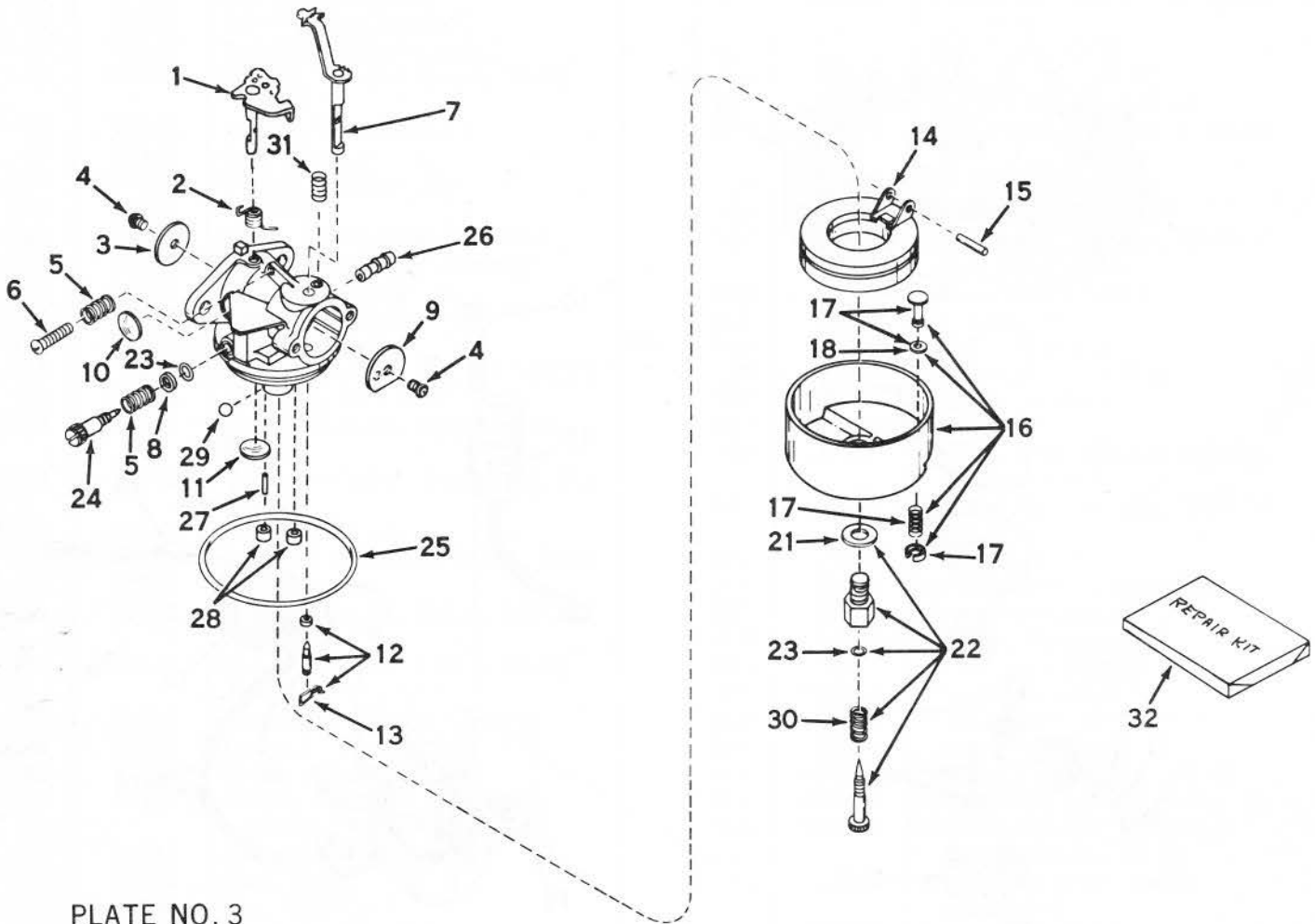

PLATE NO. 3

Ref. No.	Part No.	Part Name
	631453	Carburetor
1	31834	Shaft & Lever Assy., Throttle
2	630731	Spring, Throttle return
3	631036	Shutter, Throttle
4	650506	Screw, 4-40 x 3/16
5	630766	Spring, Idle regulating screw
6	650417	Screw, Idle regulating
7	31836	Shaft & Lever Assy., Choke
8	630739	Washer, Flat
9	31837	Shutter, Choke
10	630748	Plug, Welch
11	631027	Plug, Welch
12	*631021	Inlet Needle, Seat & Clip Assy. (Incl. No. 13)
13	631022	Clip, Inlet needle
14	631023	Float, Carburetor
15	*631024	Shaft, Float
16	631025	Bowl & Drain Assy., Float (Incl. No. 17)

Ref. No.	Part No.	Part Name
17	27136A	Plunger Assy., Drain (Incl. No. 18)
18	27554	Gasket, Drain plunger
21	*27110	Gasket, Bowl-to-body
22	*31839	Adjustment Screw Assy., Main (Incl. Nos. 21, 23 & 30)
23	630740	"O" Ring, Adjustment screw
24	*631078	Screw, Idle adjustment
25	*631028	Gasket, Bowl-to-body
26	31838	Fitting, Fuel inlet
27	631039	Pin
28	630747	Plug, Cup
29	631081	Ball, Aluminum
30	630738	Spring, Main adjustment screw
31	630735	Spring, Choke stop
32	31840	Repair Kit (Incl. items marked *)

CRAFTSMAN 4-CYCLE ENGINE

MODEL NUMBER: 143.586162

Rewind Starter No. 590420

NOTE: No-Pull Starter #590365 can be installed in place of original equipment starter if desired.

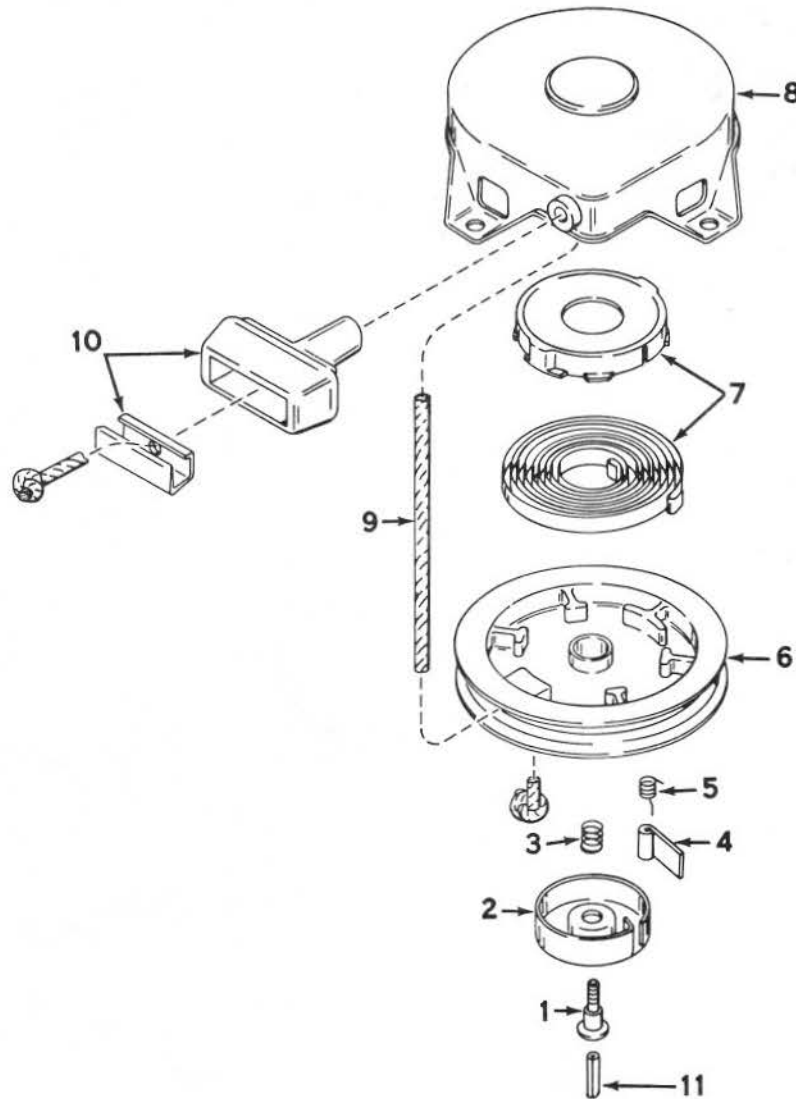

PLATE NO. 4

Ref. No.	Part No.	Part Name
1	590409	Screw, Retainer
2	590410	Retainer, R.H.
3	590411	Spring, Brake
4	590148	Dog, Starter
5	590412	Spring, R.H. dog
6	590413A	Pulley

Ref. No.	Part No.	Part Name
7	590414	Spring & Keeper Assy.
8	590415	Housing Assy., Starter
9	590386	Rope, Starter
10	590387	Handle Assy., Starter
11	590459	Pin, Centering

Faint, illegible text in the first large rectangular box.

Faint, illegible text in the second large rectangular box.

Faint, illegible text in the third large rectangular box.

Faint, illegible text in the fourth large rectangular box.

COAST TO COAST NATION-WIDE

SERVICE FROM SEARS

FOR YOUR CRAFTSMAN ENGINE



SEARS, ROEBUCK AND CO. and SIMPSONS-SEARS, LIMITED in Canada back up your investment with quick mechanical service and genuine replacement parts.

If and when you need repairs or service, call on us to protect your investment in this fine piece of equipment.

ENGINE MODEL NUMBER

The Model Number shown on the cover page will be found on a plate attached to the cylinder. Always mention the model number in all correspondence regarding the Craftsman engine.

EQUIPMENT MODEL NUMBER

For Equipment Parts List see owners manual.

HOW TO ORDER REPAIR PARTS

All parts listed herein may be ordered through SEARS, ROEBUCK AND CO. or SIMPSONS-SEARS, LIMITED. When ordering parts by mail from the catalog sales unit which serves the territory in which you live, selling prices will be furnished on request or parts will be shipped at prevailing prices and you will be billed accordingly.

WHEN ORDERING REPAIR PARTS, ALWAYS GIVE THE FOLLOWING INFORMATION AS SHOWN IN THIS LIST:

1. The PART NUMBER.
2. The PART NAME.
3. The MODEL NUMBER OF THE ENGINE.

SEARS, ROEBUCK AND CO. - U.S.A.

SIMPSONS-SEARS LIMITED, CANADA