

The following catalog has gaps in its page numbers, or doesn't have any numbers. We have chosen to leave the page numbering in the order that Acrobat assigns it.

PROPERTY
SERVICE PARTS
DEPARTMENT
DO NOT REMOVE

Onan

Parts Manual

B48M-GA018 Industrial Engines

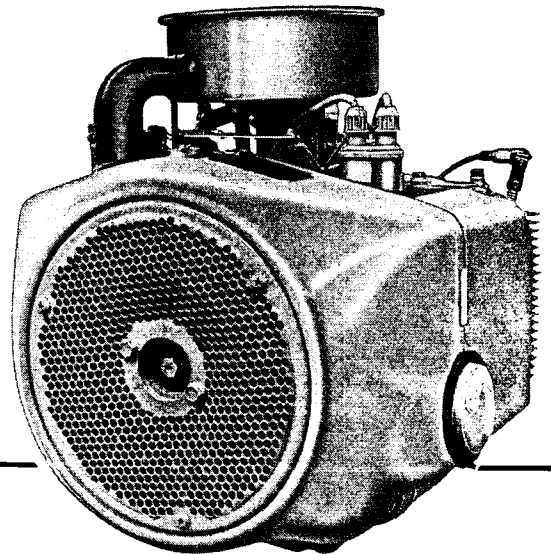

965-0255
11-88 (Spec A)
Replaces 8-85 (Spec A)

General Information

For parts or service, contact the dealer from whom you purchased this equipment or refer to your Nearest Authorized Onan Parts and Service Center.

To avoid errors or delay in filling your parts order, always give the MODEL, SPEC NO. and SERIAL NO. from the Onan nameplate.

The diagram shows a rectangular nameplate with two circular mounting holes at the top. The word "Onan" is printed in a large, bold, stylized font. Below the logo is a wide rectangular box labeled "MODEL AND SPEC NO.". Below that is a narrower rectangular box labeled "SERIAL NO.". The bottom right corner of the nameplate is shown as being folded over.

M-1149

For handy reference, insert "YOUR" nameplate information in the spaces above.

Index

- Adapter, Carburetor 44
Adapter, Exhaust (Flange Type) 48
Adapter, Governor Arm 24
Adapter, Oil Filter 12,35
Ammeter, DC 33,34
Arm, Governor Control 25
Armature, Starter 20,36
- Baffle, Breather Valve 4
Ball, Governor 8
Base, Oil 12
Bearing, Camshaft 4
Bearing, Crankshaft 4
Bearing, Sleeve 9
Block, Cylinder 4
Block, Terminal 42
Box, Breaker 18,19,41
Bracket, Governor Control 10,24
Bracket, Lifting 46
Brush, Ground-Starter 20,36
- Cable, Choke 33,34
Cable, Spark Plug 18,43
Camshaft 8
Cap, Fuel Tank 32
Carburetor Components, Gasoline 16,28,37,38
Carburetor, Gasoline 14,26
Clamp, Muffler 48
Clutch 31
Coil, Ignition 18
Coil, Magneto Stator 43
Condenser 19
Cover, Air-Cleaner 14,46
Cover, Breaker Box 19,41
Cover, Dust-Starter 20,36
Cover, Valve 4
Crankshaft 9
- Drain, Oil Filter 12
- Elbow, Air Intake 44
Element, Air Cleaner 14
- Filter, Air 14
Filter, Breather Tube 14,44
Filter, Fuel 39
Filter, Oil 12,46
Flywheel 9
- Gasket, Air Cleaner 14
Gasket, Breaker Box 19,41
Gasket, Cylinder Head 4
Gasket, Gearcase 7
Gasket, Oil Base 12
Gasket, Oil Filter Adapter 12
Gasket, Valve Cover 4
Gauge, Oil Pressure 33,34
Gear, Camshaft 8
Gear, Crankshaft 9
Gear, Ring 9
Gearcase 7
Governor 10
Guard, Flywheel 9,46
Guide, Valve 4
- Harness, Wiring 34
Head, Cylinder 4
Holder, Brush 20,36
Hose, Fuel 14,26
Housing, Air 11
Housing, Air Cleaner 14
- Housing, Blower 11
Housing, Clutch 46
Housing, Cylinder 11
Housing, Starter 20,36
Hub, Governor Cup 8
- Ignition, Magneto 43
- Kit, Adapter - Remote Air Cleaner 44
Kit, Alternator Connector 22,23
Kit, Fuel Tank 32
Kit, Gasket - Engine 4
Kit, Gasket - Oil Pump 12
Kit, Repair - Carburetor 16,28,37,38
Kit, Repair - Starter 20,36
Kit, Tuneup - Ignition 19
- Lever, Choke 40
Lever, Throttle Control 34
Line, Fuel - Gasoline 32
Line, Oil 33,34
- Manifold, Exhaust 48
Manifold, Intake 14
Muffler, Exhaust 48
- Numerical Index 49,50,51,52
- Panel, Control 33,34
Pipe, Exhaust 48
Piston 6
Plate, Bearing - Rear 4
Plug, Spark 18,43
Point Set, Breaker 19,41
Pulley, Alternator Drive 46
Pump, Fuel - Vacuum (Gasoline) 16,26,30
Pump, Oil 12
- Regulator, Voltage 22,23
Relay, Start Solenoid 20,36
Ring, Piston 6
Rod, Connecting 6
Rod, Control 10
- Seal, Air Filter 12
Seal, Oil 4,7
Seat, Valve 4
Shaft and Arm, Governor 7
Shaft, PTO 9
Sheave, Rope 9
Spring, Governor 10,24,25,33,34
Spring, Valve 4
Starter Components 20,36
Stator 22,23,43
Strap, Fuel Tank 32
Switch, Ignition 33,34
Switch, Pressure - Oil 46
- Tank, Fuel 32,46
Tappet, Valve 4
Tube, Air Intake 14,46
Tube, Breather 14,44
Tube, Oil 4
Tube, Vacuum Port 4,7
- Valve, Exhaust 4
Valve, Intake 4
Valve, Shut-Off 32
- Wrapper, Filter Element 46

Introduction

This catalog applies to the Standard B48M-GA018 Engines. Parts are arranged in groups of related items. Each illustrated part is identified by a reference number corresponding to the same reference number in the parts list for that group. Parts illustrations are typical. Using the MODEL and SPEC NO. from the nameplate, select the Parts that apply to your engine. Unless otherwise mentioned in the description, parts are interchangeable between models. Right and left sides are determined by facing the blower end (front) of the engine.

WARNING

This engine is not designed or intended for use in any type of aircraft. Use of this engine in aircraft may result in engine failure and cause serious bodily injury, death and/or property damage.

NOTICE !

Items referenced as optional indicate part is factory installed and may not be applicable to all models. For field conversions additional parts are usually required.

Cylinder Block

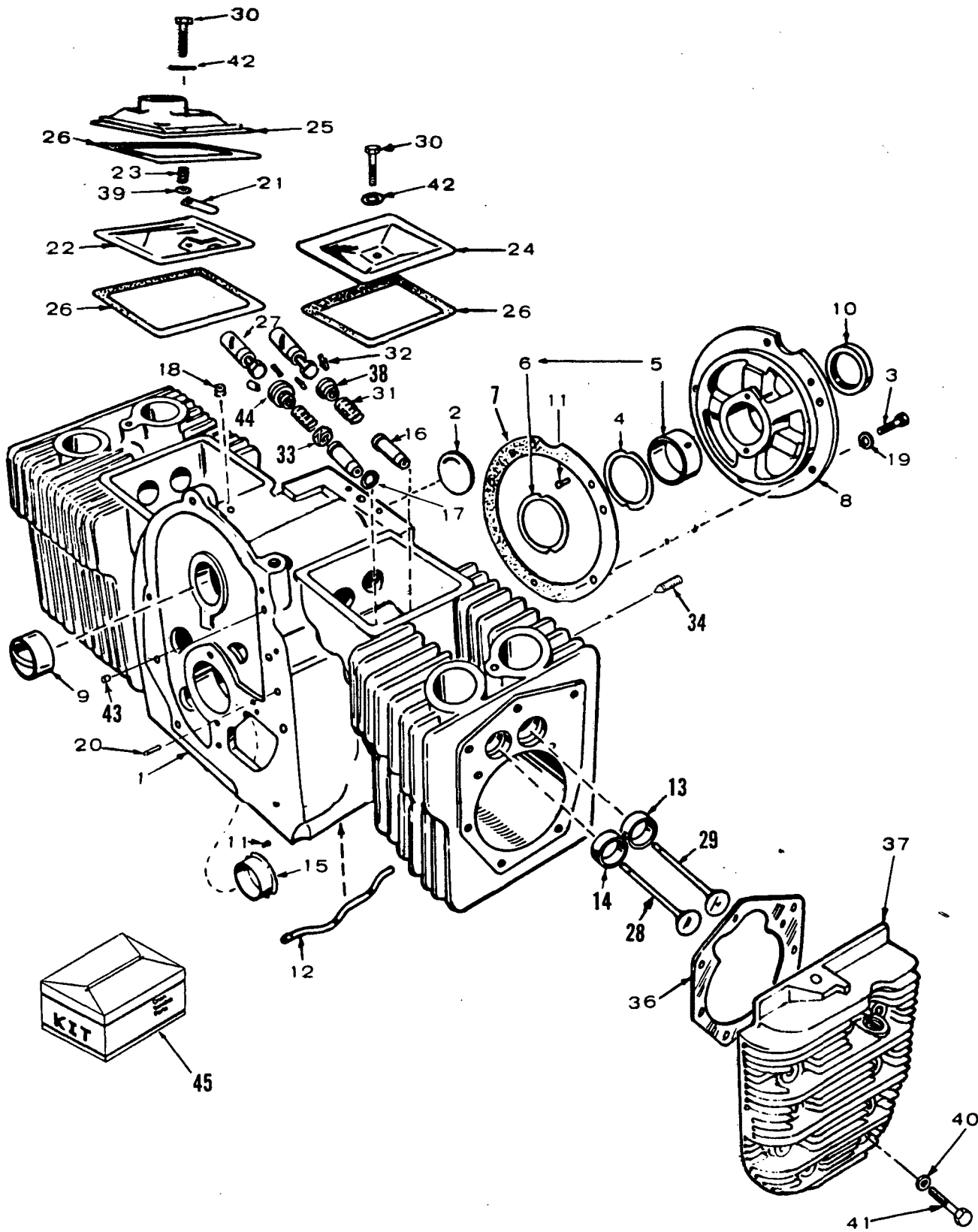

another free manual from www.searctractormanuals.com

Cylinder Block

REF NO.	PART NO.	QTY USED	PART DESCRIPTION	REF NO.	PART NO.	QTY USED	PART DESCRIPTION
1			Block Assembly, Cylinder (All Replacement Cylinder Block Assemblies Use Intake Valve Seals and Include Parts Marked *)	17	110-0068	2	*Gasket Intake Valve Guide Vacuum Port
	110-3148	1	Engines with Standard Rear Bearing Plate	18		1	Tube - Early Models
	110-3151	1	Engines with 4 Boss Bearing Plate		149-1299	1	Plug, Breather Hole - Later Models
	110-3154	1	Engines with SAE A or SAE B Rear Bearing Plate (Does Not Include Rear Bearing Plate)	19	850-0050	5	*Washer, Lock - Spring (3/8")
2	517-0048	1	*Plug, Welch (1-5/8") Camshaft Opening	20	516-0141	2	*Pin, Gear Cover Alignment
3	800-0051	5	*Screw, Cap - Hex Head (3/8-16 x 1-1/4")	21	123-1175	1	Reed, Breather Valve
4	104-0776	AR	*Shim, Crankshaft End Play (.005")	22	123-1173	1	Baffle, Breather Valve
5			Bearing, Crankshaft - Rear (Includes Thrust Washer)	23	123-1174	1	Spring, Breather Valve
	101-0450	1	*Standard	24	110-1879	1	Cover, Valve - RH
	101-0450-02	1	.002" Undersize	25	110-2274	1	Cover, Valve - LH
	101-0450-10	1	.010" Undersize	26	110-1921	3	Gasket, Valve Cover
	101-0450-20	1	.020" Undersize	27		4	Tappet, Valve Standard
	101-0450-30	1	.030" Undersize		115-0006	4	.002" Oversize
6	104-0575	2	*Washer, Thrust		115-0006-02	4	.005" Oversize
7	101-0415	1	*Gasket, Bearing Plate	28	110-2368	2	Valve, Intake
8			Plate, Bearing - Rear	29		2	Valve, Exhaust
	101-0439	1	*Standard		110-1955	2	Standard
	101-0551	1	Optional - 4 Boss		110-2438	2	Stellite
	101-0430	1	Optional - SAE B	30	800-0010	2	Screw, Cap - Hex Head (1/4-20 x 1-3/4")
	101-0437-ol	1	Optional - SAE A	31	110-0539	4	Spring, Valve
9	101-0405	2	*Bearing, Camshaft	32	110-0639	8	Lock, Valve Spring
10	509-0041	1	Seal, Oil - Crankshaft Rear	33	509-0168	2	Seal, Valve - Intake (Optional)
11	516-0072	4	*Pin, Drive - Bearing Stop	34	803-0071	2	Screw, Socket - Set (3/8-16 x 5/8")
12	120-0735	1	*Tube, Oil - Cylinder Block	36		2	Gasket, Cylinder Head Standard
13			Insert, Valve Seat - Exhaust		110-2287	2	Standard
	110-1824	2	*Standard		110-3181	2	Optional (Graphoil)
	110-1824-02	2	.002" Oversize	37		1	Head, Cylinder
	110-1824-05	2	.005" Oversize		110-2564	1	Right Side
	110-1824-10	2	.010" Oversize		110-2563	1	Left Side
	110-1824-25	2	.025" Oversize	38	110-0904	4	Roto Cap - Valve
14			Insert, Valve Seat - Intake	39	526-0018	1	Washer, Flat (1/4" Screw)
	110-0197	2	*Standard	40	526-0122	18	Washer, Flat (5/16" Screw)
	110-0197-02	2	.002" Oversize	41		12	Screw, Cap - Hex Head (Special 5/16-18 x 1-5/8")
	110-0197-05	2	.005" Oversize		800-0540	6	2" Long
	110-0197-10	2	.010" Oversize	42	526-0063	2	Washer, Flat - Copper (1/4" Screw)
	110-0197-25	2	.025" Oversize	43	517-0067	1	Plug, Core Hole <i>exhaust</i>
15			Bearing, Crankshaft - Front Flanged	44	110-0893	2	Washer, Intake Valve Spring Retainer (Optional)
	101-0432	1	*Standard	45		1	Kit, Gasket
	101-0432-02	1	.002" Undersize		168-0140	1	Valve Grind/Carbon Removal (Standard Head Gaskets)
	101-0432-10	1	.010" Undersize		168-0183	1	Valve Grind/Carbon Removal (Graphoil Head Gaskets)
	101-0432-20	1	.020" Undersize		168-0153	1	Gasket Kit, Complete (Standard Head Gaskets)
	101-0432-30	1	.030" Undersize		168-0153	1	Gasket Kit, Complete (Graphoil Head Gaskets)
16			Guide, Valve				
			Engines w/o Intake Valve Seals				
	110-1807	2	Intake				
	110-1807	2	Exhaust				
			Engines with Intake Valve Seals				
	110-1807	2	*Exhaust				
	110-3161	2	*Intake				

* - Parts Included in the Cylinder Block Assembly.

Piston and Rod

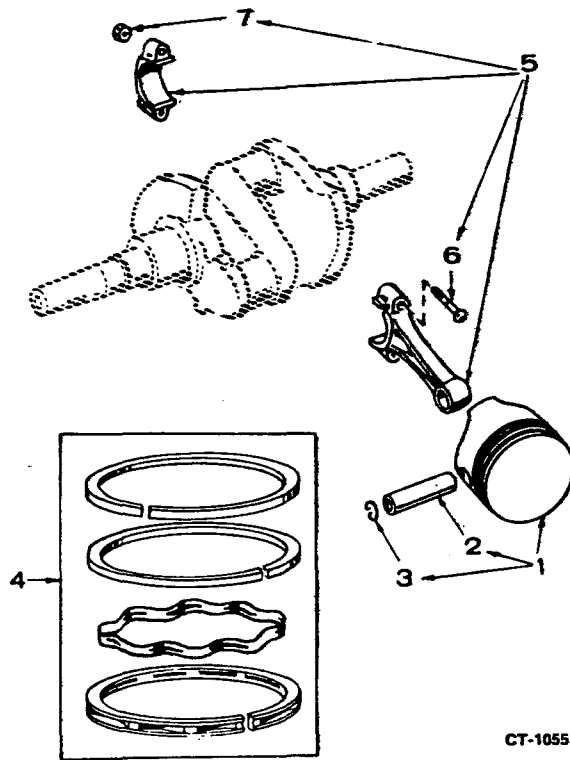

*Piston & Rings Kit
new
112-0264
(Thin)*

CT-1055

REF NO.	PART NO.	QTY USED	PART DESCRIPTION	REF NO.	PART NO.	QTY USED	PART DESCRIPTION
1			Piston and Pin (Includes Retaining Rings)	5			Rod, Connecting (Includes Bolt and Nut)
<i>112-0264</i>	112-0186	2	Standard		114-0257	2	Standard
	112-0186-05	2	.005" Oversize		114-0257-10	2	.010" Undersize
	112-0186-10	2	.010" Oversize		114-0257-20	2	.020" Undersize
	112-0186-20	2	.020" Oversize		114-0257-30	2	.030" Undersize
	112-0186-30	2	.030" Oversize	6	114-0240	4	Bolt, Connecting Rod (Special)
	112-0186-40	2	.040" Oversize	7	870-0302	4	Nut, Hex - Crown Lock (5/16-24)
2	112-0229	2	Pin, Piston				
3	518-0311	4	Ring, Retaining				
4			Ring Set, Piston				
	113-0189	2	Standard				
	113-0189-05	2	.005" Oversize				
	113-0189-10	2	.010" Oversize				
	113-0189-20	2	.020" Oversize				
	113-0189-30	2	.030" Oversize				
	113-0189-40	2	.040" Oversize				

113-0310 Standard (new style) (Thin)

Gear 180

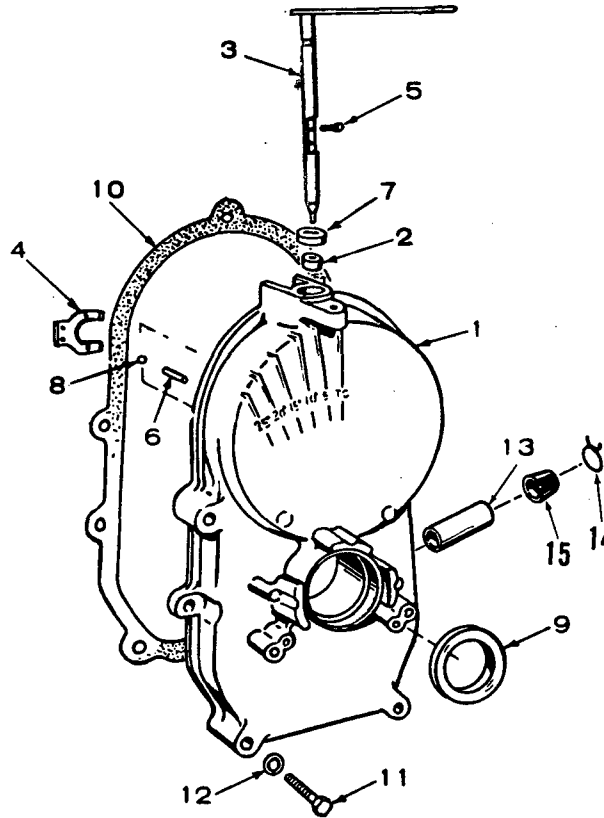

REF NO.	PART NO.	QTY USED	PART DESCRIPTION	REF NO.	PART NO.	QTY USED	PART DESCRIPTION
1	103-0738	1	Gearcase Assembly (Includes Parts Marked *)	9	509-0040	1	*Seal, Oil - Crankshaft
2	510-0105	1	*Bearing, Governor Shaft	10	103-0408	1	Gasket, Gearcase Mounting
3	150-1470	1	*Shaft and Arm, Governor	11	800-0032	4	Screw, Cap - Hex Head 5/16-18 x 1-3/4"
4	150-1187	1	*Yoke, Governor Shaft		800-0545	1	5/16-18 x 2-3/4" (Special)
5	815-0046	2	*Screw, Machine - Pan Head (#8-32 x 3/8")	12	526-0065	5	Washer, Flat - Copper (5/16" Screw)
6	516-0130	1	*Pin, Dowel - Governor Cup Stop	13	149-1299	1	*Tube, Vacuum Port
7	509-0008	1	*Seal, Oil - Governor Shaft	14	503-0301	1	*Clamp, Vacuum Port Cap
8	510-0014	1	*Ball, Bearing - Governor Shaft	15	149-1321	1	*Cap, Vacuum Port

* - Parts Included in 103-0738 Gearcase Assembly.

Camshaft

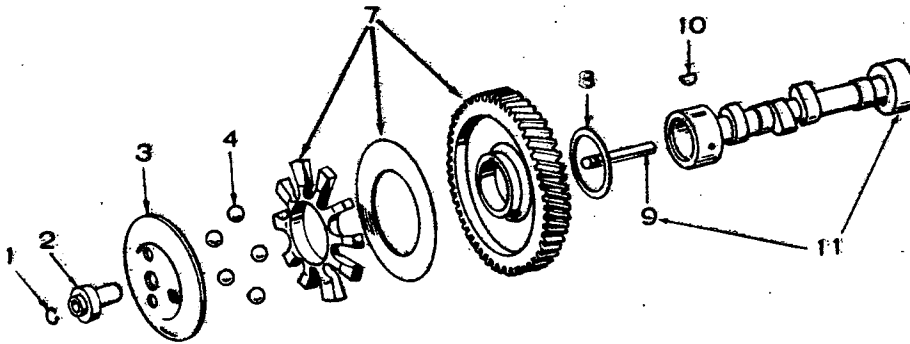

C-1084

REF NO.	PART NO.	QTY USED	PART DESCRIPTION	REF NO.	PART NO.	QTY USED	PART DESCRIPTION
1	150-0078	1	Ring, Retaining	7	105-0332	1	Gear Assembly, Camshaft (Includes Plate and Spacer)
2	150-1519	1	Hub, Governor Cup	8	105-0541	1	Washer, Thrust (Special)
3	150-1520	1	Cup, Governor	9	150-0875	1	Pin, Center
4			Ball, Governor	10	515-0001	1	Key, Woodruff - Camshaft Gear
	510-0015	5	5 Ball Governor	11	105-0402	1	Camshaft (Includes Center Pin)
	510-0015	10	10 Ball Governor				

Crankshaft and Flywheel

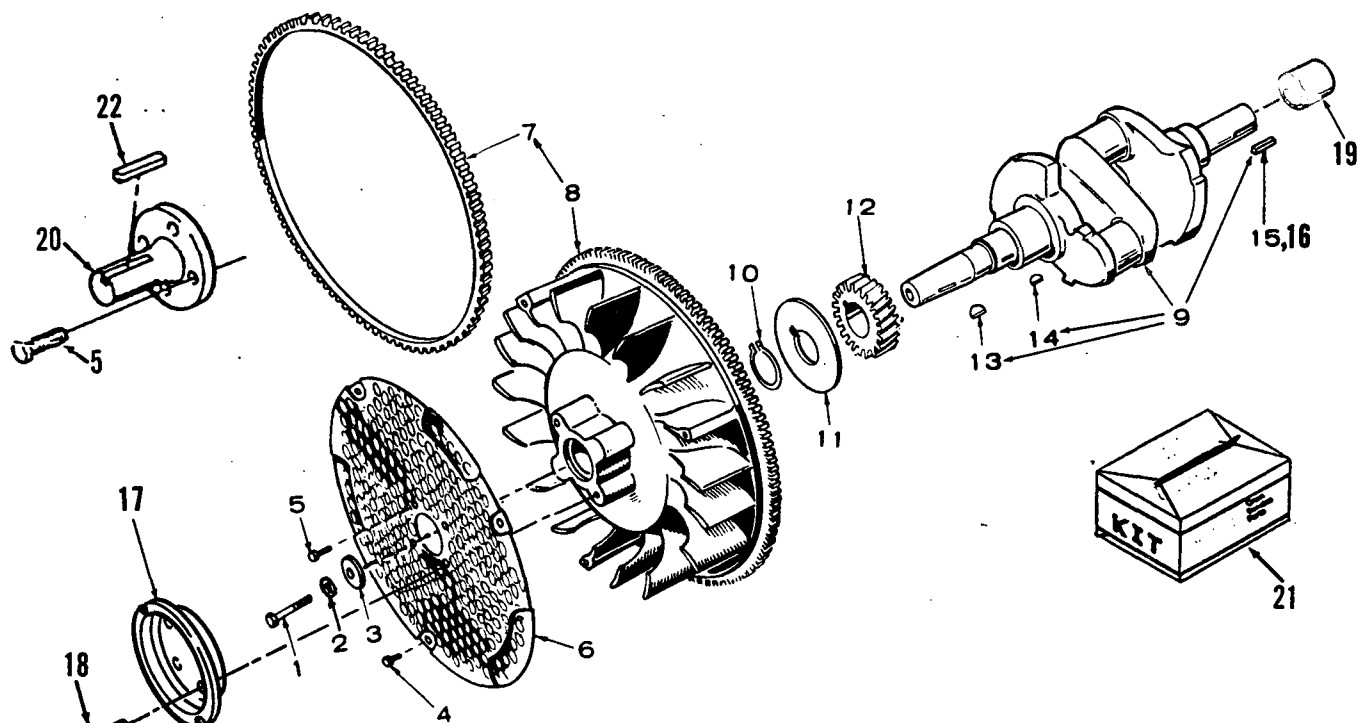

REF NO.	PART NO.	QTY USED	PART DESCRIPTION	REF NO.	PART NO.	QTY USED	PART DESCRIPTION
1	104-0170	1	Screw, Cap - Hex Head (Special)	10	518-0014	1	Ring, Retaining
2	850-0055	1	Washer, Lock - Spring (7/16")	11	104-0043	1	Washer, Gear Retaining (Special)
3	526-0017	1	Washer, Flat (7/16" Screw)	12	104-0032	1	Gear, Crankshaft
4	815-0400	3	Screw, Machine - Truss Head (1/4-20 x 1/2")	13	515-0227	1	*Key, Flywheel
5	821-0014	4	Screw, Cap - Hex Head Locking (5/16-18 x 1/2")	14	515-0001	1	*Key, Crankshaft Gear
6	134-3920	1	Guard, Flywheel	15	515-0103	1	*Key, Crankshaft Stub
7	104-0779	1	Gear, Ring	16	515-0198	1	Key, Crankshaft Stub
8	134-4734	1	Flywheel (Includes Ring Gear With Imbalance Weight - Hi Flo (Identify by 1/2" Drilled Holes on Backside of Flywheel))	17	192-0398	1	Sheave, Rope - Engines with Magneto Ignition
	160-1301	1	Engines with Magneto Ignition - Electric Start - Hi Flo	18	821-0016	4	Screw, Cap - Hex Washer Head (5/16-18" x 3/4")
	160-1307	1	Engines with Magneto Ignition - Recoil Start - Hi Flo	19	190-0267	1	Bearing, Sleeve - Units use Clutch Housing
	104-0614	1	Clutch, Flywheel	20	190-0546	1	PTO Shaft - (2" Pilot) 1-7/16" Diameter
9			Crankshaft (Includes Parts Marked *)		190-0687	1	1" Diameter
	104-1351	1	1.125" Dia. Stub	21			Kit, Shaft
	104-1353	1	1-7/16" Dia. Stub		190-0577	1	Front PTO, 1-7/16" Diameter
	104-1352	1	Use with Clutch Flywheel		541-0222	1	PTO, 1" Diameter
	104-1359	1	1.530" Dia. Stub	22	515-0007	1	Key, Machine (1/4 x 2")
	104-1349	1	9 Tooth Spline				
	104-1028	1	1.626" Dia. Stub - Tapered (No Keys)				
	104-1348	1	1.125" Dia. Stub - Tapered				

* - Parts Included in Crankshaft Kit.

Governor

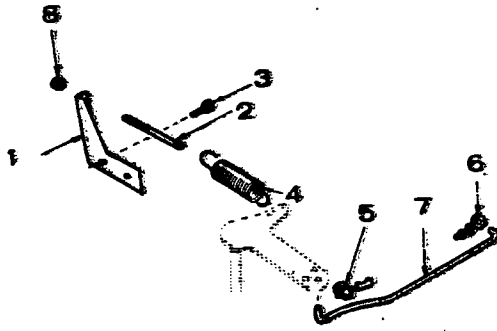

REF NO.	PART NO.	QTY USED	PART DESCRIPTION	REF NO.	PART NO.	QTY USED	PART DESCRIPTION
1	150-1433	1	Bracket, Governor Control	5	870-0278	1	Clip, Retaining - Control Rod
2	150-0694	1	Stud, Adjusting	6	518-0004	1	Clip, Retaining - Control Rod
3	821-0010	2	Screw, Cap Hex Head Locking (1/4-20 x 1/2")	7	150-1350	1	Rod, Control
4	150-1214	1	Spring, Governor	8	870-0131	1	Nut, Governor Adjusting

Air Housing

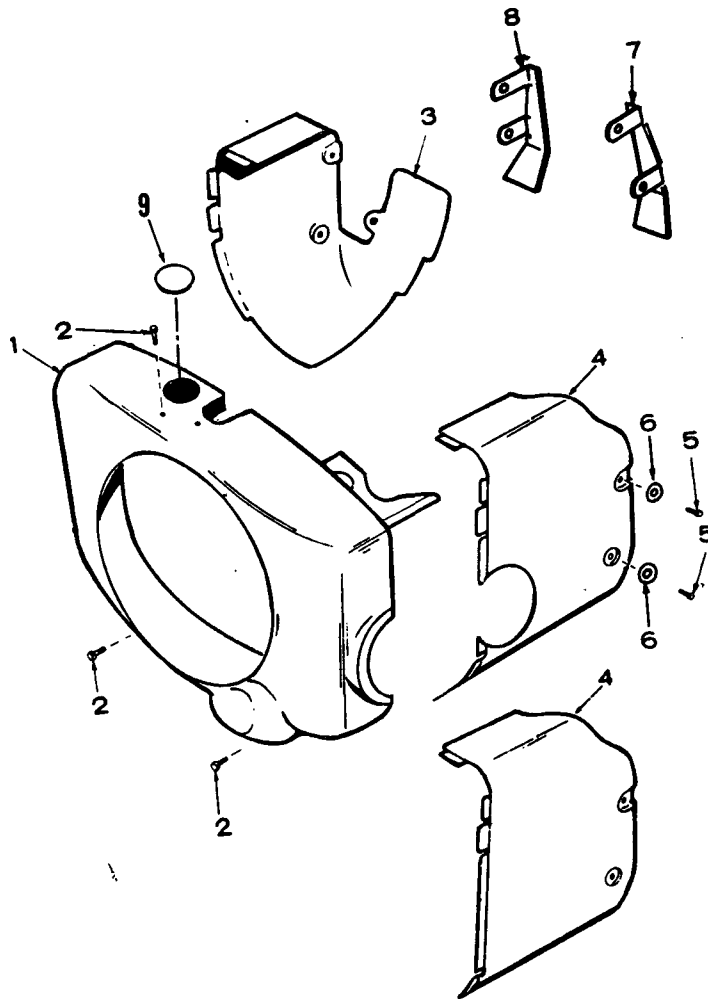

M-1463

REF NO.	PART NO.	QTY USED	PART DESCRIPTION	REF NO.	PART NO.	QTY USED	PART DESCRIPTION
1	134-3749	1	Housing, Blower Sets Without Oil Filter	5	815-0290	4	Screw, Cap - Hex Head (1/4-20 x 5/8")
	134-4400	1	Sets With Oil Filter	6	526-0021	4	Washer, Flat (1/4" Screw)
2	815-0261	3	Screw, Cap - Hex Head (1/4-20 x 7/16")	7	134-3582	1	Baffle, Cylinder Head - Right Side
3	134-4371	1	Housing, Cylinder Air - Left Side	8	134-3583	1	Baffle, Cylinder Head - Left Side
4			Housing, Cylinder Air (Right Side)	9	517-0129	1	Plug, Hole (Optional)
	134-3400	1	Use Sets without Oil Filter - Free Flo				
	134-3518	1	Use Sets with Oil Filter - Free Flo				

Oil System

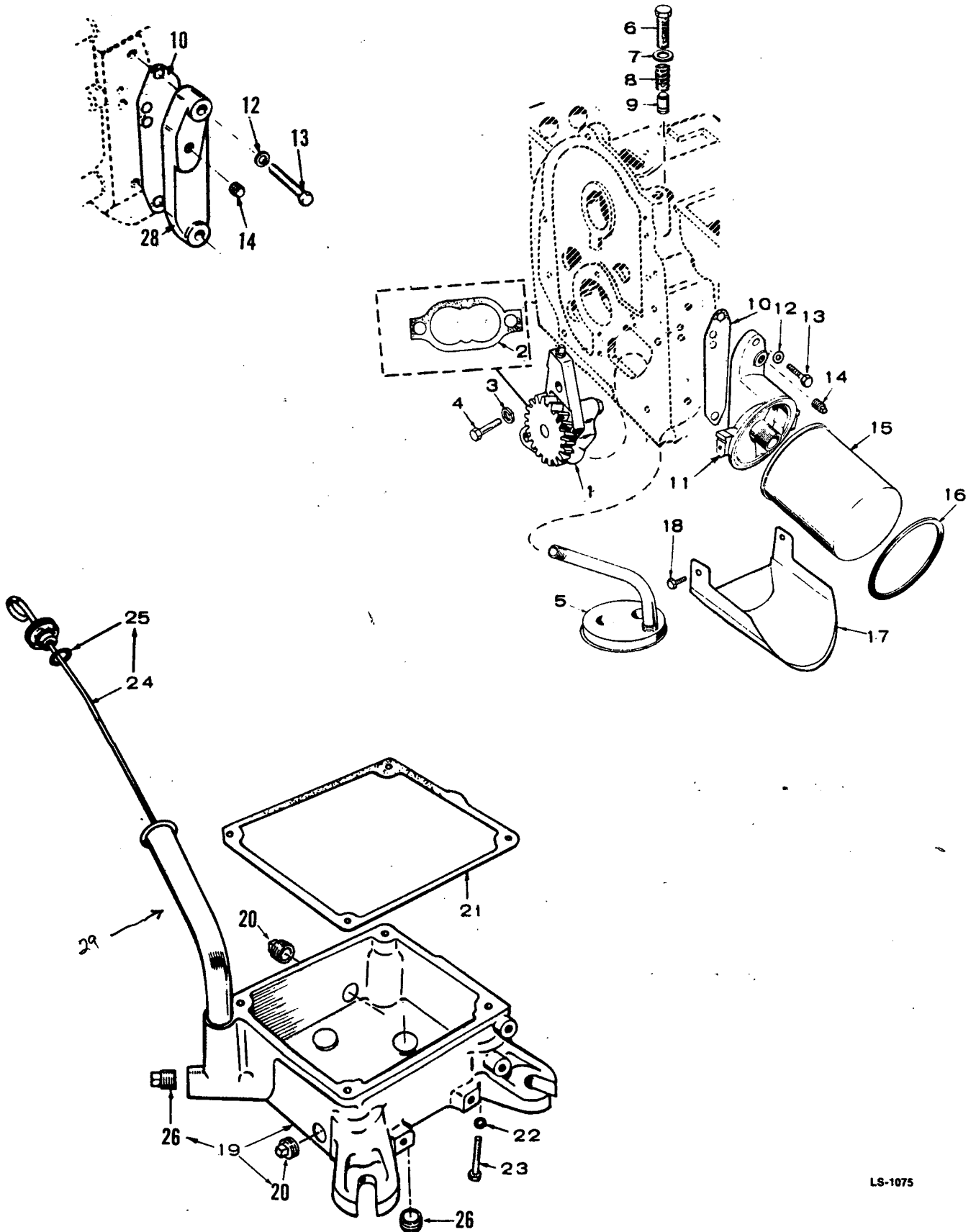

Oil System

REF NO.	PART NO.	QTY USED	PART DESCRIPTION	REF NO.	PART NO.	QTY USED	PART DESCRIPTION
1	120-0491	1	Pump, Oil (Components Not Sold Separately)	13	800-0028	2	Screw, Cap - Hex Head (5/16-18 x 1")
2	120-0161	1	Gasket Kit, Oil Pump	14	505-0057	1	Plug, Pipe
3	850-0040	2	Washer, Lock Spring (1/4")	15	122-0645	1	Filter, Oil
4	800-0007	2	Screw, Cap - Hex Head (1/4-20 x 1")	16	122-0347	1	Seal, Air-Filter to Housing
5	120-0713	1	Cup, Intake - Oil Pump	17	122-0360	1	Drain, Oil Filter
6	801-0050	1	Screw, Cap - Hex Head (3/8-24 x 1")	18	815-0194	2	Screw, Cap - Hex Head w/ET (#10-32 x 3/8")
7	526-0066	1	Washer, Flat - Copper (3/8" Screw)	19	102-0850	1	Base, Oil
8	120-0140	1	Spring, Bypass Valve	20	505-0056	2	Plug, Pipe (1/2") Square Head - Oil Drain
9	120-0398	1	Plunger, Bypass Valve	21	102-1200	1	Gasket, Oil Base
10	122-0321	1	Gasket, Oil Filter Adapter Use with Adapter 122-0320	22	850-0050	4	Washer, Lock - Spring (3/8")
	122-0375	1	Use with Cover 122-0438	23	800-0056	4	Screw, Cap - Hex Head (3/8-16 x 2-1/2")
11	122-0320	1	Adapter, Oil Filter	24	123-1292	1	Cap and Indicator, Oil Fill
12	526-0065	2	Washer, Flat - Copper (5/16" Screw)	25	509-0142	1	Gasket, Oil Fill Cap ("O" Ring)
				26	505-0937	2	Plug, Socket Head (3/8")
				28	122-0438	1	Cover, Oil Filter Pad - Optional
				2A	123-1191	1	oil Fill Tube

Fuel System

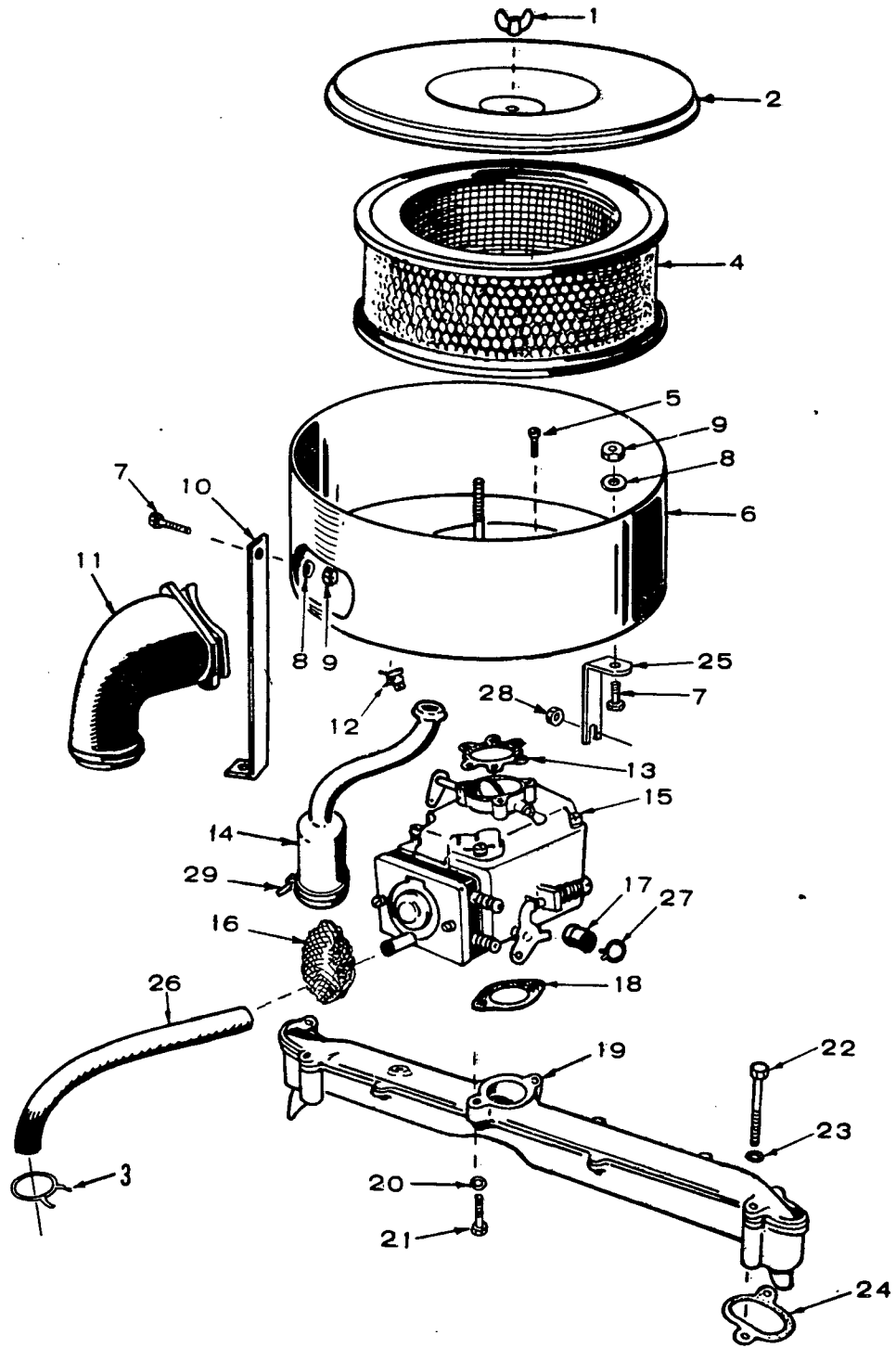

Fuel System

REF NO.	PART NO.	QTY USED	PART DESCRIPTION	REF NO.	PART NO.	QTY USED	PART DESCRIPTION
1	865-0020	1	Nut, Wing (1/4-20)	16	123-1417	1	Filter, Breather Tube
2	140-1168	1	Cover, Air Cleaner	17	149-1321	1	Cap, Fuel Outlet
3	503-0731	2	Clamp, Hose (1/2")	18	145-0438	1	*Gasket, Carburetor Mounting
4	140-1216	1	Filter, Air (Paper)	19	154-2666	1	Manifold, Intake
5	815-0463	3	Screw, Machine - Slotted Head (#10-32 x 3/8")	20	850-0040	2	Washer, Lock - Spring (1/4")
6	140-1213	1	Housing, Air Cleaner	21	800-0023	2	Screw, Cap - Hex Head (1/4-20 x 1-3/8")
7	800-0003	2	Screw, Cap - Hex Head (1/4-20 x 1/2")	22	800-0033	4	Screw, Cap - Hex Head (5/16-18 x 2")
8	853-0013	3	Washer, Lock - ET (1/4")	23	850-0045	4	Washer, Lock - Spring (5/16")
9	862-0001	2	Nut, Hex (1/4-20)	24	154-1744	2	Gasket, Manifold to Block
10	140-1198	1	Support, Air Cleaner (4.4" Lg)	25	140-1313	1	Support, Air Cleaner - Front (2.37" Lg)
11	140-1549	1	Tube, Air Intake	26	503-0707	1	Hose, Fuel
12	518-0328	2	Clip, Cable	27	503-0301	1	*Clamp, Hose
13	140-1215	1	*Gasket, Air Cleaner to Carburetor	28	870-0257	1	Nut, Hex - Self-lock (5/16-18)
14	123-1277	1	Tube, Crankcase Breather	29	332-0941	1	Tie, Breather Tube
15	142-0660	1	Carburetor Assembly (See Separate Page for Components) (Includes Parts Marked *)				

* - Parts Included in 142-0660 Carburetor Kit Assembly.

Carburetor (With Integral Jet Pump) Components
(142-0600)

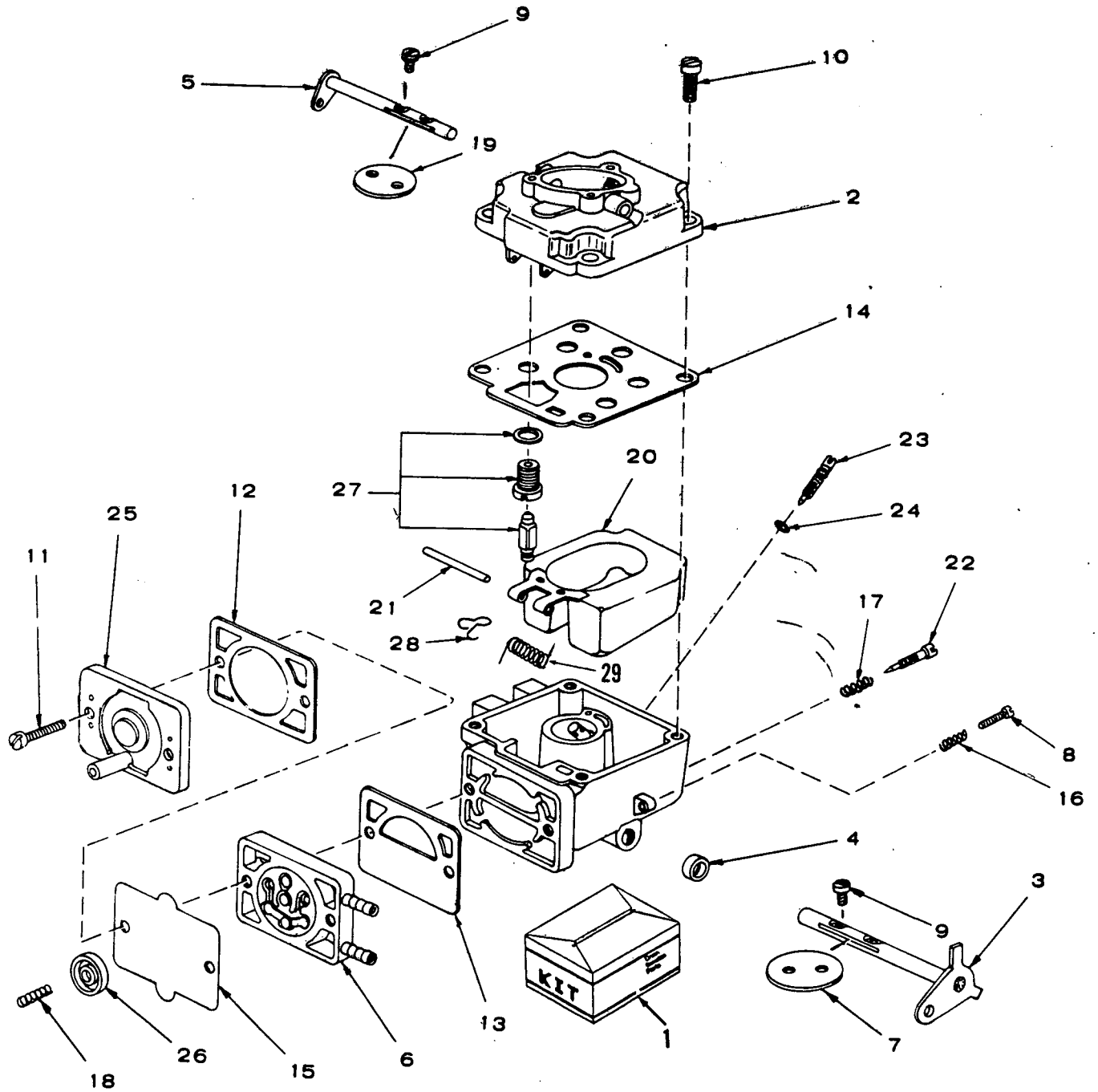

Carburetor (With Integral Fuel Pump) Components (142-0660)

REF NO.	PART NO.	QTY USED	PART DESCRIPTION	REF NO.	PART NO.	QTY USED	PART DESCRIPTION
	142-0660	1	Carburetor, Complete (With Integral Fuel Pump)	12	142-0541	1	†Gasket, Pump Cover
	142-0571	1	*Gasket Set (Includes Parts Marked †)	13	142-0542	1	†Gasket, Inlet Plate
- /	142-0570	1	Repair Kit (Includes Parts Marked *)	14	142-0572	1	†Gasket, Carburetor Body
		1	Body, Lower - Not Sold Separately	15	142-0555	1	†Diaphragm, Fuel Pump
2		1	Body, Upper - Not Sold Separately	16	142-0544	1	Spring, Throttle Stop
3	142-0534	1	*Shaft, Throttle	17	142-0282	1	*Spring, Idle Needle
4	142-0535	1	†"O" Ring, Throttle Shaft Seal	18	142-0545	1	*Spring, Fuel Pump
5	142-0536	1	Shaft, Choke	19	142-0546	1	Fly, Choke
6	142-0537	1	*Valve Assembly, Reed Fuel Pump	20	146-0380	1	Float Assembly (Includes Assist Spring)
7	142-0538	1	Fly, Throttle	21	142-0548	1	*Shaft, Float
8	142-0064	1	Screw, Throttle Stop	22	142-0016	1	*Needle, Idle
- 9	142-0334	4	*Screw, Fly to Shaft	23	142-0549	1	Needle, Power
10	142-0539	4	*Screw, Upper to Lower Body	24	142-0550	1	†"O" Ring, Seal - Power Needle
- 11	142-0540	2	Screw, Pump Cover to Body	25	142-0551	1	Cover, Pump
				- 26	142-0552	1	*Plate, Drive - Fuel Pump
				27	142-0553	1	*Valve, Assembly, Float
				28	142-0554	1	Clip, Retaining - Float Valve
				29	146-0379	1	Spring, Float Assist

† - Parts Included in 142-0571 Gasket Set.

* - Parts Included in 142-0570 Repair Kit.

Ignition

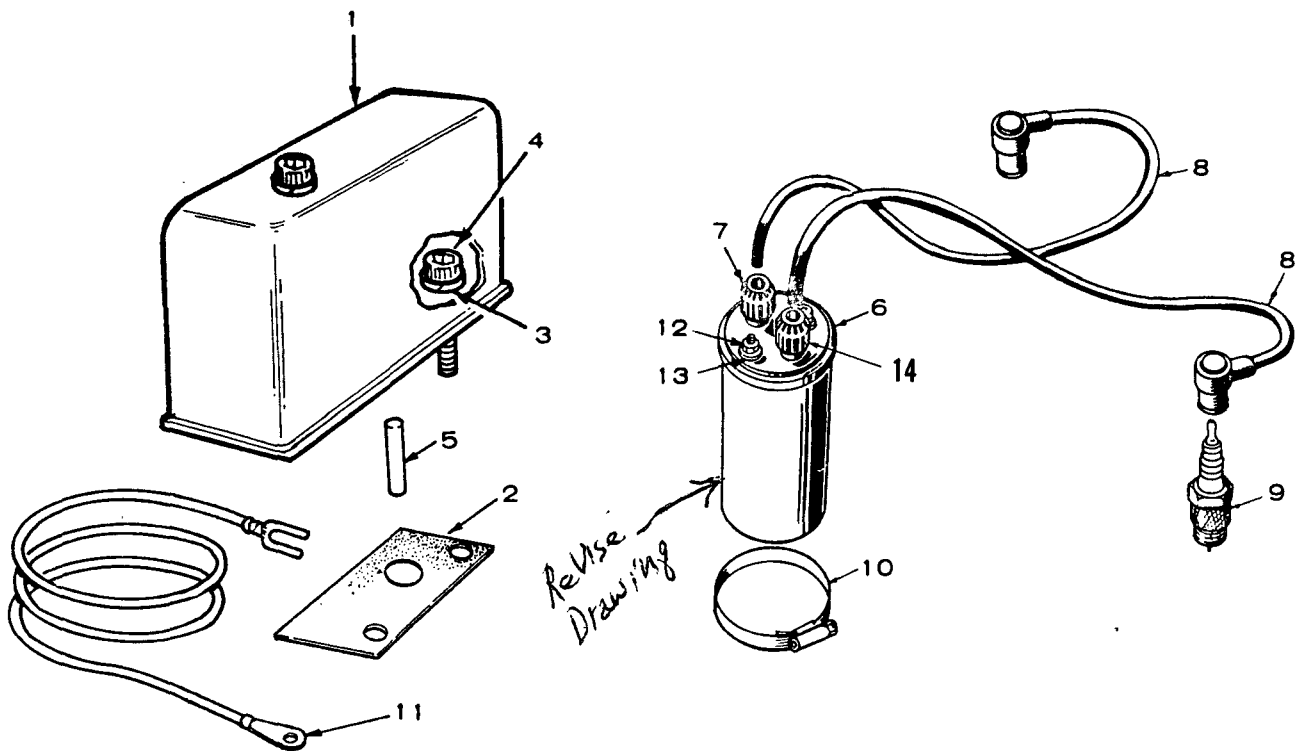

REF NO.	PART NO.	QTY USED	PART DESCRIPTION
1	160-1303	1	Box Assembly, Breaker (See Separate Page for Components) (Includes Mounting Gasket)
2	160-1150	1	Gasket, Breaker Box Mounting
3	850-0038	2	Washer, Lock - Spring (1/4")
4	802-0034	2	Screw, Socket Head (1/4-20 x 3/4")
5	160-1151	1	Plunger, Breaker Points
6	166-0772	1	Coil, Ignition
7	166-0604	2	Cap, Coil Terminal (Part of Coil)

REF NO.	PART NO.	QTY USED	PART DESCRIPTION
8	167-1602	2	Cable, Spark Plug
9	167-0298	2	Plug, Spark
10	503-0311	1	Clamp, Coil
11	336-2378	1	Lead, Breaker Box to Coil
12	166-0554	2	Nut, Hex (Special)
13	850-2005	2	Washer, Lock - Spring (Metric)
14	166-0614	2	Bushing, Rubber (Inside of Cap 166-0604)

160-1376

1 Kit, Electronic
(converts Breaker
Ignition to Electronic)

PSB #556 (1/2)

Breaker Box

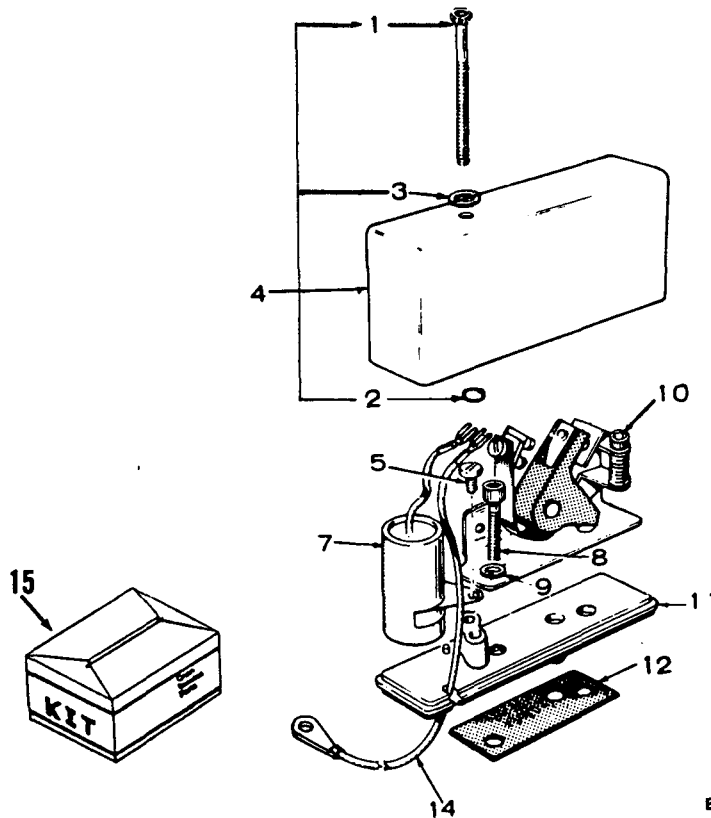

ES-1217

REF NO.	PART NO.	QTY USED	PART DESCRIPTION	REF NO.	PART NO.	QTY USED	PART DESCRIPTION
	160-1303	1	Box, Breaker (Includes Parts Marked *)	8	802-0034	2	*Screw, Cap - Socket Head (1/4-20 x 3/4")
1	802-0022	1	*Screw, Cap - Hex Socket (#10-24 x 1-1/2")	9	850-0040	2	*Washer, Lock (1/4")
2	509-0065	1	*Retainer ("O" Ring)	10	160-1183	1	*Point Set, Breaker
3	526-0008	1	*Washer, Flat (#10 Screw)	11	160-1219	1	*Base, Breaker
4	160-1285	1	*Cover, Breaker Box	12	160-1150	1	*Gasket, Breaker Box
5	815-0358	1	*Screw, Cap - Slotted (#8-32 x 5/16")	14	336-2378	1	Lead, Breaker Box to Coil
7	312-0246	1	*Condenser	15	160-1211	1	Tune Up Kit (Includes Point and Condenser)

* - Parts Included in 160-1303 Breaker Box.

Starter Motor Components (191-0933)

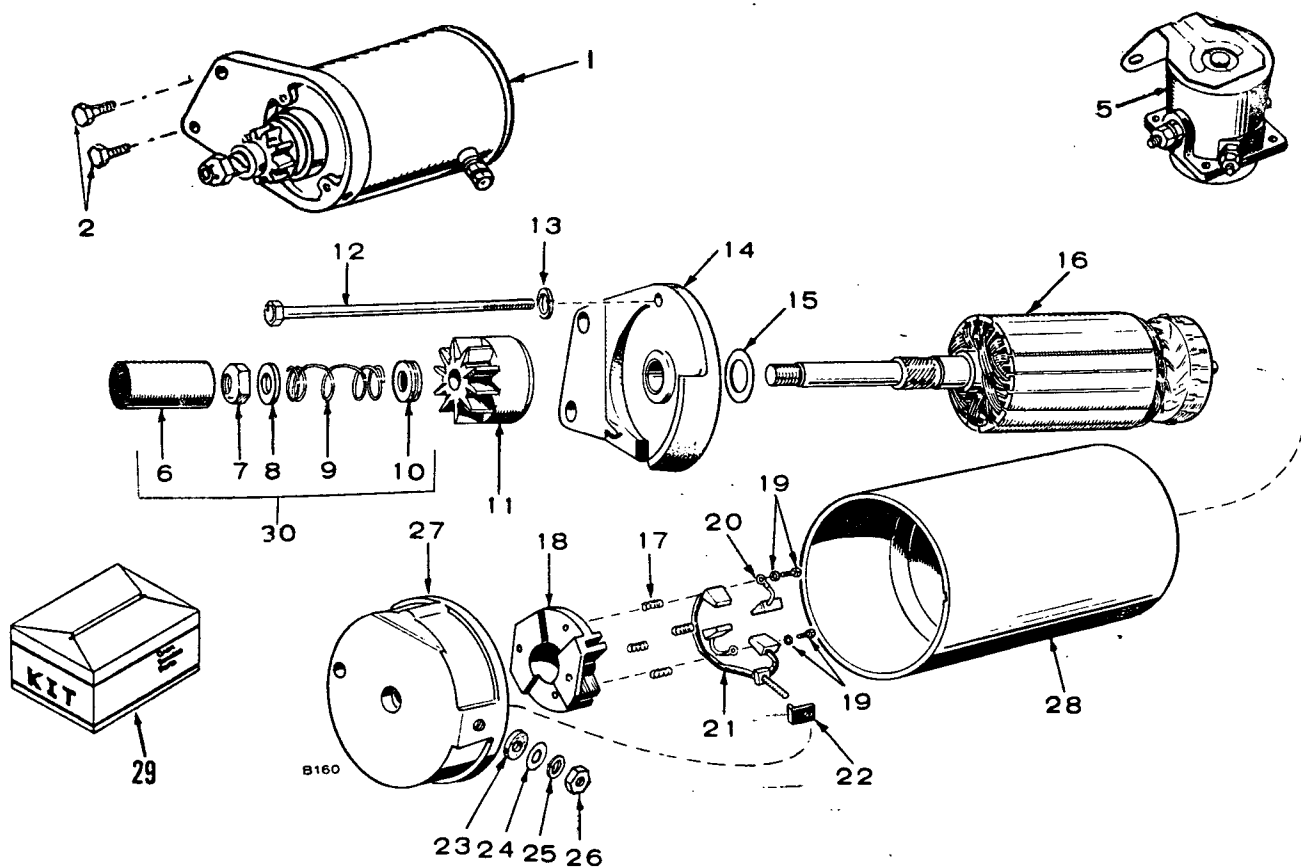

REF NO.	PART NO.	QTY USED	PART DESCRIPTION	REF NO.	PART NO.	QTY USED	PART DESCRIPTION
1	191-0933	1	Motor, Starter (Complete)	19	§	2	†Screw and Lock Washer
2	815-0570	2	Screw, Cap - Hex Washer Head (5/16-18 x 1")	20	§	2	†*Brush, Ground
5	307-1031	1	Relay, Start Solenoid	21	§	1	†*Stud and Brush Assembly, Input
6	§	1	#Cover, Dust	22	§	1	†Bushing, Insulation - Input Stud
7	§	1	#Nut, Stop	23	§	1	†Washer, Insulation - Input Stud
8	§	1	#Washer, Stop Nut	24	§	1	†Washer, Flat - Input Stud
9	§	1	#Spring, Anti-Drift	25	§	1	†Washer, Lock - Input Stud
10	§	1	#Spacer, Dust Cover	26	§	1	†Nut, Securing - Input Stud
11	191-1036	1	Drive Assembly	27	191-1040	1	Cap Assembly, Commutator (Includes Parts Marked †)
12	191-1048	2	Screw, Cap - Hex Head	28	§	1	Housing, Starter Motor
13	850-0040	2	Washer, Lock - Spring (1/4")	29	191-1041	1	Repair Kit, Brush, Spring and Stud (Includes Parts Marked *)
14	191-1037	1	Cap Assembly, Drive End	30	191-1359	1	Dust Cover Assembly (Includes Parts Marked #)
15	191-1038	1	Washer, Armature Thrust				
16	191-1039	1	Armature				
17	§	4	†*Spring, Brush				
18	§	1	†Brush Holder				

† - Parts Included in 191-1040 Cap Assembly.
 * - Parts Included in 191-1041 Brush, Spring, and Stud Kit.
 # - Included in the 191-1359 Dust Cover Assembly.
 § - Not Sold Separately.

OPTIONAL EQUIPMENT SECTION

This section contains illustrated parts listing of factory installed options for these industrial engines. Options may not be applicable to all models; for field conversions additional parts are usually required. Optional parts listed in this section are in addition or in place of those shown in the standard engine parts section.

Option 1
Flywheel Alternator - 20 Ampere (Phelon)

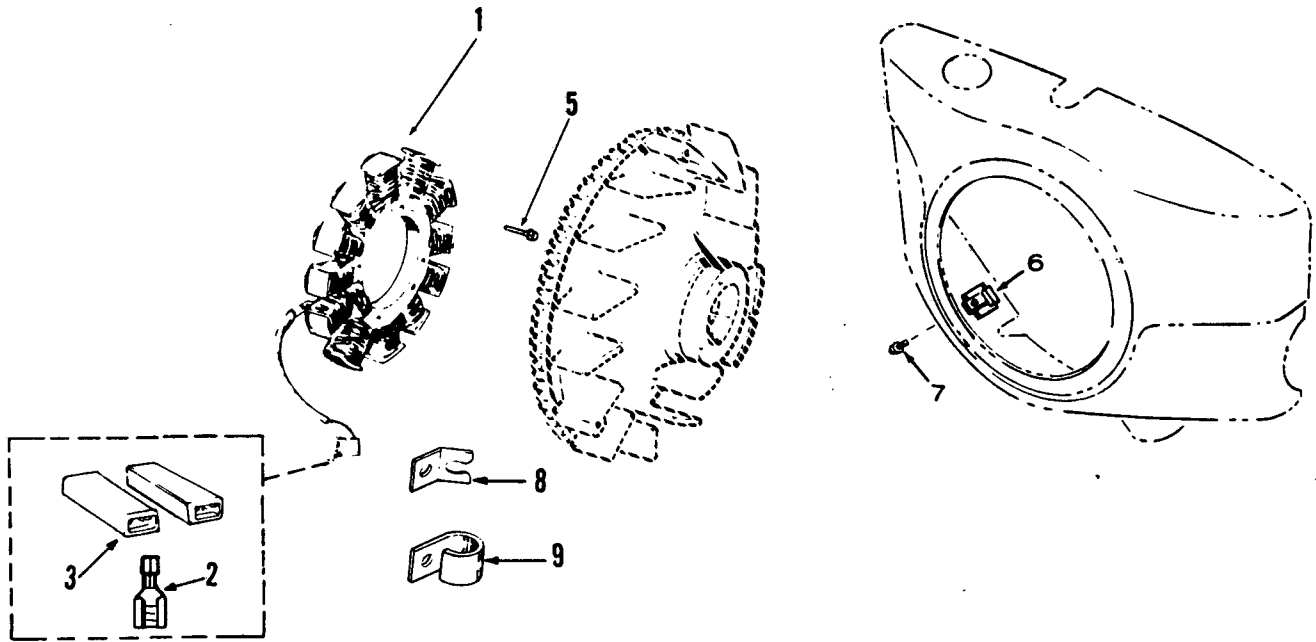

REF NO.	PART NO.	QTY USED	PART DESCRIPTION
1	191-1276	1	Stator (Includes Terminals and Connector Bodies)
2	332-2423	2	*Terminal, Stator Leads
3	323-1257	2	Kit, Body Terminal Connector (Includes Parts Marked *)
5	815-0470	3	Screw, Machine - Hex Head - Self Lock (#10-32 x 1-1/2")

REF NO.	PART NO.	QTY USED	PART DESCRIPTION
6	191-1748 S/S 191-2221	1	Regulator, Voltage
7	821-0007	1	Screw, Cap - Hex Washer Head (1/4-20 x 1/4")
8	167-0188	1	Clip, Cable
9	332-2319	1	Clamp, Wire - Alternator Leads

* - Parts Included in 323-1257 Alternator Connector Body Kit.

Opti 1 2
 Flywheel Alternator - 15 Ampere (Phelon)

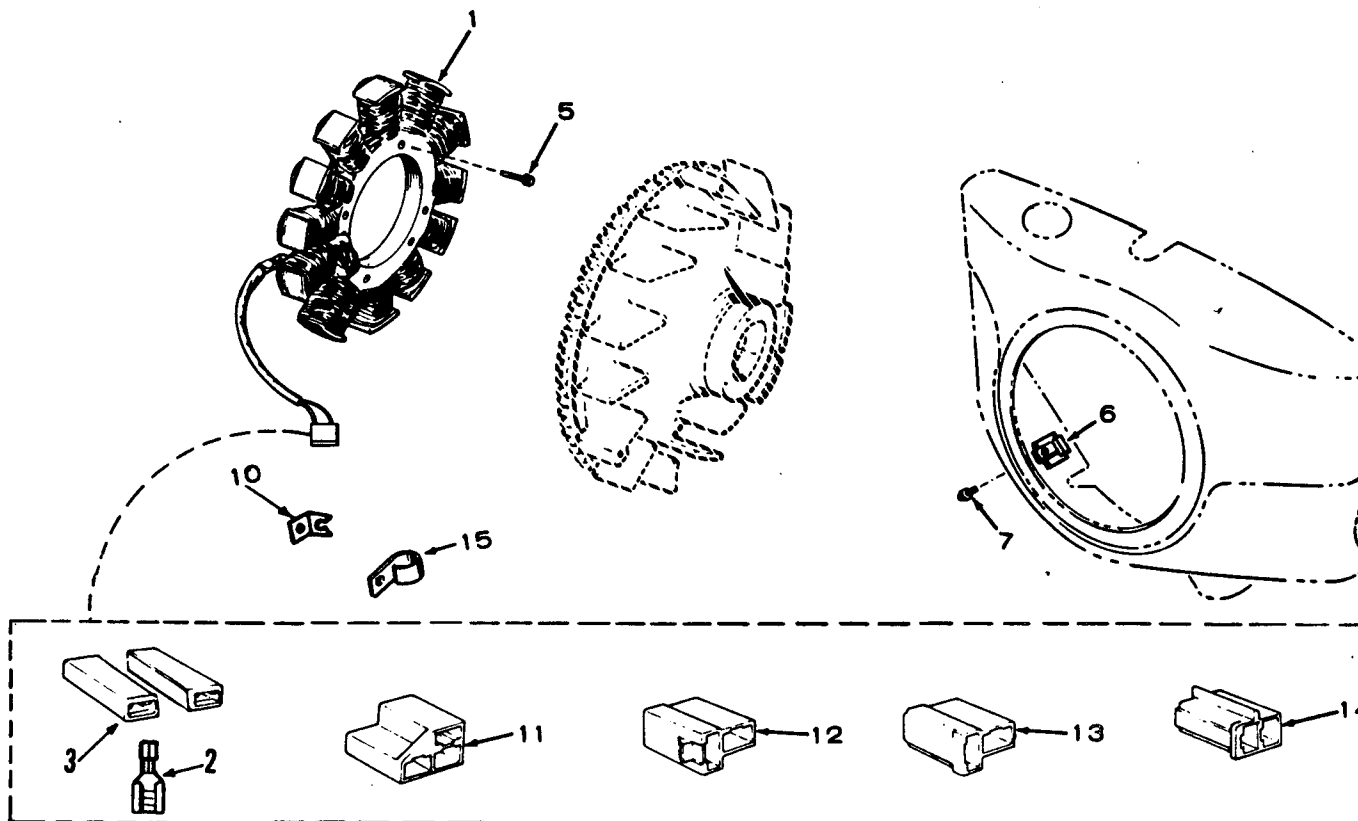

REF NO.	PART NO.	QTY USED	PART DESCRIPTION	REF NO.	PART NO.	QTY USED	PART DESCRIPTION
1	191-1256	1	Stator (Includes Terminals and Connector Bodies)	10	167-0188	1	Clip, Cable
2	332-2423	3	+Terminal Stator Leads	11	323-0853	1	Body, Terminal Connector
3	323-1257	2	Kit, Body Terminal Connector (Includes Parts Marked +)	12	323-1085	1	Body, Terminal Connector
5	815-0593	3	Screw, Machine - Hex Head - Self-Lock (#10-32 x 1-3/8")	13	323-0892	1	Body, Terminal Connector
5 ⁰⁵	191-2227			14	323-0890	1	Body, Terminal Connector
6	191-1206	1	Regulator, Voltage	15	332-2319	1	Clamp, Wire - Alternator Leads
7	821-0007	1	Screw, Cap - Hex Washer Head (1/4-20 x 1/4")				

+ - Parts Included in 323-1257 Alternator Terminal Connector Body Kit.

another free manual from www.searstractormanuals.com

**Option 3
Governor Control - Variable Speed
(Front Pull)**

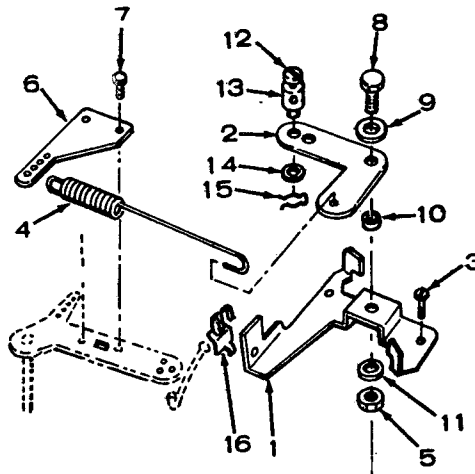

REF NO.	PART NO.	QTY USED	PART DESCRIPTION	REF NO.	PART NO.	QTY USED	PART DESCRIPTION
1	150-1368	1	Bracket, Governor Control	9	526-0021	1	Washer, Flat (1/4" Screw)
2	150-1366	1	Link, Governor Control	10	150-1269	1	Bushing, Governor Control
3	815-0439	3	Screw, Cap - Hex Head Locking (#8 x 1/2")	11	850-0040	1	Washer, Lock - Spring (1/4")
4	150-1369	1	Spring, Governor	12	815-0104	1	Screw, Machine - Fillister Head (#8-32 x 5/16")
5	862-0001	1	Nut, Hex (1/4-20)	13	152-0155	1	Swivel, Cable - Throttle
6	150-1367	1	Adapter, Governor Arm	14	526-0006	1	Washer, Flat (15/64" ID x 1/2" OD x 3/64" Thk)
7	815-0181	2	Screw, Cap - Hex Head w/ET (#10-32 x 1/2")	15	516-0059	1	Pin, Cotter
8	800-0004	1	Screw, Cap - Hex Head (1/4-20 x 5/8")	16	518-0176	1	Clip, Cable - Throttle

Option 4
Governor Control Variable Speed
(Side Pull)

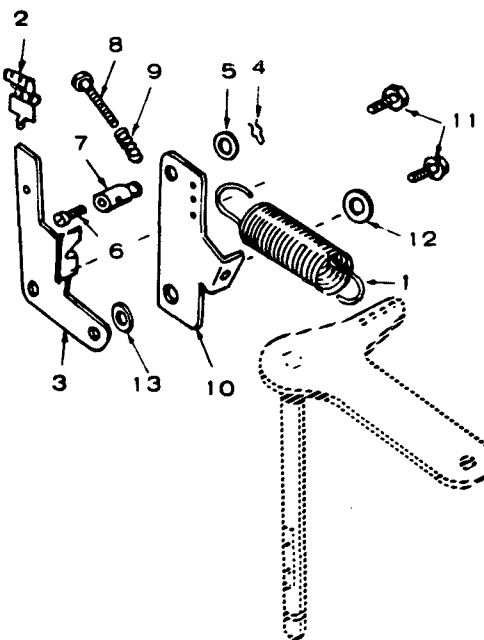

REF NO.	PART NO.	QTY USED	PART DESCRIPTION	REF NO.	PART NO.	QTY USED	PART DESCRIPTION
1	150-1214	1	Spring, Governor	9	150-1398	1	Spring, Idle Setting
2	518-0176	1	Clip, Cable	10	150-1345	1	Arm, Governor Control
3	150-1725	1	Bracket, Cable		150-1576	1	Use With Swivel
4	516-0059	1	Pin, Cotter	11	815-0436	2	Screw, Self-Locking - Hex Washer Head (1/4-20 x 1/2")
5	526-0006	1	Washer, Flat (#12 Screw)	12	526-0021	2	Washer, Flat (1/4" Screw)
6	815-0104	1	Screw, Machine - Fillister Head (#8-32 x 5/16")	13	150-1269	1	Bushing, Control Arm
7	152-0155	1	Swivel, Cable Holding				
8	815-0475	1	Screw, Machine - Hex Washer Head (#6-32 x 7/8")				

**Option 5
Fuel System
(Carburetor W/O Integral Fuel Pump)**

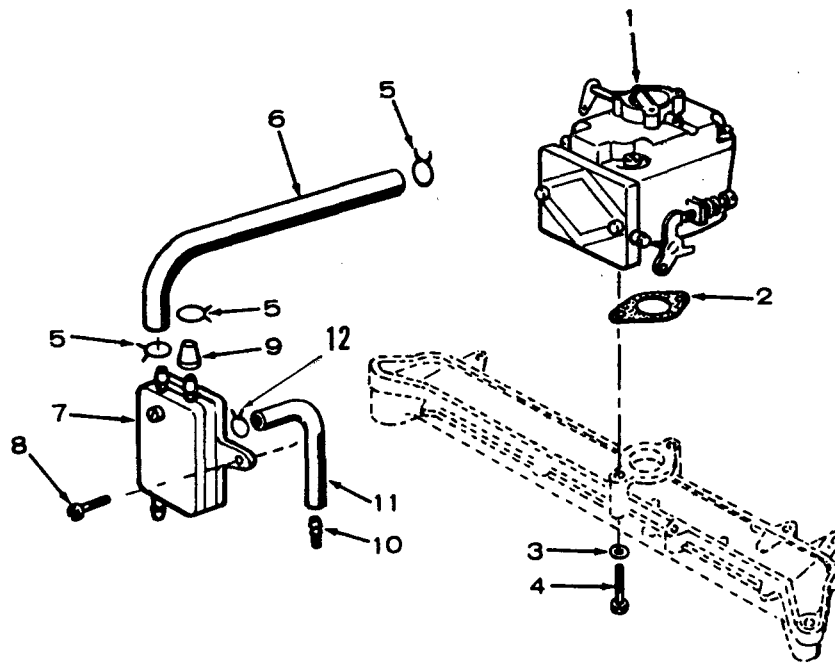

REF NO.	PART NO.	QTY USED	PART DESCRIPTION	REF NO.	PART NO.	QTY USED	PART DESCRIPTION
1	142-0661	1	Carburetor Assembly - Gasoline (See Separate Page for Components) (Includes Parts Marked +)	7	149-1982	1	Pump, Fuel (See Separate Page for Components) (Includes Parts Marked *)
2	145-0438	1	+Gasket, Carburetor Mounting	8	815-0555	2	Screw, Tapping - Pan Head (10-24 x 5/8")
3	850-0040	2	Washer, Lock - Spring (1/4")	9	149-1321	1	+*Cap, Fuel Outlet
4	800-0023	2	Screw, Cap - Hex Head (1/4-20 x 1-3/8")	10	149-1299	1	Tube, Vacuum Port
5	503-0301	3	+*Clamp, Hose (7/16")	11	503-0707	1	Line, Impulse
6	503-0664	1	Hose, Fuel (1/4" ID x 11" Lg)	12	503-0731	1	Clamp, Wire (1/2")

* - Parts Included in 149-1982 Fuel Pump Kit.
+ - Parts Included in 142-0661 Carburetor Assembly Kit.

**Option 5
Carburetor Components
(Without Integral Fuel Pump)
(142-0661)**

REF NO.	PART NO.	QTY USED	PART DESCRIPTION	REF NO.	PART NO.	QTY USED	PART DESCRIPTION
	142-0661	1	Carburetor, Gasoline (Includes Mounting Gasket)	12	142-0559	1	*Gasket, Inlet Plate
	142-0591	1	Gasket Kit (Includes Parts Marked *)	13	142-0553	1	†Valve Assembly, Float
1		1	Body, Lower (Not Sold Separately)	14	142-0572	1	*Gasket, Carburetor Body
2		1	Body, Upper (Not Sold Separately)	15	149-1983	1	Plate, Inlet (Includes Cap and Clamp)
3	142-0534	1	†Shaft, Throttle	16	142-0544	1	Spring, Throttle Stop
4	142-0535	1	*O-Ring, Packing - Throttle Shaft	17	142-0282	1	†Spring, Idle Needle
5	142-0536	1	Shaft, Choke	18	142-0550	1	*O-Ring, Packing - Power Need
6	142-0554	1	Clip, Retaining - Float Valve	19	142-0546	1	Fly, Choke
7	142-0538	1	Fly, Throttle	20	146-0380	1	Float Assembly (Includes Assist Spring)
8	142-0064	1	Screw, Throttle Stop	21	142-0548	1	†Shaft, Float
9	142-0334	4	†Screw, Fly to Shaft	22	142-0016	1	†Needle, Idle
10	142-0539	4	Screw, Upper to Lower Body	23	142-0549	1	Needle Assembly, Power
11	142-0539	2	Screw, Inlet Plate	24	142-0523	1	*Gasket, Float Valve Seat
				25	146-0379	1	Spring, Float Assist
				26	142-0592	1	Repair Kit (Includes Parts Marked †)

† - Parts Included in 142-0592 Repair Kit.
* - Parts Included in 142-0591 Gasket Kit.

Option 7
Fuel Puls

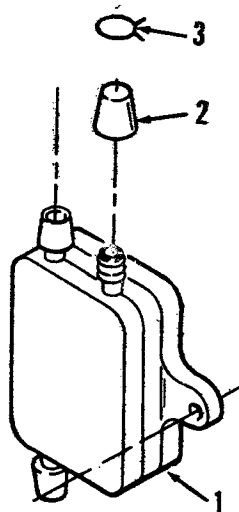

REF NO.	PART NO.	QTY USED	PART DESCRIPTION	REF NO.	PART NO.	QTY USED	PART DESCRIPTION
1	149-1982	1	Pump, Fuel - Vacuum, Pulse (Includes Cap and Clamp)	2	149-1321	1	Cap, Fuel Fitting
				3	503-0301	1	Clamp, Hose

Option 8 Clutch

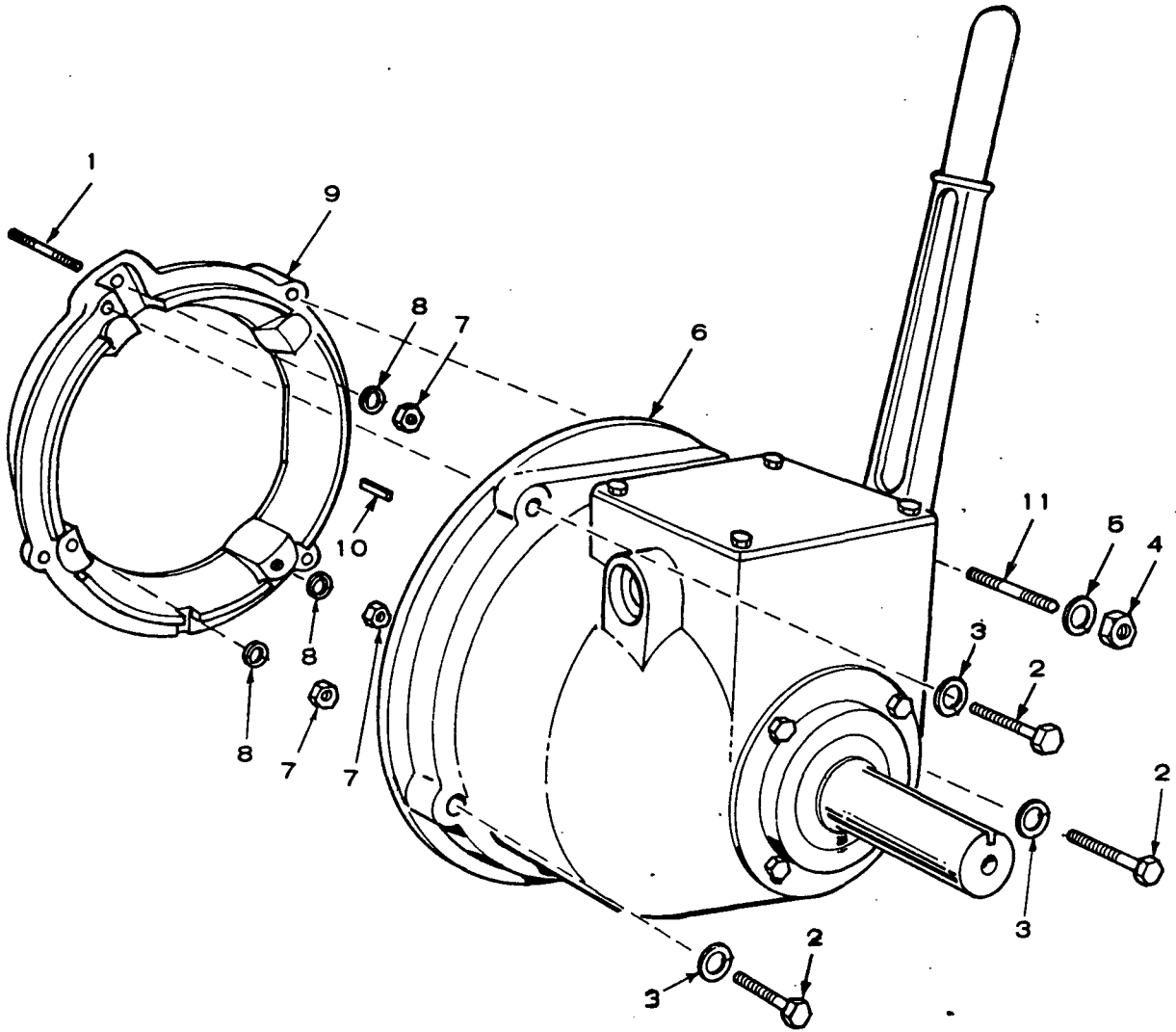

REF NO.	PART NO.	QTY USED	PART DESCRIPTION	REF NO.	PART NO.	QTY USED	PART DESCRIPTION
	190-0289	1	Kit, Clutch Assembly (Includes All Parts Except Crankshaft)	5	850-0050	1	Washer, Lock - Spring (3/8
1	520-0739	3	Stud (3/8-24 x 3/8-16 x 3")	6	190-0288	1	*Clutch Assembly
2	800-0075	3	Screw, Cap - Hex Head (7/16-14 x 2")	7	104-0091	3	Nut, Hex - Hardened (3/8-2
3	850-0055	3	Washer, Lock - Spring (7/16")	8	850-0050	3	Washer, Lock - Spring (3/8
4	104-0091	1	Nut, Hex - Hardened (3/8-24)	9	190-0171	1	Adapter, Clutch
				10	515-0041	1	Key, Drive - Special
				11	520-0738	1	Stud (3/8-24 x 3/8-16 x 4"

* - For Components, check nameplate and contact nearest Rockford Clutch Dealer.

Option 9
Fuel Tank (Side Mounted)

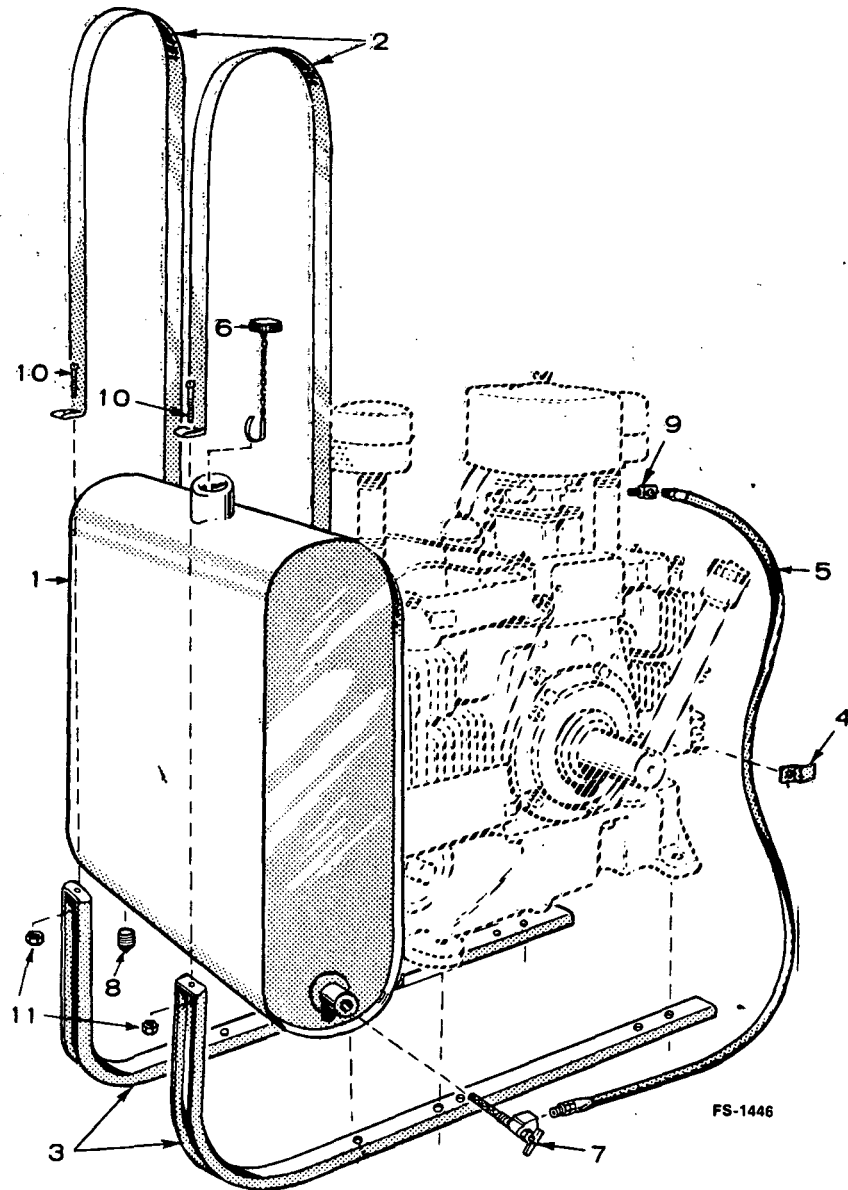

REF NO.	PART NO.	QTY USED	PART DESCRIPTION	REF NO.	PART NO.	QTY USED	PART DESCRIPTION
	159-0597	1	Kit, Fuel Tank	7	504-0013	1	Valve, Shut-off
1	159-0981	1	Tank, Fuel (Less Cap)	8	505-0057	1	Plug, Tank Drain
2	159-0596	2	Strap, Fuel Tank	9	502-0020	1	Elbow, Carburetor Inlet
3	159-0595	2	Bracket, Fuel Tank	10	813-0108	2	Screw, Machine - Round Head (#10-32 x 1-1/2")
4	134-0599	1	Clip, Fuel Line	11	870-0053	2	Nut, Hex (#10-32)
5	501-0008	1	Line, Fuel				
6	159-0020	1	Cap, Fuel Tank				

Option 10 Control (Engine)

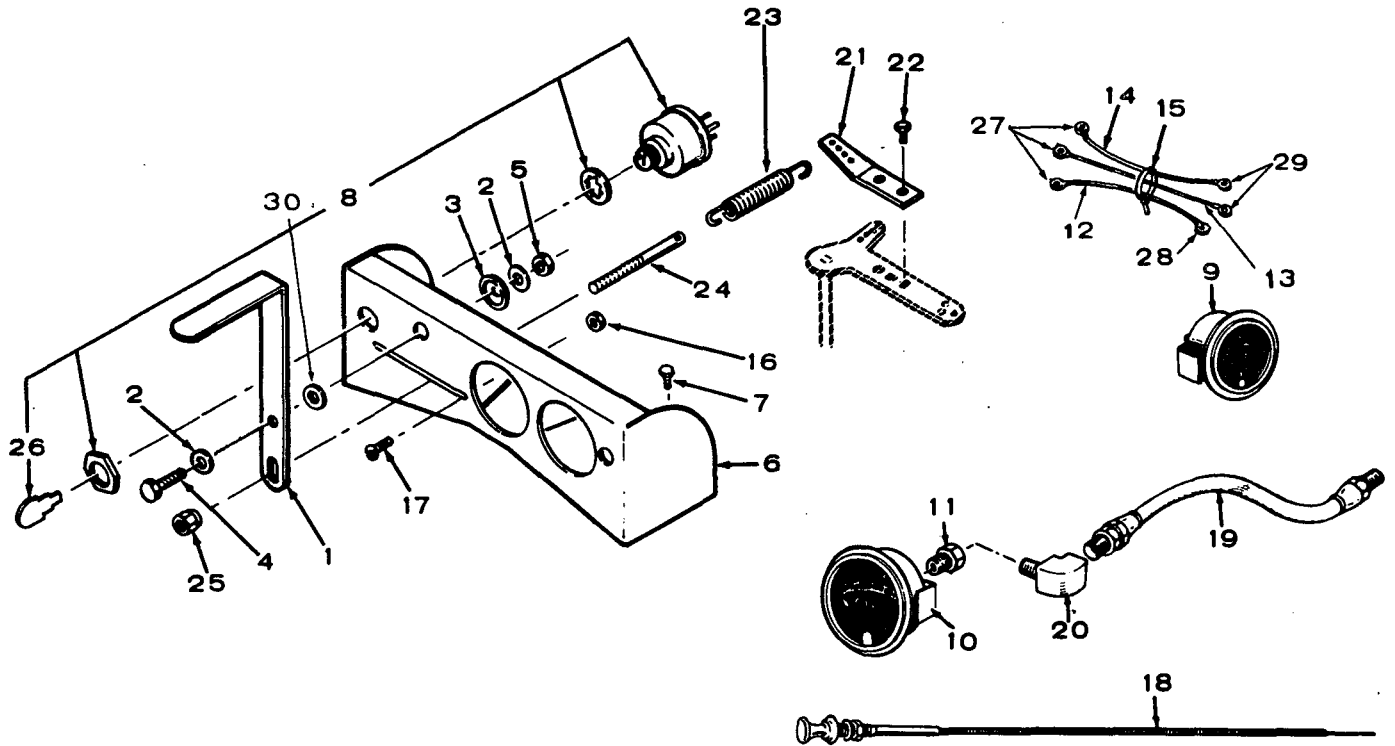

REF NO.	PART NO.	QTY USED	PART DESCRIPTION	REF NO.	PART NO.	QTY USED	PART DESCRIPTION
1	152-0198	1	Lever, Throttle Control	15	332-0942	1	Tie, Cable
2	526-0015	2	Washer, Flat (1/4" Screw)	16	870-0131	2	Nut, Hex (10-32)
3	152-0041	2	Washer, Tension - Cup	17	815-0199	2	Screw, Machine - Fillister Head (10-32 x 5/16")
4	800-0005	1	Screw, Cap - Hex Head (1/4-20 x 3/4")	18	153-0097	1	Cable, Choke
5	870-0065	1	Nut, Lock - Hex (1/4-20)	19	501-0004	1	Line, Oil - Flexible
6	301-4041	1	Panel, Control	20	502-0020	1	Elbow, Street (90°)
7	821-0009	2	Screw, Lock - Hex (1/4-20 x 5/16")	21	150-1544	1	Adapter, Governor Arm
8	308-0385	1	Switch and Key, Ignition	22	815-0194	2	Screw, Tapping (10-32 x 3/8)
9	302-0060	1	Ammeter, DC (20-0-20)	23	150-0098	1	Spring, Governor
10	193-0005	1	Gauge, Oil Pressure	24	150-0096	1	Stud, Speed Adjusting
11	502-0017	1	Connector, Inverted Female	25	150-0621	1	Nut, Special - Speed Adjusting Stud
12		1	Lead, Electrical - #16 Wire, .26" Lg.	26	308-0490	1	Key, Ignition Switch
13		1	Lead, Electrical - Switch to Coil - #16 Wire, 13" Lg.	27	332-0325	3	Terminal, Ring
14		1	Lead, Electrical - Switch to Ammeter - #16 Wire, 7" Lg.	28	332-1408	1	Terminal, Faston
				29	332-1993	2	Terminal, Receptacle
				30	526-0016	1	Washer, Flat (1/4" Screw)

See 150-1716
Control Panel Kit

Option 10A
Control (Engine)

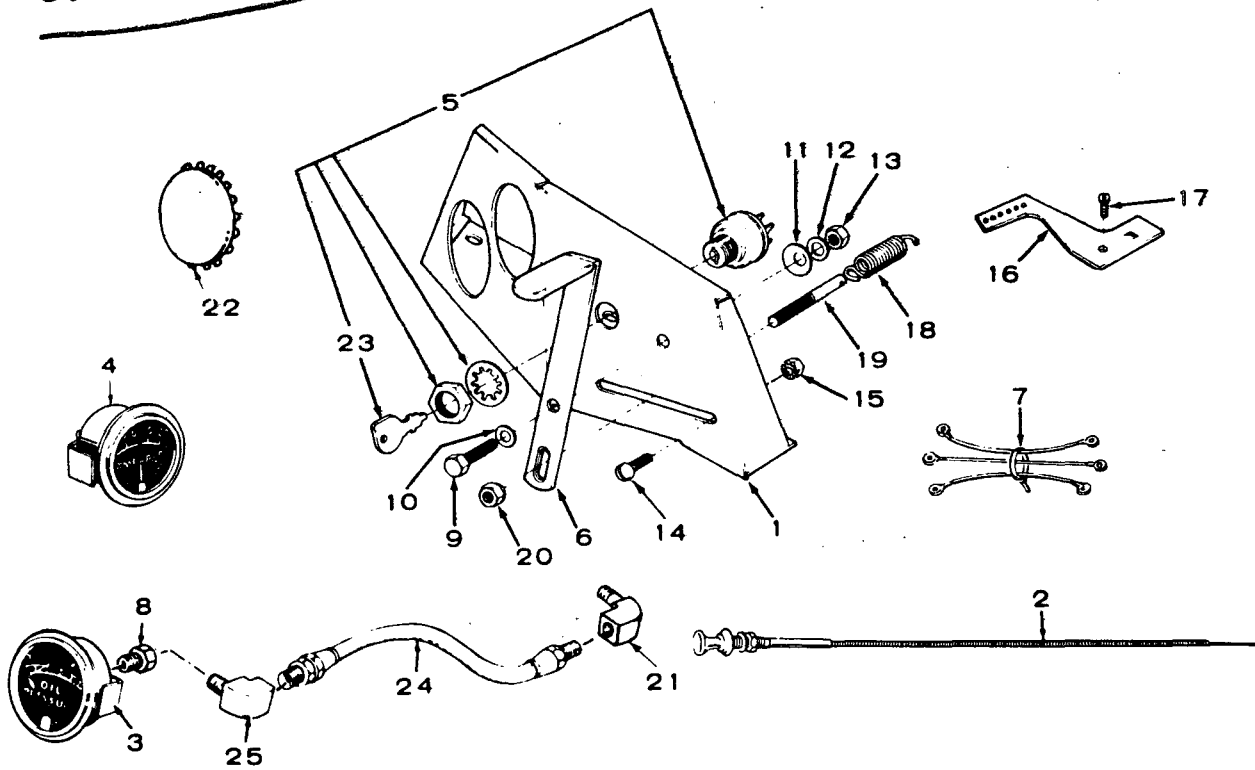

REF NO.	PART NO.	QTY USED	PART DESCRIPTION	REF NO.	PART NO.	QTY USED	PART DESCRIPTION
1	301-5065	1	Panel, Control	15	870-0131	2	Nut, Hex with ET (#10-32)
2	153-0097	1	Cable, Choke	16	150-1749	1	Extension, Governor Arm
3	193-0005	1	Gauge, Oil Pressure	17	815-0181	1	Screw, Tapping - Hex Head with ET (#10-32 x 1/2")
4	302-0060	1	Ammeter (20-0-20)	18	150-1214	1	Spring, Governor
5	308-0385	1	Switch, Ignition	19	152-0177	1	Stud, Speed Adjusting
6	152-0224	1	Lever, Throttle Control	20	150-0621	1	Nut, Speed Adjusting Stud
7	338-1219	1	Harness, Wiring	21	502-0005	1	Elbow, Inverted - Female (90°)
8	502-0051	1	Coupling, Female	22	517-0009	AR	Plug, Dot Button
9	800-0005	1	Screw, Cap - Hex Head (1/4-20 x 3/4")	23	308-0490	1	Key, Ignition Switch
10	526-0016	1	Washer, Flat (1/4" Screw)	24	501-0009	1	Line, Oil - Flexible (36" Lg)
11	152-0041	1	Washer, Tension - Cup	25	502-0065	1	Elbow, Inverted - Male (45°)
12	526-0015	2	Washer, Flat (1/4" Screw)		821-0010	4	Screw, Hex Washer Head - Self-Lock (Not Shown) Mounts Control Panel to Blower Housing (1/4-20" x 1/2")
13	870-0065	1	Nut, Hex - Self Locking (1/4-20)				
14	815-0199	2	Screw, Machine - Fillister Head (#10-32 x 5/16")				

Option 11
Oil Filter (Remote)

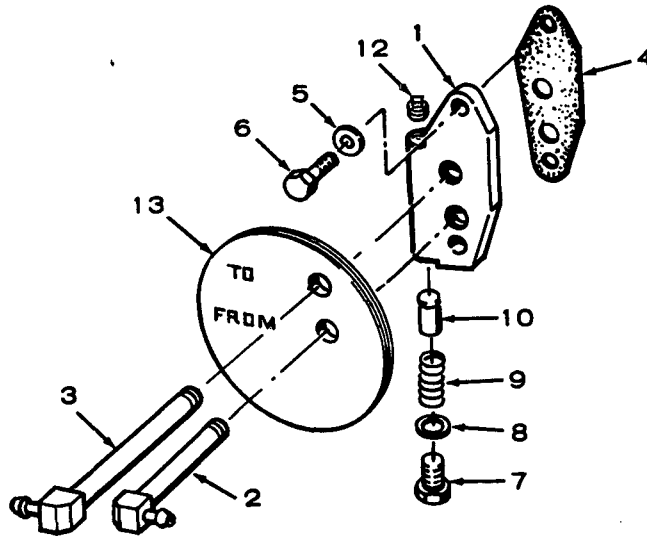

REF NO.	PART NO.	QTY USED	PART DESCRIPTION	REF NO.	PART NO.	QTY USED	PART DESCRIPTION
1	122-0369	1	Adapter, Remote Oil Filter	7	801-0047	1	Screw, Cap - Hex Head (3/8-24 x 5/8")
2	502-0580	1	Elbow, Adapter (90°)	8	526-0066	1	Washer, Flat - Copper (3/8" Screw)
3	502-0581	1	Elbow, Adapter (90°)	9	120-0140	1	Spring, By-Pass Valve
4	122-0375	1	Gasket, Adapter	10	120-0398	1	Valve, By-Pass
5	526-0065	2	Washer, Flat - Copper (5/16" Screw)	12	505-0057	1	Plug, Pipe - Square Head
6	800-0031	2	Screw, Cap - Hex Head Prior to 6/86 (5/16-18 x 1-1/2")	13	508-0184	1	Grommet, Air Seal
	800-0030	2	Begin 6/86 (5/16-18 x 1-1/4")				

NOTE: Hoses vary with each installation. Purchase locally, hoses with a minimum pressure rating of 150 PSI (1035 kPa).

Option 12
Start Motor Components (Heavy Duty)
(191-120)

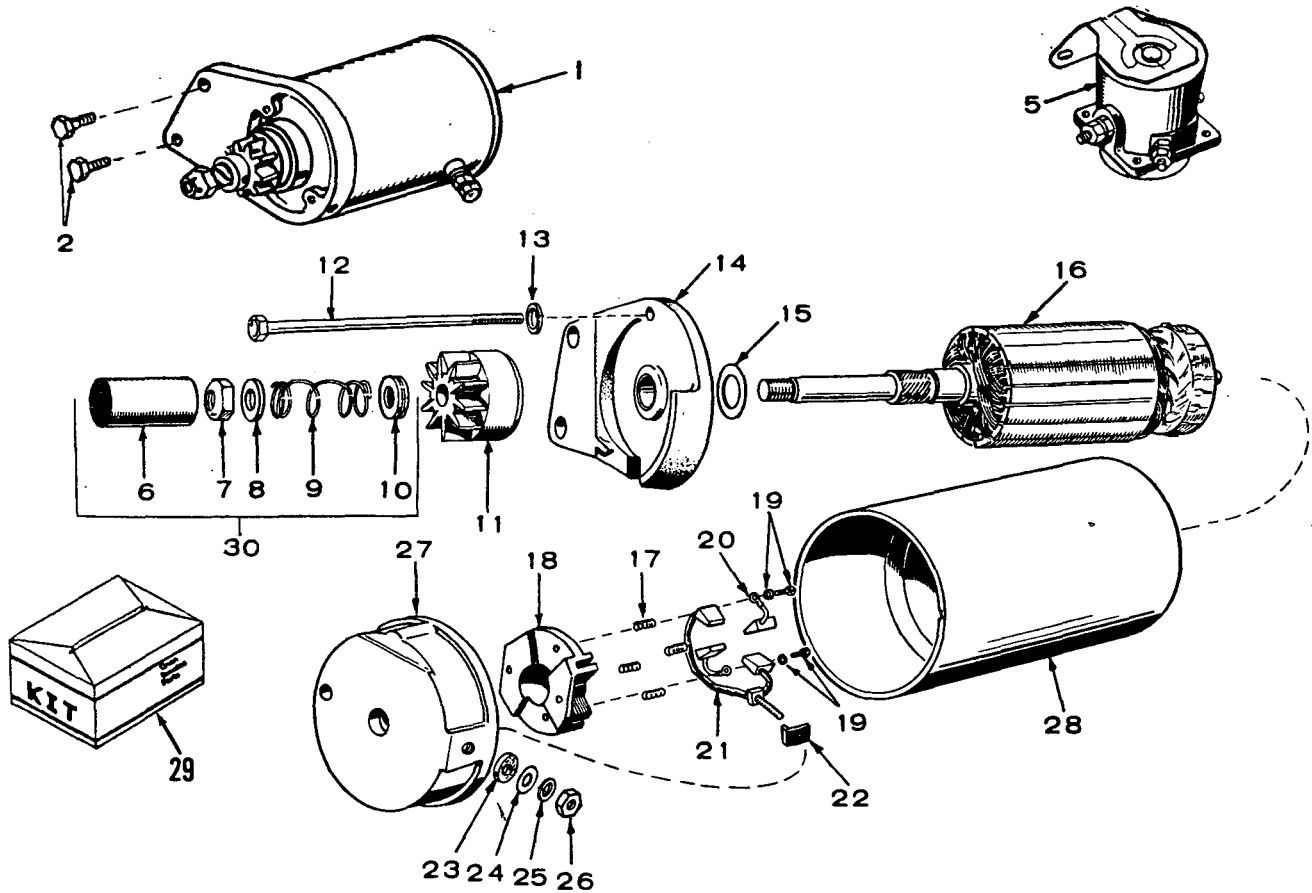

REF NO.	PART NO.	QTY USED	PART DESCRIPTION	REF NO.	PART NO.	QTY USED	PART DESCRIPTION
1	191-1205	1	Motor, Starter (Complete)	20	§	2	†*Brush, Ground
2	815-0570	2	Screw, Cap - Hex Washer Head (5/16-18 x 1")	21	§	1	†*Stud and Brush Assembly, Input
5	307-1031	1	Relay, Start Solenoid	22	§	1	†Bushing, Insulation - Input Stud
6	§	1	xCover, Dust	23	§	1	†Washer, Insulation - Input Stud
7	§	1	xNut, Stop	24	§	1	†Washer, Flat - Input Stud
8	§	1	xWasher, Stop Nut	25	§	1	†Washer, Lock - Input Stud
9	§	1	xSpring, Anti-drift	26	§	1	†Nut, Securing - Input Stud
10	§	1	xSpacer, Dust Cover	27	191-1155	1	Cap Assembly, Commutator (Includes Parts Marked †)
11	191-1156	1	Drive Assembly	28	§	1	Housing, Starter Motor
12	191-1157	2	Screw, Hex Cap	29	191-1222	1	Repair Kit, Brush, Spring and Stud (Includes Parts Marked *)
13	850-0040	2	Washer, Lock				
14	191-1037	1	Cap Assembly, Drive End				
15	191-1038	1	Washer, Armature Thrust				
16	191-1154	1	Armature				
17	§	4	†*Spring, Brush	30	191-1359	1	Dust Cover Assembly (Includes Parts Marked x)
18	§	1	†Brush Holder				
19	§	2	†Screw and Lockwasher				

† - Included in the 191-1155 Cap Assembly.
* - Included in the 191-1222 Brush, Spring and Stud Kit.
x - Included in 191-1359 Dust Cover Assembly.
§ - Not Sold Separately.

Option 13
Carburetor Components
(Adjustable Main Jet)

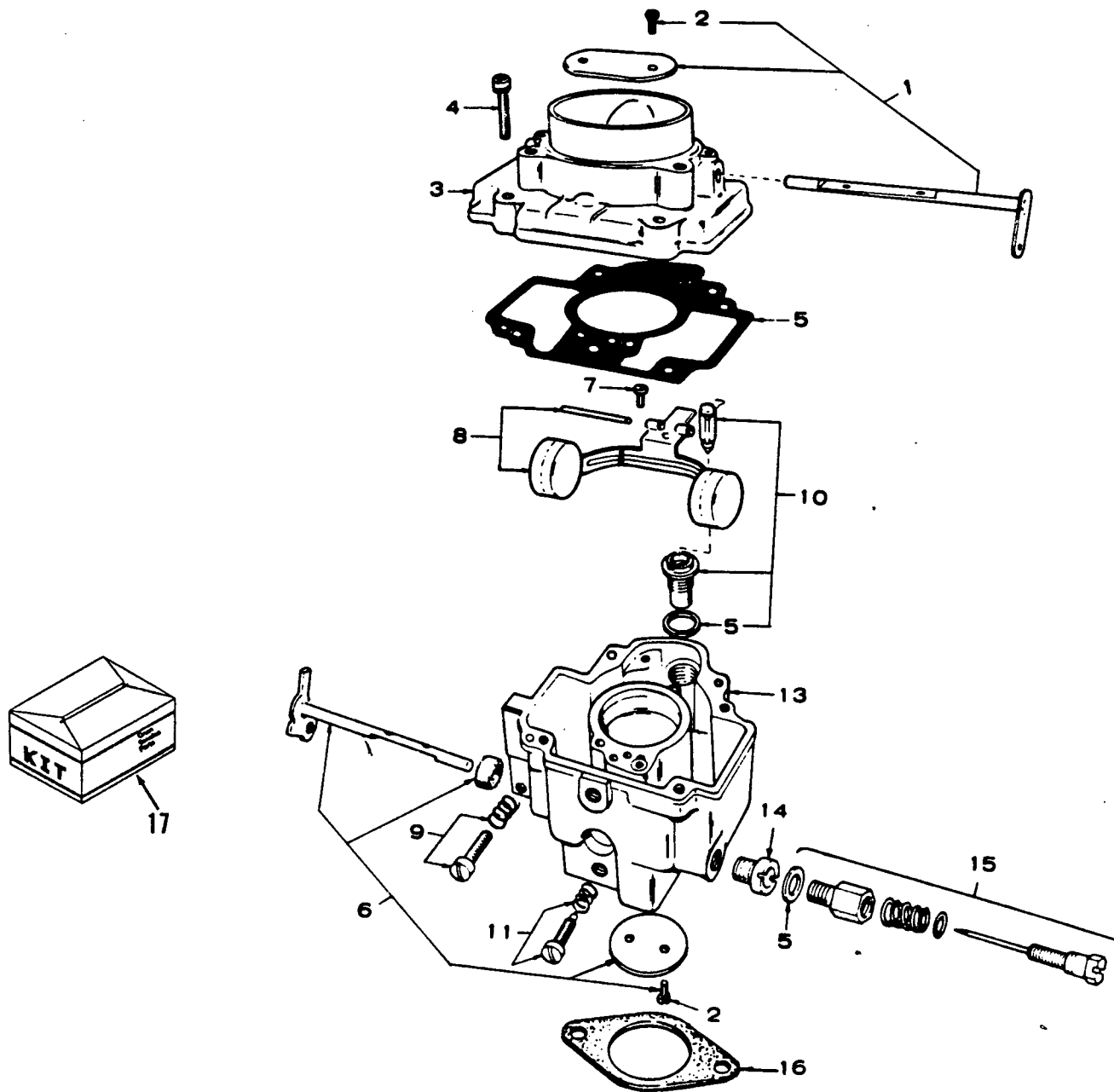

REF. NO.	PART NO.	QTY. USED	PART DESCRIPTION	REF. NO.	PART NO.	QTY. USED	PART DESCRIPTION
	146-0311	1	Carburetor, Complete (Includes Mounting Gasket)	9	146-0261	1	Idle Speed Adjusting Screw Package
1	146-0281	1	Choke Shaft Package	10	146-0289	1	*Valve and Seat Package
2	146-0142	4	Screw, Valve Mounting	11	146-0209	1	*Idle Needle Package
3		1	Intake, Air (Not Sold Separately)	13		1	Body (Not Sold Separately)
4	146-0247	4	Screw, Body to Intake	14	146-0238	1	Jet Power
5	146-0220	1	Gasket Kit	15	146-0282	1	*Power Needle Package (var.)
6	146-0259	1	Throttle Shaft Package	16	154-0733	1	Gasket, Carburetor Mounting
7	146-0222	1	*Screw, Lever Pin	17	146-0292	1	Kit, Repair (Includes Parts Marked *)
8	146-0262	1	Float Package				

* - Parts Included in 146-0292 Repair Kit.

down draft
ca

Option 10A
Carburetor Components
(Fixed Main Jet)

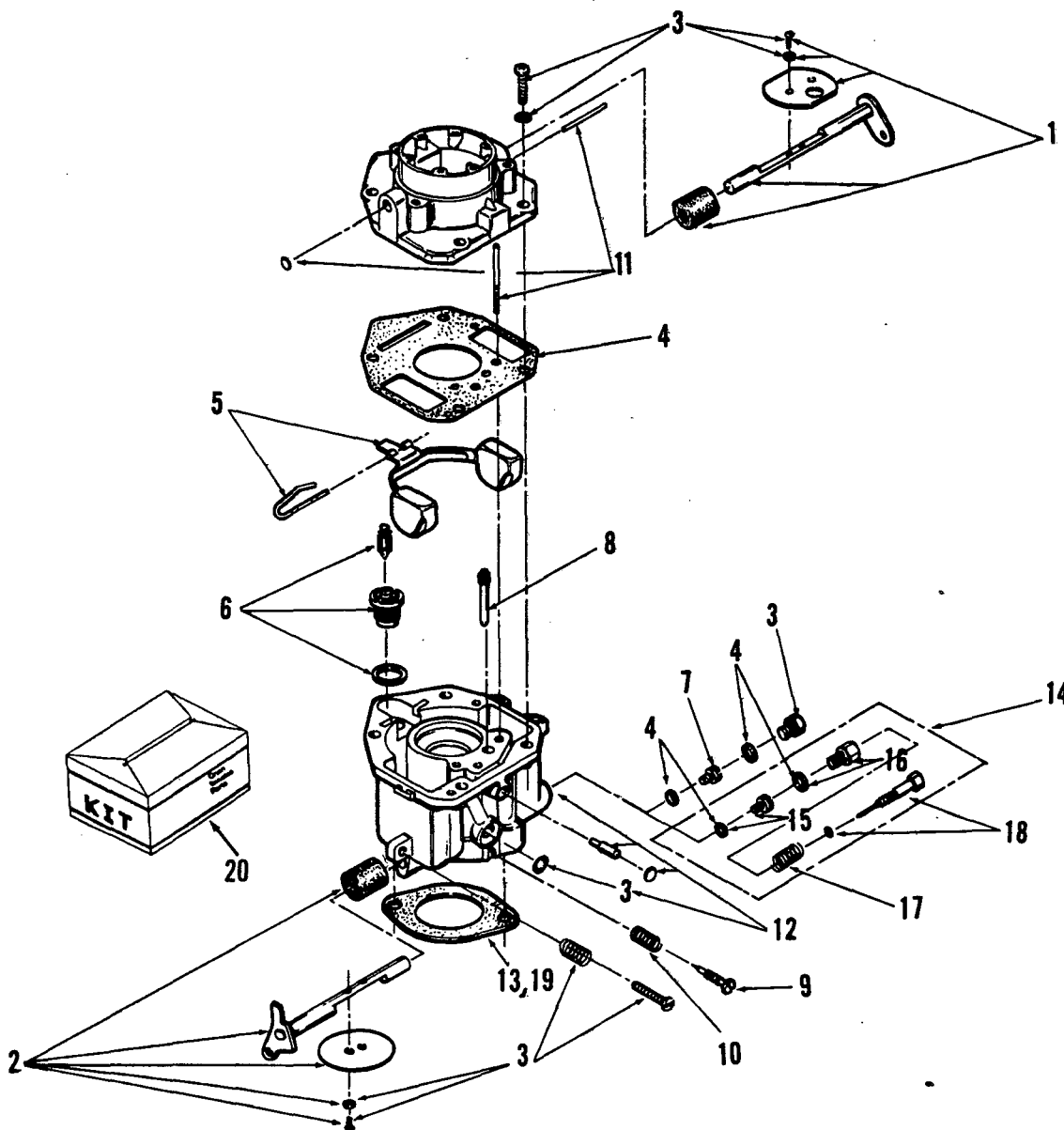

FS-1440

REF NO.	PART NO.	QTY USED	PART DESCRIPTION	REF NO.	PART NO.	QTY USED	PART DESCRIPTION
	146-0381	1	Carburetor, Complete (Includes Mounting Gasket)	12		1	Body (Not Sold Separately)
1	146-0377	1	Choke, Shaft Kit	13	154-0733	1	*Gasket, Carburetor Mounting
2	146-0324	1	Throttle Shaft Kit	14	146-0327	1	Variable Jet Kit - Optional (High Altitude Application) (Includes Parts Marked +)
3	146-0322	1	*Screw and Plug Kit	15	146-0343	1	Power Jet, Variable (Includes Gasket)
4	146-0326	1	*Gasket Kit	16	146-0340	1	Retainer, Power Needle (Includes Gasket)
5	146-0325	1	Float Kit	17	146-0341	1	Spring, Power Needle
6	146-0329	1	*Valve and Seat Kit	18	146-0342	1	Needle, Complete - Power
7	146-0396	1	Jet, Power	19	145-0438	1	*Gasket, Carburetor Mounting
8	146-0337	1	Jet, Idle	20	146-0356	1	Kit, Repair (Includes Parts Marked *)
9	146-0335	1	*Needle, Idle Adjusting				
10	146-0331	1	*Spring, Idle Adjusting Needle				
11		1	Intake, Air (Not Sold Separately)				

* - Parts Included in 146-0356 Repair Kit.
~~Parts Included in 146-0327 Variable Jet Kit.~~

Option 14
Fuel Line Filter

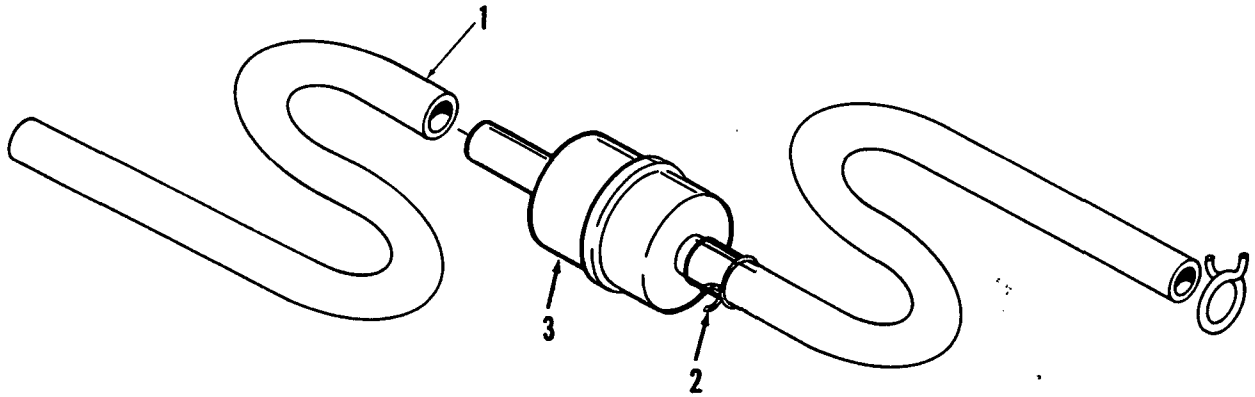

FS-1522

REF NO.	PART NO.	QTY USED	PART DESCRIPTION	REF NO.	PART NO.	QTY USED	PART DESCRIPTION
1	503-0707	2	Hose (1/4" ID x 7/16" OD x 12" Long)	2	503-0731	3	Clamp, Hose (7/16")
				3	149- 2005	1	Filter, Fuel

2206-01

another free manual from www.seatractormanuals.com

Option 15
Choke Control (Front Pull)

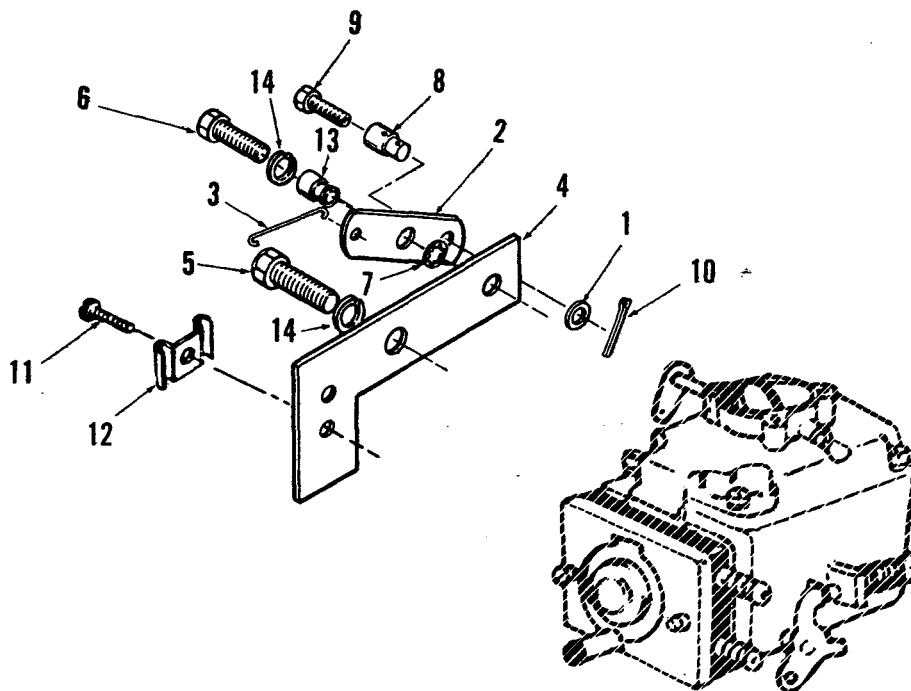

FS-1131-1

REF NO.	PART NO.	QTY USED	PART DESCRIPTION	REF NO.	PART NO.	QTY USED	PART DESCRIPTION
1	526-0140	1	Washer, Flat Use with Swivel 152-0155	7	854-0010	1	Washer, Lock - IT (#10) Use with Swivel 152-0155
	526-0108	2	Use with Choke Lever 153-0501	8	152-0155	1	Swivel, Choke Lever
2	153-0523	1	Lever, Choke Use with Swivel 152-0155	9	815-0104	1	Screw, Machine - Fillister Head (#8-32 x .31")
	153-0501	1	Use without Swivel 152-0155	10	516-0059	1	Pin, Cotter
3	153-0500	1	Link, Choke	11	815-0359	1	Screw, Tapping - Slotted Hex Washer Head (#10-32 x 7/8")
4	153-0524	1	Bracket, Choke Cable	12	153-0514	1	Clip, Choke Cable
5	812-0099	1	Screw, Round Head (10-24 x 7/16")	13	153-0502	1	Bushing, Flanged - Use with Choke Lever 153-0501
6	815-0480	1	Screw Pan Head (10-32 x .34") - Use with Choke Lever 153-0523	14	850-0030	2	Washer, Lock (#10) - Use with Choke Lever 153-0501
	812-0100	1	Round Head (10-24 x 1/2") - Use with Choke Lever 153-0501				

Option 16
Ignition Breaker Box (Side Adjustable)

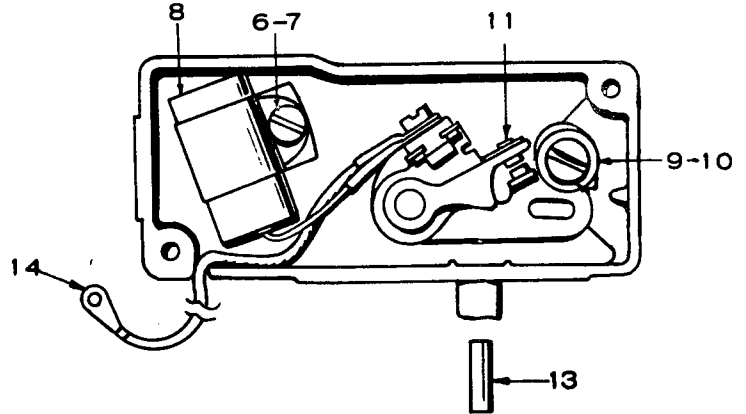
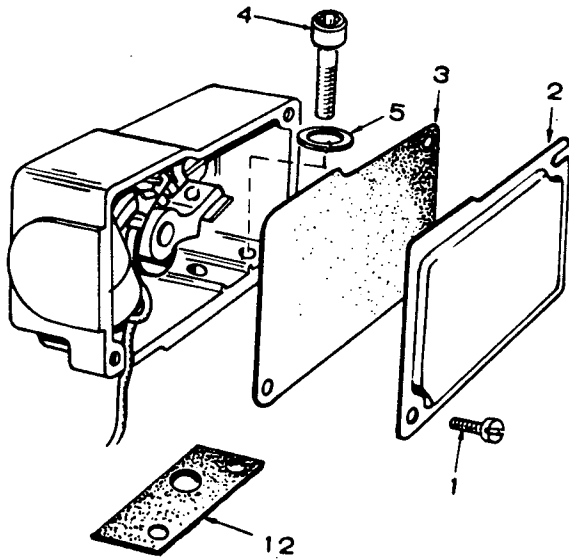

REF NO.	PART NO.	QTY USED	PART DESCRIPTION
	160-1158	1	Box Assembly, Breaker (Includes Parts Marked *)
1	815-0358	2	*Screw, Tapping - Hex Head, Slotted (#8-32 x 5/16")
2	160-1149	1	*Cover, Breaker Box
3	160-1148	1	*Gasket, Cover
4	802-0034	2	*Screw, Cap - Socket Head (1/4-20 x 3/4")
5	850-0038	2	*Washer, Lock - Spring (1/4")
6	815-0403	1	*Screw, Tapping - Pan Head (#8-32 x 5/16")
7	850-0025	1	*Washer, Lock - Spring (#8)

REF NO.	PART NO.	QTY USED	PART DESCRIPTION
8	312-0069	1	*Condenser, Ignition
9	870-0221	1	*Nut, Hex with External Tooth Lockwasher (#8-32)
10	815-0405	1	*Screw, Machine - Pan Head, Cross-Recessed (#8-32 x 1/2)
11	160-1154	1	*Point Set, Breaker
12	160-1150	1	*Gasket
13	160-1151	1	Plunger, Breaker Points
14	336-2378	1	Lead, Breaker Box to Coil
	160-1161	1	Tune-Up Kit (Includes Points and Condenser)

* - Parts Included in 160-1158 Breaker Box Assembly

Option 7 Support and Terminal Block Assembly

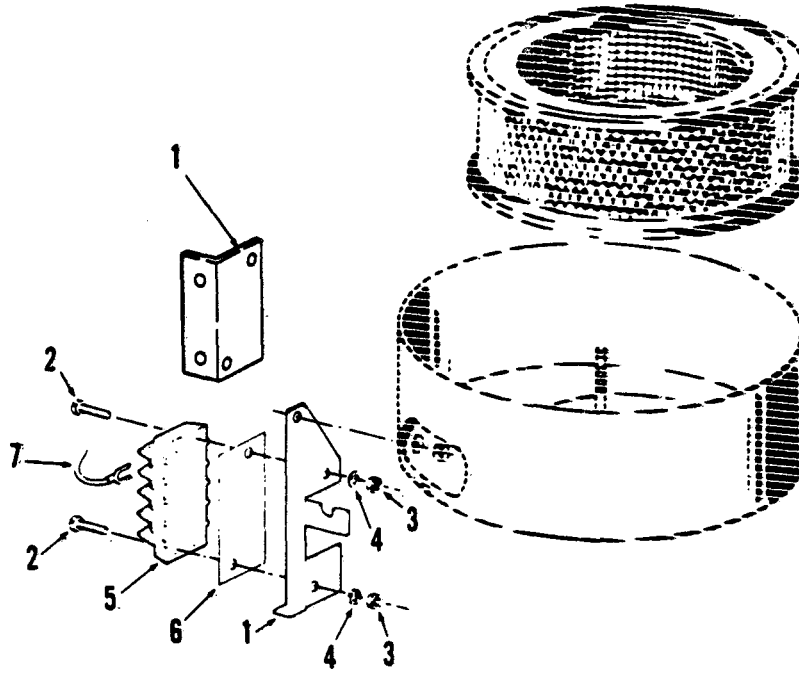

ES-1481

REF NO.	PART NO.	QTY USED	PART DESCRIPTION	REF NO.	PART NO.	QTY USED	PART DESCRIPTION
1	140-1644	1	Support, Air Cleaner Units with Air Cleaner Housing	4	853-0005	2	Washer, Lock - ET (#8)
	301-5936	1	Units without Air Cleaner Housing	5	332-0537	1	Block Terminal (4 Place)
2	812-0081	2	Screw, Machine - Round Head (#8-32 x 5/8")	6	332-2208	1	Strip, Marker
3	860-0008	2	Nut, Hex (#8-32)	7	336-4385	1	Lead Assembly Alternator
					334-0028	1	Ignition

Option 18 Ignition (Magneto)

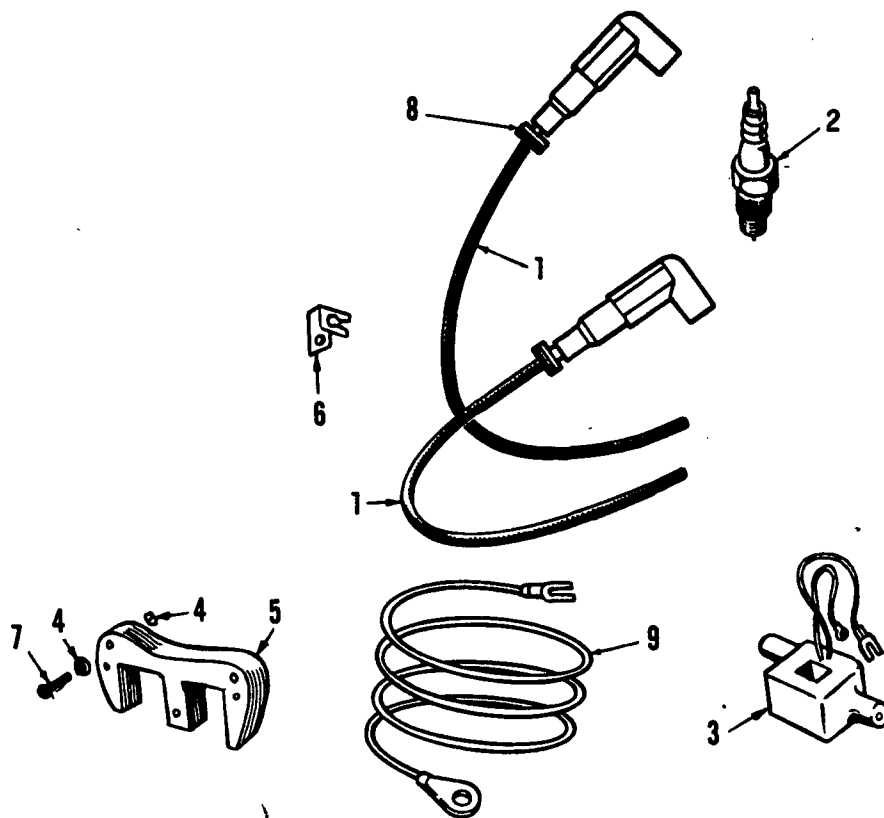

REF NO.	PART NO.	QTY USED	PART DESCRIPTION
	160-1306	1	Stator Assembly (Includes Parts Marked *)
1	167-1595	2	Cable, Spark Plug R.H.
2	167-0298	2	Spark Plug
3	160-1305	1	*Coil, Magneto Stator
4			Washer, Flat - Stator
	526-0015	2	1/4" Screw
	526-0184	2	17/64 ID x 5/8 OD x .1345" Thk)

REF NO.	PART NO.	QTY USED	PART DESCRIPTION
5	160-0749	1	*Pole Shoe, Stator - Magneto
6	167-0188	4	Clip, Spark Plug Cable
7	815-0259	2	Screw, Hex Cap
8	508-0095	2	Grommet, Rubber
9	336-8466	1	Lead, Magneto to Ignition Breaker

* - Parts Included in the 160-1306 Stator Assembly

Option 19 Remote Air Cleaner Adapter

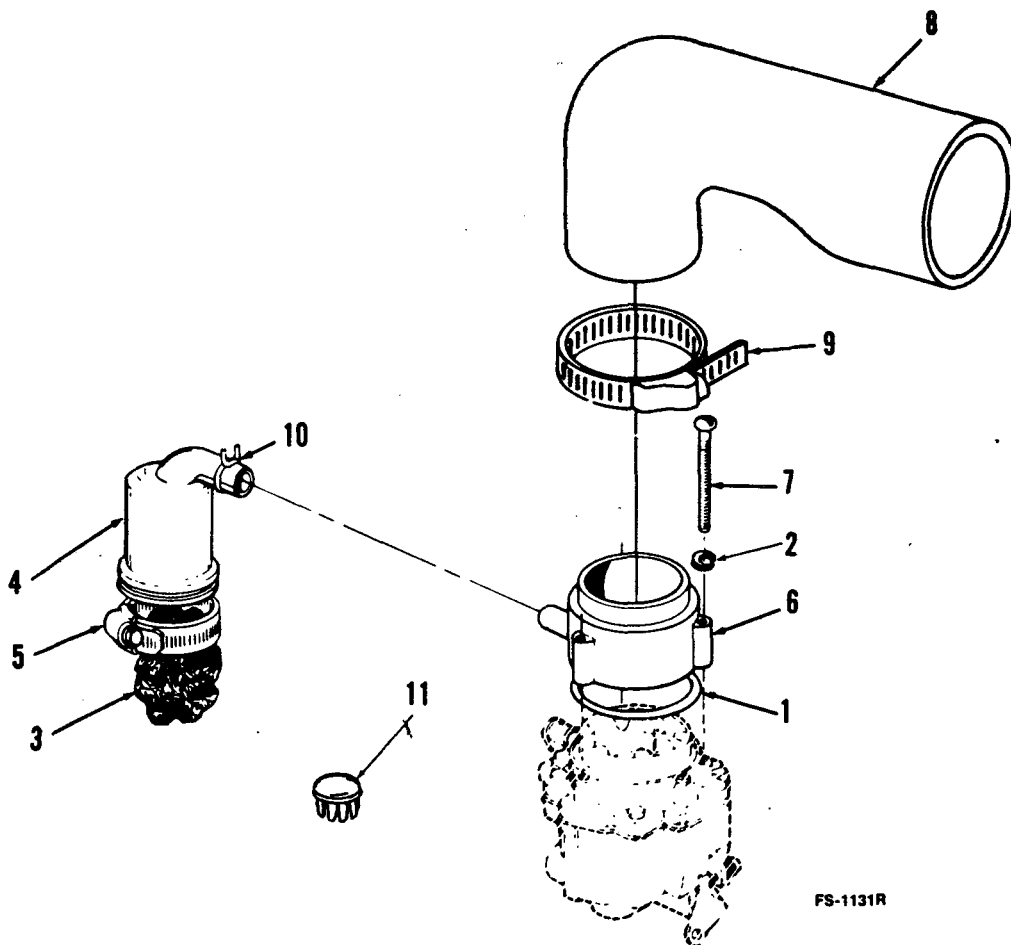

REF NO.	PART NO.	QTY USED	PART DESCRIPTION	REF NO.	PART NO.	QTY USED	PART DESCRIPTION
	140-1915	1	Kit, Remote Air Cleaner Adapter (Includes Parts Marked *)	6	140-1714	1	*Adapter, Carburetor Air Intake
				7	813-0106	3	*Screw, Machine - Round Head (#10-32 x 1-1/8")
1	509-0145	1	Seal, O-Ring	8	140-1428	1	*Elbow, Air Intake
2	850-0030	3	*Washer, Lock - Spring (#10)	9	503-0274	1	*Clamp, Hose - Air Intake
3	123-1417	1	*Filter, Breather Tube	10	503-0171	1	*Clamp, Hose
4	123-1539	1	*Tube, Crankcase Breather	11	517-0151	1	*Plug, Dot Button - Blower Housing Air Hole
5	503-0107	1	Clamp, Breather Tube				

* - Parts Included in 140-1915 Remote Air Cleaner Adapter Kit.

Miscellaneous Options

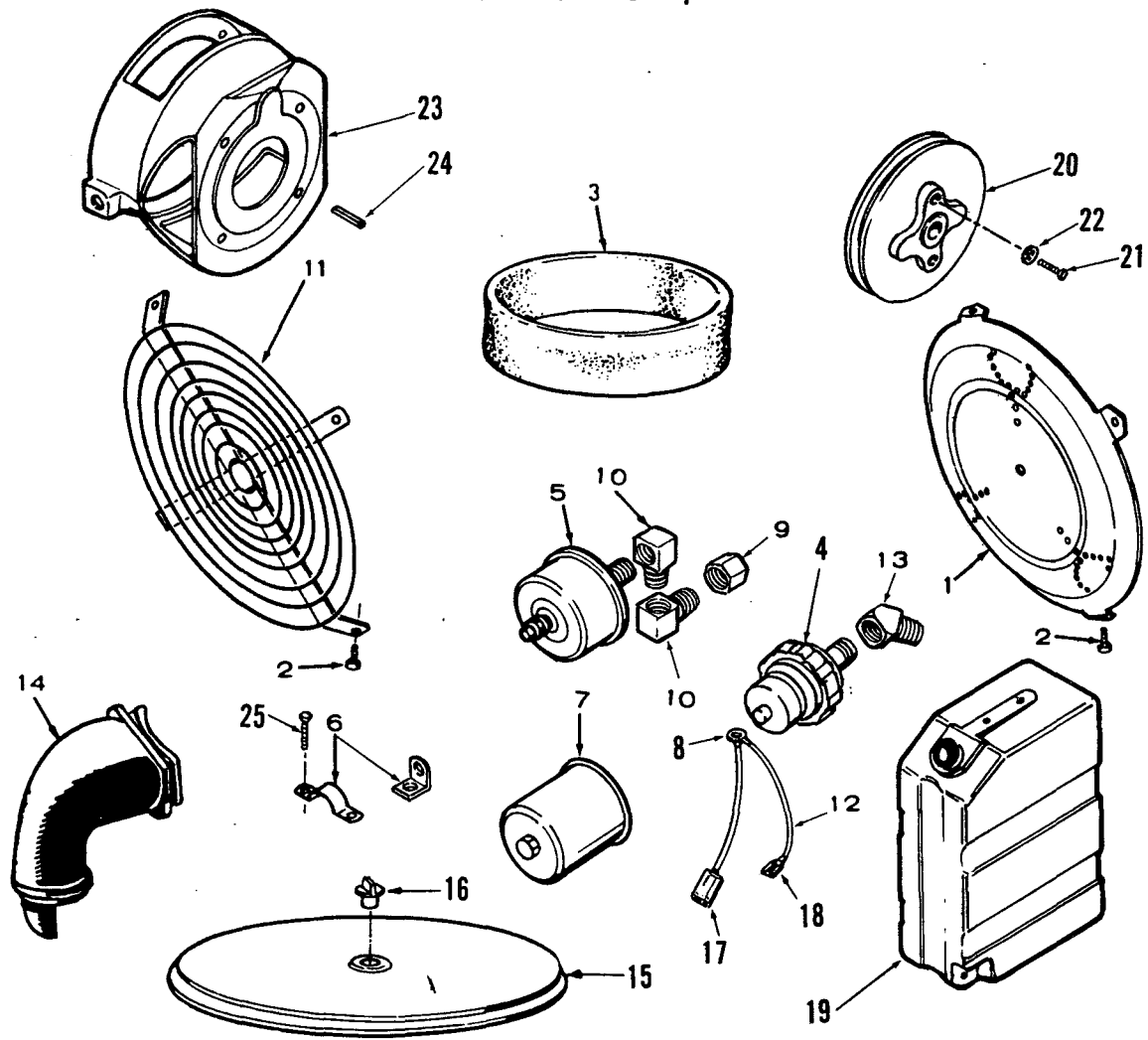

Miscellaneous Options

REF NO.	PART NO.	QTY USED	PART DESCRIPTION	REF NO.	PART NO.	QTY USED	PART DESCRIPTION
1	134-3213	1	Guard, Flywheel - Stationary	13	502-0053	1	Elbow, Street - 45°
2	815-0378	4	Screw, Tapping - Hex Head (#14 x 1/2")	14	140-1169	1	Tube, Air Intake with Debris Lip
3	140-1218	1	Wrapper, Filter Element - Dry Type	15	140-1747	1	Cover, Air Cleaner - Moisture Proof
4	309-0237	1	Switch, Low Oil Pressure Close at 8-10 PSI at Lowering Pressure	16	140-1750	1	Knob, Air Cleaner - Moisture Proof
	309-0510	1	Open at 4.5-7.5 PSI on Increasing Pressure	17	332-1408	1	Terminal, Receptacle
5	193-0108	1	Sender, Electric Oil Pressure Gauge	18	332-1279	1	Terminal, Spade
6	403-1490	2	Bracket, Lifting One Mounting Hole	19	159-1150	1	Tank, Fuel - Plastic (3.5 Gallon Capacity)
	403-1021	2	Two Mounting Holes	20	191-1210	1	Pulley, Drive - Alternator
7	122-0406	1	Filter, Oil (With Hex Nut)	21	800-0032	2	Screw, Hex Head Cap (5/16-18 x 1-3/4")
8	332-0152	1	Terminal, Ring	22	850-0045	2	Washer, Lock (5/16")
9	502-0175	1	Adapter, Pipe	23	190-0266	1	Housing, Clutch - Use with Warner 3-speed
10	502-0020	2	Elbow, Street - 90°	24	515-0146	1	Key, Drive - Units with Clutch
11	134-3527	1	Guard, Flywheel - Stationary (Wire Type) Use without PTO	25	800-0034	2	Screw, Cap - Hex Head (5/16-18 x 2-1/4") One Mounting Hole Lifting Bracket
	134-4134	1	Use with PTO		800-0034	4	Two Mounting Holes Lifting Bracket
12		1	Lead Assembly, Low Oil Pressure Switch - #16 Wire, 12" Lg (2) or 15" Lg (1)				

Miscellaneous Exhaust Options

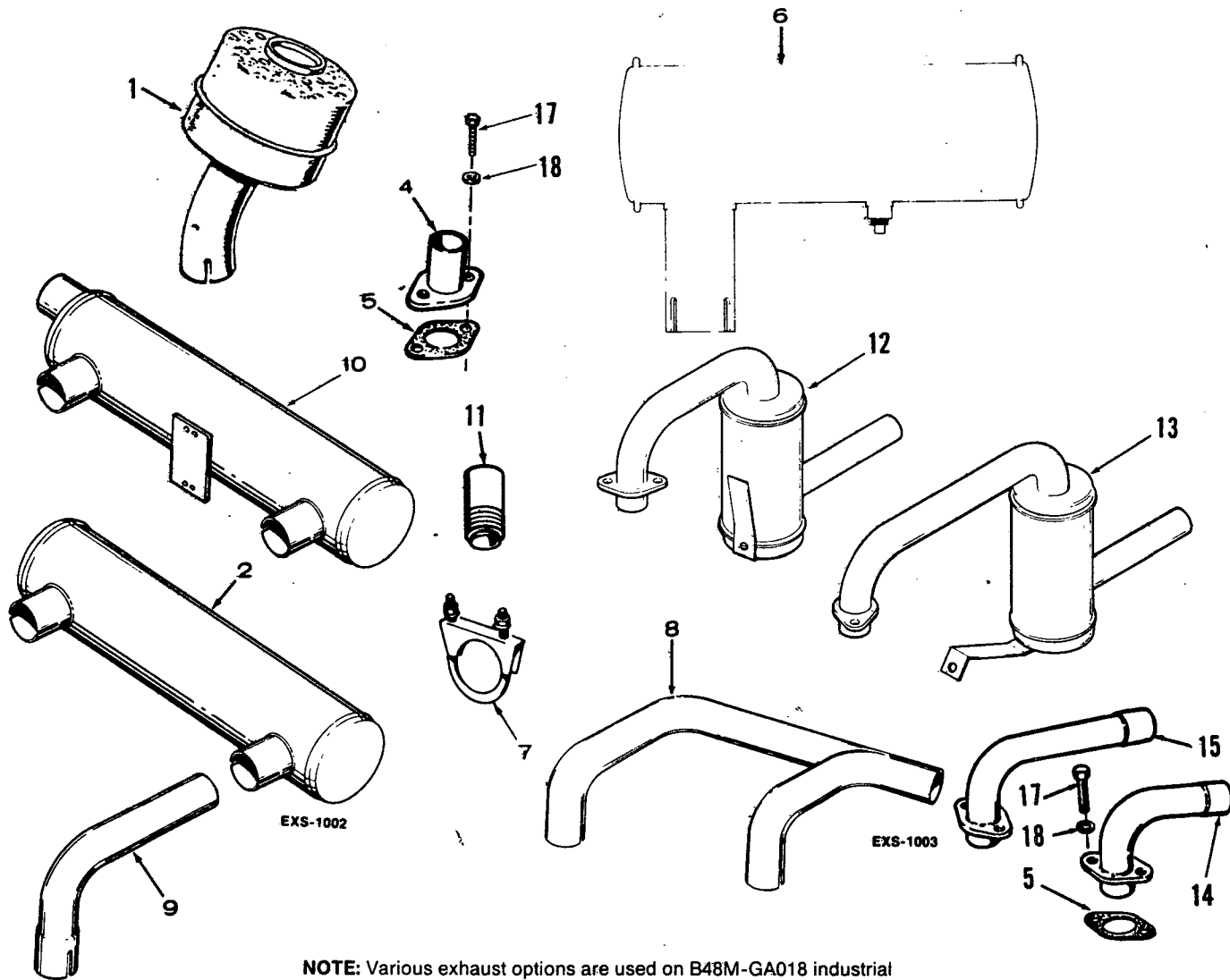

NOTE: Various exhaust options are used on B48M-GA018 industrial engines. Select according to illustration.

REF NO.	PART NO.	QTY USED	PART DESCRIPTION	REF NO.	PART NO.	QTY USED	PART DESCRIPTION
1	155-1570	2	Muffler, Exhaust	9		1	Pipe, Exhaust (90°)
2	155-1692	1	Muffler, Exhaust		155-1703	1	Left
4	154-1958	2	Adapter, Exhaust (Flange Type)		155-1704	1	Right
5	154-1725	2	Gasket, Exhaust Adapter	10	155-1848	1	Muffler, Crossover
6	155-1697	2	Muffler, Exhaust - Raygun	11	505-0775	2	Nipple, Half - Exhaust
	155-1693	2	With Spark Arrestor		505-0755	2	1" x 1-13/16"
7	155-1256	2	Without Spark Arrestor		155-1381	2	1" x 3"
	155-1257	2	Clamp, Muffler	12	155-1722	1	1" x 3" (Includes Insert)
			1-1/4"	13	155-1723	1	Muffler - RH
8			1-3/8"	14	154-2128	1	Muffler - LH
			Manifold, Exhaust - Crossover	15	154-2129	1	Adapter, Exhaust - Right
	154-1986	1	Left Rear Outlet				(1-1/4" OD Outlet)
	154-1669	1	Left Front Outlet	17	800-0026	4	Adapter, Exhaust - Left
	154-1986	1	Right Front Outlet				(1-1/4" OD Outlet)
	154-1669	1	Right Rear Outlet	18	850-0045	4	Screw, Cap - Hex Head
							(5/16-18" x 3/4")
							Washer, Lock - Spring (5/16")

Numerical Index

Part No.	Page	Part No.	Page	Part No.	Page	Part No.	Page
101-0405	5	110-1824-02	5	122-0360	13	142-0334	29
101-0415	5	110-1824-05	5	122-0369 <i>NS</i>	35	142-0523 <i>F¹⁰</i>	29
101-0430	5	110-1824-10	5	122-0375	13	142-0534 <i>F3</i>	17
101-0432	5	110-1824-25	5	122-0375	35	142-0534	29
101-0432-02	5	110-1879	5	122-0406	47	142-0535	17
101-0432-10	5	110-1921	5	122-0438	13	142-0535	29
101-0432-20	5	110-1955	5	122-0645	13	142-0536	17
101-0432-30	5	110-2274	5	123-1173	5	142-0536	29
101-0437	5	110-2287	5	123-1174	5	142-0537	17
101-0439	5	110-2368	5	123-1175	5	142-0538	17
101-0450	5	110-2438	5	123-1277	15	142-0538	29
101-0450-02	5	110-2563	5	123-1292	13	142-0539	17
101-0450-10	5	110-2564	5	123-1417	15	142-0539	29
101-0450-20	5	110-3148	5	123-1417	44	142-0540 <i>F¹⁰</i>	17
101-0450-30	5	110-3151	5	123-1539	44	142-0541	17
101-0551	5	<i>blak</i> 110-3154 <i>no stick</i>	5	134-0599	32	142-0542	17
102-0850	13	110-3161	5	134-3213	47	142-0544	17
102-1200	13	110-3181	5	134-3400	11	142-0544	29
103-0408	7	112-0186	6	134-3518	11	142-0545	17
103-0738	7	112-0186-05	6	134-3527 <i>F¹⁰</i>	47	142-0546	17
104-0032	9	112-0186-10	6	134-3582	11	142-0546	29
104-0043	9	112-0186-20	6	134-3583	11	142-0548	17
104-0091	31	112-0186-30	6	134-3749	11	142-0548	29
104-0170	9	112-0186-40 <i>F¹⁰</i>	6	134-3920	9	142-0549	17
104-0575	5	112-0229	6	134-4134	47	142-0549	29
104-0614	9	113-0189 <i>NS</i>	6	134-4371	11	142-0550	17
104-0776	5	113-0189-05	6	134-4400	11	142-0550	29
104-0779	9	113-0189-10	6	134-4734	9	142-0551	17
104-1028	9	113-0189-20 <i>F¹⁰</i>	6	140-1168	15	142-0552 <i>F¹⁰</i>	17
104-1348	9	113-0189-30 <i>NS</i>	6	140-1169	47	142-0553	17
104-1349	9	113-0189-40 <i>F¹⁰</i>	6	140-1198	15	142-0553	29
104-1351	9	114-0240	6	140-1213	15	142-0554	17
104-1352	9	114-0257	6	140-1215	15	142-0554	29
104-1353	9	114-0257-10	6	140-1216	15	142-0555	17
104-1359	9	114-0257-20	6	140-1218	47	142-0559	29
105-0332	8	114-0257-30	6	140-1313	15	142-0570 <i>NS</i>	17
105-0402	8	115-0006	5	140-1428	44	142-0571	17
105-0541	8	115-0006-02 <i>F¹⁰</i>	5	140-1549	15	142-0572	17
110-0068	5	115-0006-05 <i>NS</i>	5	140-1644	42	142-0572	29
110-0197	5	120-0140	13	140-1714	44	142-0591	29
110-0197-02 <i>F¹⁰</i>	5	120-0140	35	140-1747	47	142-0592	29
110-0197-05 <i>F¹⁰</i>	5	120-0161	13	140-1750	47	142-0660	15
110-0197-10 <i>F¹⁰</i>	5	120-0398	13	140-1915	44	142-0660	17
110-0197-25 <i>F¹⁰</i>	5	120-0398	35	142-0016	17	142-0661	26
110-0539	5	120-0491	13	142-0016	29	142-0661	29
110-0639	5	120-0713	13	142-0064	17	145-0438	15
110-0893	5	120-0735	5	142-0064	29	145-0438	26
110-0904	5	122-0320	13	142-0282	17	145-0438	38
110-1807	5	122-0321	13	142-0282	29	146-0142	37
110-1824	5	122-0347	13	142-0334	17	146-0209	37

Numerical Index

Part No.	Page	Part No.	Page	Part No.	Page	Part No.	Page
146-0220	37	150-1187	7	155-1570	48	168-0183	5
146-0222	37	150-1214	10	155-1692	48	190-0171	31
146-0238	37	150-1214	25	155-1693	48	190-0266 ^{NS}	47
146-0247	37	150-1214	34	155-1697	48	190-0267	9
146-0259	37	150-1269	24	155-1703	48	190-0288	31
146-0261	37	150-1269	25	155-1704	48	190-0289	31
146-0262	37	150-1345	25	155-1722	48	190-0546	9
146-0281	37	150-1350	10	155-1723	48	190-0577	9
146-0282	37	150-1366	24	155-1848	48	190-0687	9
146-0289	37	150-1367	24	159-0020	32	191-0933	20
146-0292	37	150-1368	24	159-0595	32	191-1036	20
146-0311	37	150-1369	24	159-0596	32	191-1037	20
146-0322	38	150-1398	25	159-0597	32	191-1037	36
146-0324	38	150-1433	10	159-0981	32	191-1038	20
146-0325	38	150-1470	7	159-1150 ^{NS}	47	191-1038 ^{F-3}	36
146-0326	38	150-1519	8	160-0749	43	191-1039	20
146-0327	38	150-1520	8	160-1148	41	191-1040	20
146-0329	38	150-1544 ^{F-3}	33	160-1149	41	191-1041	20
146-0331	38	150-1576	25	160-1150	18	191-1048 ^{F-3}	20
146-0334	38	150-1725	25	160-1150	19	191-1154	36
146-0335	38	150-1749	34	160-1150	41	191-1155 ^{NS}	36
146-0337	38	152-0041	33	160-1151	18	191-1156	36
146-0340	38	152-0041	34	160-1151	41	191-1157	36
146-0341	38	152-0155	24	160-1154	41	191-1205	36
146-0342 ^{F-3}	38	152-0155	25	160-1158	41	191-1206	23
146-0343	38	152-0155	40	160-1161	41	191-1210	47
146-0356	38	152-0177	34	160-1183	19	191-1222	36
146-0377	38	152-0198	33	160-1219	19	191-1256	23
146-0379	17	152-0224	34	160-1285	19	191-1276	22
146-0379	29	153-0097	33	160-1301	9	191-1359	20
146-0380	17	153-0097	34	160-1303	18	191-1359	36
146-0380	29	153-0500	40	160-1303	19	191-1748	22
146-0381	38	153-0501	40	160-1305	43	192-0398	9
149-1299	5	153-0502	40	160-1306	43	193-0005	33
149-1299	7	153-0514	40	160-1307	9	193-0005	34
149-1299	26	153-0523	40	160-1311	19	193-0108	47
149-1321	7	153-0524	40	166-0554	18	301-4041	33
149-1321	15	154-0733	37	166-0604	18	301-5065	34
149-1321	26	154-0733	38	166-0614	18	301-5936	42
149-1982	26	154-1669	48	166-0772	18	302-0060	33
149-1982	30	154-1725	48	167-0188	22	302-0060	34
149-1983	29	154-1744	15	167-0188	23	307-1031	20
149-2005	39	154-1958	48	167-0188	43	307-1031	36
150-0075	8	154-1986 ^{NS}	48	167-0298	18	308-0385	33
150-0078	8	154-2128	48	167-0298	43	308-0385	34
150-0096	33	154-2129	48	167-1595	43	308-0490	33
150-0098	33	154-2666	15	167-1602	18	308-0490	34
150-0621	33	155-1256	48	168-0140	5	309-0237	47
150-0621	34	155-1257	48	168-0153	5	309-0510	47
150-0694	10	155-1381 ^{F-3}	48	168-0182	5	312-0069	41

Numerical Index

Part No.	Page	Part No.	Page	Part No.	Page	Part No.	Page
312-0246	19	503-0311	18	518-0176	24	800-0545	7
323-0853	23	503-0664	26	518-0176	25	801-0047	35
323-0890	F-3 23	503-0707	15	518-0311	6	801-0050	13
323-0892	F-3 23	503-0707	26	518-0328	15	802-0022	19
323-1085	23	503-0707	39	520-0738	31	802-0024	18
323-1257	22	503-0731	15	520-0739	31	802-0034	19
323-1257	23	503-0731	26	526-0006	24	802-0034	41
332-0152	47	503-0731	39	526-0006	25	803-0071	5
332-0325	33	504-0013	32	526-0008	19	812-0081	42
332-0537	42	505-0056	13	526-0015	33	812-0099	40
332-0941	15	505-0057	13	526-0015	34	812-0100	40
332-0942	33	505-0057	32	526-0015	43	813-0106	44
332-1279	47	505-0057	35	526-0016	33	813-0108	32
332-1408	33	505-0755	48	526-0016	34	815-0046	7
332-1408	47	505-0775	48	526-0017	9	815-0104	24
332-1993	33	505-0937	13	526-0018	5	815-0104	25
332-2208	42	508-0095	43	526-0021	11	815-0104	40
332-2319	22	508-0184	35	526-0021	24	815-0181	24
332-2319	23	509-0008	7	526-0021	25	815-0181	34
332-2423	22	509-0040	7	526-0063	5	815-0194	13
332-2423	23	509-0041	5	526-0065	7	815-0194	33
334-0028	42	509-0065	19	526-0065	13	815-0199	33
336-2378	18	509-0142	13	526-0065	35	815-0199	34
336-2378	19	509-0145	44	526-0066	13	815-0259	43
336-2378	41	509-0168	5	526-0066	35	815-0261	11
336-4385	42	510-0014	7	526-0108	40	815-0290	11
336-8466	μ 43	510-0015	8	526-0122	5	815-0358	19
338-1219	34	510-0105	7	526-0140	40	815-0358	41
403-1021	47	515-0001	8	526-0184	43	815-0359	40
403-1490	μ 47	515-0001	9	541-0222	9	815-0378	47
501-0004	33	515-0007	9	800-0003	15	815-0400	9
501-0008	32	515-0041	31	800-0004	24	815-0403	41
501-0009	34	515-0103	9	800-0005	33	815-0405	41
502-0005	34	515-0146	47	800-0005	34	815-0436	25
502-0017	33	515-0198	9	800-0007	13	815-0439	24
502-0020	32	515-0227	9	800-0010	5	815-0463	15
502-0020	33	516-0059	24	800-0023	15	815-0470	22
502-0020	47	516-0059	25	800-0023	26	815-0475	μ-10 25
502-0051	34	516-0059	40	800-0026	48	815-0480	40
502-0053	47	516-0072	5	800-0028	13	815-0555	26
502-0065	34	516-0130	7	800-0030	35	815-0570	20
502-0175	47	516-0141	5	800-0031	35	815-0570	36
502-0580	35	517-0009	34	800-0032	7	815-0593	23
502-0581	35	517-0048	5	800-0032	47	821-0007	22
503-0107	44	517-0067	5	800-0033	15	821-0007	23
503-0171	44	517-0120	5	800-0034	47	821-0009	33
503-0274	44	517-0129	11	800-0051	5	821-0010	10
503-0301	7	517-0151	44	800-0056	13	821-0010	34
503-0301	15	518-0004	10	800-0075	31	821-0014	9
503-0301	26	518-0014	9	800-0540	5	821-0016	9

Numerical Index

Part No.	Page	Part No.	Page	Part No.	Page	Part No.	Page
850-0025	41						
850-0030	40						
850-0030	44						
850-0038	18						
850-0038	41						
850-0040	13						
850-0040	15						
850-0040	19						
850-0040	20						
850-0040	24						
850-0040	26						
850-0040	36						
850-0045	15						
850-0045	47						
850-0045	48						
850-0050	5						
850-0050	13						
850-0050	31						
850-0055	9						
850-0055	31						
850-2005	18						
853-0005	42						
853-0013	15						
854-0010	40						
860-0008	42						
862-0001	15						
862-0001	24						
865-0020	15						
870-0053	32						
870-0065	33						
870-0065	34						
870-0131	10						
870-0131	33						
870-0131	34						
870-0221	41						
870-0257	15						
870-0278	10						
870-0302	6						

HARDWARE IDENTIFICATION

Illustrated hardware items are only for identification purposes. All hardware items listed throughout this catalog are steel SAE grade five (5) or lower (zinc plated with clear chromate dip) unless parts description indicates differently. All dimensions are in inches.

WASHER TYPES

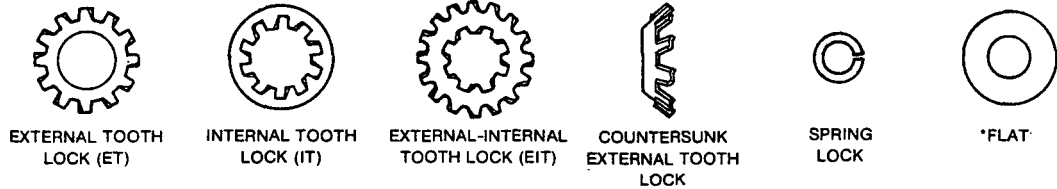

* - Flat washer dimensions given are: Inside Diameter (ID), Outside Diameter (OD) and Thickness (Thk).

BOLT AND SCREW TYPES

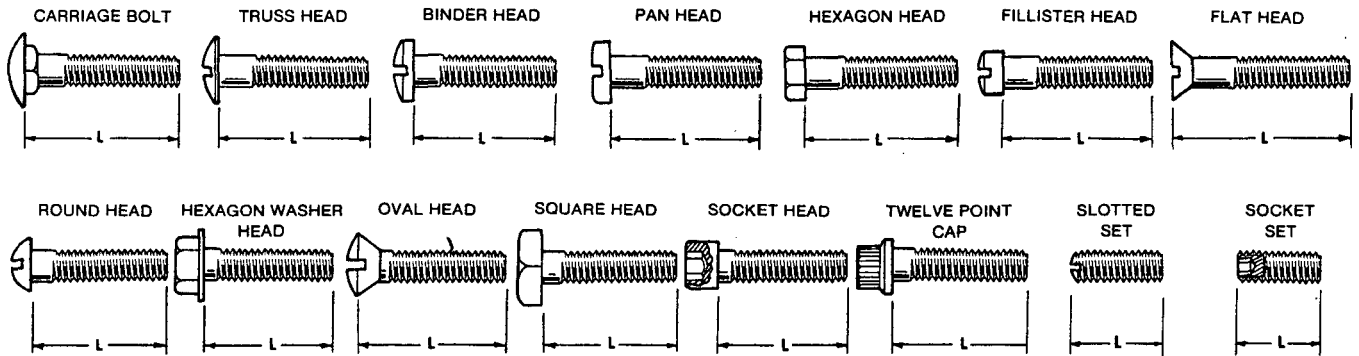

L - Measure length between these points.

INTERNAL DRIVE TYPES

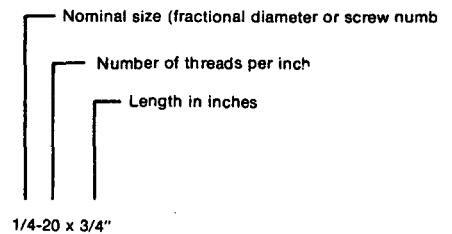
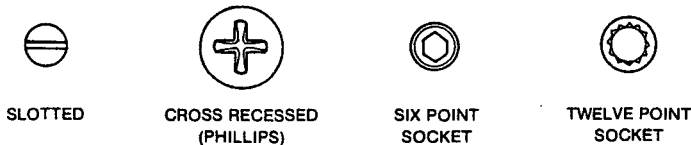

NUT TYPES

