

# BRIGGS & STRATTON

*4 Cycle Air-Cooled Engine*

## REPAIRMAN'S

## HANDBOOK

PRICE ONE DOLLAR



**BRIGGS & STRATTON CORP.**

MILWAUKEE 7, WIS.

## FOREWORD

Before attempting an engine overhaul or a tune-up, it is necessary that your shop be equipped with proper tools, equipment and mechanics who are thoroughly familiar with Briggs & Stratton engine design and construction. With your shop thus equipped, this book will serve as a guide in performing the various steps necessary to do a complete and satisfactory job.

In order to keep all tables as simple as possible, only the basic engine models are listed unless there is a difference between them and special models. You will find such special models listed separately in alphabetical order. Also, watch for difference between 5 and 6 digit type numbers of the same models.

To make inspection of parts simple and accurate only the sizes at which they should be rejected are shown. This eliminates the necessity for figuring allowances for wear, etc. If a part is worn larger (inside dimension such as magneto bearing) or smaller (such as crankshaft bearing surfaces) than the given sizes, they should be rejected and replaced with new parts.

Always use plug gauges wherever possible to eliminate doubt and possible mistakes. You will find plug gauges illustrated in Chapter 12. You will notice that most plug gauges have three sizes—A, B and C. The C end is used to check the old part and if it enters, the part is either out of round or oversize and should be rejected. The A and B ends are used to check the new parts after installation. A should enter, but B should not. Special repair parts, valve guides, valve seat inserts, contact point plunger bushing, etc., are not listed in the regular Parts Lists and part numbers will be found only in this book.

The term "Inspect," "Check," "Test" and "Replace" are used as follows:

**INSPECT**—Visual inspection, look for signs of wear, scoring, cracks, stripped threads, etc.

**CHECK**—Measure by means of plug gauges, feeler gauges, micrometer, scale, etc.

**TEST**—Analyze with proper testing equipment.

**REPLACE**—This usually means to take off the old part and reassemble it or replace with a new one.

# CONTENTS

(See Page 87 for Index)

|   | Page     |  | Page     |
|---|----------|--|----------|
| Foreword .....  | 2        | CHAPTER 6—Crankshaft, Cam Gears.....         | 54 to 57 |
| General Information .....                                     | 4        | Crankshaft Rejection Sizes—Table 18.....     | 54       |
| Model Data—Table 1 .....                                      | 5        | Removing Cam Gear .....                      | 55       |
| CHAPTER 1—Overhaul & Tune-up .....                            | 6 to 14  | Checking Crankshaft & Cam Gear.....          | 55       |
| Overhaul & Tune-up Procedure—Table 2.....                     | 6 to 9   | Replacing Cam Gear & Crankshaft .....        | 55       |
| Tune-up Data—Table 3.....                                     | 10       | Checking Crankshaft End Play .....           | 56       |
| Engine Speed Settings, Special Types .....                    | 11-12    | Correcting End Play .....                    | 57       |
| Engine Speed Settings, Standard .....                         | 13-14    | Correcting Warped Magneto Plates .....       | 57       |
| CHAPTER 2—Ignition .....                                      | 15 to 26 | CHAPTER 7—Cylinders .....                    | 58-59    |
| Spark Plug .....  | 15-16    | Inspection .....                             | 58       |
| Breaker Point Gap .....                                       | 16       | Bore Dimensions—Table 19 .....               | 58       |
| Condenser .....   | 16       | Resizing .....                               | 58       |
| Blower Housing .....  | 16       | Welding .....                                | 59       |
| Flywheel .....  | 16-17    | CHAPTER 8—Bearings .....                     | 60 to 65 |
| Ignition Cable .....  | 18       | Main Bearings .....                          | 60       |
| Magnetos .....  | 18 to 26 | Main Bearing Sizes—Table 21.....             | 61       |
| Magnetizing Flywheel & Rotors .....                           | 26       | Tools for Reaming .....                      | 60       |
| CHAPTER 3—Carburetion .....                                   | 27 to 40 | Magneto Bearings .....                       | 61       |
| Air Cleaners .....  | 27       | Drive Bearings .....                         | 62       |
| Fuel Supply System .....                                      | 27-28    | Reaming .....                                | 62-63    |
| Carburetors, Gravity Feed .....                               | 28-30    | Bearing Oil Retainer .....                   | 63-64    |
| Carburetors, Suction Feed .....                               | 30-31    | Ball Bearings .....                          | 64       |
| Automatic Choke, Adjusting .....                              | 31       | Cam Gear Bearings.....                       | 65       |
| Fuel Pump Diaphragm, Replacing .....                          | 31-32    | CHAPTER 9—Oil Systems.....                   | 66 to 71 |
| Remote Governor & Throttle Controls .....                     | 34       | Guide—Table 22 .....                         | 66       |
| Carburetor & Governor Controls .....                          | 35-40    | Repair Instructions by Models .....          | 67 to 71 |
| CHAPTER 4—Compression .....                                   | 41-49    | CHAPTER 10—Starters .....                    | 72 to 74 |
| Cylinder Heads .....  | 41       | Adjusting & Assembling .....                 | 72-74    |
| Valve Tapper Clearances—Table 6 .....                         | 41       | Retrievable Starters .....                   | 74       |
| Valve Springs .....   | 41-44    | CHAPTER 11—Special Information .....         | 75 to 81 |
| Adjusting Valve Tapper Clearance.....                         | 41       | Pumping Oil .....                            | 75       |
| Valve Seat Widths—Table 7.....                                | 44       | Power Lost when Hot .....                    | 75       |
| Removing Valve Guides .....                                   | 45       | Assembling Cap Screws to Aluminum Parts..... | 75       |
| Valve Guide Inspection Tools—Table 8.....                     | 45       | Warped Magneto Plate .....                   | 75       |
| Valve Guide Inspection Tools—Table 9.....                     | 45       | Oil Leaks .....                              | 75       |
| Valve Guide Numbers—Table 10.....                             | 45       | Removing Rusted Flywheel .....               | 76       |
| Installing Valve Guides .....                                 | 46       | Gear Reduction Assemblies .....              | 76 to 78 |
| Valve Seats .....   | 46 to 48 | End Play Gear Reduction Drive Shafts.....    | 78       |
| Tools for installing Valve Seat Insert.....                   | 48       | Model WMG Generator .....                    | 79       |
| Valves, Timing .....  | 48-49    | Oil Return Valves .....                      | 79       |
| CHAPTER 5—Piston, Piston Pins, Connecting<br>Rods .....       | 50 to 53 | Breathers .....                              | 79-80    |
| Checking Rings .....  | 50       | Change Oil System (Model WM-WMG-PCWM) .....  | 80       |
| Checking Piston .....   | 50       | Change Oil Pump (Model I-IBP-WI-WMI).....    | 81       |
| Connecting Rod & Piston Pin Rejection<br>Sizes—Table 15 ..... | 51       | CHAPTER 12—Tools .....                       | 82 to 86 |
| Checking Piston Pin .....                                     | 51       | Major Tool List—Table 24.....                | 82 to 85 |
| Checking Connecting Rod .....                                 | 51       | Mounting Board .....                         | 86       |
| Aligning Rod & Piston .....                                   | 51       |  |          |
| Rod Aligning Plugs—Table 16.....                              | 52       |  |          |
| Assembling Rings to Piston .....                              | 52       |  |          |
| Installing Piston & Rod in Cylinder.....                      | 53       |  |          |
| Connecting Rod Cap Screw Torque .....                         | 53       |  |          |

## GENERAL INFORMATION AND RECOMMENDATIONS

Briggs & Stratton engines are of the same basic 4 stroke cycle design used in automobiles, aircraft, trucks and tractors. As the name indicates, there are four strokes to one complete power cycle:

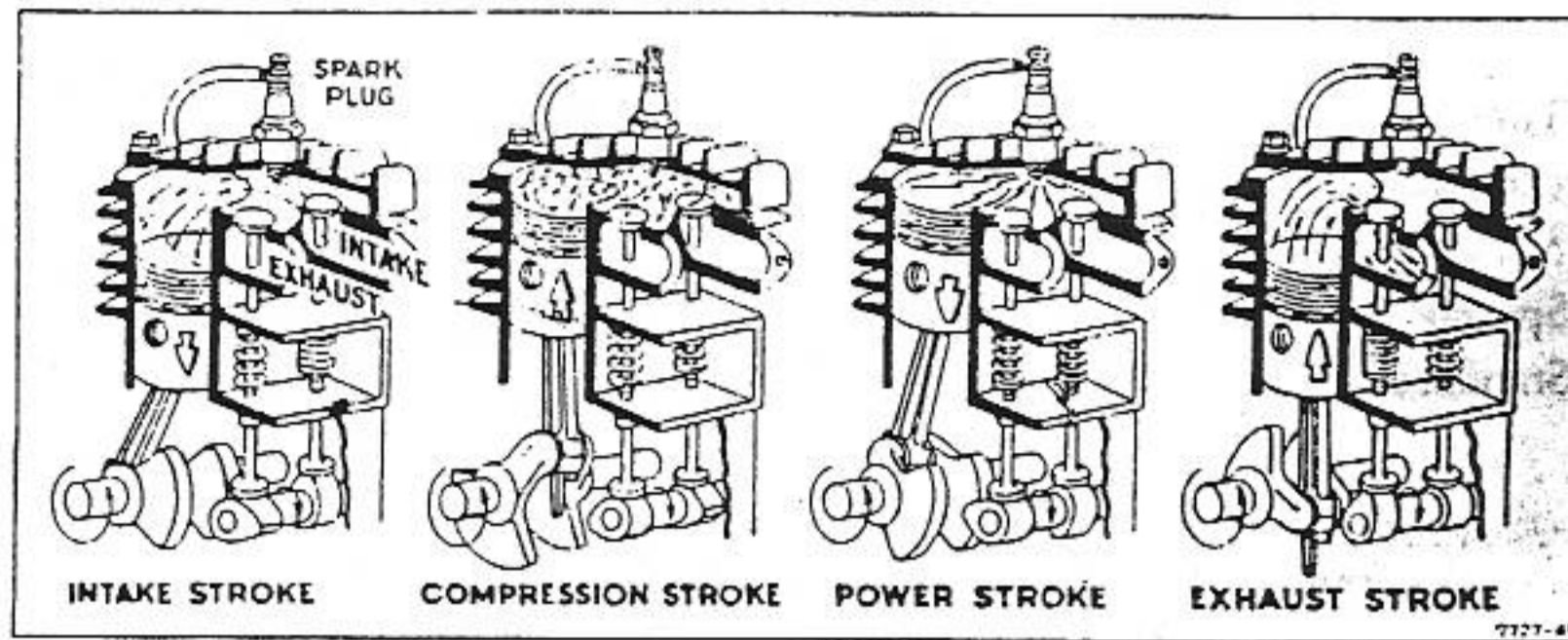


Fig. 1—THE 4-STROKE CYCLE

- a. **INTAKE STROKE:** The piston goes down, creating a vacuum in the cylinder which draws gas through open intake valve into the space above piston.
- b. **COMPRESSION STROKE:** The piston comes up with both valves closed, highly compressing the gas into the space left between the top of the piston and cylinder head.
- c. **POWER STROKE:** At this point the magneto sends high tension current to the spark plug, firing or exploding the compressed gas and driving the piston down.
- d. **EXHAUST STROKE:** Exhaust valve opens and the upward stroke of the piston forces out all of the burnt gases, thus completing the power cycle.

### USE CLEAN GASOLINE

A good, clean, fresh, regular gasoline is recommended. A gasoline of too high test may form a vaporlock in the fuel line when engine gets hot. This interrupts the flow of gasoline and causes the engine to stop.

The use of highly leaded gasoline also is to be avoided as it causes deposits on valve seats, spark plug points and in the cylinder head, thereby shortening engine life.

### CORRECT LUBRICATION IS IMPORTANT

We recommend the use of Mobiloil "Arctic" or other high grade oil having a low carbon residue and a body not heavier than S.A.E. No. 20 for operating the engine in temperatures of 32° and above. For temperatures below 32°, use Mobiloil "Arctic Special" or other high grade oil not heavier than S.A.E. No. 10 W. Oil base should be filled to the top of the filler plug after each 5 hours of engine operation.

**OIL SHOULD BE CHANGED AFTER EACH 25 HOURS OF ENGINE OPERATION.** In normal running of any engine, small particles of metal from the cylinder walls, pistons and bearings will gradually work into the oil. Dust particles from the air also get into the oil. If the oil is not changed regularly, these foreign particles cause increased friction and a grinding action which shorten the life of the engine. Fresh oil also assists in cooling, for old oil gradually becomes thick and loses its cooling effect as well as its lubricating qualities.

Oil in the air cleaner should be changed every 25 hours of engine operation. Refill with clean oil to the oil level mark. Dirty operating conditions require more frequent changes. Under extreme conditions, oil should be changed hourly.

### CAUTION!

Exhaust gases contain carbon monoxide which is odorless and a deadly poison. Proper care must be taken to provide efficient ventilation when running an engine indoors.

Fill the crankcase and air cleaner with proper oil before starting engine. See that oil level is maintained.

Do not fill the gasoline tank while the engine is running. Avoid spilling gasoline on a hot engine—this may cause an explosion and serious injury.

## MODEL DATA

Each Briggs & Stratton engine carries a basic Model Letter or Number, such A, B, ZZ, 5, 14, 23, etc. This will be found stamped on the metal nameplate. Engines having special features are identified by additional letter or numerals affixed to the basic model letter or number such as AP, AR-6, 14FB, etc. For example: Model AR-6 is a model A engine with a 6-to-1 gear reduction, 6H is a horizontal Model 6.

Use the same parts and method of repair as for the basic model, except where special instructions or parts are mentioned. The following lists explain the letter symbols used:

### EXPLANATION OF LETTERS FOLLOWING BASIC MODEL LETTERS

G—Generator  
H—High Speed  
L—Aluminum  
P—Direct Crankcase Mounting  
R—Reduction Gear  
M—Marine Conversion  
S—Suction Carburetor  
T—Marine Transmission

### EXPLANATION OF LETTERS FOLLOWING BASIC MODEL NUMBER

B—Ball Bearing  
C—Automatic Choke  
D—Power Takeoff  
    Revolves Clockwise  
F—Flange Mounting  
H—Horizontal  
P—Fuel Pump  
R—Reduction Gear  
S—Suction Carburetor

TABLE I - COMPLETE LIST OF BASIC AND SPECIAL ENGINE MODELS

| BASIC MODELS | CORRESPONDING SPECIAL MODELS  | BASIC MODELS | CORRESPONDING SPECIAL MODELS   |
|--------------|---|--------------|--|
| A            | AGR-4, AH, AHL, AHLP, AHP, AHM, AHMT, AHR-4, AHR-6, AL, ALP, ALR-4, ALR-6, AP, AM, AMT, AR-4, AR-6    | S            | SC   |
| B            | BH, BHL, BHLP, BHP, BHM, BHR-4, BHR-6, BHLR-4, BHLR-6, BL, BLP, BLR-4, BLR-6, BM, BMG, BP, BR-4, BR-6 | T            | TA   |
| FH           | FHI   | U            | UR-2, UR-6   |
| FI           |   | W            | WA   |
| FJ           | FJ1, FJ2  | WI           | WIBP, WR-6, WIPRI.6, WIPR6   |
| H            | HM  | WM           | WMG  |
| I            | IB, IBHP, IBLP, IBP, IL, ILR-6, IMT, IP, IR-6, IS, IPRI.6, IPR6                                       | WMB          | WBG  |
| K            | KL, KLP, KLR-4, KLR-6, KM, KP, KR-4, KR-6   | WMI          | WMIP   |
| L            | LA  | Y            |  |
| M            | MC, MB, MF, MH  | Z            | ZH, ZHL, ZHLP, ZHP, ZHLR-4, ZHLR-6, ZHM, ZHR-4, ZHR-6, ZL, ZLP, ZLR-4, ZLR-6, ZM, ZP, ZR-4, ZR-6 |
| N            | NP, NR-2, NR-6, NPRI.6, NPR6  | ZZ           | ZZL, ZZLP, ZZP, ZZR  |
| NS           | NSPRI.6, NSPR6  | 5            | 5S   |
| PB           |   | 6            | 6H, 6HF, 6HFB, 6HS, 6HSF, 6S   |
| Q            |   | 8            | 8FB, 8HF, 8R4D, 8R6  |
| R            | RC  | 9            | 9B, 9FB, 9FBC, 9FBP, 9P, 9R6, 9R6D   |
|              |   | 14           | 14B, 14F, 14FB, 14FBC, 14FBPC, 14FBP, 14P, 14R6, 14R6D   |
|              |   | 23           | 23B, 23FB, 23FBP, 23FBPC, 23P, 23PC, 23R6, 23R6D   |

TABLE 2 - OVERHAUL AND TUNE-UP PROCEDURE

We recommend that the following procedure be followed in overhauling all Briggs & Stratton engines. It is possible, of course, that these operations be performed in different sequence but we believe that performing the steps in the same order every time increases efficiency. All steps may not be necessary on every engine. The condition of the engine will determine what should be done. However, the steps listed in the Tune Up (see page ) should be performed in every case. The operations listed apply to models indicated by an "x".

| The words, remove and inspect or reassemble, should be understood in each step unless another operation such as check, test or adjust is indicated. |   | MODEL  |               |    |   |        |          |   |
|---|---|--------|---------------|----|---|--------|----------|---|
|   |   | N<br>8 | 9<br>14<br>23 | ZZ | B | 5<br>6 | NS<br>WI | A |
| <b>DISASSEMBLY</b>  |   |        |               |    |   |        |          |   |
| 1.  | Air Cleaner   | x      | x             | x  | x | x      | x        | x |
| 2.  | Muffler (Remove only when necessary)  | x      | x             | x  | x | x      | x        | x |
| 3.  | Fuel Pipe   | x      | x             | x  | x |        | x        | x |
| 4.  | Fuel filter yoke-bowl-gasket-screen only  | x      | x             | x  | x |        |          | x |
| 5.  | Tank outlet assembly  |        |               |    |   |        | x        |   |
| 6.  | Air cleaner elbow or pipe   | x      | x             | x  | x |        |          | x |
| 7.  | Carburetor and linkage  | x      | x             | x  | x | x      | x        | x |
| 8.  | Check space between upper and lower bodies<br>Check throttle shaft and bushing for wear | x      | x             | x  | x |        |          | x |
| 9.  | Disassemble carburetor  | x      | x             | x  | x |        |          | x |
| 10.   | Spin flywheel to check compression  | x      | x             | x  | x | x      | x        | x |
| 11.   | Spark plug. Adjust gap, clean, test<br>(Gap .025)                                       | x      | x             | x  | x | x      | x        | x |
| 12.   | Carburetor intake elbow   | x      | x             | x  | x |        |          | x |
| 13.   | Fuel tank. Remove from tank bracket only<br>when tank is to be replaced                 | x      | x             | x  | x | x      | x        | x |
| 14.   | Rope starter pulley   |        | x             | x  | x |        |          | x |
| 15.   | Blower housing  | x      | x             | x  | x | x      | x        | x |
| 16.   | Check air gap, armature to flywheel   | x      |               |    |   | x      | x        |   |
| 17.   | Valve cover   | x      | x             | x  | x | x      | x        | x |
| 18.   | Breather (Cover, strainer and moss only<br>on 9-14-23-A-B-ZZ)                           | x      | x             | x  | x | x      | x        | x |
| 19.   | Cylinder head and shield  | x      | x             | x  | x | x      | x        | x |
| 20.   | Check tappet clearance  | x      | x             | x  | x | x      | x        | x |
| 21.   | Rope starter pulley   | x      |               |    |   | x      | x        |   |
| 22.   | Flywheel  | x      | x             | x  | x | x      | x        | x |
| 23.   | Breaker point cover   | x      | x             | x  | x | x      | x        | x |
| 24.   | Check breaker point gap. (Gap .020) For<br>replacement of points see step 67 & 73).     | x      | x             | x  | x | x      | x        | x |
| 25.   | Check point plunger hole. To rebush see<br>step 63.                                     | x      |               | x  | x | x      | x        | x |
| 26.   | Breaker box   |        | x             |    |   |        |          |   |
| 27.   | Drain oil   | x      | x             | x  | x | x      | x        | x |
| 28.   | Base  | x      | x             | x  | x | x      | x        | x |
| 29.   | Mechanical governor parts   | x      | x             | x  | x |        |          | x |
| 30.   | Connecting rod and piston from engine   | x      | x             | x  | x | x      | x        | x |
| 31.   | Check end play  | x      | x             | x  | x | x      | x        | x |
| 32.   | Test condenser. (To replace see step 66<br>or 72)                                       | x      | x             | x  | x | x      | x        | x |
| 33.   | Rotor   |        | x             |    |   |        |          |   |
| 34.   | Test coil. (To replace see step 75)   |        | x             |    |   |        |          |   |
| 35.   | Test armature. (To replace see step 64)   | x      |               | x  | x | x      | x        | x |
| 36.   | Coil and armature assembly  |        | x             |    |   |        |          |   |
| 37.   | Back plate  |        | x             | x  | x |        |          |   |
| 38.   | Governor blade. (To replace see step 65)  | x      |               |    |   | x      | x        |   |

TABLE 2 - OVERHAUL AND TUNE-UP PROCEDURE (CONT'D)

| The words, remove and inspect or reassemble, should be understood in each step unless another operation such as check, test or adjust is indicated. |  | MODEL  |               |    |   |        |          |   |
|---|--|--------|---------------|----|---|--------|----------|---|
|   |  | N<br>8 | 9<br>14<br>23 | ZZ | B | 5<br>6 | NS<br>WI | A |
| 39.   | Magneto. Check bearing with plug gauge   | x      |               | x  | x | x      | x        | x |
| 40.   | Bearing support. First remove burr at set screw hole and keyway on 9-14-23. Check bearing with plug gauge. |        | x             |    |   |        |          |   |
| 41.   | Crankcase cover  |        | x             | x  | x |        |          |   |
| 42.   | *Crankshaft  | x      | x             | x  | x | x      | x        | x |
| 43.   | Check crankshaft. (Crankpin, journals, power take-off)   | x      | x             | x  | x | x      | x        | x |
| 44.   | Valves and springs   | x      | x             | x  | x | x      | x        | x |
| 45.   | Cam shaft and gear   | x      | x             | x  | x | x      | x        | x |
| 46.   | Check automatic spark advance  |        | x             |    |   |        |          |   |
| 47.   | Tappets  | x      | x             | x  | x | x      | x        | x |
| 48.   | Cylinder. Check bore, bearing, valve guides and seats  | x      | x             | x  | x | x      | x        | x |
| 49.   | Cylinder from crankcase  |        |               | x  |   |        |          |   |
| 50.   | Disassemble connecting rod and piston  | x      | x             | x  | x | x      | x        | x |
| 51.   | Check piston, rings, conn. rod, piston pin   | x      | x             | x  | x | x      | x        | x |
| <b>REPAIRS</b>  |  |        |               |    |   |        |          |   |
| 52.   | Clean parts  | x      | x             | x  | x | x      | x        | x |
| <b>CYLINDER</b>   |  |        |               |    |   |        |          |   |
| 53.   | Hone cylinder bore to next oversize  | x      | x             | x  | x | x      | x        | x |
| 54.   | Replace valve guide (intake or exhaust)  | x      | x             | x  | x | x      | x        | x |
| 55.   | Install valve guide (intake or exhaust)  | x      |               |    |   | x      | x        |   |
| 56.   | Reface valve and seat and lap. (One only, intake or exhaust - double for both)                             | x      | x             | x  | x | x      | x        | x |
| 57.   | Replace exhaust valve seat insert  | x      | x             | x  | x | x      | x        | x |
| 58.   | Install intake valve seat insert   | x      | x             | x  | x | x      | x        | x |
| 59.   | Replace cylinder bushing   | x      |               |    | x | x      | x        | x |
| 60.   | Replace oil seal   | x      | x             | x  | x | x      | x        | x |
| 61.   | Replace breather body  |        | x             | x  | x |        |          | x |
| <b>MAGNETO</b>  |  |        |               |    |   |        |          |   |
| 62.   | Replace magneto bushing and oil seal   | x      |               | x  | x | x      | x        | x |
| 63.   | Install breaker point plunger bushing  | x      |               | x  | x | x      | x        | x |
| 64.   | Replace armature and governor blade  | x      |               | x  | x | x      | x        | x |
| 65.   | Replace governor blade   | x      |               |    |   | x      | x        |   |
| 66.   | Replace condenser  | x      |               | x  | x | x      | x        | x |
| 67.   | Replace breaker points   | x      |               | x  | x | x      | x        | x |
| 68.   | Replace ignition cable   | x      |               | x  | x | x      | x        | x |
| <b>CARBURETOR</b>   |  |        |               |    |   |        |          |   |
| 69.   | Replace throttle shaft bushings  | x      | x             | x  | x |        |          | x |
| 70.   | Reassemble carburetor  | x      | x             | x  | x |        |          | x |
| <b>BREAKER BOX</b>  |  |        |               |    |   |        |          |   |
| 71.   | Replace breaker shaft  |        | x             |    |   |        |          |   |
| 72.   | Replace condenser  |        | x             |    |   |        |          |   |
| 73.   | Replace breaker points   |        | x             |    |   |        |          |   |
| 74.   | Replace primary lead wire  |        | x             |    |   |        |          |   |
| * On models AP-1-NP-BFB remove cam shaft and push cam gear into cylinder pocket before removing crankshaft.   |  |        |               |    |   |        |          |   |

TABLE 2 - OVERHAUL AND TUNE-UP PROCEDURE (CONT'D)

| The words, remove and inspect or reassemble, should be understood in each step unless another operation such as check, test or adjust is indicated. |   | MODEL  |               |    |   |        |          |   |
|---|---|--------|---------------|----|---|--------|----------|---|
|   |   | N<br>8 | 9<br>14<br>23 | ZZ | B | 5<br>6 | NS<br>WI | A |
| <b>COIL AND ARMATURE ASSEMBLY</b>   |   |        |               |    |   |        |          |   |
| 75.   | Replace coil or armature or both  |        | x             |    |   |        |          |   |
| <b>CAM GEAR</b>   |   |        |               |    |   |        |          |   |
| 76.   | Replace automatic spark advance weight and spring                                 |        | x             |    |   |        |          |   |
| <b>REASSEMBLY</b>   |   |        |               |    |   |        |          |   |
| Reassemble the parts and make proper adjustment in the following sequence.  |   |        |               |    |   |        |          |   |
| 77.   | Cylinder to crankcase   |        |               | x  |   |        |          |   |
| 78.   | Tappets   | x      | x             | x  | x | x      | x        | x |
| 79.   | *Cam gear, cam shaft and plug   | x      | x             | x  | x | x      | x        | x |
| 80.   | Crankshaft and bearing support or magneto with breaker plunger                    | x      | x             | x  | x | x      | x        | x |
| 81.   | Crankcase cover   |        | x             | x  | x |        |          |   |
| 82.   | Adjust end play with gaskets  | x      | x             | x  | x | x      | x        | x |
| 83.   | Breaker box assembly  |        | x             |    |   |        |          |   |
| 84.   | Breaker point gap. Clean and adjust   | x      | x             | x  | x | x      | x        | x |
| 85.   | Piston, piston pin, conn. rod. Align.   | x      | x             | x  | x | x      | x        | x |
| 86.   | Rings   | x      | x             | x  | x | x      | x        | x |
| 87.   | Install piston and connecting rod in cylinder and spin crankshaft                 | x      | x             | x  | x | x      | x        | x |
| 88.   | Mechanical governor parts   | x      | x             | x  | x |        |          | x |
| 89.   | Base  |        | x             | x  | x |        |          | x |
| 90.   | Base with 2 mounting screws   | x      |               |    |   | x      | x        |   |
| 91.   | Base with 8 mounting screws   | x      |               |    |   |        | x        |   |
| 92.   | Rotor   |        | x             |    |   |        |          |   |
| 93.   | Back plate  |        | x             | x  | x |        |          |   |
| 94.   | Coil and armature assembly  |        | x             |    |   |        |          |   |
| 95.   | Check rotor timing  |        | x             |    |   |        |          |   |
| 96.   | Adjust rotor timing   |        | x             |    |   |        |          |   |
| 97.   | Breaker point cover   | x      | x             | x  | x | x      | x        | x |
| 98.   | Flywheel  | x      | x             | x  | x | x      | x        | x |
| 99.   | Rope starter pulley   | x      |               |    |   | x      | x        |   |
| 100.  | Adjust armature to flywheel air gap   | x      |               |    |   | x      | x        |   |
| 101.  | Check spark   | x      | x             | x  | x | x      | x        | x |
| 102.  | Adjust valve tappet clearance   | x      | x             | x  | x | x      | x        | x |
| 103.  | Valves, springs, retainers<br>Recheck tappet clearance                            | x      | x             | x  | x | x      | x        | x |
| 104.  | Intake elbow  | x      | x             | x  | x |        |          | x |
| 105.  | Cylinder head, cylinder shield, cylinder head cover                               | x      | x             | x  | x | x      | x        | x |
| 106.  | Recheck spark plug gap. Assemble plug with graphite on threads. Check compression | x      | x             | x  | x | x      | x        | x |
| 107.  | Breather  | x      | x             | x  | x | x      | x        | x |
| 108.  | Valve cover   | x      | x             | x  | x | x      | x        | x |
| 109.  | Carburetor and linkage  | x      | x             | x  | x | x      | x        | x |
| 110.  | Pneumatic governor. Check and align   | x      |               |    |   | x      | x        |   |
| 111.  | Mechanical governor. Check and adjust   |        | x             | x  | x |        |          | x |
| * On models AP-1-NP-8FB the crankshaft must be installed before cam shaft.  |   |        |               |    |   |        |          |   |

TABLE 2 - OVERHAUL AND TUNE-UP PROCEDURE (CONT'D)

| The words, remove and inspect or reassemble, should be understood in each step unless another operation such as check, test or adjust is indicated. |   | MODEL  |               |    |   |        |          |   |
|---|---|--------|---------------|----|---|--------|----------|---|
|   |   | N<br>8 | 9<br>14<br>23 | ZZ | B | 5<br>6 | NS<br>WI | A |
| <b>REASSEMBLY (Cont'd.)</b>   |   |        |               |    |   |        |          |   |
| 112.  | Blower housing                                | x      | x             | x  | x | x      | x        | x |
| 113.  | Rope starter pulley                           |        | x             | x  | x |        |          | x |
| 114.  | Fuel tank                                     | x      | x             | x  | x | x      | x        | x |
| 115.  | Fuel filter parts, screen, gasket, bowl, yoke | x      | x             | x  | x |        |          | x |
| 116.  | Outlet assembly                               |        |               |    |   |        | x        |   |
| 117.  | Fuel pipe                                     | x      | x             | x  | x |        | x        | x |
| 118.  | Air cleaner elbow or pipe                     | x      | x             | x  | x |        |          | x |
| 119.  | Muffler                                       | x      | x             | x  | x | x      | x        | x |
| 120.  | Fill crankcase with oil                       | x      | x             | x  | x | x      | x        | x |
| 121.  | Spray engine and assemble decals              | x      | x             | x  | x | x      | x        | x |
| 122.  | Start engine                                  | x      | x             | x  | x | x      | x        | x |
| 123.  | Check spark                                   | x      | x             | x  | x | x      | x        | x |
| 124.  | Retighten cylinder head screws                | x      | x             | x  | x | x      | x        | x |
| 125.  | Adjust carburetor                             | x      | x             | x  | x | x      | x        | x |
| 126.  | Set governor to correct engine speed          | x      | x             | x  | x | x      | x        | x |
| 127.  | Clean, fill, assemble air cleaner             | x      | x             | x  | x | x      | x        | x |

### TUNE UP PROCEDURE

The Tune Up consists only of the fifteen steps listed below which includes no repairs. These steps apply to all models except Step #2 which applies to Models N-8-9-14-23 only - Step #3 to Models NS-WI-WMB-5S-6S only and Step #6 to N-NS-WI-WMB-5S-6S-8 only.

1. Inspect air cleaner.
2. Clean fuel pipe, fuel filter and tank on gravity feed system.
3. Clean fuel pipe, outlet assembly and tank on suction feed system.
4. Rock flywheel to check compression.
5. Test spark plug, clean and regap.
6. Check and adjust governor blade.
7. Inspect breaker points and adjust to .020".
8. Inspect condenser and breaker point connections.
9. Reassemble parts except air cleaner.
10. Fill crankcase with oil
11. Start engine.
12. Check spark with tester No. MPJ-T7 while engine is running.
13. Adjust carburetor.
14. Set governor to correct engine speed.
15. Clean, refill and reassemble air cleaner.

TABLE 3 - TUNE-UP DATA

| ENGINE MODEL      | CHAMPION SPARK PLUG | AUTO LITE SPARK PLUG | VALVE CLEARANCE |      |         |      | CARBURETOR ADJUSTMENT |                |
|-------------------|---------------------|----------------------|-----------------|------|---------|------|-----------------------|----------------|
|                   |                     |                      | INTAKE          |      | EXHAUST |      | TURNS OPEN            |                |
|                   |                     |                      | MAX.            | MIN. | MAX.    | MIN. | IDLE VALVE            | NEEDLE VALVE   |
| A (5 Digit)       | 8 com *             | B7 *                 | .007            | .005 | .009    | .007 | 1/2 to 3/4            | 1 to 1 1/4     |
| A (6 Digit)       | 8 com *             | B7 *                 | .009            | .007 | .011    | .009 | 1/2 to 3/4            | 1 to 1 1/4     |
| A (TPA Ex Valve)  | 8 com *             | B7 *                 | .009            | .007 | .016    | .014 | 1/2 to 3/4            | 1 to 1 1/4     |
| B (5 Digit)       | 8 com *             | B7 *                 | .007            | .005 | .009    | .007 | 1/2 to 3/4            | 1 to 1 1/2     |
| B (6 Digit)       | 8 com *             | B7 *                 | .009            | .007 | .011    | .009 | 1/2 to 3/4            | 1 to 1 1/2     |
| B (TPA Ex Valve)  | 8 com *             | B7 *                 | .009            | .007 | .016    | .014 | 1/2 to 3/4            | 1 to 1 1/2     |
| FH                | 8 com *             | B7 *                 | 1/16            | 1/32 | .013    | .011 | None                  | 1 to 1 1/2     |
| FI                | 8 com *             | B7 *                 | .007            | .005 | .007    | .005 | None                  | 3/4 to 1       |
| FJ                | 8 com *             | B7 *                 | .011            | .009 | .021    | .019 | None                  | 1 to 1 1/4     |
| H                 | 8 com *             | B7 *                 | .011            | .009 | .021    | .019 | None                  | 1 to 1 1/4     |
| I-1BP             | J8                  | A7F                  | .009            | .007 | .016    | .014 | 1/2 to 3/4            | 1 to 1 1/4     |
| K                 | 8 com *             | B7 *                 | .007            | .005 | .015    | .013 | 1/2 to 3/4            | 1 to 1 1/2     |
| L                 | 8 com *             | B7 *                 | .011            | .009 | .021    | .019 | None                  | 1 to 1 1/2     |
| M                 | 8 com *             | B7 *                 | .007            | .005 | .009    | .007 | None                  | 1 to 1 1/4     |
| MB-MF             | 8 com *             | B7 *                 | .007            | .005 | .009    | .007 | 1/2 to 3/4            | 1 to 1 1/4     |
| N                 | J8                  | A7F                  | .009            | .007 | .016    | .014 | 1/2 to 3/4            | 1 to 1 1/4     |
| PE                | 8 com *             | B7 *                 | 3/32            | 1/16 | .021    | .019 | None                  | 3/4 to 1       |
| Q                 | 8 com *             | B7 *                 | .007            | .005 | .009    | .007 | None                  | 3/4 to 1       |
| R                 | 8 com *             | B7 *                 | .007            | .005 | .009    | .007 | 1/2 to 3/4            | 1 to 1 1/4     |
| S                 | 8 com *             | B7 *                 | .007            | .005 | .009    | .007 | None                  | 1 to 1 1/2     |
| T                 | 8 com *             | B7 *                 | .007            | .005 | .009    | .007 | None                  | 1 to 1 1/4     |
| U                 | J8                  | A7F                  | .007            | .005 | .016    | .014 | None                  | 1 1/4 to 1 1/2 |
| W                 | 8 com *             | B7 *                 | .007            | .005 | .009    | .007 | 1/2 to 3/4            | 1 to 1 1/4     |
| WI                | J8                  | A7F                  | .007            | .005 | .016    | .014 | None                  | 1 to 1 1/4     |
| WM                | J8                  | A7F                  | .007            | .005 | .016    | .014 | None                  | 1 to 1 1/4     |
| WMB               | J8                  | A7F                  | .007            | .005 | .016    | .014 | None                  | 1 to 1 1/4     |
| WMI               | J8                  | A7F                  | .007            | .005 | .016    | .014 | None                  | 1 to 1 1/4     |
| Y                 | 8 com *             | B7 *                 | .011            | .009 | .021    | .019 | None                  | 1 to 1 1/2     |
| Z                 | 8 com *             | B7 *                 | .009            | .007 | .016    | .014 | 1/2 to 3/4            | 1 to 1 1/4     |
| ZZ                | 8 com *             | B7 *                 | .021            | .019 | .019    | .017 | 1/2 to 3/4            | 1 to 1 1/2     |
| ZZ (TPA Ex Valve) | 8 com *             | B7 *                 | .021            | .019 | .023    | .021 | 1/2 to 3/4            | 1 to 1 1/2     |
| 5S                | J8                  | A7F                  | .009            | .007 | .016    | .014 | None                  | 1 to 1 1/2     |
| 6S-6HS-6HSF       | J8                  | A7F                  | .009            | .007 | .016    | .014 | None                  | 1 to 1 1/2     |
| 6H-6HF            | J8                  | A7F                  | .009            | .007 | .016    | .014 | 1/2 to 3/4            | 1 to 1 1/4     |
| 8-8H-8HF          | J8                  | A7F                  | .009            | .007 | .016    | .014 | 1/2 to 3/4            | 1 to 1 1/4     |
| 9                 | J8                  | A7F                  | .009            | .007 | .016    | .014 | 1/2 to 3/4            | 1 to 1 1/4     |
| 9 (TPA Ex Valve)  | J8                  | A7F                  | .009            | .007 | .019    | .017 | 1/2 to 3/4            | 1 to 1 1/4     |
| 14                | J8                  | A7F                  | .009            | .007 | .016    | .014 | 1/2 to 3/4            | 1 to 1 1/2     |
| 14 (TPA Ex Valve) | J8                  | A7F                  | .009            | .007 | .019    | .017 | 1/2 to 3/4            | 1 to 1 1/2     |
| 23                | J8                  | A7F                  | .009            | .007 | .019    | .017 | 1/2 to 3/4            | 1 to 1 1/2     |
| 23 (TPA Ex Valve) | J8                  | A7F                  | .009            | .007 | .023    | .021 | 1/2 to 3/4            | 1 to 1 1/2     |

\* Champion No. 5 or Autolite BT4A are recommended for continuous heavy use.

TABLE NO. 4 - ENGINE SPEED SETTINGS FOR SPECIAL TYPE NUMBERS

Before setting the engine speed, see if the type number is listed in this table. If type number is listed, set engine speed at RPM indicated. If type number is not listed see Table 5 for Standard Speed Setting. These speeds allow for a drop in RPM when the load is applied.

| TYPE NO. | RPM  | TYPE NO. | RPM  | TYPE NO. | RPM  | TYPE NO. | RPM  | TYPE NO. | RPM  | TYPE NO. | RPM  |
|----------|------|----------|------|----------|------|----------|------|----------|------|----------|------|
| 20005    | 2050 | 25463    | 2200 | 95566    | 2450 | 203035   | 2000 | 205657   | 2800 | 208058   | 2200 |
| 20015    | 2125 | 25465    | 2000 | 95581    | 2225 | 203040   | 2450 | 205659   | 2300 | 208059   | 2200 |
| 20018    | 2700 | 25567    | 2000 | 95583    | 2225 | 203041   | 1850 | 205663   | 2000 | 208064   | 2200 |
| 20025    | 1950 | 25604    | 2200 | 95608    | 1900 | 203043   | 2600 | 205675   | 2300 | 208065   | 2200 |
| 20058    | 1925 | 25605    | 2200 | 95834    | 2500 | 203314   | 3000 | 205676   | 2300 | 208066   | 2200 |
| 20080    | 2000 | 25606    | 1850 | 95853    | 2920 | 203518   | 2000 | 205678   | 2640 | 208068   | 2100 |
| 20081    | 2200 | 25607    | 2000 | 95910    | 3300 | 203521   | 2000 | 205683   | 2900 | 208069   | 2200 |
| 20082    | 2000 | 25608    | 2200 | 95919    | 2400 | 203527   | 3200 | 205754   | 2500 | 208070   | 2200 |
| 20103    | 2225 | 25609    | 2000 | 95925    | 1600 | 203528   | 2000 | 205755   | 3800 | 208071   | 2000 |
| 20153    | 2225 | 25612    | 2300 | 95938    | 2500 | 203534   | 3200 | 205772   | 2860 | 208072   | 4000 |
| 20286    | 2225 | 25613    | 2000 | 95939    | 2300 | 203535   | 3200 | *205776  | 4600 | 208077   | 2200 |
| 20350    | 2600 | 25614    | 2000 | 95946    | 2500 | 203536   | 3400 | 205777   | 1900 | 208080   | 2200 |
| 20351    | 2225 | 25622    | 2200 | 95965    | 2700 | 203541   | 2600 | 205778   | 4600 | 208082   | 2000 |
| 20369    | 1925 | 25623    | 2200 | 95967    | 3300 | 204089   | 2500 | 205779   | 4600 | 208084   | 2200 |
| 20375    | 1950 | 25627    | 2200 | 95970    | 3300 | 205063   | 3800 | 205782   | 2700 | 208108   | 2900 |
| 20379    | 2225 | 25629    | 2200 | 95971    | 2700 | 205070   | 3700 | 205786   | 2800 | 208114   | 2100 |
| 20381    | 1900 | 25634    | 2200 | 95975    | 3300 | 205085   | 3200 | *205789  | 4600 | 208116   | 2000 |
| 20387    | 2000 | 25649    | 2400 | 95981    | 2700 | 205091   | 3700 | 206100   | 3300 | 208117   | 2000 |
| 20410    | 2500 | 25859    | 2075 | 96910    | 3300 | 205099   | 3200 | 206101   | 2700 | 208118   | 2400 |
| 20423    | 1925 | 60150    | 2200 | 96911    | 2400 | 205113   | 2400 | 206102   | 2700 | 208129   | 1900 |
| 20424    | 2000 | 60315    | 2700 | 96914    | 2500 | 205114   | 3200 | 206103   | 2700 | 208130   | 1900 |
| 20425    | 2000 | 60321    | 2000 | 96934    | 3300 | 205128   | 3200 | 206104   | 2700 | 208148   | 1900 |
| 20484    | 2000 | 60595    | 3300 | 96940    | 2700 | 205141   | 4500 | 206105   | 2700 | 208151   | 2000 |
| 20515    | 2600 | 60654    | 2000 | 96941    | 2920 | 205142   | 3700 | 206106   | 2700 | 208157   | 2000 |
| 20795    | 2200 | 60656    | 1925 | 96945    | 3300 | 205186   | 3400 | 206158   | 3500 | 208158   | 2000 |
| 20797    | 2000 | 60676    | 1950 | 96946    | 2700 | 205270   | 2630 | 206160   | 3000 | 208159   | 2000 |
| 20810    | 1850 | 60711    | 2000 | 201014   | 2200 | 205274   | 2640 | 206174   | 2900 | 208160   | 2200 |
| 20811    | 2300 | 60825    | 3200 | 201017   | 2200 | 205279   | 3500 | 206180   | 3500 | 208167   | 3000 |
| 20813    | 2300 | 60881    | 2000 | 201019   | 2700 | 205288   | 3450 | 206304   | 3800 | 208172   | 2400 |
| 20814    | 2300 | 60906    | 1925 | 201024   | 3300 | 205305   | 2900 | 206327   | 3200 | 208176   | 3200 |
| 20815    | 2000 | 60940    | 1925 | 201025   | 2200 | 205318   | 3200 | 206340   | 3800 | 208177   | 2400 |
| 20818    | 2200 | 60975    | 2200 | 201027   | 2100 | 205505   | 2800 | 206341   | 3000 | 208179   | 2900 |
| 20819    | 2000 | 95011    | 3600 | 201036   | 2200 | 205507   | 3050 | 206351   | 3300 | 208180   | 2000 |
| 20820    | 1950 | 95065    | 2125 | 201043   | 2750 | 205521   | 3200 | 206352   | 4200 | 208182   | 1950 |
| 20849    | 1950 | 95090    | 2000 | 201516   | 1800 | 205530   | 3800 | 206359   | 4200 | 208183   | 3000 |
| 20860    | 2100 | 95158    | 3500 | 201520   | 2000 | 205534   | 3100 | 206360   | 4200 | 208185   | 4000 |
| 20861    | 2100 | 95170    | 3000 | 201526   | 2000 | 205537   | 3100 | 206361   | 3000 | 208187   | 3300 |
| 20868    | 3400 | 95172    | 1900 | 202012   | 2500 | 205557   | 2400 | 206362   | 3800 | 208188   | 2200 |
| 20870    | 4200 | 95204    | 2000 | 202013   | 2500 | 205562   | 2900 | 206363   | 3000 | 208189   | 2200 |
| 20885    | 4200 | 95208    | 2225 | 202014   | 2300 | 205563   | 2250 | 206364   | 3000 | 208190   | 2000 |
| 20910    | 2900 | 95261    | 3000 | 202015   | 2900 | 205565   | 3500 | 206367   | 3500 | 208199   | 2000 |
| 20914    | 3400 | 95285    | 2000 | 202016   | 2000 | 205567   | 3200 | 206371   | 3000 | 208203   | 2700 |
| 20933    | 2150 | 95293    | 2000 | 202022   | 2700 | 205571   | 2800 | 206372   | 3600 | 208206   | 2200 |
| 25030    | 4000 | 95294    | 2000 | 202024   | 2450 | 205577   | 2000 | 206373   | 3600 | 208254   | 2200 |
| 25046    | 4000 | 95302    | 2600 | 202025   | 2000 | 205579   | 2000 | 206375   | 2900 | 208256   | 2400 |
| 25048    | 2500 | 95303    | 2225 | 202029   | 2700 | 205581   | 2000 | 206376   | 2900 | 208264   | 3100 |
| 25177    | 3000 | 95305    | 2600 | 202034   | 2000 | 205582   | 2640 | 206378   | 2000 | 208272   | 2000 |
| 25226    | 3050 | 95306    | 2500 | 202035   | 2400 | 205589   | 2640 | 206382   | 3700 | 208273   | 2000 |
| 25256    | 3200 | 95311    | 1700 | 202037   | 1900 | 205591   | 2300 | 206383   | 3000 | 208277   | 2250 |
| 25282    | 3800 | 95323    | 2600 | 202040   | 1800 | 205592   | 2500 | 206386   | 3000 | 208278   | 2000 |
| 25300    | 3800 | 95340    | 2600 | 202064   | 2400 | 205593   | 2800 | 206464   | 2500 | 208284   | 2000 |
| 25305    | 2640 | 95403    | 2225 | 202312   | 3000 | 205599   | 2800 | 207010   | 3200 | 208285   | 4000 |
| 25306    | 2880 | 95430    | 2200 | 202514   | 2000 | 205600   | 3200 | 207012   | 3800 | 208289   | 1925 |
| 25314    | 2700 | 95461    | 2500 | 202517   | 1850 | 205605   | 2000 | 207015   | 3000 | 208291   | 1925 |
| 25381    | 2000 | 95462    | 2500 | 202522   | 3200 | 205608   | 2600 | 207016   | 3000 | 208307   | 2250 |
| 25421    | 2000 | 95467    | 2100 | 202523   | 3200 | 205610   | 2640 | 207022   | 3450 | 208312   | 2400 |
| 25429    | 2200 | 95475    | 2300 | 202524   | 2600 | 205624   | 2300 | 207023   | 3000 | 208313   | 2300 |
| 25453    | 2200 | 95480    | 2600 | 202526   | 2600 | 205626   | 2900 | 207024   | 3000 | 208324   | 2600 |
| 25457    | 2200 | 95486    | 2225 | 202527   | 1900 | 205627   | 2640 | 207106   | 3000 | 208605   | 2600 |
| 25458    | 2200 | 95488    | 2225 | 202529   | 3400 | 205631   | 3600 | 207110   | 2800 | 208609   | 2600 |
| 25459    | 2000 | 95526    | 2600 | 202544   | 2000 | 205634   | 3700 | 207119   | 2900 | 300065   | 2000 |
| 25460    | 2200 | 95528    | 2600 | 202549   | 1800 | 205635   | 2300 | 208055   | 2200 | 300085   | 2000 |
| 25461    | 2000 | 95561    | 2600 | 202553   | 1800 | 205644   | 2640 | 208057   | 2000 | 300096   | 3000 |

(See Following Page)

TABLE 4 - ENGINE SPEED SETTINGS FOR SPECIAL TYPE NUMBERS (CONT'D)

| TYPE NO. | RPM  | TYPE NO. | RPM  | TYPE NO. | RPM  | TYPE NO. | RPM  | TYPE NO. | RPM  | TYPE NO. | RPM  |
|----------|------|----------|------|----------|------|----------|------|----------|------|----------|------|
| 300099   | 2000 | 300324   | 2900 | 302083   | 2300 | 304285   | 2600 | 306168   | 3700 | **306704 | 4600 |
| 300108   | 2000 | 300328   | 1900 | 302087   | 2150 | 304287   | 2400 | 306169   | 2500 | *306705  | 4600 |
| 300110   | 1925 | 300329   | 3000 | 302104   | 2040 | 304289   | 2000 | 306170   | 2850 | *306707  | 4600 |
| 300138   | 2000 | 300335   | 3000 | 302107   | 2000 | 304298   | 2400 | 306173   | 3700 | **306708 | 4600 |
| 300140   | 2200 | 300337   | 3000 | 302108   | 2000 | 304299   | 2400 | 306179   | 2000 | *306709  | 4600 |
| 300145   | 2300 | 300342   | 3600 | 302113   | 1950 | 304303   | 2000 | 306184   | 3050 | 306713   | 4600 |
| 300149   | 2400 | 300348   | 2400 | 302127   | 2000 | 304304   | 2000 | 306186   | 2600 | 306714   | 4600 |
| 300150   | 2300 | 300349   | 1950 | 302136   | 2200 | 304310   | 2500 | 306187   | 2300 | 306715   | 4600 |
| 300155   | 2000 | 300362   | 2000 | 302138   | 2000 | 304311   | 2500 | 306198   | 2400 | 306717   | 4600 |
| 300176   | 2000 | 300376   | 2400 | 302142   | 2500 | 304312   | 2975 | 306210   | 3800 | 306718   | 4600 |
| 300177   | 2000 | 300385   | 2000 | 304054   | 2000 | 304332   | 1950 | 306219   | 3200 | 306719   | 4600 |
| 300181   | 2500 | 300410   | 2000 | 304089   | 2400 | 304566   | 2000 | 306233   | 3200 | 306722   | 4600 |
| 300183   | 1925 | 300411   | 2250 | 304106   | 2700 | 304572   | 2500 | 306234   | 2000 | 307007   | 2800 |
| 300185   | 3100 | 300414   | 2500 | 304114   | 2880 | 304576   | 2500 | 306236   | 2500 | 307010   | 2500 |
| 300188   | 2000 | 300420   | 2000 | 304124   | 2200 | 304578   | 2000 | 306247   | 1900 | 307013   | 2500 |
| 300193   | 2000 | 300503   | 2000 | 304131   | 2000 | 304580   | 2400 | 306252   | 2400 | 308105   | 2300 |
| 300194   | 2600 | 300504   | 1900 | 304132   | 2000 | 304584   | 2000 | 306255   | 2880 | 308130   | 2400 |
| 300199   | 2500 | 300506   | 2400 | 304134   | 2000 | 304585   | 3000 | 306303   | 2400 | 308135   | 2400 |
| 300201   | 2500 | 300507   | 3000 | 304135   | 2000 | 304591   | 2000 | 306304   | 3100 | 308145   | 2800 |
| 300203   | 2500 | 300517   | 1950 | 304146   | 2000 | 304596   | 2300 | 306305   | 2300 | 308154   | 2500 |
| 300205   | 2000 | 300520   | 2475 | 304147   | 2000 | 304597   | 2300 | 306312   | 2300 | 308161   | 2400 |
| 300207   | 2000 | 300527   | 2500 | 304151   | 2100 | 304598   | 3200 | 306314   | 2300 | 308180   | 2500 |
| 300208   | 2500 | 300531   | 3600 | 304160   | 2300 | 304602   | 2000 | 306315   | 2300 | 308211   | 2400 |
| 300209   | 2500 | 300534   | 2000 | 304186   | 2000 | 304604   | 2000 | 306317   | 2300 | 308217   | 2300 |
| 300210   | 2500 | 300547   | 2400 | 304192   | 2400 | 304606   | 2600 | 306324   | 3500 | 308227   | 3000 |
| 300211   | 2500 | 300550   | 3000 | 304193   | 2400 | 304607   | 2500 | 306325   | 2300 | 308512   | 2000 |
| 300213   | 2200 | 300551   | 2000 | 304194   | 2000 | 304614   | 2500 | 306326   | 2300 | 308513   | 3000 |
| 300214   | 2500 | 300554   | 2000 | 304195   | 2400 | 304621   | 2400 | 306327   | 2300 | 308522   | 2000 |
| 300215   | 2500 | 300559   | 2400 | 304196   | 2400 | 304646   | 2000 | 306330   | 2300 | 308528   | 2000 |
| 300216   | 2000 | 300562   | 2400 | 304197   | 2400 | 304647   | 2300 | 306409   | 2850 | 308530   | 3200 |
| 300217   | 2000 | 300564   | 2250 | 304199   | 2400 | 304648   | 2000 | 306514   | 2300 | 308523   | 3000 |
| 300218   | 1800 | 300566   | 1950 | 304200   | 2000 | 304653   | 2400 | 306515   | 3500 | 308539   | 2000 |
| 300219   | 2500 | 300570   | 2200 | 304202   | 2400 | 304691   | 2400 | 306516   | 3600 | 308540   | 3200 |
| 300220   | 2000 | 300578   | 2400 | 304203   | 2300 | 304698   | 2500 | 306517   | 3600 | 308548   | 2400 |
| 300223   | 2000 | 300582   | 2250 | 304204   | 2000 | 304704   | 2000 | 306522   | 2000 | 308563   | 2000 |
| 300224   | 1900 | 300583   | 2600 | 304205   | 2400 | 304780   | 2400 | 306523   | 3600 | 308564   | 2300 |
| 300225   | 1800 | 300593   | 3600 | 304207   | 2400 | 304801   | 2000 | 306525   | 3800 | 308576   | 2600 |
| 300226   | 2500 | 300597   | 3000 | 304208   | 2000 | 304872   | 2300 | 306529   | 4600 | 308578   | 2700 |
| 300227   | 2500 | 300600   | 2500 | 304209   | 2400 | 304873   | 2400 | 306536   | 3800 | 308581   | 2000 |
| 300228   | 2500 | 300606   | 1900 | 304210   | 2400 | 304876   | 1950 | 306547   | 2700 | 308583   | 3200 |
| 300229   | 1900 | 300608   | 2500 | 304211   | 2400 | 305101   | 2300 | 306548   | 4600 | 308584   | 2000 |
| 300239   | 2000 | 300610   | 1900 | 304212   | 2000 | 305110   | 2400 | 306549   | 3000 | 308589   | 3200 |
| 300246   | 3000 | 300615   | 2600 | 304214   | 2400 | 305112   | 2300 | 306555   | 3000 | 308597   | 2200 |
| 300248   | 2500 | 300628   | 2000 | 304215   | 2000 | 305116   | 2740 | 306556   | 3000 | 308753   | 2600 |
| 300249   | 2500 | 300725   | 2600 | 304216   | 1900 | 305119   | 2800 | 306557   | 3600 | 308754   | 2300 |
| 300250   | 2500 | 300734   | 2500 | 304220   | 2400 | 305129   | 2700 | 306561   | 3600 | 308758   | 3200 |
| 300251   | 2000 | 300736   | 2500 | 304225   | 2400 | 305133   | 3300 | 306562   | 3600 | 308759   | 2000 |
| 300253   | 2500 | 300749   | 2600 | 304226   | 3000 | 305311   | 2400 | 306583   | 3600 | 308769   | 2600 |
| 300254   | 415* | 300753   | 2500 | 304227   | 2400 | 305312   | 2400 | 306593   | 3800 | 308779   | 3200 |
| 300259   | 2500 | 300755   | 2500 | 304228   | 2400 | 306109   | 2700 | 306597   | 3000 | 308790   | 2300 |
| 300265   | 2500 | 300756   | 2500 | 304234   | 2400 | 306110   | 3200 | 306598   | 3600 | 308904   | 2200 |
| 300266   | 2300 | 300801   | 2500 | 304236   | 2400 | 306111   | 2600 | 306604   | 3600 | 308906   | 3200 |
| 300275   | 3000 | 300802   | 1900 | 304237   | 3100 | 306112   | 3000 | 306606   | 3600 | 700039   | 3300 |
| 300280   | 3000 | 300804   | 2500 | 304238   | 2600 | 306113   | 2900 | 306619   | 3600 | 700043   | 3000 |
| 300282   | 2300 | 300807   | 1900 | 304239   | 2500 | 306119   | 2900 | 306620   | 3000 | 700045   | 2300 |
| 300285   | 2500 | 300879   | 3000 | 304241   | 2700 | 306121   | 2000 | 306634   | 2600 | 700046   | 2800 |
| 300287   | 2400 | 301117   | 3000 | 304242   | 2500 | 306123   | 3200 | 306635   | 3800 | 700052   | 2900 |
| 300292   | 2700 | 301139   | 2900 | 304246   | 2500 | 306126   | 2860 | 306638   | 3000 | 701023   | 2800 |
| 300296   | 3000 | 301146   | 2400 | 304251   | 2400 | 306127   | 2750 | 306645   | 2600 | 701029   | 2300 |
| 300297   | 3000 | 301149   | 3300 | 304252   | 2200 | 306128   | 3700 | 306650   | 2600 | 701053   | 2800 |
| 300300   | 2700 | 301152   | 2400 | 304260   | 2000 | 306131   | 2800 | 306654   | 3850 | 701058   | 2400 |
| 300302   | 2900 | 301155   | 2000 | 304263   | 2000 | 306135   | 3000 | 306657   | 3850 | 702037   | 2500 |
| 300303   | 3000 | 301168   | 2900 | 304271   | 2400 | 306150   | 2400 | 306658   | 2600 | 702058   | 2750 |
| 300306   | 1800 | 301305   | 3300 | 304272   | 2000 | 306152   | 2080 | 306661   | 3950 | 702518   | 3600 |
| 300307   | 2000 | 301307   | 2400 | 304273   | 2000 | *306153  | 4600 | 306663   | 3800 | 702526   | 3600 |
| 300312   | 3800 | 301312   | 2900 | 304274   | 2000 | 306155   | 3200 | *306702  | 4600 | 702528   | 2600 |
| 300314   | 2880 | 301318   | 2400 | 304283   | 2000 | 306157   | 3000 | *306703  | 4600 | 702530   | 2600 |

\*Place lower end of throttle link in outer hole in governor lever. Place governor spring in number 6 hole in governor lever.

\*Place governor spring in number 2 hole in governor lever.

\*\*Place governor spring in number 6 hole in governor lever. Otherwise standard.

▼Serial Numbers 19188 to 19191 - 19193 to 19199 - 19200 to 19213 - 19215 to 19227. Set at 2900 RPM.

TABLE NO. 5 - SPEED SETTINGS FOR STANDARD ENGINES

The engine speed should be set to the RPM shown in the "Standard Speed Setting" column unless otherwise noted in Table 4 or requested by the owner. The Standard Speed setting allows for a drop in RPM when the load is applied.

For illustrations of carburetor and governor hookups see the Figures listed.

| MODEL            | 5 DIGIT TYPE NUMBERS         |                                |                    | SEE FIG. | 6 DIGIT TYPE NUMBERS         |                                |                    | SEE FIG.       |
|------------------|------------------------------|--------------------------------|--------------------|----------|------------------------------|--------------------------------|--------------------|----------------|
|                  | OPERATING SPEED RANGE R.P.M. | STANDARD SPEED SETTING NO LOAD | IDLE SPEED NO LOAD |          | OPERATING SPEED RANGE R.P.M. | STANDARD SPEED SETTING NO LOAD | IDLE SPEED NO LOAD |                |
| A                | 2200-3200                    | 2400                           | 1400               | 70       | 2200-3200                    | 2900                           | 1400               | 71             |
| AGR-4            | 500-600*                     | 560*                           | 350*               | 70       |                              |                                |                    |                |
| AH-AHL-AHLP-AHP  | 2200-3200                    | 2900                           | 1400               | 70       |                              |                                |                    |                |
| AHM-AHMT         | 2200-3200                    | 2900                           | 1400               | 70       |                              |                                |                    |                |
| AHR-4            | 550-800*                     | 750*                           | 350                | 70       |                              |                                |                    |                |
| AHR-6            | 370-530*                     | 483*                           | 235*               | 70       |                              |                                |                    |                |
| AL-ALP-AP        | 2200-2400                    | 2400                           | 1400               | 70       | 2200-3200                    | 2900                           | 1400               | 71             |
| ALR-4 - AR-4     | 500-600*                     | 600*                           | 350*               | 70       |                              |                                |                    |                |
| ALR-6 - AR-6     | 330-400*                     | 400*                           | 235*               | 70       | 365-530*                     | 483*                           | 235*               | 71             |
| AM-AMT           | 2000-2400                    | 2400                           | 1400               | 70       |                              |                                |                    |                |
| B-BP             | 2300-2700                    | 2700                           | 1400               | 72 to 77 | 2200-3200                    | 2900                           | 1400               | 72 to 77       |
| BH BHL BHL P BHP | 2200-3200                    | 2900                           | 1400               | 72 to 77 | 2200-3200                    | 2900                           | 1400               | 72 to 77       |
| BHM              | 2200-3200                    | 2900                           | 1400               | 72 to 77 |                              |                                |                    |                |
| BHLR-4 - BHR-4   | 750-900*                     | 750*                           | 350*               | 72 to 77 |                              |                                |                    |                |
| BHLR6-BHR6       | 500-600*                     | 483*                           | 235*               | 72 to 77 |                              |                                |                    |                |
| BL-BLP           | 2300-2700                    | 2700                           | 1400               | 72 to 77 | 2200-3200                    | 2900                           | 1400               | 72 to 77       |
| BLR4-BR-4        | 575-675*                     | 675*                           | 350*               | 72 to 77 | 550-800*                     | 725*                           | 350*               | 72 to 77       |
| BLR-6 - BR-6     | 380-450*                     | 450*                           | 235*               | 72 to 77 | 365-530*                     | 483*                           | 235*               | 72 to 77       |
| BM-BMG           | 2300-2700                    | 2700                           | 1400               | 72 to 77 | 2200-3200                    | 2900                           | 1400               | 72 to 77       |
| FH               | 1750-1800                    | 1950                           | 1400               | 78       |                              |                                |                    |                |
| FHI              | 1750-1800                    | 1950                           | 1400               | 77       |                              |                                |                    |                |
| FI               | 1750-1900                    | 2100                           | 1400               | 79       |                              |                                |                    |                |
| FJI              | 3000-4000                    | 4000                           | 1400               | 70       |                              |                                |                    |                |
| FJ2              | 1800-2400                    | 2400                           | 1400               | 70       |                              |                                |                    |                |
| H-HM             | 1750-2100                    | 1950                           | 1400               | 80       |                              |                                |                    |                |
| I                |                              |                                |                    |          | 2600-3600                    | 3300                           | 1750               | 82-83-87-88-89 |
| IBHP             | 2100-3600                    | 3300                           | 1750               | 81       |                              |                                |                    |                |
| IB-IBLP          | 2600-3200                    | 3100                           | 1750               | 81       |                              |                                |                    |                |
| IBP-IP           | 2600-3200                    | 3100                           | 1750               | 81       | 2600-3200                    | 2900                           | 1750               | 81             |
| IL               |                              |                                |                    |          | 2600-3200                    | 2900                           | 1750               | 81             |
| ILR6-IR6         | 435-535*                     | 483*                           | 290                | 81       | 430-670*                     | 483*                           | 290*               | 81             |
| IMT              | 2600-3200                    | 3100                           | 1750               | 81       | 2600-3200                    | 2900                           | 1750               | 81             |
| IPR-1.6          |                              |                                |                    |          | 1625-2250*                   | 2062*                          | 1100*              | 81             |
| IPR-6            |                              |                                |                    |          | 433-600*                     | 550*                           | 290*               | 81             |
| IR-2             | 1300-1600*                   | 1550*                          | 875                | 81       | 1300-1800*                   | 1650*                          | 875*               | 81             |
| IR-6             | 435-535*                     | 483*                           | 290                | 81       | 430-600*                     | 550*                           | 290*               | 81             |
| IS               |                              |                                |                    |          | 2600-4200                    | 3600                           | 1750               |                |
| K-KL-KLP-KP      | 2300-2700                    | 2700                           | 1400               | 72 to 77 | 2300-2700                    | 2700                           | 1400               | 72 to 77       |
| KLR-4 - KR-4     | 575-675*                     | 700*                           | 350*               | 72 to 77 | 575-675*                     | 700*                           | 350*               | 72 to 77       |
| KLR-6 - KR-6     | 390-450*                     | 443*                           | 235*               | 72 to 77 | 390-450*                     | 443*                           | 235*               | 72 to 77       |
| KM               | 2300-2700                    | 2700                           | 1400               | 72 to 77 | 2300-2700                    | 2700                           | 1400               | 72 to 77       |
| L-LA             | 1700-1900                    | 1950                           | 1400               | 84       |                              |                                |                    |                |
| M-MC             | 1800-2400                    | 2400                           | 1400               | 70       |                              |                                |                    |                |
| MB-MF            | 1800-2400                    | 2400                           | 1400               | 85       |                              |                                |                    |                |
| MH               | 3000-4000                    | 3900                           | 1400               | 70       |                              |                                |                    |                |

(See Following Page)

TABLE NO. 5 - SPEED SETTINGS FOR STANDARD ENGINES (CONT'D)

| MODEL           | 5 DIGIT TYPE NUMBERS         |                                |                    | SEE FIG. | 6 DIGIT TYPE NUMBERS         |                                |                    | SEE FIG.    |
|-----------------|------------------------------|--------------------------------|--------------------|----------|------------------------------|--------------------------------|--------------------|-------------|
|                 | OPERATING SPEED RANGE R.P.M. | STANDARD SPEED SETTING NO LOAD | IDLE SPEED NO LOAD |          | OPERATING SPEED RANGE R.P.M. | STANDARD SPEED SETTING NO LOAD | IDLE SPEED NO LOAD |             |
| H-MP            |                              |                                |                    |          | 2600-3600                    | 3300                           | 1750               | 83-86 to 90 |
| HPR-1.6         |                              |                                |                    |          | 1625-2250*                   | 2060*                          | 1100*              | 83-86 to 90 |
| HPR-6           |                              |                                |                    |          | 433-650*                     | 550*                           | 290*               | 83-86 to 90 |
| HR-2            |                              |                                |                    |          | 1300-1800*                   | 1650*                          | 875*               | 83-86 to 90 |
| HR-6            |                              |                                |                    |          | 435-670*                     | 583*                           | 290*               | 83-86 to 90 |
| HS              |                              |                                |                    |          | 2200-3200                    | 3300                           | 1750               | 98          |
| HSPR-1.6        |                              |                                |                    |          | 1380-2000*                   | 2060*                          | 1100*              | 98          |
| HSPR-6          |                              |                                |                    |          | 366-533*                     | 550*                           | 290*               | 98          |
| PB              | 2100-2300                    | 2400                           | 1400               | 90       |                              |                                |                    |             |
| Q               | 1700-1900                    | 2000                           | 1400               | 91       |                              |                                |                    |             |
| R-RC            | 1800-2400                    | 2600                           | 1400               | 92       |                              |                                |                    |             |
| S-SC            | 1700-1900                    | 2000                           | 1400               | 93       |                              |                                |                    |             |
| T               | 1700-1900                    | 2000                           | 1400               | 70       |                              |                                |                    |             |
| TA              | 1700-1900                    | 2000                           | 1400               | 85       |                              |                                |                    |             |
| U               |                              |                                |                    |          | 2200-3200                    | 2900                           | 1750               | 94-95       |
| UR-2            |                              |                                |                    |          | 1100-1600*                   | 1450*                          | 875*               | 94-95       |
| UR-6            |                              |                                |                    |          | 365-530*                     | 483*                           | 290*               | 94-95       |
| V-WA            | 1800-2400                    | 2000                           | 1400               | 92       |                              |                                |                    |             |
| WB              | 2300                         | 2500                           | 1750               | 96-97    | 2300                         | 2500                           | 1750               | 96-97       |
| WI-WISP         | 2200-3200                    | 2900                           | 1750               | 96-97    | 2200-3200                    | 2700                           | 1750               | 98          |
| WIPR-1.6        |                              |                                |                    |          | 1380-2000*                   | 1688*                          | 1100*              | 98          |
| WIPR-6          |                              |                                |                    |          | 366-533*                     | 450*                           | 290*               | 98          |
| WM              | 2250-2800                    | 2250                           | 1750               | 96-97    |                              |                                |                    |             |
| WMB             | 2250-2800                    | 2250                           | 1750               | 96-97    | 2200-2800                    | 2250                           | 1750               | 96-97       |
| WNG             | 2300                         | 2500                           | 1750               | 96-97    |                              |                                |                    |             |
| WMI-WMIP        | 2100-2500                    | 2500                           | 1750               | 96-97    |                              |                                |                    |             |
| WR-6            | 365-530*                     | 458*                           | 290*               | 96-97    | 383-533*                     | 483*                           | 290*               | 96-97       |
| Y               | 1700-1900                    | 1950                           | 1400               | 99       |                              |                                |                    |             |
| Z-ZL-ZLP-ZP     | 2200-2600                    | 2600                           | 1400               | 72 to 77 | 2200-3200                    | 2900                           | 1400               | 72 to 77    |
| ZH-ZHL-ZHLP-ZHP | 2200-3200                    | 3100                           | 1400               | 72 to 77 | 2200-3200                    | 2900                           | 1400               | 72 to 77    |
| ZHLR-4-ZHR-4    | 550-800*                     | 775*                           | 350*               | 72 to 77 | 550-800*                     | 725*                           | 350*               | 72 to 77    |
| ZHLR-6-ZHR-6    | 370-530*                     | 515*                           | 235*               | 72 to 77 | 370-530*                     | 483*                           | 235*               | 72 to 77    |
| ZHM             | 2200-3200                    | 3100                           | 1400               |          |                              |                                |                    |             |
| ZLR-4-ZR-4      | 550-630*                     | 650*                           | 350*               | 72 to 77 | 550-800*                     | 725*                           | 350*               | 72 to 77    |
| ZLR-6-ZR-6      | 360-430*                     | 433*                           | 235*               | 72 to 77 | 365-530*                     | 483*                           | 235*               | 72 to 77    |
| ZM-ZMG          | 2200-2600                    | 2600                           | 1400               | 72 to 77 | 2200-3200                    | 2900                           | 1400               | 72 to 77    |
| ZZ-ZZL-ZZLP-ZZP |                              |                                |                    |          | 2200-3200                    | 2900                           | 1400               | 72 to 77    |
| ZZR-6           |                              |                                |                    |          | 365-530*                     | 483*                           | 235*               | 72 to 77    |
| 5               |                              |                                |                    |          | 2600-3600                    | 3300                           | 1750               | 82 to 89    |
| 5S              |                              |                                |                    |          | 2200-3200                    | 2700                           | 1750               | 102-103     |
| 6S              |                              |                                |                    |          | 2200-3200                    | 3000                           | 1750               | 102-103     |
| 6H-6HF-8H-8HF   |                              |                                |                    |          | 2600-3600                    | 3300                           | 1750               | 106-108     |
| 8               |                              |                                |                    |          | 2600-3600                    | 3300                           | 1750               | 86 to 90    |
| 9               |                              |                                |                    |          | 2200-3200                    | 2900                           | 1200               | 100-101     |
| 9R6             |                              |                                |                    |          | 365-533*                     | 483*                           | 200*               | 100-101     |
| 14              |                              |                                |                    |          | 2200-3200                    | 2900                           | 1200               | 100-101     |
| 14R6            |                              |                                |                    |          | 365-533*                     | 483*                           | 200*               | 100-101     |
| 23              |                              |                                |                    |          | 2200-3200                    | 2900                           | 1200               | 100-101     |
| 23R6            |                              |                                |                    |          | 365-533*                     | 483*                           | 200*               | 100-101     |
| 6HS-6HSF        |                              |                                |                    |          | 2200-3200                    | 3000                           | 1750               | 104-105     |

\*This indicates the speed at power take-off side on gear reduction models. It is 1/2, 1/4 or 1/6 of engine speed as indicated by the numeral following the engine model letter. Engine speed on magneto side is the same as standard.

## IGNITION

Briggs & Stratton ignition systems may be divided into four general groups which are similar in many ways:

1. TYPE A. Used on Models A-B-H-K-Y-Z-ZZ. See Page. 18
2. TYPE FH. Used on Models FH-FI-FJ-L-M-PB-Q-R-S-T-W. See Page 20.
3. TYPE N. Used on Models I-N-NS-U-WI-WM-WMB-5-6-8. See Page. 21.
4. MAGNEMATIC. Used on Models 9-14-23. See Page. 23.

Current is produced by a coil, condenser, breaker points and rotating magnets and is conducted into the firing chamber through the ignition cable and spark plug. It is important that all parts be in good condition, correctly adjusted and properly connected to assure a good spark.

### SPARK PLUG

The plugs recommended for Briggs & Stratton engines are listed in Table No 3 and should be installed unless special engine use requires a plug of a different heat range.

#### To Check Spark Plug

Clean spark plug and set gap to .025". Fig. 2. If a sand blaster is used to clean spark plug, be sure to clean the inner side of the electrode with a point hone or sand paper. If electrodes are burned away, or if porcelain is cracked, replace with a new plug of the proper heat range. Before assembling the spark plug, place a little graphite grease on the threads to prevent sticking.

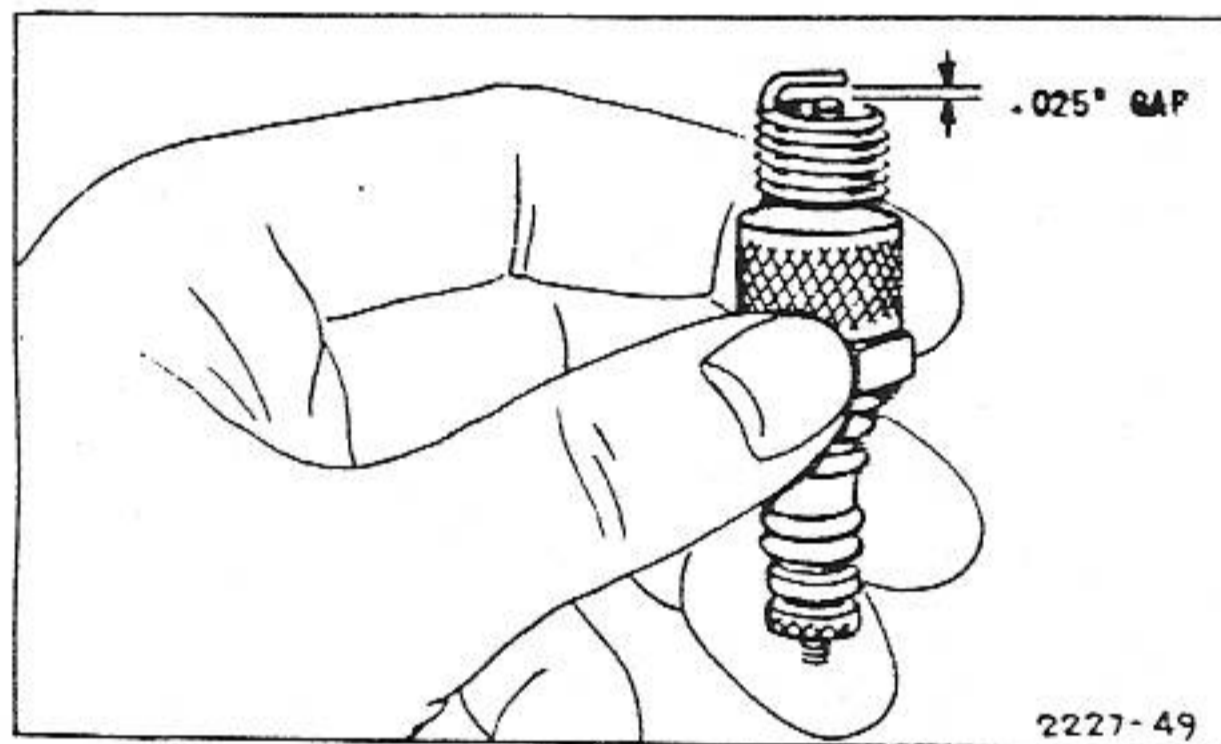


FIG. 2—CHECKING FOR SPARK GAP

#### Model FI

Check the spark plug firing hole in the cylinder head. If the hole is larger than  $\frac{1}{4}$ ", install a spark plug nipple, Part No. 67773.

#### To Check Spark, Engine Not Running

It is easy to check the spark when the magneto is assembled to the engine. Remove spark plug. Hold spark tester No. MPJ-T7 on cylinder head with a single electrode grounded. Fasten ignition cable to double electrode. Fig. 3. Spin flywheel vigorously. Spark should jump the .166" gap steadily. The spark may also be tested by holding the end of the ignition cable about  $\frac{1}{8}$ " from any metal part of the engine and spinning the flywheel. Fig. 4. However, this test is not very accurate unless the cable is held steadily at  $\frac{1}{8}$ " from the engine while spinning flywheel.

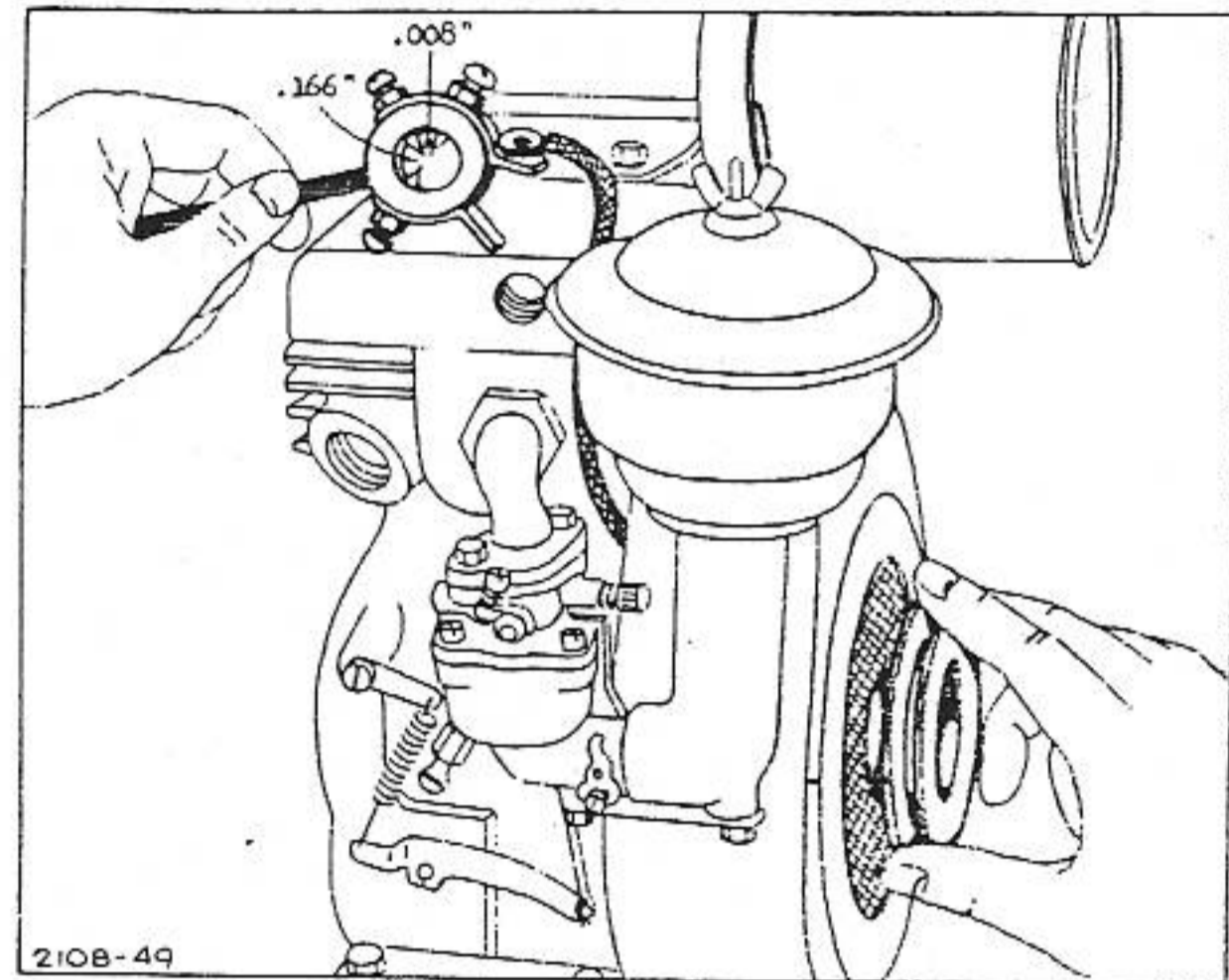


FIG. 3—CHECKING SPARK

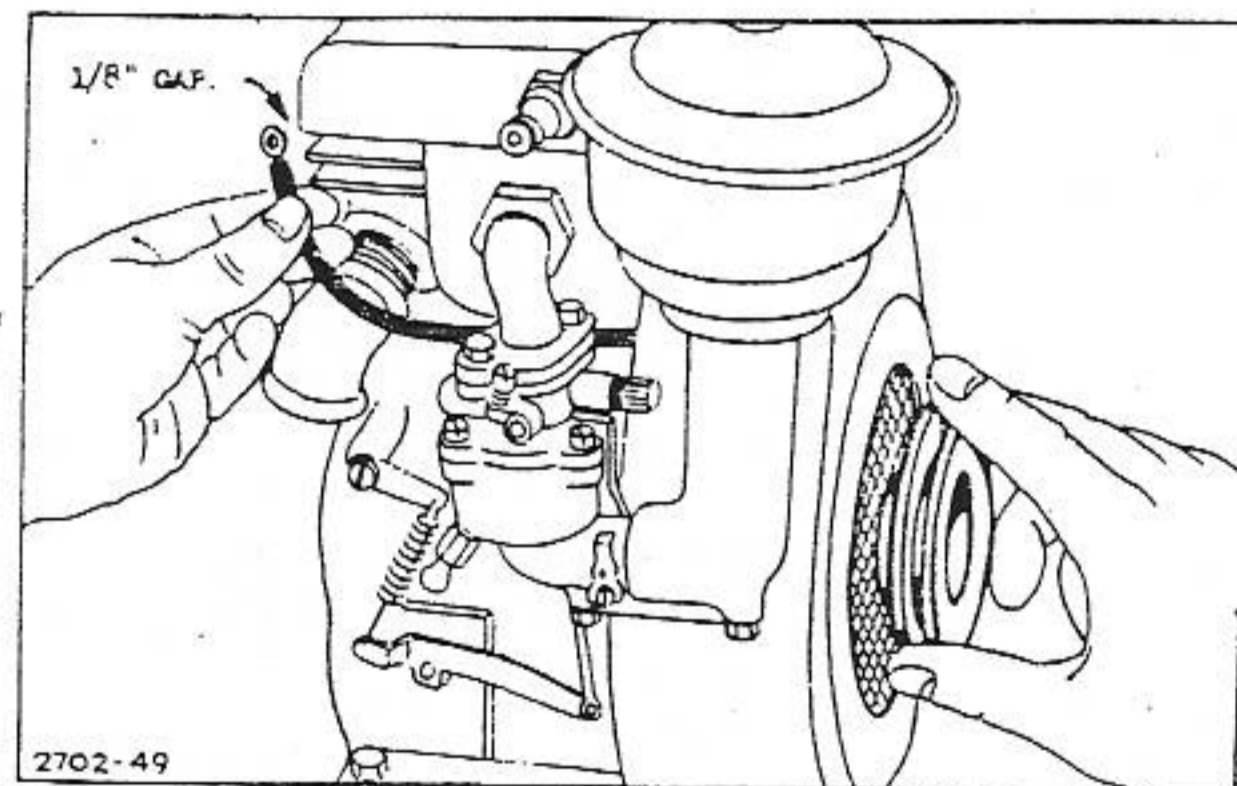


FIG. 4—CHECKING SPARK

#### To Check Spark with Engine Running All Models Except 9-14-23

With the spark plug nut removed and the engine running, hold spark tester in the one hand and grasp ignition cable with the other hand. Do not touch the metal terminal on end of cable. Then quickly lift the ignition cable from the spark plug; ground single electrode of tester to spark plug screw and hold cable terminal to the connector of double electrodes on tester. Fig. 5. The spark should jump the .166" gap without missing and the engine should run steadily.

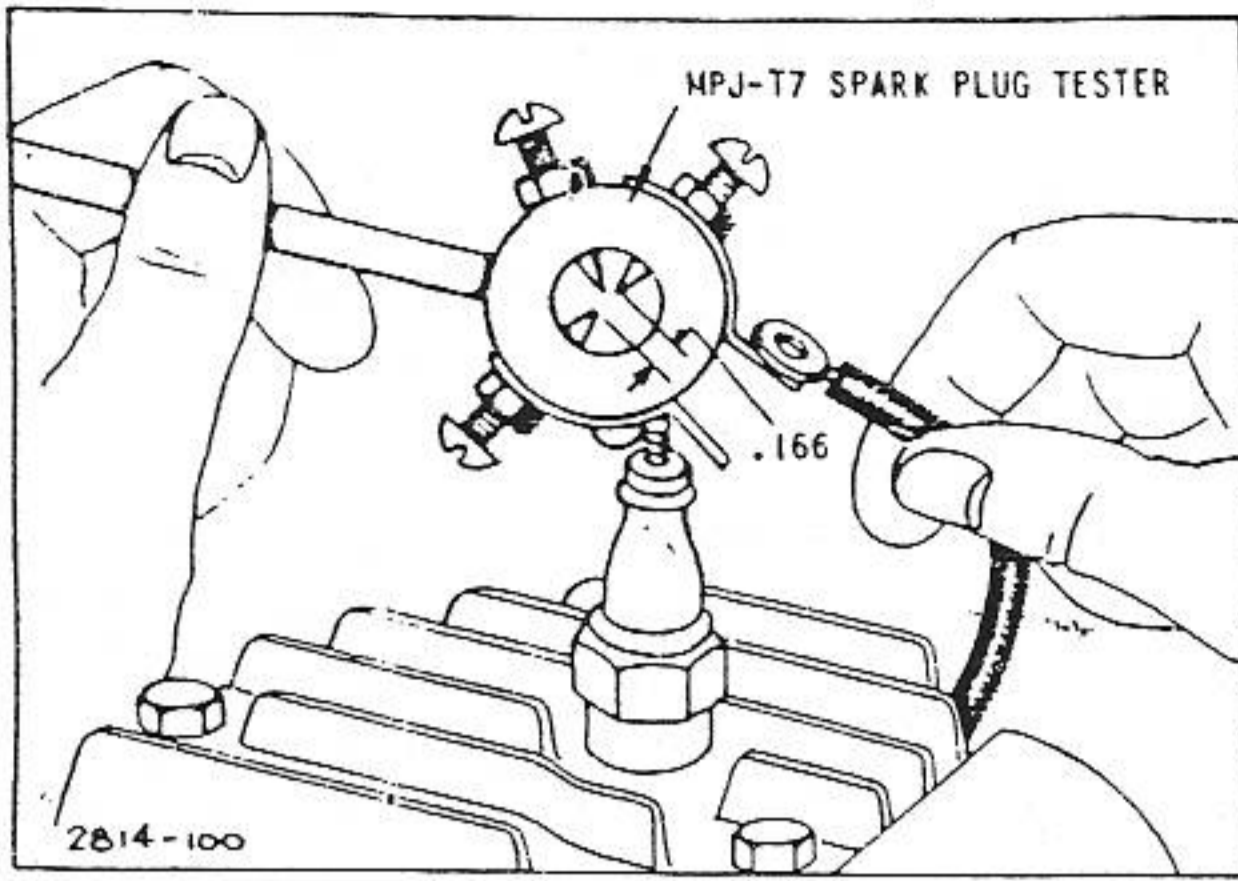


FIG. 5—CHECKING SPARK

**Models 9-14-23**

The running spark on these models should be tested by using a new spark plug with a .050" gap at the electrode. If the engine will start and accelerate properly with this .050" gap, the spark is satisfactory. Do not use spark tester MPJ-T7. Also, do not overspeed the engine while checking the spark.

**BREAKER POINT GAP**

The point gap on all models is .020". Points should be clean and line up squarely.

**BREAKER POINT TENSION**

1. Models A-B-H-K-Y-Z-ZZ, 16 to 20 ozs. To adjust see page. 18.
2. Models 9-14-23, no adjustment possible.
3. All 2" bore models and Model 8, 12 to 16 ozs. To adjust see page. 21.

**CONDENSER**

The capacity of all condensers is .16 to .24 MFD.

**BLOWER HOUSING****To Remove Blower Housing**

The blower housings on most models are easily removed, but on Models 9-14-23 and rope starter Models A-B-K-Z-ZZ, the rope starter pulley must be removed before the blower housing as follows:

**Models A-B**

Place a rod or punch through the  $\frac{3}{8}$ " hole in the blower

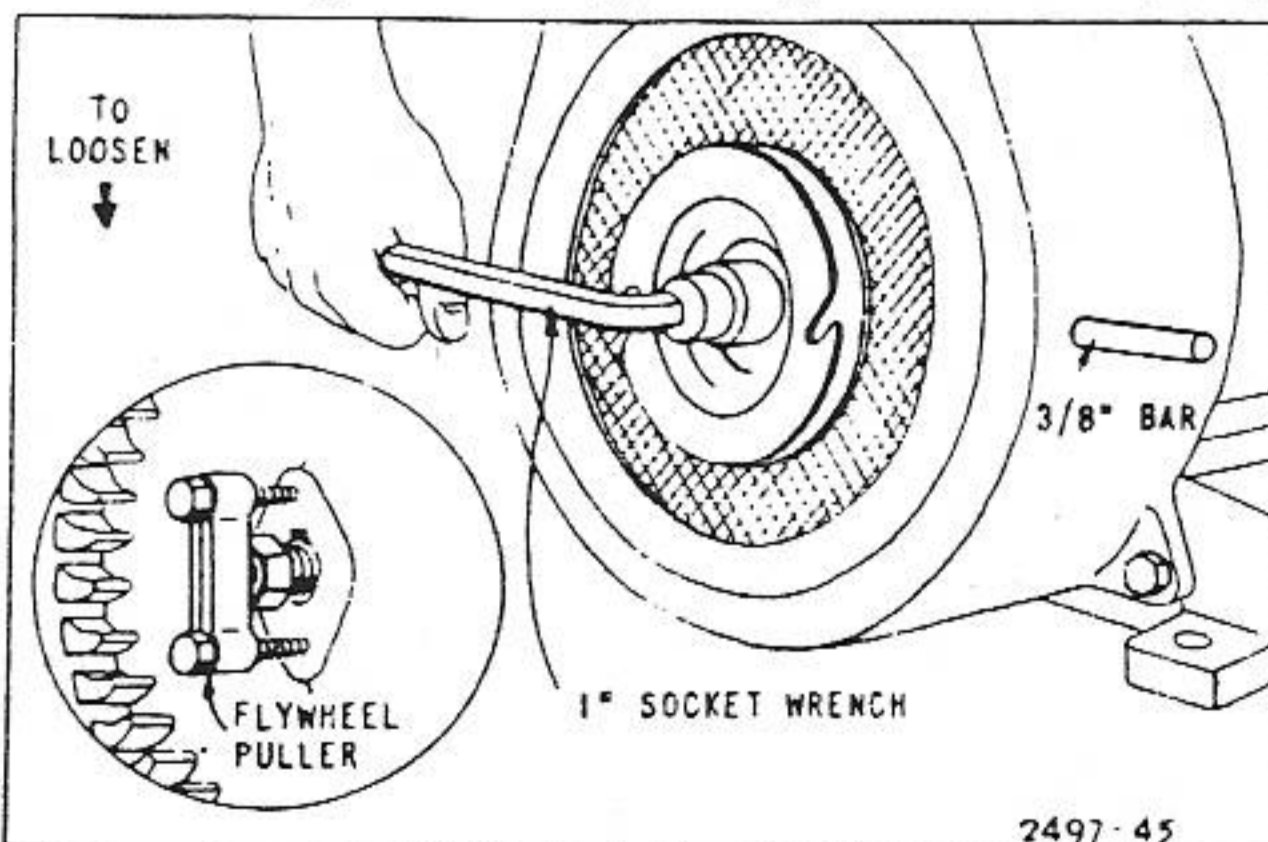


FIG. 6 — REMOVING FLYWHEEL

housing on the fuel tank side so that the rod passes between fins on flywheel. This will lock the flywheel so that the flywheel nut may be loosened. Fig. 6.

**Models 9-14-23-K-Z-ZZ**

Remove the two cap screws that hold starter pulley to the flywheel. Blower housing can then be removed.

**FLYWHEEL**

The flywheel on most models is located on the crankshaft with a soft metal key. It is held in place by means of a taper fit and a nut on rope starter engines, and a pinion gear on most crank starter engines. The flywheel key must be in good condition to assure proper location of the flywheel for ignition purposes. DO NOT use a STEEL key under any conditions. Use only the soft metal key as originally supplied. The keyway in both flywheel and crankshaft should be in good condition.

**To Remove The Flywheel**

First, remove the locking plate, if any, then loosen the flywheel nut or pinion by using a block of wood to keep the flywheel from turning as shown in Fig. 7. Remove nut, lockwasher or nut lock, and starter pulley. Reassemble nut until it is flush with the end of crankshaft, then strike end of crankshaft a sharp blow with a babbitt or rawhide hammer to jar flywheel loose.

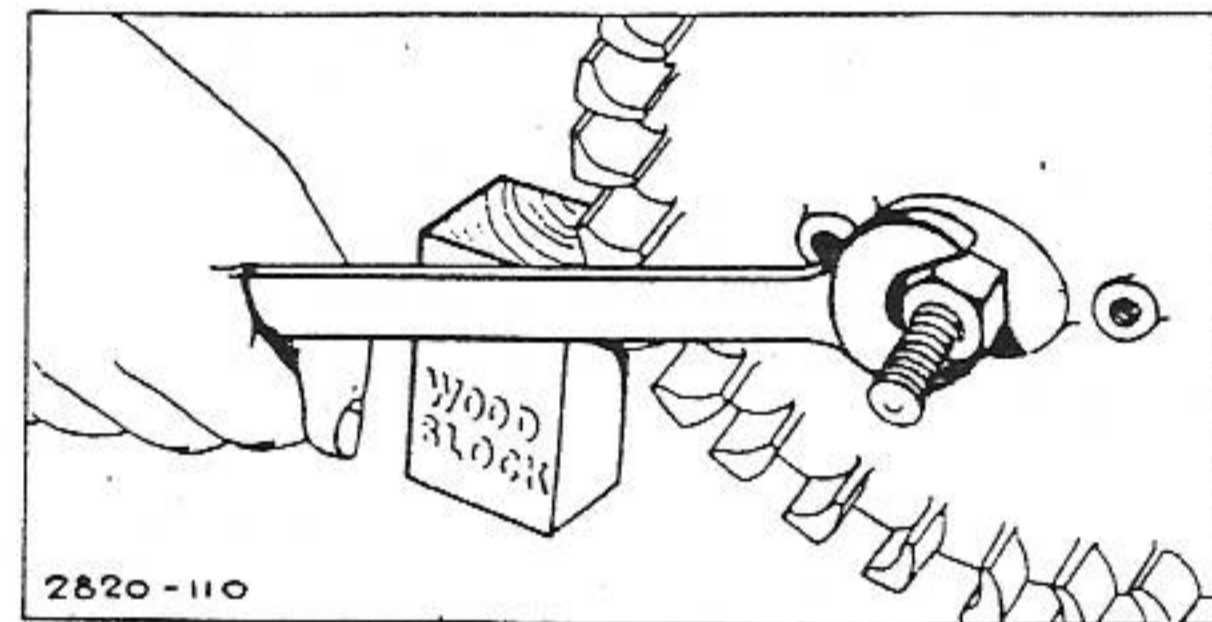


FIG. 7 — REMOVING FLYWHEEL

Special instructions:

**Models A-B**

Use flywheel puller No. 29157 to remove flywheel. Fig. 8.

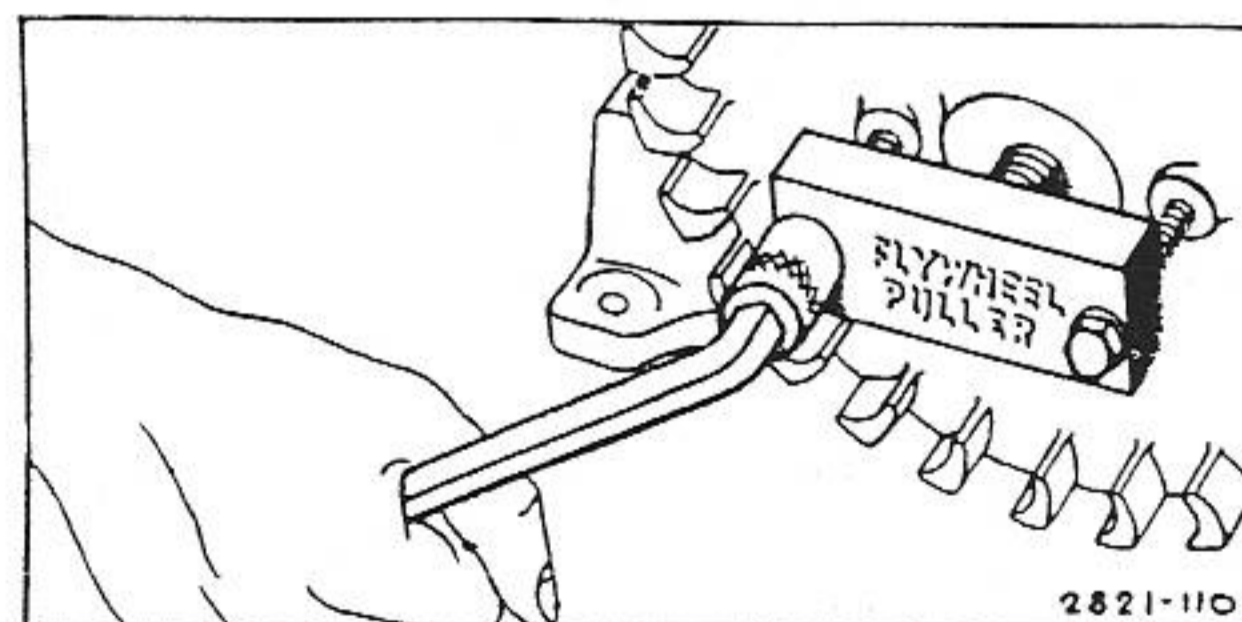


FIG. 8 — REMOVING FLYWHEEL

**Models I-N-NS-U-WI-WM-WMB-WMI-5-6-8**

The nut on most of these engines has a left hand thread. Use flywheel holder No. 61741-T19 while loosening nut. Fig. 9.

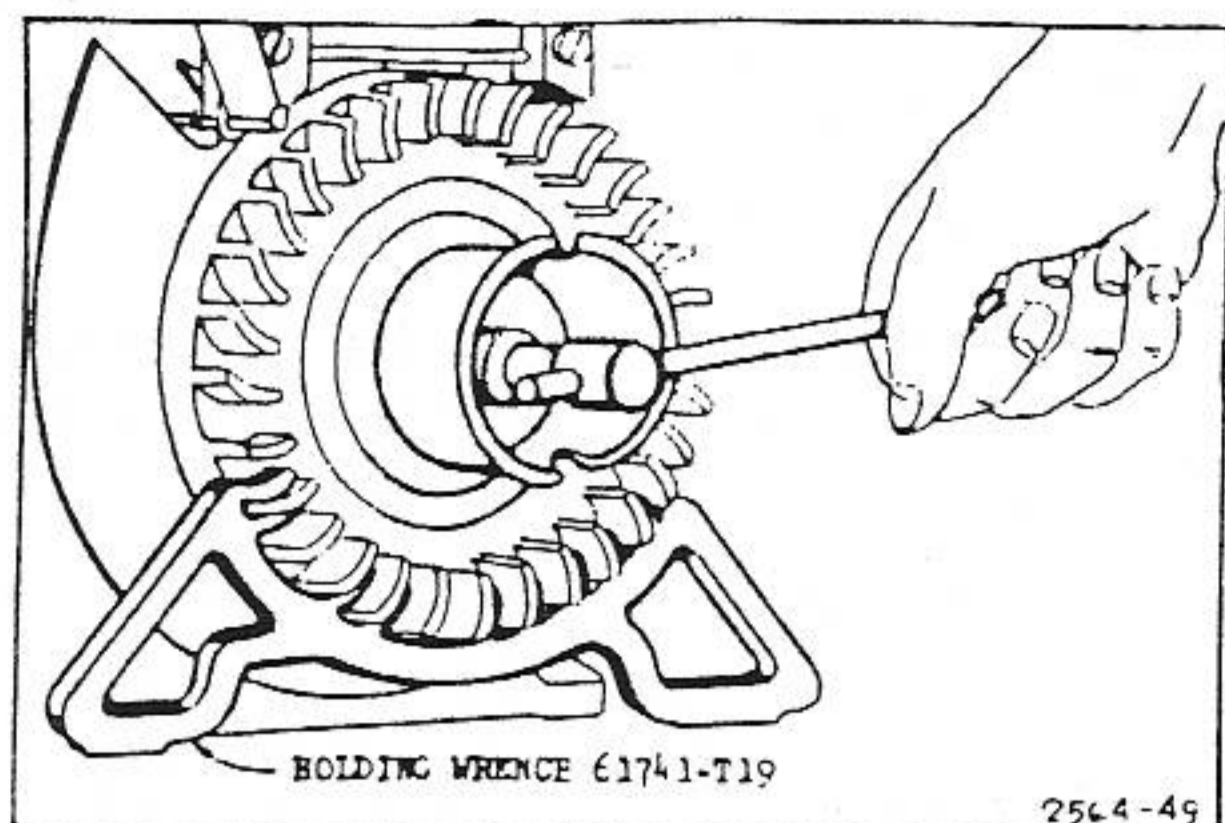


FIG. 9 — REMOVING FLYWHEEL

**Models K-Z-ZZ**

Place a rod or punch into the hole drilled into rim of flywheel to prevent its turning while loosening nut or pinion. Use flywheel puller No. 29020.

**Models 9-14-23**

Remove flywheel nut. Be careful not to damage the starter pin on the flywheel. Use flywheel puller No. 291547 to loosen flywheel. Fig. 8. It is not necessary to remove flywheel to adjust or replace breaker points or condenser.

**Models H-Y**

The flywheel is mounted to the crankshaft with a bolt and nut. Remove the starter lever, pedal, or pulley, and the blower housing. Loosen flywheel nut and bolt so that you can remove starter clutch assembly. Mark flywheel and crankshaft on the bolt head side. The flywheel hub has two shoulders, the one on the bolt head side is higher than the other. Remove nut and bolt. Use flywheel puller No. 29593. Fig. 10.

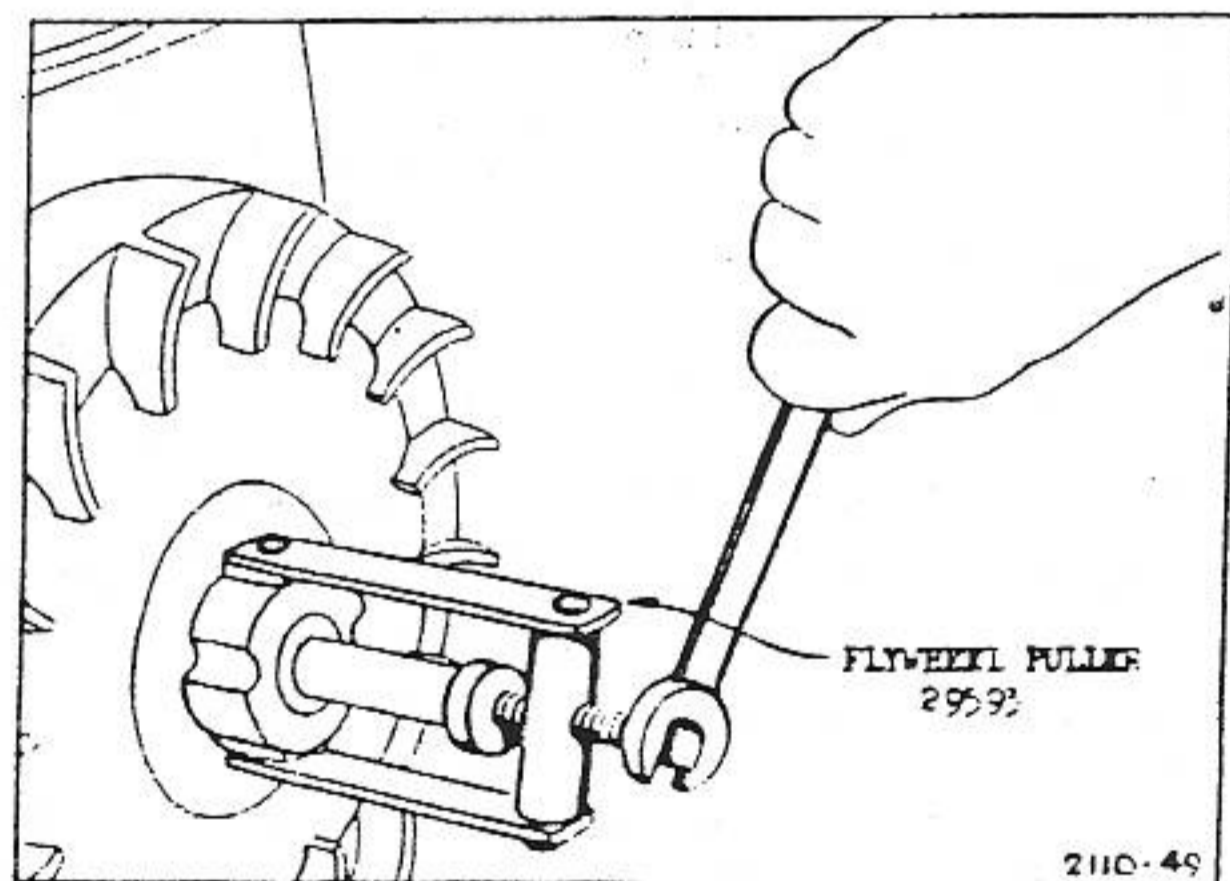


FIG. 10 — REMOVING FLYWHEEL

**To Assemble Flywheel**

Thoroughly clean taper of crankshaft and flywheel. Insert soft metal key into crankshaft keyway, then assemble flywheel. Be sure the key stays in place. Then assemble starter pulley, lockwasher and nut, or starter pinion, and lock as required. Tighten securely.

**Special instructions:****Models I-N-NS-WI-WM-WMB-WMI-5-6-8**

Assemble flywheel first, then insert soft metal key. Use flywheel holder No. 61741-T19. On engines used for

scooters, place a little grease on the inner side of the clutch housing to prevent shearing the tangs on the housing lock. Fig. 11.

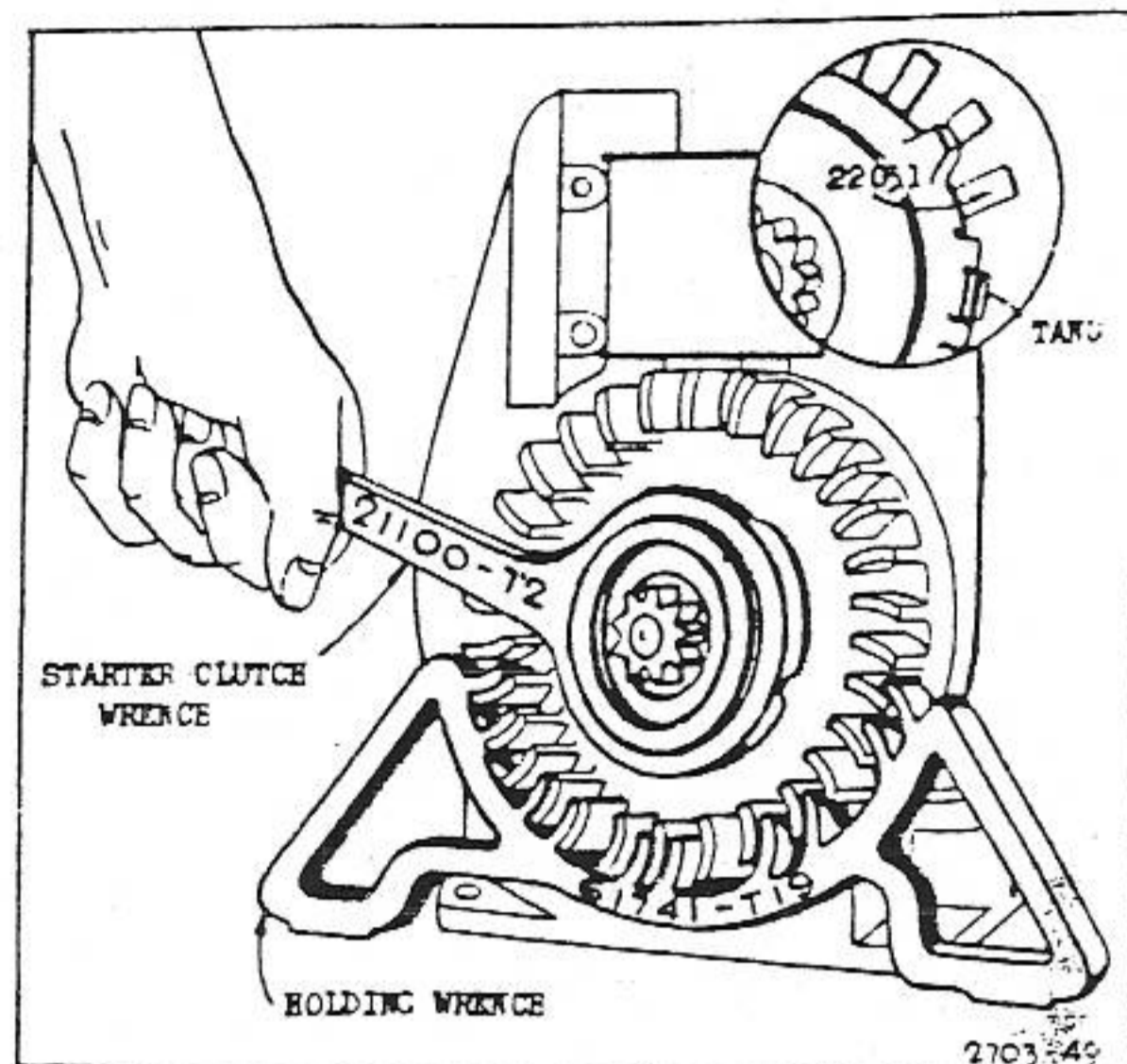


FIG. 11 — REMOVING FLYWHEEL

**Models 9-14-23**

Assemble flywheel with starter pin in 10:30 o'clock position as shown in Fig. 12. This will bring starter crank in bottom position for easy starting. This setting may be changed if the owner desires a different starting position.

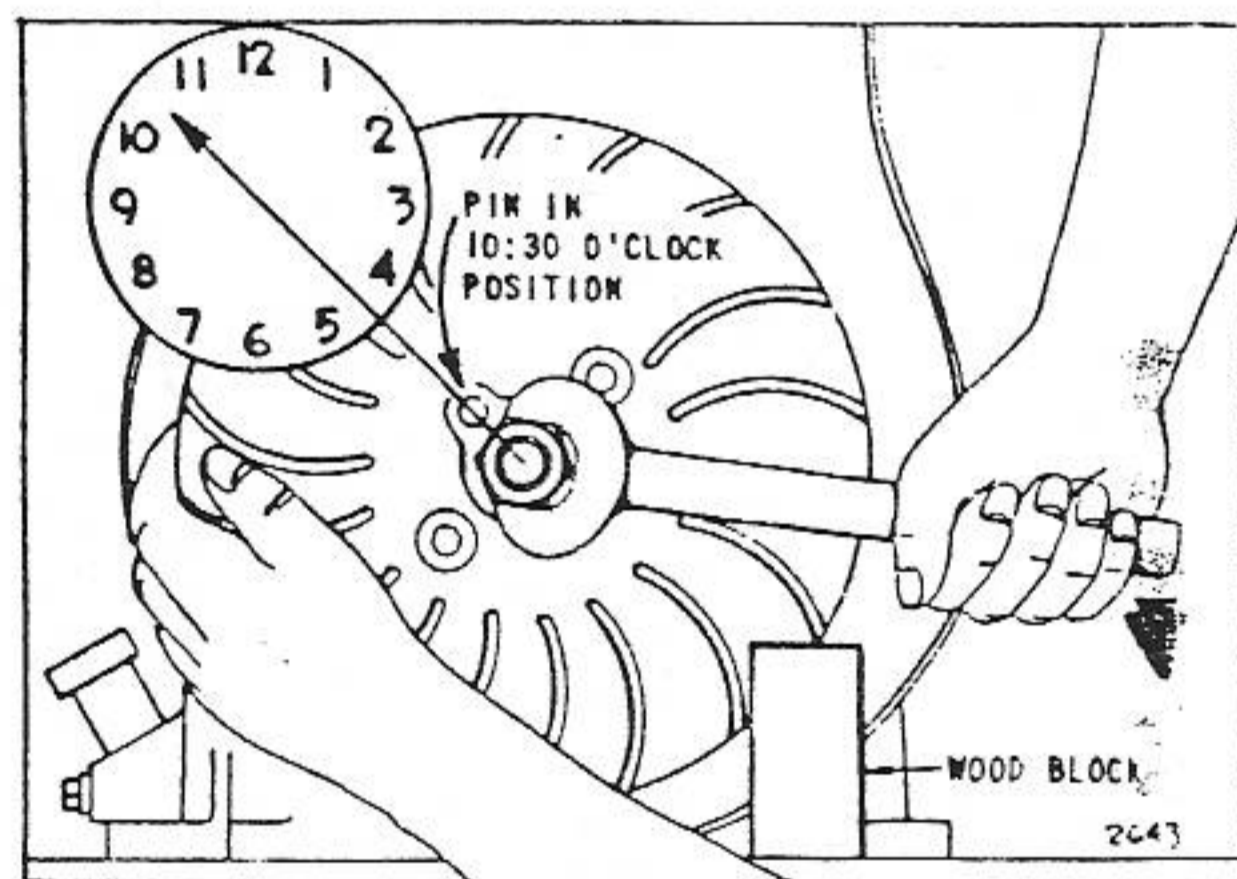


FIG. 12 — ASSEMBLING FLYWHEEL

**Models H-Y**

Reverse removal operations but be sure the head of bolt goes on the side of flywheel with the high shoulder.

**To Repair Flywheel Mounting Hole on Models H-Y**

If the crankshaft extension is more than .001" undersize or less than the low limit of .936" on 75% of its surface, the crankshaft must be replaced with a new one. A loose flywheel fit on a new crankshaft also indicates flywheel replacement is necessary.

To check bolt hole, file roughness from both edges of bolt hole in crankshaft. Insert new flywheel bolt in crankshaft bolt hole before the flywheel is mounted. If the bolt enters bolt hole with either a press or slip fit (without side play) it is not necessary to ream bolt hole. However,

if the flywheel bolt hole in the crankshaft is worn egg-shaped, or if bolt fits loosely, the hole in both flywheel and crankshaft must be reamed oversize for oversize bolt No. 91681. To do this, assemble retainer clip and flywheel to crankshaft and ream all holes in one operation as shown in Fig. 13. The latest type oversize flywheel bolt No. 91681 has an O. S. stamped on its head. The early type can be identified by the painted red head. If an oversize bolt is loose, worn parts must be replaced.

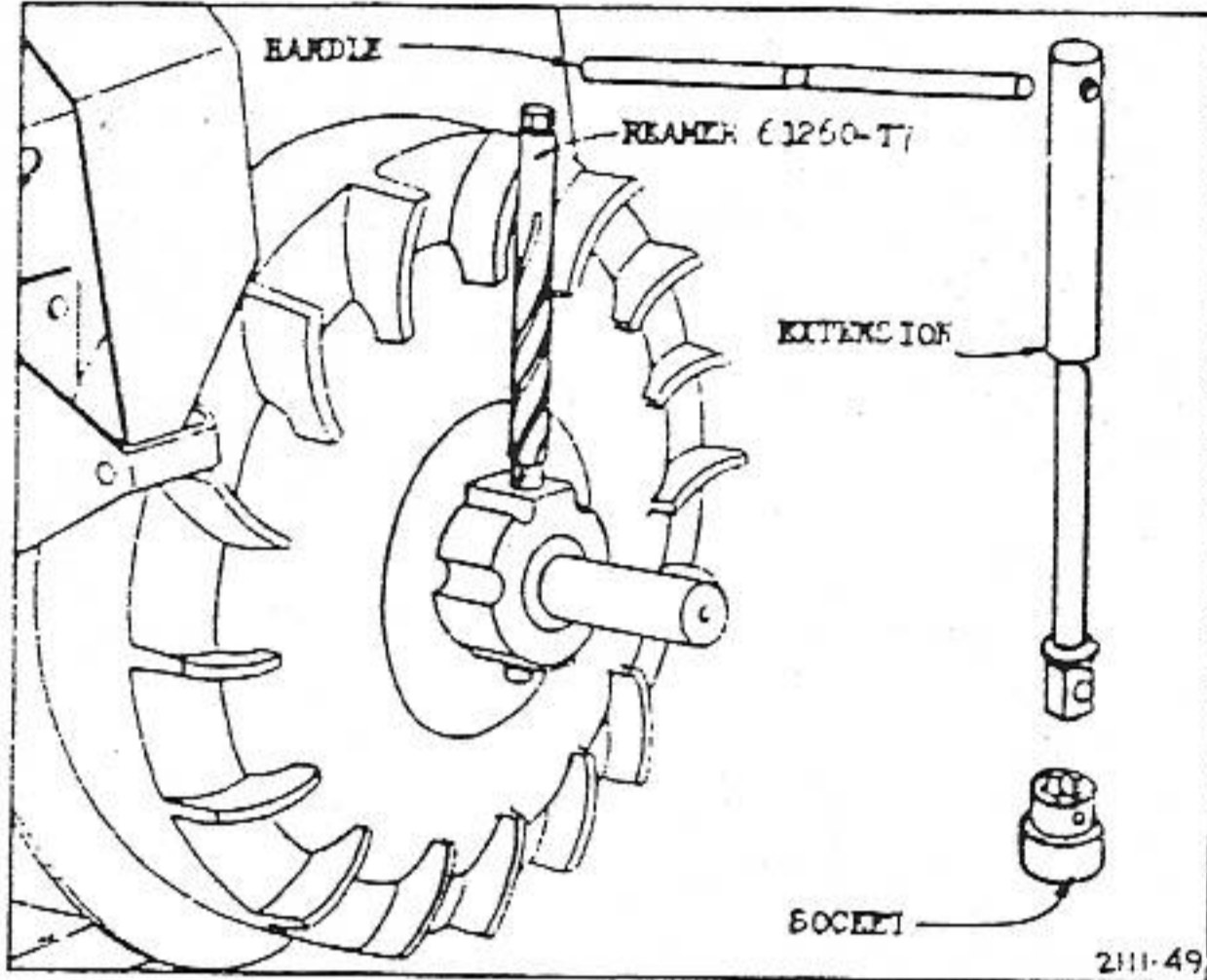


FIG. 13 — REAMING FLYWHEEL HUB

### IGNITION CABLE

The ignition cable must not be oil soaked, deteriorated or broken. These conditions will ground the spark. The end of the cable must be securely bent around the high tension terminal of the coil, but should *not* be soldered to the terminal.

#### Models 9-14-23

The cable on these models is a part of the coil and cannot be removed. Should the terminal break off, the cable is long enough to replace with a new terminal.

### MAGNETOS USED ON MODELS A-B-H-K-Y-Z-ZZ

#### To Adjust Breaker Points

Before adjusting the point gap, the points should be lined up squarely with the proper tension. Loosen the spring bolt and move point spring until points are aligned. Then retighten spring bolt. To adjust point tension, turn crankshaft until points open to widest gap. Loosen block screws and move the block until a  $1/16$ " gap is obtained between the breaker spring and the rounded end of the block. Fig. 14. Hold in this position while retightening block screws. This should give a point tension of 16 to 20 ozs.

Loosen the lock nut to adjust the breaker gap. Turn screw point until  $.020$ " gap is obtained, then retighten lock nut. Fig. 15.

#### To Replace Breaker Points

If either point is burned or pitted they should be replaced as a set. After parts are assembled they should be adjusted as shown in Fig. 15.

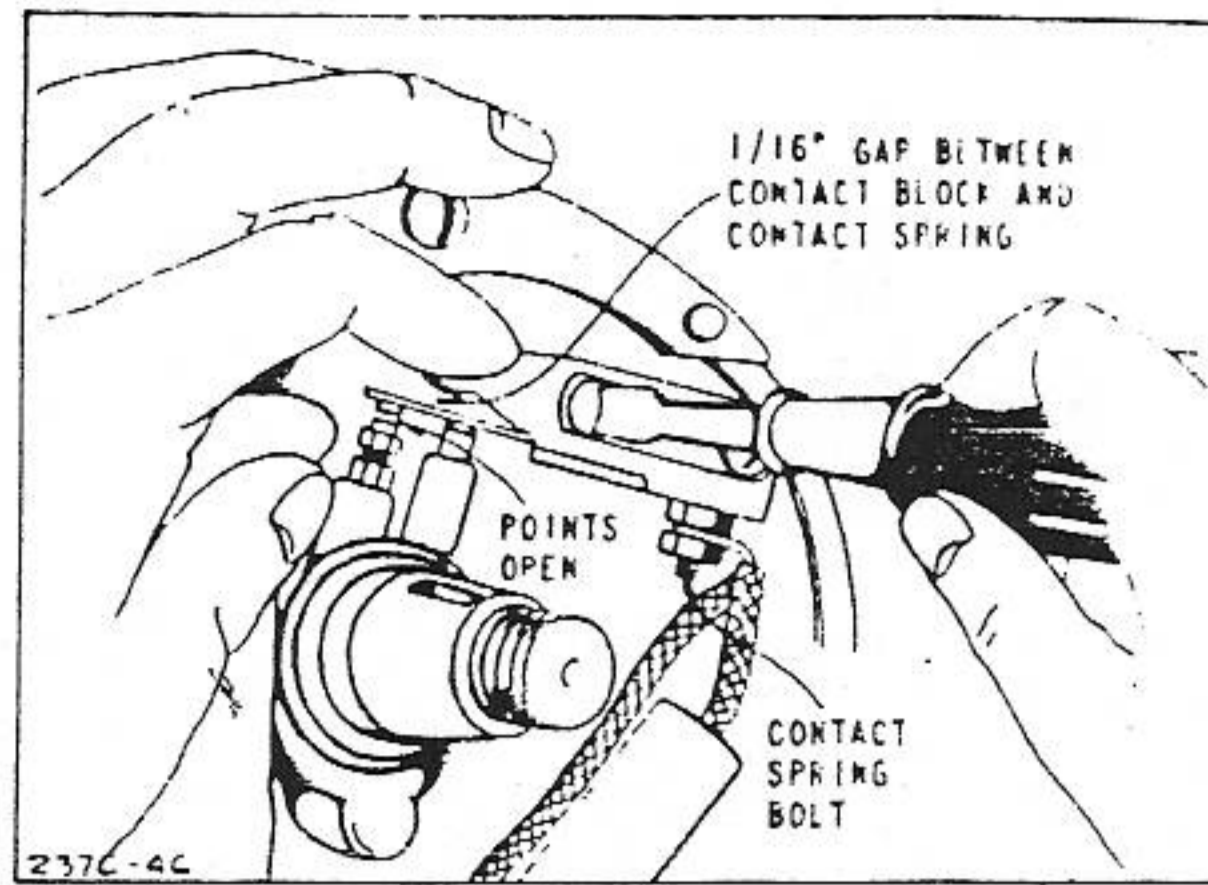


FIG. 14 — ADJUSTING POINT TENSION

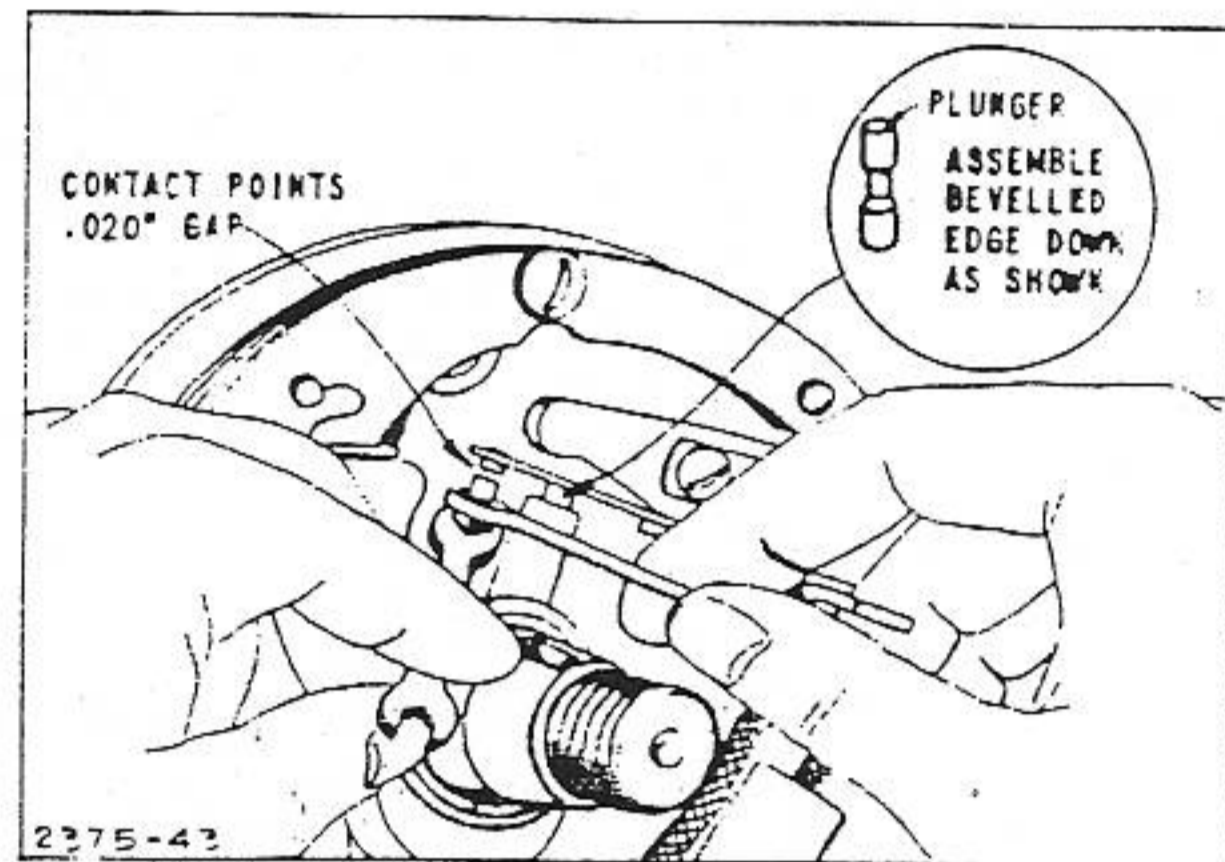


FIG. 15 — ADJUSTING BREAKER POINTS

#### To Check Breaker Plunger

Replace breaker plunger if a  $.020$ " point gap cannot be obtained.

#### To Replace Condenser

The condenser wire, and armature wire on older model engines were soldered to the breaker spring. On later models the wires are fastened by means of a clip assembled to the bolt. Fig. 16.

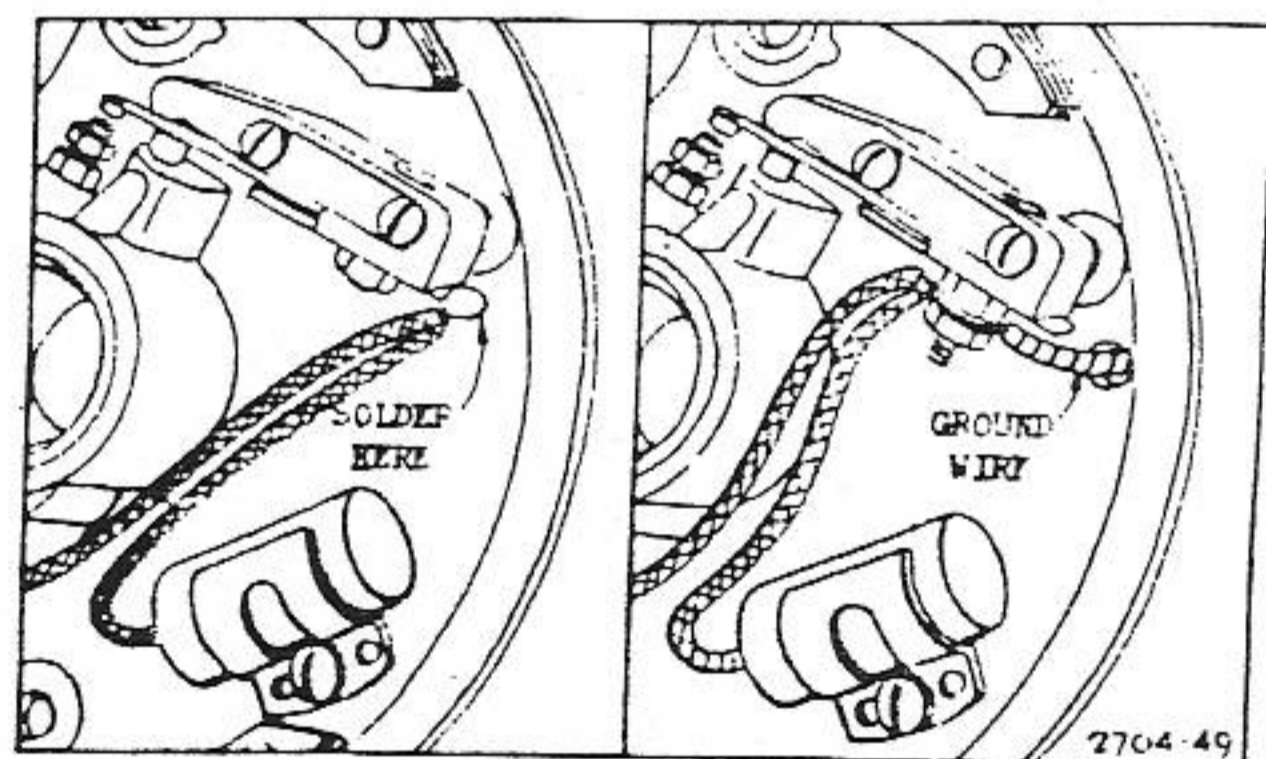


FIG. 16 — REPLACING CONDENSER

#### To Replace Armature

Remove armature wire from breaker spring, and ignition cable from secondary terminal in coil. Unscrew the two armature mounting screws and pry armature loose with a screw driver. Mount new armature in same position as the old one and tighten in place with two mounting

screws. Fasten armature wire to breaker point. Push end of ignition cable through terminal on coil and bend wire firmly with needle-nose pliers. Fig. 17.

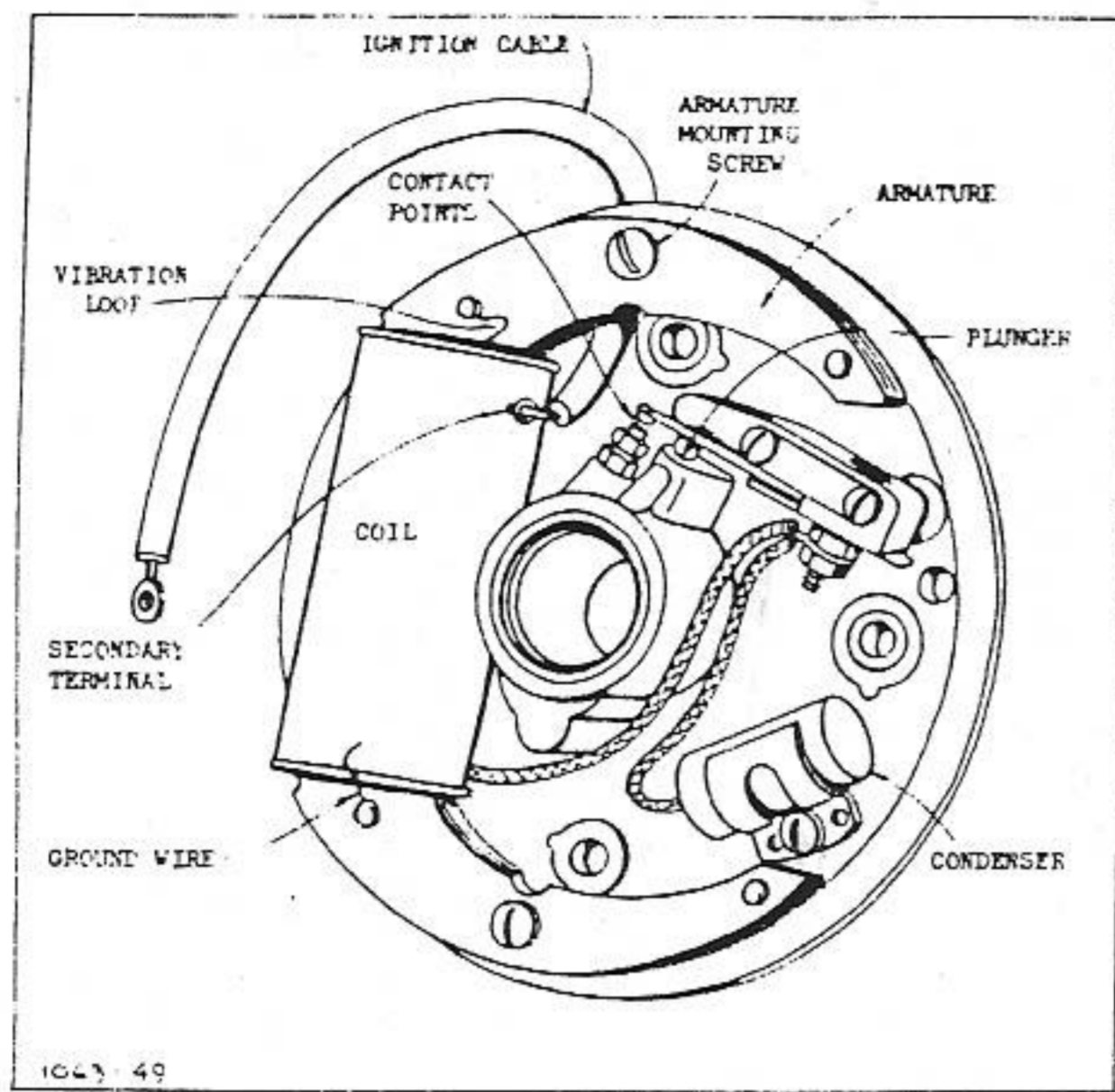


FIG. 17 — REPLACING ARMATURE

**To Check Breaker Plunger Hole**

The breaker points and plunger must be removed in order to check the plunger hole. If the flat end of plug gauge No. 69821-T3-32 will enter, the hole is worn and a bushing No. 63709 should be installed. Fig. 18.

**To Install Breaker Plunger Bushing**

Remove oil valve from magneto plate. Remove contact block assembly, then loosen armature screws and pull armature away from the magneto plate. Ream plunger hole with reamer No. 69821-T3-2. Reaming can be done by hand or in a drill press. It is important that the reamer follows the old hole. Fig. 18.

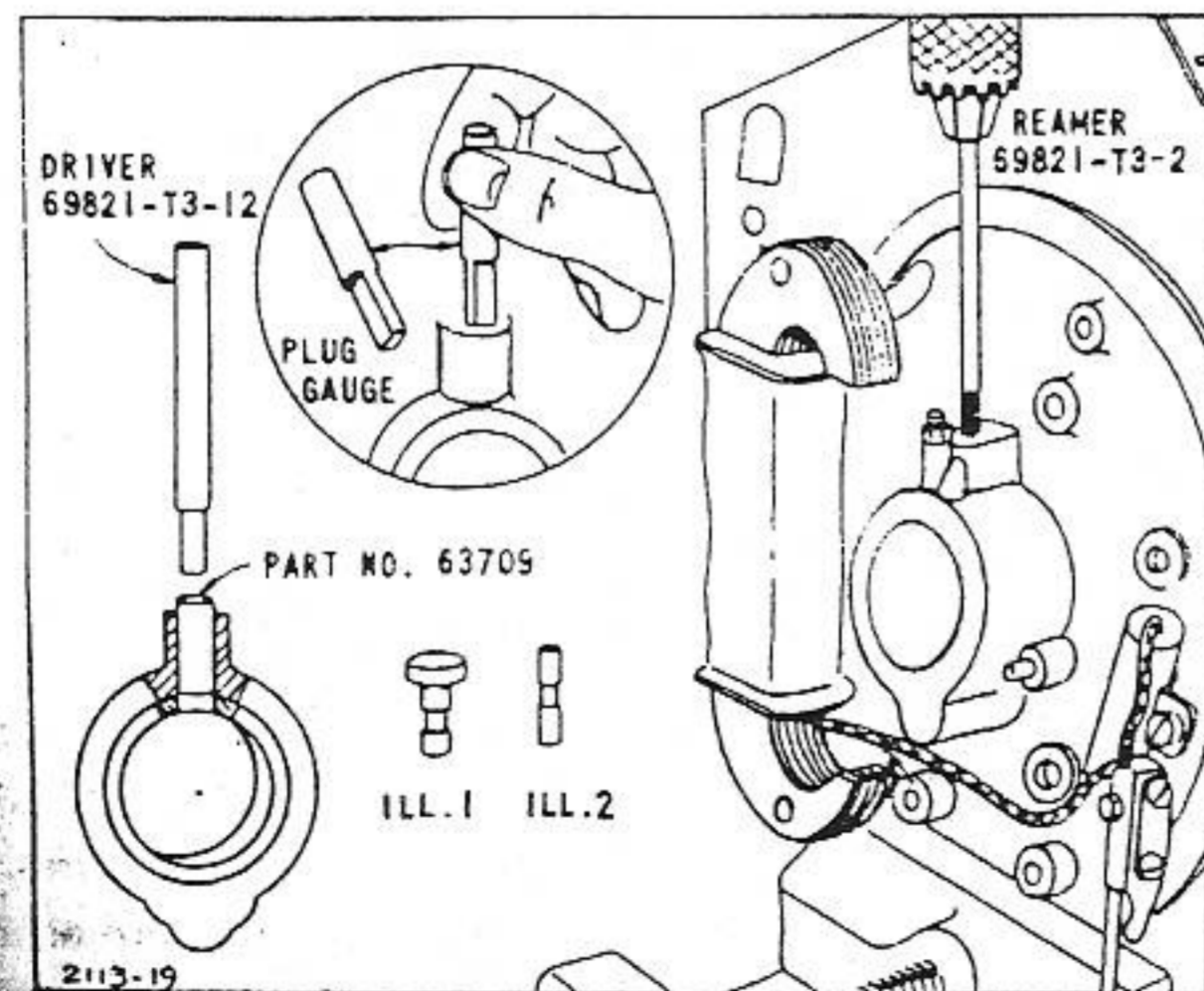


FIG. 18—INSTALLING BREAKER POINT BUSHING

After reaming, press in bushing No. 63709, using driver No. 69821-T3-12. When pressing the bushing, No. 63709, into the plunger hole, BE CAREFUL NOT TO PRESS THE PLUNGER BUSHING INTO THE MAGNETO BEARING, as this would cause oil pumping through

the plunger hole. On early models, bushing No. 63709 will extend  $\frac{1}{8}$ " above the boss in the magneto plate, but on the later models it will be even with the top of boss. On early models the boss is  $\frac{3}{8}$ " high. On late models the boss is  $\frac{1}{2}$ " high. Fig. 19.

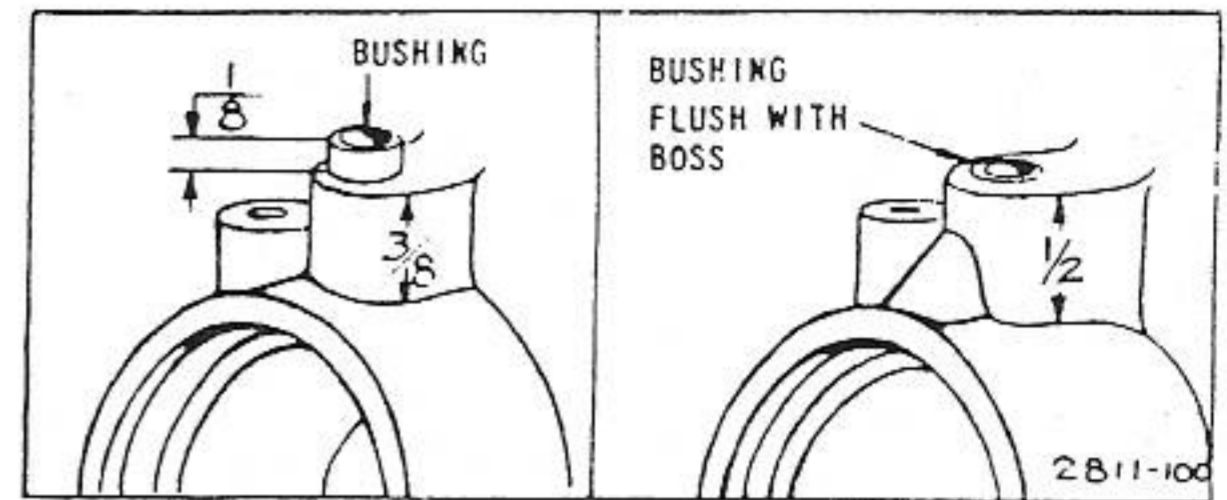


FIG. 19—INSTALLING BREAKER POINT BUSHING

On engines with vacuum breathers, a by-pass hole is provided which slants upward from the oil groove just inside the oil retainer to the contact plunger hole. Fig. 20. After a new bushing has been installed, this hole must be drilled out with a  $\frac{5}{32}$ " drill before bushing is reamed. After bushing No. 63709 is in place, it must be reamed with a reamer, No. 69832-T3-22, to assure a free fit for the contact plunger. Before reassembling magneto plate to engine, be sure the oil return hole and bearing is clean and the oil valve is in working order. Assemble point plunger with the bevelled edge at the recess down. Fig. 20. Discard old style plunger and replace it with No. 65414 new style plunger.

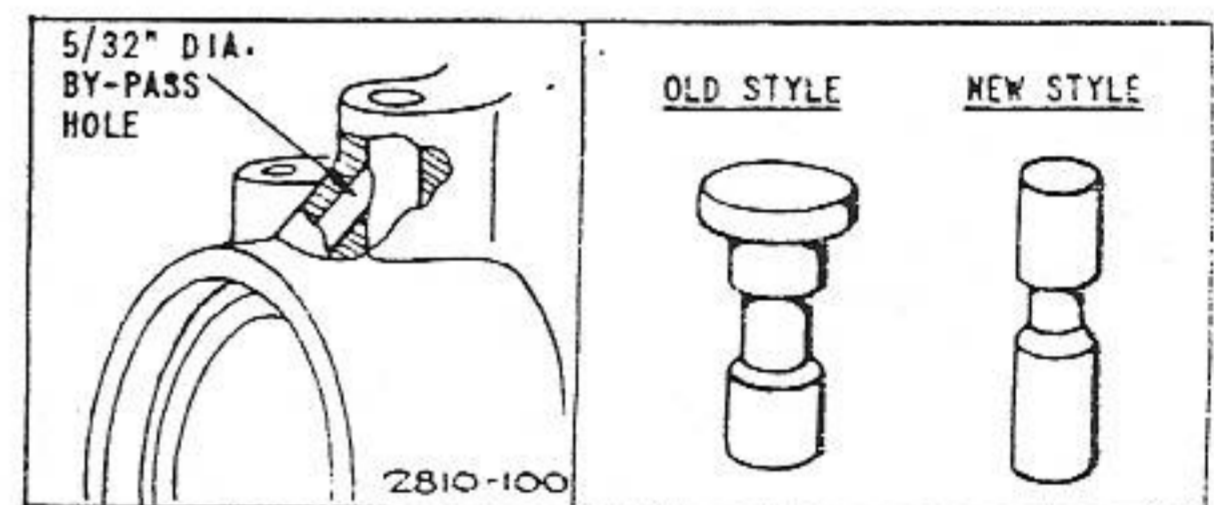


FIG. 20—INSTALLING BREAKER POINT BUSHING

**To Remove Breaker Plunger Bushing**

If the magneto plate has been repaired and a plunger bushing installed, or if originally equipped with bushing, it will be necessary to turn driver No. 69821-T3-12 as shown in Fig. 21. The driver may then be used either to remove the old bushing or insert the new one. However in this case, care must be taken not to drive the new bushing in too far.

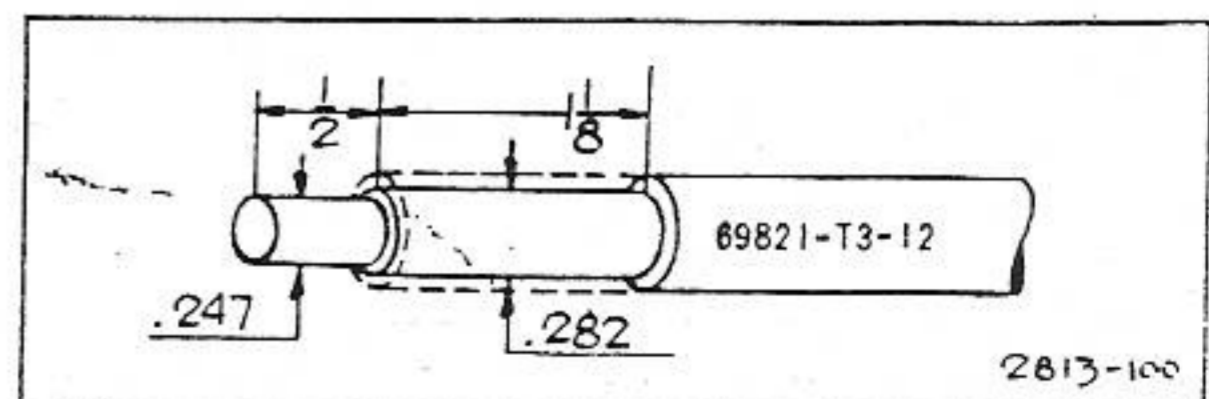


FIG. 21—CONVERTING DRIVER

**To Replace Ignition Cable**

Assemble No. 66128 rubber washer to ignition cable so it will be against the magneto plate on the outside. Fig. 22, Ill. 3. This is to prevent water from entering the

another free manual from www.searstractormanuals.com

magneto. Push ignition cable through the hole in magneto plate. Loop end of cable through hole in terminal on coil, then bend wire with pliers until it is securely fastened to the terminal. DO NOT SOLDER. Fig. 22, Ill. 2.

NOTE: On ignition cables with shielding, the rubber washer No. 66128 is assembled to cable at inside end. Fig. 22, Ill. 1. If ignition cables are made from spool stock, the end attached to coil should be tinned before assembly so that it will be stiff enough to hold firmly to terminal.

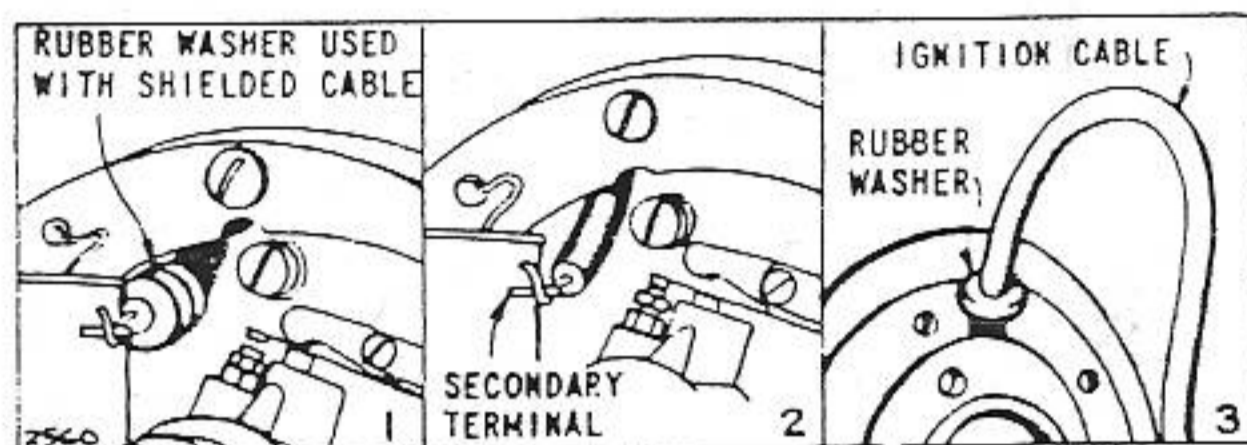


FIG. 22—REPLACING IGNITION CABLE

### To Time Magneto

The magneto is always correctly timed when the flywheel is properly assembled. Do not attempt to change timing by re-locating any parts or filing the crankshaft flat.

### To Adjust Armature Air Gap

Chalk edges of armature laminations and mount flywheel in place. Turn flywheel several revolutions by hand. Remove and examine edges of armature laminations. The high spots will have chalk marks rubbed off. Loosen the mounting screws very slightly, tap the high side lightly to center the armature, then re-tighten the mounting screws. Fig. 23.

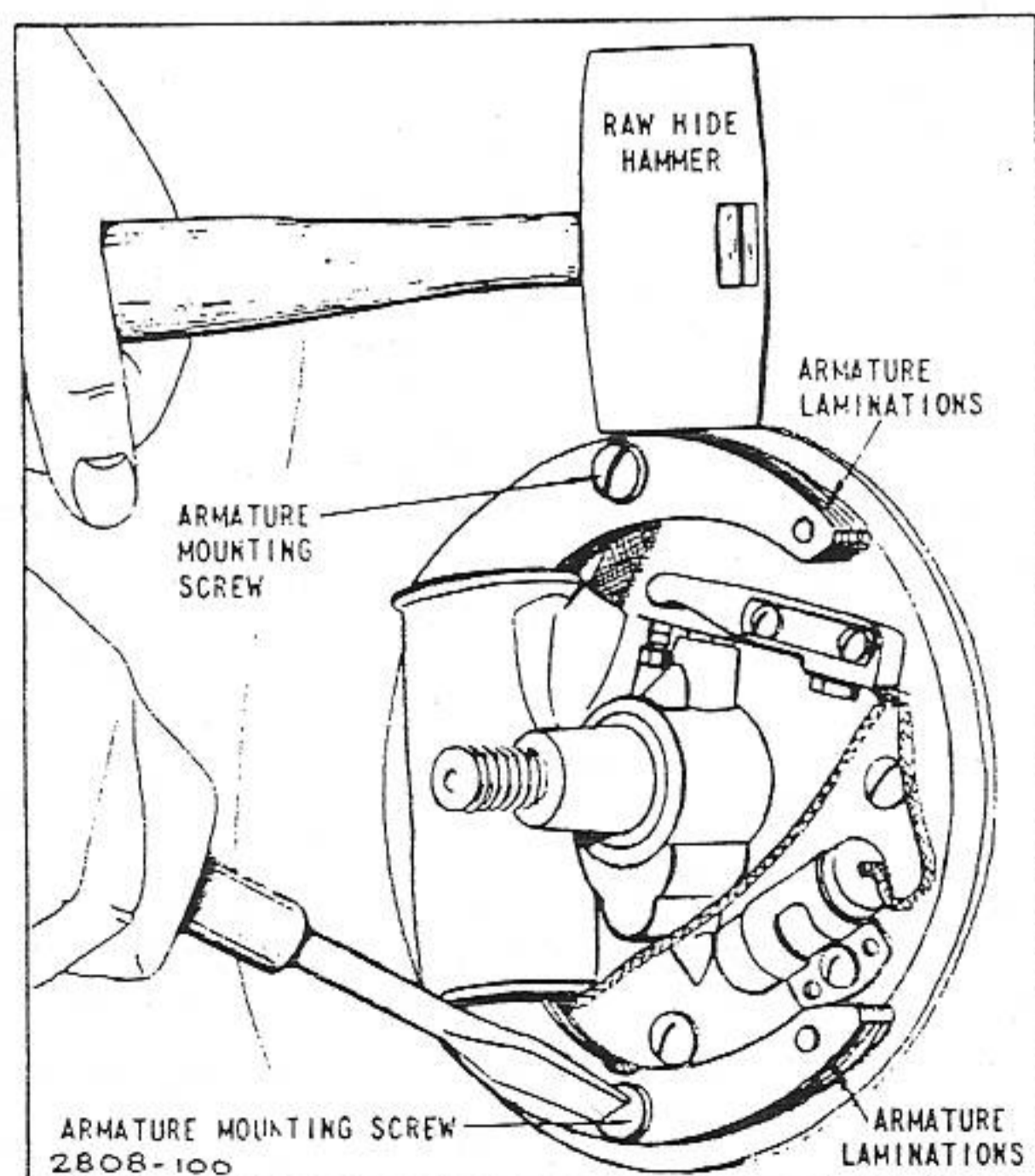


FIG. 23—ADJUSTING ARMATURE AIR GAP

## MAGNETOS USED ON MODELS FH-FI-FJ-L-M-PB-Q-R-S-T-W

### To Adjust Breaker Points

Turn crankshaft until points open to widest gap. Loosen contact bracket screw, then move contact bracket to or from breaker arm point until a point gap of .020" is obtained. Fig. 24.

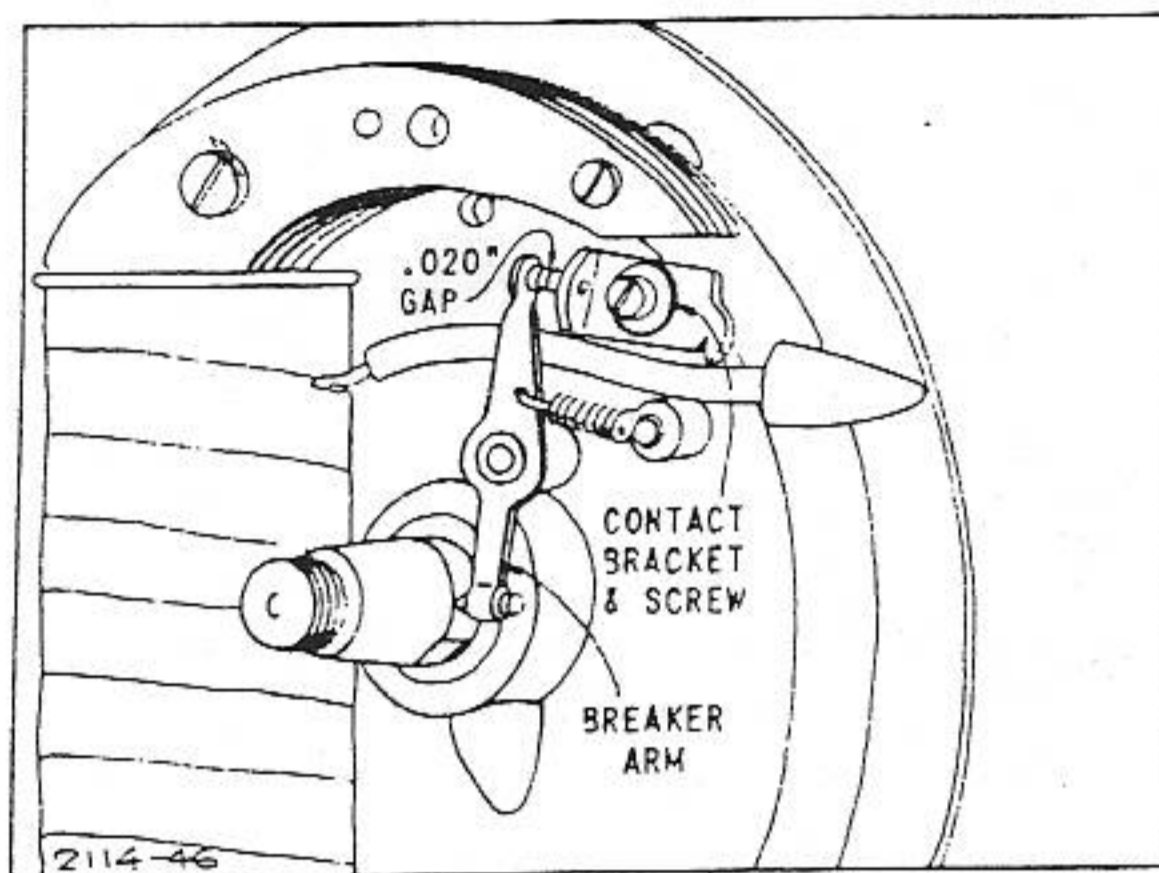


FIG. 24—ADJUSTING BREAKER POINTS

### To Replace Condenser

Remove old condenser by unsoldering condenser wire. If primary wire is loosened, it should be resoldered with new condenser wire. Fig. 25.

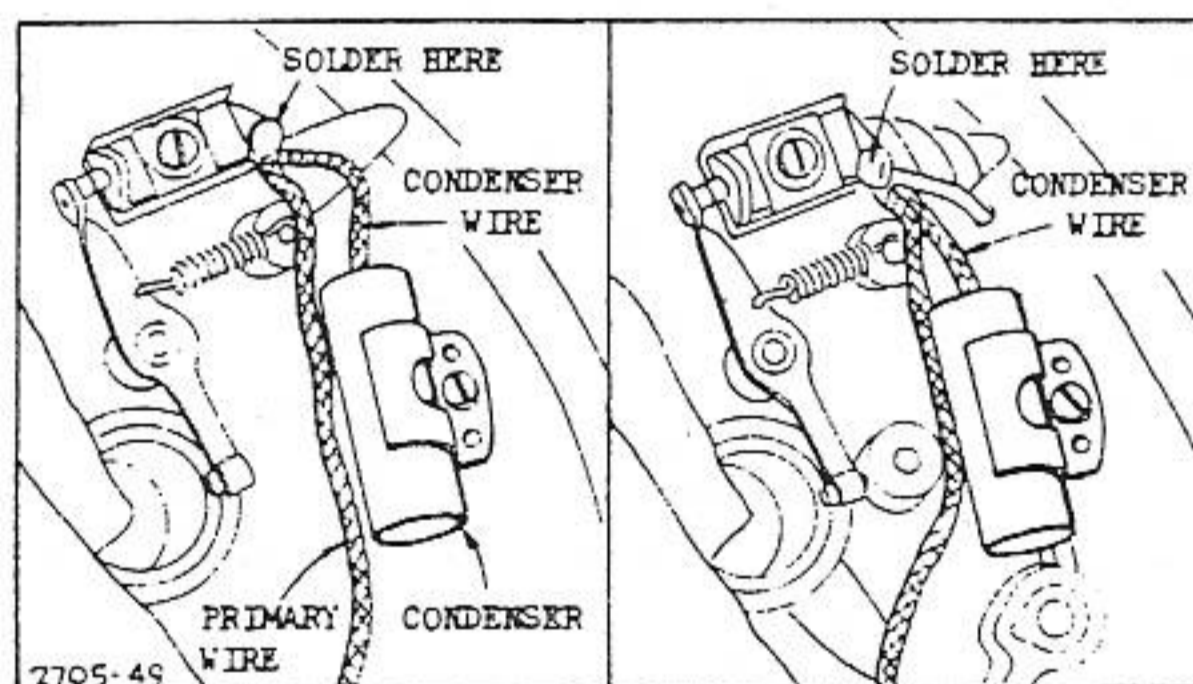


FIG. 25—REPLACING CONDENSER WIRE

### To Replace Armature

Remove armature lead wire from contact bracket. Remove the ignition cable from the terminal on the coil. Unscrew four armature mounting screws. Hold magneto plate and pry armature loose with a screw driver. To test coil be sure to fasten both secondary ground wire loops (A and B) to the core. Fig. 26. The secondary of this coil is split and the ground wires are not connected inside of the coil. Failure to fasten either or both of these ground wires will result in a weak or dead coil. Mount armature on the two locating pins as shown in Fig. 26. Fasten armature to plate with four mounting screws—with two screws next to coil end inserted in loop A and B. Fasten ignition cable to terminal of coil. Dirt under the stop button spring in blower housing, or on air guide in some models, will cause a short. Check and clean.

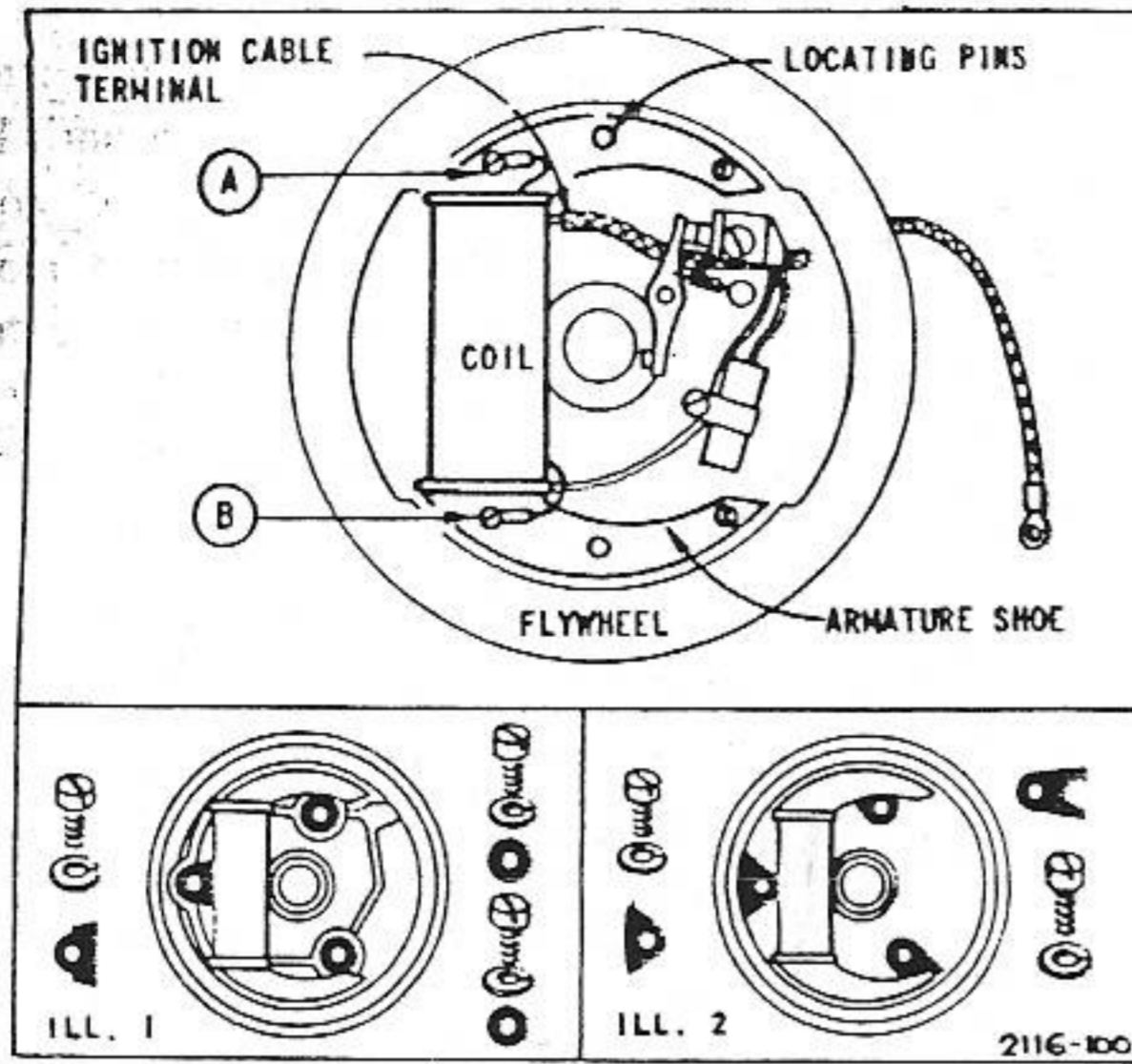


FIG. 26—REPLACING ARMATURE

EARLY MODEL FH engines were not equipped with steel locking plates under mounting screws and lock washers of magneto plates. This caused screws and lockwashers to become loose and damaged the magneto. On magneto plates with reinforcing rib as shown in Fig. 26, Ill. 1, use locking plate assembly No. 69711. On plates without enforcing rib, use assembly No. 69712. See Fig. 26, Ill. 2.

**To Replace Ignition Cable**

Push ignition cable through hole in magneto plate. Loop end of cable through hole in terminal on coil, then bend wire with needle-nose pliers until it is firmly fastened to the terminal. DO NOT SOLDER.

**To Time Magneto**

With contact points at .020" gap, insert flywheel key in shaft and securely mount gauge No. MPJ-T4 on crankshaft. Place .003" feeler between contact points and move crankshaft clockwise until point closes, then open to .003" gap. If the pointer of gauge lines up with the end of the armature shoe, as shown in Fig. 27, Ill. 1, timing is correct. If the pointer is past the armature shoe as shown in Ill. 2, the timing is late. To correct, install a new fibre tip, No. 65014, on breaker arm and recheck. If pointer is ahead of the end of the armature as shown in Ill. 3, file bevel of fiber tip until the pointer lines up with end of shoe.

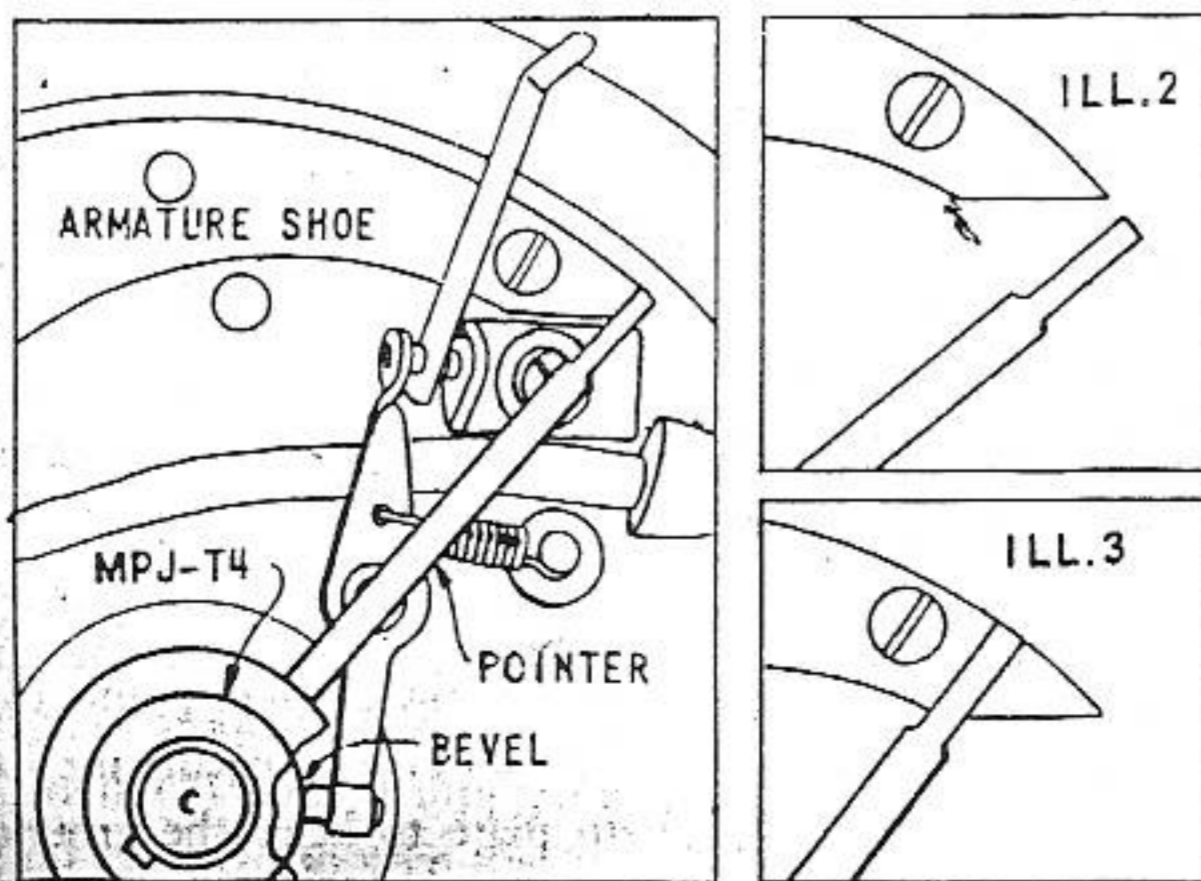


FIG. 27—TIMING MAGNETO

**To Adjust Armature Air Gap**

Chalk edges of armature laminations and mount flywheel in place. Turn flywheel several revolutions by hand. Remove flywheel and examine edges of flywheel laminations. The high spots will have chalk rubbed off. File these high spots carefully until rub is eliminated.

**MAGNETOS USED ON MODELS I-N-NS-U-WI-WM-WMB-WMI-5-6-8**

**To Adjust Breaker Points**

Turn crankshaft until points open to widest gap. Loosen adjusting lock screw and move contact point bracket up or down to obtain .020" gap. Tighten adjusting lock screw. Fig. 28. Turn crankshaft so that contact points are closed. Twelve to sixteen ounce tension should open the points. If spring tension is too weak, bend contact spring tang to get proper tension.

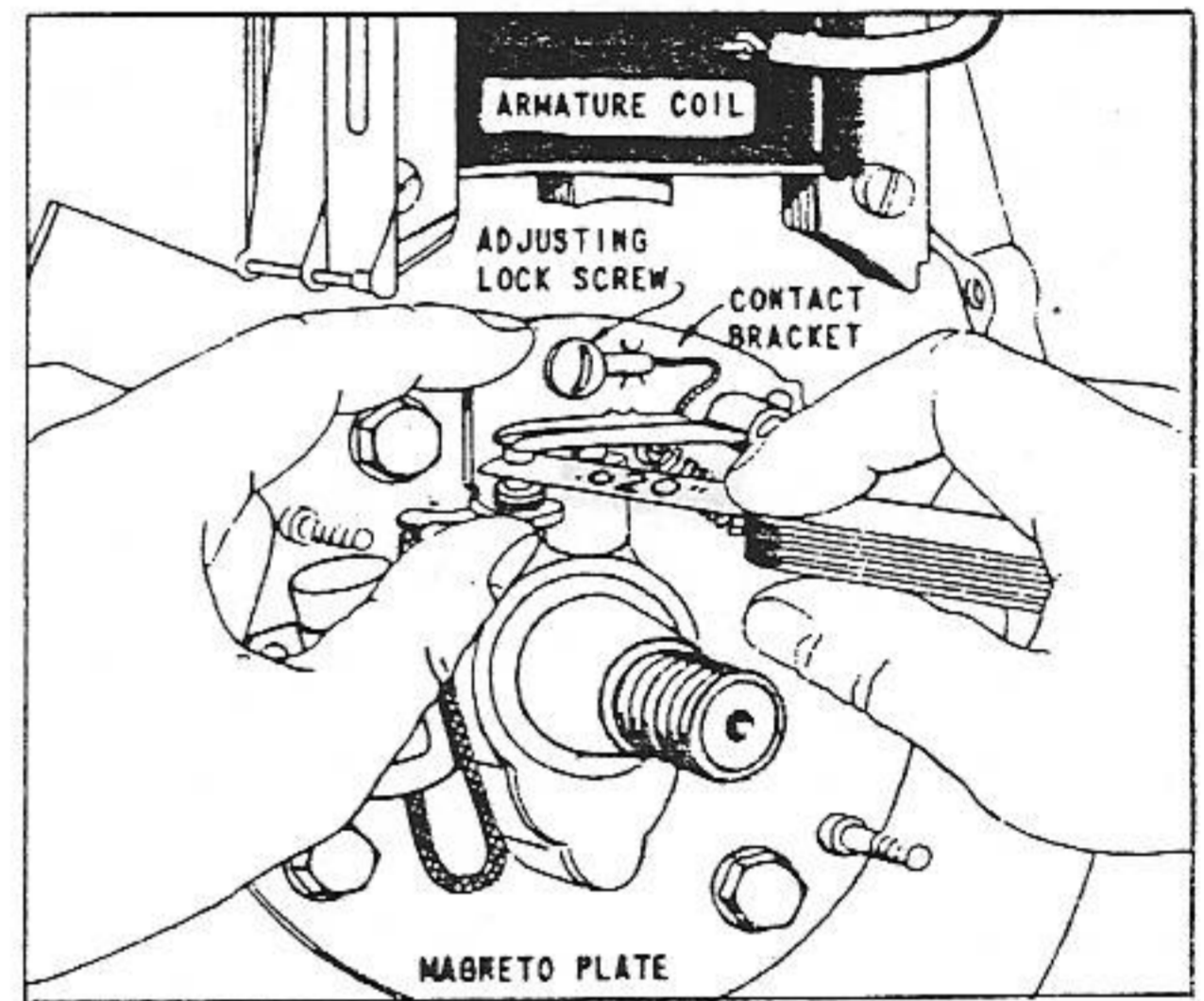


FIG. 28—ADJUSTING CONTACT POINTS

**To Replace Breaker Points**

Loosen condenser and armature wires from breaker point tang. Loosen adjusting lock screw and remove breaker point assembly. To assemble, place the varnished insulator used with the new style points beneath the point bracket.

The small boss on magneto plate should protrude through the small hole in insulator and enter the hole in the point bracket. Fig. 29. If a small insulator is fastened to the clip, the cambric insulator is unnecessary.

Fasten the condenser and armature wires to the breaker points with the clip and screw. The clip must not touch the condenser, or the ends of the wires touch the bracket as this will short the circuit.

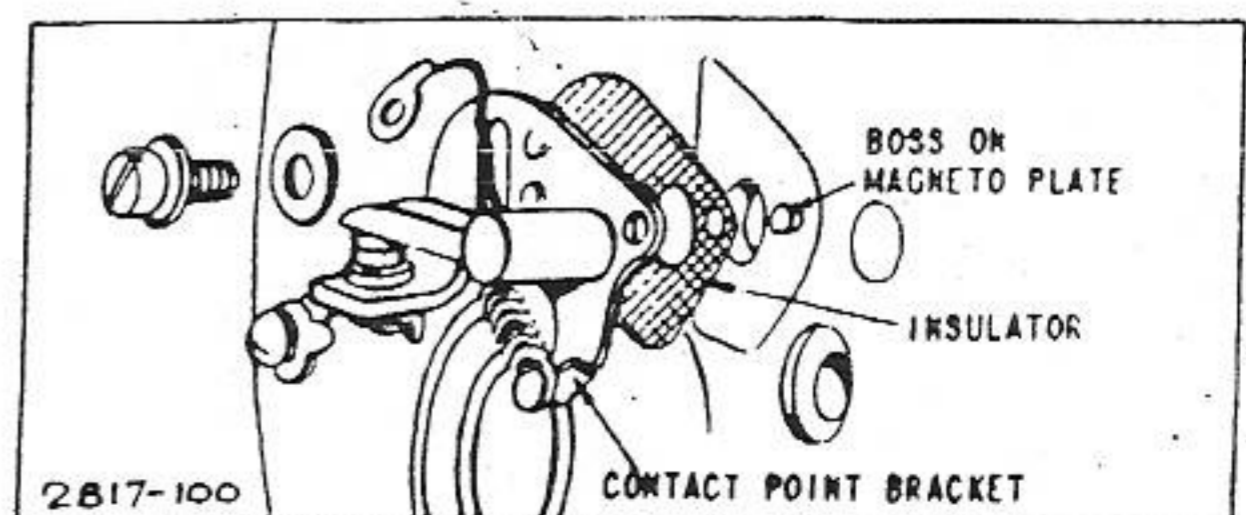


FIG. 29—REPLACING BREAKER POINTS

another free manual from www.searstractormanuals.com

### To Check Breaker Plunger

If the breaker plunger is so short that a .020" point gap cannot be obtained, the plunger should be replaced with a new one.

### To Replace Condenser

On older models the condenser wire is soldered to the brass tang on the point bracket. On later models the condenser wire is fastened to the point bracket by means of a clip and screw. Fig. 30.

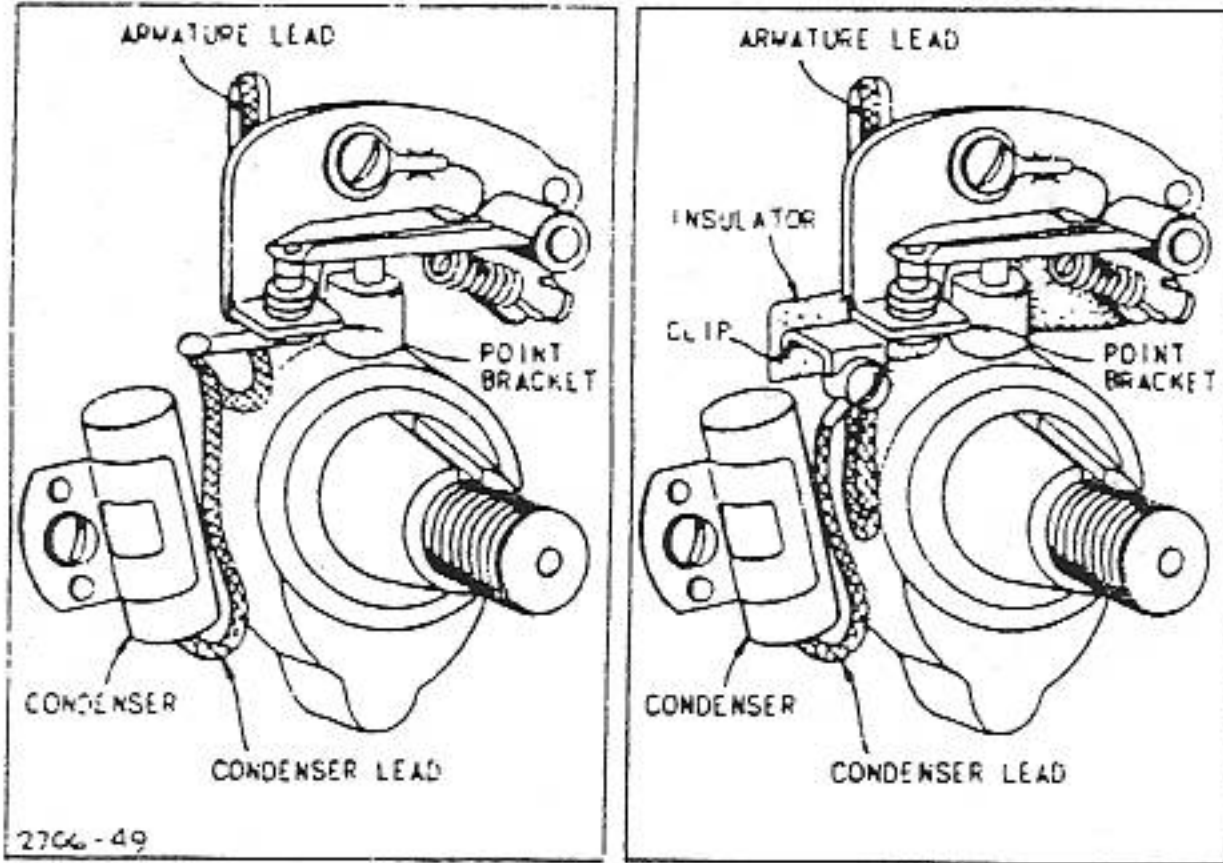


FIG. 30—REPLACING CONDENSER

### To Replace Armature

Remove armature lead wires, ignition cable, four armature mounting screws, lockwashers, and plain washers. To replace, reverse operation. Fig. 31. Be sure to adjust air gap after flywheel is assembled.

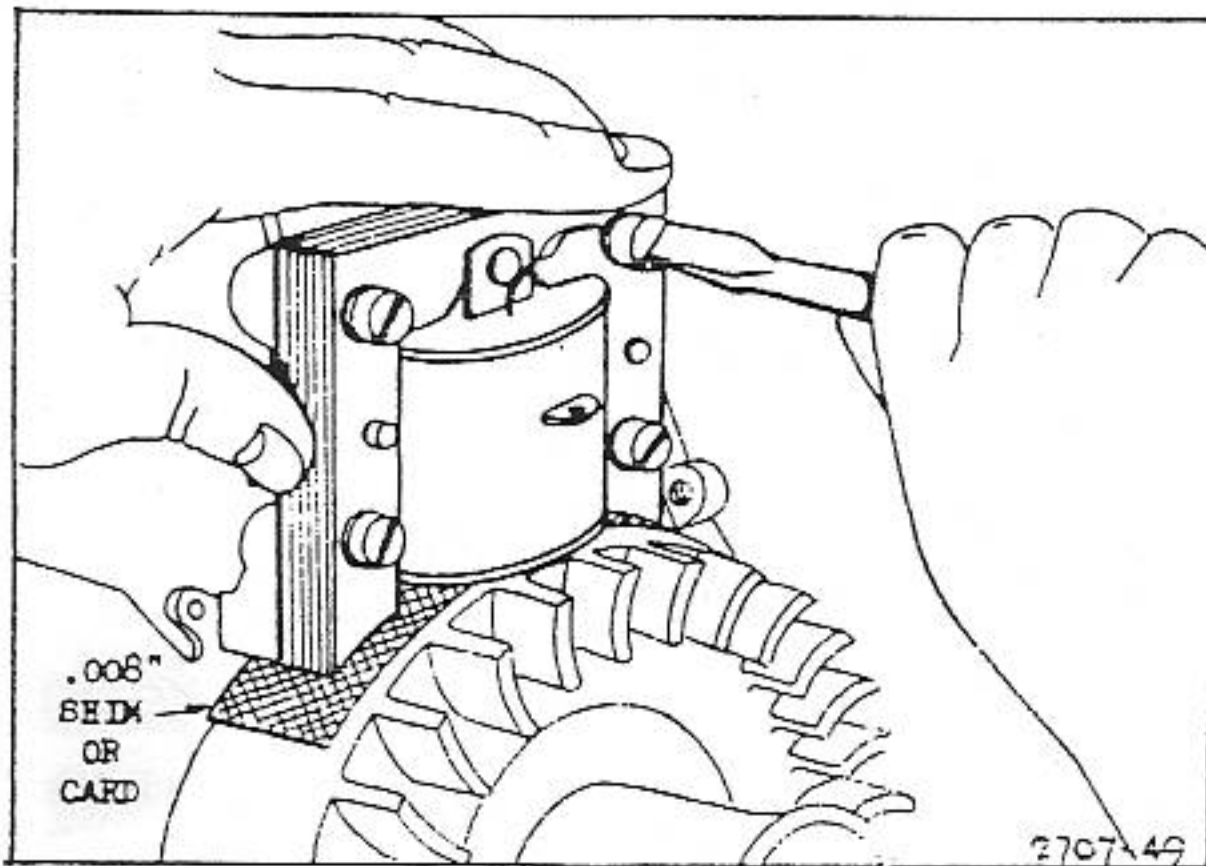


FIG. 31—REPLACING ARMATURE

### To Check Breaker Plunger Hole

The breaker points and plunger must be removed in order to check the plunger hole. If the flat end of plug gauge No. 29673-T10 will enter, the hole is worn and a new bushing No. 23513 should be installed. Fig. 32.

### To Install Breaker Plunger Bushing

To rebush the plunger hole, it is necessary that the magneto be removed and that the armature, breaker points, and oil return valve (if there is one) be removed from the magneto plate.

Place reamer, No. 29673-T10-2 in a drill press chuck. Lift magneto plate until the pilot on the end of the reamer enters the plunger hole to be sure that the reamer is prop-

erly aligned with the old hole. Holding the magneto plate in this position, bring the drill press down until bottom of magneto plate touches the drill press table. To check for vertical alignment, see that the armature mounting bosses are equal distances from the reamer. Start drill press and ream hole. Use tool No. 29673-T10-12 to drive the bushing (part No. 23513) into the hole until the top of bushing is flush with top of hole. Fig. 32. Use reamer No. 29673-T10-22 to finish-ream the bushing to size for plunger. The finish reaming should be done by hand.

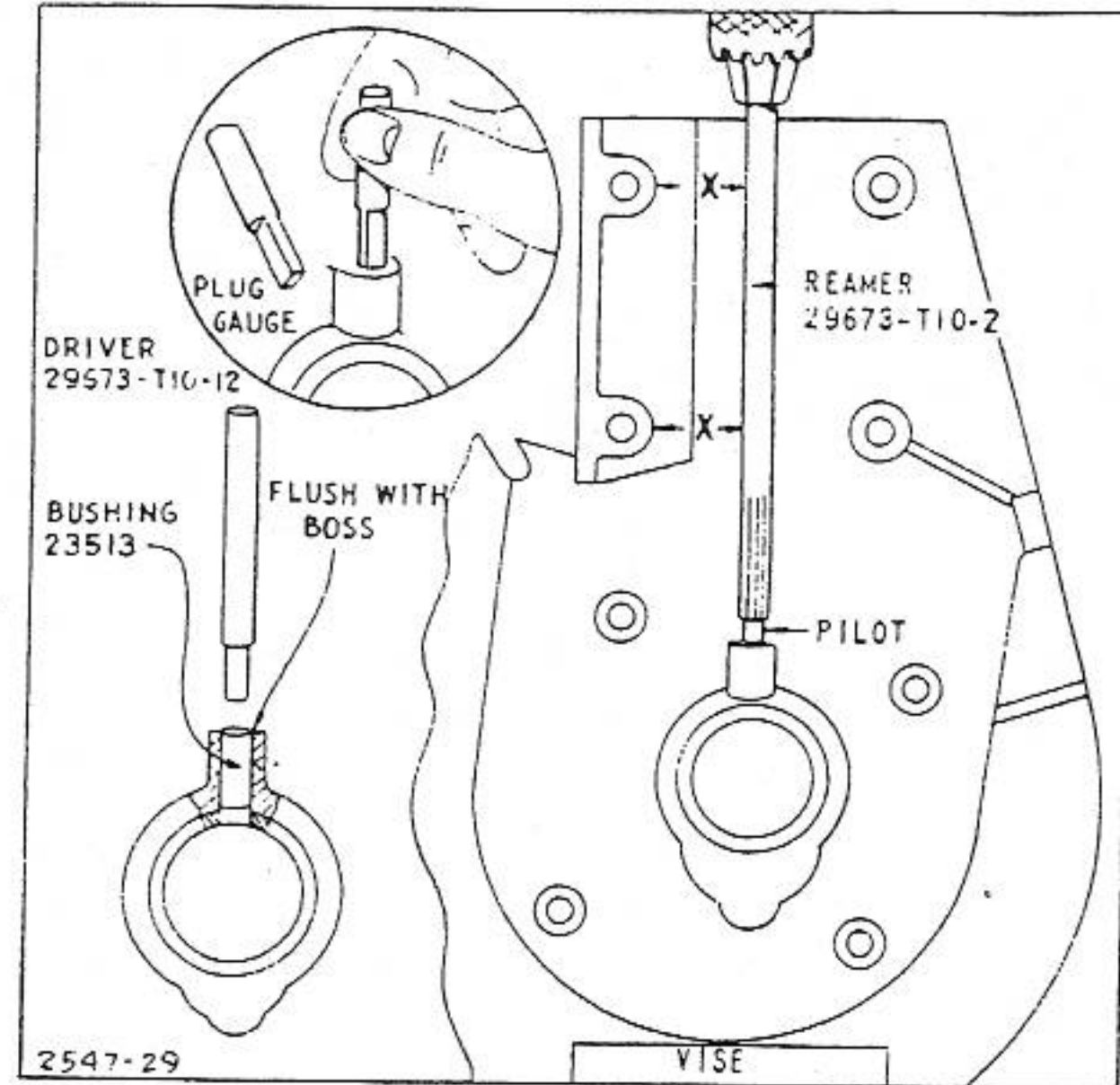


FIG. 32—INSTALLING BREAKER PLUNGER BUSHING

### To Remove Breaker Plunger Bushing

If the magneto plate has been repaired and a plunger bushing installed, or if originally equipped with bushing, it will be necessary to turn driver No. 29673-T10-12 as shown in Fig. 33. The driver may then be used either to remove the old bushing or insert the new one. However, in this case, care must be taken not to drive the new bushing in too far.

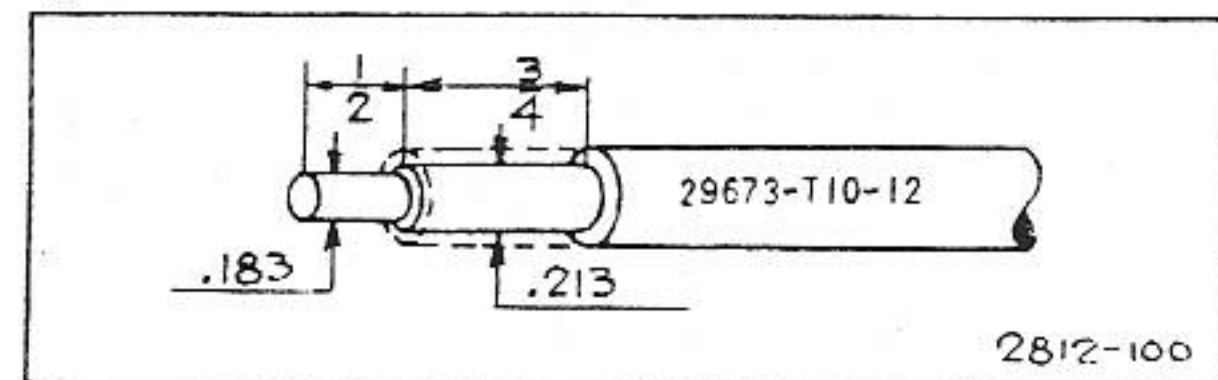


FIG. 33 — CONVERTING DRIVER

### To Replace Ignition Cable

Loop end of cable through hole in terminal on coil and bend wire with pliers until it is securely fastened to the terminal. DO NOT SOLDER.

### To Replace Ground Wire

The ground wire is fastened to the breaker points together with the condenser wire. A flat clip is usually used on the back side of the magneto plate to keep the ground wire from pulling out. If this clip is not available, a knot can be tied in the ground wire just inside the magneto plate.

**To Time Magneto**

The magneto is always correctly timed when the flywheel is properly assembled. Do not attempt to change timing by relocating any parts or filing crankshaft flat.

**To Adjust Armature Air Gap**

The air gap between flywheel and armature should be from .002" to .012". A badly worn magneto bearing may cause this gap to decrease when the engine is running. Turn flywheel until magnets are directly below the armature laminations. Raise armature and insert a strip of .008" brass shim stock, or Instruction Tag No. Ms-1342 (supplied with new armatures) between the end of the armature laminations and the flywheel magnets. Press armature down and tighten mounting screws. Pull shim out. Fig. 31.

NOTE: If a detached magneto assembly has been repaired, tag No. MS-1342 should be sent to customer with the magneto. This will instruct the customer on how to adjust the armature air gap on his own engine.

**MAGNEMATIC IGNITION USED ON MODELS 9-14-23**

This ignition system combines the best features of both the flywheel magneto and the external magneto ignition systems.

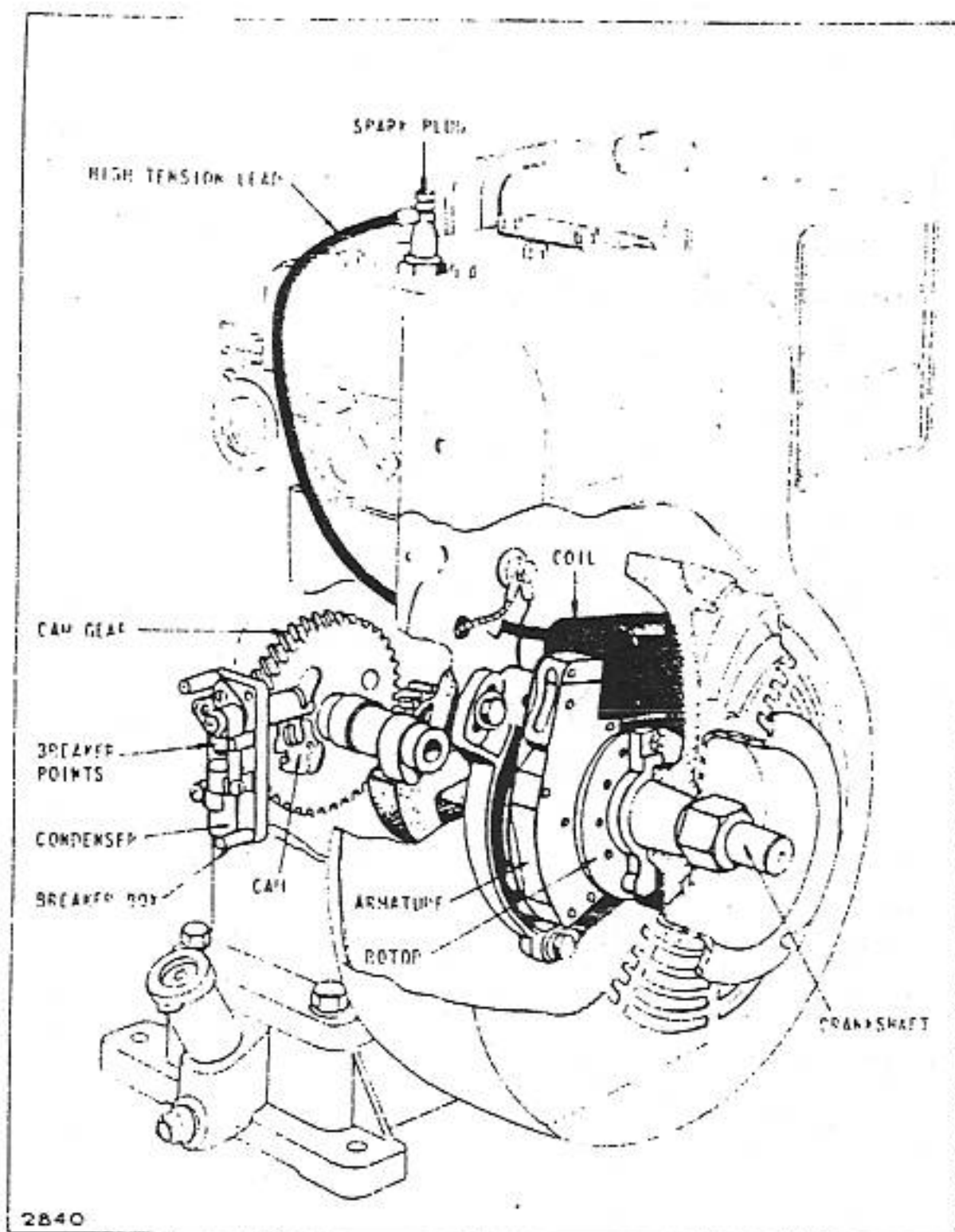
The magnetic rotor, the armature and the coil are mounted between the flywheel and the crankcase. The magnetic rotor uses Alnico magnets and therefore does not require periodic recharging. The coil is impregnated with and molded in a plastic jacket which makes it permanently waterproof. The high tension lead is molded into this jacket to prevent leakage where it connects to the coil, and is of sufficient length to permit replacement of spark plug terminal.

The Breaker Points, which require periodic inspection or adjustment, are mounted in a small box on the outside of the crankcase. This box also contains the condenser. The breaker points are actuated by a cam on the main camshaft gear in the crankcase and are adjusted by a cam and screw lock. Breaker box also contains the connection used when a ground wire for remote Stop-Switch is required.

The spark is automatically retarded while starting, but as the engine speed increases, it is advanced by centrifugal action of the cam weight on the camshaft gear. This design provides proper spark advance at operating speeds without starting "kickback."

The Magnematic Ignition system uses "normally closed" breaker points rather than the conventional "normally open" points and thereby achieves better matching of magneto output to engine requirements. A good spark is obtained at very low speeds for starting but the voltage at operating speeds is not excessive.

A further advantage of the Magnematic Ignition System is that it produces one spark for each two revolutions of the crankshaft, again supplying the engine's requirements but no excess to shorten the spark plug life.



THE BRIGGS & STRATTON MAGNEMATIC IGNITION SYSTEM

**Magnematic Ignition—Models 9-14-23**

It is not necessary to remove blower housing of flywheel to adjust or replace breaker points or condenser.

**To Adjust Breaker Points**

The breaker points are located in the breaker box at the front of engine. Fig. 34. Remove cover by loosening two screws at opposite corners. Be sure that none of the wires attached to the breaker plate are grounded against the box or cover. Adjust breaker points as follows: Rotate crankshaft until points open to widest gap. Loosen breaker plate screw slightly. Rotate eccentric to secure .020" gap and tighten breaker point screw. Fig. 35.

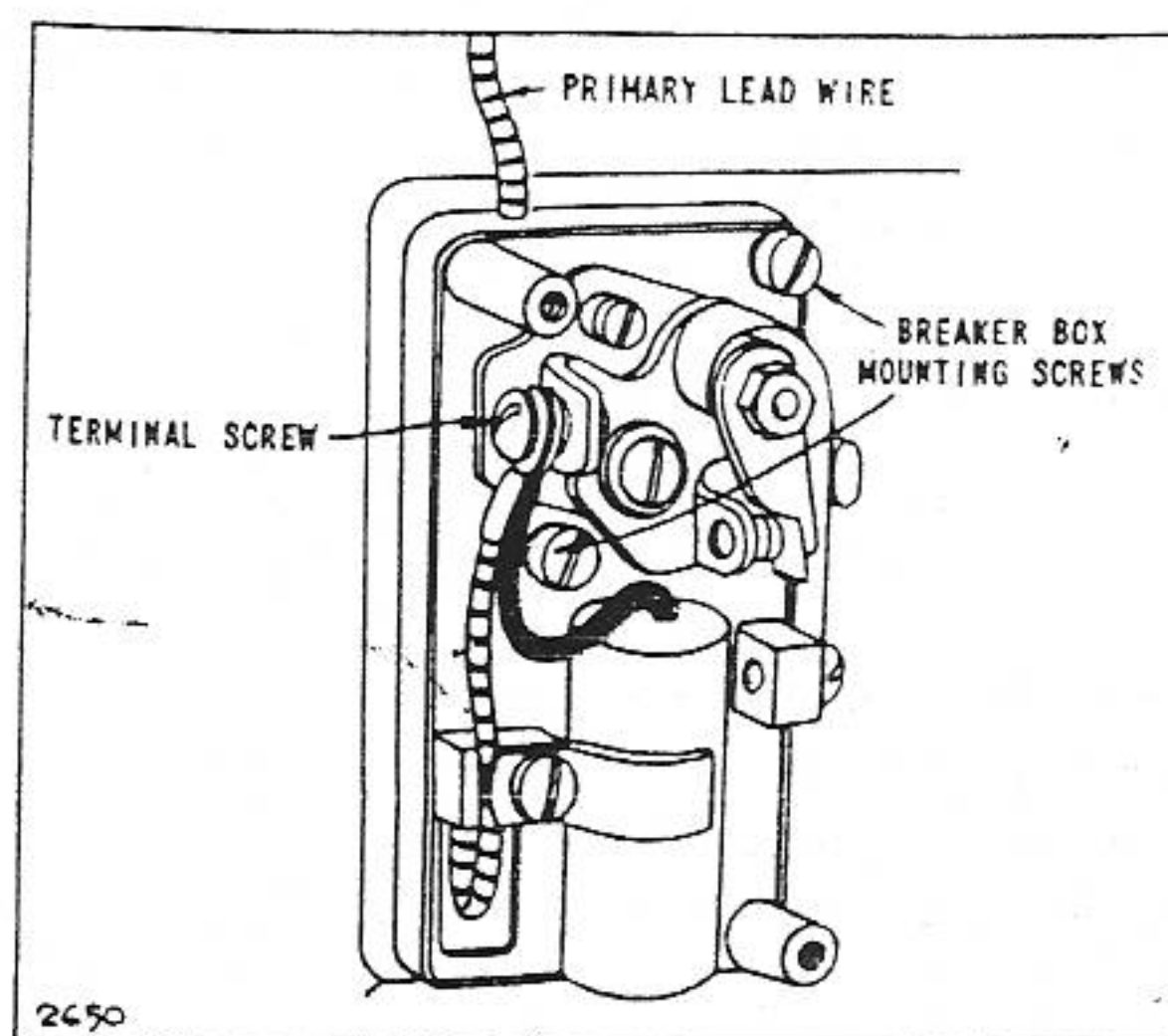


FIG. 34—BREAKER BOX

### To Replace Breaker Points

Rotate crankshaft until points are in wide open position and leave crankshaft in this position while changing points. Remove terminal screw. Fig. 36.

Remove spring screw. Loosen nut until top of nut is flush with end of threaded shaft. Tap nut with light hammer to free breaker point from taper of shaft. Remove nut and breaker point. Remove breaker plate screw and breaker plate.

Pry out the breaker shaft oil seal with a thin ice pick. Press in a new seal with the metal side out. Put new breaker plate on top of insulating plate taking care that the dowel in breaker plate engages hole in insulating plate. Fasten breaker plate screw only enough to put a light tension on the plate. Adjust eccentric so that left edge of insulating plate is parallel to edge of box and tighten screw. This locates the breaker plate so that proper gap adjustments may be made. Fig. 37 Turn breaker shaft in clockwise direction as far as possible.

Place new breaker point on shaft, then the lockwasher and tighten nut down on lockwasher. Replace spring screw and terminal screw. Adjust points by loosening breaker plate screw slightly and rotating eccentric to secure .020" gap between points. Tighten breaker plate screw.

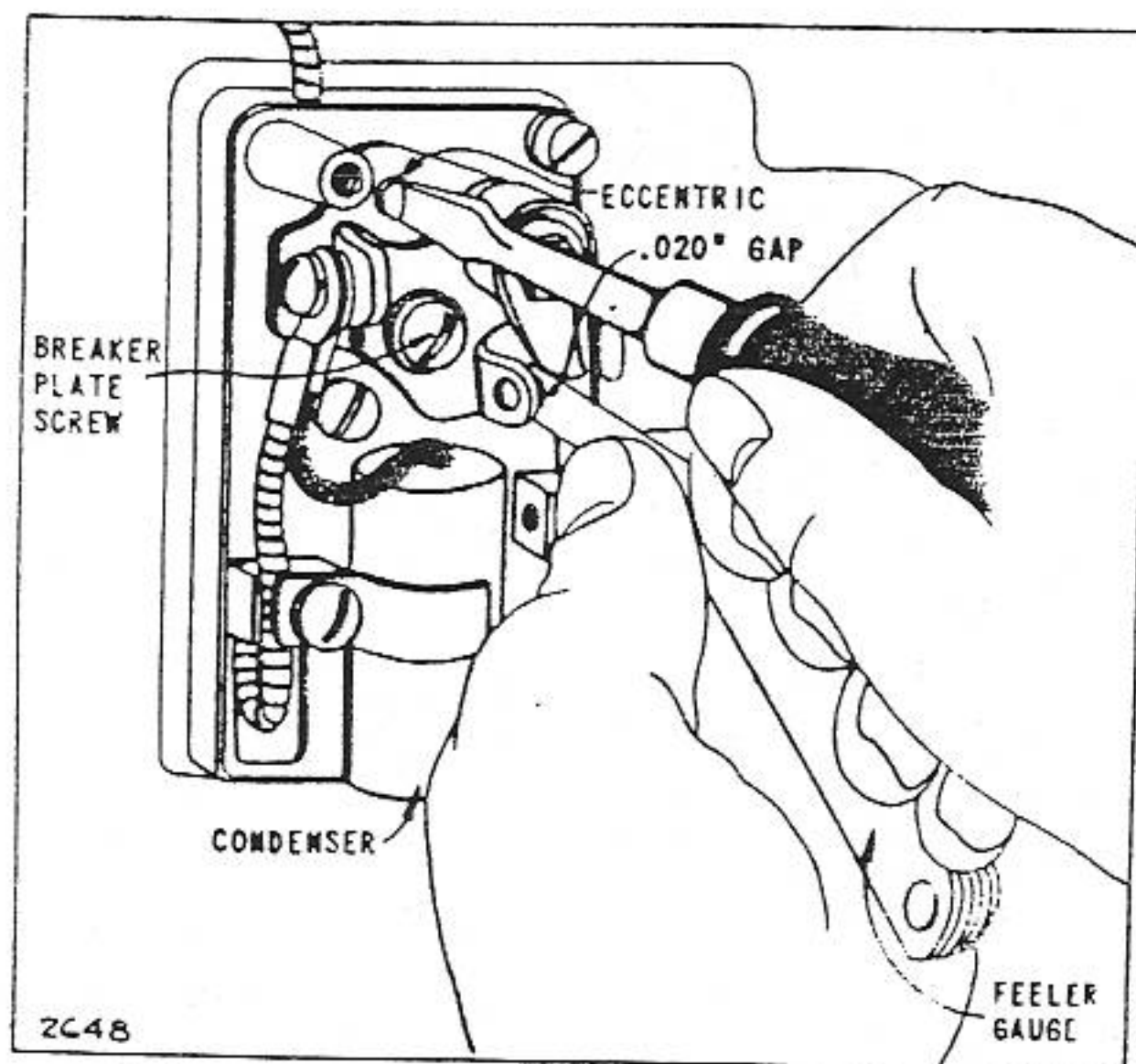


FIG. 35—ADJUSTING BREAKER POINTS

### To Replace Condenser

Fasten the condenser lead wire and primary lead wire to breaker plate as shown in Fig. 34. The condenser mounting bracket also holds the primary lead wire in place.

### To Replace Breaker Box Assembly

Remove breaker box cover. Rotate crankshaft until points open to the widest gap. Remove terminal screw. Fig. 34. Remove two breaker box mounting screws.

To reassemble, reverse above operation, but adjust points before assembling cover as explained previously.

### To Replace Breaker Shaft

Turn crankshaft until points open to .020", then remove breaker box assembly as explained above. Loosen the

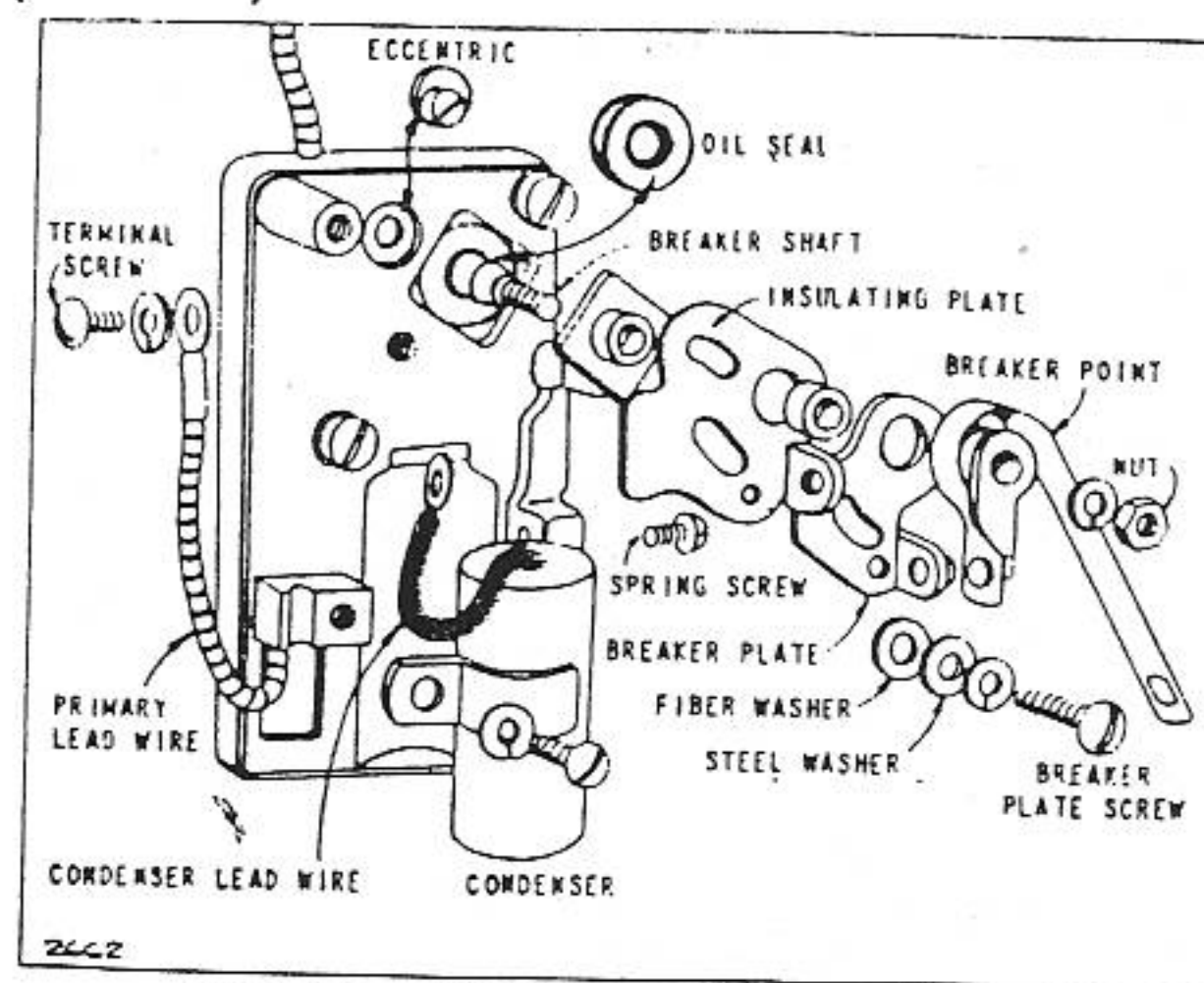


FIG. 36—BREAKER BOX ASSEMBLY

shaft nut until it is flush with end of shaft. Tap nut with a light hammer to free bearing shaft from breaker point. Remove nut and lockwasher. The shaft must be turned a half revolution in order to remove it from the breaker box.

Insert the new shaft and turn until the arm is downward. Assemble breaker box to the cylinder. Loosen the breaker plate screw and turn adjusting eccentric until the left edge of the insulating plate is parallel to the edge of the breaker box. Fig. 37. Turn breaker shaft clockwise as far as possible, then assemble lockwasher and nut. Tighten nut securely.

Rotate eccentric until breaker point gap of .020" is obtained, then tighten plate screw. Replace breaker box cover.

NOTE: If lever on end of breaker shaft has broken off and points will not open, remove breaker box, turn crankshaft until the breaker cam stop pin on cam gear lines up with the bottom of breaker box hole in cylinder. The breaker shaft should be replaced and points adjusted.

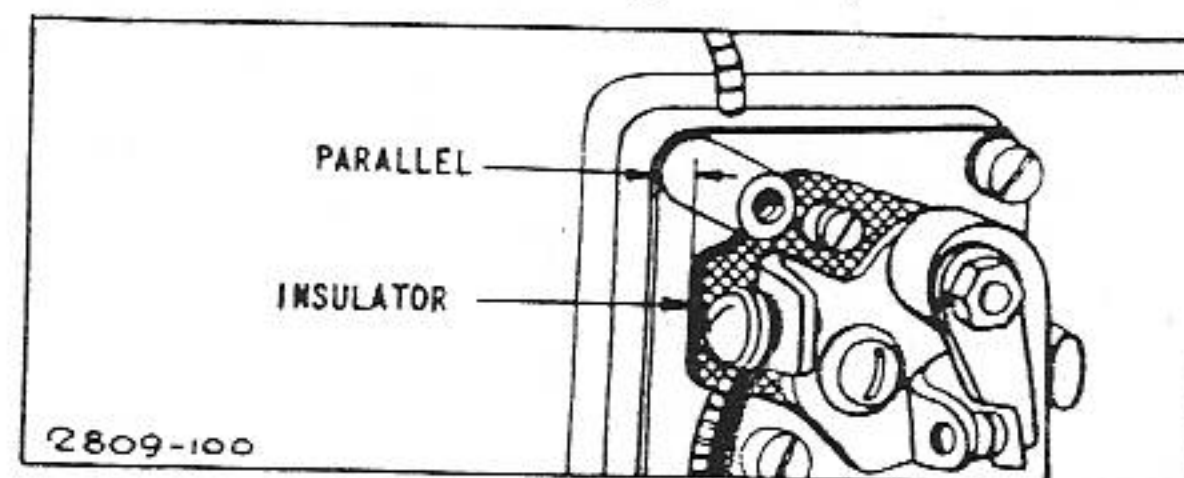


FIG. 37—INSULATING PLATE POSITION

### To Replace Rotor

Remove the locking screw and the set screw, then slide rotor from the crankshaft. If crankshaft or bearing support is to be disassembled, the rotor key should be removed and any burr on the crankshaft at the keyway, or set screw hole, should be carefully removed with a file.

CAUTION. Keep watches away from rotor to prevent their being magnetized.

To reassemble, place key in keyway, then slide rotor onto crankshaft until the set screw hole in rotor and crankshaft are aligned. Be sure that key remains in place. Tighten the set screw securely, then tighten the lock screw to prevent set screw from loosening. The lock screw is self-threading and the hole does not require tapping. Fig. 38.

(See Following Page)

**NOTE:** On some earlier Model 14 engines the set screw was locked into place with a cotter pin. It is important that the set screw be very tight. If adjustment is necessary in order to insert the cotter pin, the set screw should be tightened, not loosened.

**To Adjust Rotor Timing**

The rotor and armature are correctly timed at the factory and require timing only if the armature has been removed from the engine, or if the cam gear or crankshaft have been replaced. If necessary to adjust, proceed as follows: Set point gap at .020" and, with rotor properly located on the crankshaft by means of the pointed set screw, turn the crankshaft in normal direction of rotation until breaker points just start to open. If necessary, use a timing light or insert a piece of tissue paper between the breaker points to determine when points begin to open. Loosen the three armature mounting screws slightly and rotate armature until the arrow on armature lines up with the arrow on rotor as shown in Fig. 38. Align with corresponding number of engine model. On model 9, align with 9, etc. Retighten armature mounting screws.

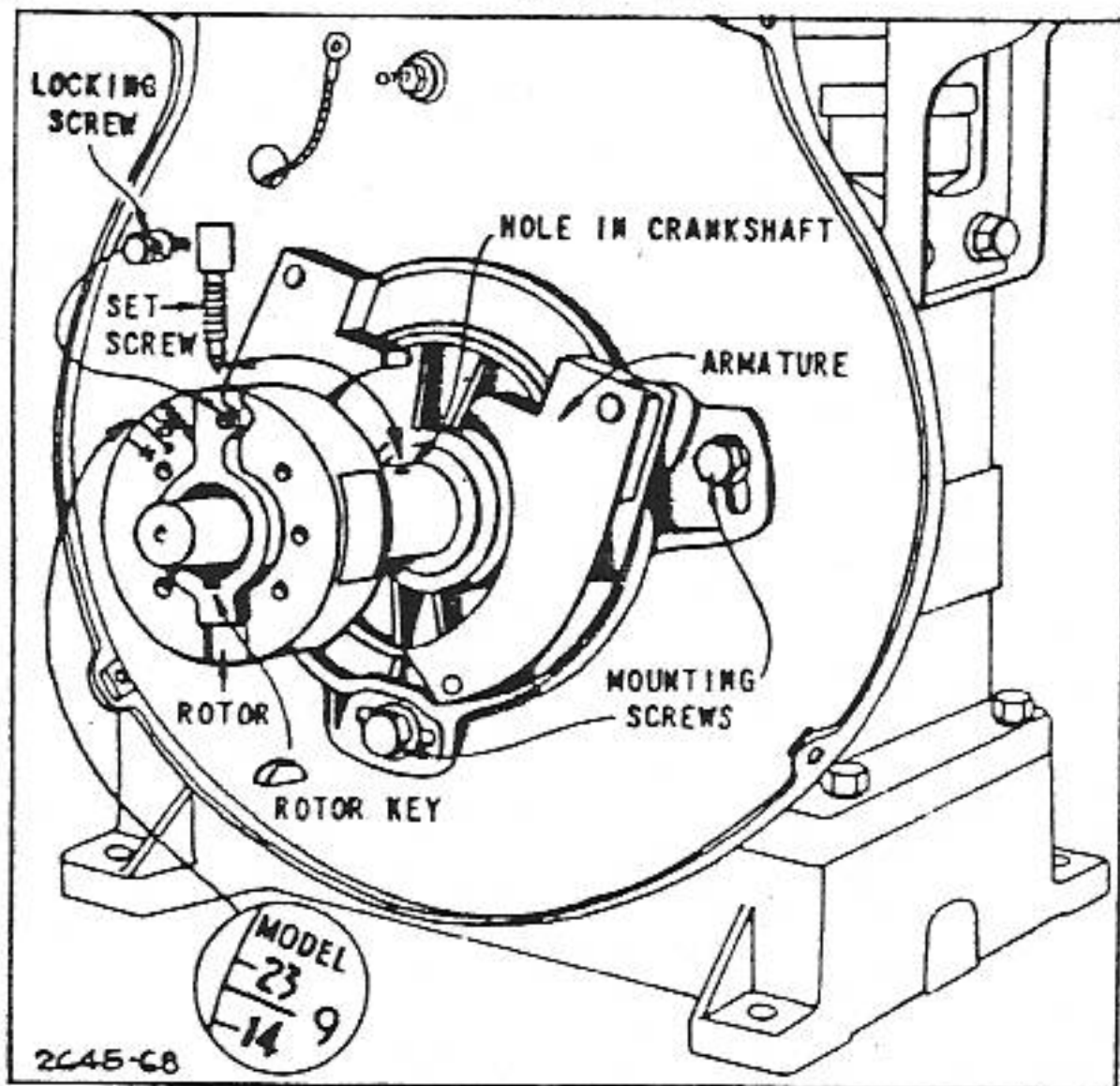


FIG. 38—REPLACING ROTOR

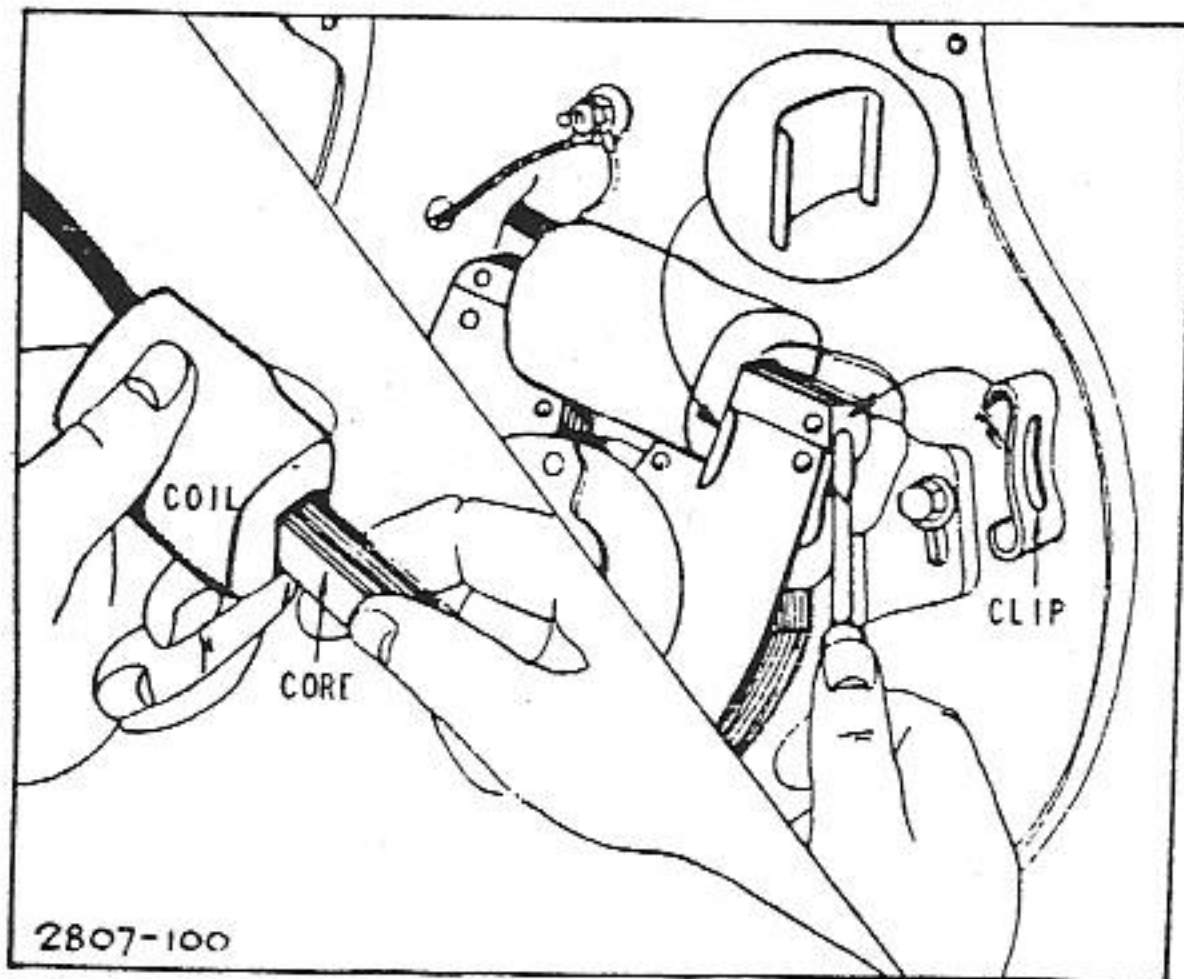


FIG. 39—REPLACING COIL

**To Replace Coil**

With flywheel removed, loosen the primary lead wire, primary and secondary ground wires from back plate. Pry out clips at each end of coil core. Hold hand over clips while removing. Pull ignition cable through back plate but be careful not to pull terminal from ignition cable. Coil can now be pushed off or onto the core, if it is to be replaced. Fig. 39.

Reassemble coil by reversing the above operation, but be sure that the primary wire from coil is assembled between ignition cable and back plate. Inspect this wire and the armored primary wire leading from terminal on back plate to the breaker box for frayed ends or broken insulation which may cause short circuiting.

The coil retainer is assembled between the coil and armature with rounded side toward the coil.

**Ignition Cable**

The cable is permanently fastened to the coil and any attempt to remove it will result in damage to the coil.

Examine cable at the spark plug end and be sure that the wire strands are not broken loose from the terminal. Insulation must not be broken or soaked with water or oil, or grounded in any way that will prevent proper ignition.

**To Replace Armature**

The armature is fastened to the crankcase with three screws which also hold the back plate in place. After armature is reassembled, the rotor timing must be adjusted as explained previously.

**To Check Automatic Spark Advance**

Place cam gear in normal operating position with the movable weight down. Press the weight down to stretch spring. Release, and the spring should then lift the weight. If not, the spring is stretched or the weight is too tight. Fig. 40.

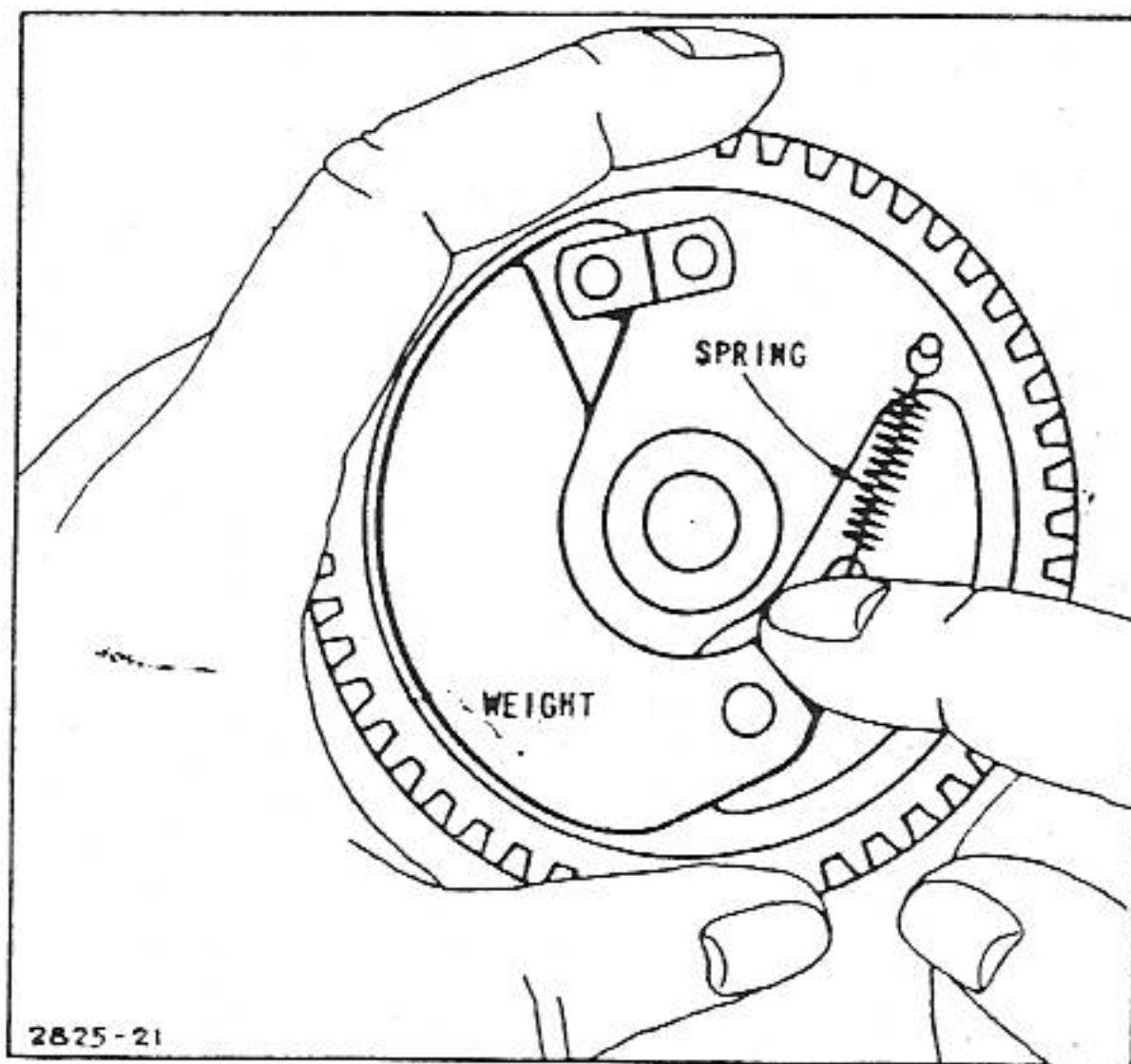


FIG. 40 — CHECKING AUTOMATIC SPARK ADVANCE

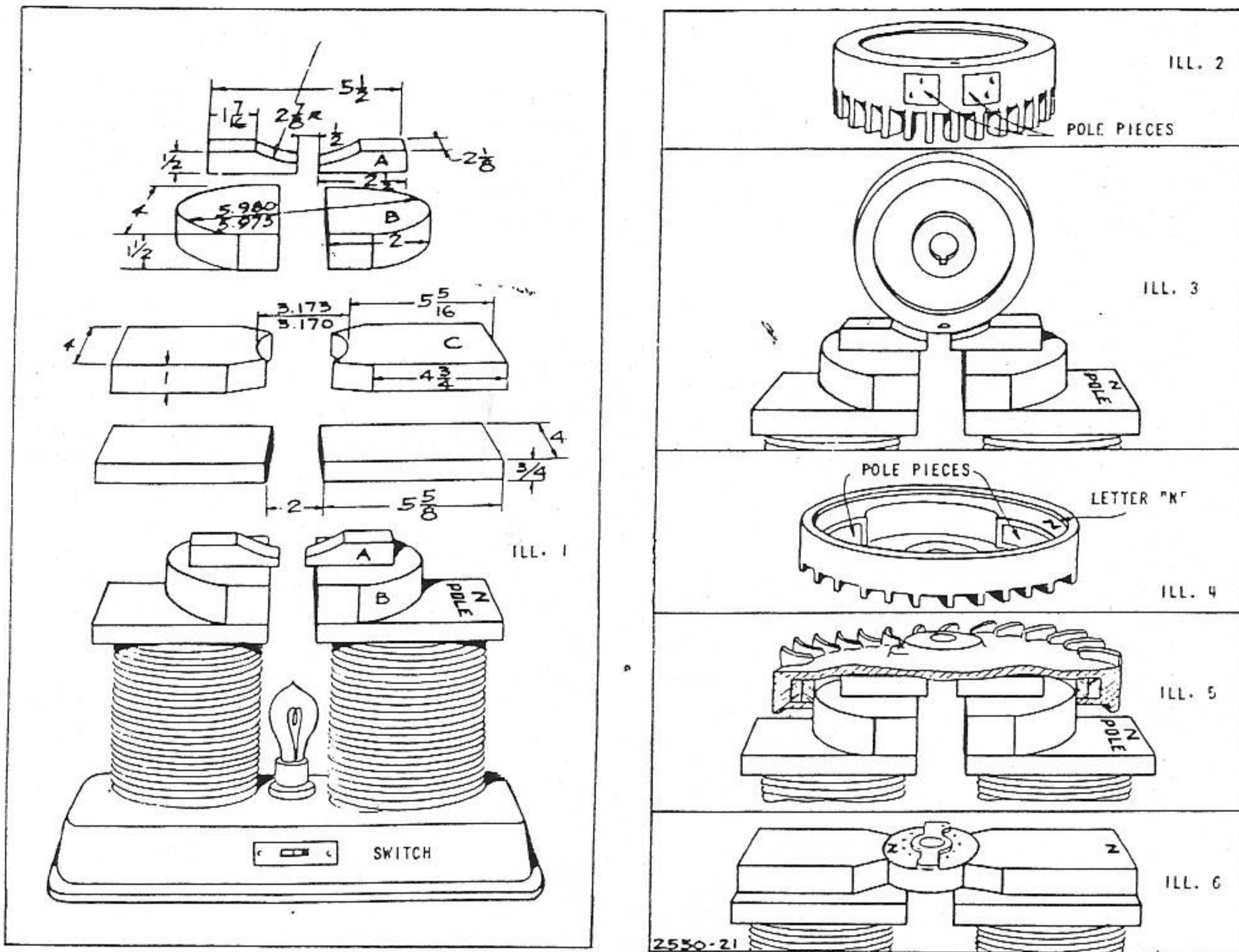


FIG. 41—MAGNETIZING FLYWHEELS &amp; ROTORS

### MAGNETIZING FLYWHEELS AND ROTORS

Three sets of pole pieces and two plates on which to mount them should be made to the dimensions shown in Ill. 1, Fig. 41. The steel used for the pole pieces should be made of a soft steel such as AISIC 1019. Dowels or screws can be used to hold pole pieces in place. A compass should be used to locate the poles on the charger.

#### To Magnetize Flywheels

##### Models 8 and All 2" Bore

Use pole pieces "A." Hold flywheel with pole pieces toward you and fins downward (Ill. 2, Fig. 41). The pole piece to the right should go on the pole of the charger that attracts the NORTH seeking end of the compass

needle (Ill. 3, Fig. 41). Apply current twice for 3 seconds each with 1 second intervals.

#### Models

##### A-B-FH-FI-FJ-M-K-L-M-PB-Q-R-S-T-W-Y-Z-ZZ

Use pole pieces "B." The pole of flywheel marked "N" should be placed on the pole of the charger which attracts the NORTH seeking end of the compass needle (Ill. 4, Fig. 41). Apply current twice for 3 seconds each with 1 second intervals (Ill. 5, Fig. 41).

#### Models 9-14-23

Use pole pieces "C." The pole of the rotor marked "N" should be placed on the pole of the charger which attracts the SOUTH seeking end of the compass needle (Ill. 6, Fig. 41). Apply current twice for 3 seconds each with 1 second interval.

# CARBURETION

## Air Cleaners

An air cleaner properly serviced protects the internal parts of the engine from dust particles in the air. If the air cleaner instructions are not carefully followed, the dirt and dust which should be collected in the cleaner will be drawn into the engine and become a part of oil film. This results in an abrasive mixture which wears the moving parts instead of protecting them. No engine can stand up under the grinding action which takes place when this occurs. The air cleaner on every engine brought in for tune-up or repair should therefore be examined to see if it is clean. If the cleaner shows unmistakable evidence of neglect or misuse, it may be well to show it to the customer before cleaning and instruct them on the proper care to assure good engine performance. Three types of air cleaners are used on Briggs & Stratton engines—(1) Oil Bath Type, (2) Felt Type and (3) Moss Type.

### To Clean Air Cleaner

#### Oil Bath Type

Remove cover and filter and pour out oil. Fig. 42. Wash the filter element thoroughly and be sure it is completely drained before it is reassembled. Clean bowl and cover and wipe dry. Replace parts. Fill cleaner up to oil level mark on bowl with oil of the same viscosity as used in the crankcase. If the decal containing oil instructions on cleaner is worn or dirty, replace with a new decal. Part No. 27443. These are available free from factory or your source of supply.

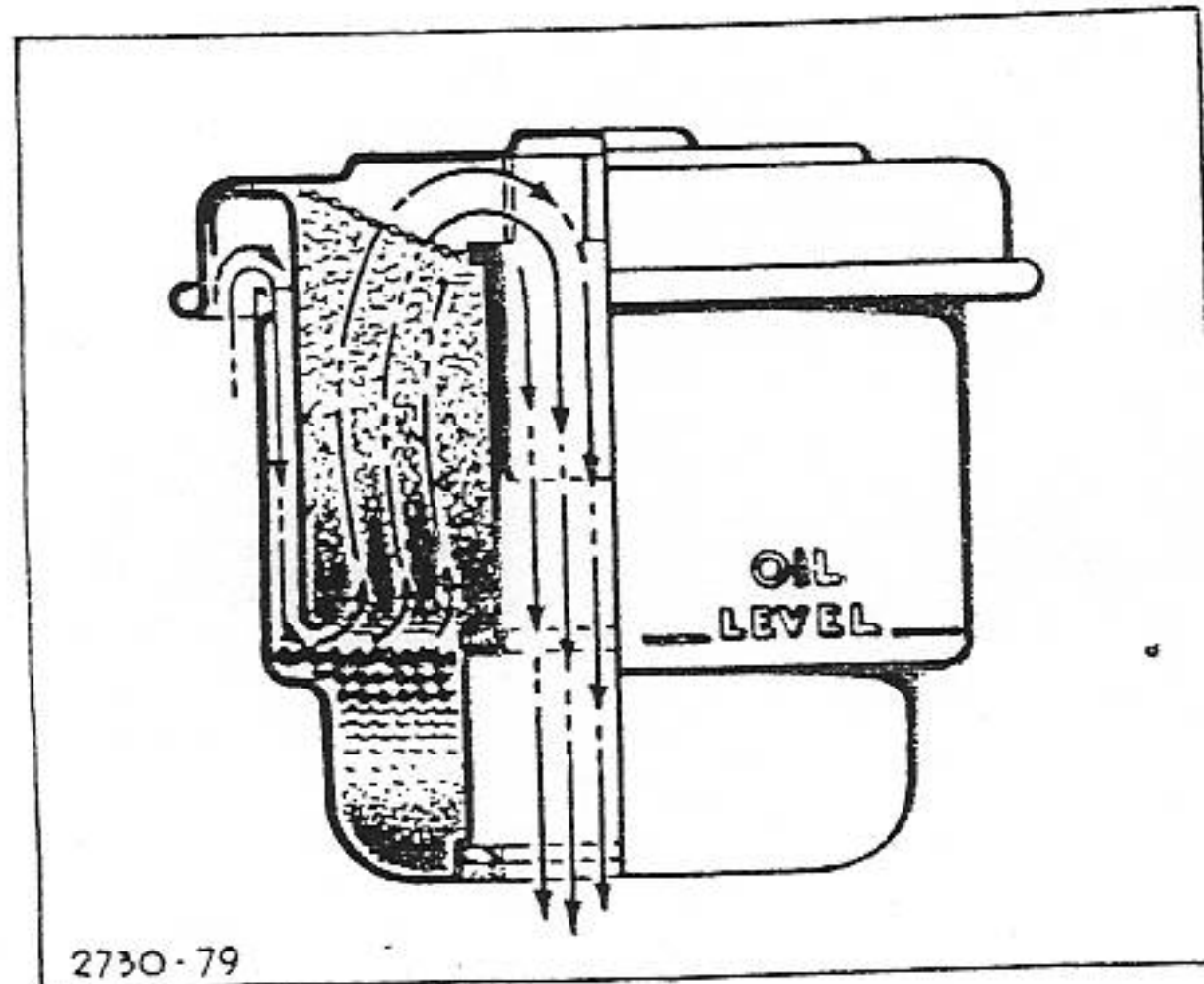


FIG. 42—OIL BATH AIR CLEANER

#### Felt Type

See Fig. 43. Rinse in gasoline. Blow all dirt out of filter element. If filter element is gummy or greasy so it cannot be cleaned, it should be replaced.

#### Moss Type

See Fig. 43. Rinse in gasoline to remove dirt. Fill with oil through holes. Let excess oil drain out. If moss is gummy and gasoline will not remove dirt and gum, air cleaner should be replaced.

## FUEL SUPPLY SYSTEM

Two fuel supply systems are used on Briggs & Stratton engines: (1) Gravity Feed and (2) Suction Feed. Fig. 44. The gravity feed system has the fuel tank above the car-

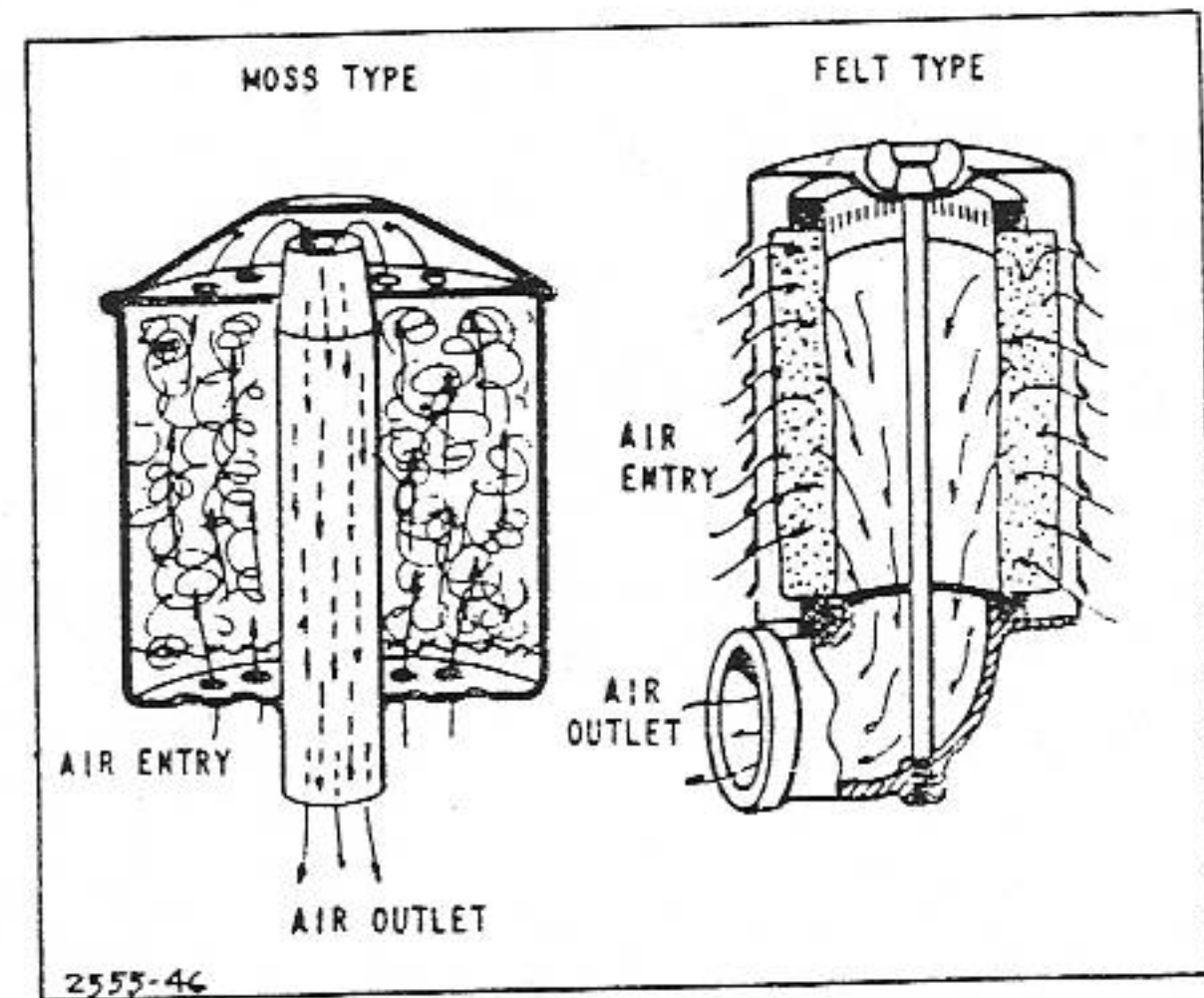


FIG. 43—FELT AND MOSS TYPE OIL CLEANER

buretor level and the flow of fuel is controlled by the float and inlet valve in the carburetor. The suction feed has the fuel tank below the carburetor and in most instances, the flow of fuel is controlled by a tank outlet (foot valve) in the fuel tank. It is important that all parts be clean and free from dirt, gum or varnish in order to operate properly. Use acetone or alcohol to remove gum or varnish.

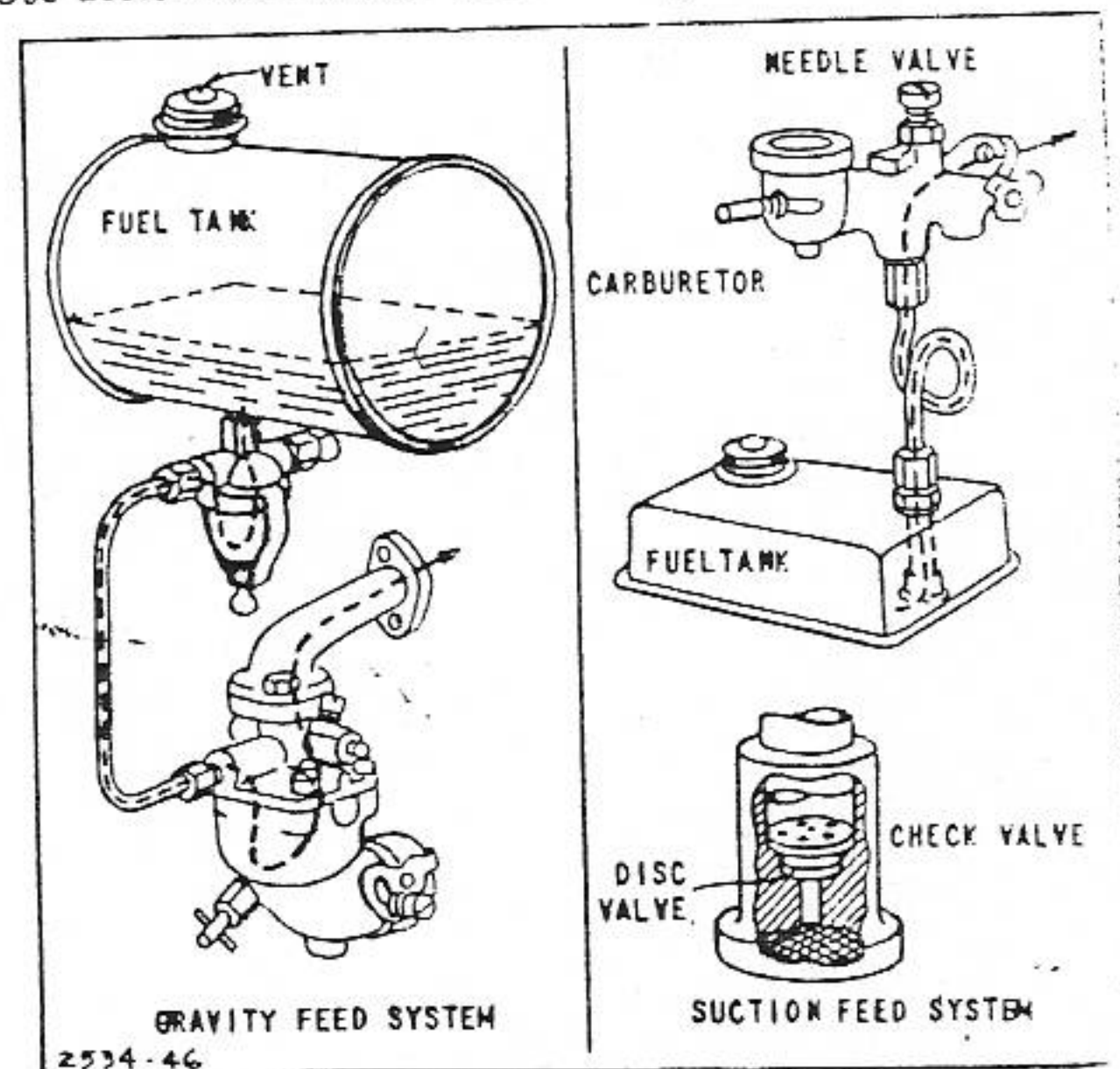


FIG. 44—CARBURETORS

**Fuel Pipe**

Remove and blow through to clean. Be sure that the connections are tight when replacing.

**Fuel Filter**

Most engine models with gravity feed type carburetors have fuel filters. To clean, first close the shut-off valve, then loosen thumb screw at bottom to remove glass bowl, gasket and screen. Open shut-off valve to see if fuel flows freely from the tank. If air bubbles appear after reassembling, loosen thumb nut until fuel overflows the filter bowl.

**Tank Outlet**

These are used on Models FH-L-NS-S-U-W1-WM-WMB-WM1-Y. Fig. 45. Remove from tank. Brush away dirt, but do not remove or damage screen. Blow through from screen end to see if check ball is free. Blow through opposite end to determine if check valve closes passage. If clogged, clean with alcohol or acetone. Be sure to replace gasket when replacing outlet in tank.

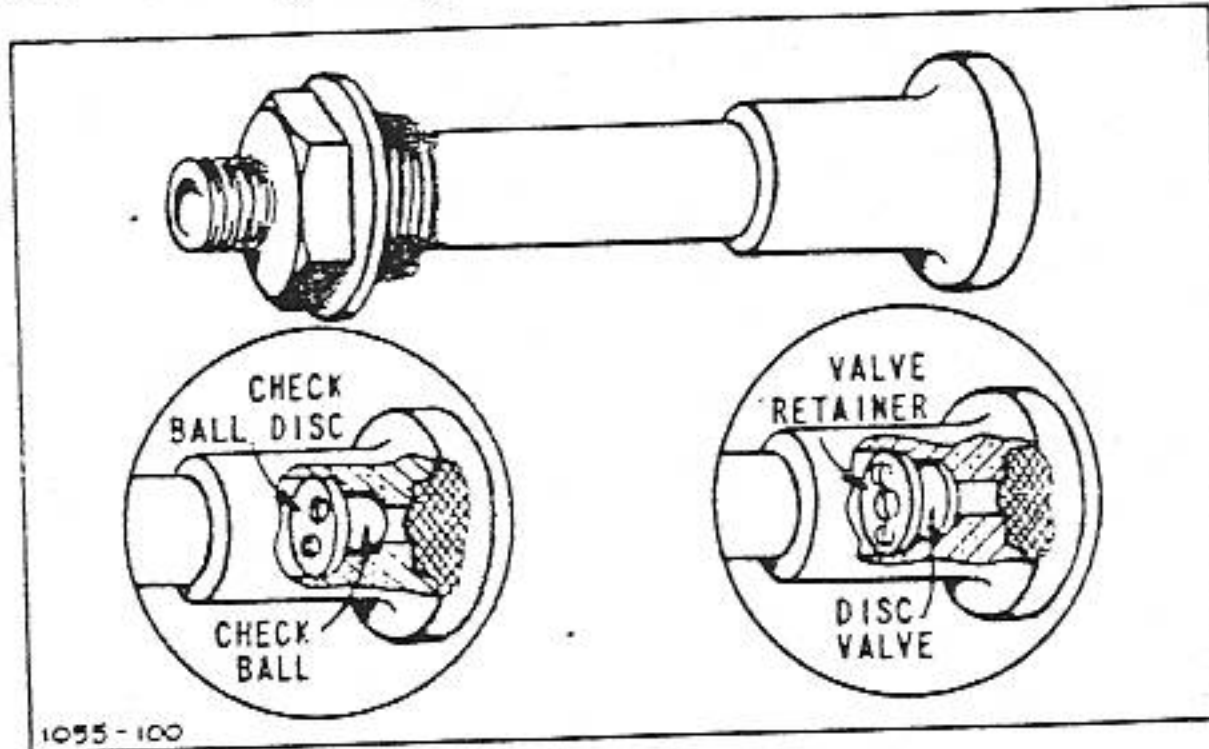


FIG. 45—FUEL TANK OUTLET

**Fuel Tank Cap**

The vent hole in the tank cap on all models must be kept open, except on Model U engines. This tank cap should be air-tight.

**Fuel Tank**

Flush tank with clean gasoline to remove dirt and water. Use alcohol or acetone to dissolve gum. The hole in the air line connection in the fuel tank on Model U must be open from .025" to .028". Fig. 94.

**GRAVITY FEED CARBURETORS**

Improper carburetion may be caused by any of the following factors: Leaking may be caused by a worn or dirty float valve, float out of adjustment, plugged air vents, or warped upper body. Excessive wear in the throttle shaft can cause engine to run erratically. A shoulder on the point of the needle valve or idle valve can prevent proper adjustment. Fig. 46.

**To Remove Carburetor**

Close shut-off valve in fuel filter or tank. Disconnect fuel line at carburetor. Remove air cleaner and elbow. Hold carburetor to prevent dropping and remove two cap screws and lockwashers from the intake elbow. Remove throttle link and governor spring. The carburetor is then free from all connections.

To reassemble, reverse the operations as performed above.

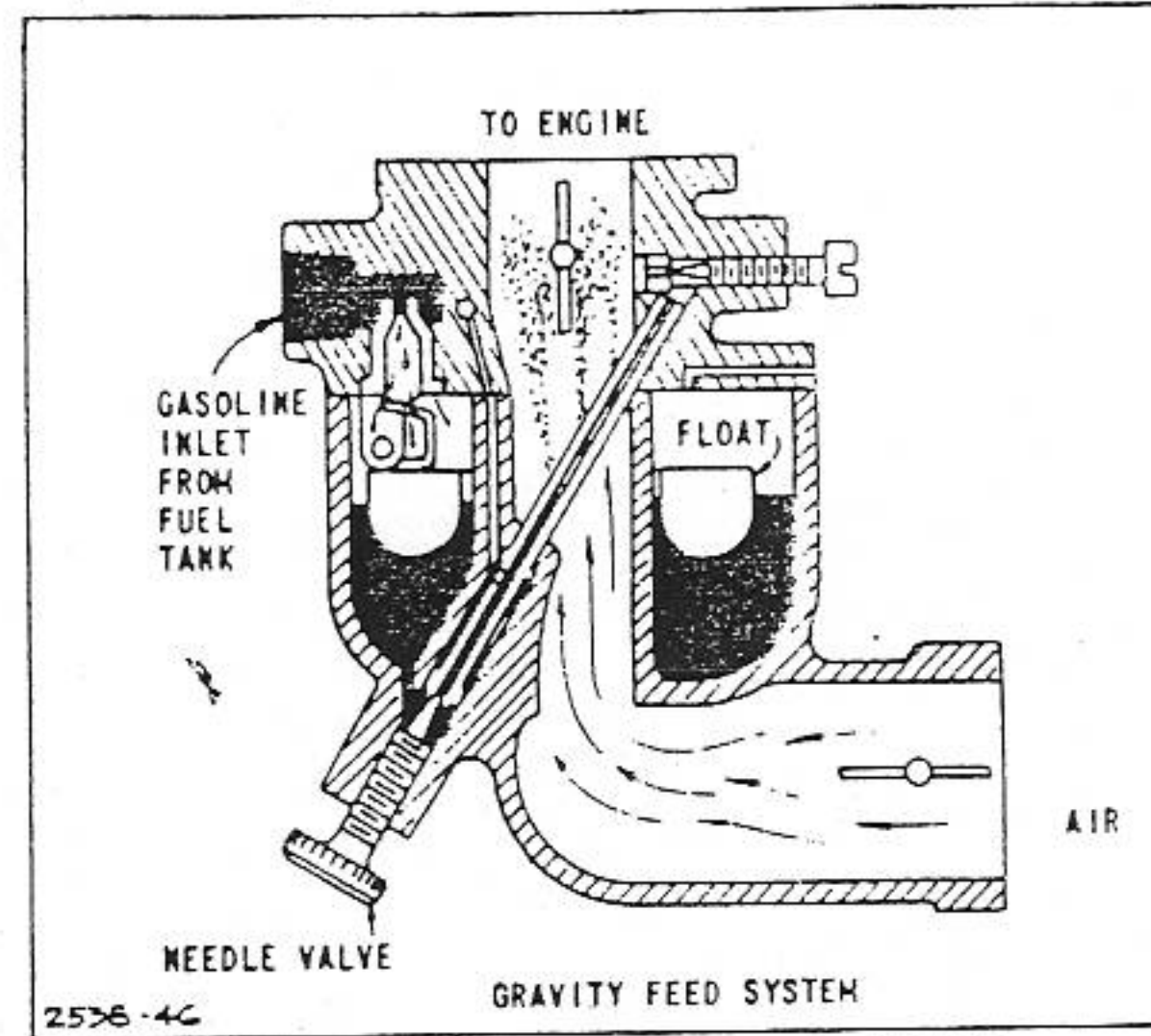


FIG. 46—GRAVITY FEED SYSTEM

**To Check Upper Carburetor Body for Warpage**

If a .002" feeler gauge can be inserted between upper and lower bodies at the air vent boss just below the idle valve, the upper body is warped and should be replaced. Fig. 47.

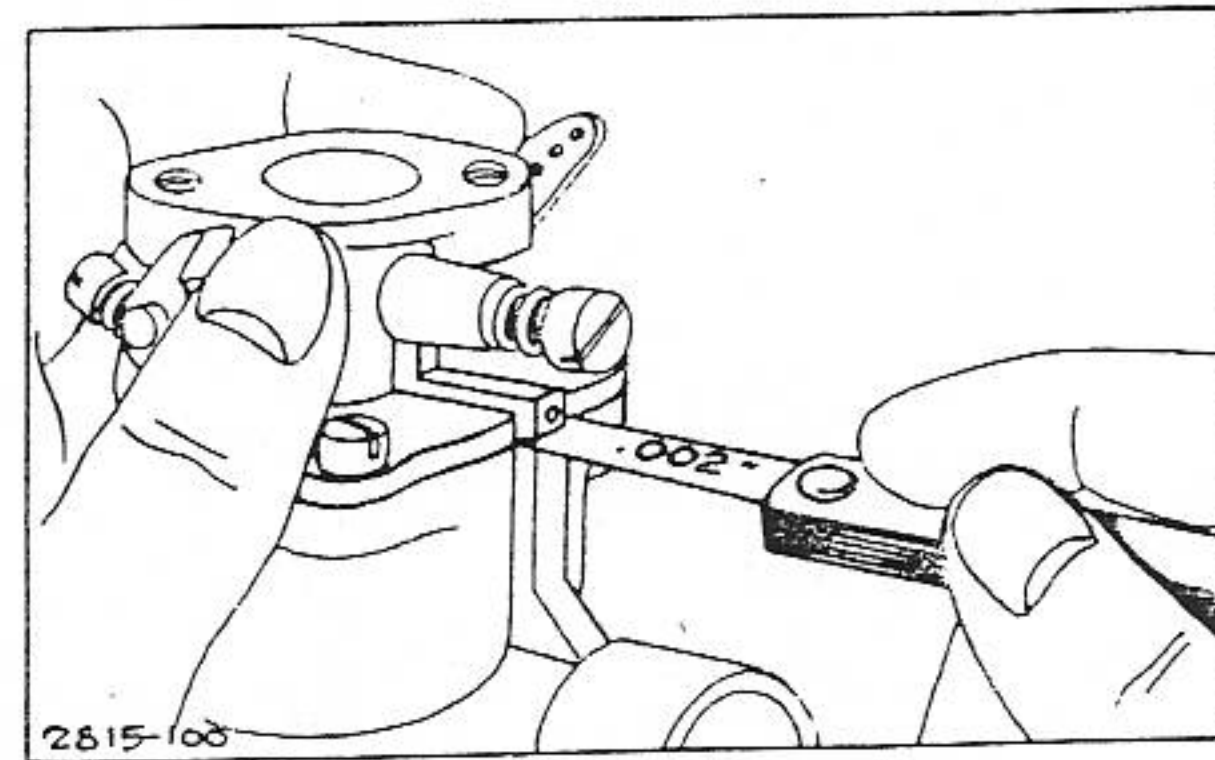


FIG. 47—CHECKING CARBURETOR BODY

**To Check Throttle Shaft and Bushing for Wear**

Place a short piece of iron bar on the upper carburetor body just below the throttle shaft as shown in Fig. 48. Hold throttle shaft down firmly and measure the distance between shaft and iron bar with a feeler gauge. Pull shaft upwards and again measure the distance between the shaft and bar. If the difference exceeds .010", it means that either the upper body should be rebushed or the throttle shaft should be replaced, or both. After throttle shaft has been removed, it can easily be determined if the wear is on the throttle shaft by comparing the worn and unworn portions of the shaft.

**To Disassemble Carburetor**

Use a 1/2" wrench and loosen needle packing nut. Screw out the packing nut and needle valve together. Use a thin, blunt screw driver to remove nozzle. The nozzle projects into a recess in the upper body. It must be removed before body is separated from lower body. Fig. 49. Remove the four screws holding upper and lower body. Take out idle valve.

(See Following Page)

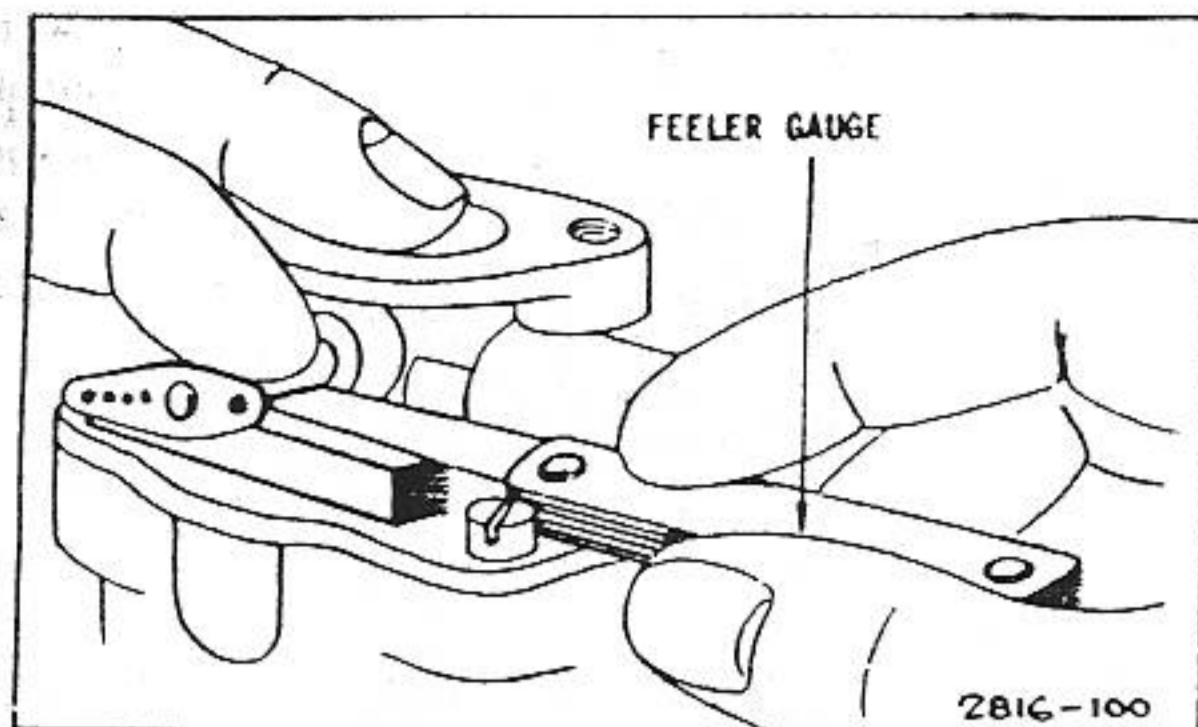


FIG. 48—CHECKING FOR THROTTLE WEAR

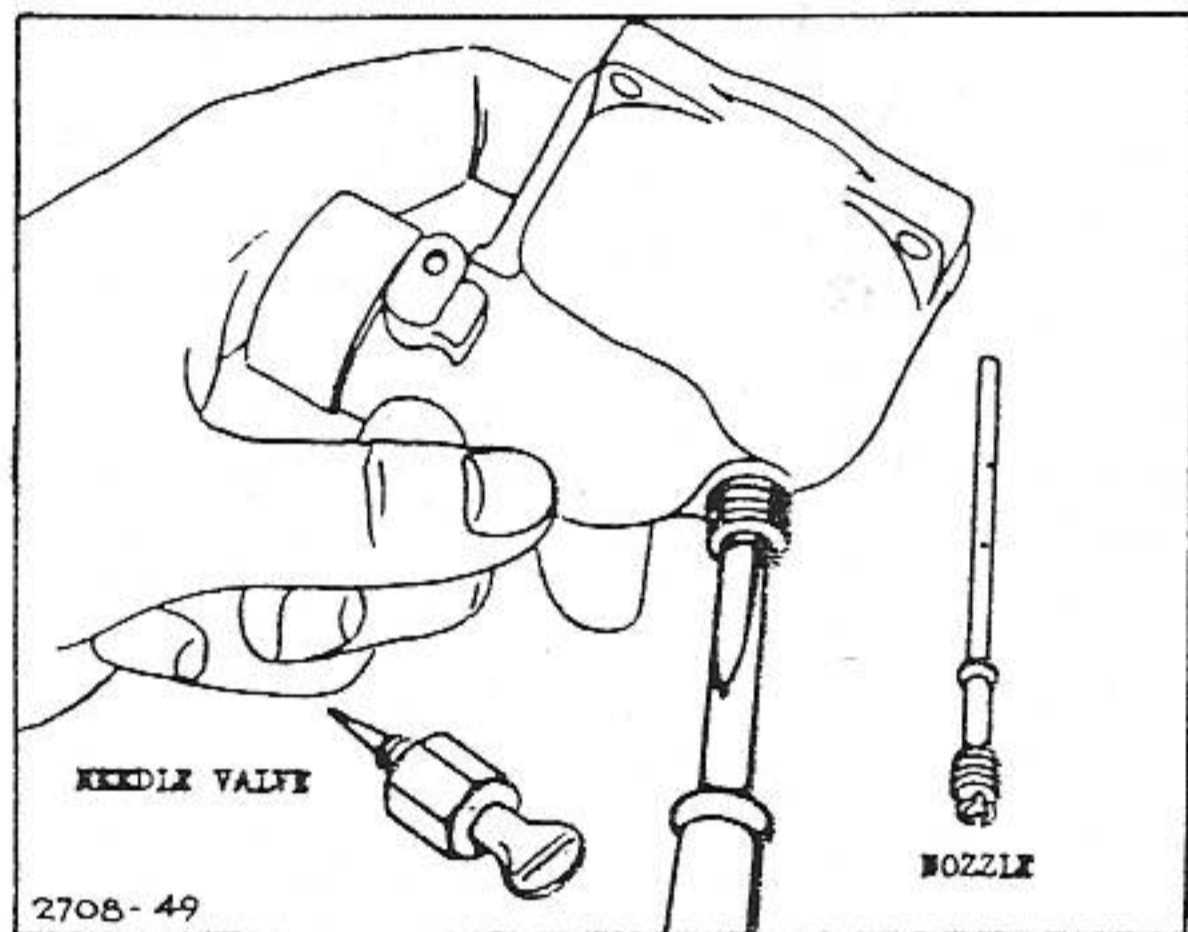


FIG. 49—REMOVING CARBURETOR NOZZLE

A pin holds the float in place. Remove to take out float and inlet needle. Check the float for leakage. If it contains gasoline, it should be discarded. A wide heavy screw driver should be used to remove the inlet seat. Fig. 50. Pull venturi out of lower body.

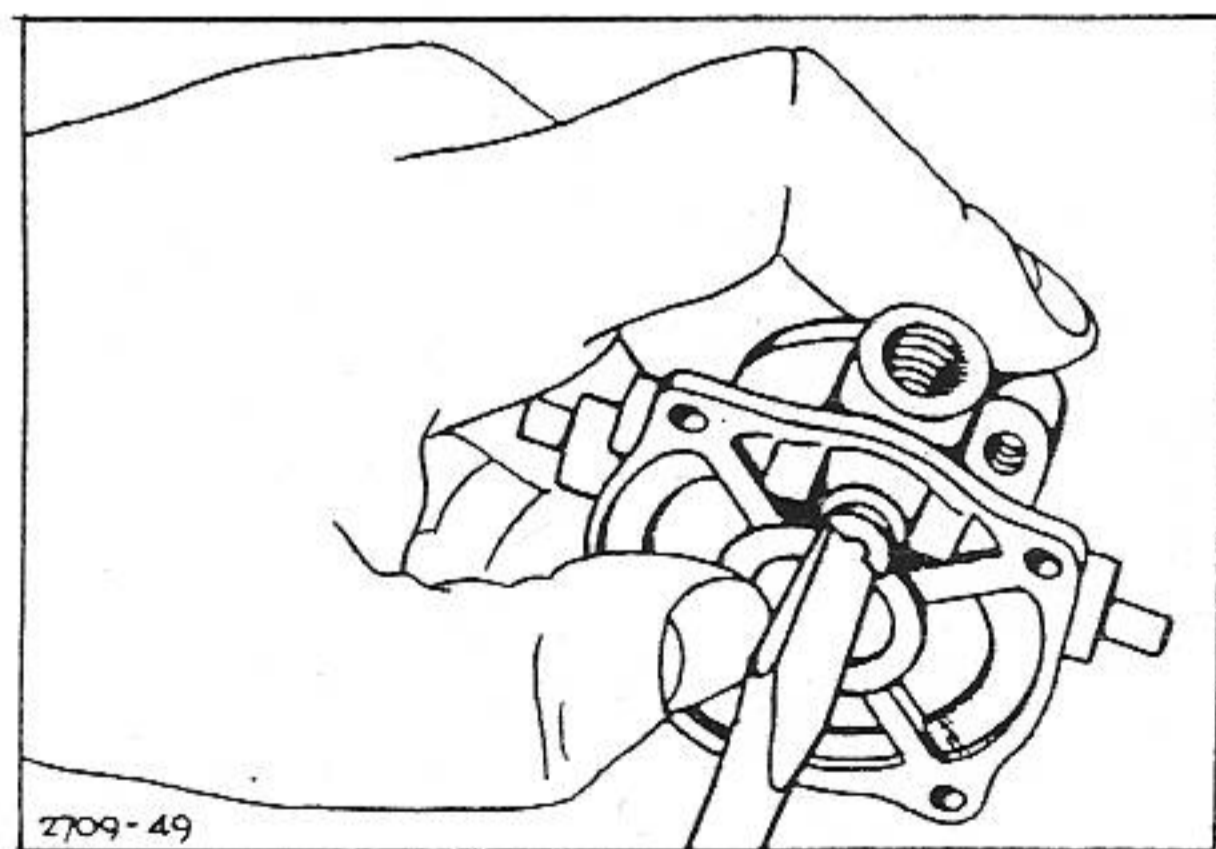


FIG. 50—REMOVING INLET VALVE SEAT

Remove throttle valve. Use a thin punch to drive out the pin which holds the throttle stop to shaft, then pull out shaft. Fig. 51. If shaft and bushings are worn, they should be replaced. Older model carburetors have no bushings and throttle body must be replaced if holes are worn. Soak and clean all parts thoroughly.

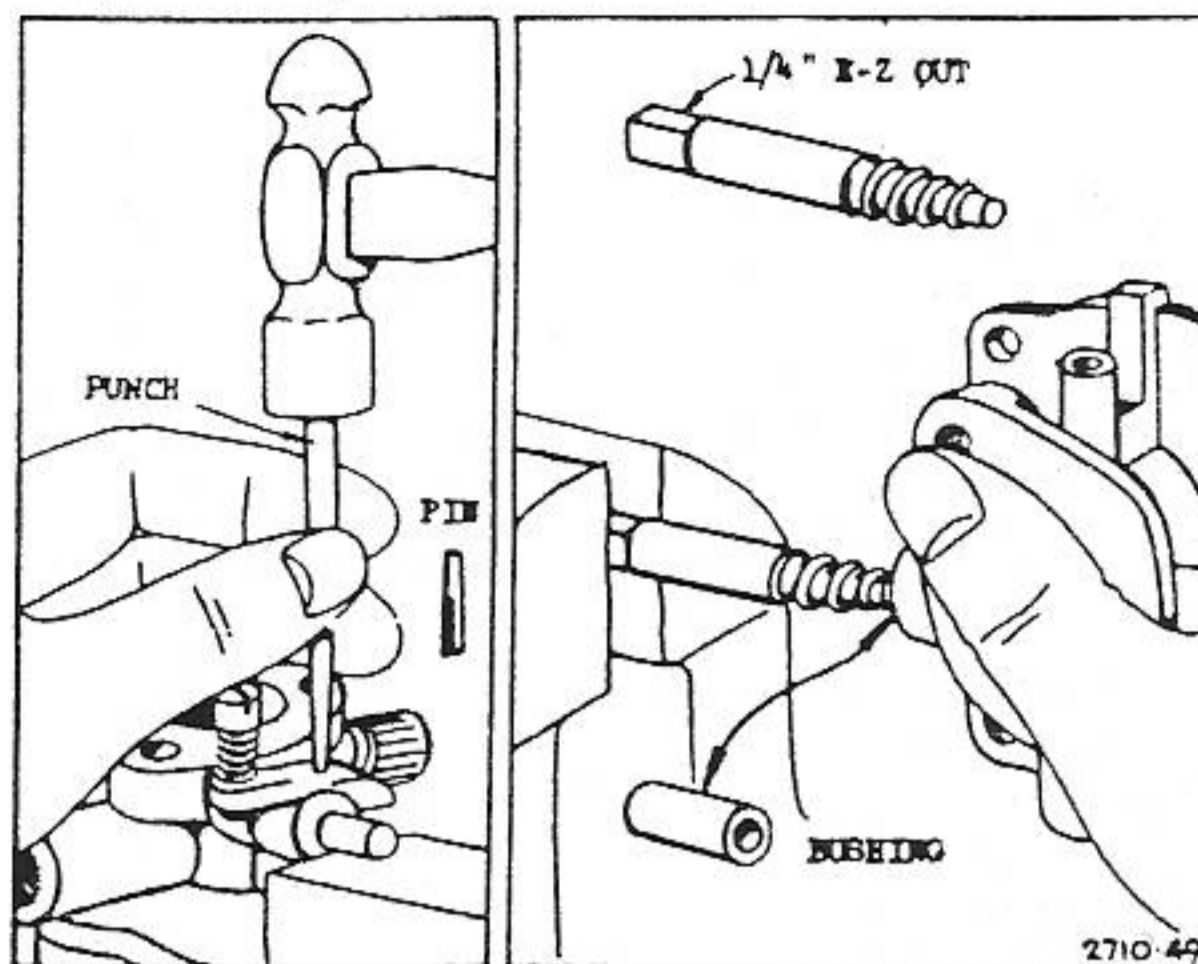


FIG. 51—REMOVING THROTTLE STOP AND BUSHINGS

**To Replace Throttle Shaft Bushings**

Place a 1/4" x 20 tap or an E-Z out in a vise. Then turn carburetor body so as to thread tap or E-Z out into bushings enough to pull bushings out. See Fig. 51. Press new bushings into carburetor body with a vise. Insert throttle shaft to be sure it is free in the bushings. If not, run a size 7/32" drill through both bushings to act as a line reamer.

**To Reassemble Carburetor**

Use new gaskets and new parts where necessary. Carburetor repair kits are available. Screw inlet seat with gasket securely into place. Drop inlet needle into seat, place body gasket on upper body, then assemble float. Invert upper body to check the float level. The float should be parallel to the body mounting surface. If not, bend tang on float until they are parallel. See Fig. 52. Assemble venturi and gasket to lower body. Be sure the holes in gasket and body are aligned. All models do not have a removable venturi.

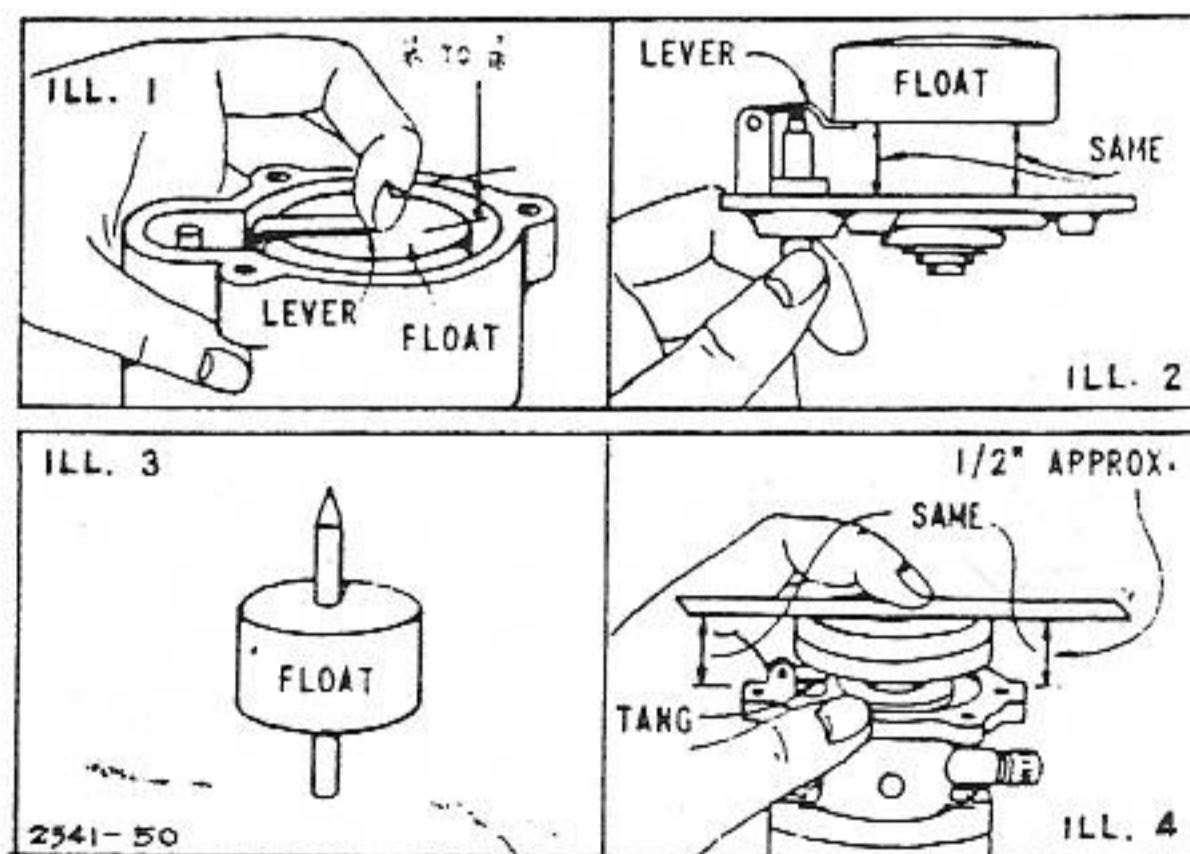


FIG. 52—CHECKING FLOAT POSITION

Fasten upper and lower bodies together with four mounting screws. Screw in nozzle with narrow, blunt screw driver, being careful that the nozzle tip enters the recess in the upper body. Tighten nozzle securely. Screw in needle valve until it just touches the seat, then turn it back about 1 1/2 turns. Do not tighten packing nut.

(See Following Page)

Screw in idle valve until it just touches the seat, then turn it back about  $\frac{3}{4}$  of a turn.

The above needle and idle valve setting are approximately correct. Final adjustment should be made when the engine is running.

### To Adjust Carburetor

Turn needle valve in until engine misses, then turn needle valve out past smooth operating point until engine runs unevenly. Then turn needle valve in just far enough so that engine runs smoothly. Tighten packing nut.

Set idle adjusting screw until engine idles at the proper idle speed, Table No. 5, Page 13. Hold throttle in idle position. Turn idle valve in or out until engine picks up speed and runs smoothly. Then again reset idle adjusting screw to bring engine to proper idle speed. Release throttle. Engine should accelerate without hesitation or sputtering. If it does not accelerate properly, the needle valve should be readjusted, usually to a richer mixture. See Fig. 46.

## SUCTION FEED CARBURETORS

The suction feed carburetors are of much simpler design than the gravity feed type. In some instances there are no repairs other than replacing needle valves, connectors, etc. Fig. 53.

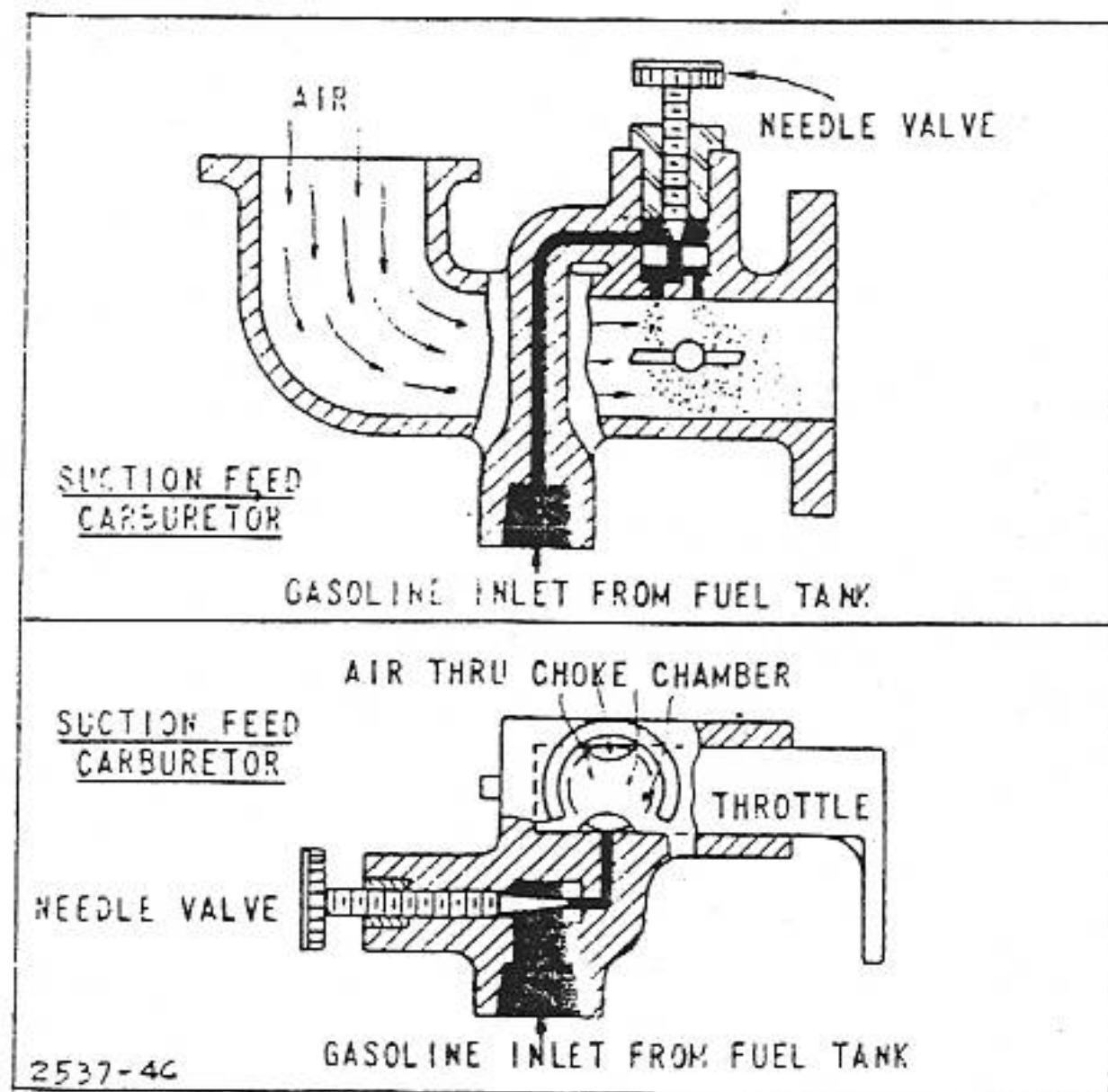


FIG. 53—SUCTION FEED CARBURETORS

### To Replace Carburetor

Remove air cleaner and fuel pipe. Loosen the carburetor mounting screws. Hold the carburetor to keep it from dropping. Unhook throttle spring and governor link. Reassemble carburetor to engine by reversing above operations. The governor linkage must operate freely.

### To Disassemble and Assemble Carburetors on Models WI-WM-WMB-WMI

The throttle shaft is held in place with a cotter pin at the end on the later models and by a throttle valve set screw on older models. Fig. 54. Remove cotter pin or set screw

and throttle shaft can be pulled out. Replace all worn parts. Replace choke valve and insert throttle as far as possible. Insert cotter pin. On older models use a pointed tool to line up locating hole for set screw. Be sure throttle stop is between forked points of throttle lever. Insert throttle and choke valve set screw. Some models have a smaller locating hole and set screw No. 63854 has a smaller tip. For other models with a larger locating hole, use screw No. 90211.

Completely close needle valve by turning to right or clockwise as far as possible. Do not screw up too far or use force when closing needle valve. The seat or taper of needle valve may be damaged. From closed position, open needle valve from  $\frac{1}{2}$  to  $\frac{3}{4}$  turns. Final adjustment is made while engine is running. See following instructions.

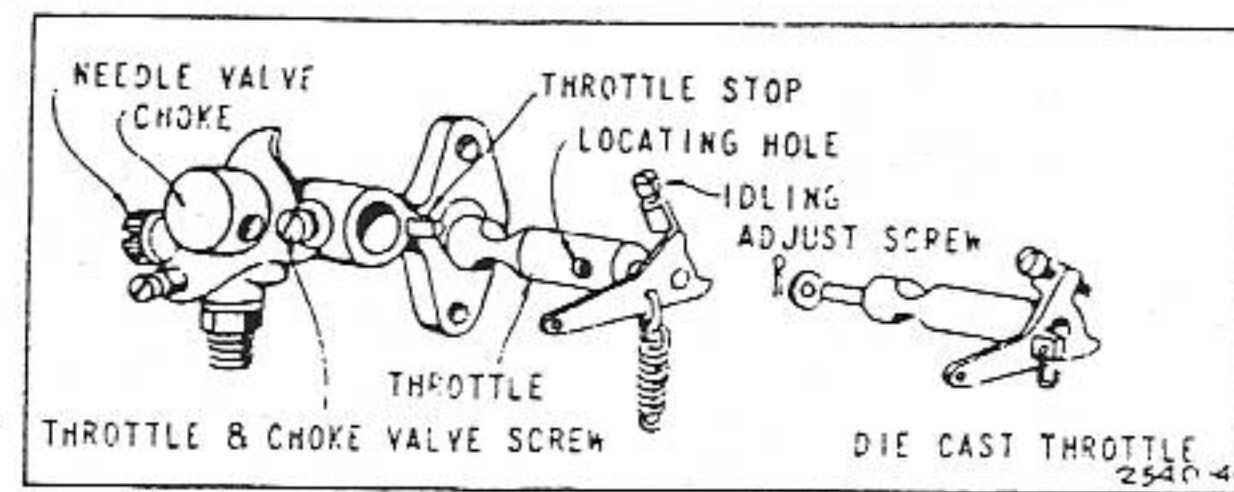


FIG. 54—MODELS WI-WM-WMB-WMI

### Models 55-6S-6HS

The fuel tank is supported by the carburetor, held in place with two screws. Fig. 55.

The carburetor throttle can be removed by loosening the idle speed adjusting screw. This permits the throttle to be turned far enough to clear the retaining lug on the carburetor body. Fig. 55.

When reassembling the carburetor be sure to replace the gasket between the fuel tank and carburetor. Screw needle valve in until it just touches the seat, then turn it back  $1\frac{1}{2}$  turns. Final adjustments should be made when the engine is running.

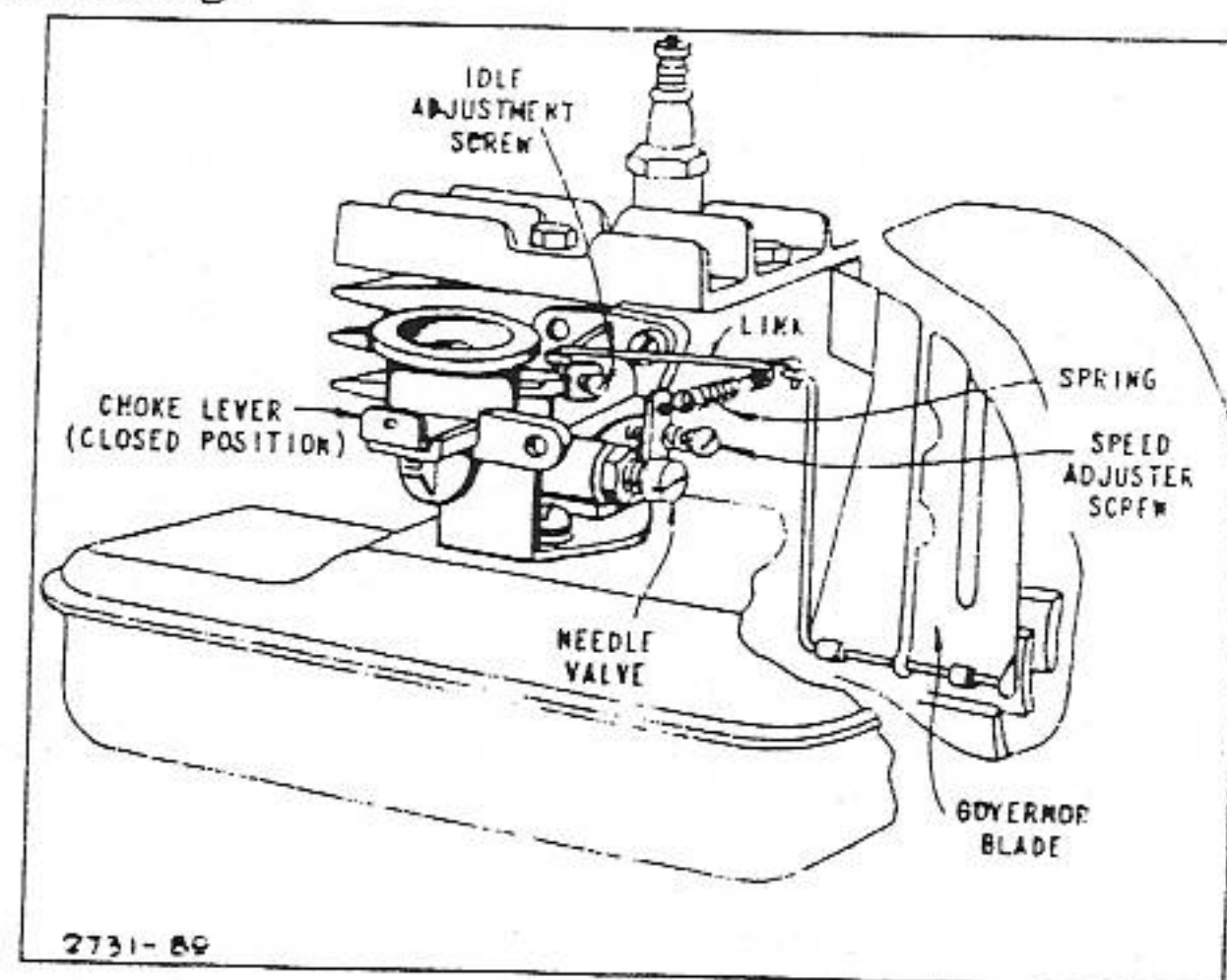


FIG. 55—MODEL 55-6S-6HS

### To Adjust Suction Feed Carburetors

The carburetor should be adjusted with the fuel tank approximately *half full*. With the engine running at normal operating speed (approximately 2700 R.P.M., no load), turn the needle valve in until engine starts to lose speed.

which indicates a lean mixture. Then open needle valve (turn counter-clockwise), very slowly until engine begins to run unevenly. This mixture should be rich enough for good performance under full load.

Then test the engine under full load. If it does not carry the load satisfactorily, it usually indicates that the mixture is still too lean and it may be necessary to open the needle valve more in order to further enrich the mixture. This richer mixture will cause a slight unevenness in idling. Place throttle in idling position. Engine should idle no slower than 1750 R.P.M. If engine idles slower than 1750 R.P.M., turn idle speed adjusting screw until this speed is reached.

**To Adjust Automatic Choke**

Loosen set screw on lever of Thermostat Assembly. Slide lever to right or left on shaft to insure free movement of choke link in any position. Rotate thermostat shaft clockwise until stop screw strikes tube. Fig. 56. Hold in this position and set lever on the thermostat shaft so that choke valve will be held open about 1/8" from closed position. Use a 1/8" rod or drill to measure space between the air horn and edge of choke valve. Then tighten set screw in lever.

Rotate thermostat shaft counter-clockwise until stop screw strikes the opposite side of tube. Fig. 57. Then open choke valve manually until it stops against the top of the choke link opening. The choke valve should now be open approximately 1/8" as before.

Check position of counterweight lever. With the choke valve in wide open position (horizontal), the counterweight lever should also be in a horizontal position with free end toward the right.

Operate the choke manually to be sure that all parts are free to move without binding or rubbing at any position.

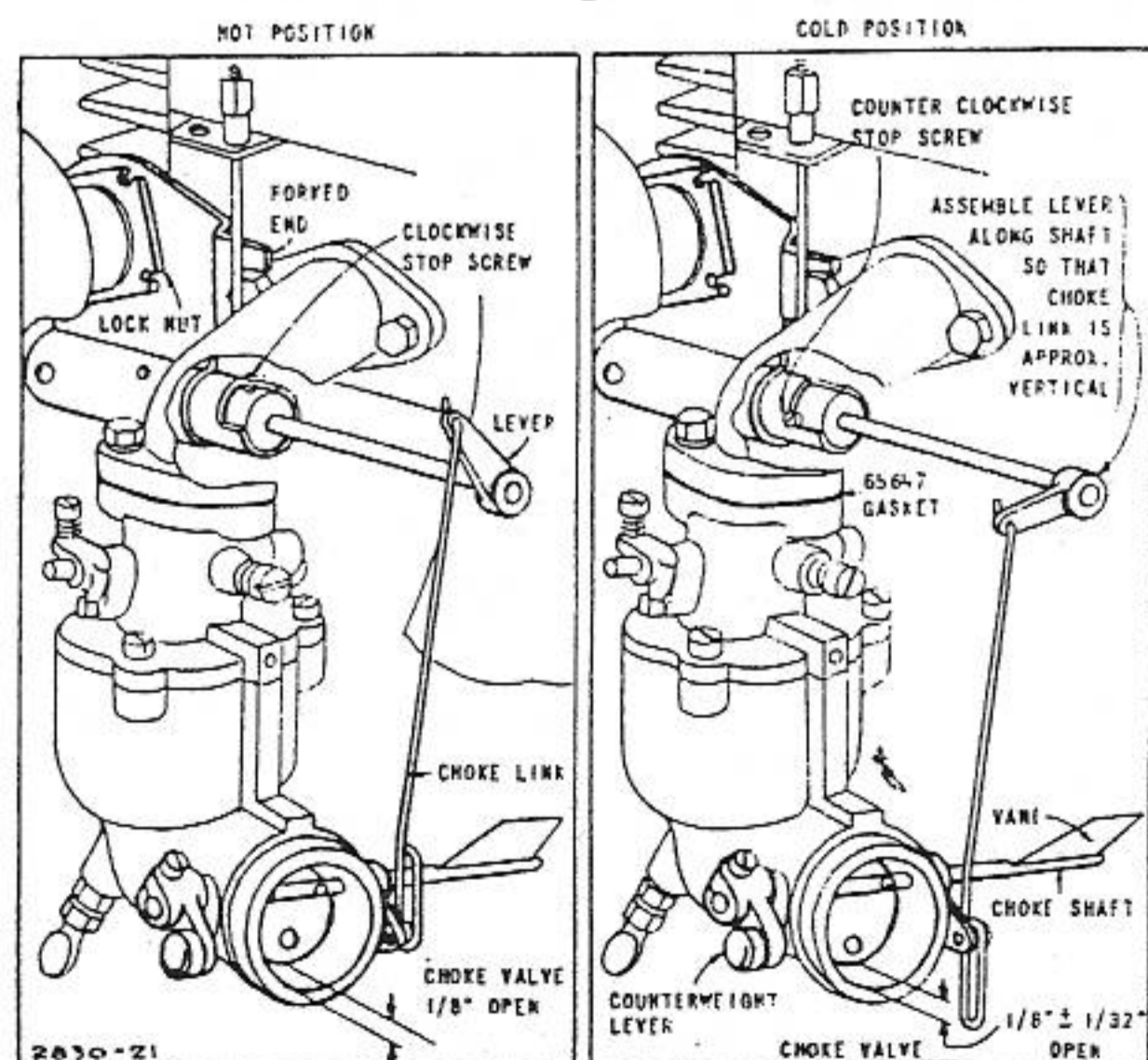


FIG. 56  
FIG. 57  
AUTOMATIC CHOKE

**To Assemble Fuel Pump**

Place a liberal supply of grease or gear lubricant on the portion of fuel pump lever that contacts the crankshaft. Fig. 58. Assemble fuel pump to cylinder using new

gasket. Keep mounting face of fuel pump parallel to mounting face of cylinder while inserting lever of fuel pump. The lever must ride in the narrow groove which is located on the crankshaft between the gear and the counterweight. Revolve crankshaft to be sure that fuel pump is correctly installed.

Assemble fuel pipe from outlet of fuel pump to inlet of carburetor. Fuel supply pipe should be connected to the inlet of the fuel pump.

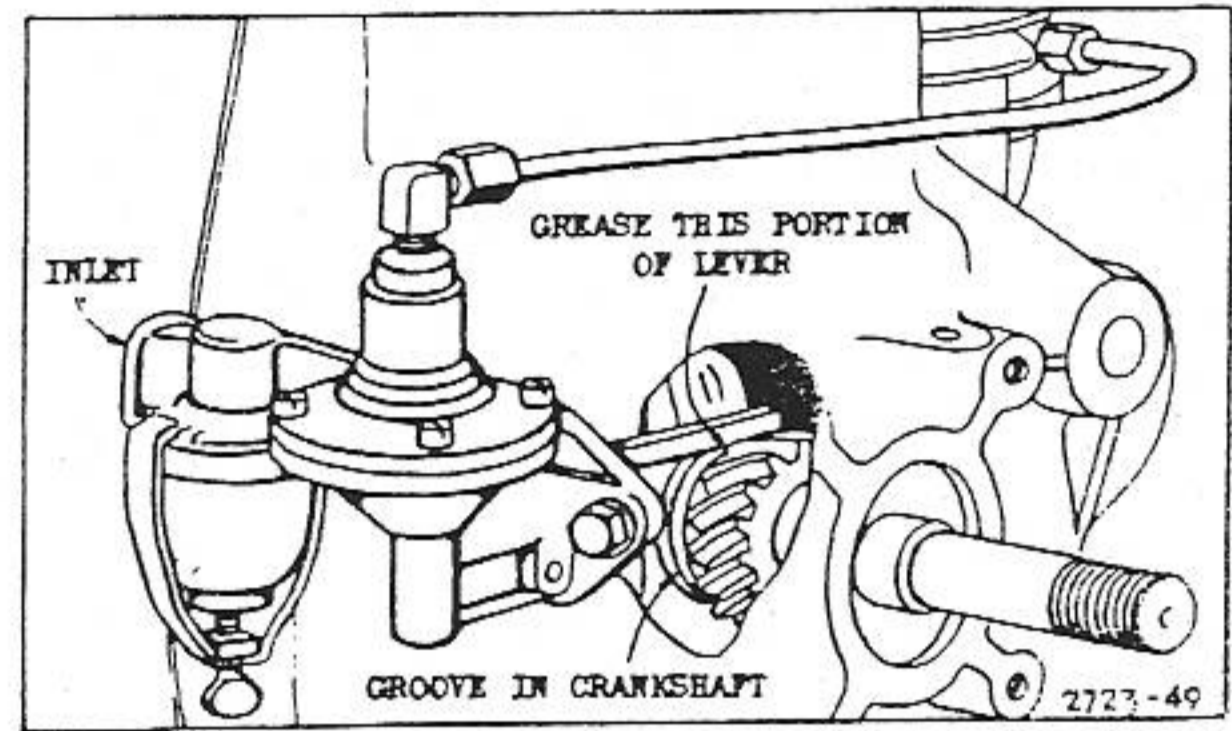


FIG. 58—FUEL PUMP

**To Replace Fuel Pump Diaphragm**

Remove pump from cylinder and then remove four screws to separate pump head from pump body.

With a narrow punch, drive lever pin out until pump lever is loose. Pin may then be driven in either direction, but need not be removed entirely. Remove old diaphragm, but leave diaphragm spring in pump body.

Place new diaphragm into pump body with the slot in shaft at right angles to the pump lever. Diaphragm spring should fit into the cup under the diaphragm. Without the lever spring, insert the pump lever into body holding the diaphragm down. Fit the hook at the end of lever into the slot in diaphragm shaft. Fig. 59. Ill. 1.

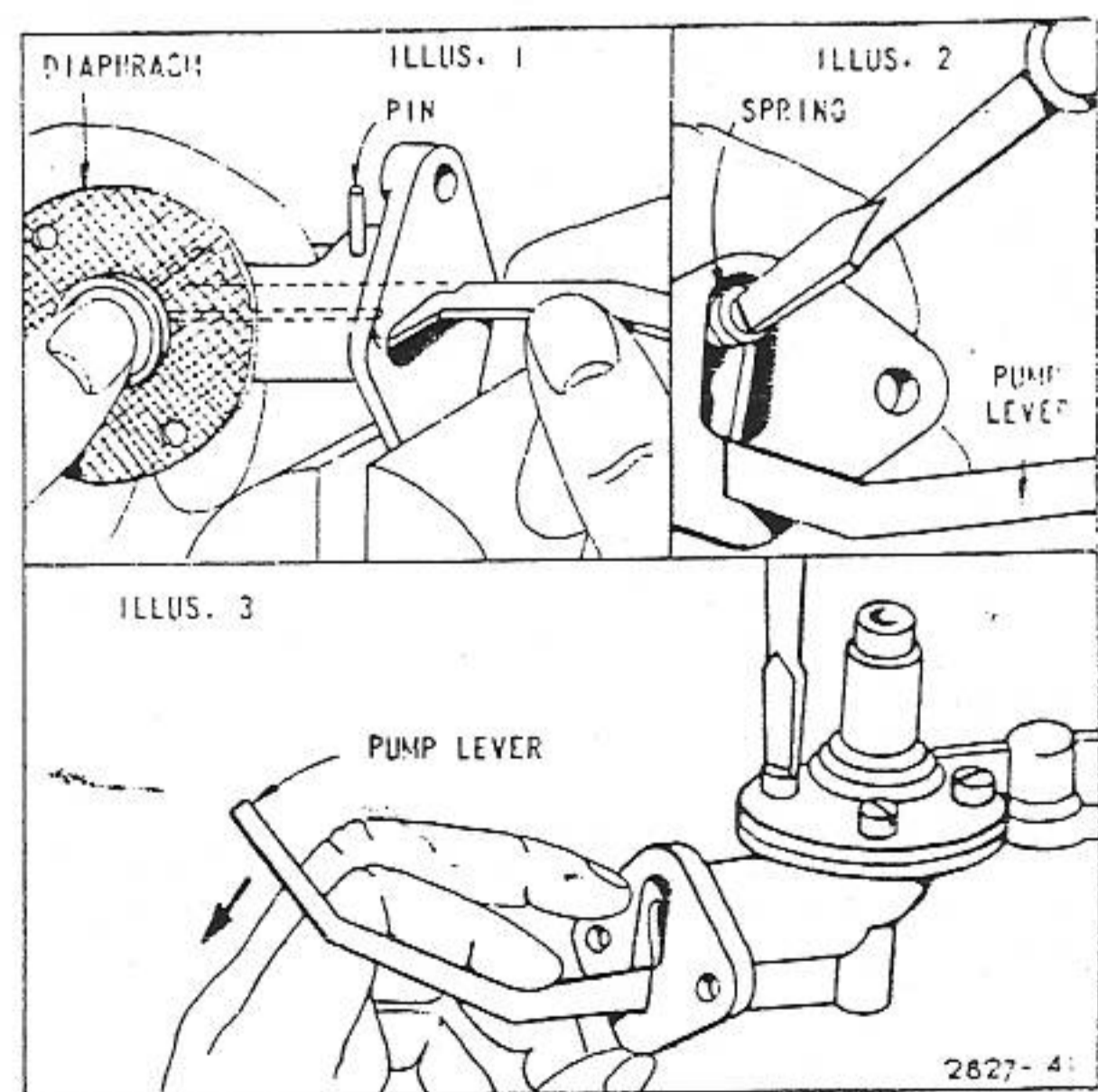


FIG. 59—FUEL PUMP

Align holes in lever and body, then drive lever pin into place. Place lever spring into body with inner end of spring over the projection in pump body, then use a screw

driver to force outer end of spring into body until it slips over the projection on lever. Fig. 59. Ill. 2. Place pump head on body and partially insert the four screws. Press pump lever down as far as possible and then tighten the four screws securely. Fig. 59. Ill. 3.

## GOVERNOR

The purpose of the governor is to maintain—within certain limits—a desired engine speed even though the load may vary. The governor spring pulls throttle open, while governor action closes throttle. The speed at which these two forces are balanced is the governed speed. The term engine speed as used herein, indicates the R.P.M. when operating under control of the governor and does not include idling speeds.

Two different types of governors are used:

1. **MECHANICAL GOVERNOR.** This is a centrifugal type operated by the cam gear and is linked to the carburetor throttle. Fig. 60.

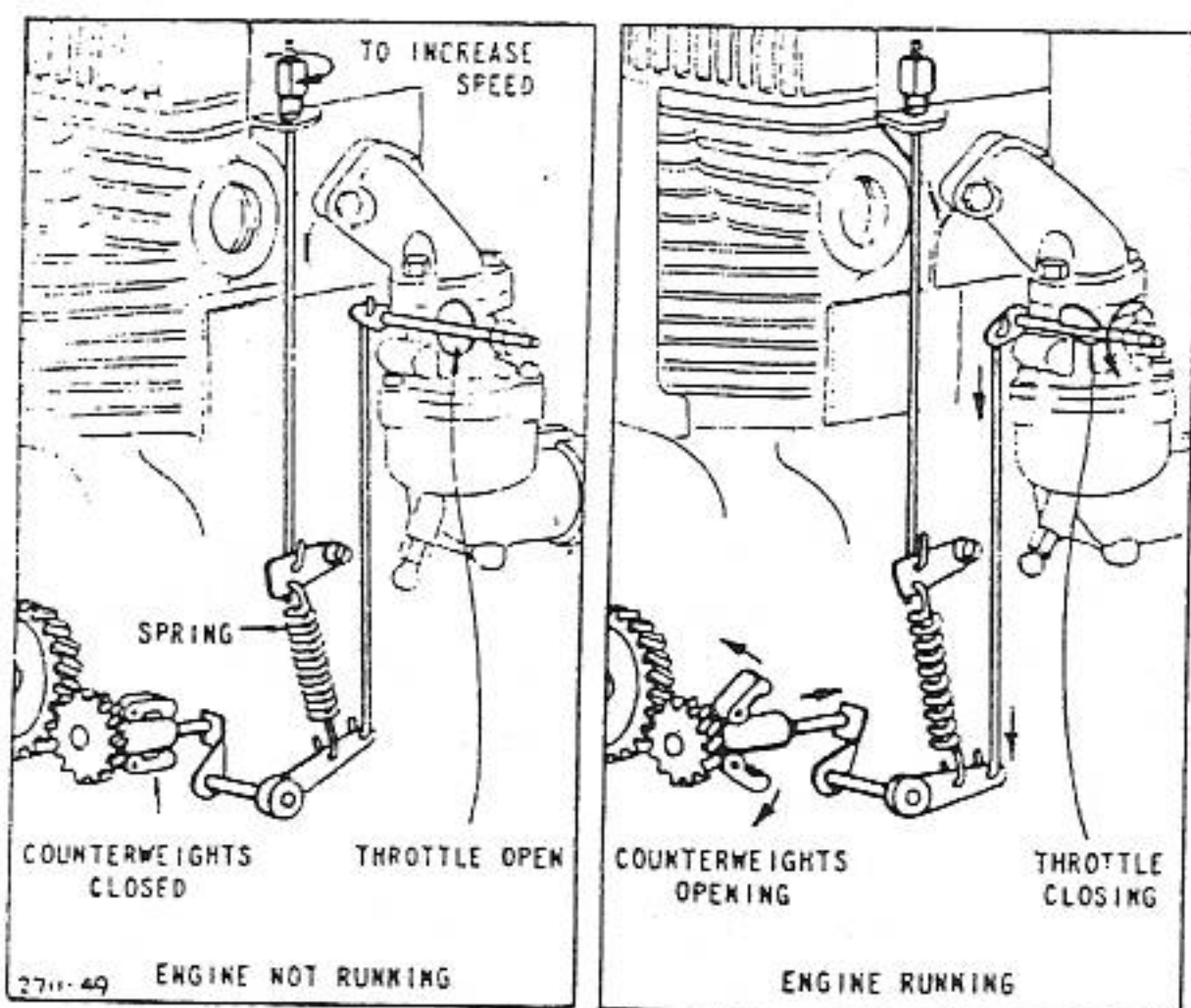


FIG. 60—MECHANICAL GOVERNOR

2. **PNEUMATIC GOVERNOR.** This operates by air pressure from the flywheel against an air vane which in turn is linked to the carburetor throttle.

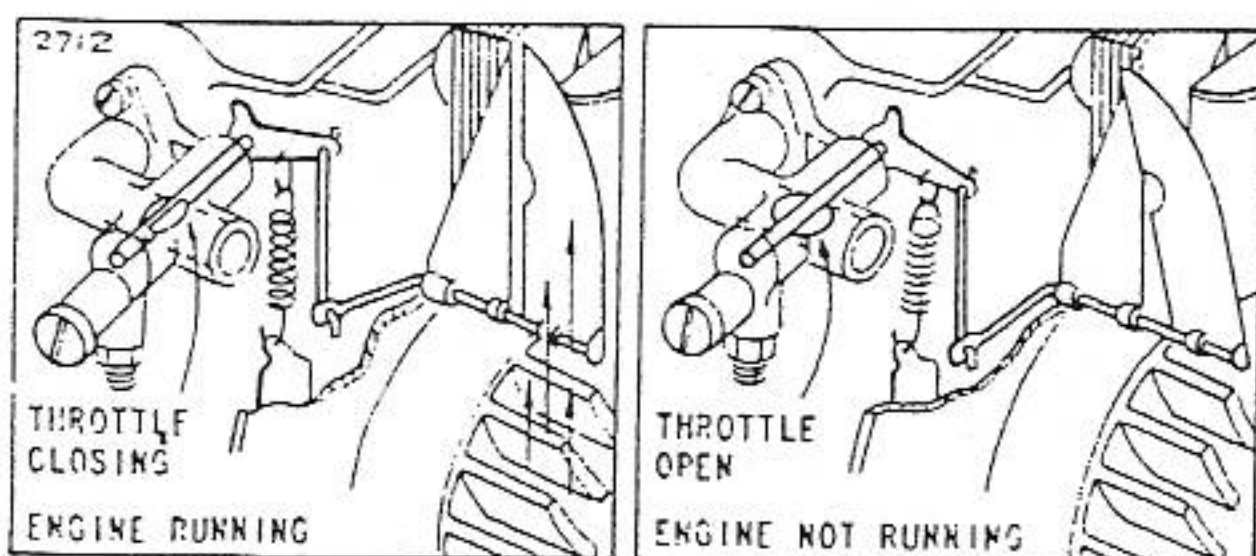


FIG. 61—PNEUMATIC GOVERNOR

### To Set Governor for Correct Engine Speed

First check table No. 4 or 5 to determine the correct engine speed. Then, with the engine running, increase or decrease the tension on the governor spring (or throttle spring) until the desired speed is obtained. A tachometer should be used for checking the engine speed.

### To Adjust Mechanical Governor Models A-B-FJ-K-L-M-R-S-T-W-Z-ZZ

If the governor lever has become loosened or removed from the governor shaft, reset as follows:

Loosen screw holding lever on the governor crank. This should be done with the carburetor attached to the engine and hooked up to the governor lever with throttle link.

Push the governor lever counter-clockwise as far as it will go. Hold in this position and turn the governor crank clockwise with pliers as far as it will go. Tighten screw that holds governor lever to the crank until it is snug, but not tight. Push governor lever clockwise as far as it will go and tighten screw securely.

### Models 9-14-23

Loosen screw holding governor lever to governor crank. Push the lever clockwise as far as it will go. Hold it in this position and turn the governor crank counter-clockwise as far as it will go. This can be done with a screw driver. Tighten the screw that holds the governor lever to crank until it is snug, but not tight. Now push governor lever counter-clockwise as far as it will go, then tighten screw securely. These instructions are the same as Models A-B, etc. above, except that the movements of lever and crank are exactly the opposite.

### Models I-N

There is no adjustment between governor lever and governor crank on these models. However, governor action can be changed by inserting governor link or spring in different holes of governor and throttle levers. Fig. 62. In general, the closer to the pivot end of the lever, the smaller the difference between load and no load engine speed. The farther from the pivot end, the steadier the governing will be while engine is running under load and the easier to eliminate throttle hunting. The standard setting is shown in Fig. 62.

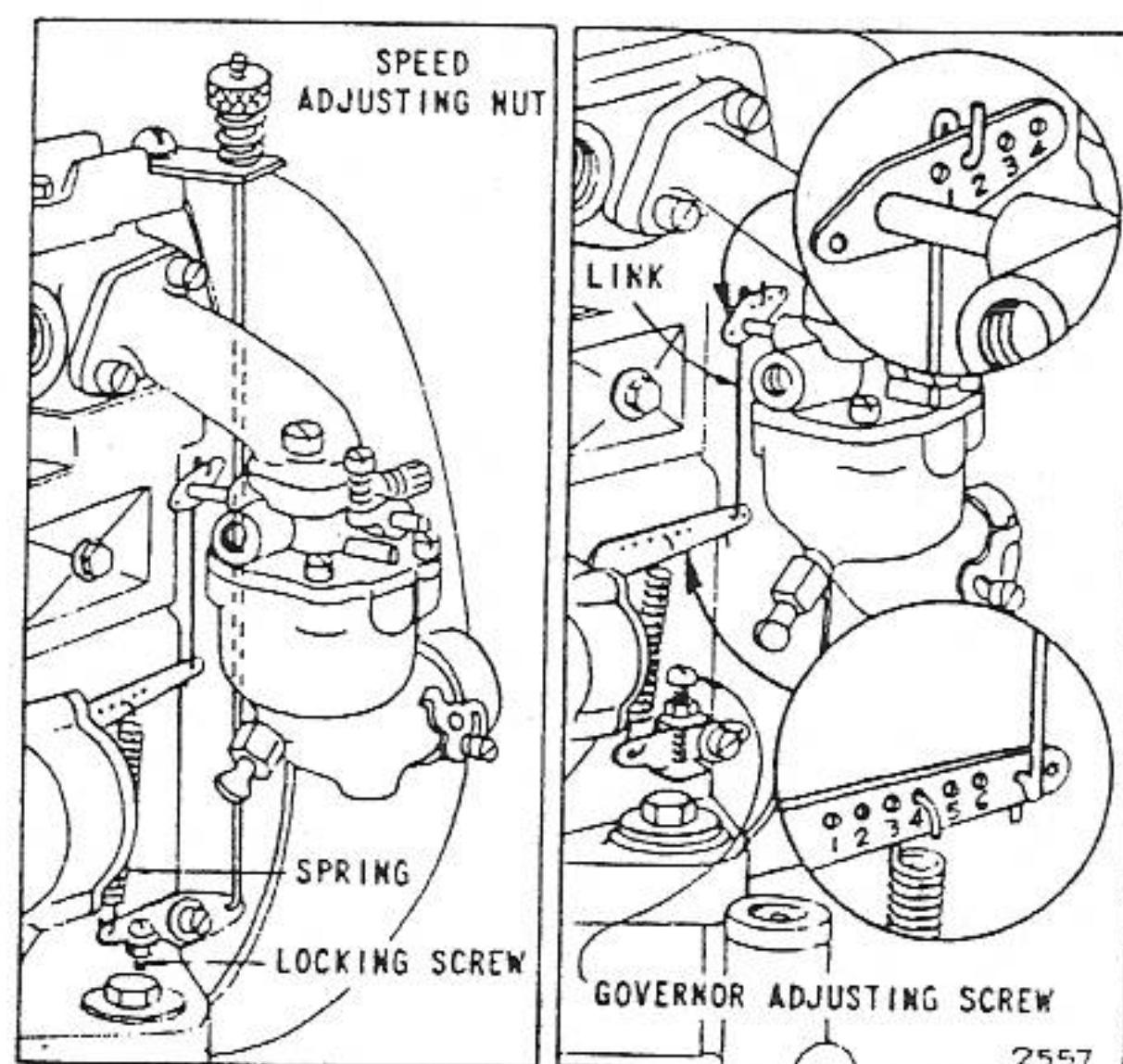


FIG. 62—GOVERNOR ADJUSTMENT

fit on shaft so that gear may revolve freely but does not wobble. Be sure air relief hole is open. Fig. 67.

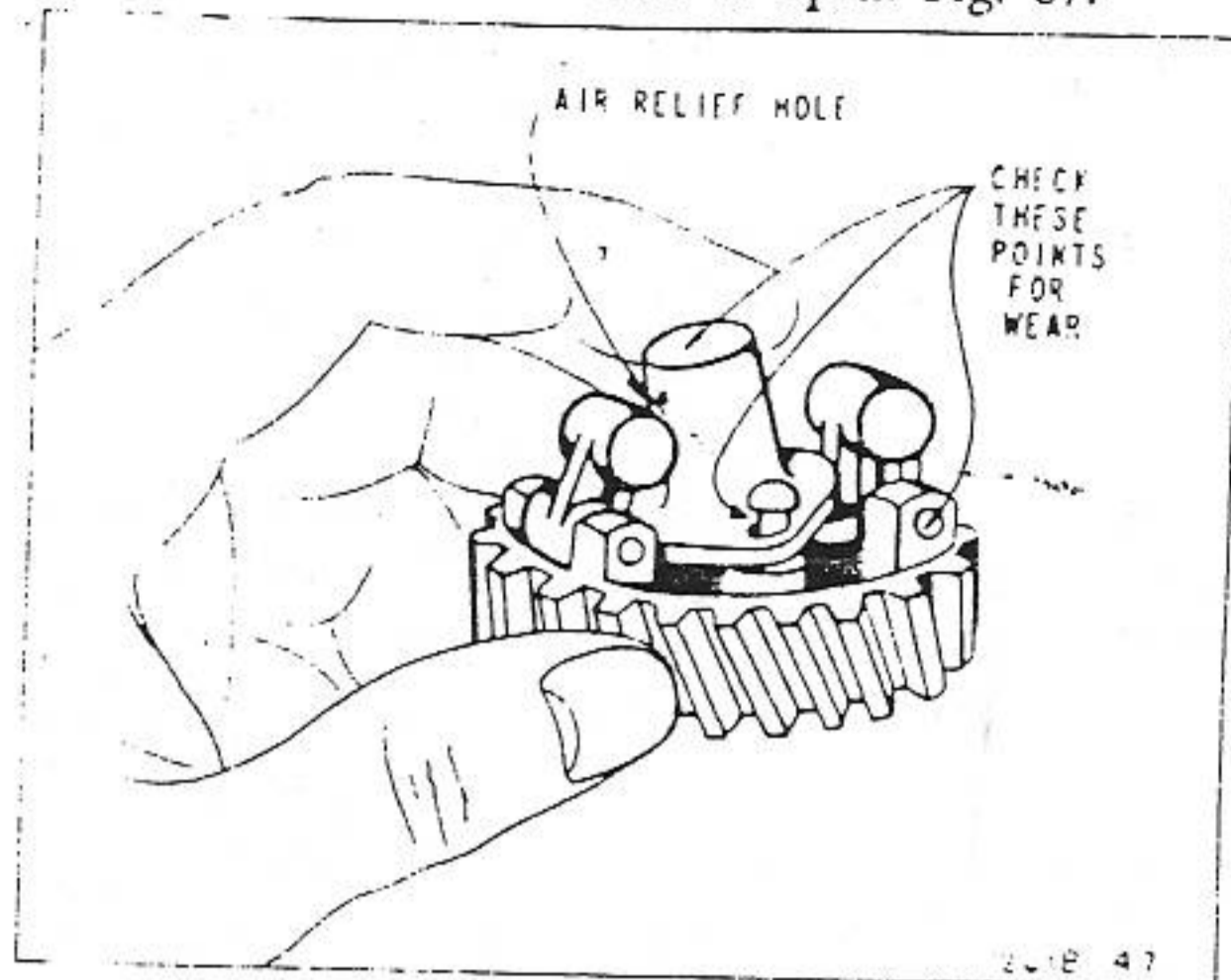


FIG. 67—GOVERNOR GEAR

### To Replace Governor Gear Shaft

The shaft on most models can be pressed into place from the outside at the same time driving out the old shaft. Exceptions are as follows:

#### Models 9-14-23

The old governor shaft should be driven inwards with a small punch. The new shaft must be installed from inside the crankcase. The outer end of the shaft should be flush with the cylinder. The same shaft, part No. 291177, is used on Models 9-14-23.

#### Models L-M-R-S-T

The governor shaft is held in place with two screws.

## REMOTE GOVERNOR AND THROTTLE CONTROLS

The various remote controls for each model are shown in Fig. 70 to 108 and should be assembled as shown. In general, there are two types of remote controls. (1) Governor Control and (2) Throttle Control.

### Remote Governor Control

This control regulates the engine speed by changing the governor spring tension, thus allowing the governor to control the carburetor throttle at all times and maintain any desired speed. Fig. 68.

### To Adjust Remote Governor Control

Start engine, loosen screw in swivel on control lever. Move control lever to high speed position. Fig. 68. Pull control wire through control casing and swivel on control lever until the maximum speed is obtained. Retighten control wire screw, bend loose end of wire around swivel and cut off excess wire.

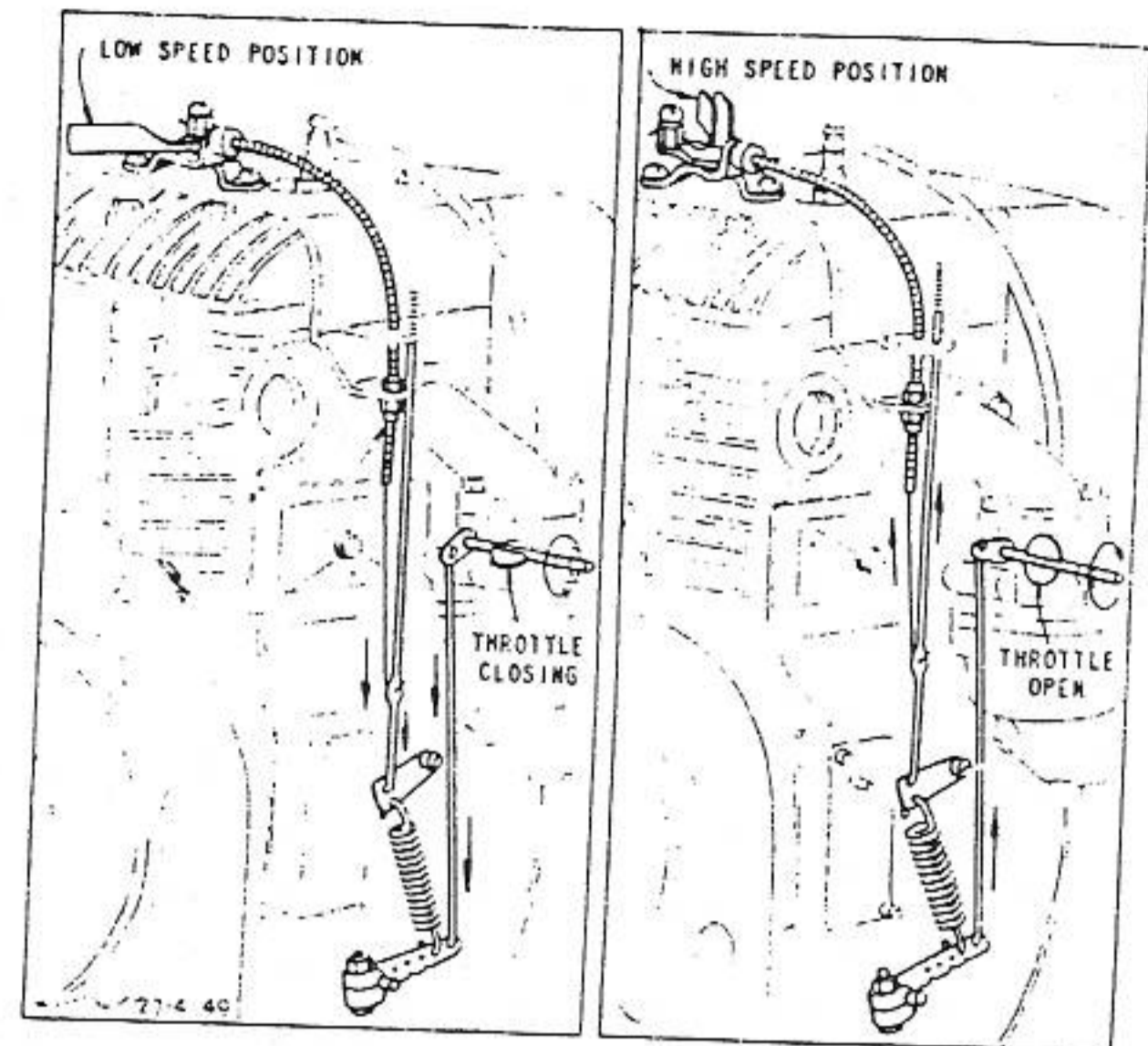


FIG. 68—REMOTE GOVERNOR CONTROL

### Remote Throttle Control

This is connected to the governor lever and operates the carburetor throttle until the full governed speed is obtained and at which point the governor takes over control of the throttle. At any point below the governed speed, the throttle will be held in fixed position and the engine speed will vary with the load. Fig. 69.

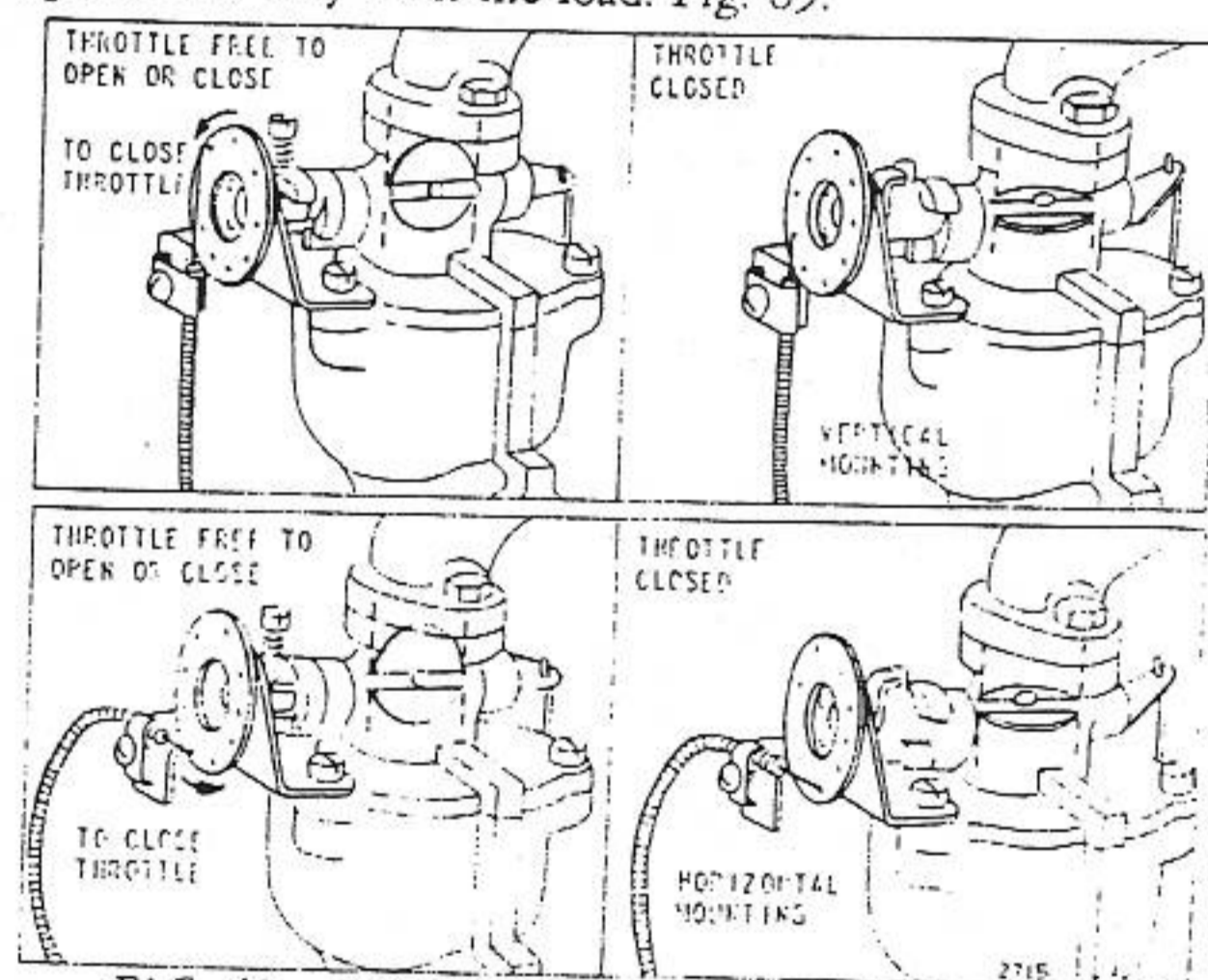


FIG. 69—REMOTE THROTTLE CONTROL

### To Adjust Remote Throttle Control

Move the control lever to the low speed position. Fig. 69. Loosen the control wire screw and pull wire through the casing and swivel until the carburetor throttle is closed. Retighten control wire screw. Check by moving control lever to high speed position. The carburetor throttle should now be free to open or close completely.

**To Adjust Pneumatic Governor**

The bracket which carries the bearings fits the armature with no more than 1/16" space between the free side and the mounting Fig. 63. Ill. 1. This should be parallel with the mounting surface. If the position of the bracket is not so, it should be bent back into position.

The governor shaft bearings must be in alignment and a free fit on the shaft. Fig. 63. Ill. 2. If they have been forced out of line, the bracket must be straightened or the bearing enlarged to restore free movement. The governor vane should be checked for clearance of both edges so that it does not touch either the bracket or the blower housing. To restore clearance throughout the vane travel, it may be necessary to straighten the bracket and shaft.

The vane should stop at from 1/8" to 1/4" from the magneto coil when assembled and linked to the throttle shaft. Fig. 63. Ill. 3. This may be adjusted by springing the vane carefully in the direction indicated while holding the shaft. If the soldered joints have been broken loose, they may be resoldered to produce the above mentioned position with closed throttle.

As viewed from the blower side, the wire link connecting the governor arm to the carburetor throttle lever should stand in a practically vertical position when the throttle is wide open. Fig. 63. Ill. 4. Use either hole in governor arm to obtain this vertical position. If the above adjustments have been made and the upper end of link binds on the throttle lever, it may be relieved by prying the lower end of the link outwardly until the link bends slightly and binding is eliminated. Fig. 63, Ill. 5.

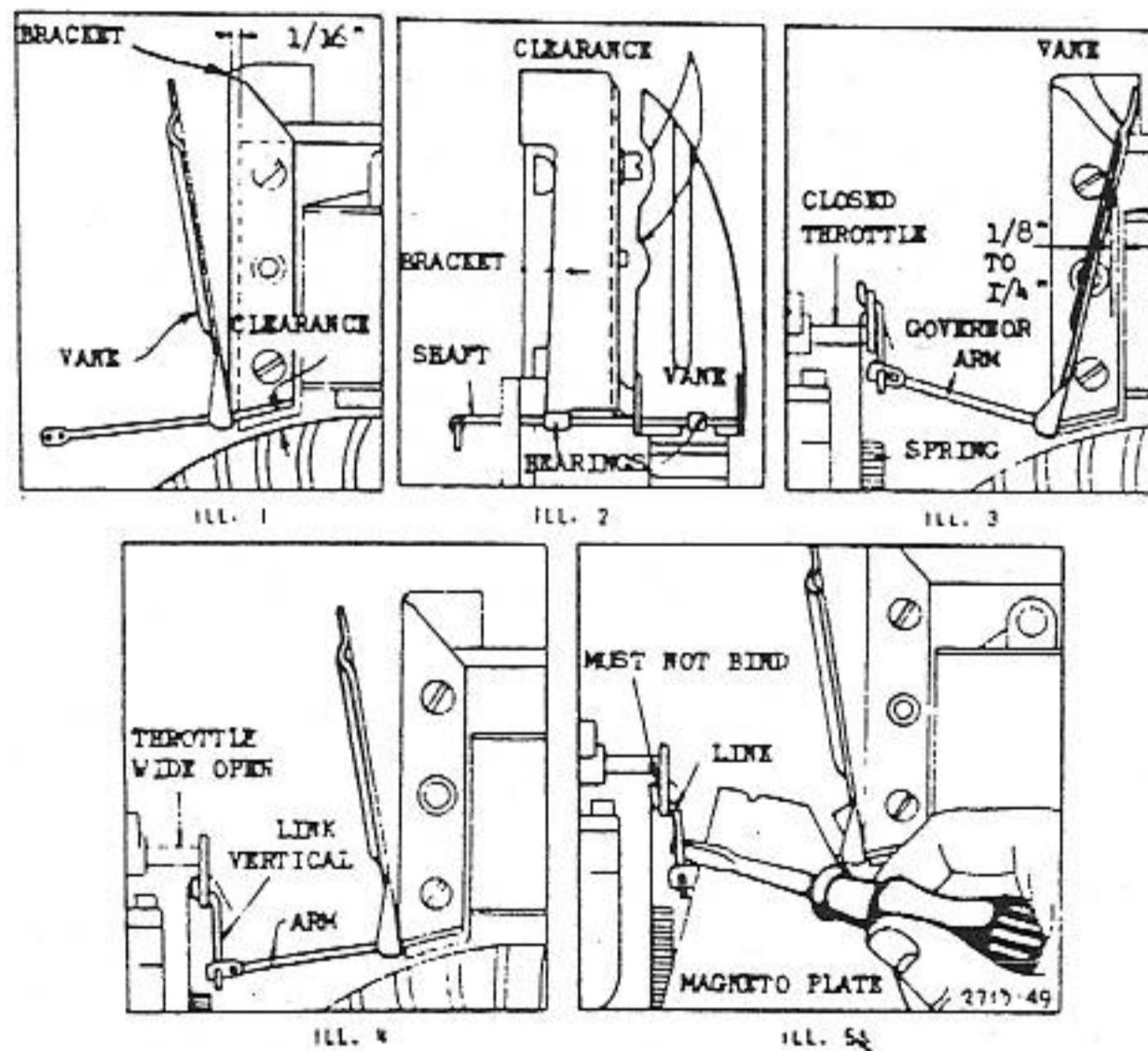


FIG. 63—ALIGNING GOVERNOR PARTS

**Mechanical Governor Parts**

Inspect governor parts for wear. Worn parts can cause throttle hunting or even complete failure of the governor to function.

If a hole is worn in the flat face of the governor crank, it should be discarded as this will cause jerky, uneven action and result in throttle hunting. Fig. 64. The governor plunger wears at both ends. The ends should be round and smooth.

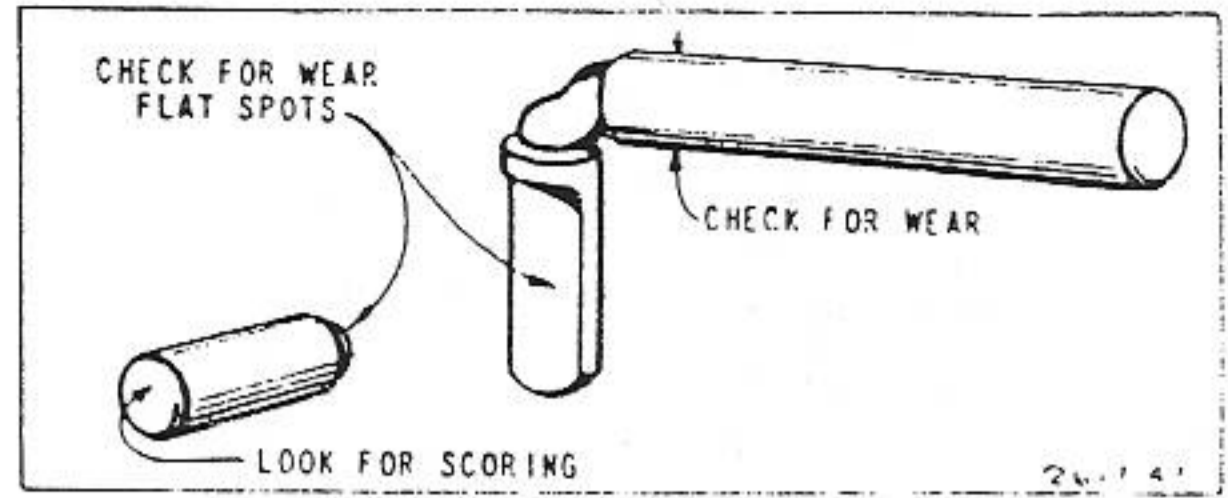


FIG. 64—GOVERNOR CRANK AND PLUNGER

Check the tangs on the governor weights. They should be square and smooth. If a tang is broken, the governor will not operate. If weights bind or stick, the gear should be replaced. Fig. 65. The shaft hole in the governor gear may be checked with a new shaft.

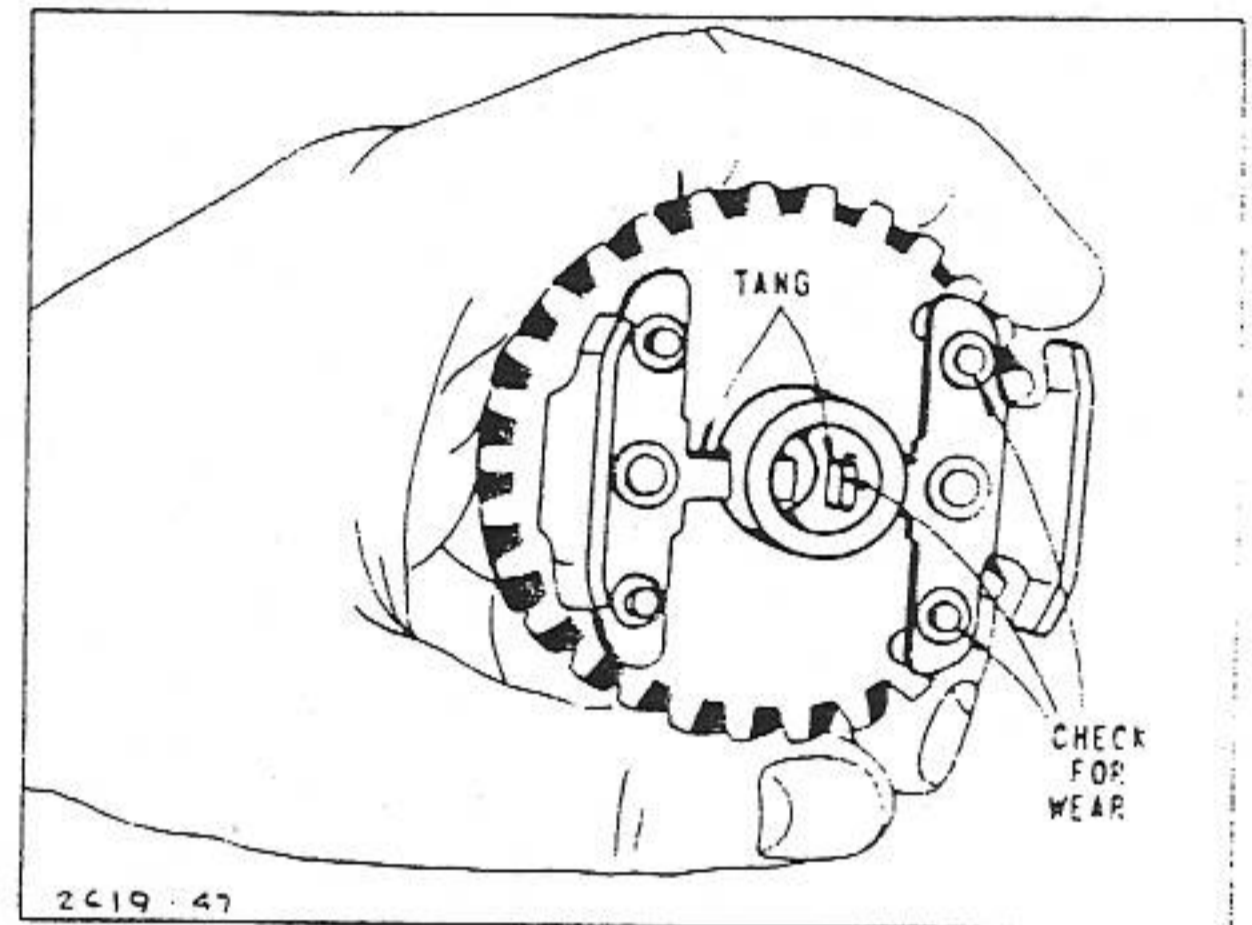


FIG. 65—GOVERNOR TANGS

The governor crank should fit the bushing freely, but not loosely. Use a new crank to test bushing and rebush if necessary. It will be necessary to ream the bushing after pressing it in. Use an expansion reamer and ream just enough so that crank moves freely.

Check the holes in the governor link, the pins on the governor lever and on the carburetor throttle lever. Much of the governor action can be lost taking up the slack due to wear at these points. Fig. 66. CAUTION: Be sure to use crankcase support while replacing either governor shaft or bushing. Failure to do so may result in cracked or broken crankcases.

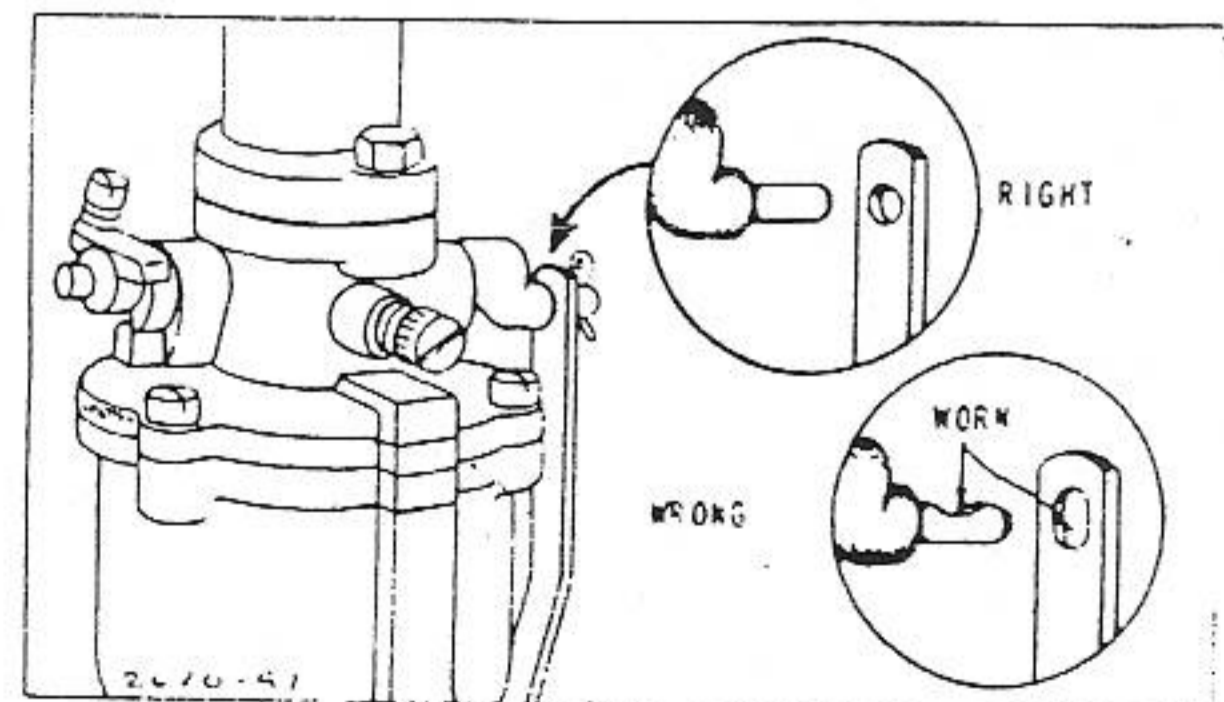


FIG. 66—GOVERNOR LINK

**Model A**

The governor bushing is threaded and must be removed before gear can be removed from shaft. The gear should

CARBURETOR AND GOVERNOR CONTROLS

Fig. 70 to 108 show governor linkage and remote control hook-up for the various engine models.

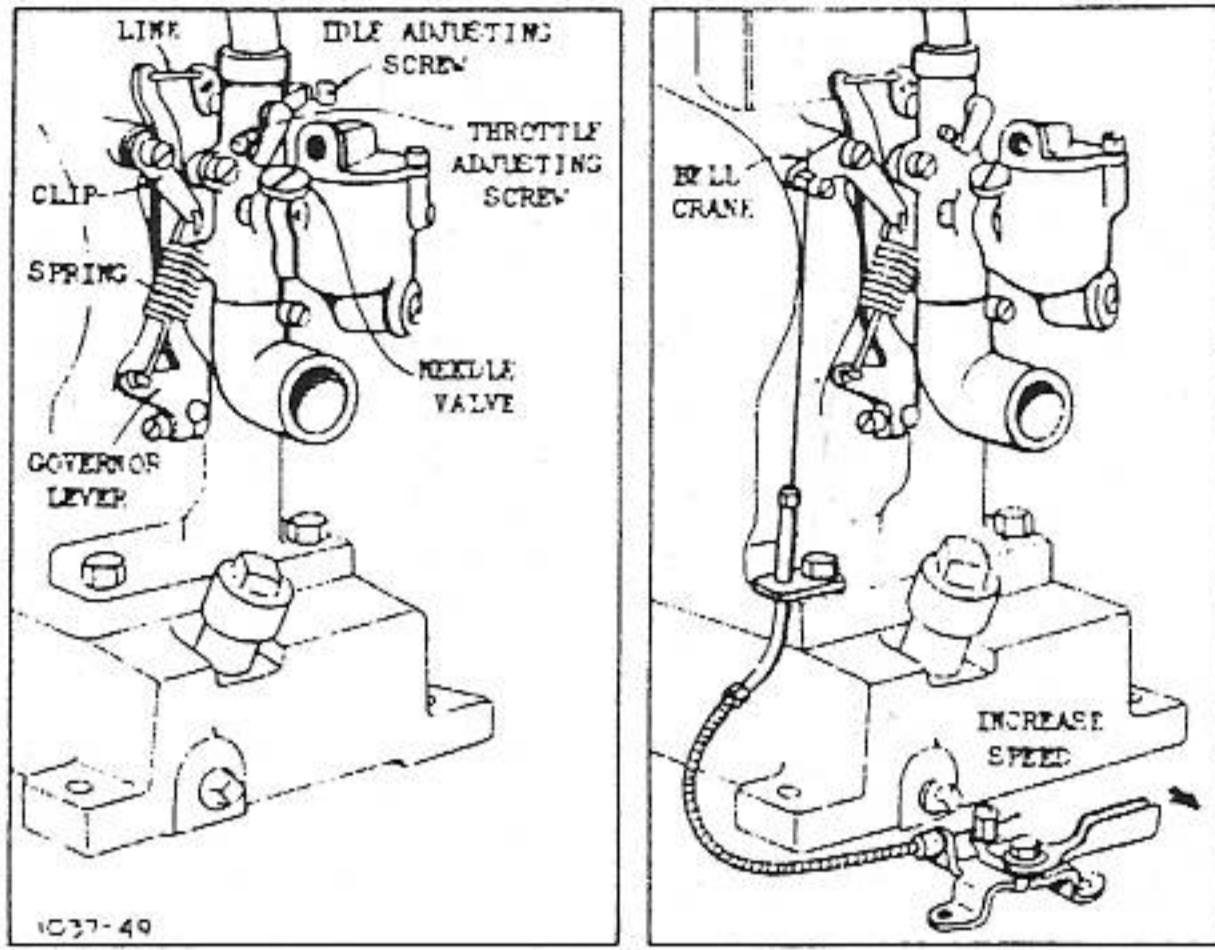


Fig. 70—Models A-FJ-M-T 5 Digit

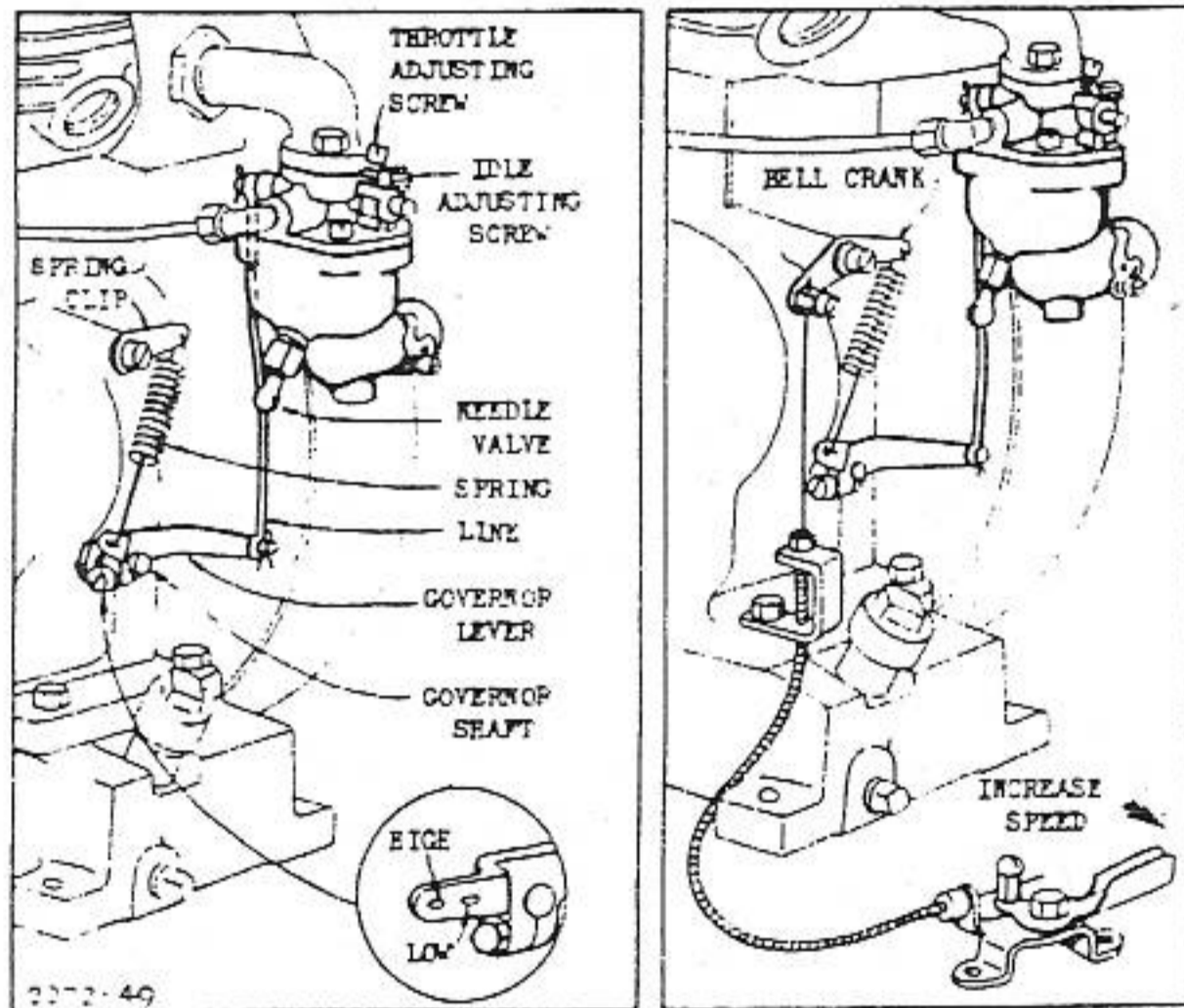


Fig. 71—Model A 6 Digit

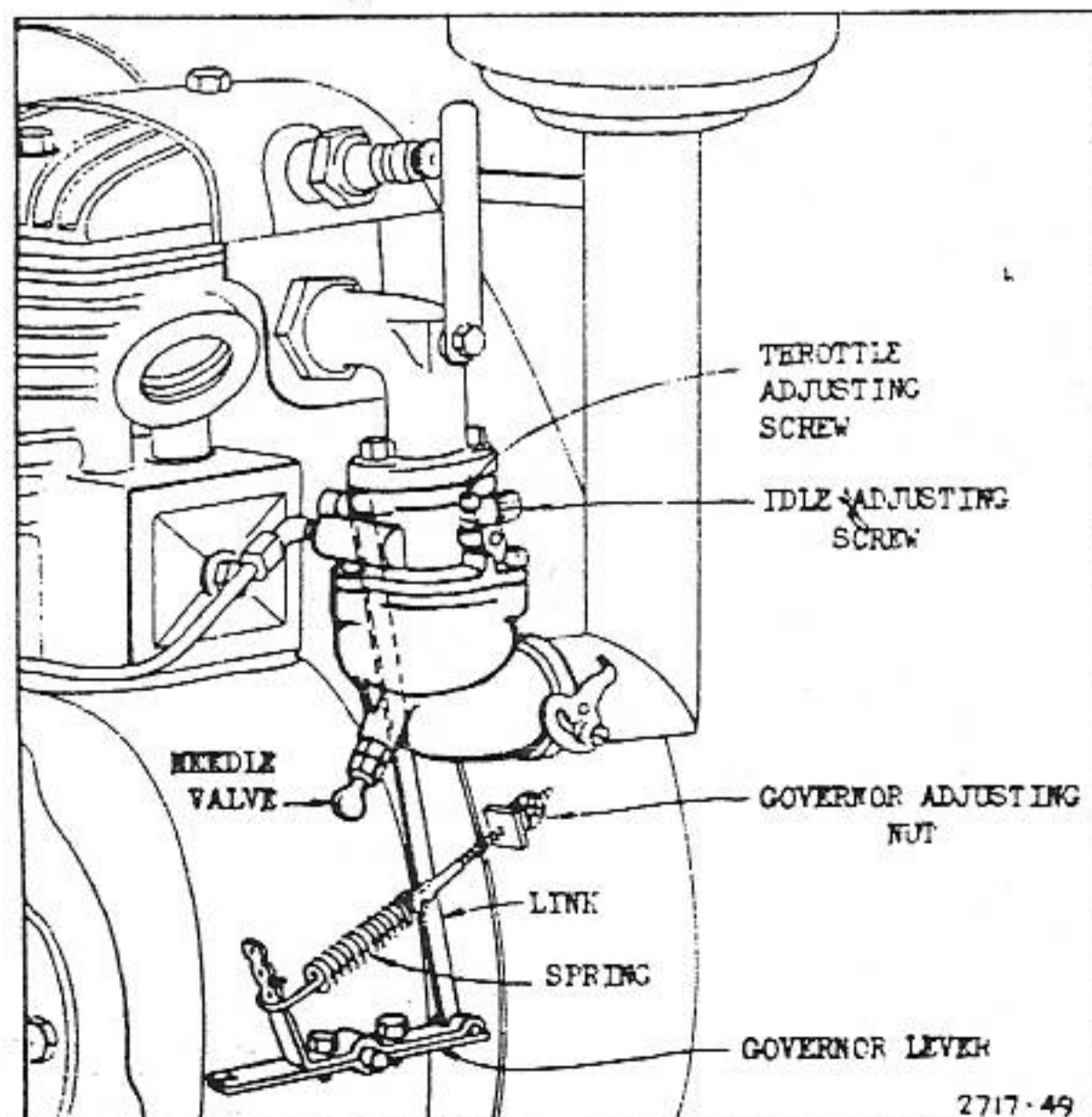


Fig. 72—Models B-K-Z-ZZ

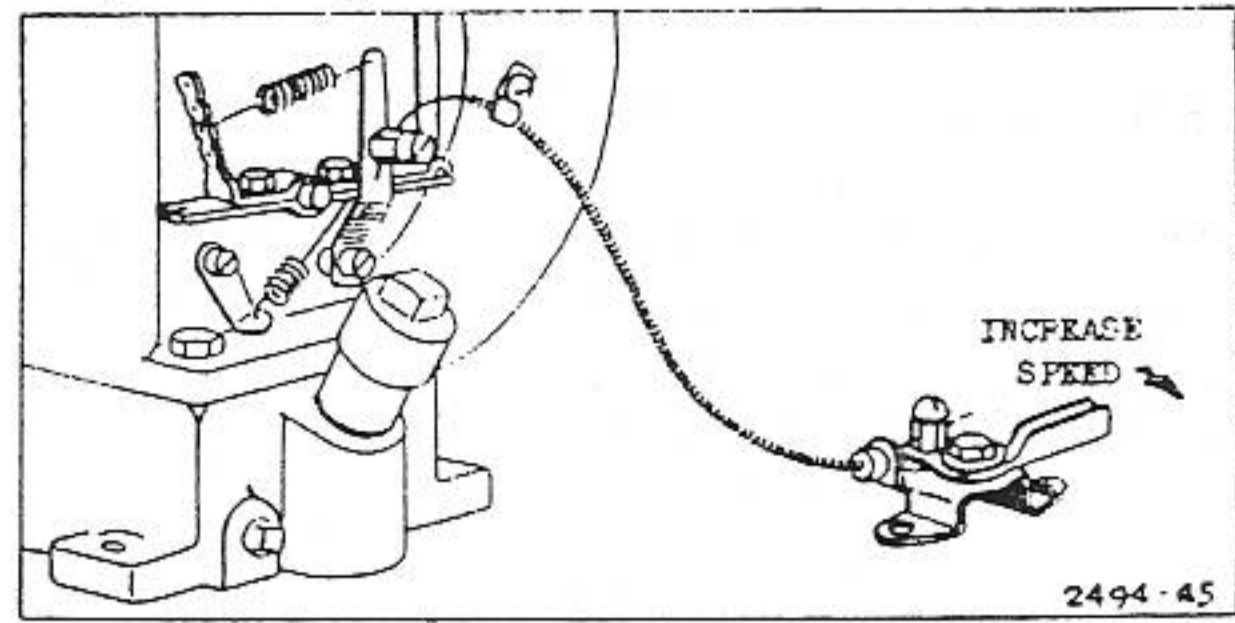


Fig. 73—Models B-ZZ Remote Gov. Control

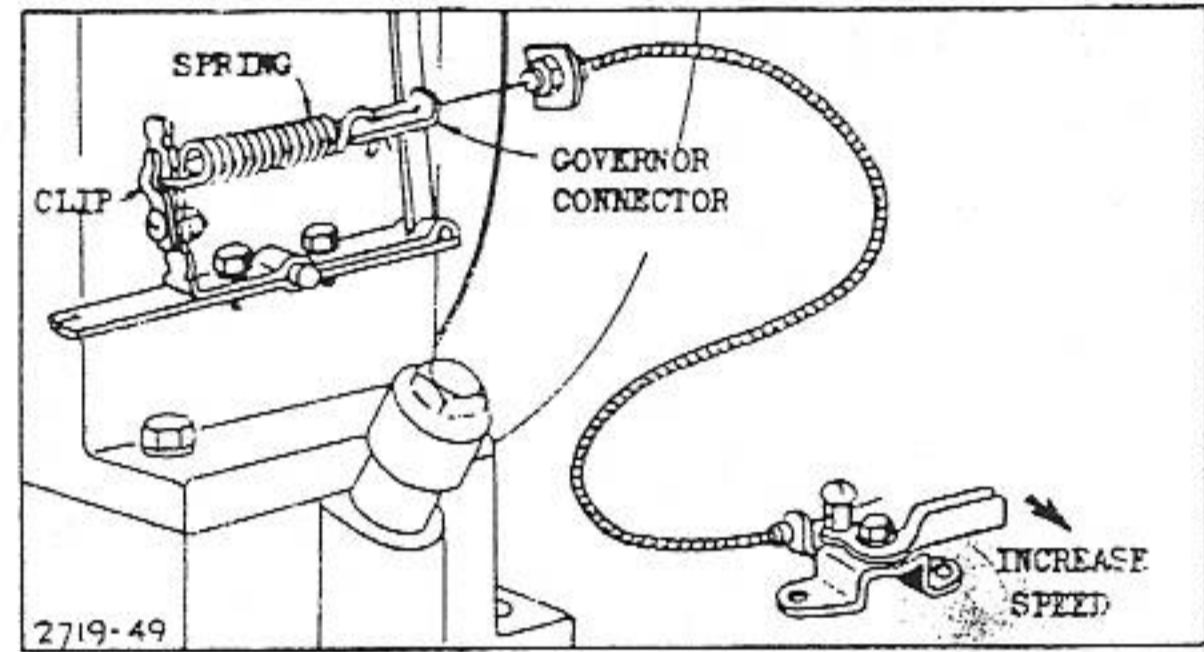


Fig. 74—Models B-ZZ Remote Gov. Control

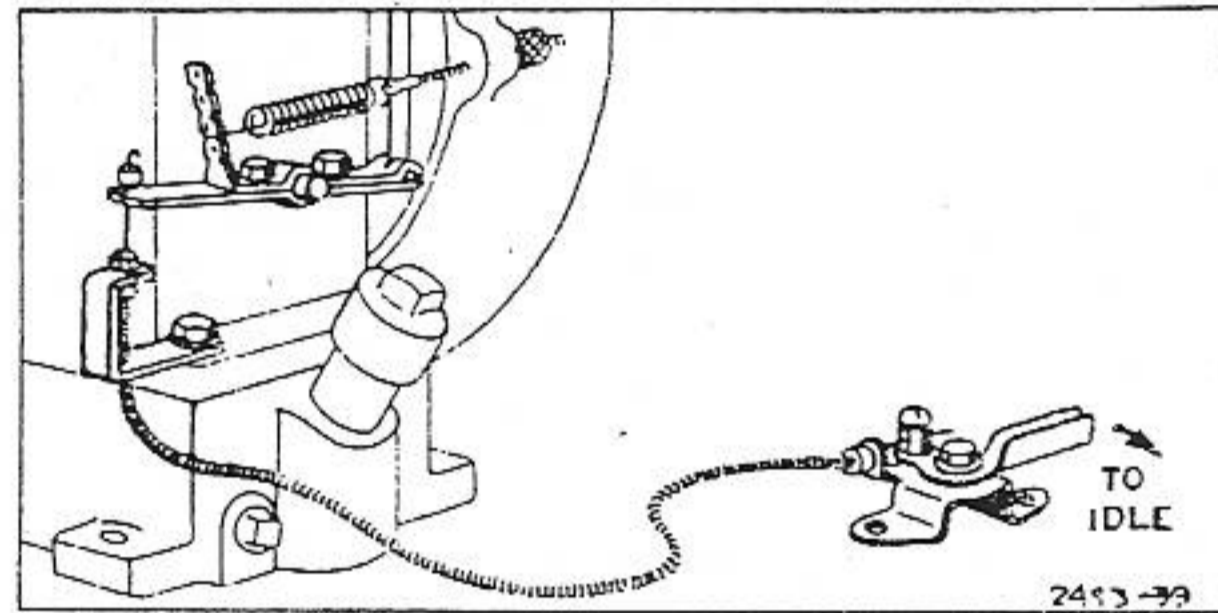


Fig. 75—Models B-ZZ Remote Throttle Control

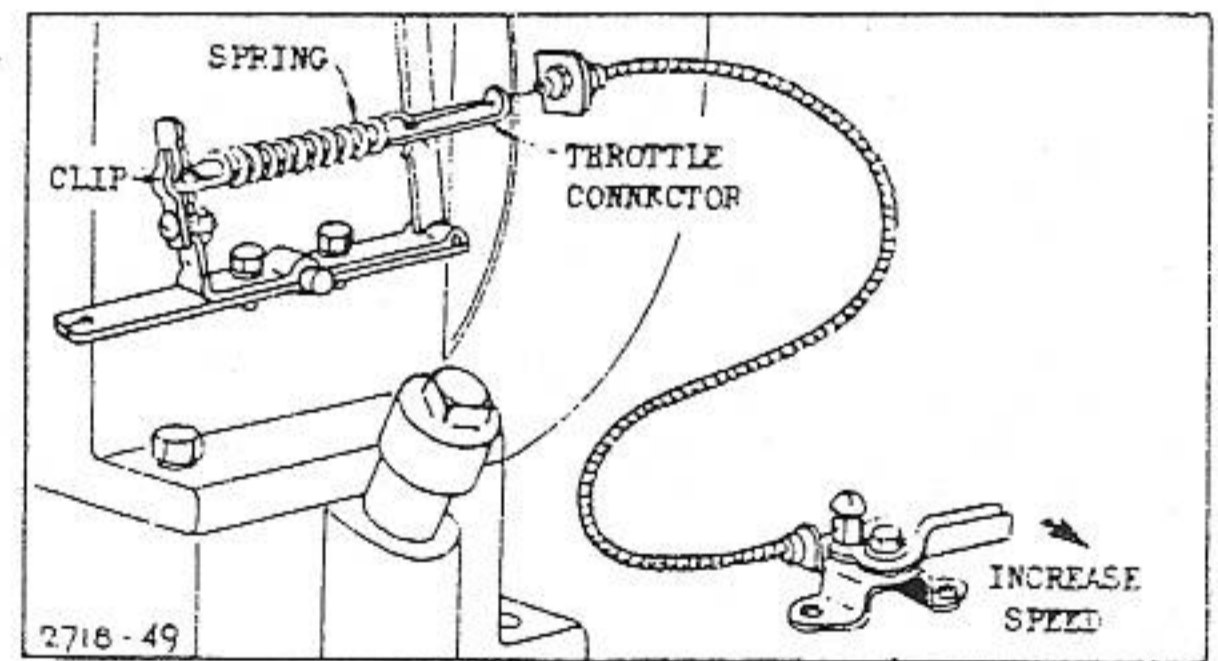


Fig. 76—Models B-ZZ Remote Throttle Control

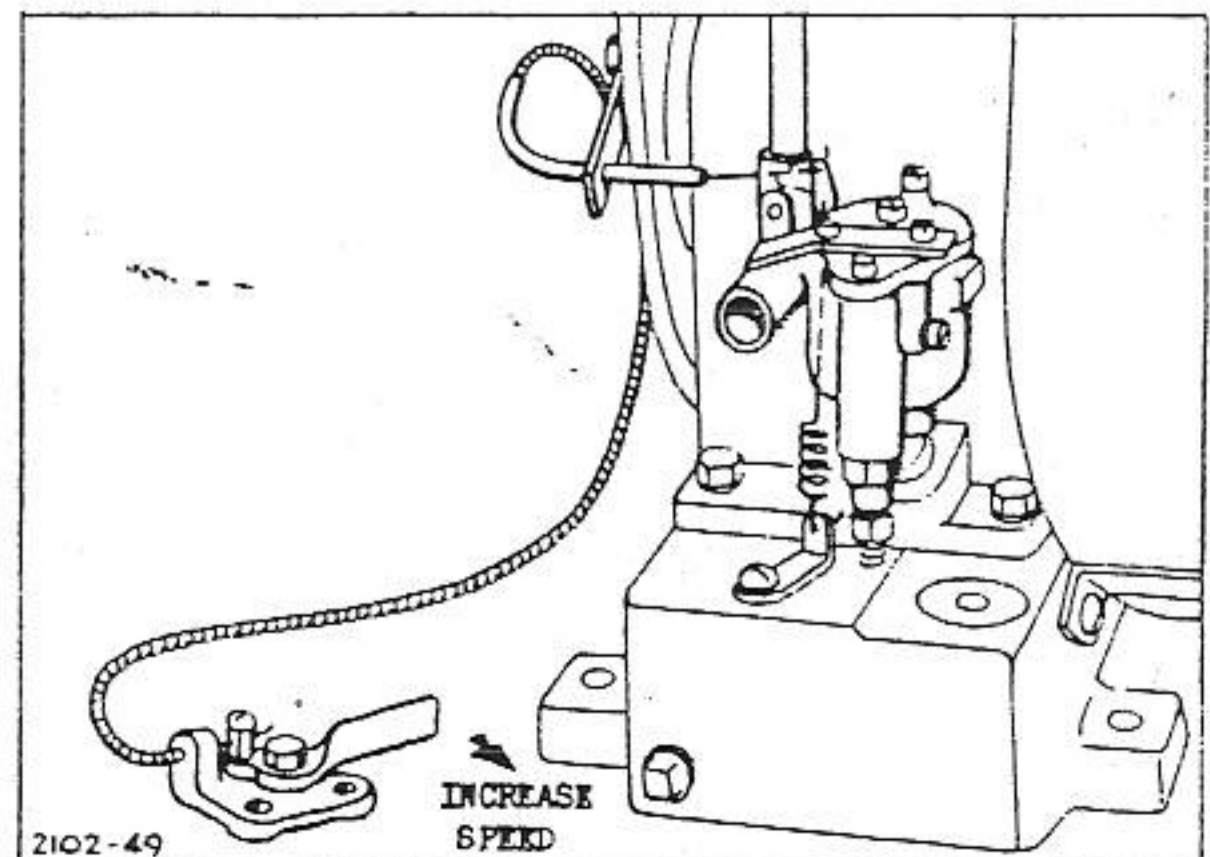


Fig. 77—Model FH1

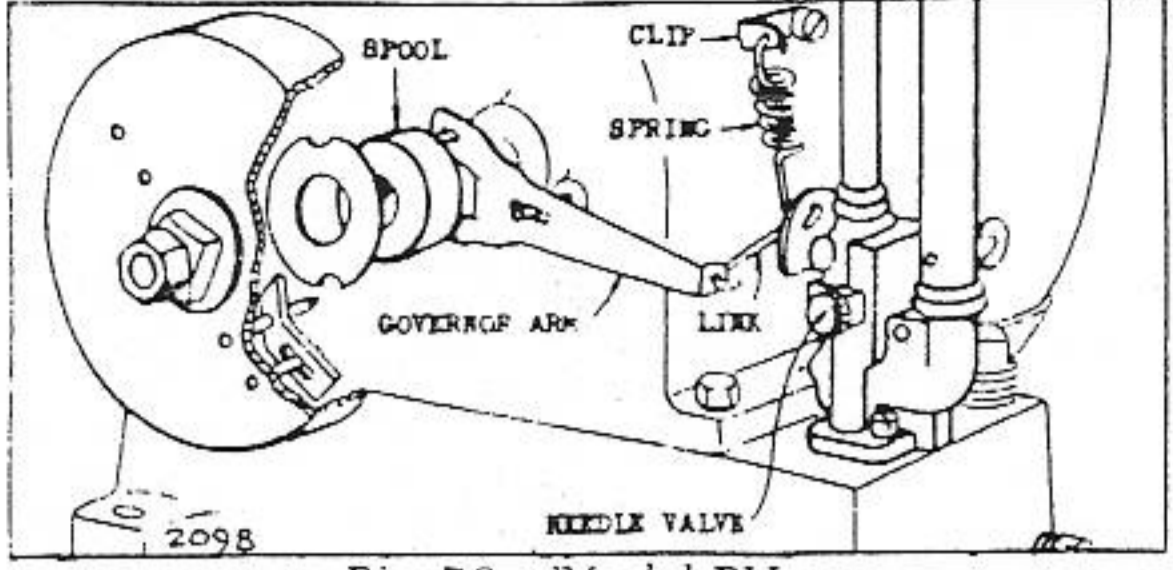


Fig. 78—Model FH

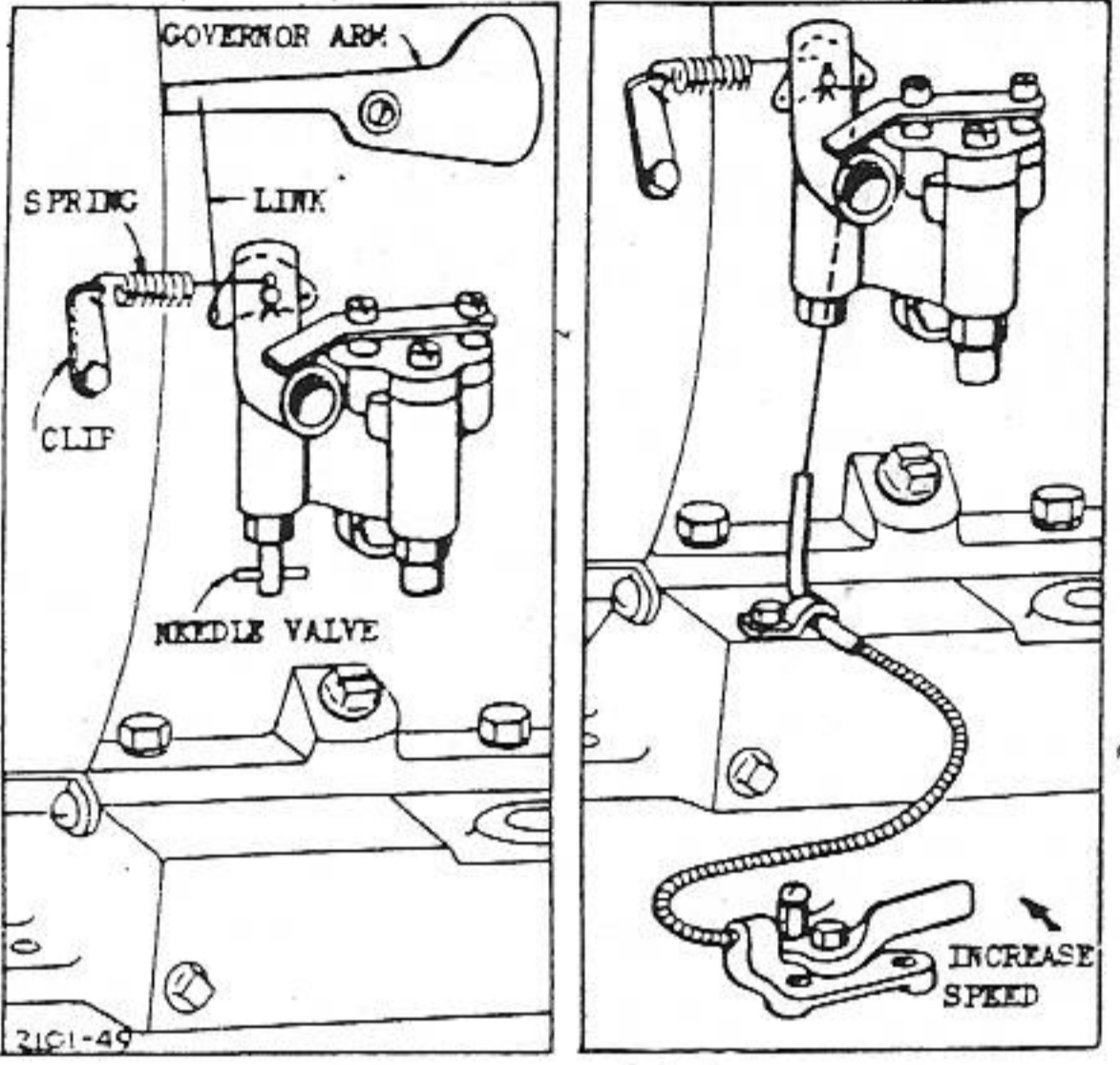


Fig. 79—Model FI

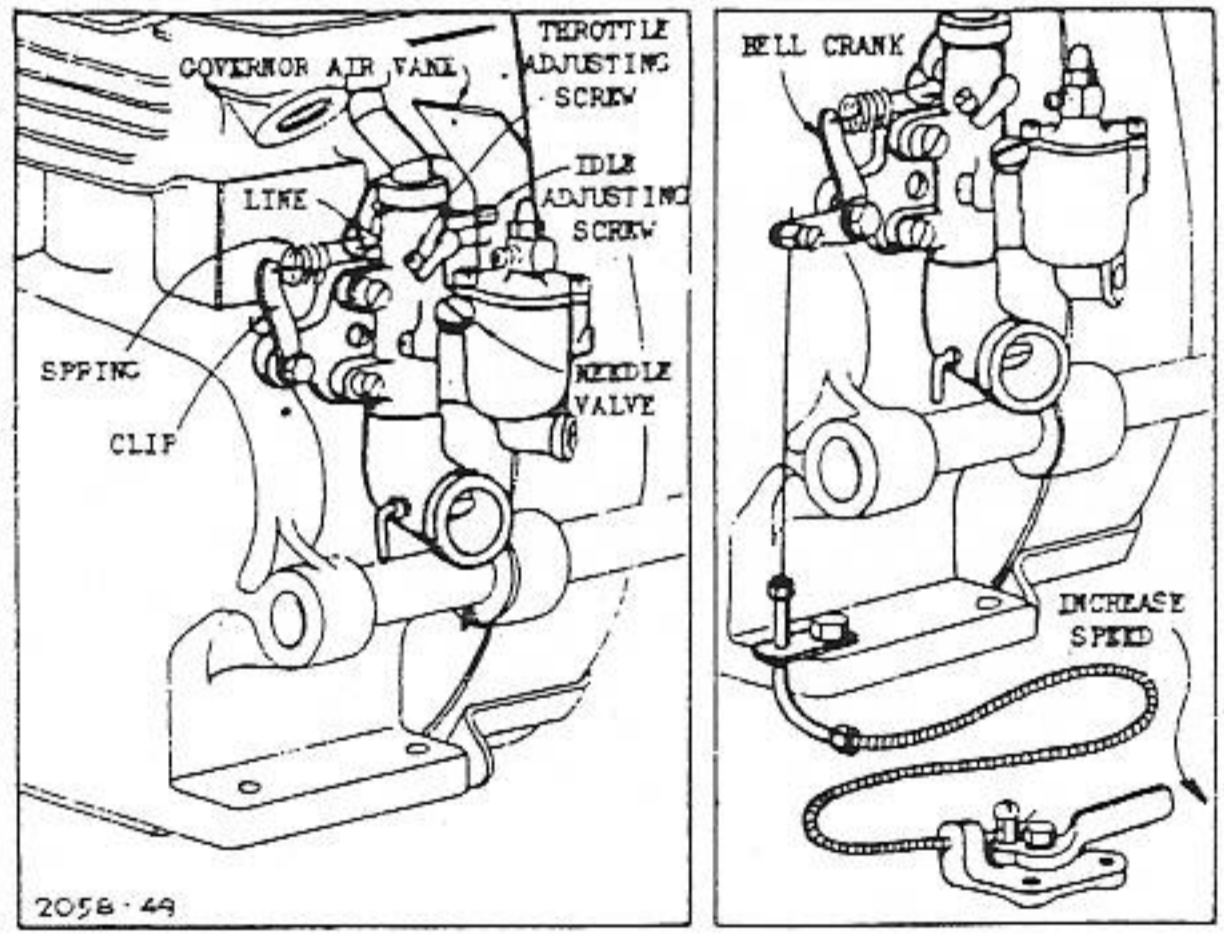


Fig. 80—Model H

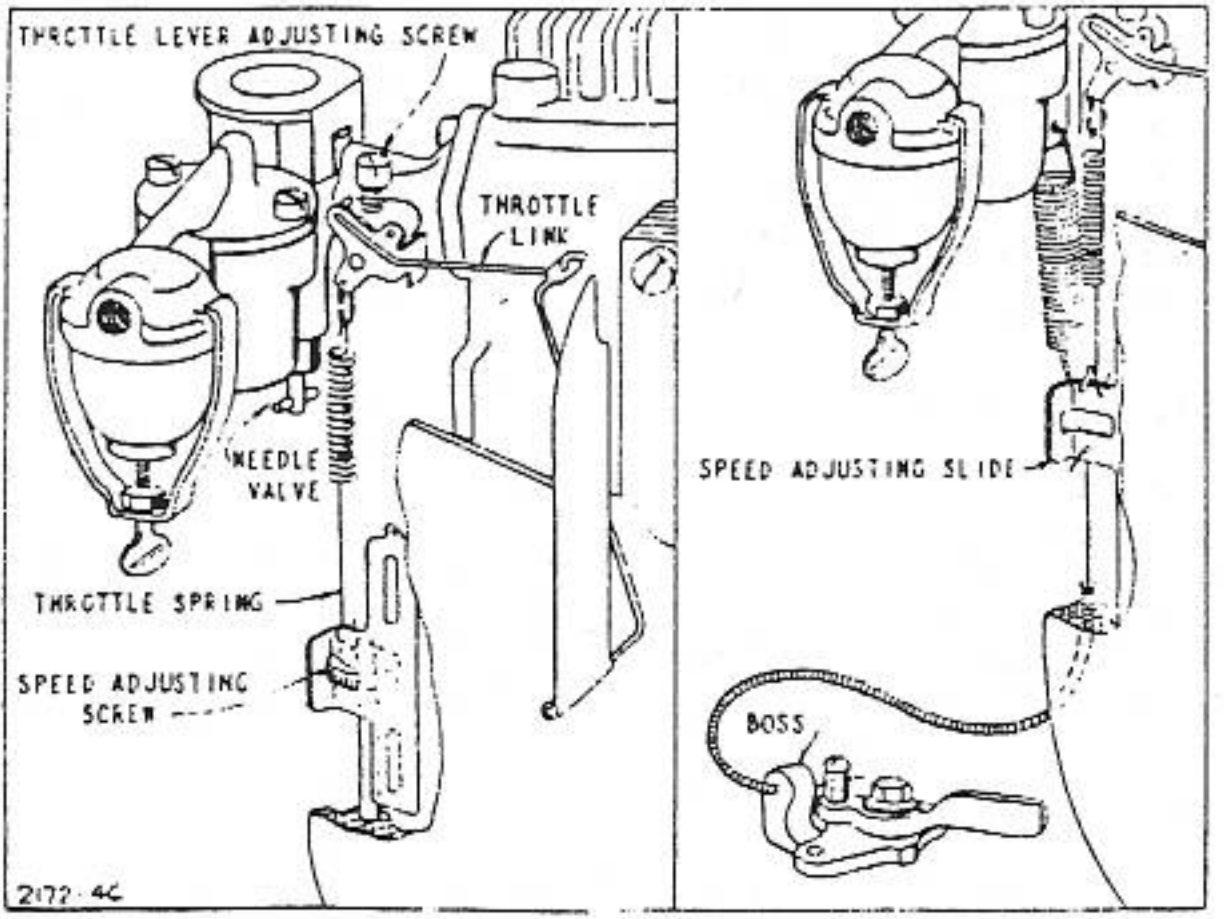


Fig. 81—Models I-IBP 5 Digit

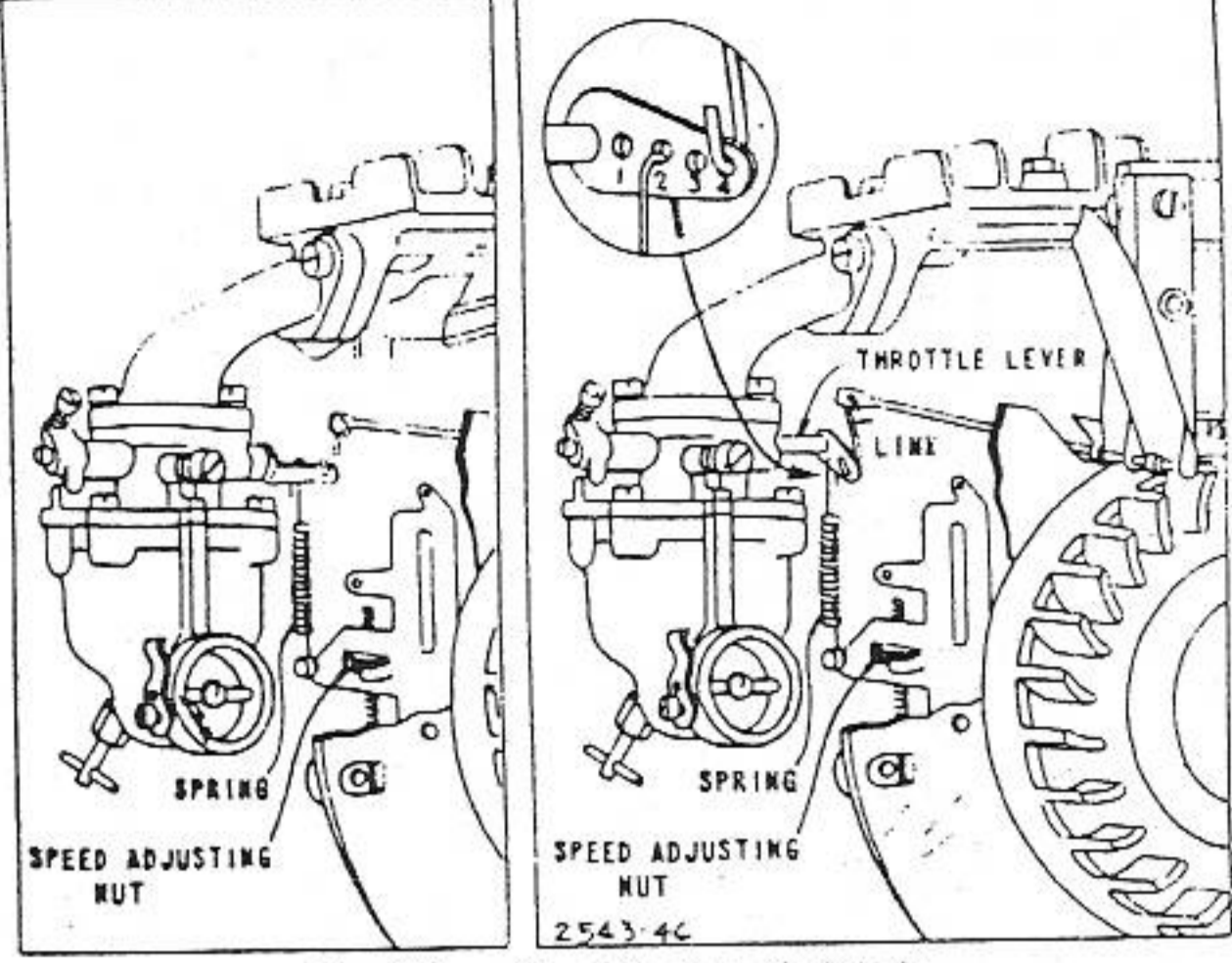


Fig. 82—Models I-5 6 Digit

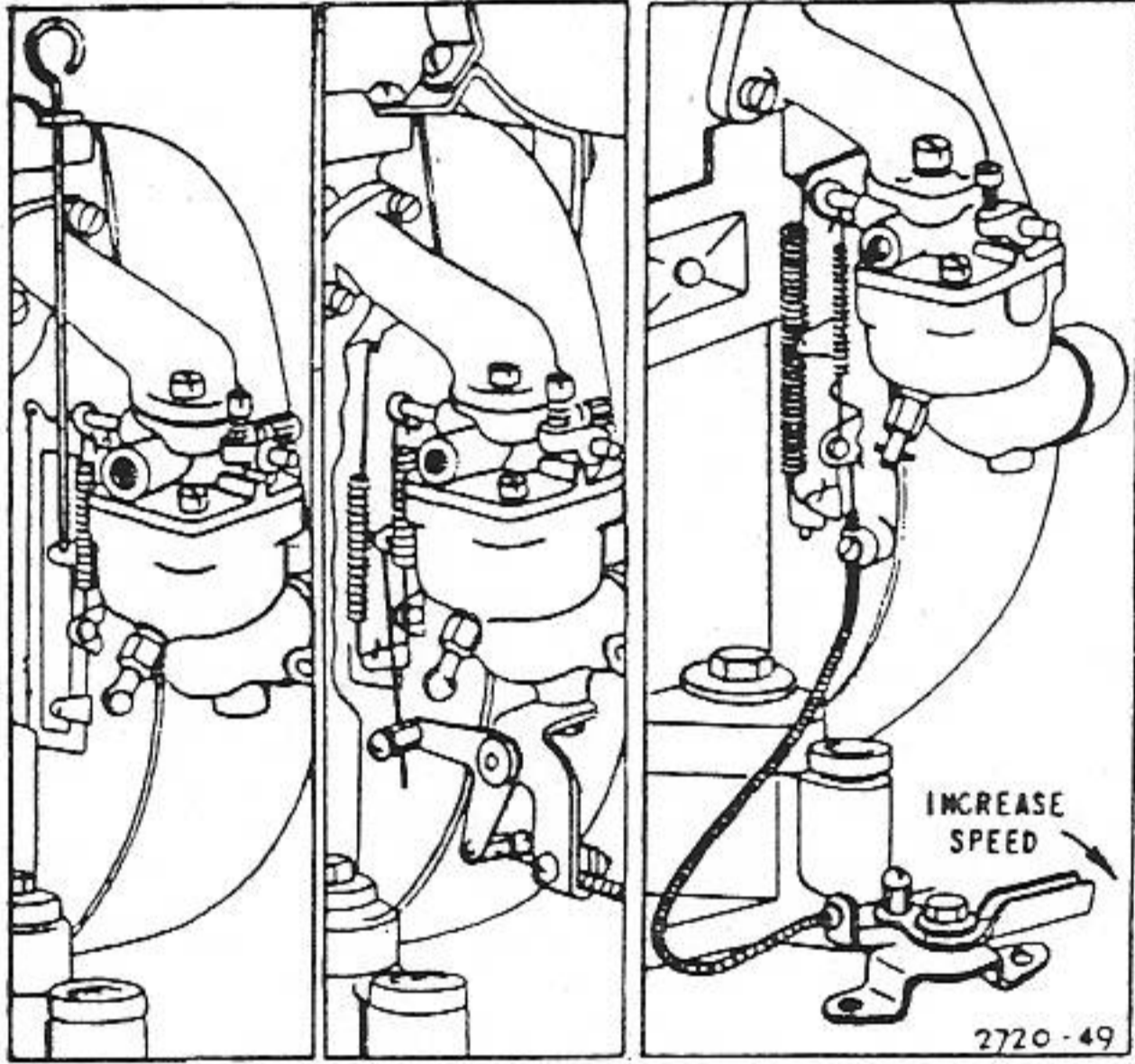


Fig. 83—Models I-N Remote Gov. Control

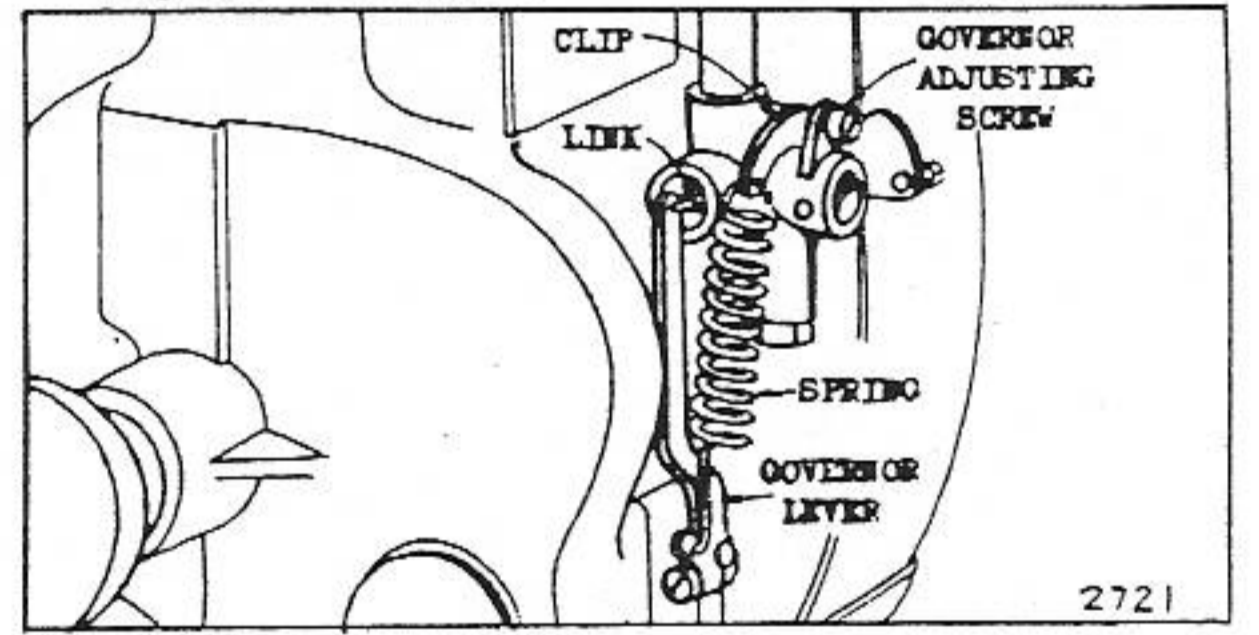


Fig. 84—Model L

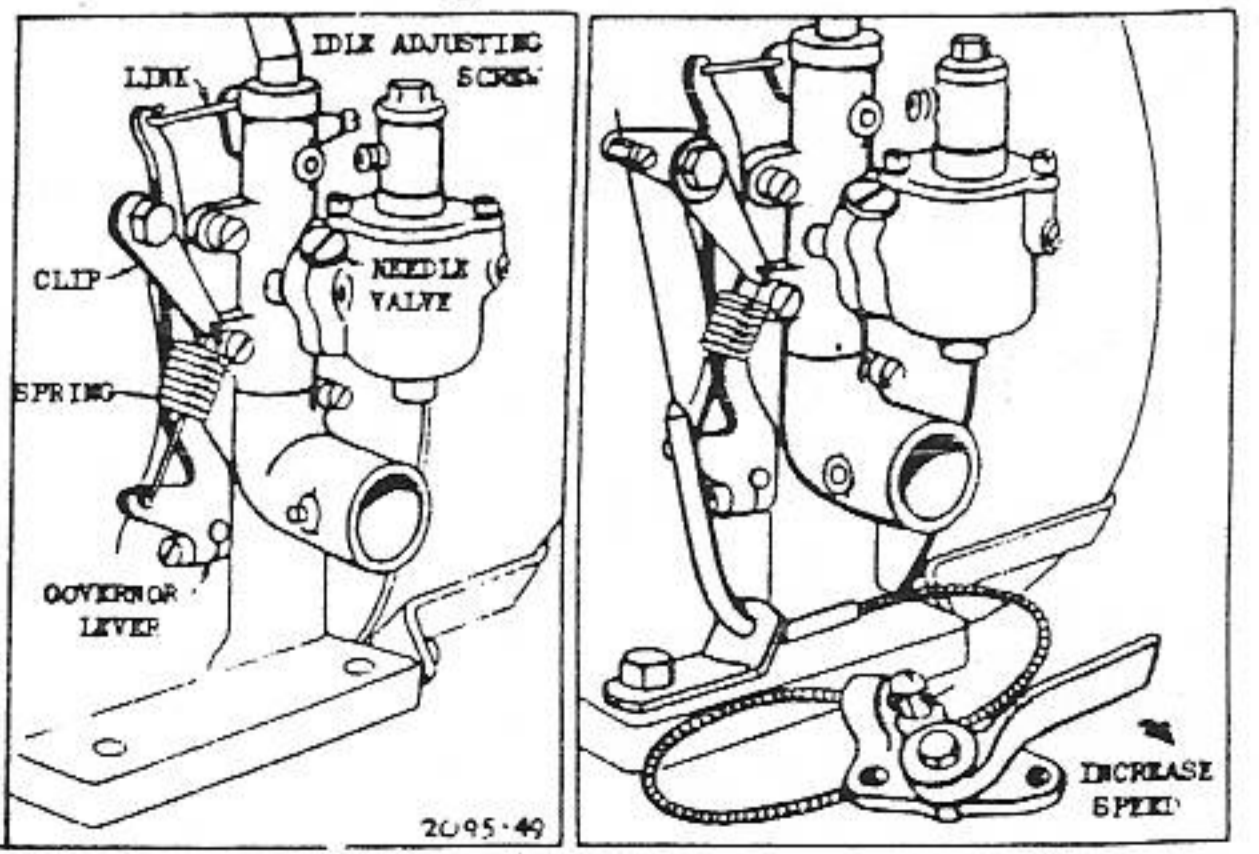


Fig. 85—Models M-T

another free manual from www.searctractormanuals.com

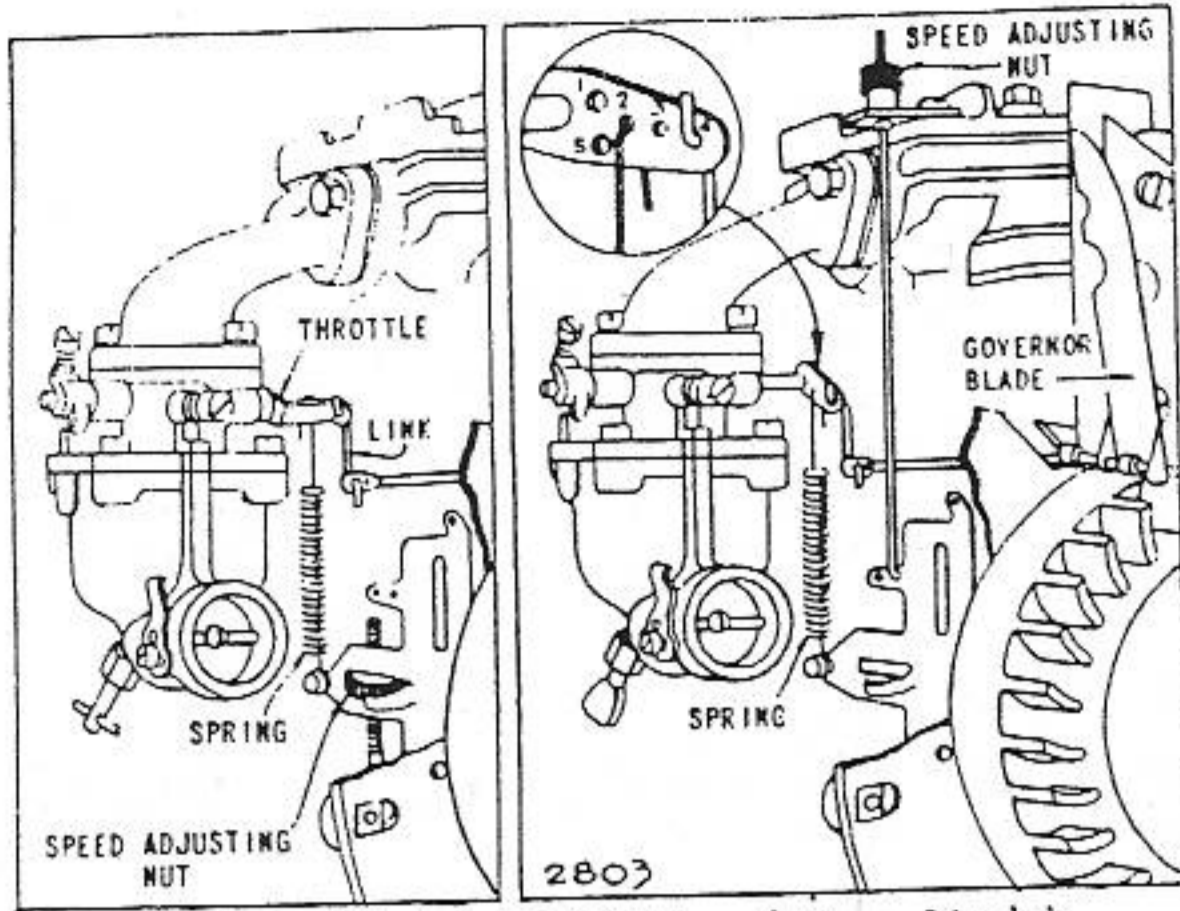


Fig. 86—Models N-8 Old and New Models

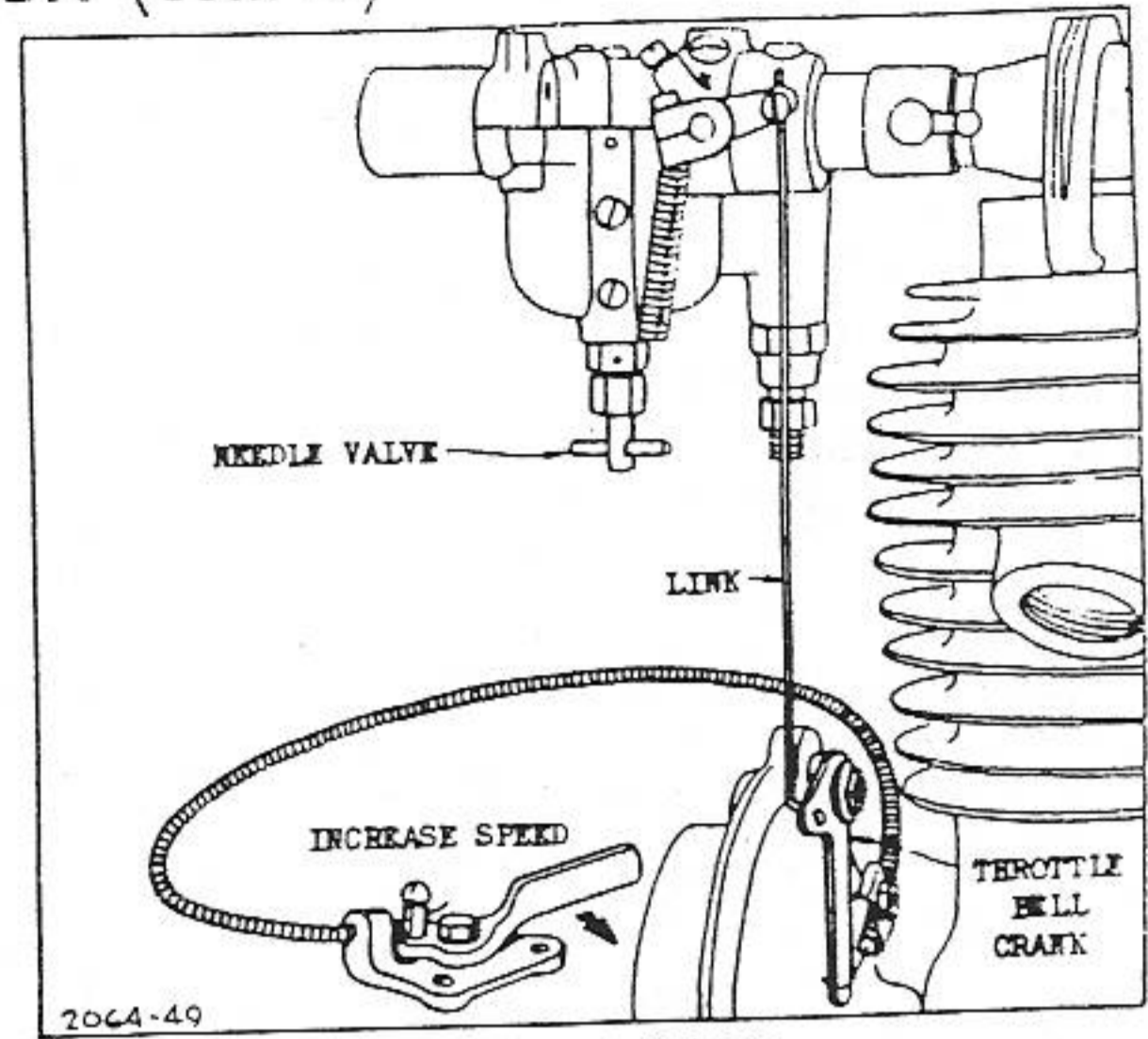


Fig. 90—Model PB

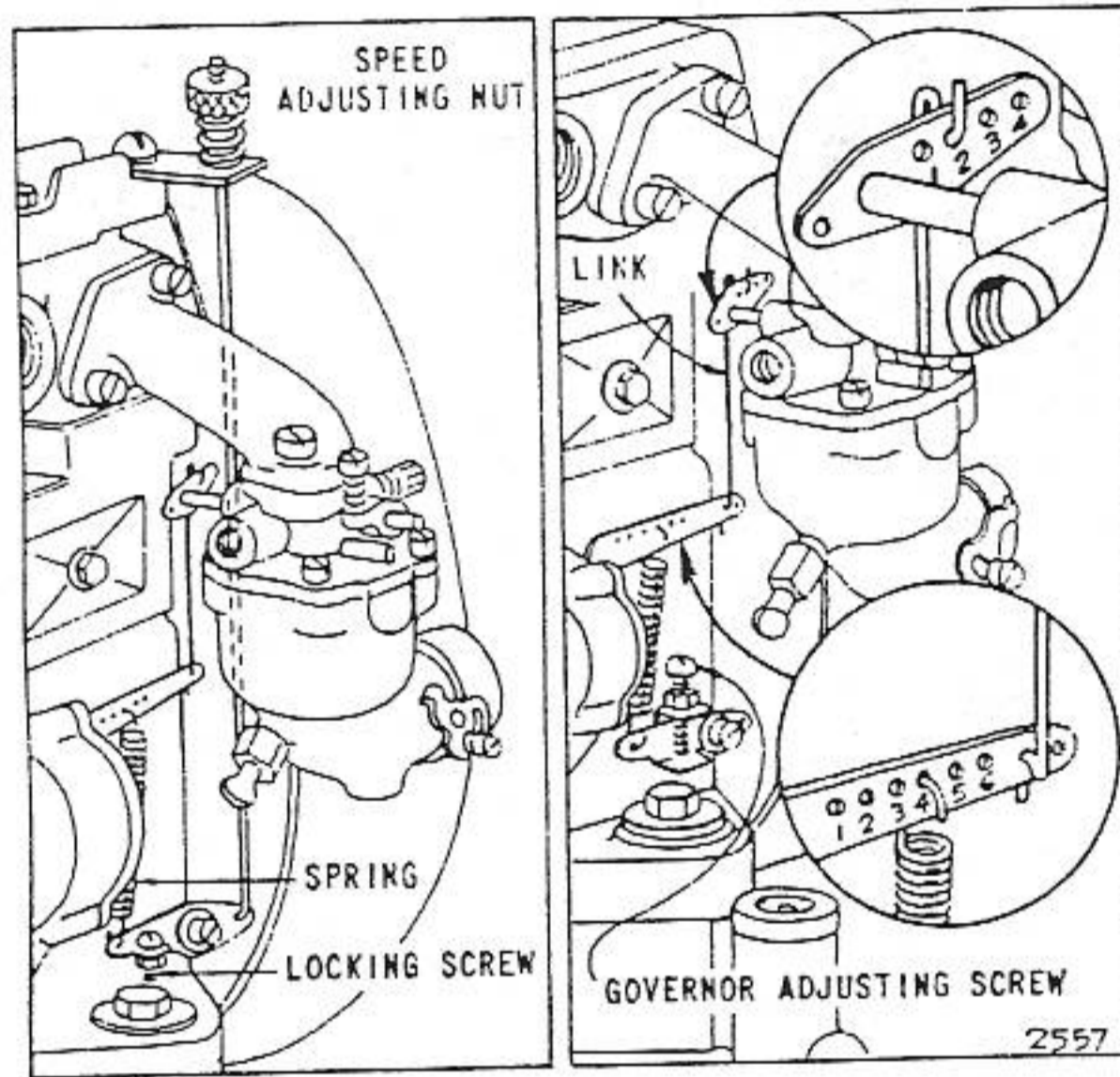


Fig. 87—Models I-N-5-8 Mech. Governor

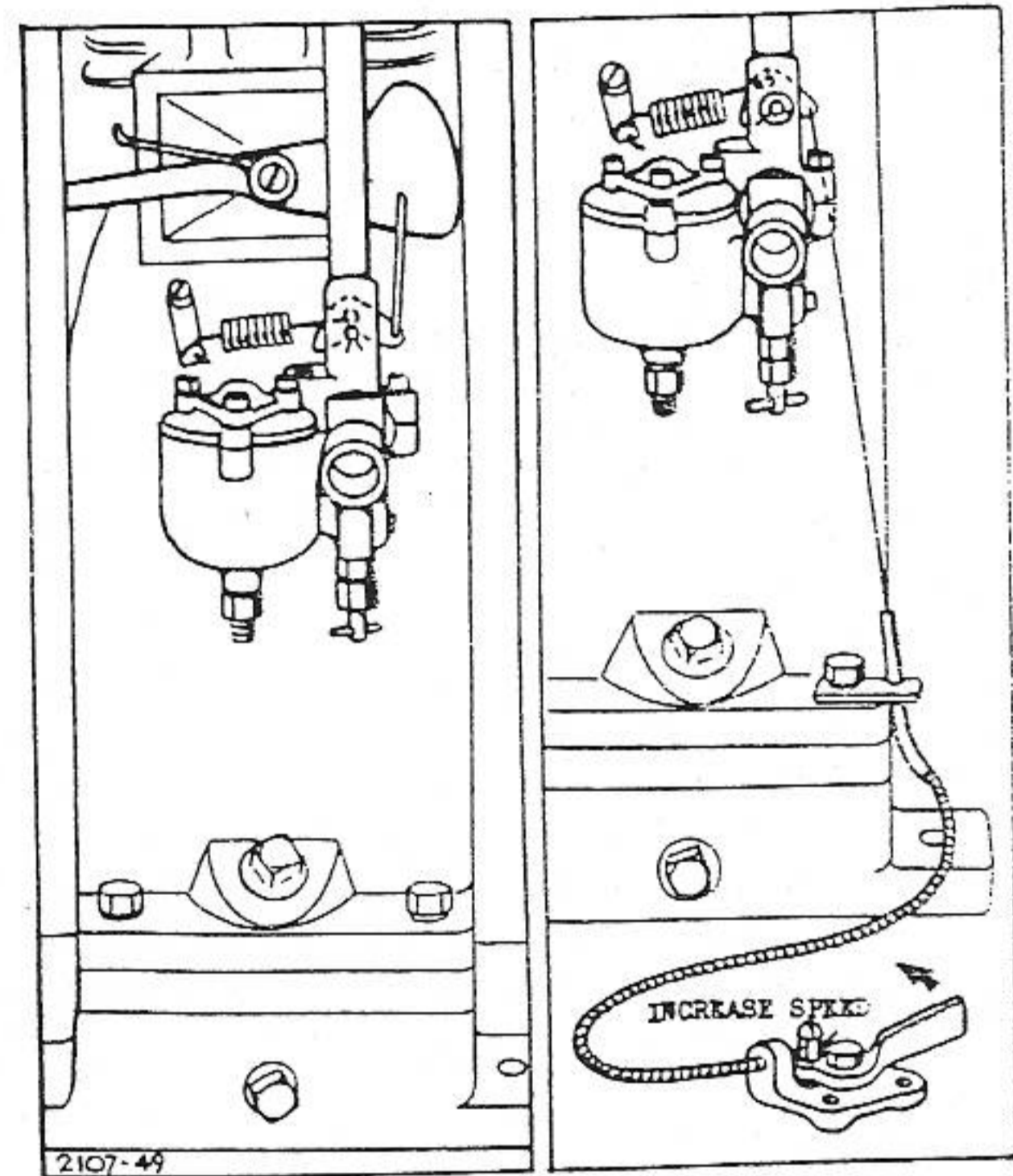


Fig. 91—Model Q

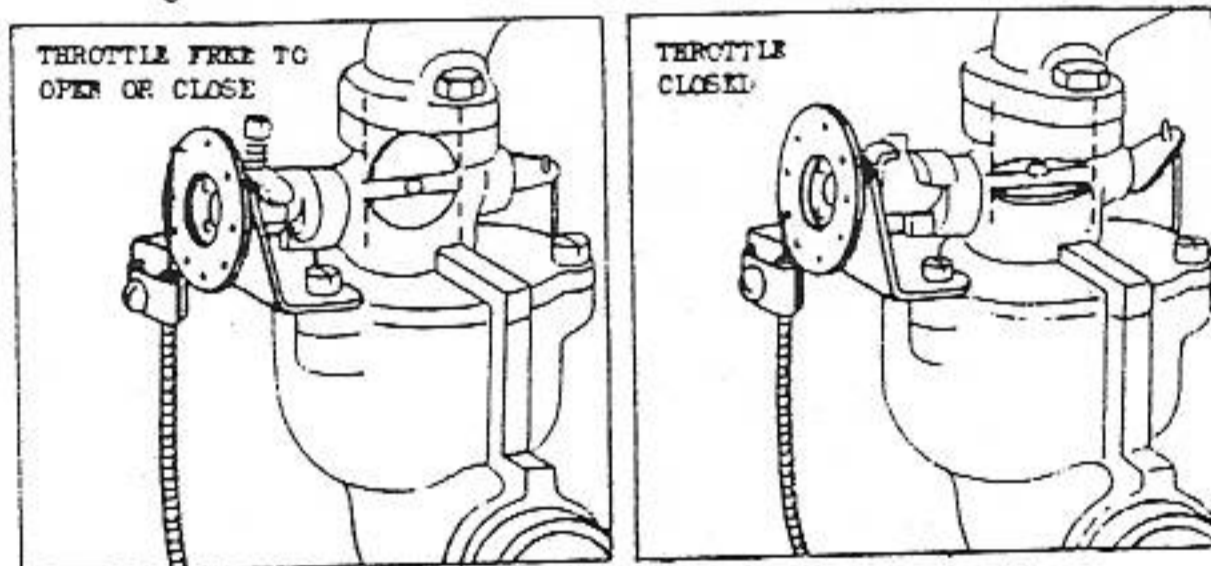


Fig. 88—Models I-N-5-6-8 Remote Throttle Control

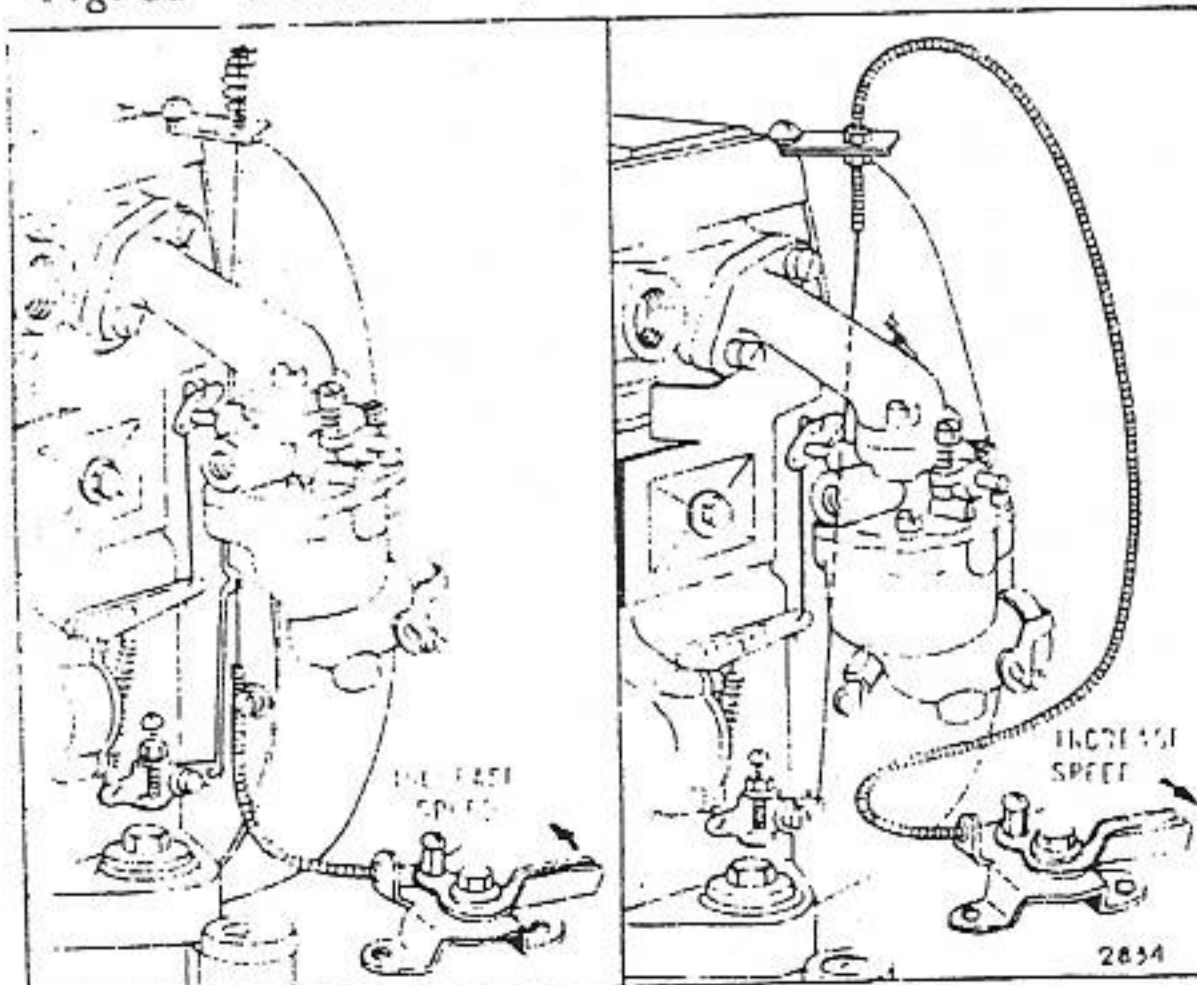


Fig. 89—Models I-N-8 Remote Mech. Gov. Control

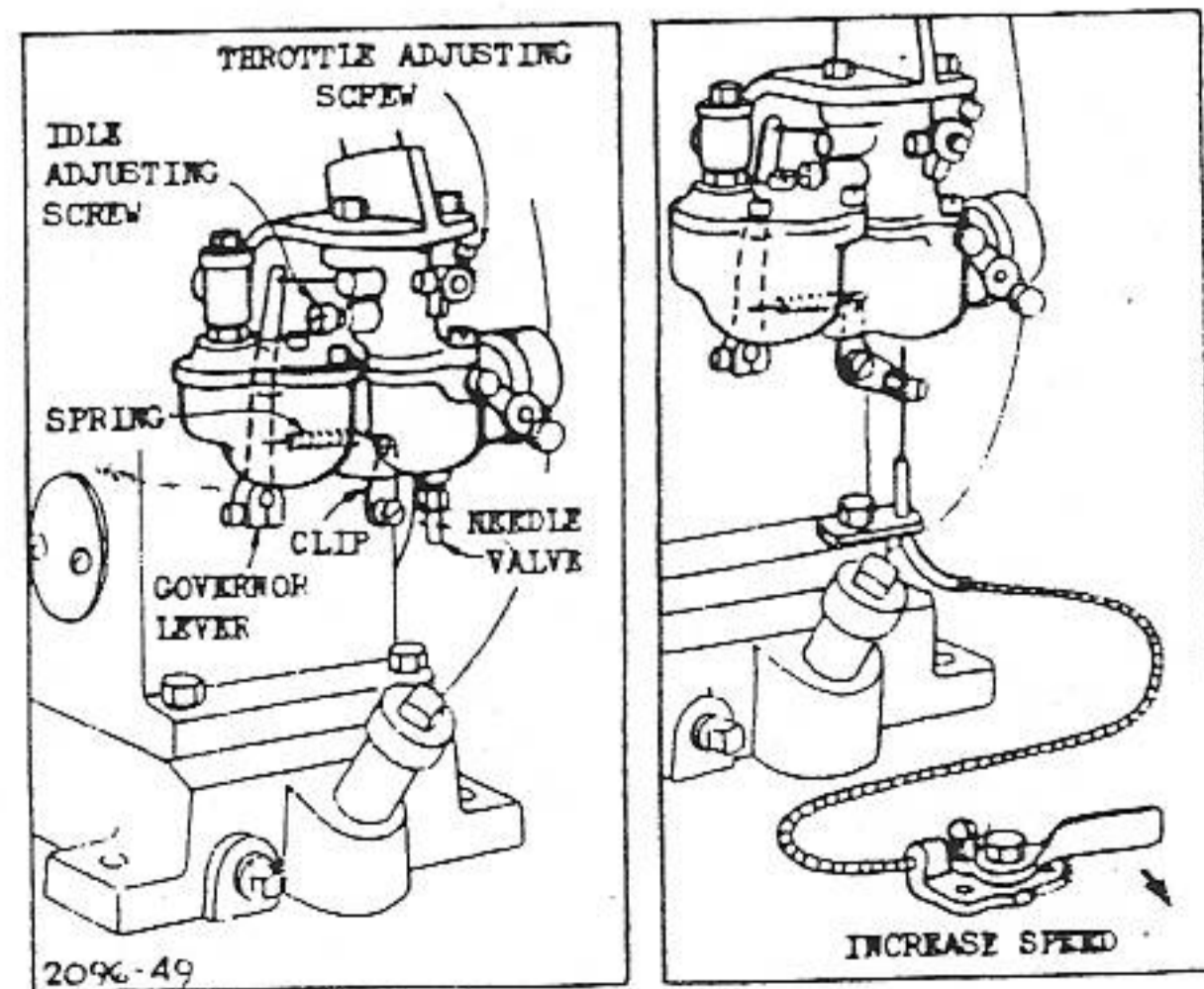


Fig. 92—Models R-W

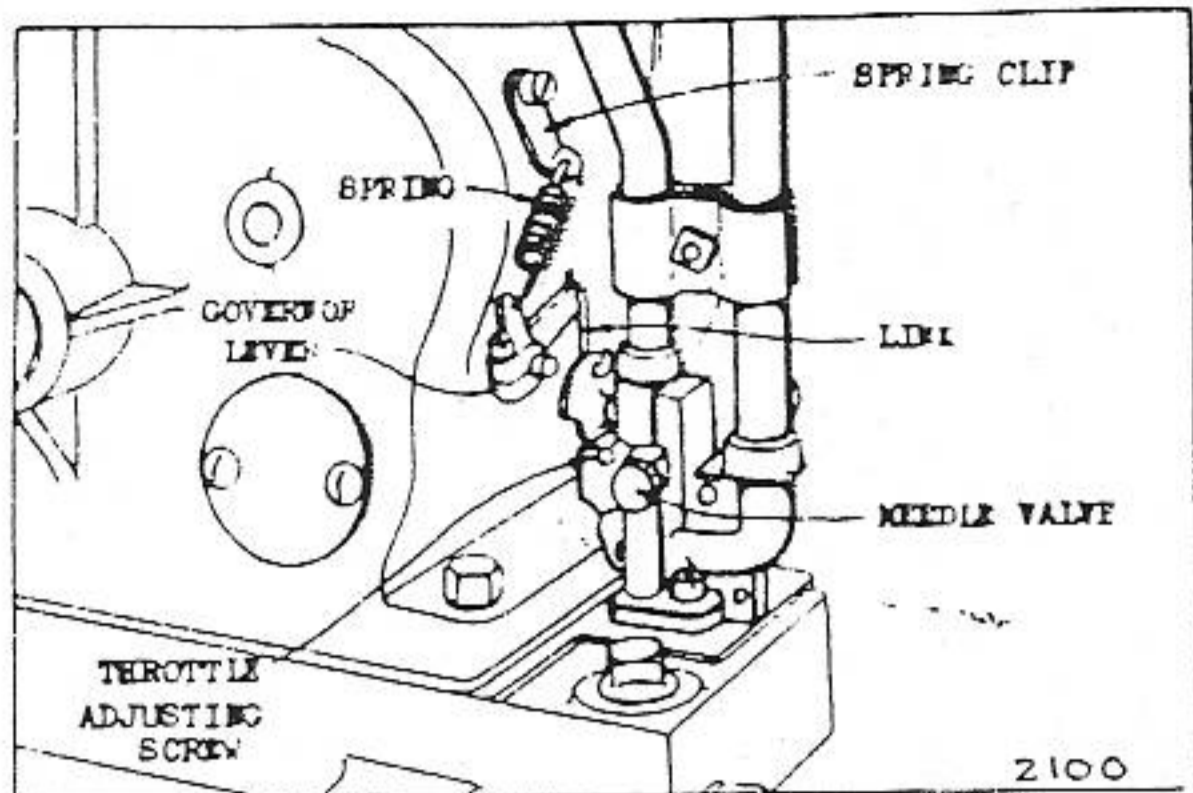


Fig. 93—Model S

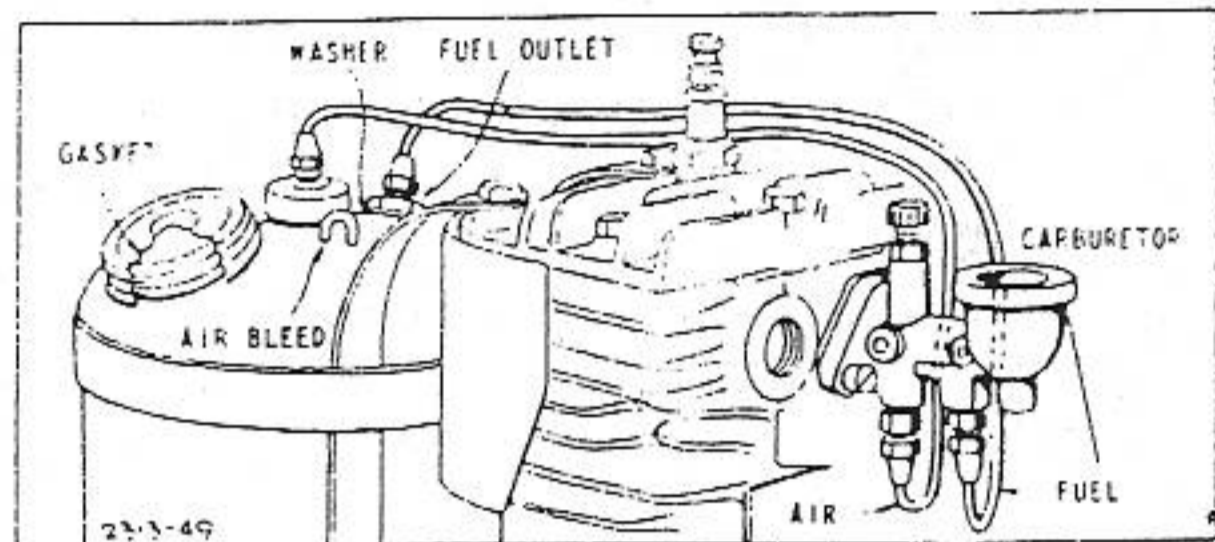


Fig. 94—Model U

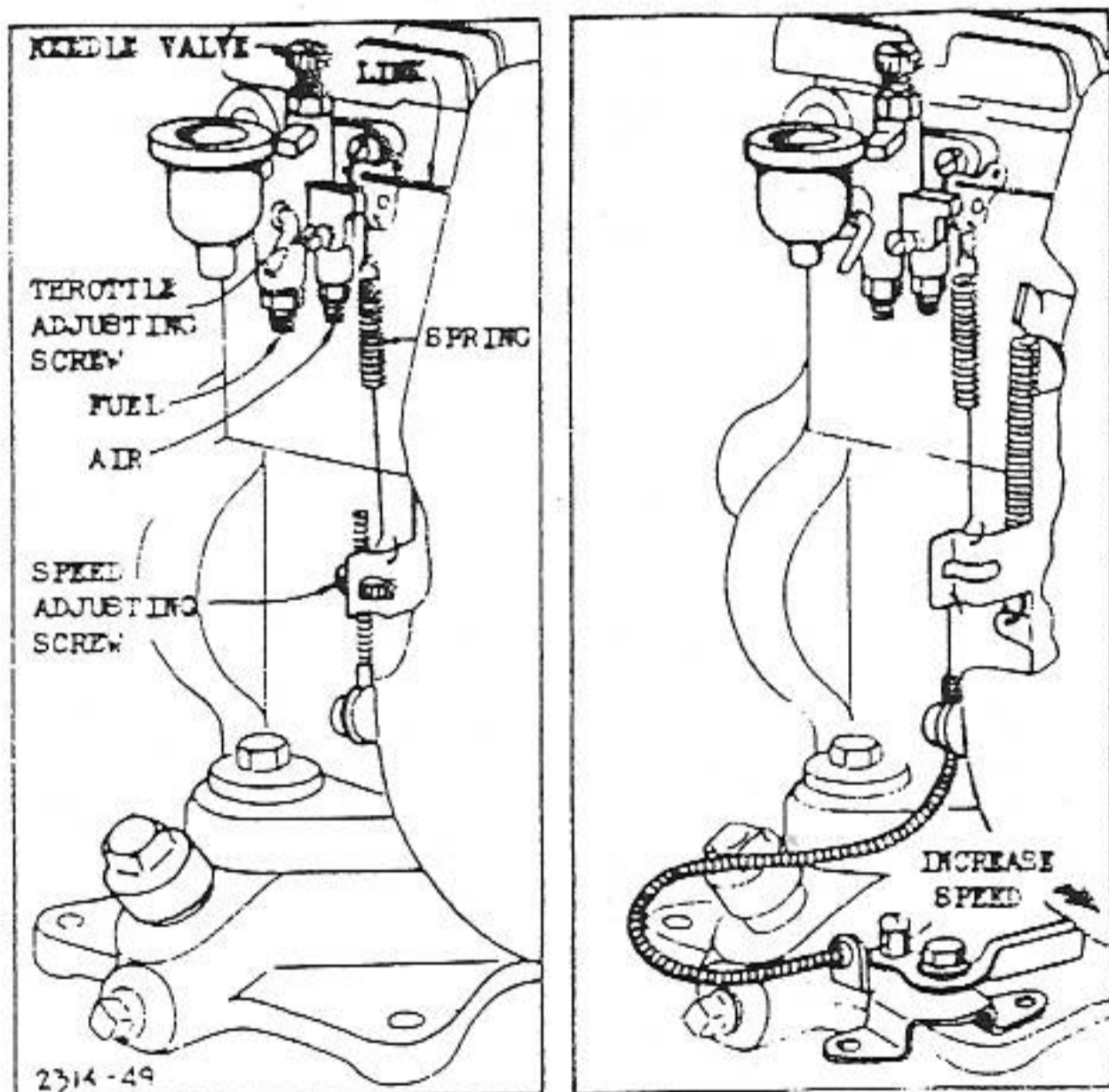


Fig. 95—Model U Remote Control

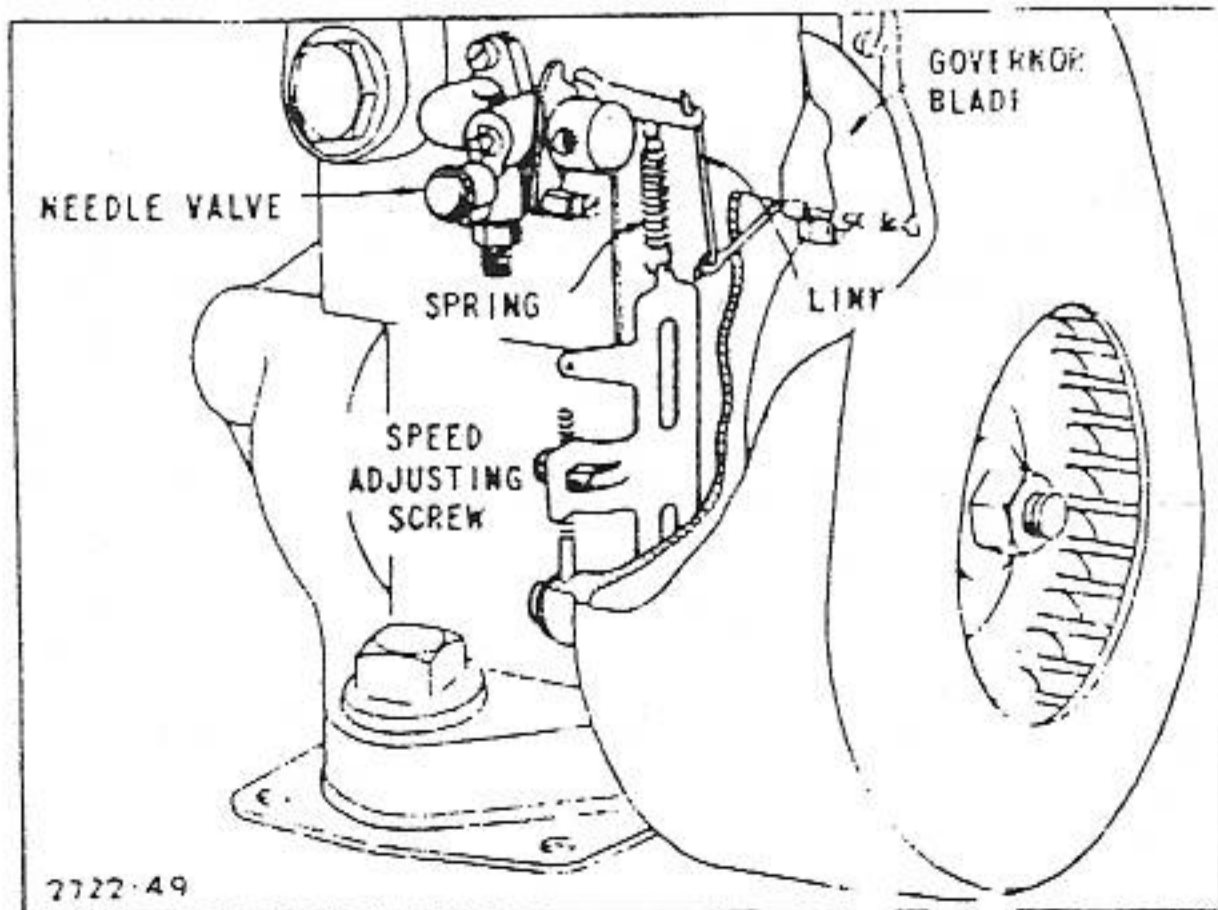


Fig. 96—Models W'BG-W'MG-W'MB W'I-W'M-W'MI

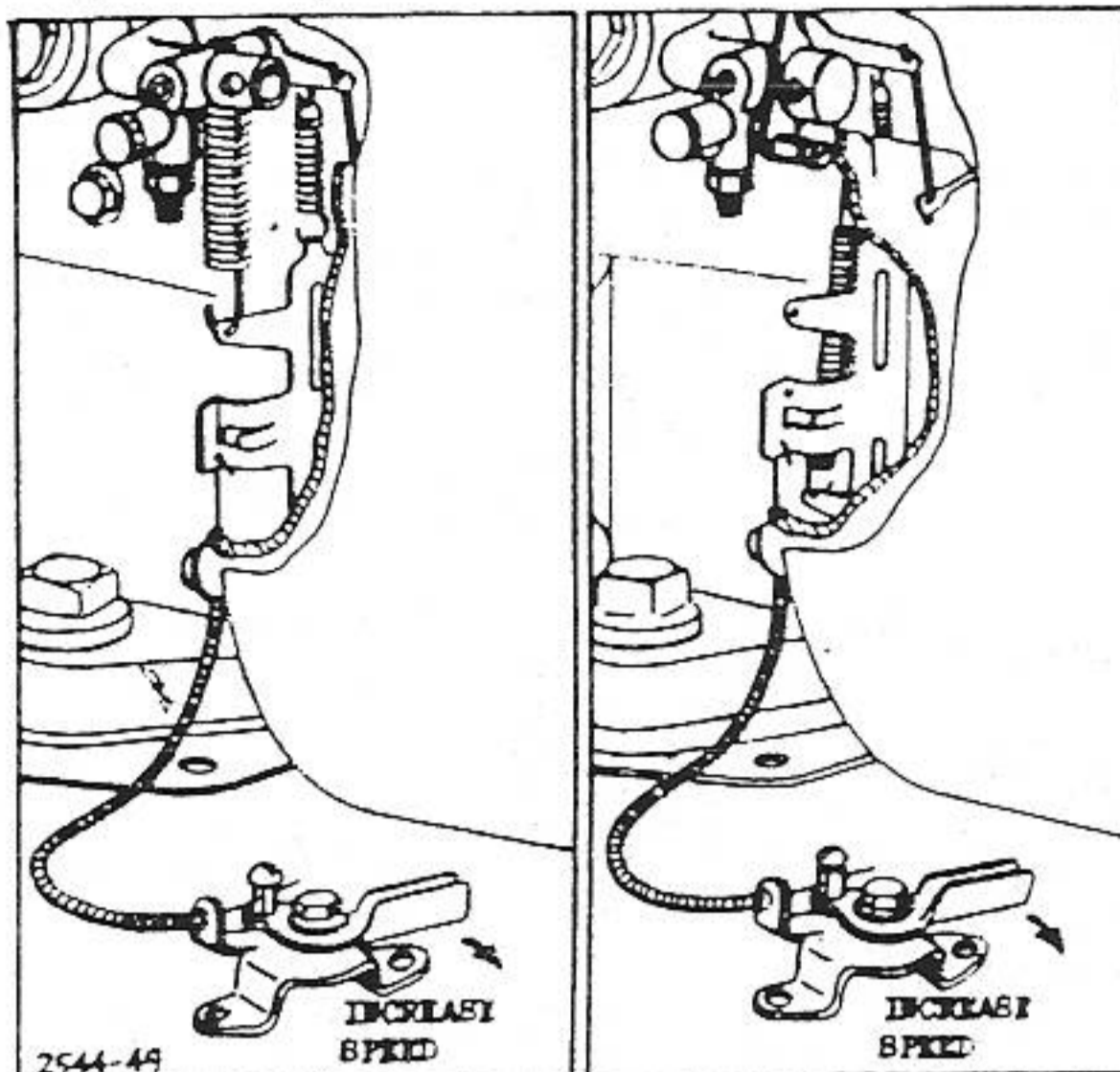


Fig. 97—Models W'BG-W'MG-W'MB-W'I-W'M-W'MI Remote Control

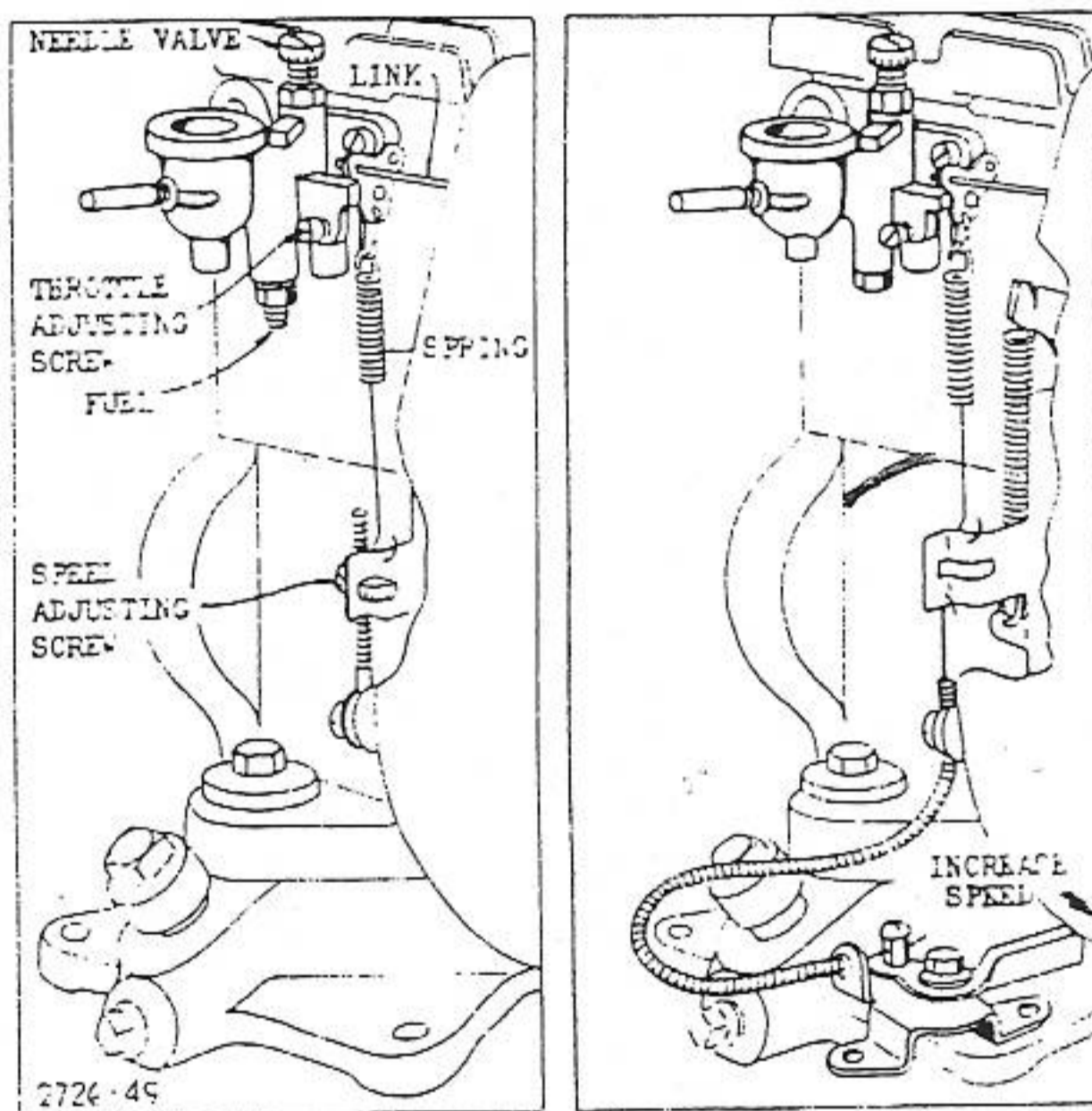


Fig. 98—Models W'I-NS

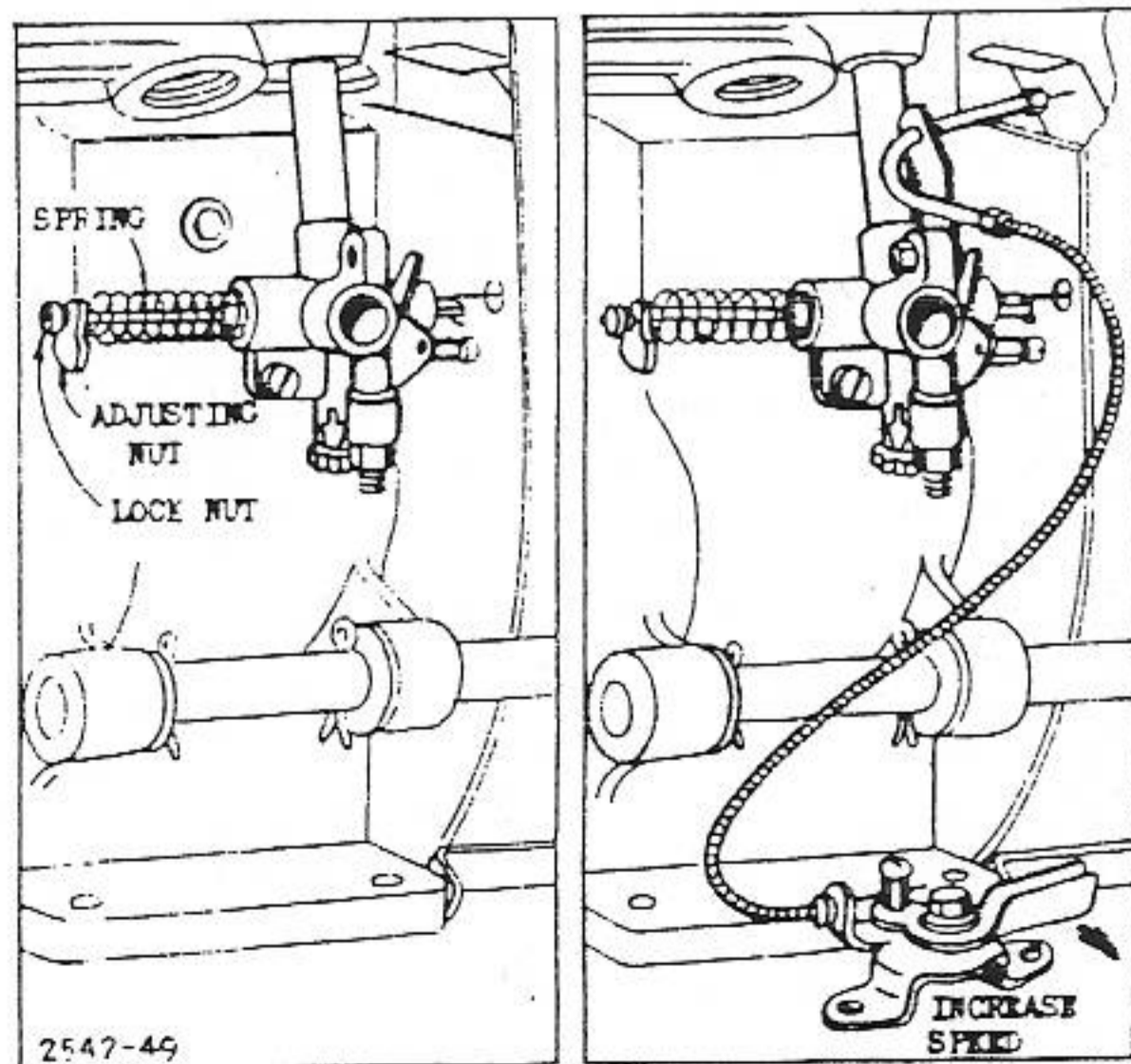


Fig. 99—Model Y

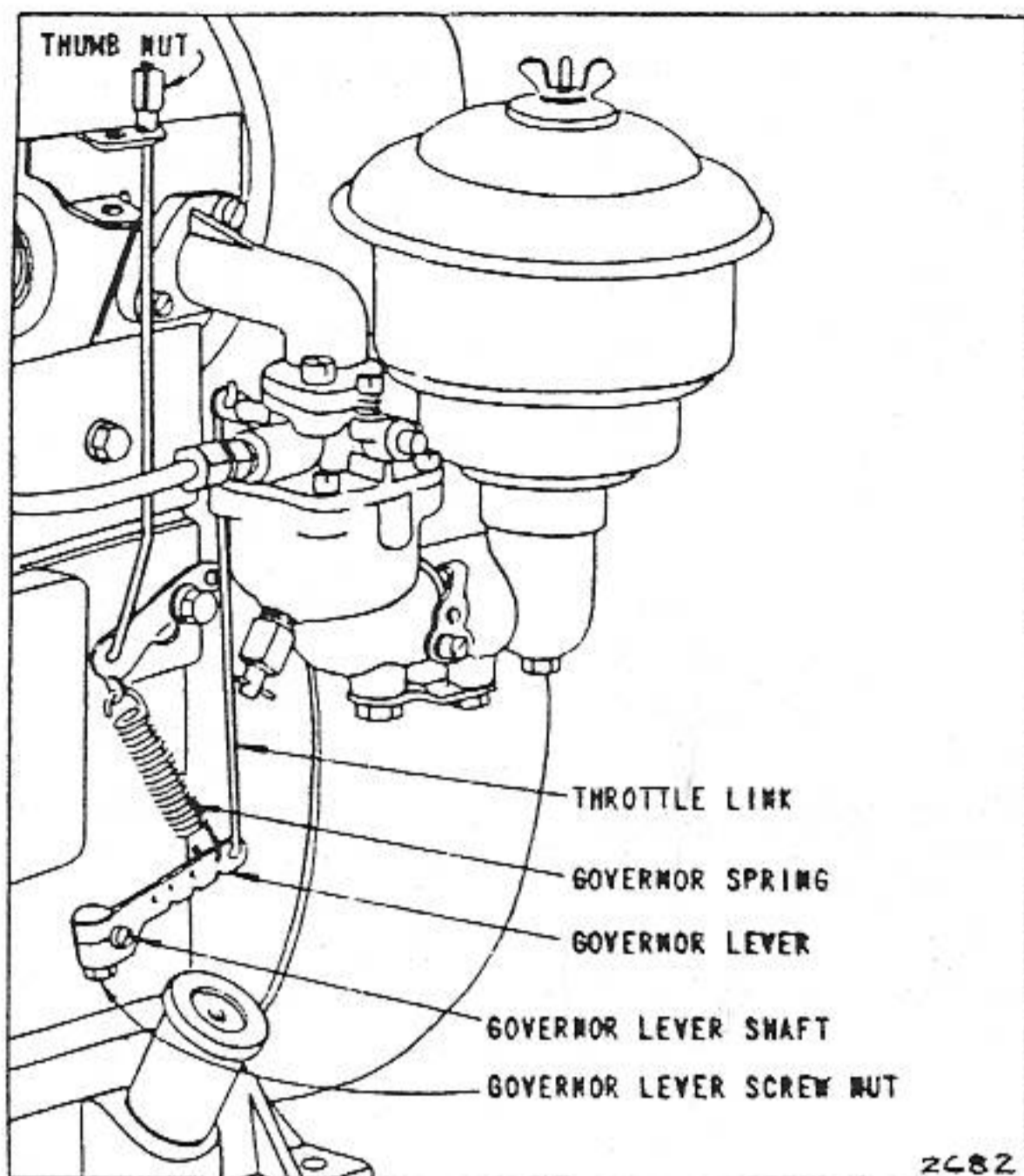


Fig. 100—Models 9-14-23

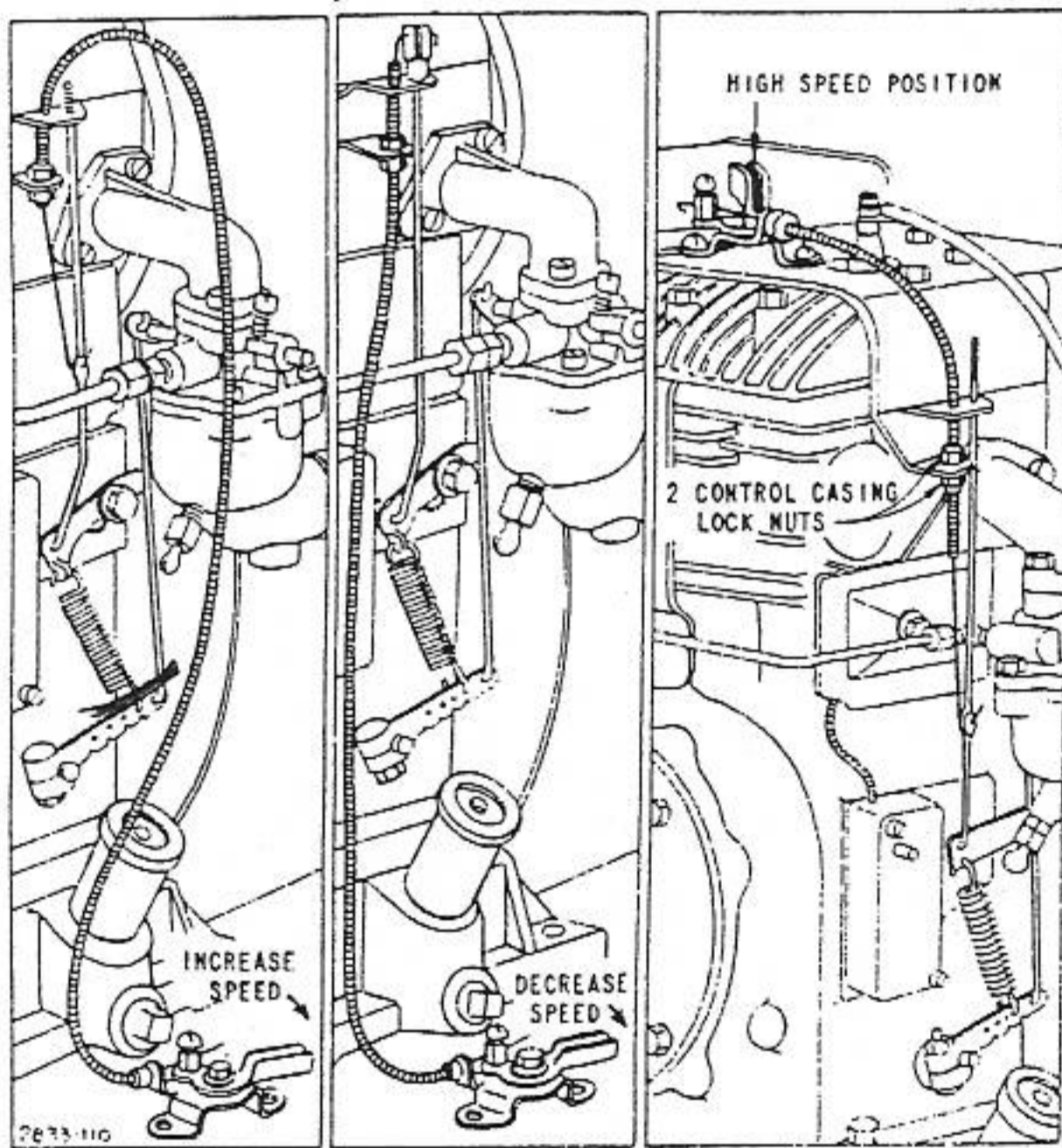


Fig. 101—Models 9-14-23 Remote Control

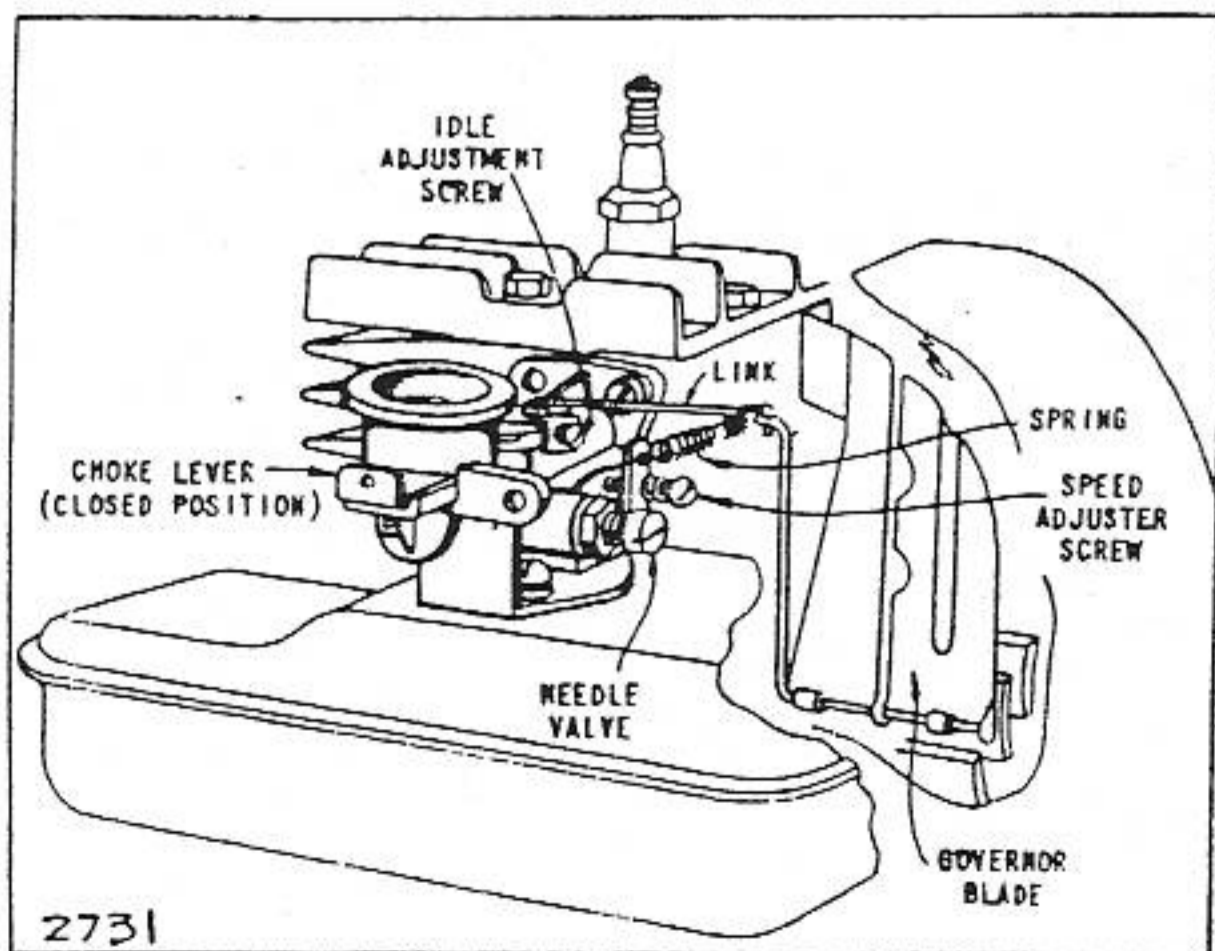


Fig. 102—Models 5S-6S

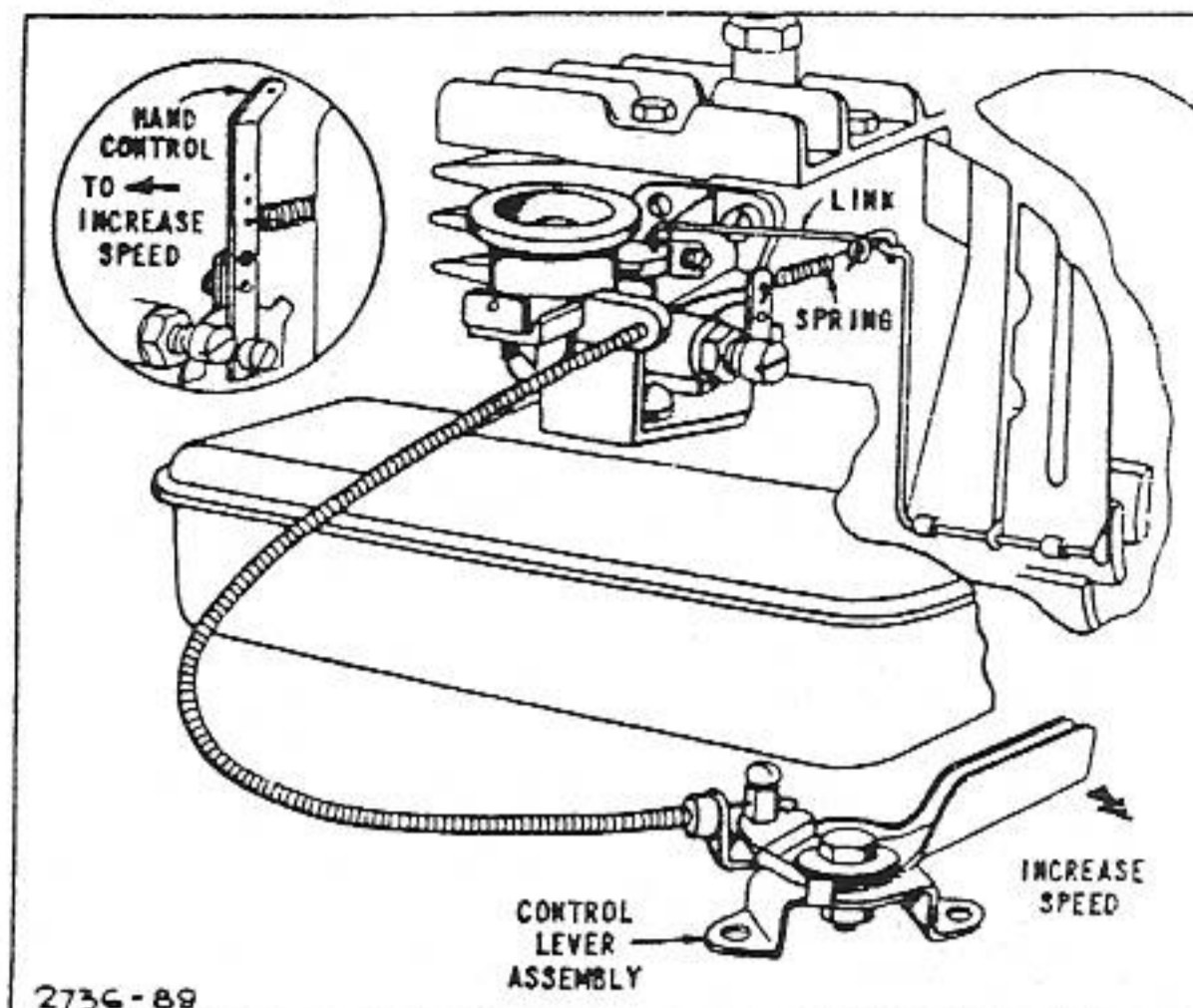


Fig. 103—Models 5S-6S Remote Control

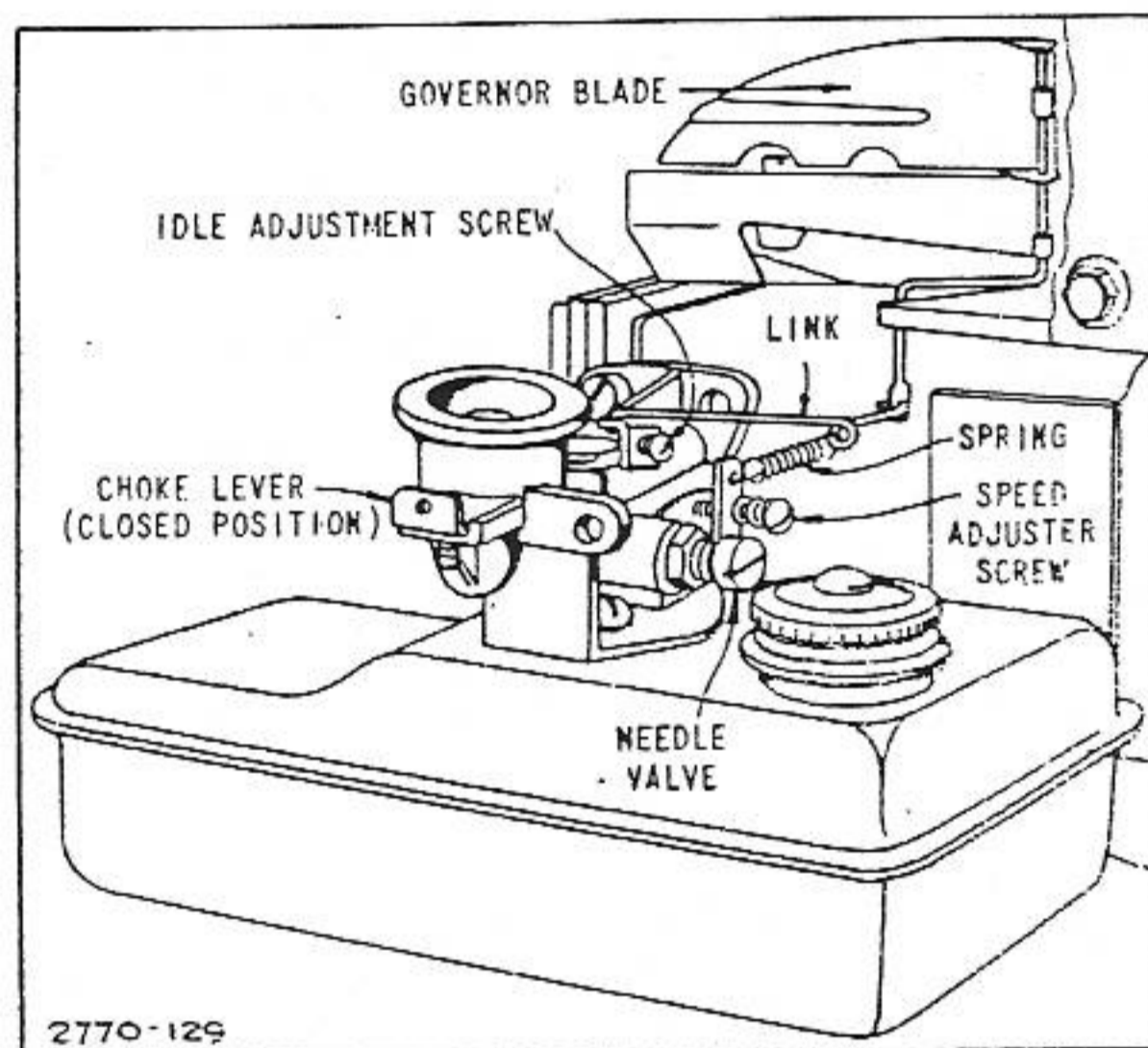


Fig. 104—Model 6HS

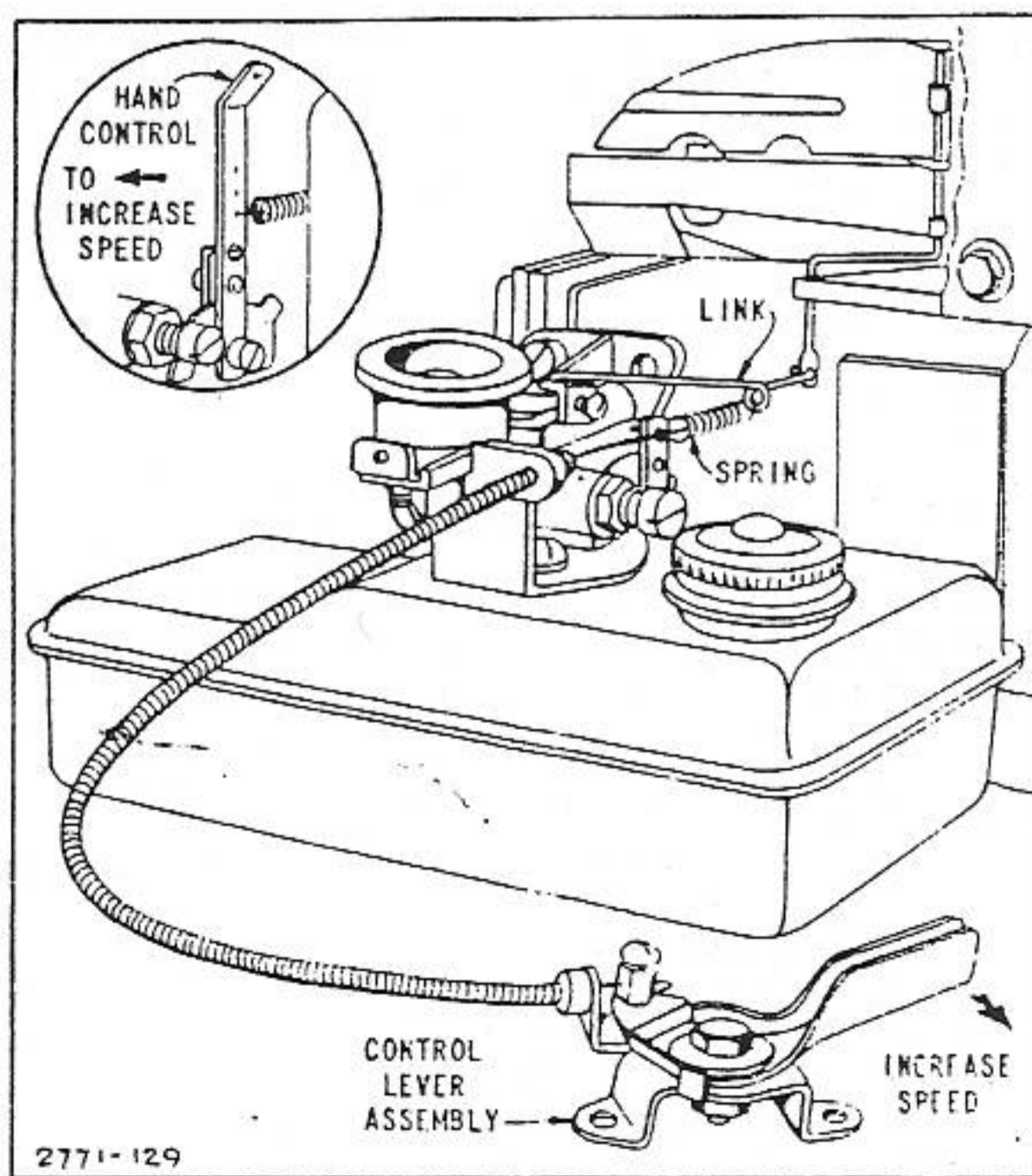


Fig. 105—Model 6HS Remote Control

CARBURETION (Cont'd.)

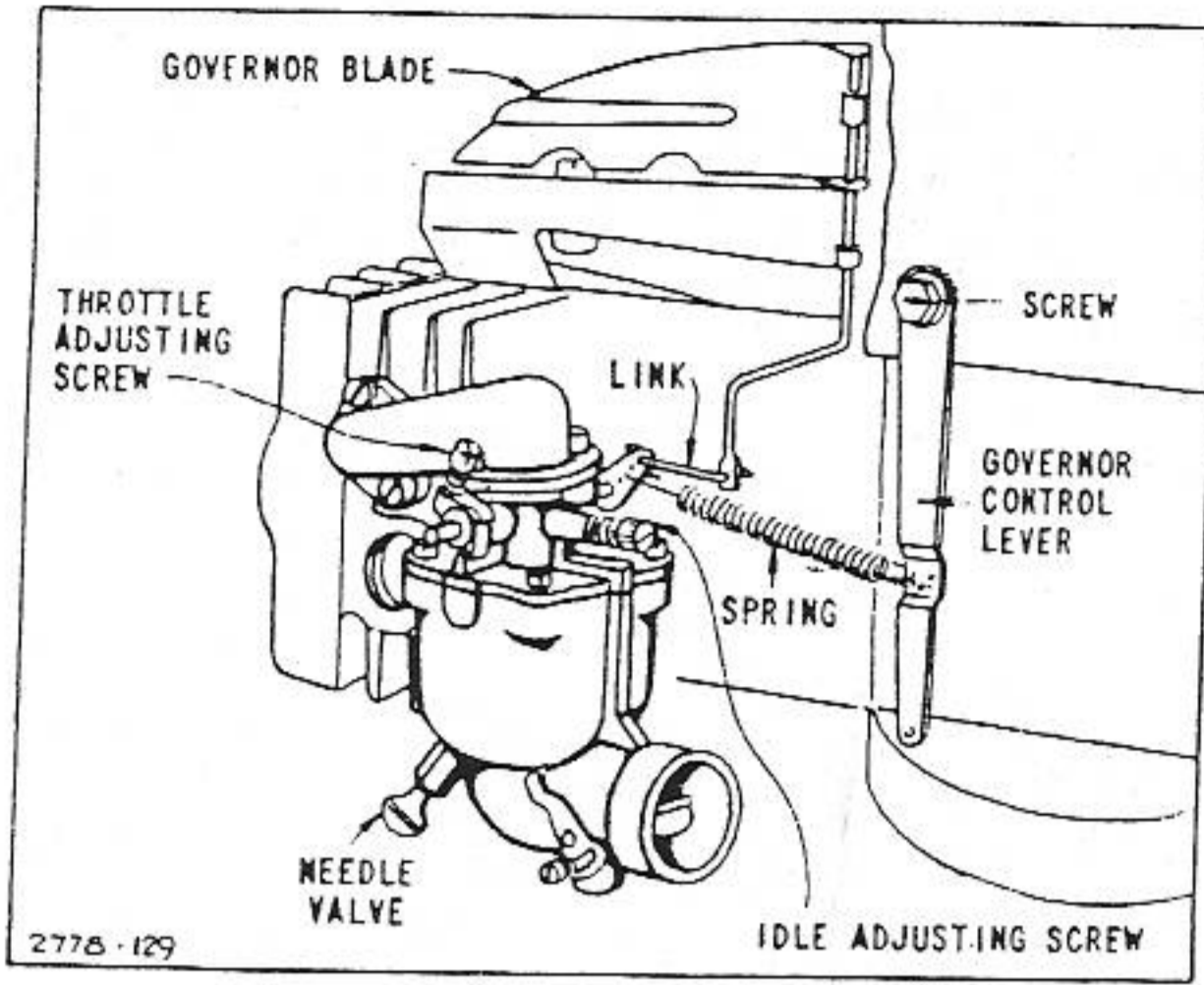


Fig. 106—Models 6H-8H

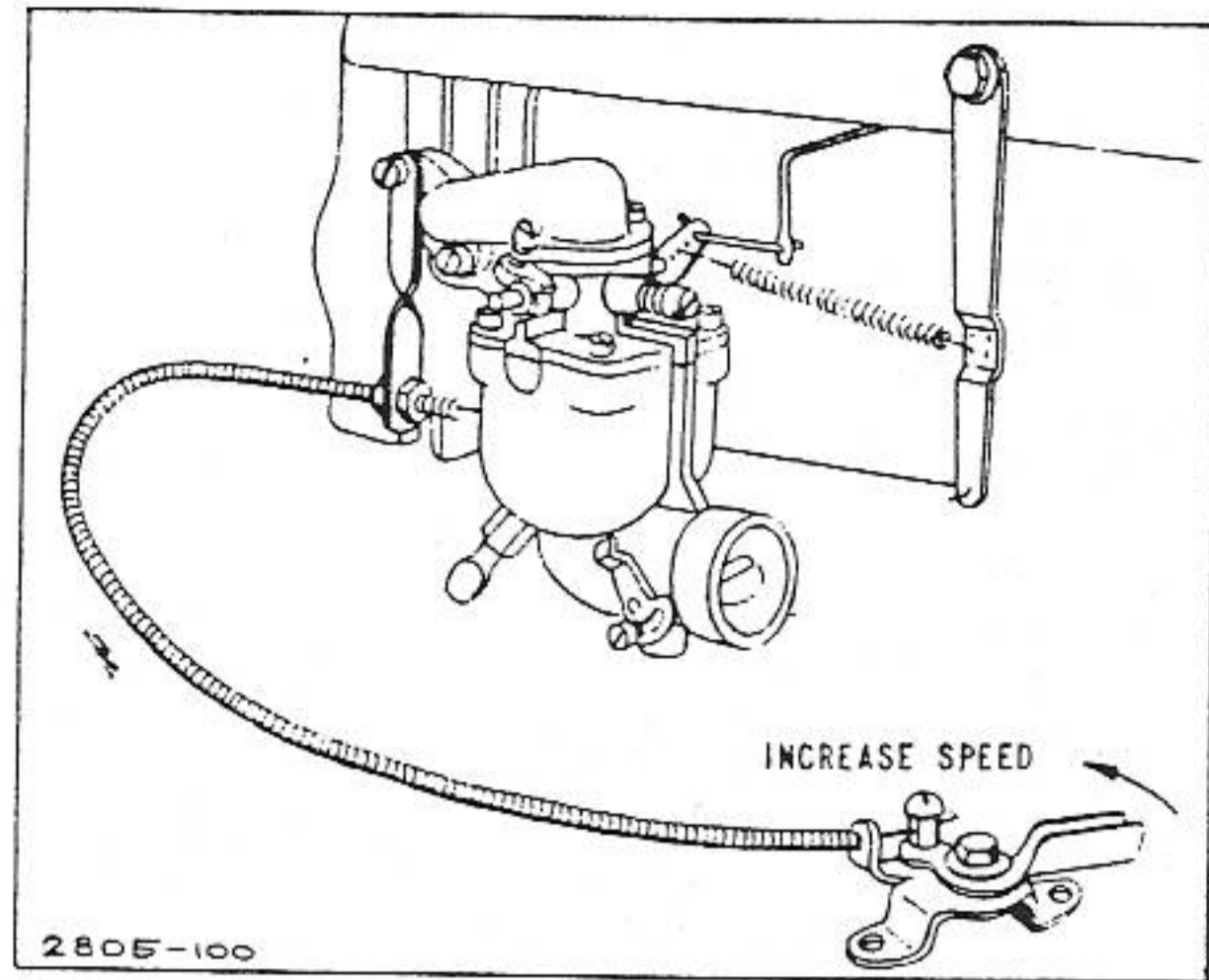


Fig. 107—Models 6H-8H Remote Governor Control

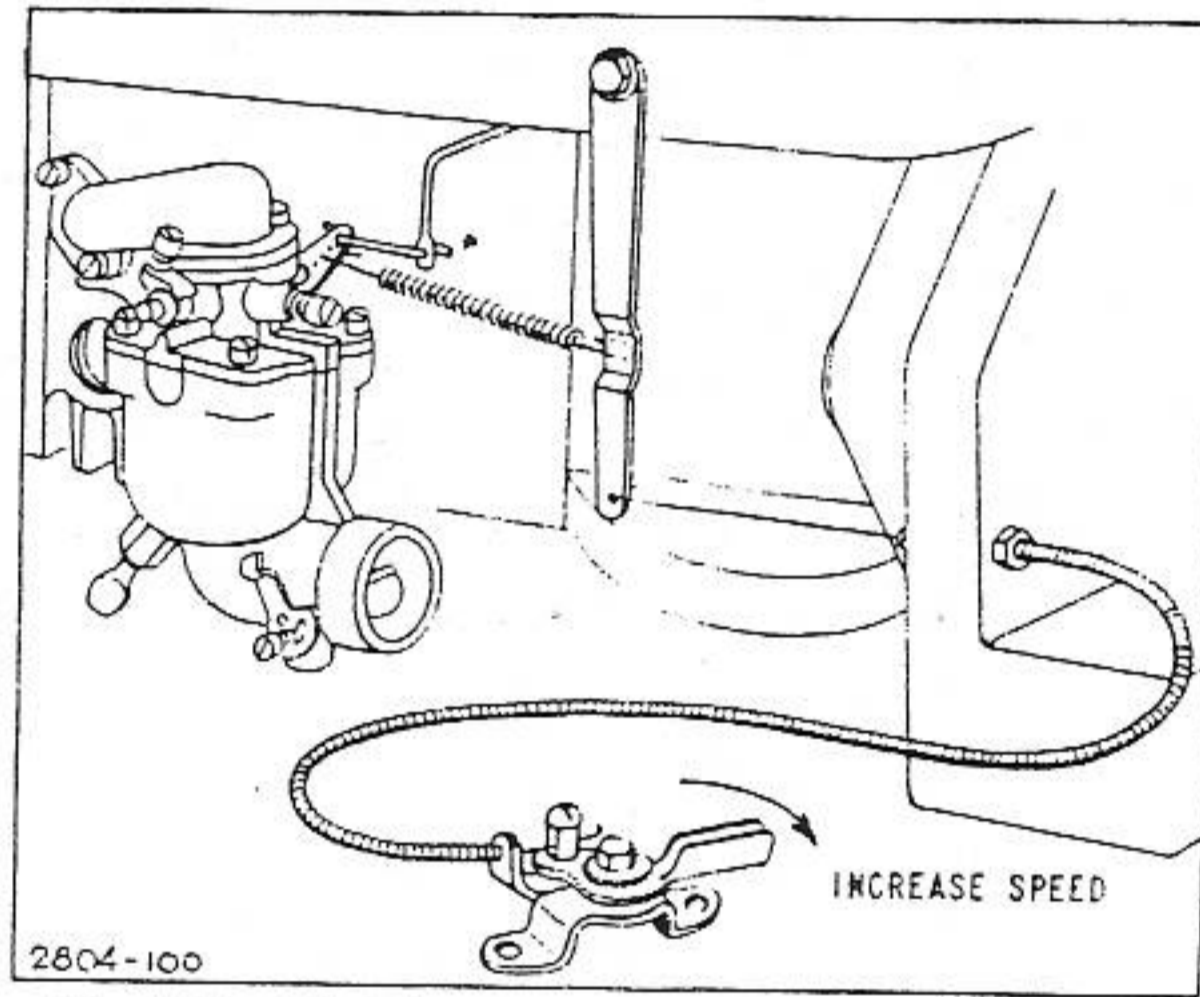


Fig. 108—Models 6H-8H Remote Governor Control

## COMPRESSION

It is easy to check the compression of Briggs & Stratton engines. Simply give the flywheel a quick spin and if it rebounds from the compression stroke, the compression is good. If the engine turns over without compression resistance, it is probable that blown gaskets, leaky valves, or worn piston and piston rings are the cause.

### To Replace Cylinder Head

When removing the cylinder head screws, be sure to note the different lengths of the screws and the position from which they are removed. If they are not replaced in the same position they may either bottom in the hole or have too little thread engagement.

Always use a new gasket if available before replacing cylinder head.

Replace cylinder head and turn each screw by hand as far as it will go. Use a socket wrench with a handle not over 6" long and tighten all screws evenly with a 1/4 turn in rotation 1 to 6 as shown in Fig. 109. Do not tighten one screw down completely before the others as this may cause the cylinder head to warp or damage the gasket. Run the engine 2 to 5 minutes. Then tighten all screws snugly (which will normally be about 1/4 turn) in the same rotation.

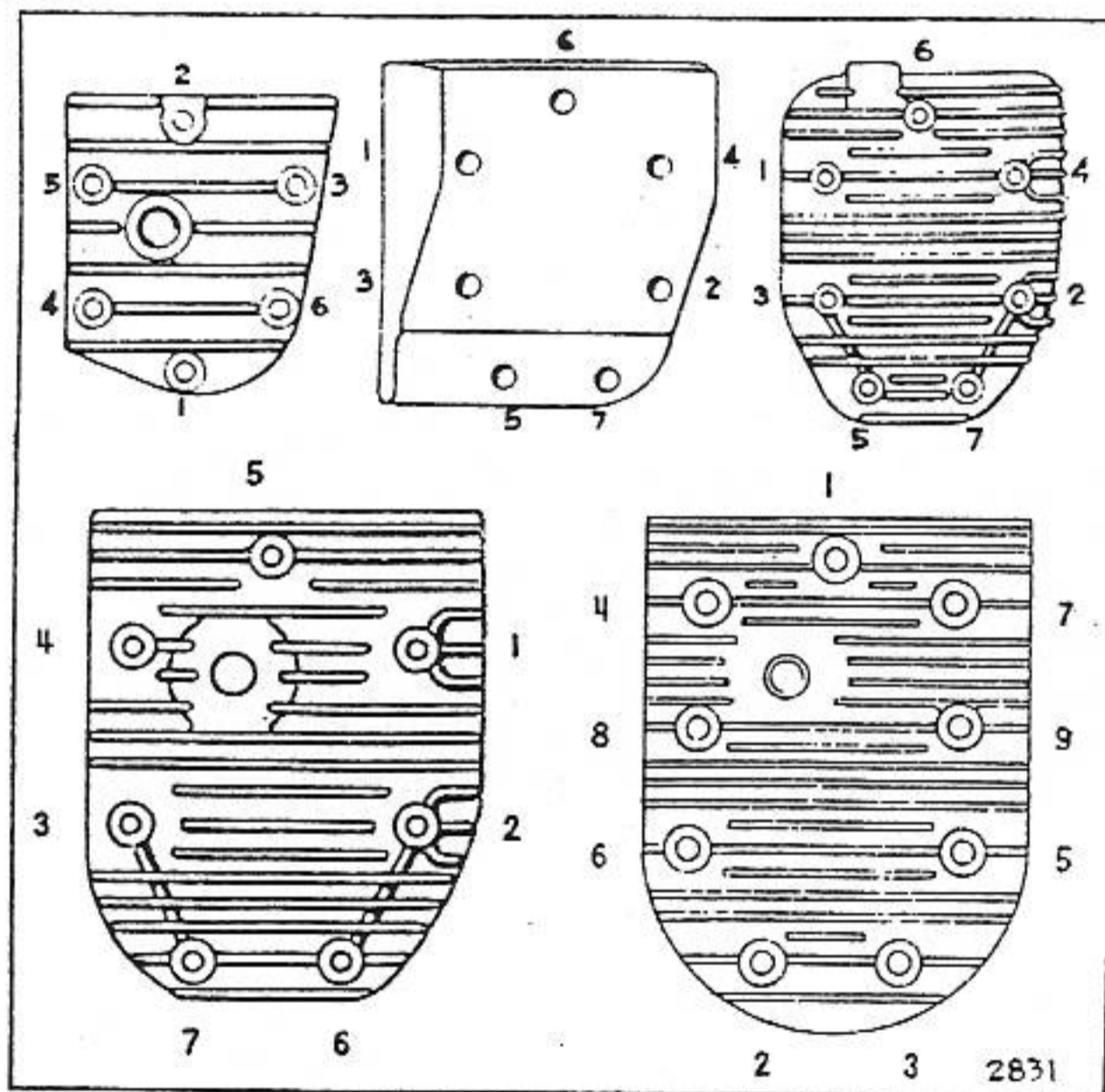


FIG. 109—CYLINDER HEADS

### To Check Tappet Clearance

Turn flywheel until valve opens to the highest point. Then turn flywheel one complete revolution. This will turn the cam gear a half revolution and will place lobes in a 180° position from the cam followers. Repeat for each valve. The valve clearance should be as shown in Table No. 6. On later models, the valve clearance is stamped on the name plates on the engines. Always check clearances when engine is cold.

TABLE 6 - VALVE TAPPET CLEARANCES

| ENGINE MODEL             | VALVE TAPPET CLEARANCE |      |         |      |
|--------------------------|------------------------|------|---------|------|
|                          | INTAKE                 |      | EXHAUST |      |
|                          | MAX.                   | MIN. | MAX.    | MIN. |
| A (5 Digit)              | .007                   | .005 | .009    | .007 |
| A (6 Digit)              | .009                   | .007 | .011    | .009 |
| A With TPA Ex. Valves    | .009                   | .007 | .016    | .014 |
| B (5 Digit)              | .007                   | .005 | .009    | .007 |
| B (6 Digit)              | .009                   | .007 | .011    | .009 |
| B With TPA Ex. Valves    | .009                   | .007 | .016    | .014 |
| FH                       | 1/16                   | 1/32 | .013    | .011 |
| FI                       | .007                   | .005 | .007    | .005 |
| FJ                       | .011                   | .009 | .021    | .019 |
| H                        | .011                   | .009 | .021    | .019 |
| I-IBP                    | .009                   | .007 | .016    | .014 |
| K                        | .007                   | .005 | .015    | .013 |
| L                        | .011                   | .009 | .021    | .019 |
| M                        | .007                   | .005 | .009    | .007 |
| M-NS                     | .009                   | .007 | .016    | .014 |
| PB                       | 3/32                   | 1/16 | .021    | .019 |
| Q-R-S-T-W                | .007                   | .005 | .009    | .007 |
| U-WBG-WI-WM-WMB-WMG-WMI  | .009                   | .007 | .016    | .014 |
| Y                        | .011                   | .009 | .021    | .019 |
| Z                        | .009                   | .007 | .016    | .014 |
| ZZ                       | .021                   | .019 | .019    | .017 |
| ZZ With TPA Ex. Valves   | .021                   | .019 | .023    | .021 |
| 5-6-8                    | .009                   | .007 | .016    | .014 |
| 9-14                     | .009                   | .007 | .016    | .014 |
| 9-14 With TPA Ex. Valves | .009                   | .007 | .019    | .017 |
| 23                       | .009                   | .007 | .019    | .017 |
| 23 With TPA Ex. Valves   | .009                   | .007 | .023    | .021 |

### To Remove and Replace Valve and Valve Springs

The valve springs and retainers are held in place on the larger engines with tapered collars and on smaller engines with a pin through the valve stem.

#### Model 8 and 2" Bore Engines

Use a screw driver and open end wrench to pry up valve spring and a needle-nose pliers to remove and insert the pin when replacing the valve and springs. Fig. 110, Ill. 1 to 6.

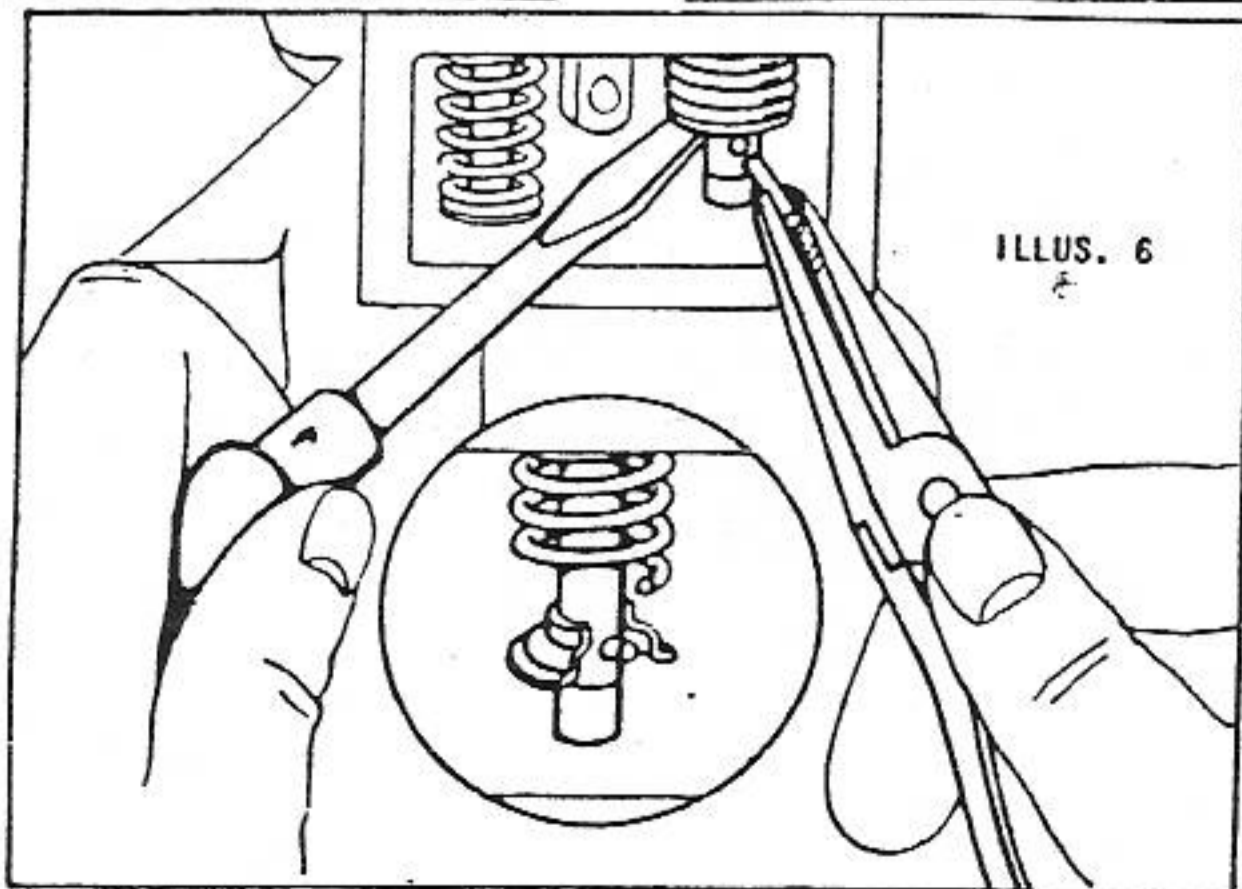
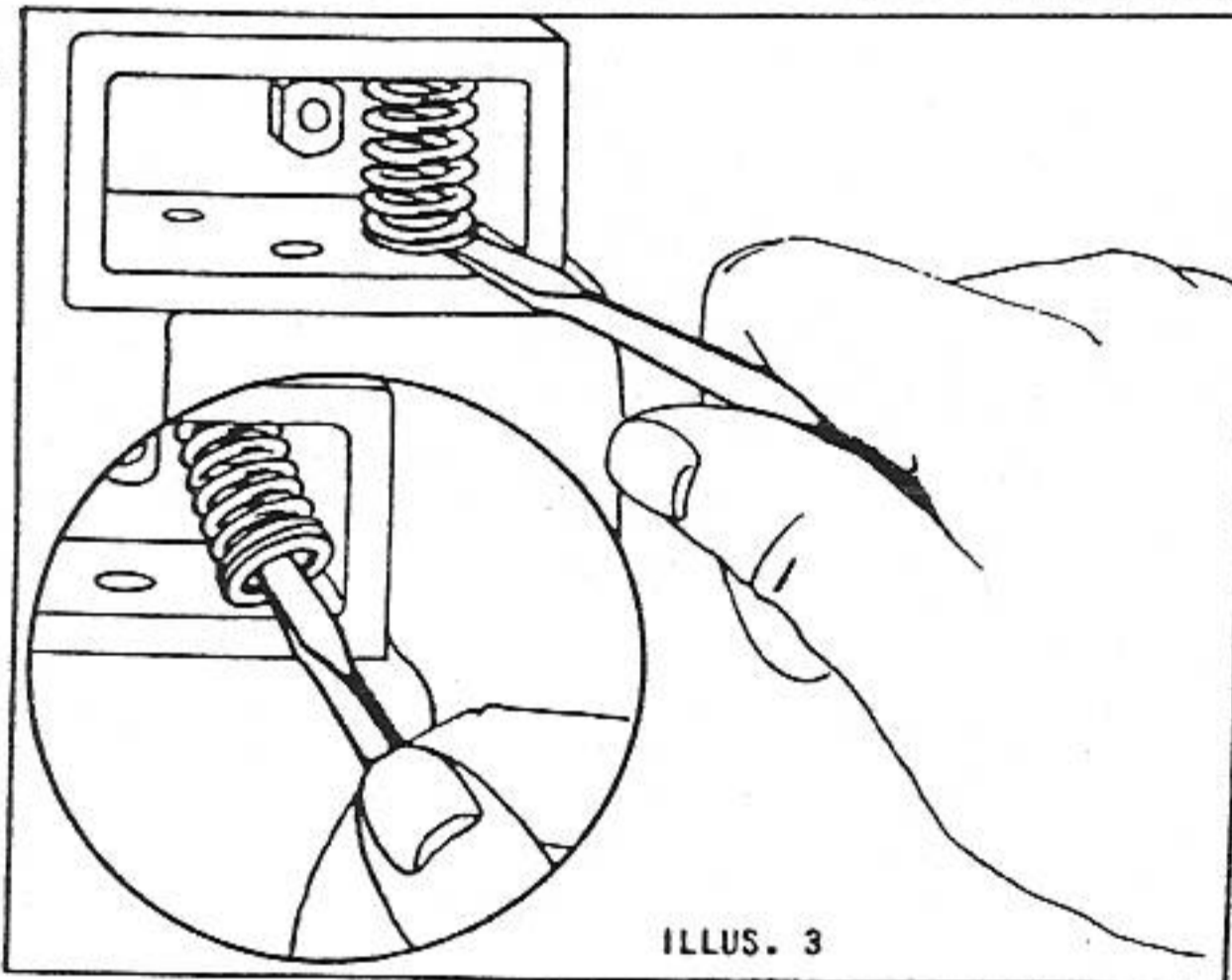
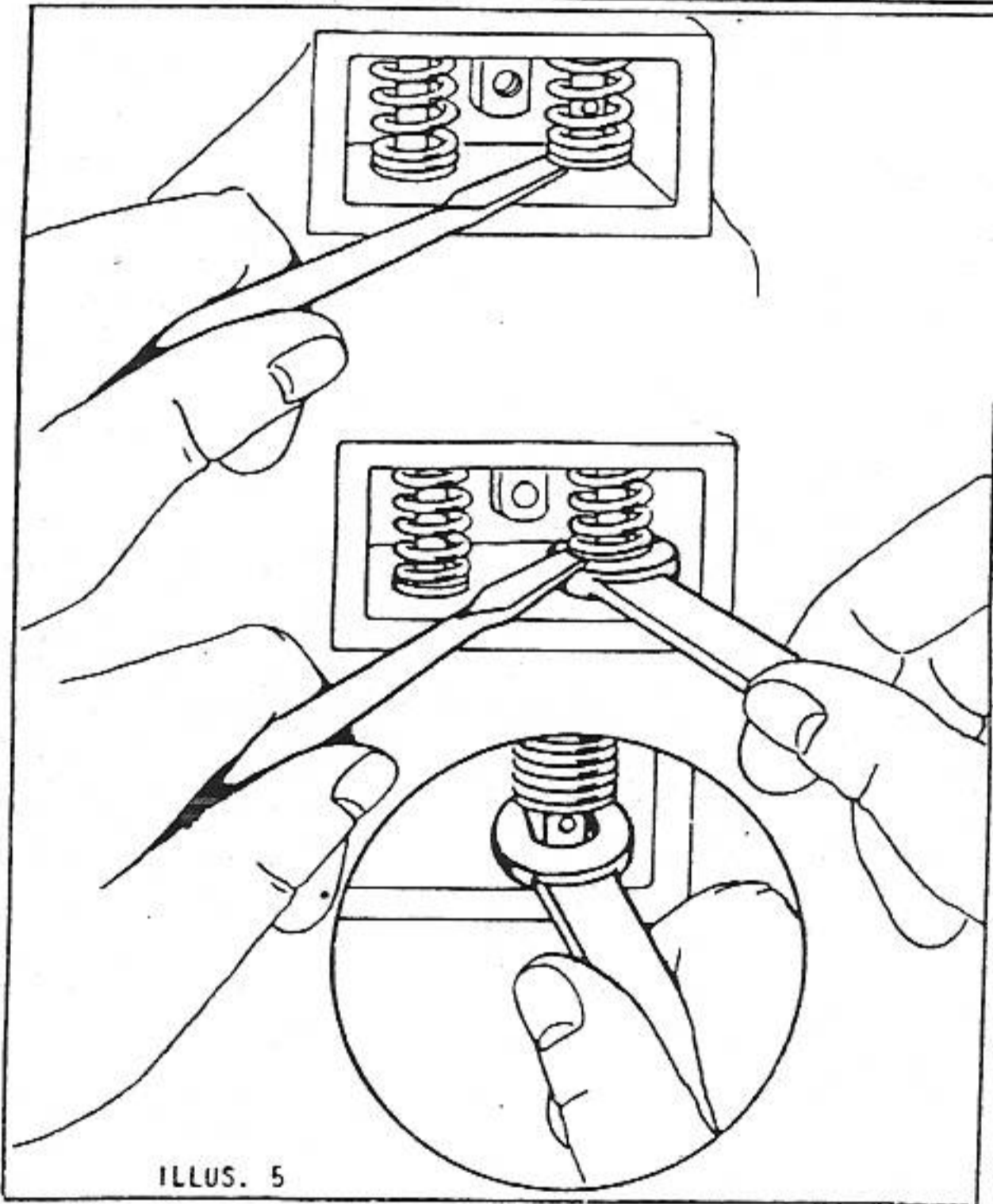
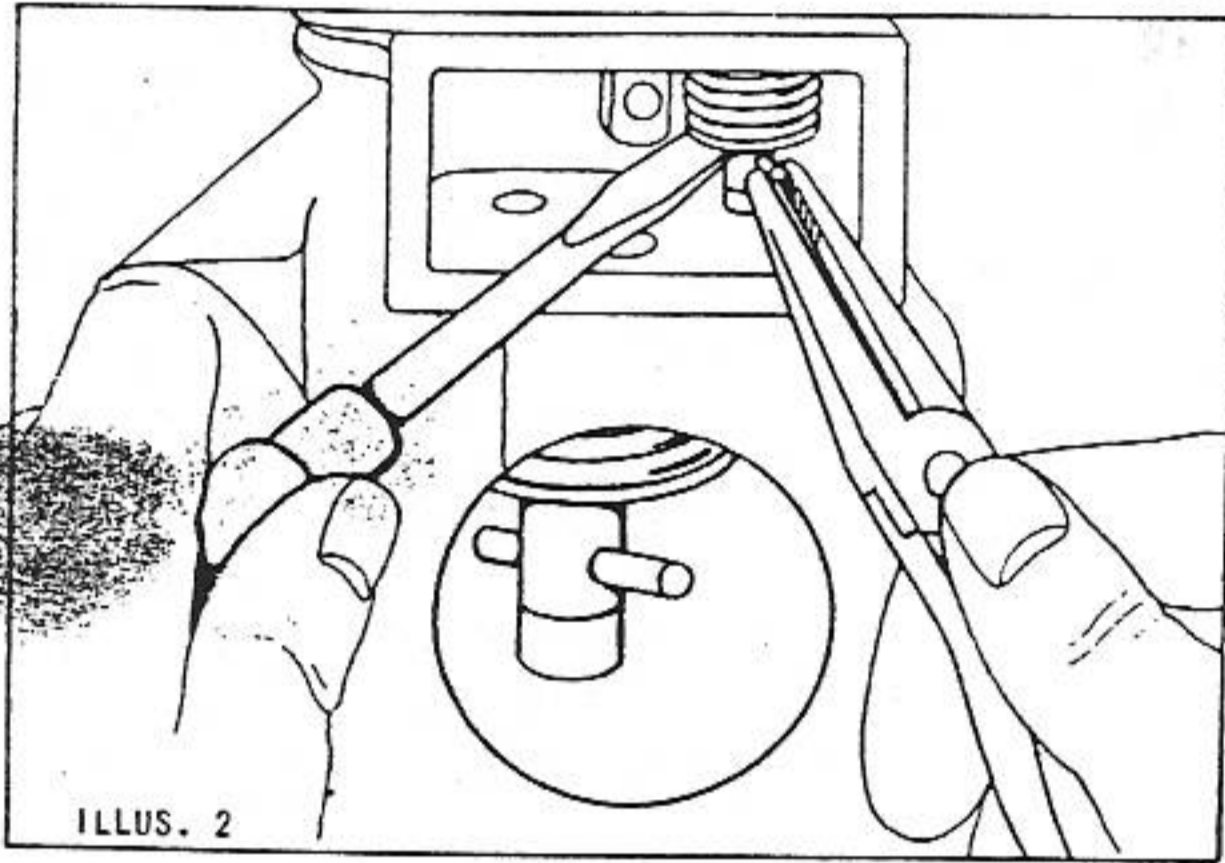
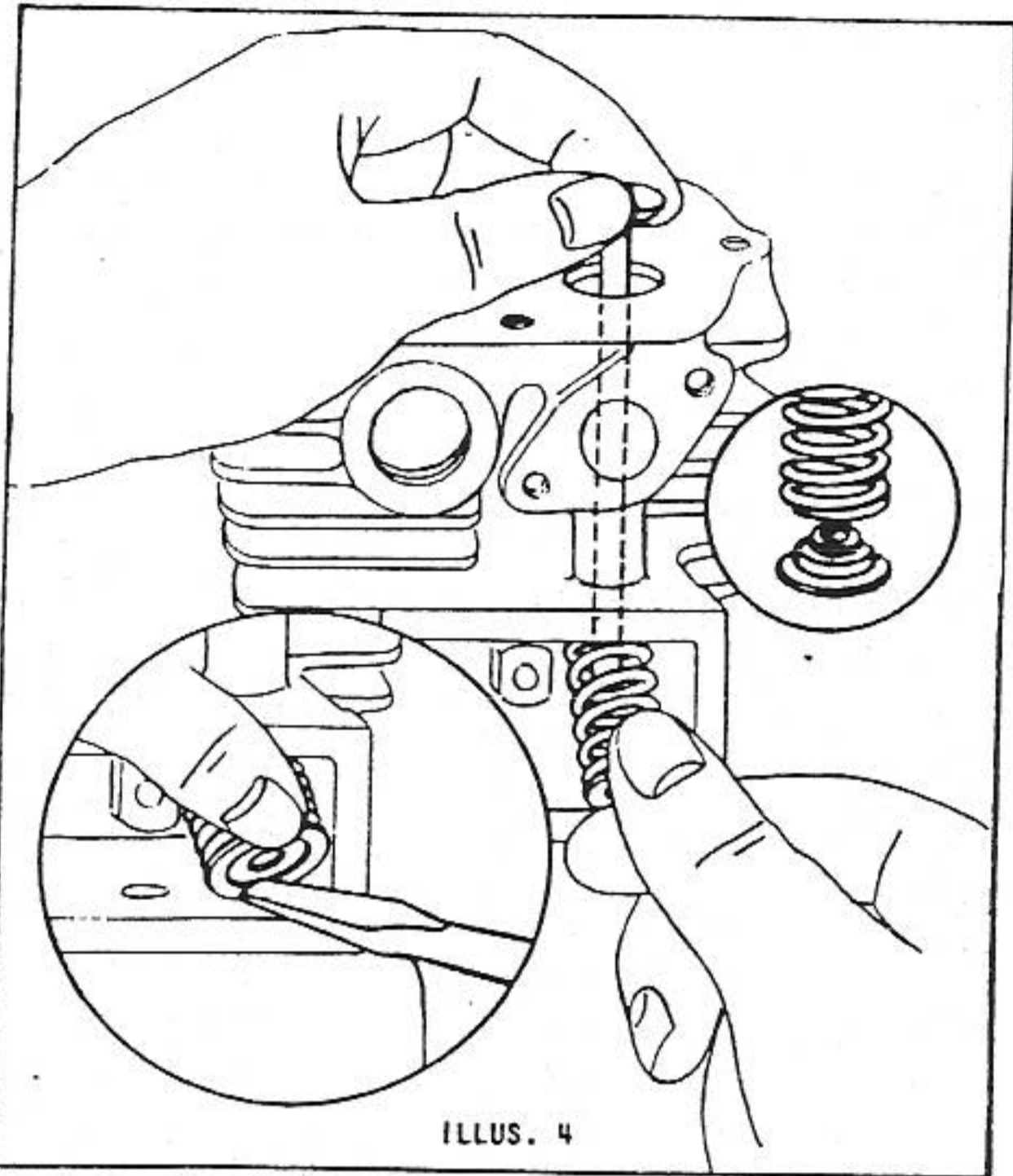
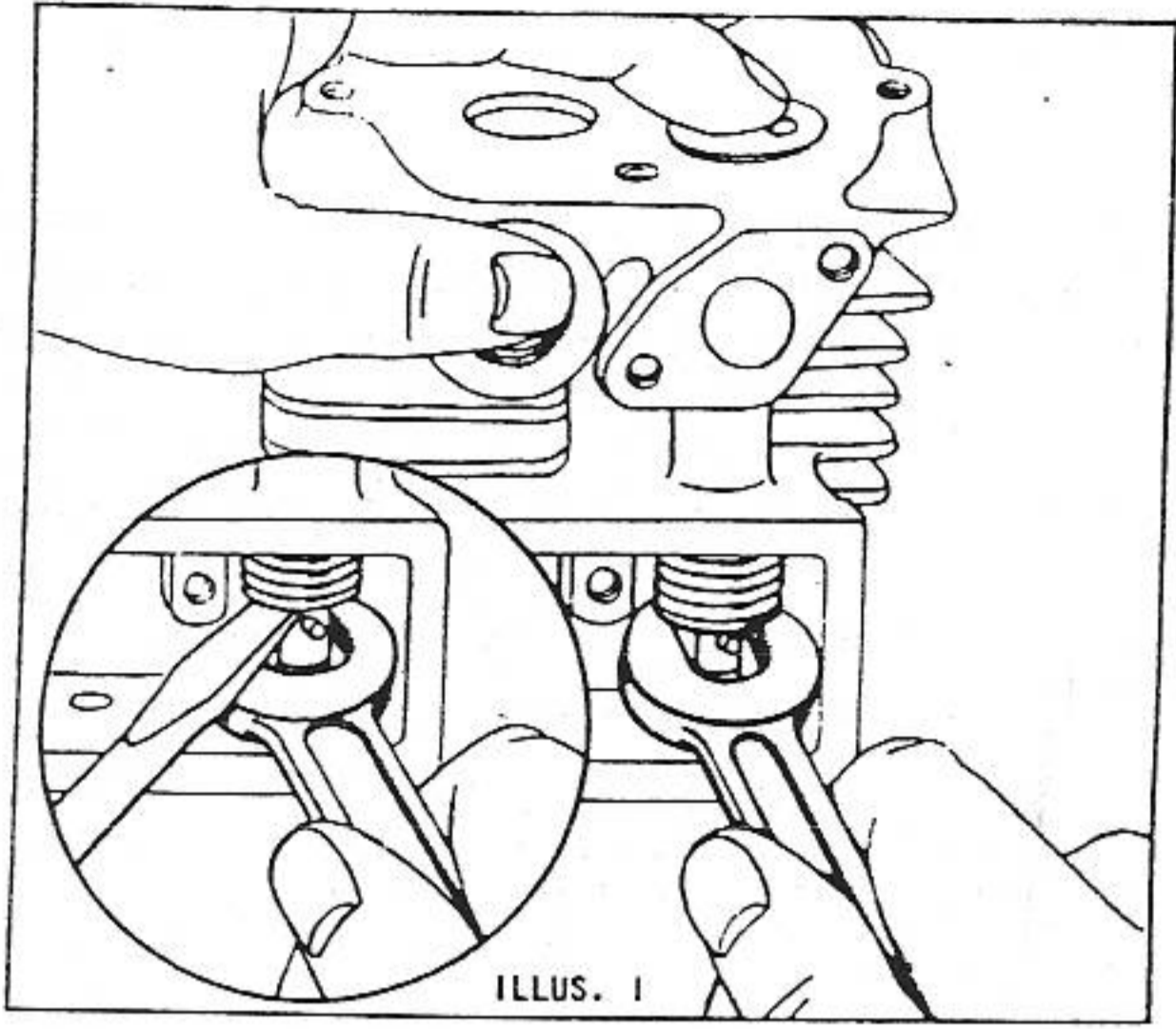


FIG. 110—REMOVING & REPLACING VALVES

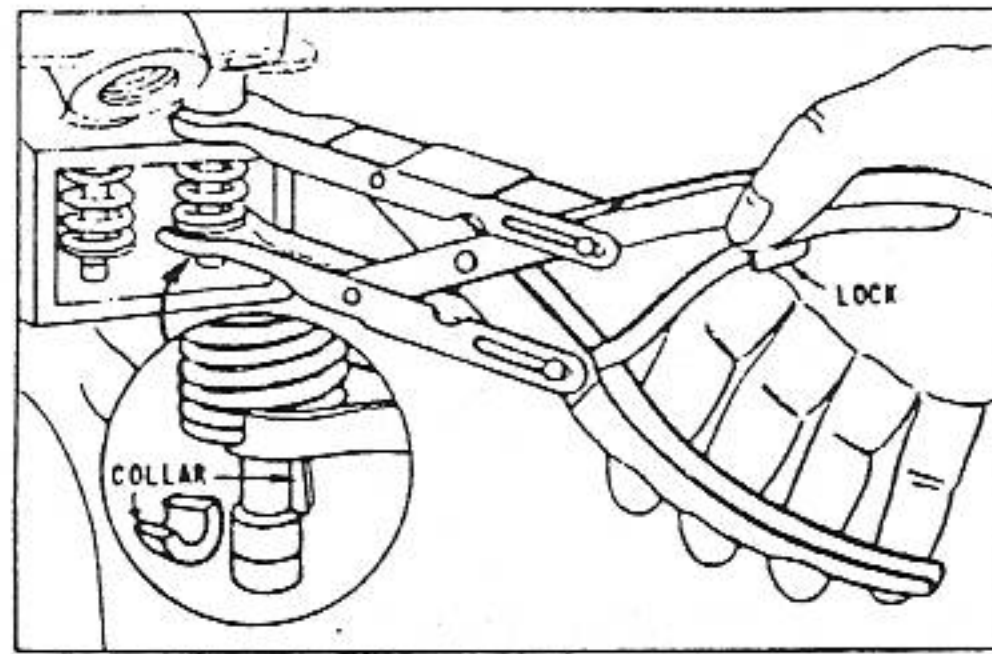


ILLUSTRATION 1

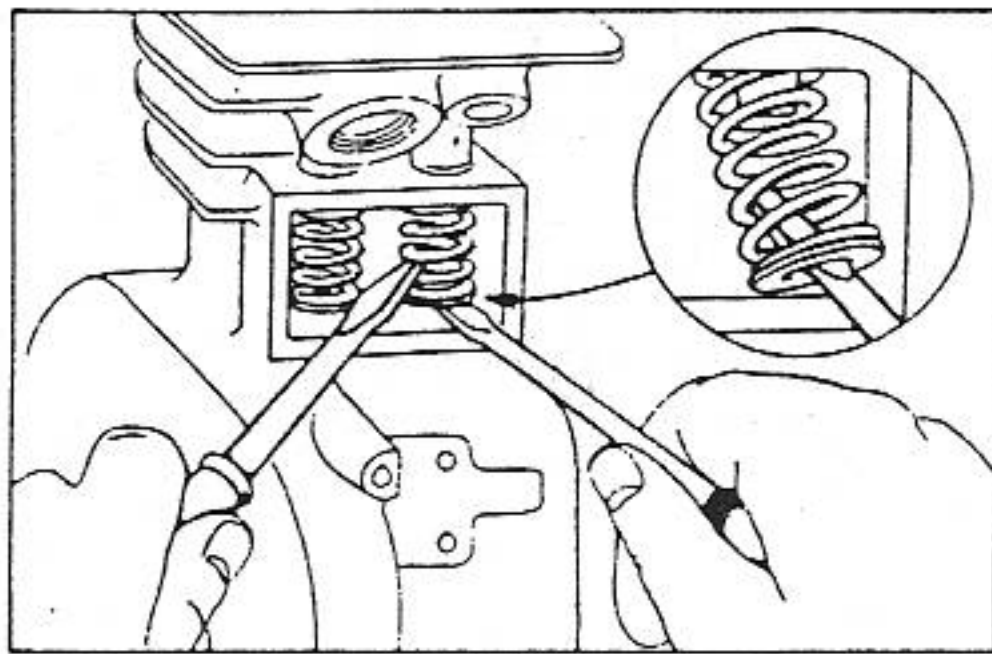


ILLUSTRATION 2

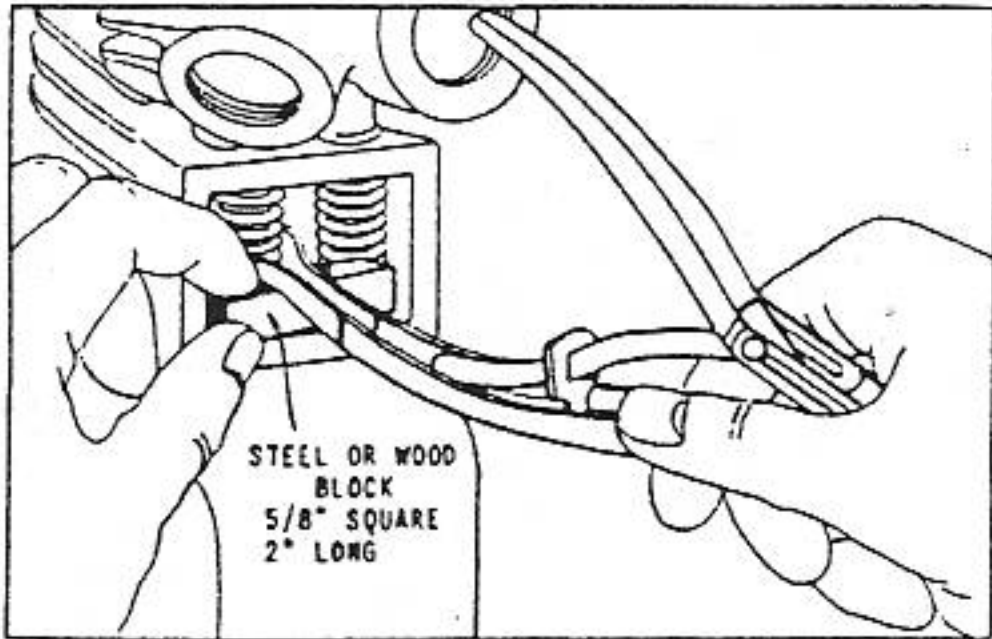


ILLUSTRATION 3

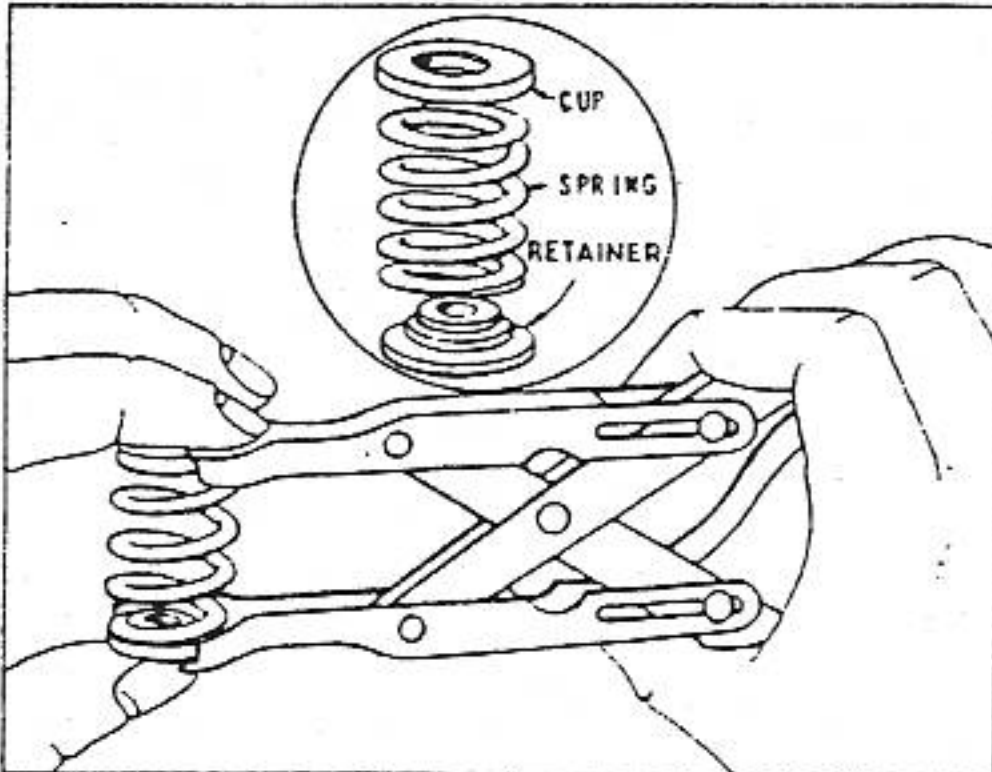


ILLUSTRATION 4

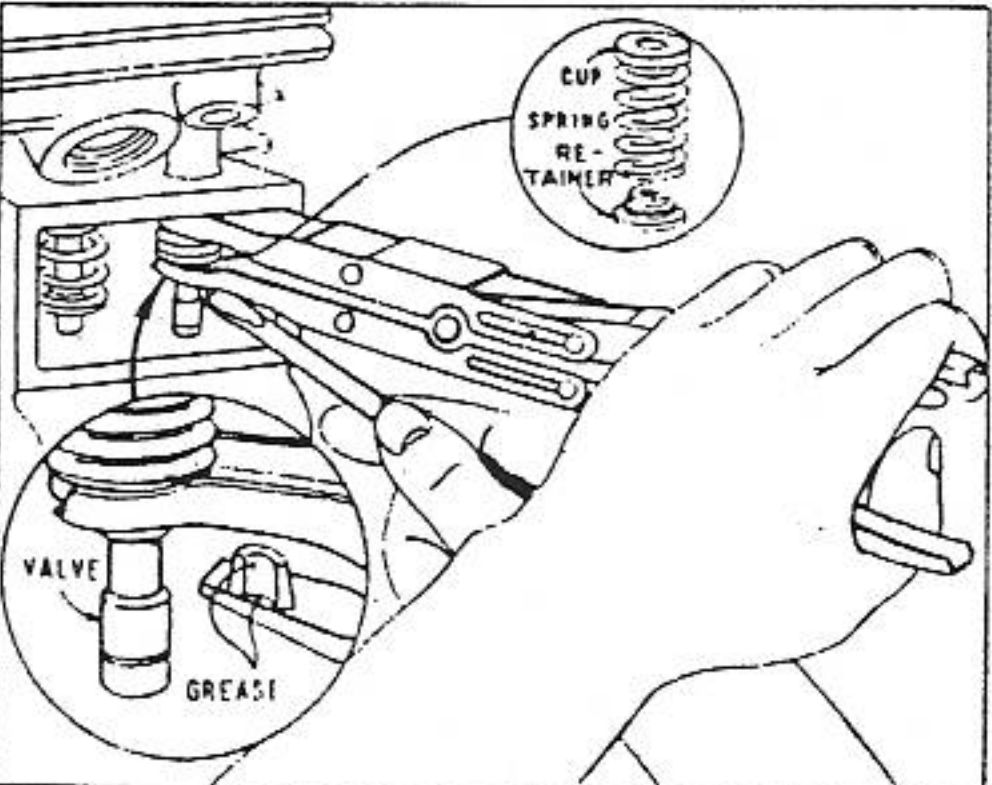


ILLUSTRATION 5

FIG. 111—REMOVING VALVES

Models A-FJ-H-K-L-M-Q-R-S-T-W-Y-Z-ZZ and Intake Valve Only on Models B-14 and 23

**To Remove**

Place valve spring compressor on top and outside of valve chamber and under valve spring retainer as shown in Fig. 111, Ill. 1. Compress valve spring compressor as much as possible and until compressor automatically locks. Tap top of valve to loosen valve spring collars and pry them out with a screw driver if necessary. Compress spring enough to release lock on spring compressor and pull out compressor. Remove valve collars from valve chamber.

To remove spring retainers, spring, and spring cup, pry them out with a screw driver as shown in Fig. 111, Ill. 2.

**Model 9 and Exhaust Valve Only on B-14 and 23**

Place valve spring compressor as shown in Fig. 111, Ill. 3 with a steel or hardwood block at the bottom of chamber. Pry up valve spring with end of compressor. Proceed with balance of operations same as above.

**To Assemble Valve Springs**

Models A-B-FJ-H-K-L-M-Q-R-S-T-W-Z-ZZ-9-14-23

Place valve spring, retainer, and cup into compressor as shown in Fig. 111, Ill. 4. (Note: Models FJ-H-L-M-S-T-Y do not use valve spring cup). Compress spring as much as possible and until compressor automatically locks. Then place spring into valve chamber as shown in Fig. 111, Ill. 5 and insert valve.

To assemble collar, put a small amount of grease on end of screw driver and inside of each half of collar as shown in Fig. 111, Ill. 5, and insert into valve stem. Compress spring enough to release lock on spring compressor and pull out compressor. See that valve spring collar fits into retainer.

**Model FH**

To remove the intake valve, file or grind off peened head of the valve stem.

To remove exhaust valve, place part (A) of Tool No. 65292-2-T1 under the valve head as shown in Fig. 112, Ill. 1. Be sure that this round tool stays under the valve head. Place slotted hole in tool (C) over the retainer as shown in Ill. 1. Press down tool (C) and release the collars that hold the retainer in place. Remove retainer and spring to take out valve.

To assemble intake valve, insert tool (A) under valve head. Replace the spring and press the retainer on part way with tool (B) as shown in Fig. 112, Ill. 1. Insert tool (C) between the end of valve stem guide and retainer above the spring. Ill. 2. This allows for the correct valve clearance. The thickness of tool (C) is about .036" which regulates proper valve opening. Press retainer down as far as possible and peen over the end of valve carefully to hold the retainer in place.

To assemble exhaust valve, insert valve and place tool (A) under valve head. Assemble spring and retainer. Compress spring with tool (C) and insert collars.

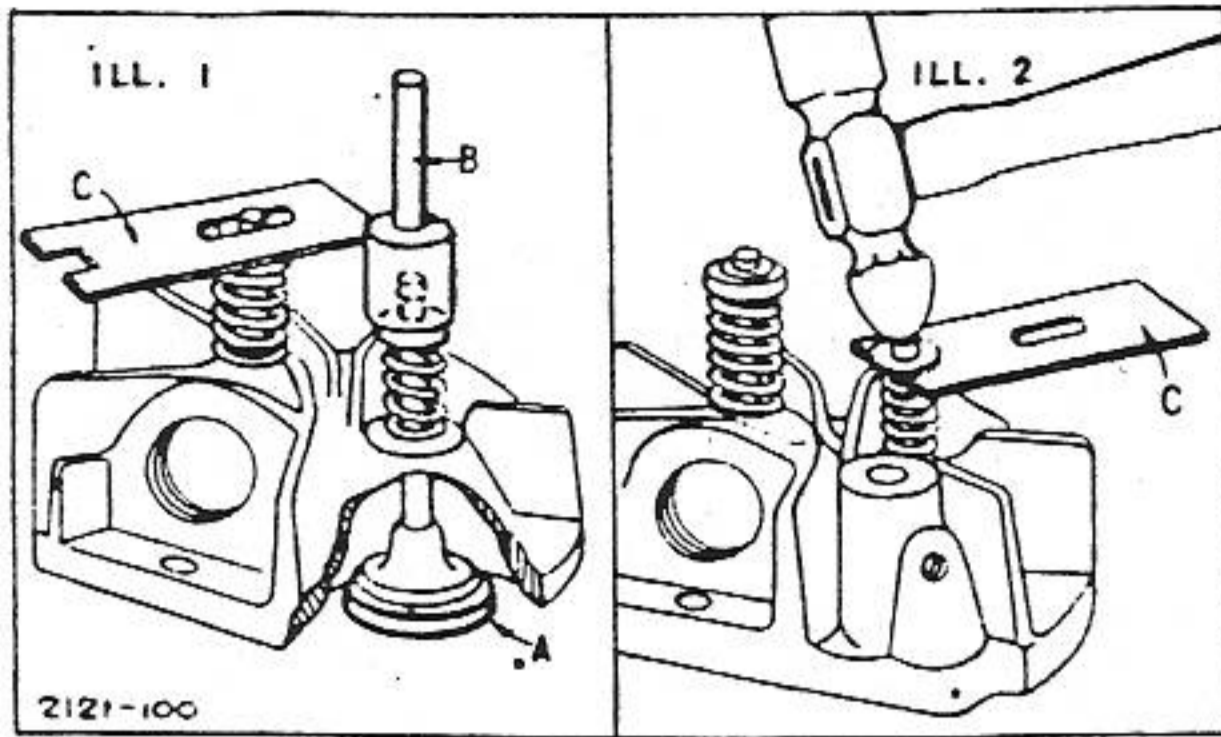


FIG. 112—REMOVING & ASSEMBLING VALVES  
MODEL FH

#### Model FI

To remove and assemble intake or exhaust valve, follow instructions for Model FH exhaust valve.

#### Model PB

Loosen compression release set screw and carburetor elbow clamp. Remove intake valve. If valve is tight use kerosene or penetrating oil to loosen.

To remove exhaust valve, lift valve spring and retainer with the end of a screw driver and with a long nose pliers, remove the pin from the valve stem. Pry spring out with screw driver. To replace valves, reverse operation.

#### To Reseat Valves

The valves should be refaced with a valve refacer and the seats reground with a good-seat grinder to an angle of 45°. Then lap valve to seat with grinding compound, just enough to remove grinding marks and to show if a good seat is obtained. If the seat is wider than shown in Table No. 7, a narrowing stone should be used. If either the seat or valve is too badly burned, it should be replaced.

TABLE NO. 7 - VALVE SEAT WIDTHS

| ENGINE MODEL | MAX. USABLE SEAT WIDTH | NEW SEAT WIDTH |
|--------------|------------------------|----------------|
| ALL MODELS   | 5/64"                  | .047" to .062" |

#### To Adjust Valve Tappet Clearance

The clearance is adjusted on most models by grinding the required amount from the end of valve stem. Fig. 113. Be sure the cam gear is turned in the proper position as explained in paragraph "To Check Tappet Clearance" and that the end of stem is ground at right angles. Special instructions are as follows:

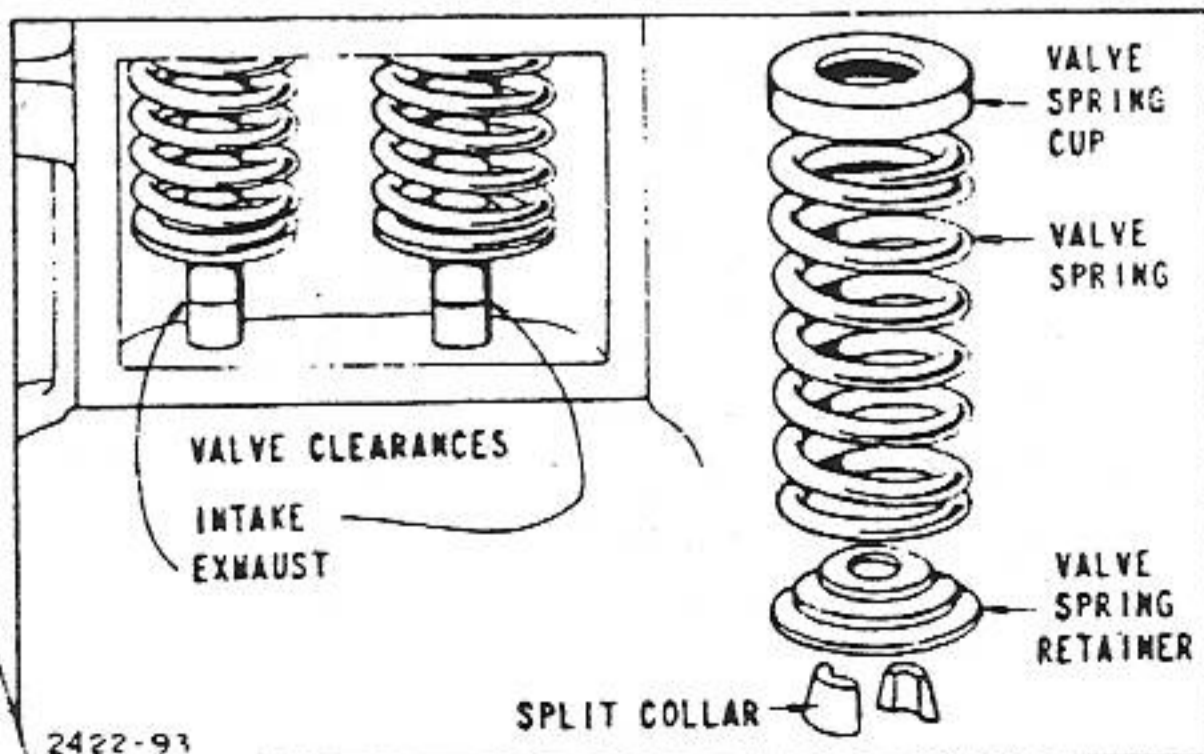


FIG. 113—CHECKING & ADJUSTING VALVES

#### Model FH

The intake valve is automatic. The exhaust valve clearance is secured by loosening the rocker arm set screw and then raising or lowering the rocker arm fork until desired clearance is obtained. It should then be locked into place with the set screw. If rocker arm fork is removed, make sure that slug (No. 65232) is placed ahead of set screw when reassembling. Fig. 114.

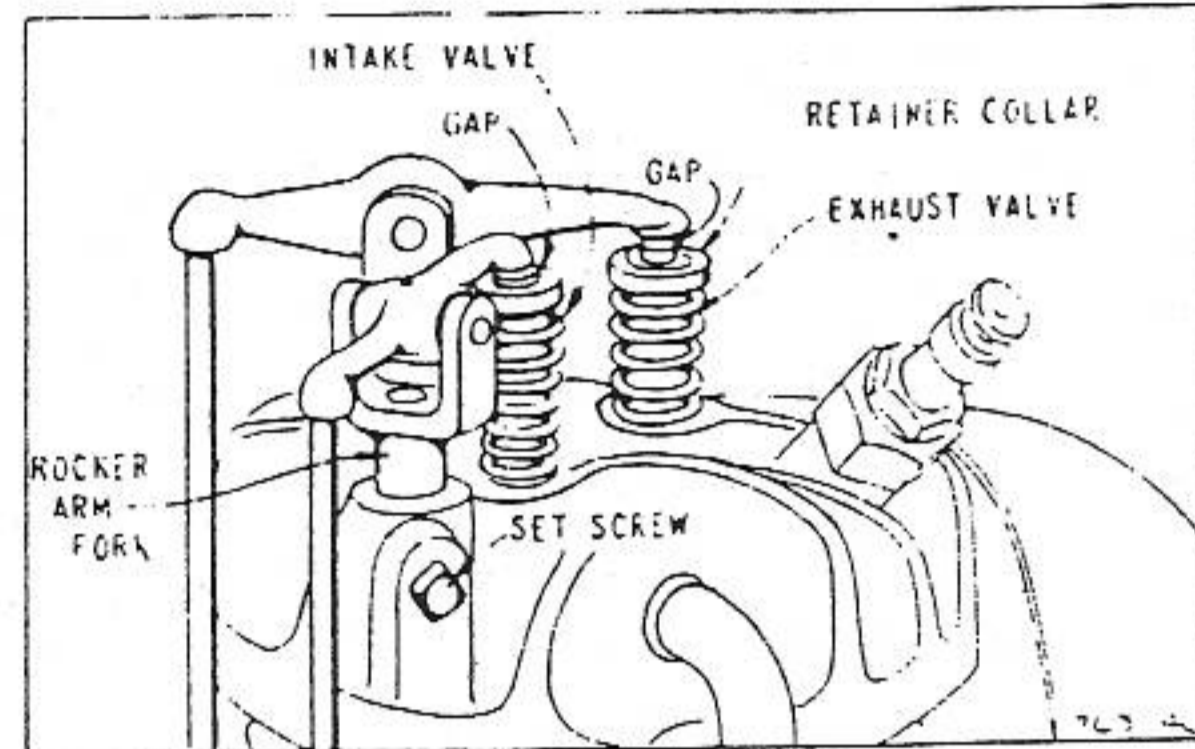


FIG. 114—ADJUSTING VALVES

#### Model FI

Valve clearances for both intake and exhaust valves are secured by following instructions for Model FH exhaust valve. Fig. 114.

#### Models K-Q-R-W-Z-ZZ

Valve clearance is adjusted by loosening cam follower locknut and turning cam follower screw to desired position. Securely tighten the cam follower locknut after adjusting valve clearance. Fig. 115.

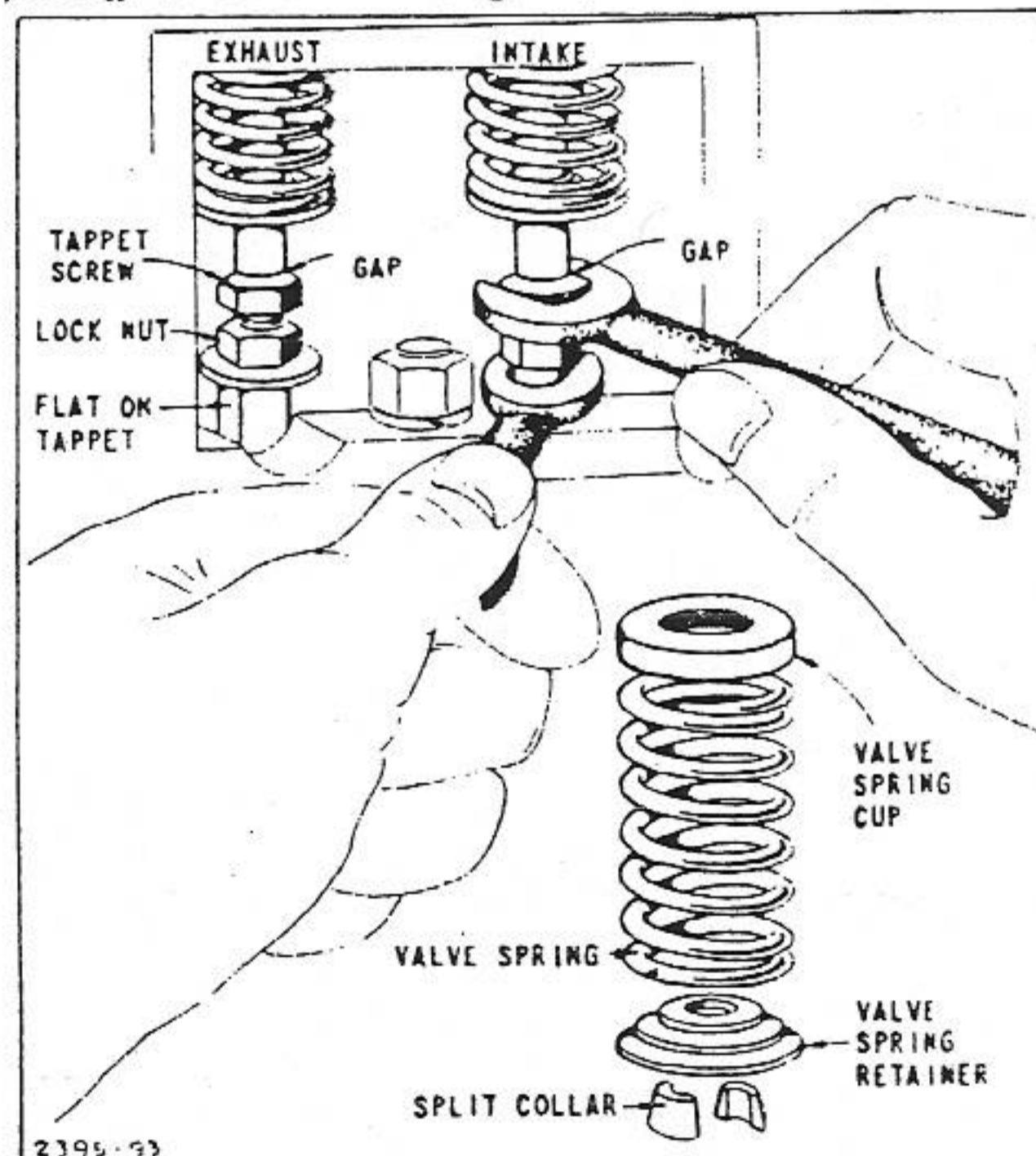


FIG. 115—ADJUSTING VALVE CLEARANCE

#### Model PB

The intake valve is automatic. Exhaust valve clearance is adjusted by loosening cam follower locknut and turning cam follower screw to desired position. Securely tighten cam follower locknut after adjusting valve clearance.

**To Check Valve Guides**

Use plug gauge to check valve guide holes for wear. See Table No. 8 for correct gauge to use on the various models. Try gauge in several positions as hole may be out of round. If gauge enters hole freely, a new valve guide must be installed.

TABLE NO. 8 - VALVE GUIDE INSPECTION TOOLS

| ENGINE MODELS                           | TO CHECK VALVE GUIDE FOR WEAR OR OUT OF ROUND USE GAUGE NUMBER |
|---|--|
| A-B-FJ-H-K-L-M-Q-R-S-T-W-Y-Z-ZZ-9-14-23 | 69829-T19  |
| IBP-N-NS-U-WM-I-WI-WMB-WMI-5-6-8        | 29738-T6   |

**To Remove Valve Guides**

The valve guides in most models are pressed into place and can be removed when worn. In other models, the valve guides are not removable. They are drilled and reamed directly through the cylinder casting and the cylinder must be counter-bored to receive the replacement valve guide. Full instructions are as follows:

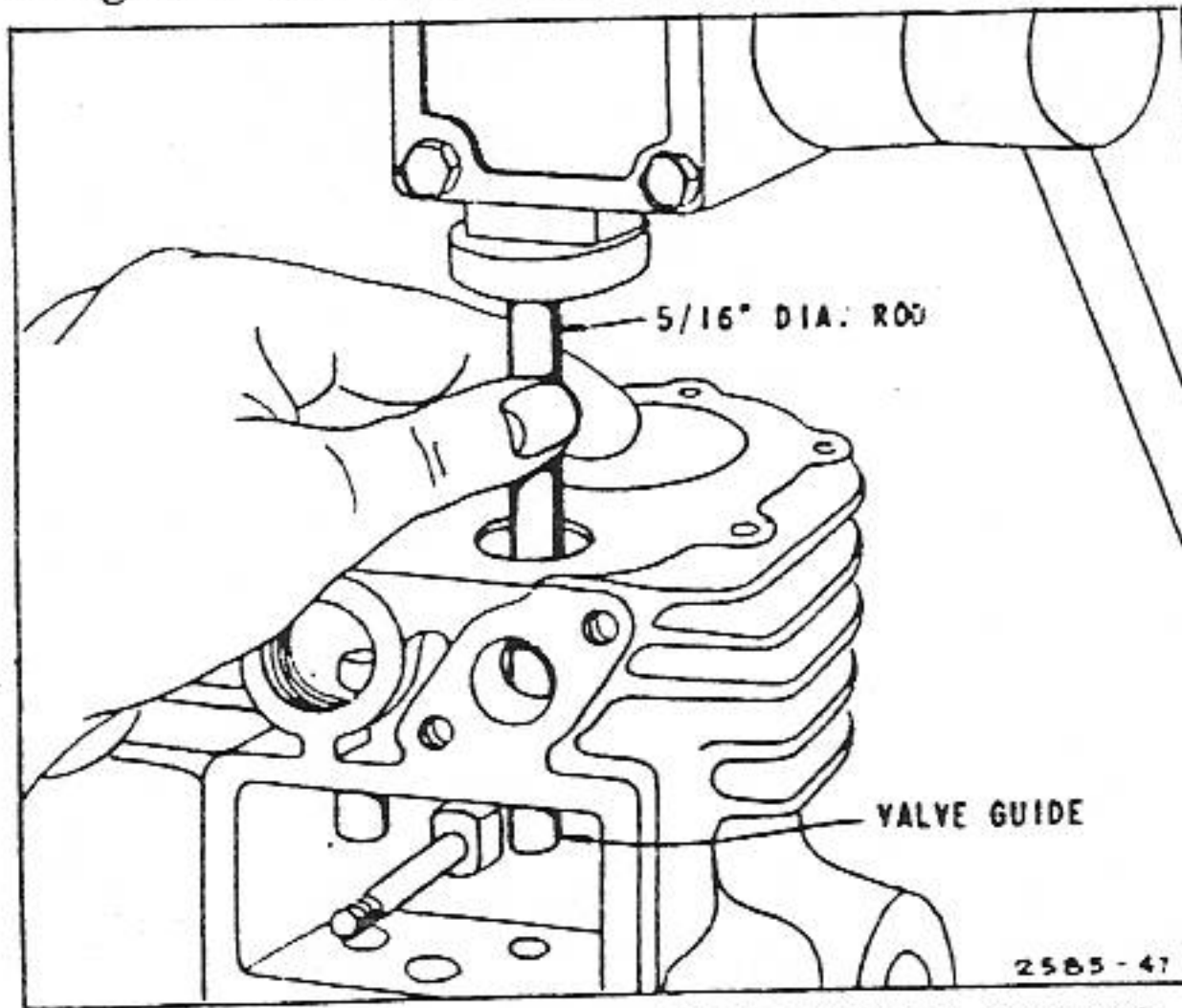


FIG. 116—PRESSING VALVE GUIDE DOWN

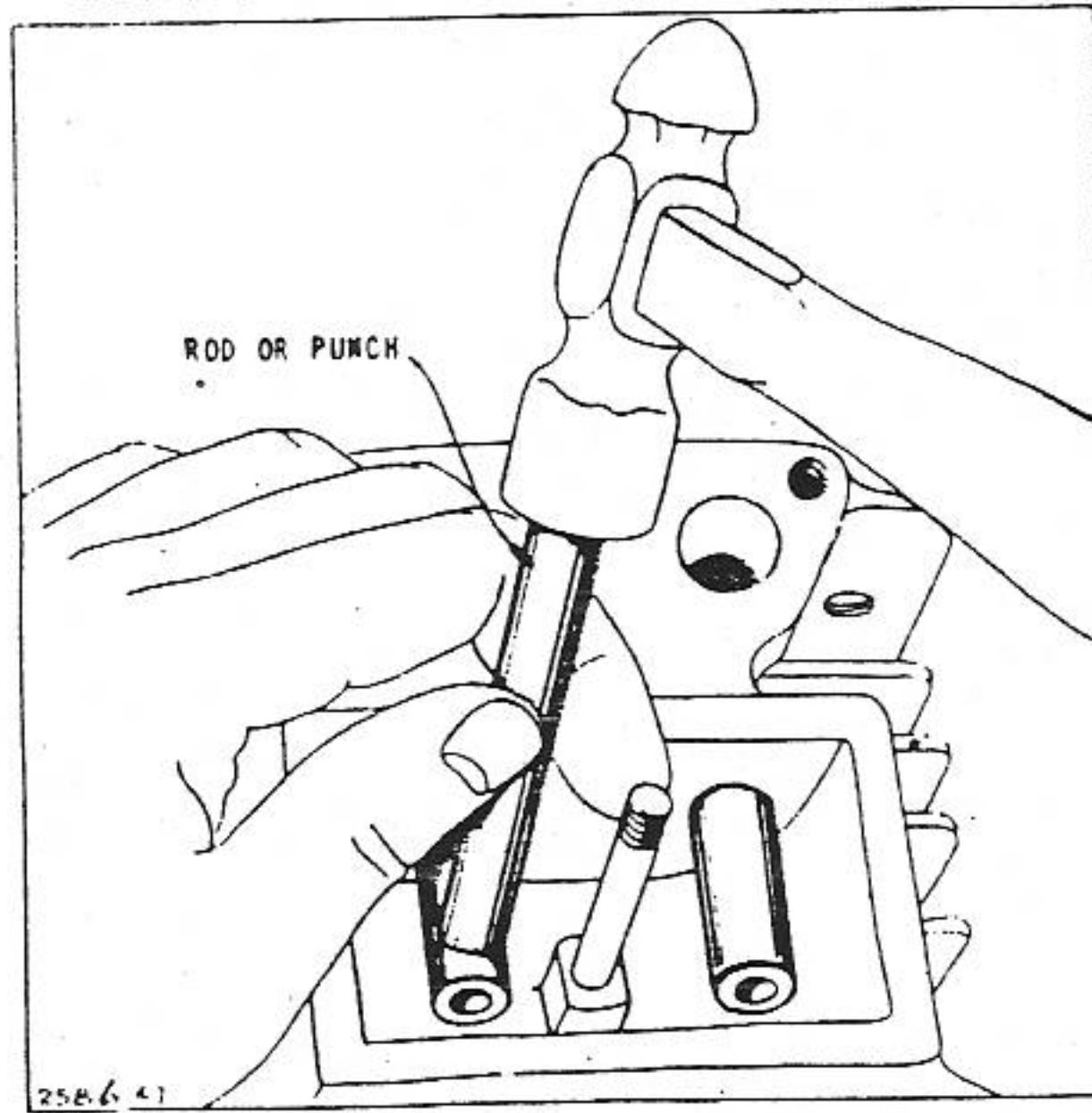


FIG. 117—BREAKING OFF LOWER HALF

**Engines With Removable Valve Guides**

Press guide halfway into valve chamber with a 5/16" rod or punch. Fig. 116. Break off lower half (Fig. 117) and drive out remainder.

NOTE: If the guide is extremely tight on Models K-R-W-Z-ZZ, remove cylinder from crankcase and push valve guide out in an arbor press.

**To Counterbore Hole for Valve Guide Engines Without Removable Valve Guides**

Counterboring should be done on a drill press so that pilot on counterbore can follow the guide and the hole will be square with the cylinder. Fig. 118. Counterbore should turn at a speed of 225 to 275 R.P.M. It may break through the sidewall, but sufficient stock will remain to hold the new guide securely. If counterbore cuts undersize so that the hole is too small for valve guide, ream the hole with counterbore reamer at not over 250 R.P.M., preferably by hand. Table 9. Proceed to install new valve guides as in the following instructions:

See Table 10 for valve guide number.

NOTE: The recommended speeds for operating drills and reamers produce best results. Lower speeds are permissible, but higher speeds may result in breakage or damage to tools. A reamer lubricated with oil will cut slightly smaller than when used dry.

TABLE NO. 9 - VALVE GUIDE COUNTERBORE TOOL

| NAME OF TOOL        | N-NS-U-6-8 | 2 1/4" & LARGER BORE ENGINES |
|---------------------|------------|------------------------------|
| COUNTERBORE         | 21309-T10  | 61348-T1-33                  |
| COUNTERBORE BUSHING | 21309-T11  | 61348-T1-93                  |

TABLE NO. 10 - VALVE GUIDE NUMBERS

| ENGINE MODEL                  | VALVE GUIDES |        |
|-------------------------------|--------------|--------|
|                               | INT.         | EXH.   |
| A                             | 210102       | 210103 |
| B                             | 210101       | 210066 |
| FJ                            | 210102       | 210103 |
| H-Y                           | 210102       | 210102 |
| I-IBP                         | 210106       | 210107 |
| K-W                           | 210105       | 21846  |
| L-M                           | 210102       | 210103 |
| N-NS-U                        | 210124       | 210125 |
| R                             | 210105       | 21846  |
| R (with non-removable guides) | 210123       | 210123 |
| S-T                           | 210102       | 210103 |
| W                             | 210105       | 21846  |
| W (with non-removable guides) | 210123       | 210123 |
| WI-WM-WMB-WMI                 | 210106       | 210107 |
| Z-ZZ                          | 210105       | 21846  |
| 5                             | 210106       | 210107 |
| 6                             | 210124       | 210125 |
| 8                             | 210124       | 210125 |
| 9                             | 210100       | 210066 |
| 14                            | 210101       | 210066 |
| 23                            | 210101       | 210067 |

another free manual from www.searctractormaterials.com

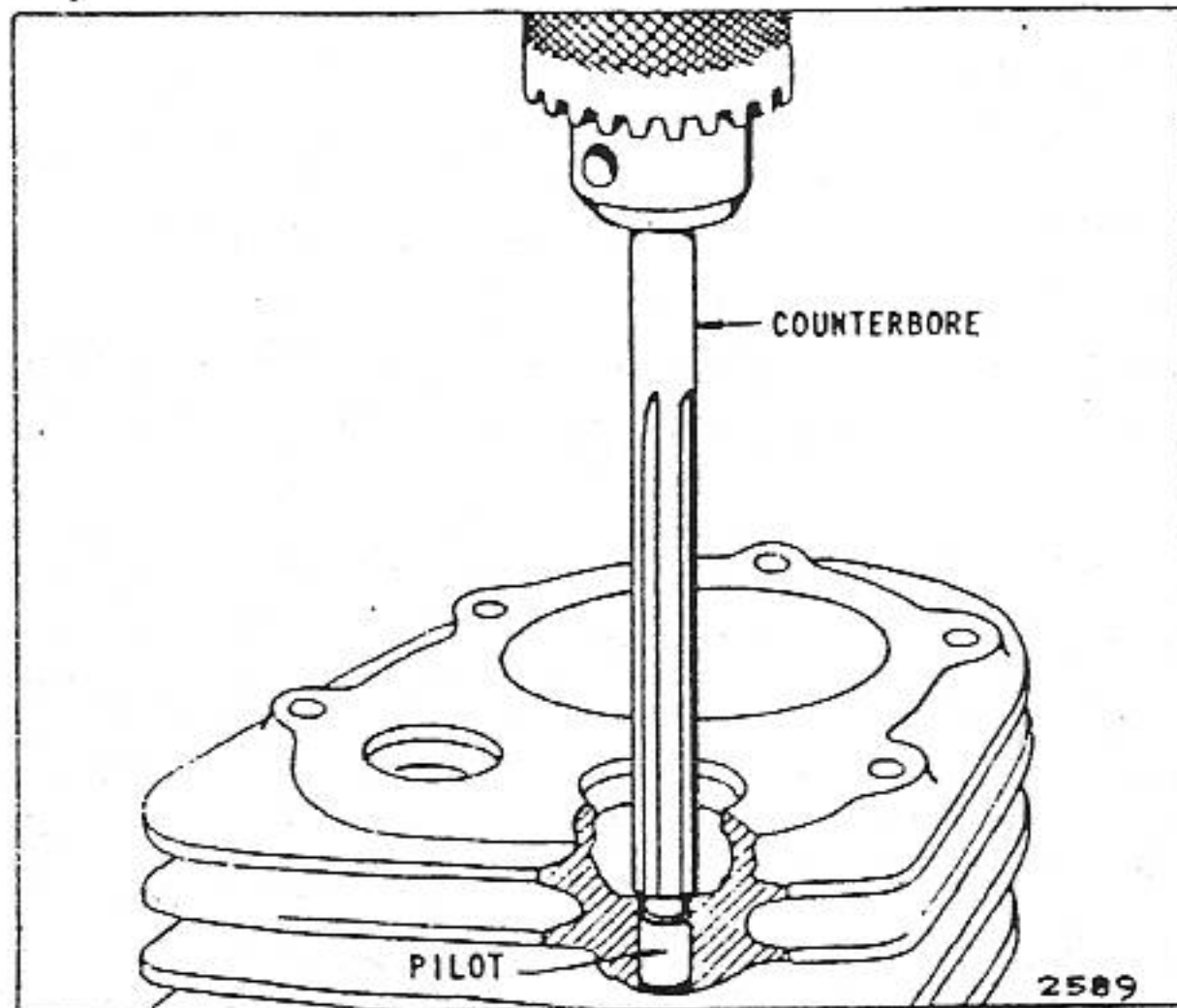


FIG. 118—COUNTERBORING FOR VALVE GUIDE

### To Install Valve Guides

The valve guides (see Table 10 for correct Part No.) are drilled and reamed to the finish size and need only be pressed into place. USE A BRASS ROD TO PREVENT PEENING THE END OF THE GUIDE. The distance from the top of the guide to the top of the cylinder should be as in Table 11. Fig. 119.

TABLE NO. 11 - DISTANCE FROM TOP OF GUIDE TO TOP OF CYLINDER

| ENGINE MODEL          | INTAKE | EXHAUST |
|-----------------------|--------|---------|
| A                     | 1/2"   | 1"      |
| B-K-Z-ZZ-14           | 3/4"   | 1-1/4"  |
| FJ-L-M-S-T            | 1/2"   | 3/4"    |
| H-Y                   | 5/8"   | 17/32"  |
| I-IBP-WM-WMB-WI-WMI-5 | 1/2"   | 7/8"    |
| N-NS-U-6              | 5/8"   | 1"      |
| R-W                   | 3/4"   | 1"      |
| 8                     | 23/32" | 1"      |
| 9                     | 25/32" | 1-1/32" |
| 23                    | 1"     | 1-1/4"  |

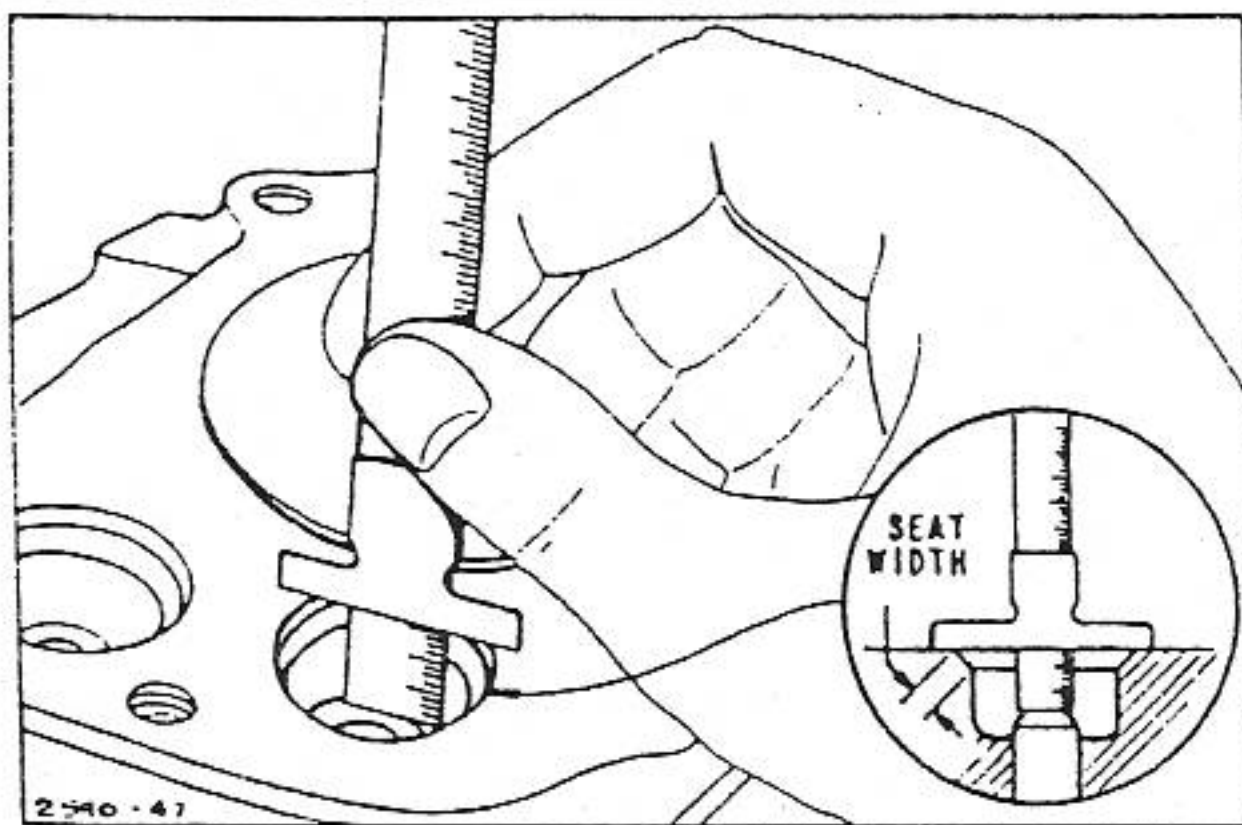


FIG. 119—CHECKING VALVE GUIDE HEIGHT

### VALVE SEATS

The valve seats in the cylinder usually are worn or pitted so little that refacing lightly with a valve seat grinder is all that is necessary. However, if they are too badly

burned or cannot be narrowed to dimension shown in Table 7, they should be replaced. Proceed as follows:

### To Remove Exhaust Valve Seat Insert

Select correct tool (Table 12) and insert seat puller nut as shown in Fig. 120. With puller nut under valve insert, place body under washer. Tighten 5/16" cap screw with a wrench until valve seat insert comes out of cylinder. Fig. 121.

TABLE NO. 12 - TOOLS FOR REMOVING VALVE SEAT INSERTS

| ENGINE MODEL | VALVE SEAT INSERT PULLER BODY | VALVE SEAT INSERT PULLER NUT |
|--------------|-------------------------------|------------------------------|
| A-9          | 61992-T6                      | 61992-T6-2                   |
| B-ZZ-14-23   | 61992-T5                      | 61992-T6-22                  |
| I-N-WI-5-6-8 | 61992-T6                      | 61992-T6-12                  |

(For above tools see Assy. No. 290914 Page 84)

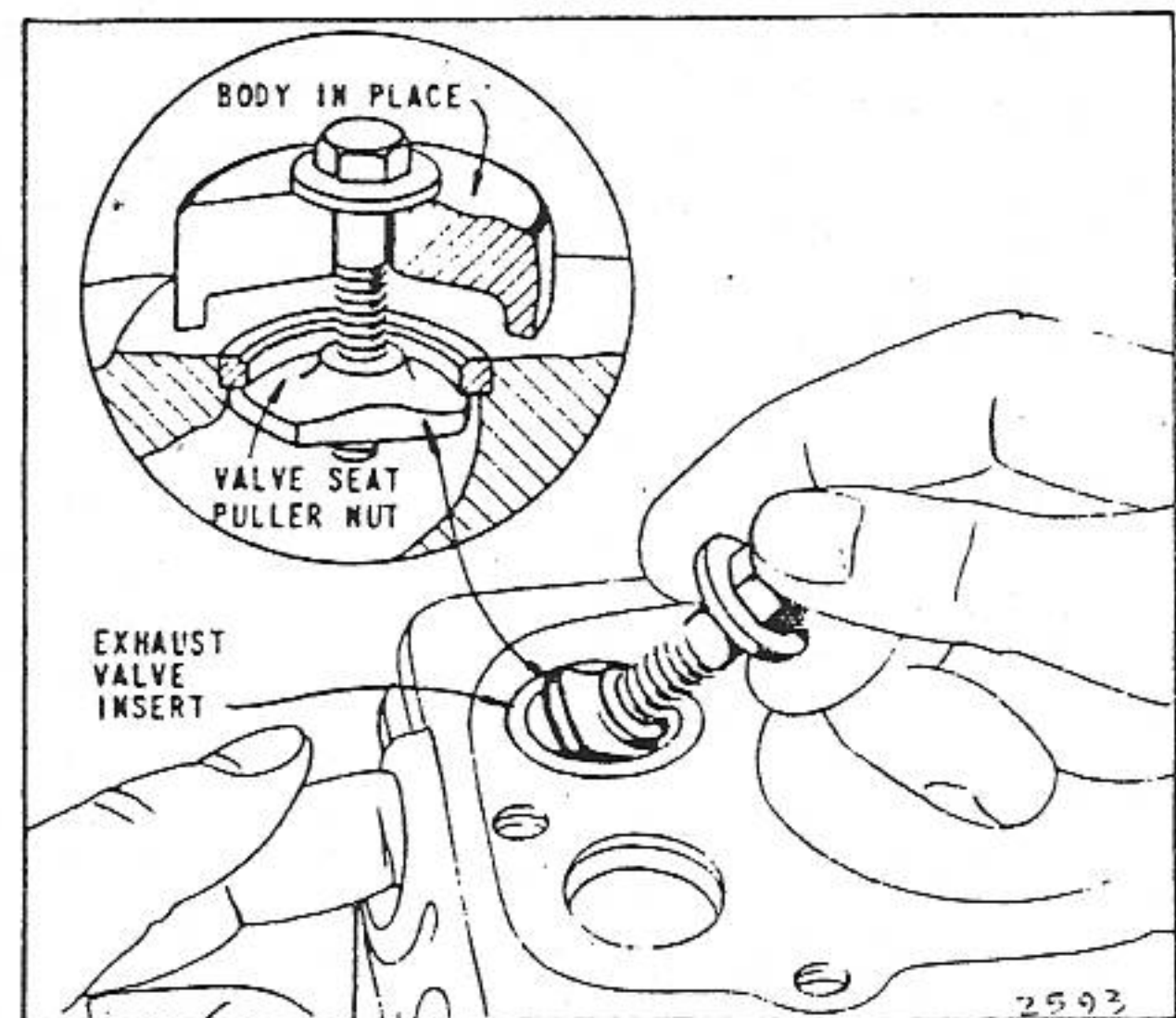


FIG. 120—INSERTING VALVE SEAT PULLER

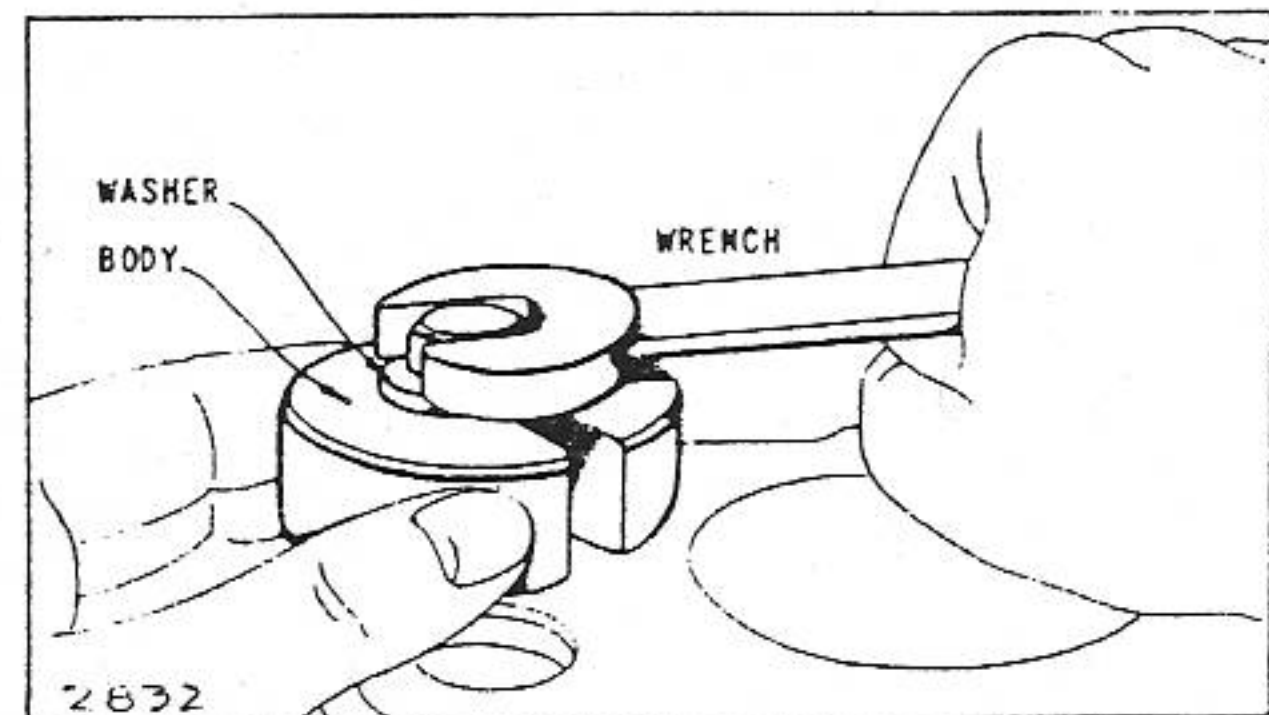


FIG. 121—REMOVING VALVE SEAT

TABLE NO. 13 - TOOLS FOR COUNTERBORING CYLINDER FOR VALVE SEAT INSERT

| ENGINE MODEL            | PILOT NO.   | COUNTERBORE CUTTER NO. |
|-------------------------|-------------|------------------------|
| A-FJ-H-L-M-S-T-Y-9      | 61348-T1-23 | 61348-T1-73            |
| B-K-R-W-Z-ZZ-14-23      | 61348-T1-23 | 61348-T1-63            |
| I-N-U-WI-WM-WMB-WMI-5-6 | 61348-T1-13 | 61348-T1-83            |
| 8                       | 61348-T1-13 | 61348-T1-73            |

**To Counterbore for Intake Valve Seat Insert**

Insert pilot in valve guide (Table 13). Use T-handle (61348-T1-122) in pilot as shown in Fig. 122.

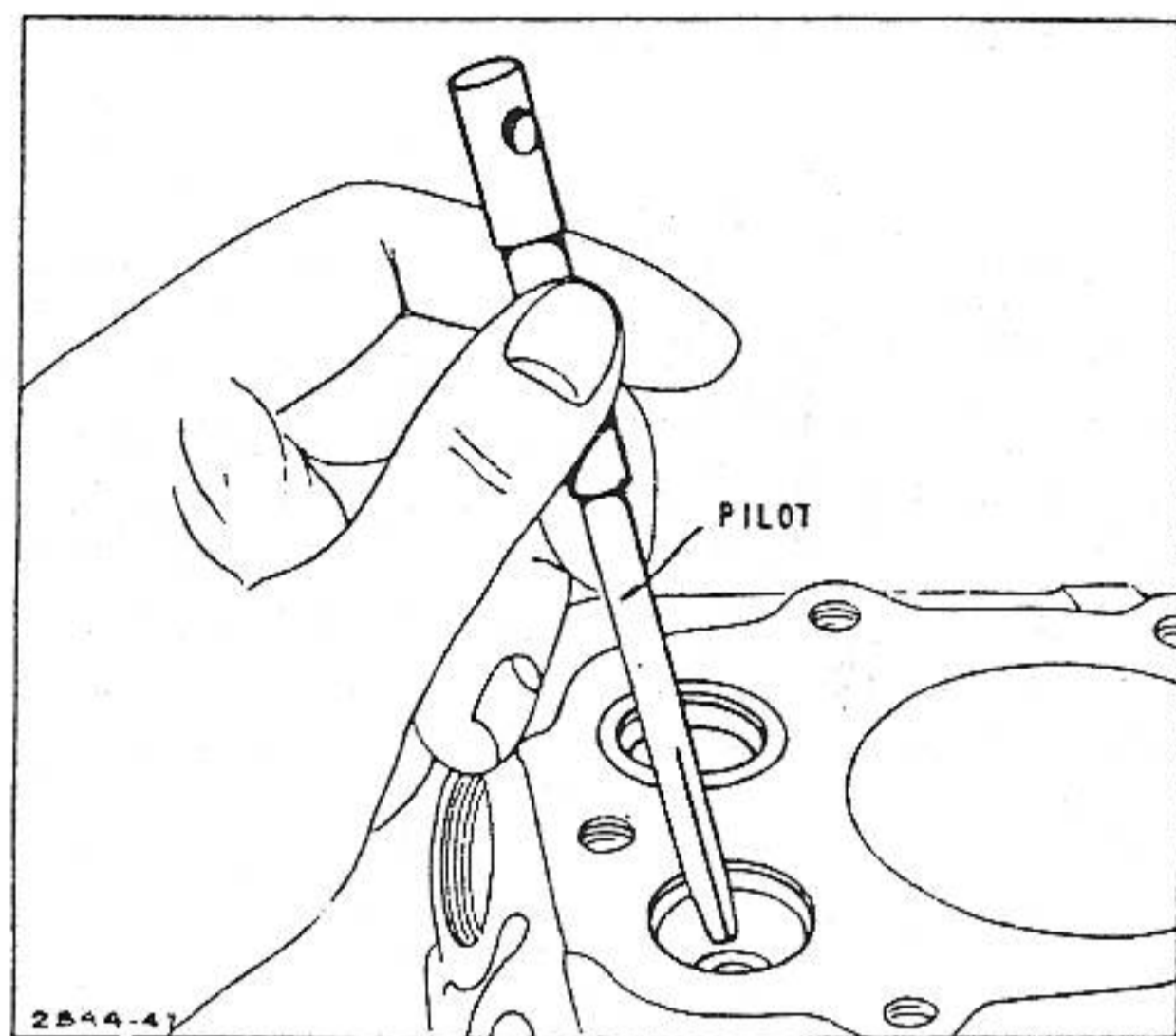


FIG. 122—INSERTING PILOT

Select correct counterbore cutter (Table 13) and place on cutter shank (61348-T1-43). Insert T-handle (61348-T1-53) in cutter shank. Fig. 123.

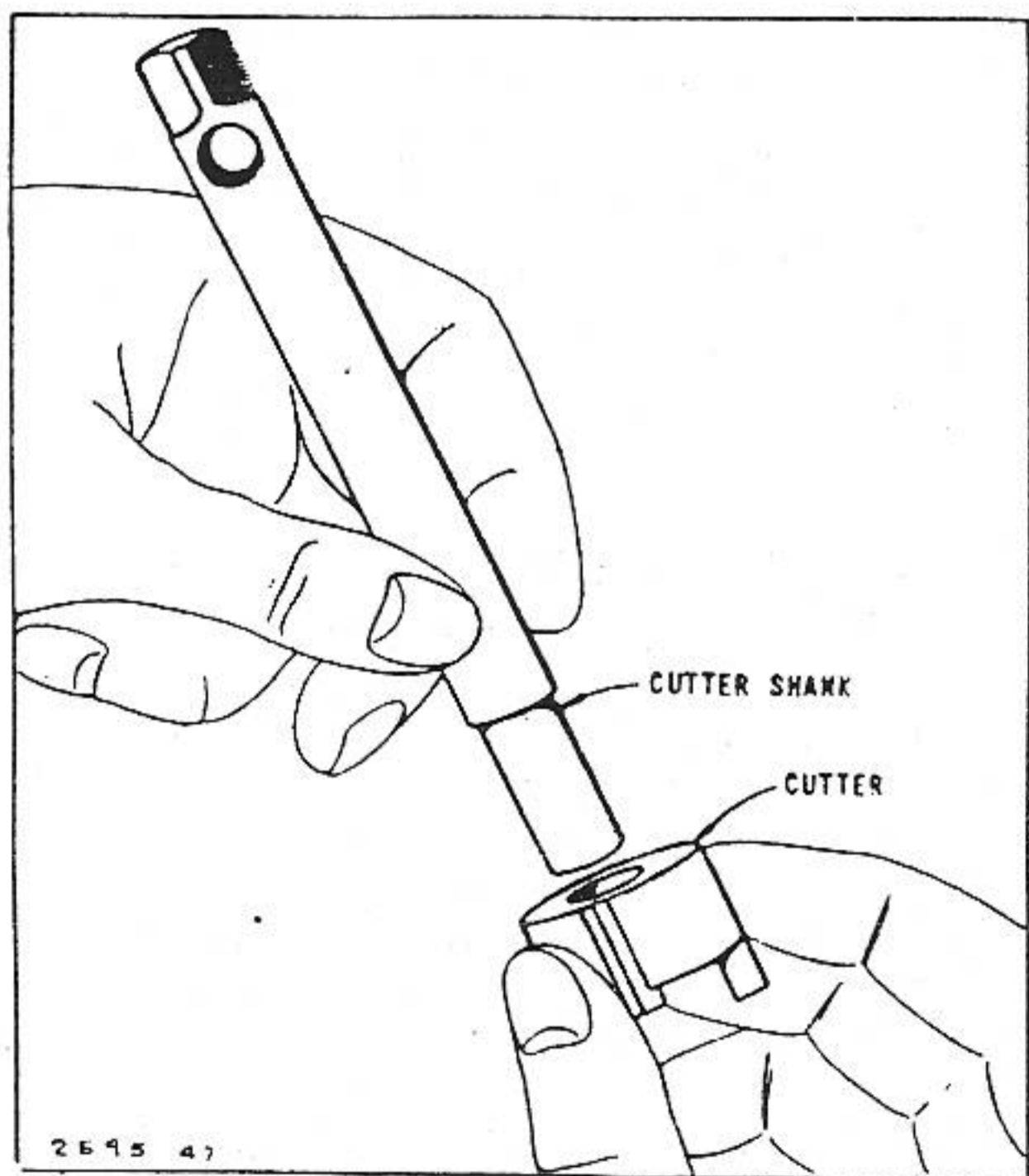


FIG. 123—INSERTING CUTTER SHANK

Counterbore the hole by hand until stop on cutter touches the top of the cylinder. Fig. 124. DO NOT force the cutter to one side or it will cut oversize. Remove cutter shank and cutter and blow out all chips. Use Knock-Out-Pin (61348-T1-102) to remove cutter from shank. Fig. 125.

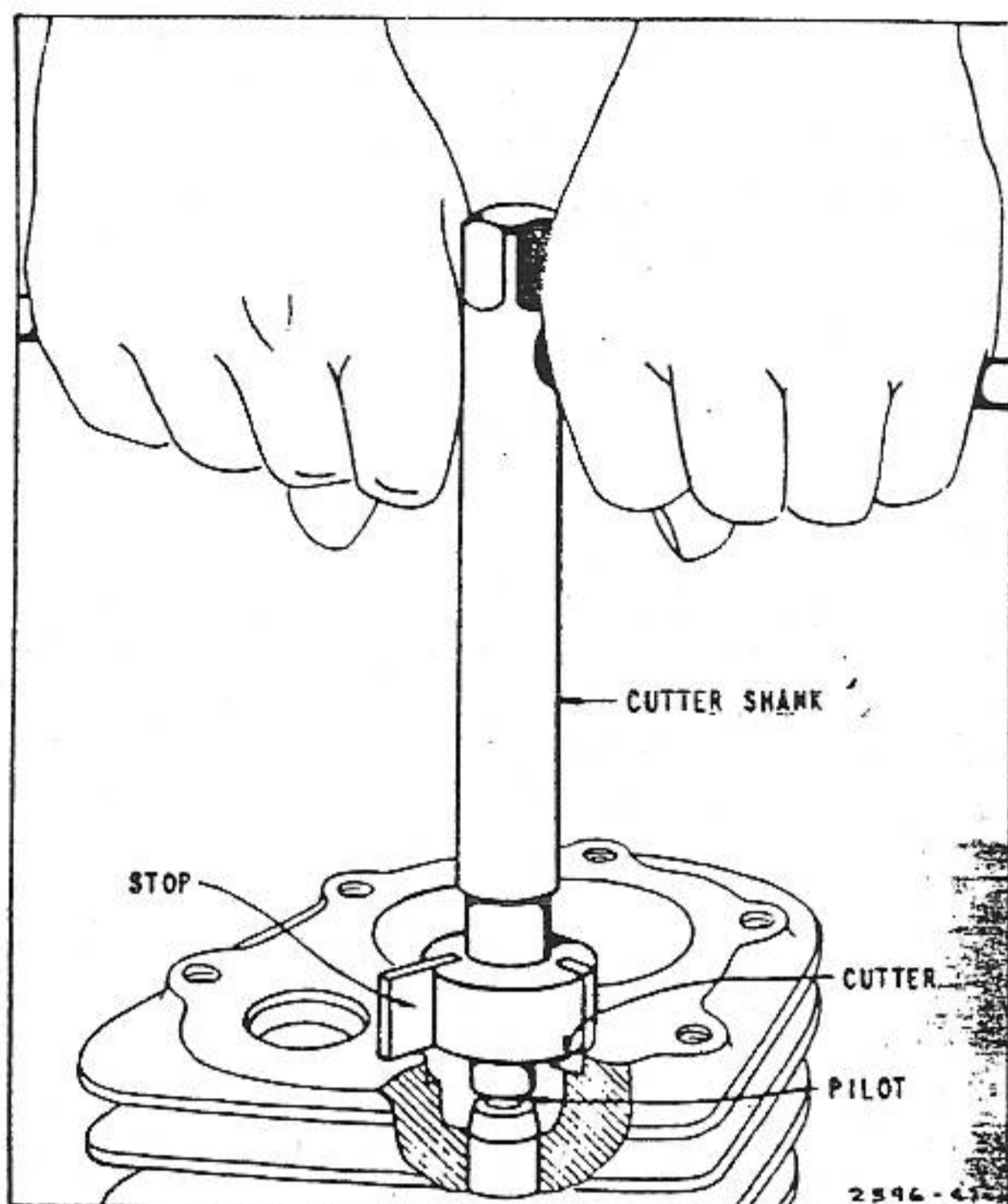


FIG. 124—COUNTERBORING VALVE SEAT

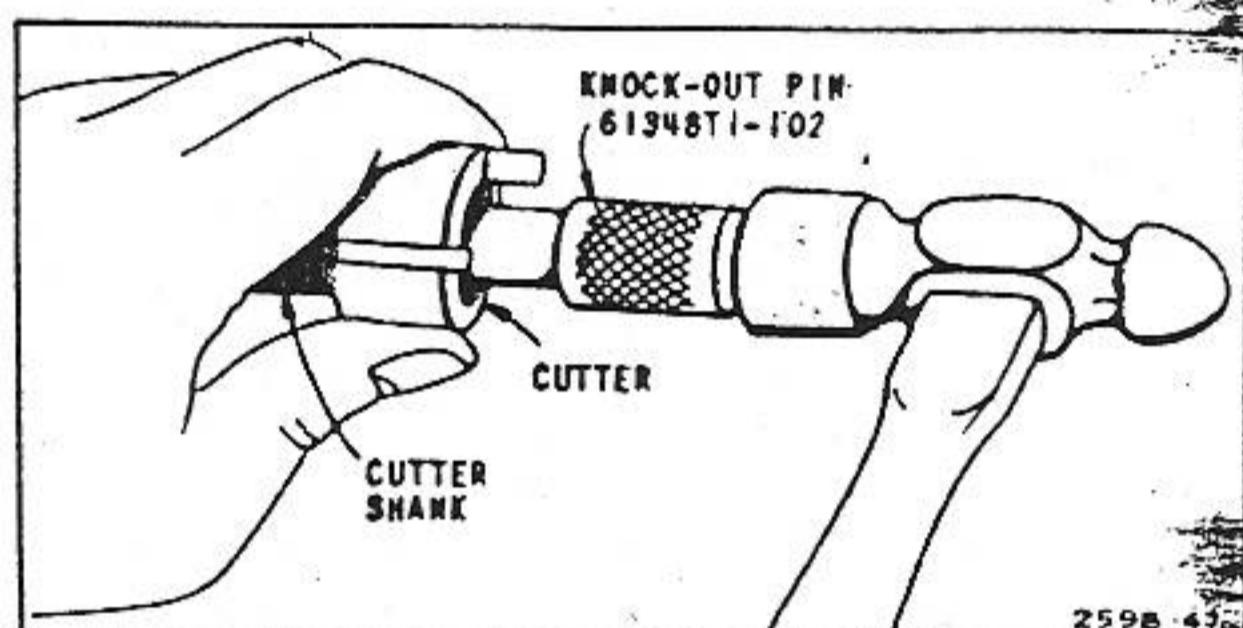


FIG. 125—REMOVING CUTTER FROM SHANK

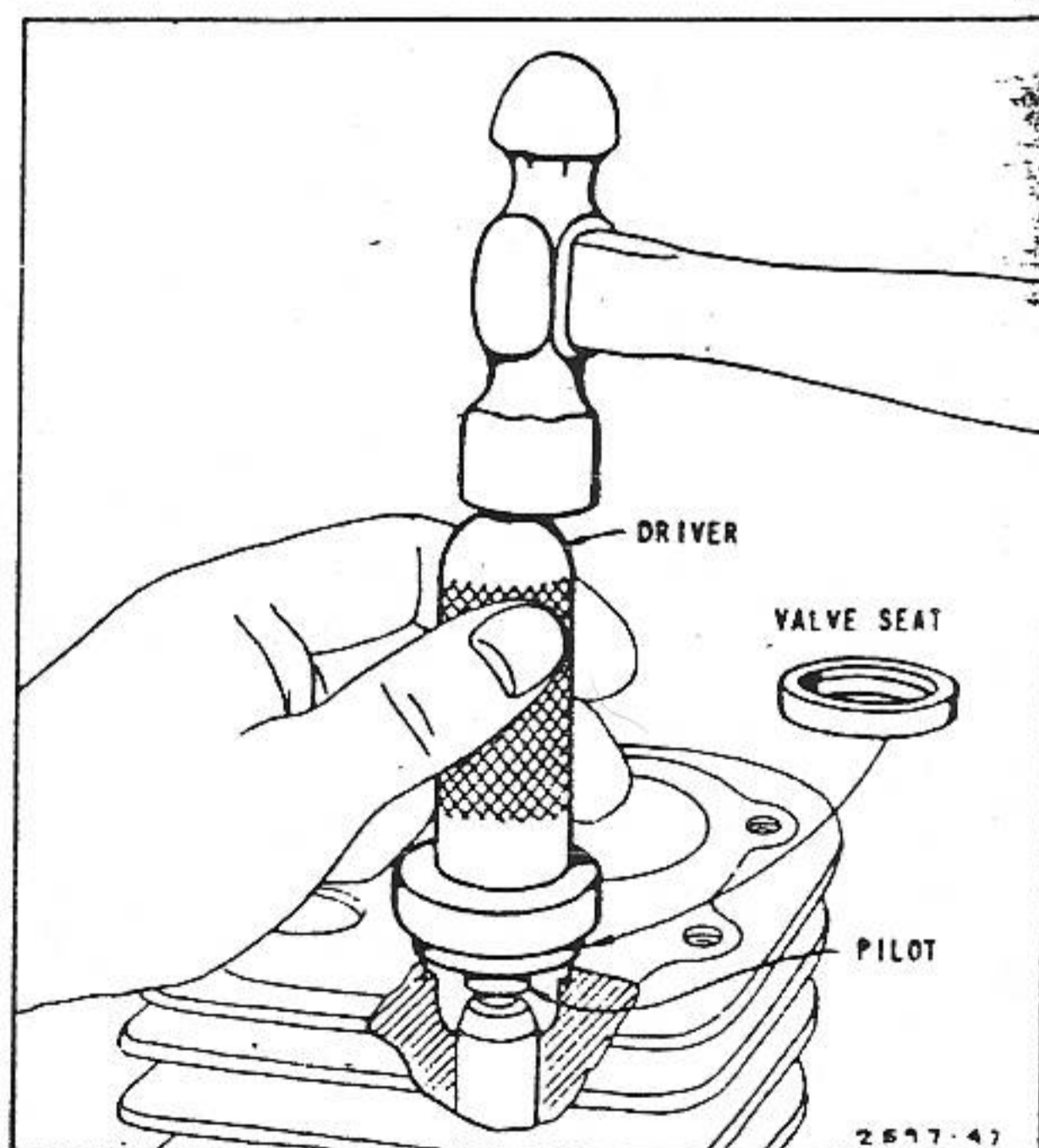


FIG. 126—DRIVING IN VALVE SEAT

**To Install Valve Seat Insert**

Use pilot and driver as shown in Table 14. Select correct valve seat insert. Place it in cylinder recess. Insert pilot in valve guide. Drive insert in with driver No. 61348-T1-112. Fig. 126. After insert is in place, use valve seat grinder lightly to be sure that valve seat and the valve guide are concentric. Then lap valve to valve seat with compound just enough to remove any grinding marks.

**To Reface Stellite Valves**

Use the same valve refacing machine as used on standard valves.

**To Grind Stellite Valve Seats**

We highly recommend the use of the valve seat reconditioning Briggs & Stratton engine kit supplied by Black & Decker Mfg. Co.

TABLE 14 - TOOLS FOR INSTALLING VALVE SEAT INSERT

| ENGINE MODEL                                  | TOOLS       |              | VALVE SEAT INSERT PART NO. |         |
|---|-------------|--------------|----------------------------|---------|
|   | PILOT       | DRIVER       | INTAKE                     | EXHAUST |
| A-FJ-H-L-M-S-T-Y-9                            | 61348-T1-23 | 61348-T1-112 | 63007                      | 63007   |
| B-K-R-W-Z-ZZ-14-23                            | 61348-T1-23 | 61348-T1-112 | 21880                      | 21880   |
| IBP-U-WMB-WMI-WBG-WMG                         | 61348-T1-13 | 61348-T1-112 | 63838                      | 63838   |
| I-N-NS-WI-WM Before following serial numbers: | 61348-T1-13 | 61348-T1-112 | 63838                      | 63838   |
| I After Serial No. 103984                     | 61348-T1-13 | 61348-T1-112 | 63838                      | 21865   |
| N After Serial No. 530498                     | 61348-T1-13 | 61348-T1-112 | 63838                      | 21865   |
| NS After Serial No. 530498                    | 61348-T1-13 | 61348-T1-112 | 63838                      | 21865   |
| WI After Serial No. 538680                    | 61348-T1-13 | 61348-T1-112 | 63838                      | 21865   |
| WMB After Serial No. 538680                   | 61348-T1-13 | 61348-T1-112 | 63838                      | 21865   |
| 5-6   | 61348-T1-13 | 61348-T1-112 | 63838                      | 21865   |
| 8   | 61348-T1-13 | 61348-T1-112 | 210135                     | 21865   |

**To Time Valves**

To properly time the valves, assemble the crankshaft so that the timing mark on the collar of the crankshaft is in line with that on the cam gear. Figs. 127 and 128.

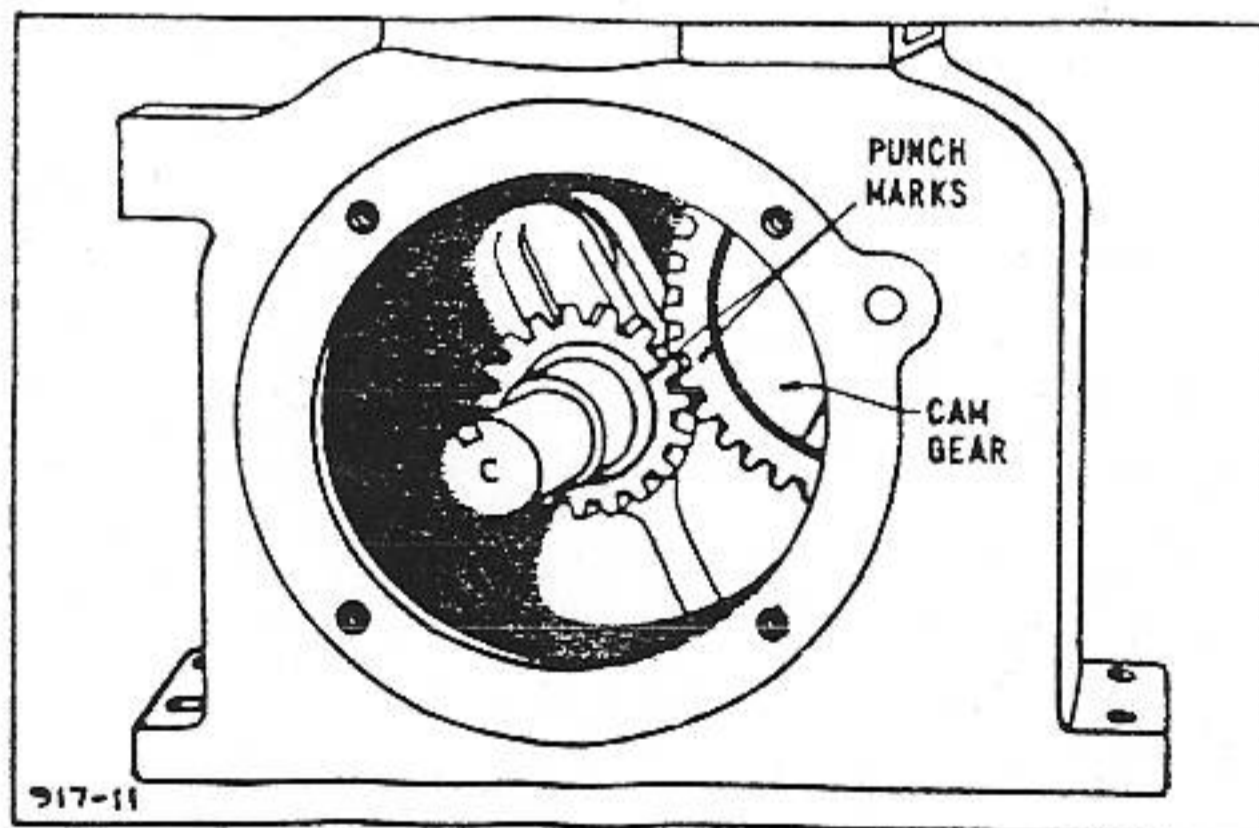


FIG. 127—VALVE TIMING

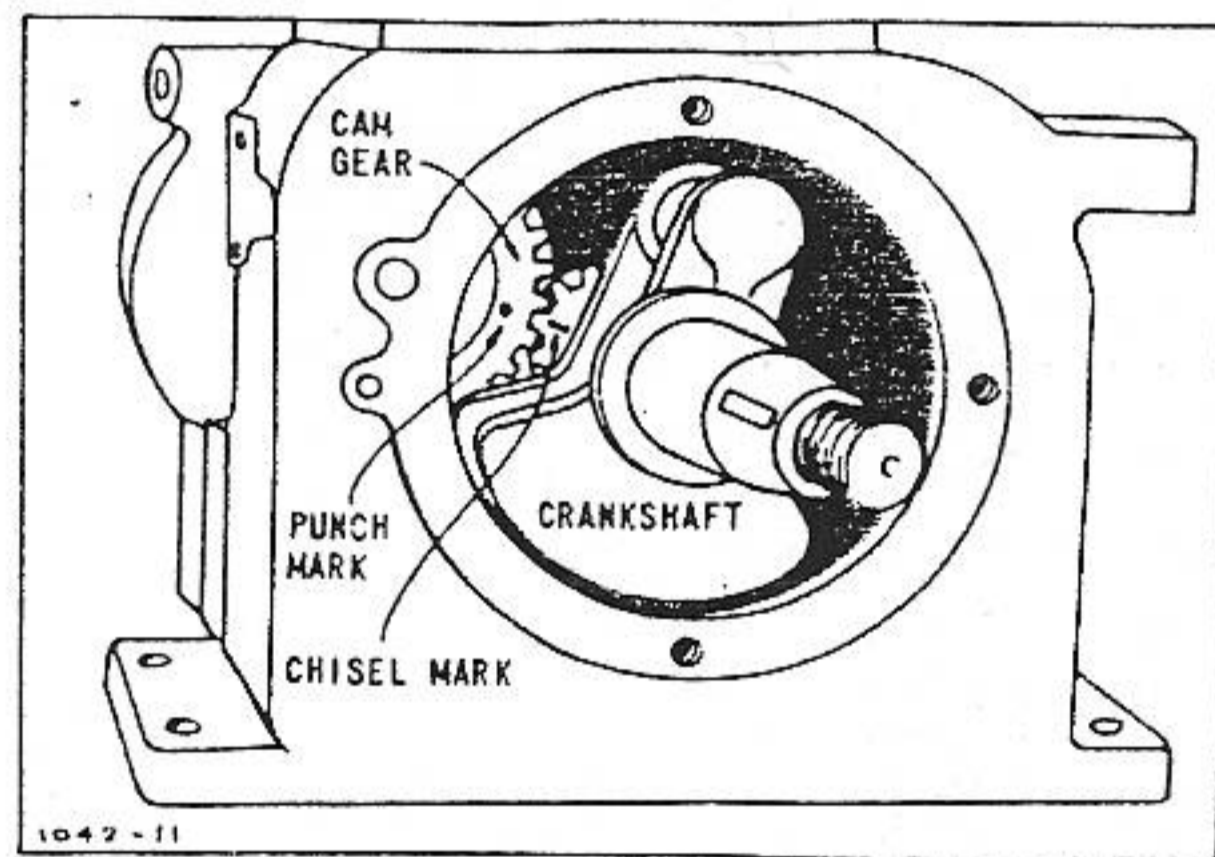


FIG. 128—VALVE TIMING

If the timing mark on any of the gears is on the wrong side, mark the top or opposite end of the timing tooth with chalk. Exceptions as follows:

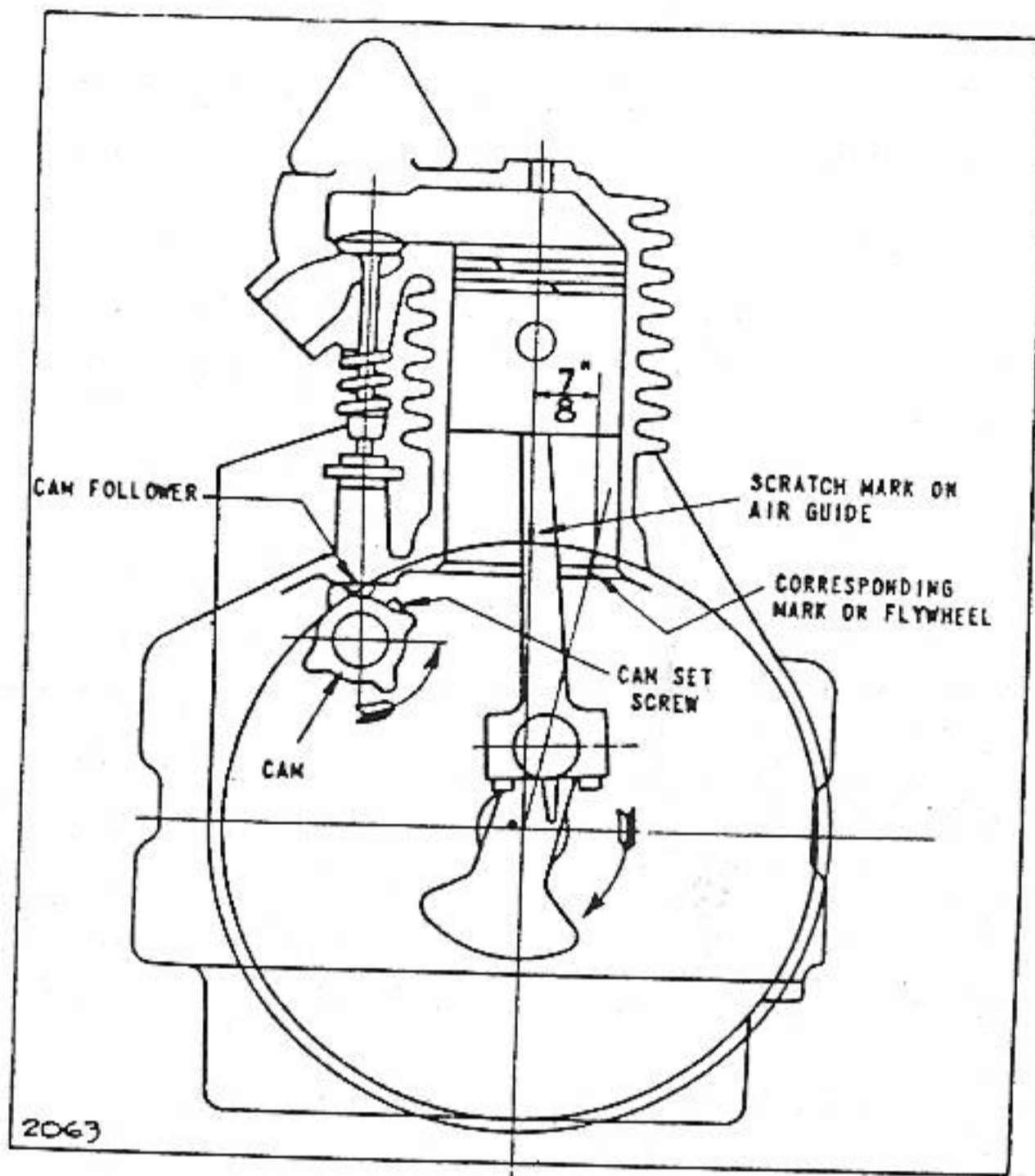


FIG. 129—VALVE TIMING

**Model PB**

With the cam loose on the cam gear shaft and the cylinder in place temporarily, turn the crankshaft so that the piston is at its highest point. Fig. 130. This can easily be found by placing a rod in the spark plug hole on top of the piston. It will rise as the piston rises and the highest point can then be noted. Scratch a mark on the flywheel and a corresponding one on the air guide.

Remove the cylinder. Turn cam (still loose on the gear shaft) until the lobe (which allows the set screw to be tightened through the piston hole) just strikes the cam follower on the left or forward side. Then turn cam slightly to the right to take up the play between the valve stem and valve tappet. See that the mark on the flywheel is on the air guide, then turn the flywheel to the right  $\frac{7}{8}$ " and tighten the set screw on the cam. The engine is then timed correctly.

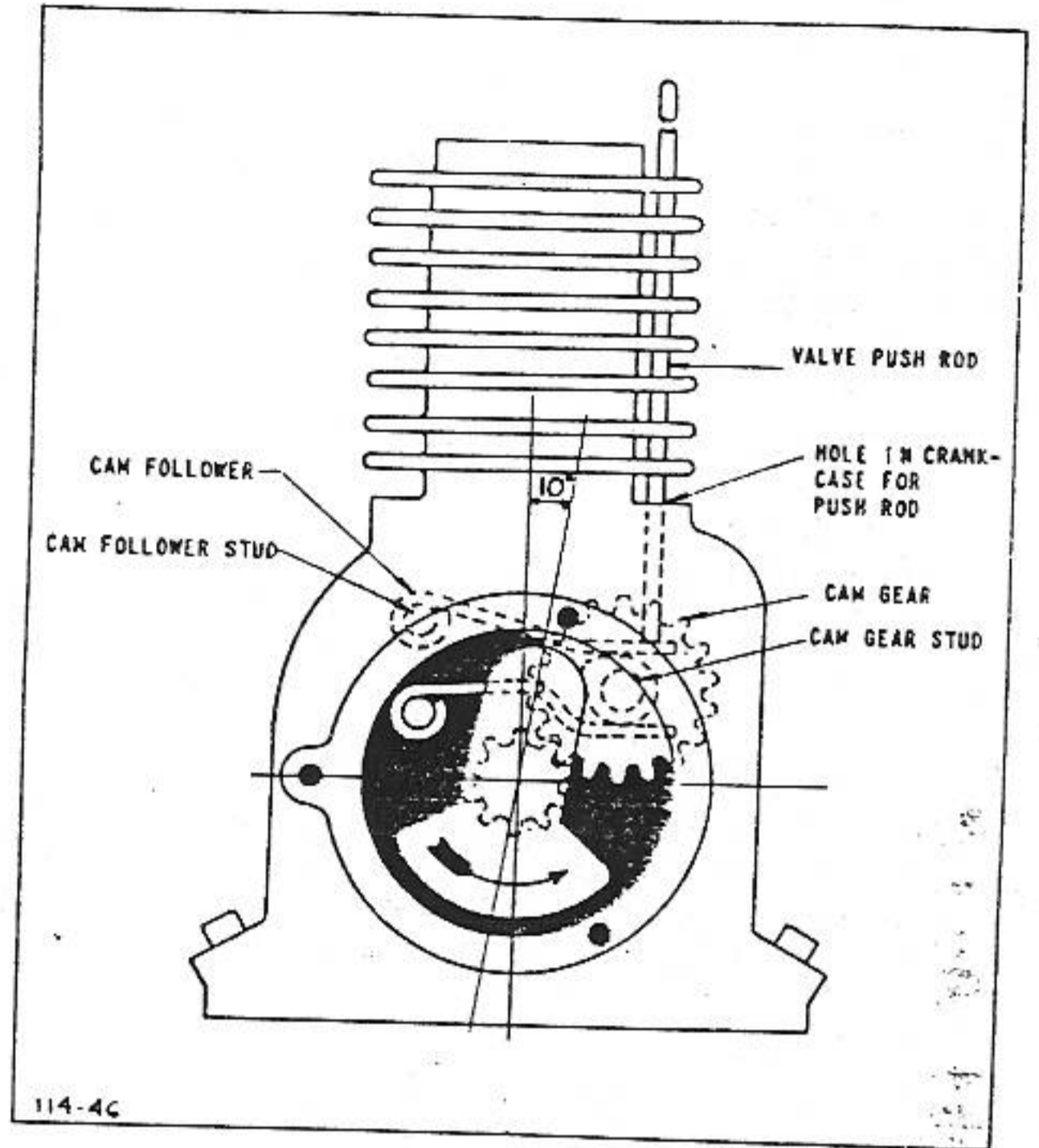


FIG. 130—VALVE TIMING

**Models FH-FI**

To properly time the valves on these models, assemble cam followers in place, insert the exhaust valve push rod through the small hole in top of the crankcase so that the flat end of rod rests on the upper cam follower. Fig. 129. Then place the cam gear on its stud so that the cam lobe is toward the crankcase wall between the two cam followers.

Place finger on top of push rod and press lightly. Be careful not to bend rod and bind against the side of small hole in crankcase. Then rotate the cam gear to the right or clockwise several times until you become familiar with the point where push rod begins to rise. With the cam gear set in this position, insert crankshaft, gear end first and with crankpin  $10^\circ$  to the right of center line and almost in line with top magneto screw hole. Engine will then be in correct time.

de  
as  
til  
on  
to  
nd  
in  
en  
In  
of  
to  
in  
ith  
ver

## PISTONS, PISTON PINS, CONNECTING RODS

The sizes of bearing surfaces of these parts are important and may be compared with sizes shown in Table 15. However, parts apparently in good condition may require checking for size or roundness. A rod bearing .0007" out of round should be rejected.

Always keep in mind the condition of related parts. If, for example, the cylinder is to be rebored, new rings and pistons are required and there is no need to check the old ones.

### To Disassemble

Scrape carbon from upper end of cylinder bore. To remove piston and rod assembly, remove cap from bottom, then push rod and piston up and out. Remove rings by slipping them up over the ring lands, never down over the piston skirt. Fig. 131. Remove pin locks with thin nose pliers. Hold thumb on pin locks when removing to prevent losing them. Push out piston pin. Most pins are a slip fit and can easily be pushed out. However, on some older models the pin is locked in place in one pin hole in the piston. In this case the piston should be heated in boiling water for the removal or assembly of the pin.

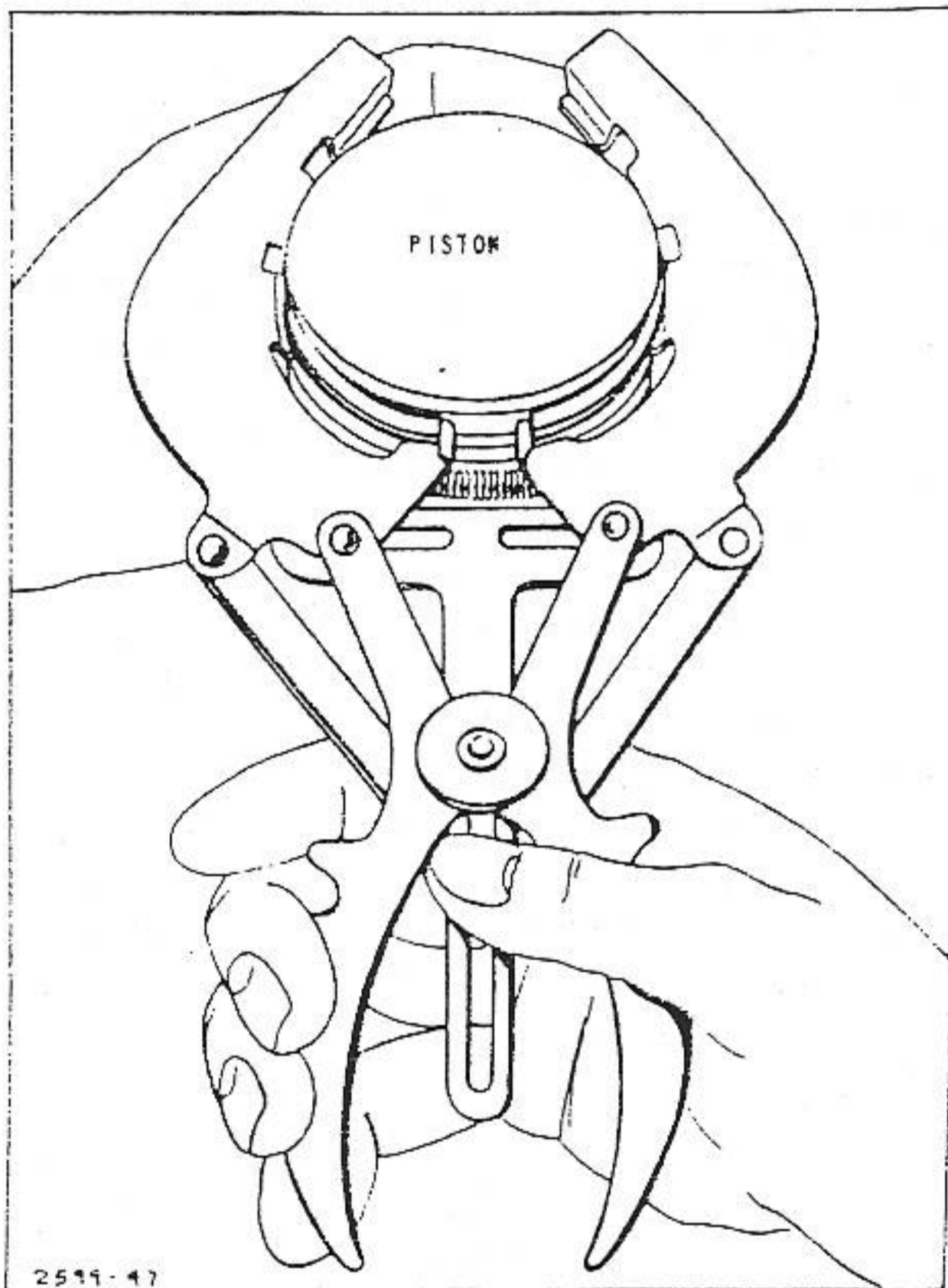


FIG. 131—REMOVING RINGS FROM PISTON

### To Check Rings

Clean carbon from ends or gap of rings and insert them one at a time into the cylinder bore. Push them down a little with the piston to be sure they are square with the bore.

Check gap at ends with feeler gauge. If the gap is .026" or more, when cylinder is within standard bore as shown in Table 19, the ring should be rejected. The gap of new rings should be .007" to .017" on all models. Fig. 132.

TABLE NO. 15 - CONNECTING ROD AND PISTON PIN REJECTION SIZES

| ENGINE MODEL          | CONNECTING ROD |                 | PISTON PIN |
|-----------------------|----------------|-----------------|------------|
|                       | CRANK PIN HOLE | PISTON PIN HOLE |            |
| A-H-L-M-S-T-Y         | .876"          | .56325"         | .561"      |
| B                     | 1.001"         | .6735"          | .6713"     |
| FH-FI-FJ-PB           | .876"          | .56325"         | .561"      |
| I-IBP-WI-WM-WMB WMI-5 | .751"          | .49125"         | .48875"    |
| K-R-W                 | 1.001"         | .736"           | .73375"    |
| N-NS-U-6              | .751"          | .49125"         | .48875"    |
| Q                     | 1.001"         | .616"           | .61375"    |
| Z-ZZ                  | 1.001"         | .736"           | .7338"     |
| 8                     | .751"          | .49125"         | .48875"    |
| 9                     | .876"          | .56325"         | .561"      |
| 14                    | 1.001"         | .6735"          | .6713"     |
| 23                    | 1.189"         | .736"           | .7338"     |

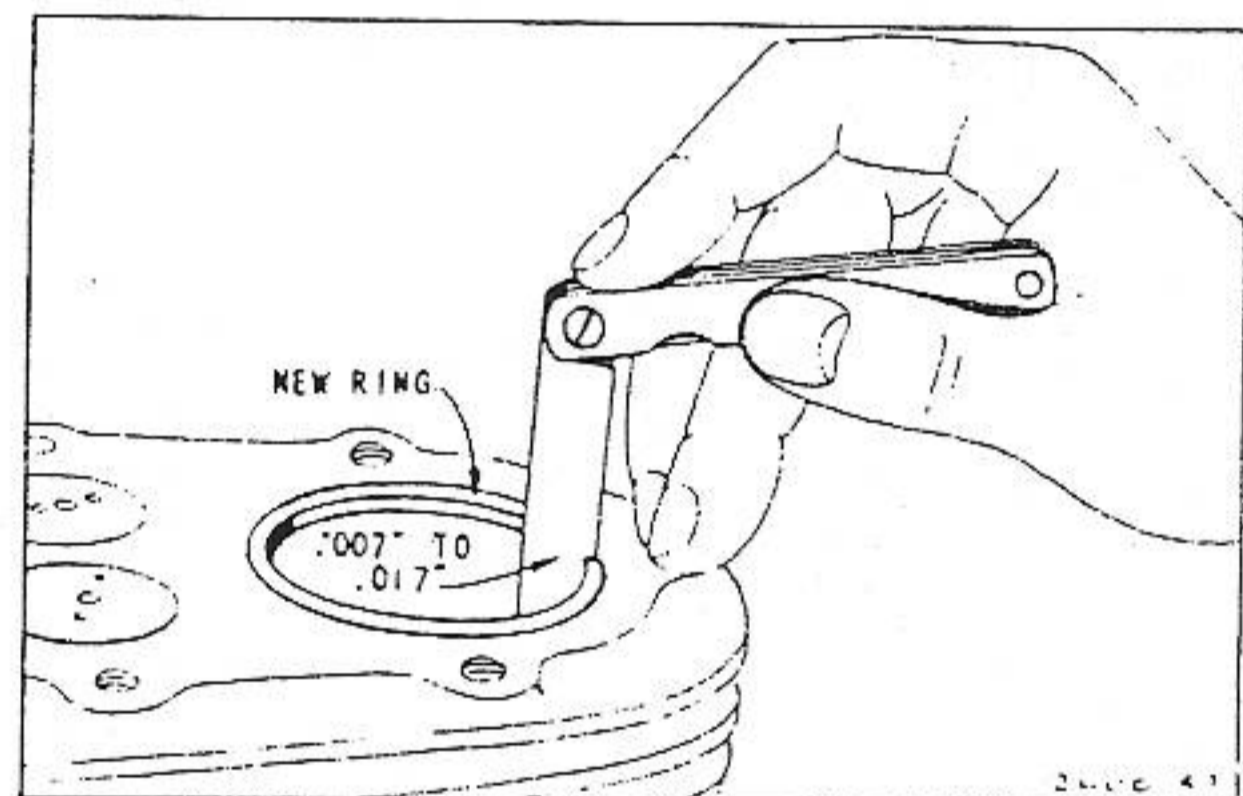


FIG. 132—CHECKING RING GAP

### To Check Piston for Wear

If the piston shows no visible signs of wear, scoring or scuffing, and the cylinder is not to be rebored, the piston should be checked. To do so, clean carbon from the top ring groove. Place a new ring in the top ring groove. Check the remaining space in the groove with a feeler gauge.

If a .005" feeler can be inserted on 2" bore and Model 8 engines and .007" feeler on Models A-B-FJ-H-L-M-S-T-ZZ-9-14-23, the piston is worn and should be replaced. Fig. 133. Some pistons have four grooves. The top groove in this case is not used. It is called a Heat Insulating Groove or Heat Dam.

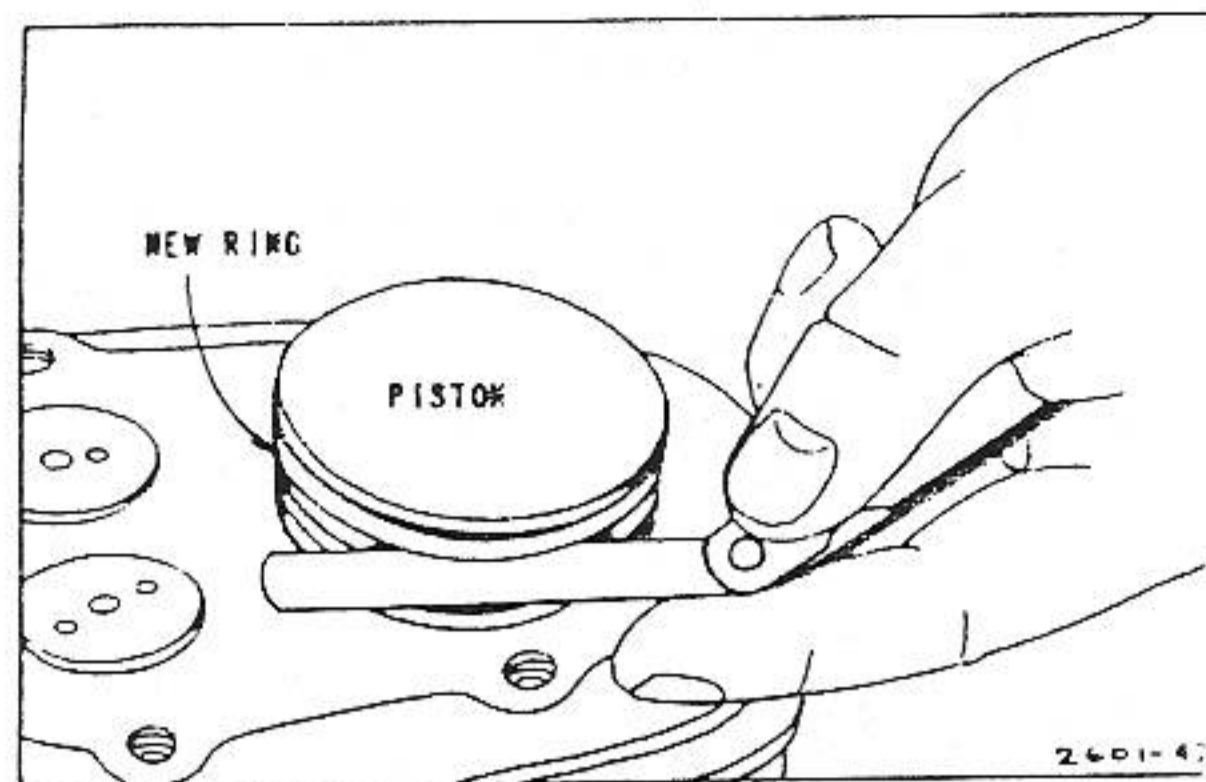


FIG. 133—CHECKING RING GROOVE

**To Check Pin Holes in Piston**

The pin holes can be measured if so desired with an inside micrometer or pair of calipers. Table 15. However, since testing ring groove wear is most important, it is seldom necessary to check the pin holes.

**To Check Piston Pin**

Use an accurate micrometer and take readings at several points to find point of greatest wear. Table 15. A pin .0005" out of round should be rejected.

**To Check Connecting Rod**

If the crankpin bearing is scored the rod must be discarded. Scoring is usually caused by dirty or insufficient oil. The desired clearance between rod bearing and crankpin is .0015". This is to allow for oil but should in no case be more than .0045".

If the piston pin hole in rod or piston are worn, a .001" oversize piston pin may be used. If parts do not come up at .005" oversize, they should be discarded. Steel connecting rods have a removable bushing for the piston pin. This can be removed and a new one pressed in and reamed to size.

Do not attempt to repair the crankpin bearing in a connecting rod. If it is worn or scored the rod should be replaced.

**To Assemble**

There are several things to keep in mind while assembling the rod, piston, piston pin and rings to each other while installing them in the engine. These operations are quite simple but may cause damage if not done properly.

1. Arrangement of rings on piston.
2. Position of piston in cylinder.
3. Position of rod in crankcase.
4. Alignment of rod and piston.
5. Proper installation into engine.

The position of the piston in the cylinder is determined by an "X" mark inside the piston on the pin boss. Fig. 134.

The "X" side should go toward the magneto side of the engine. If the piston has no "X" mark it may be installed either way. The position of the rod in the crankcase is determined by the clearance flat, the oil hole, or the assembly marks. It is important that the rod be properly installed in order to insure clearance and sufficient lubrication. Refer to Fig. 135 for proper installation of various

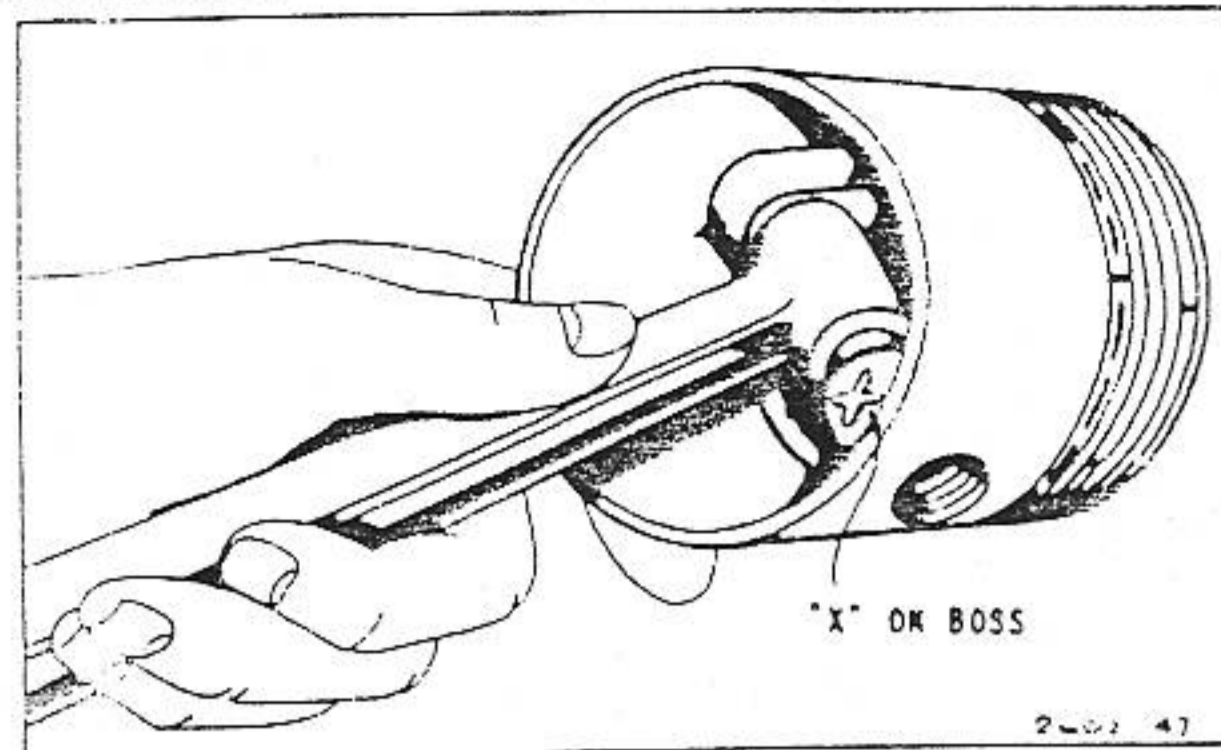


FIG. 134—ASSEMBLING CONNECTING ROD

rods. The side of the rod which is shown is the magneto side. The rod and the piston must be assembled with the magneto sides in line.

NOTE: Use a thin nose pliers to assemble pin lock rings. Be sure the locks are set firmly in the grooves.

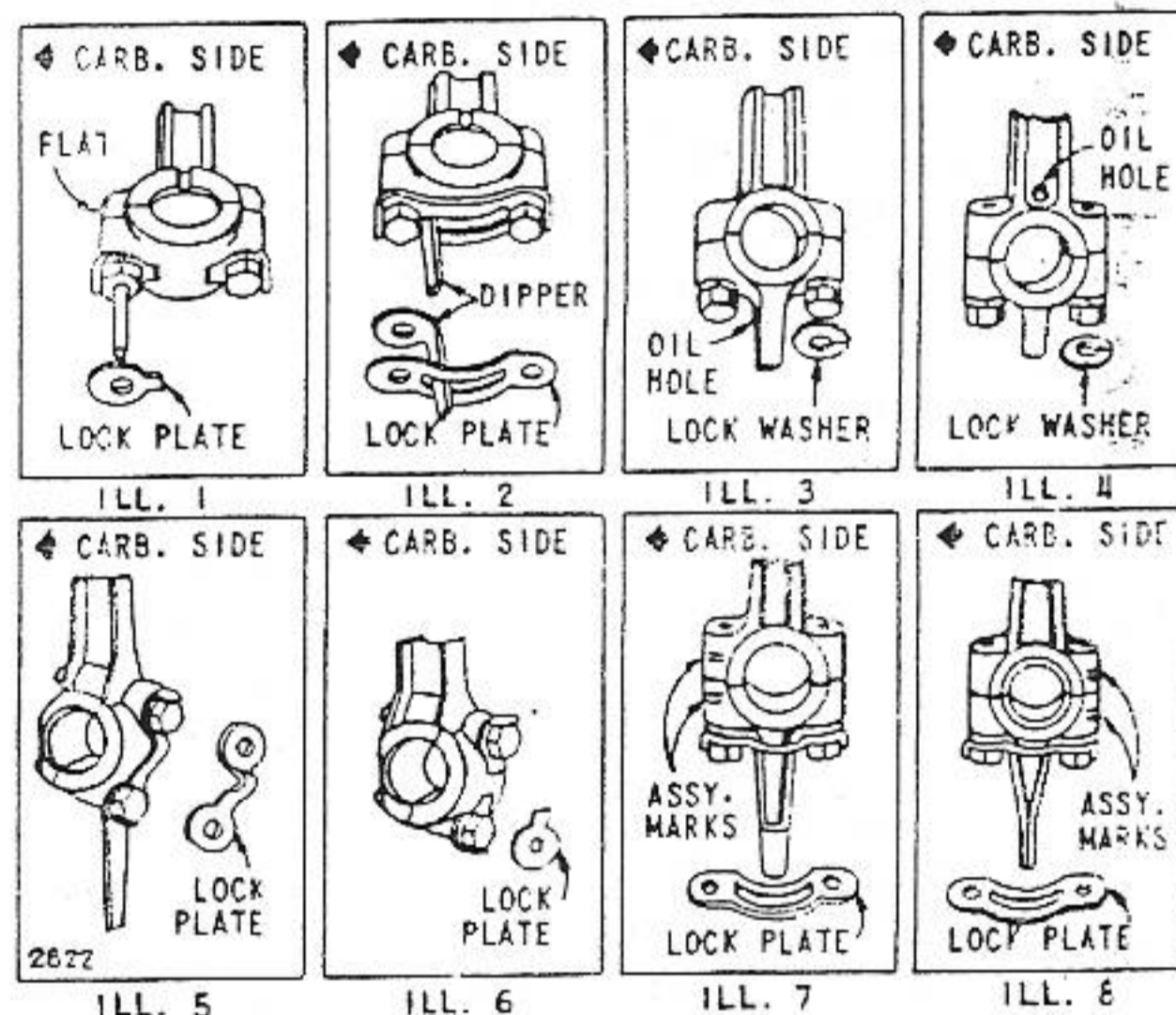


FIG. 135—CONNECTING ROD INSTALLATIONS

**To Align Rod and Piston**

In order for the piston and rings to function properly they must be in alignment with the cylinder bore and square with the crankshaft. Use Piston Alignment and Squariness Gauge, part No. 66629-T5 to test for squareness and twist.

**To Test for Squareness**

Select proper alignment plug (Table 16) and assemble crankpin end of rod to plug. Fig. 136. Tighten cap screws so rod will fit securely on plug. Move piston and rod until piston is in center of aligning plate and note how piston skirt touches plate. Reverse rod on alignment plug to check opposite side of piston skirt against plate. If rod and piston are square the piston skirt, from bottom of skirt to bottom of oil ring groove, will touch the alignment plate evenly on each side.

NOTE: On some pistons the skirt is ground tapered. In such cases there will be a slight space at oil ring end of skirt. This space must be equal on both sides in order to have the piston and rod in perfect alignment. If skirt does not touch plate evenly, bend rod by tapping with palm of hand as shown in Fig. 136, Ill. A or B whichever is indicated.

TABLE 16 - ROD ALIGNING PLUGS

| ENGINE MODEL               | USE PLUG NO.               |
|----------------------------|----------------------------|
| A-FH-FI-H-L-M-PB-S-T-Y     | <sup>2</sup><br>66629-T5-2 |
| B-K-Q-R-W-Z-ZZ             | <sup>3</sup><br>66629-T5-3 |
| I-IBP-N-NS-U-WI-WM-WMB-WMI | <sup>4</sup><br>66629-T5-4 |
| 5-6-8                      | <sup>4</sup><br>66629-T5-4 |
| 9                          | <sup>2</sup><br>66629-T5-2 |
| 14                         | <sup>3</sup><br>66629-T5-3 |
| 23                         | <sup>23</sup><br>21875-T5  |

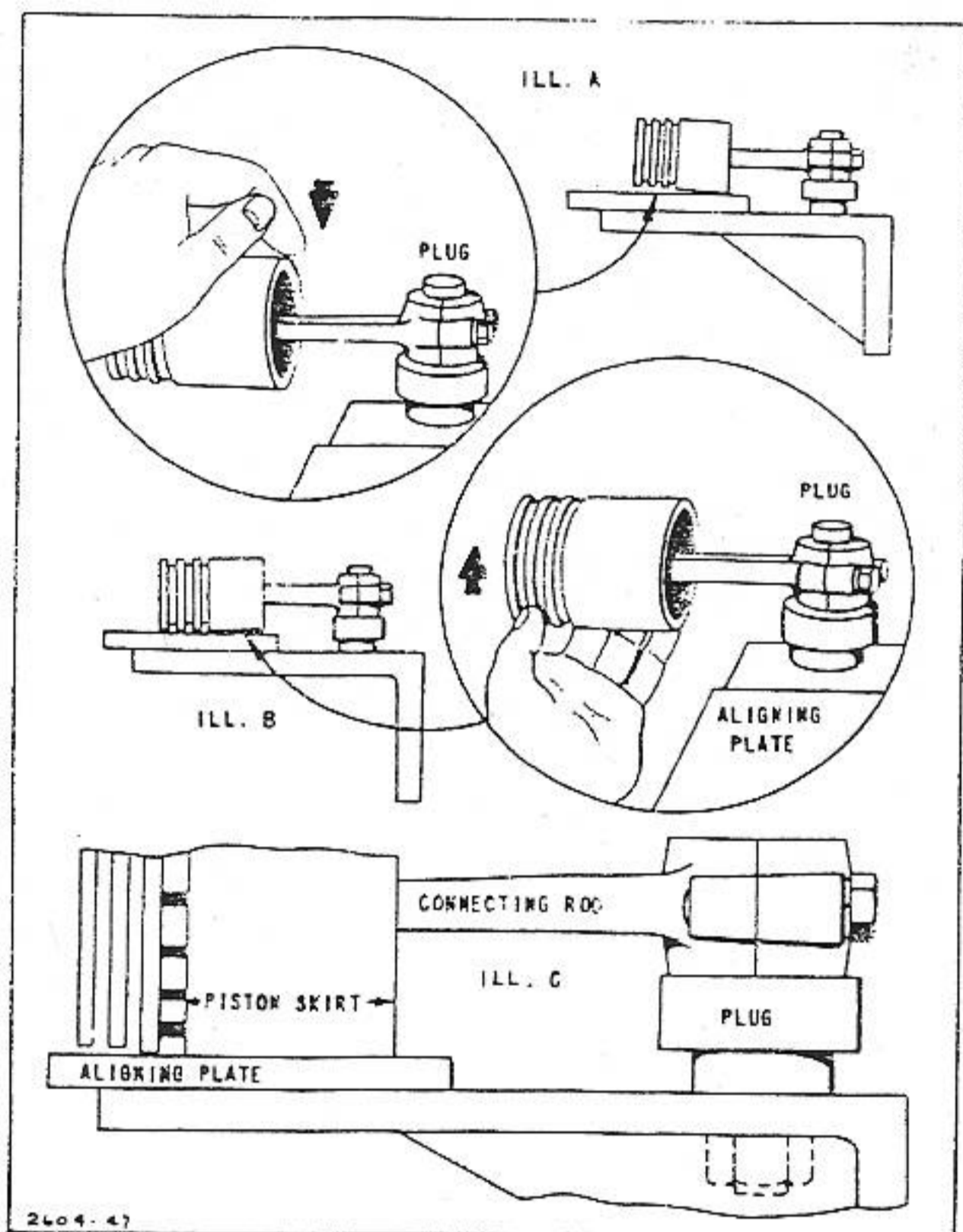


FIG. 136—ALIGNING ROD AND PISTON

**To Test for Twist**

Place piston in position shown in Fig. 137, Ill. A and see if piston touches alignment plate evenly.

Place piston in position shown in Ill. B and see if piston skirt touches alignment plate evenly. If skirt does not touch evenly, swing piston away from plate and twist rod with adjustable wrench as shown in Fig. 137, Ill. B.

Replace rod against plate to recheck. If rod is properly aligned, the piston skirt will touch evenly in all directions as shown in Fig. 137, Ill. C. Remember that tapered pistons will have a small space at the ring end of skirt in all positions. The Piston and Squareness Gauge should be so placed that it will be between the operator and a window or light. This will make gauging the space between aligning plate and piston skirt much simpler.

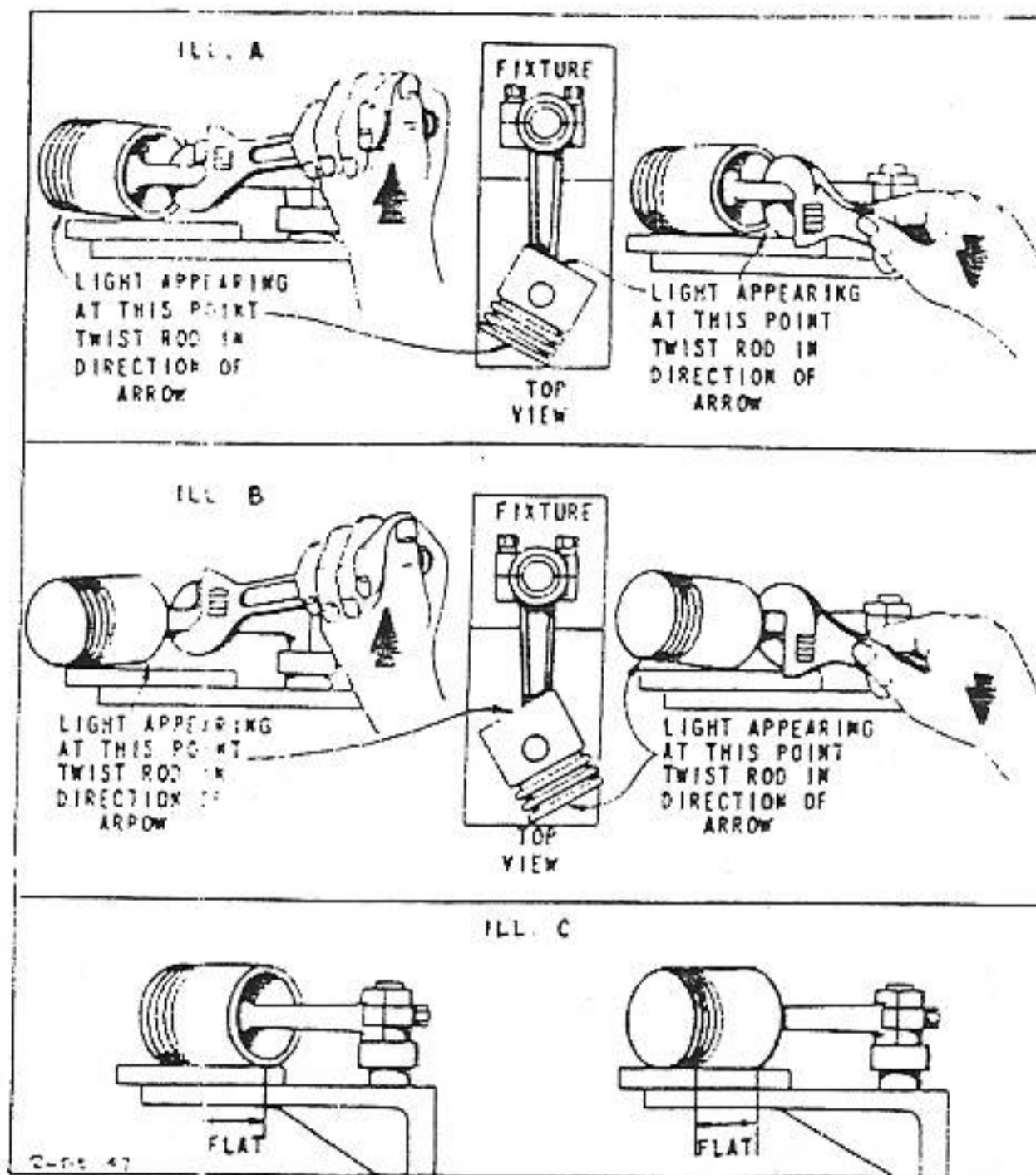


FIG. 137—SQUARING PISTON & ROD

**To Assemble Rings to Piston**

There are usually three different rings to a piston: (1) top ring, (2) center compression or scraper ring and (3) oil ring.

In Fig. 138 are shown the various rings and the proper position of each. Note especially the center compression ring. The scraper groove should always be down toward the piston skirt.

Be sure the oil return holes are clean and carbon is removed from all grooves, then assemble rings — oil ring first.

NOTE: Be sure to use rings called for in Parts Manual for 5 digit type number Model A engines. The ring grooves in old style pistons are not deep enough and require a thinner ring. See Parts Manual. However, if the old style piston has been replaced by a new style piston, the new style ring should be used. Be sure to use the proper rings on Models 14-23-B-ZZ, as both 1/8" and 3/32" rings are used.

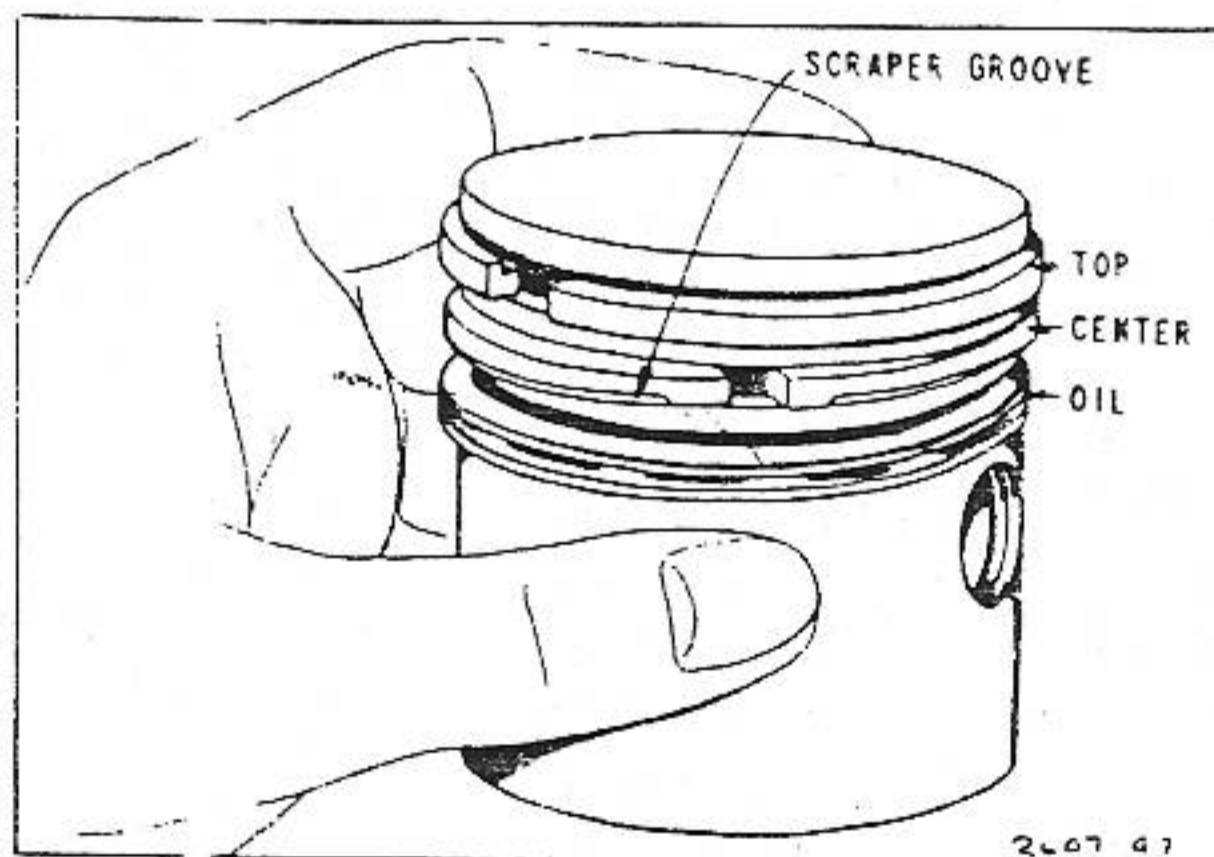


FIG. 138—POSITION OF RINGS

TABLE 17 - CONNECTING ROD  
CAP SCREW TORQUE

| MODEL       | MIN INCH LBS. | MAX. INCH LBS. |
|-------------|---------------|----------------|
| A-9         | 130           | 150            |
| B-14        | 175           | 200            |
| All 2" bore | 90            | 110            |
| 8           | 90            | 110            |
| ZZ          | 175           | 200            |
| 23          | 175           | 200            |

**To Install Piston and Rod in Cylinder**

Remove rod cap from rod and make sure all bearing surfaces are perfectly clean. Oil the rings, piston skirt, piston pin and rod bearings. Stagger the ring gaps around piston and insert rod and piston into cylinder with oil hole, clearance flat and assembly marks in the proper position. Fig. 135.

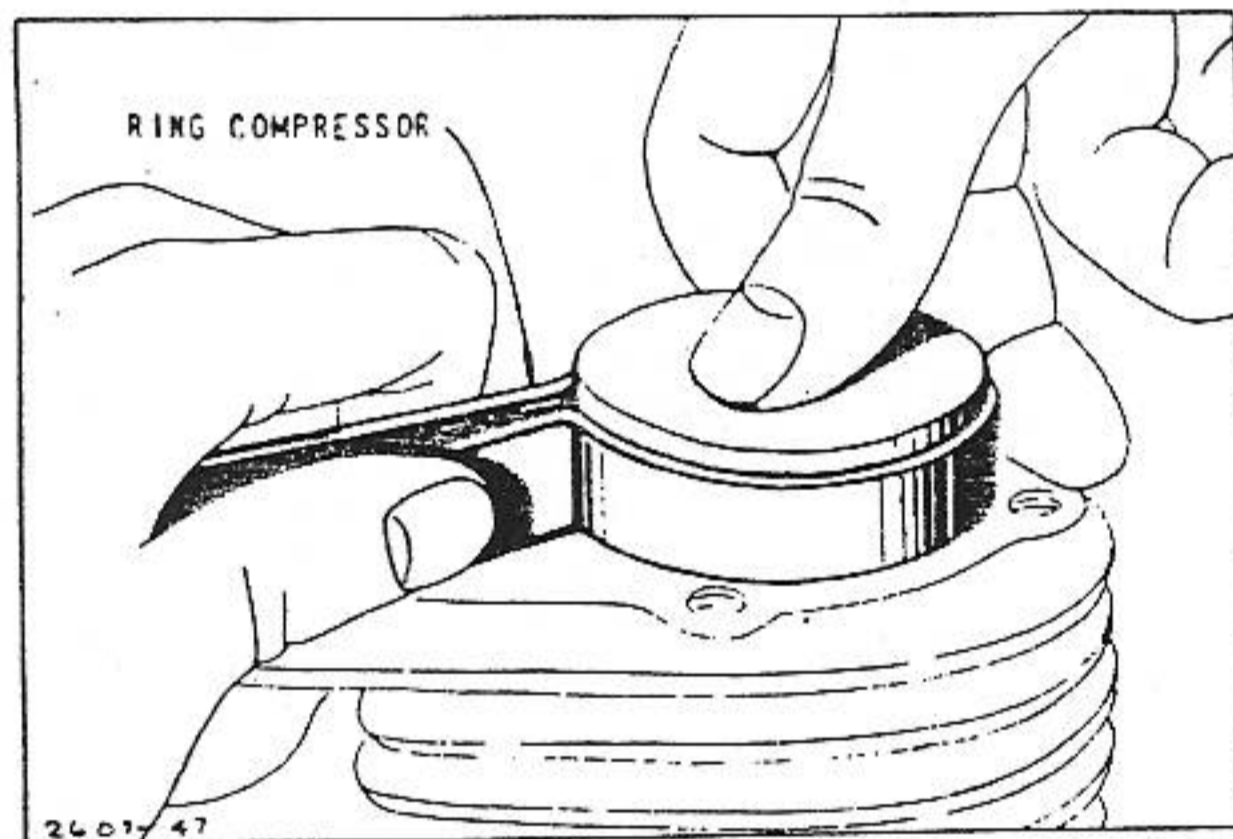


FIG. 139—INSERTING PISTON AND RINGS

Compress rings with ring compressor and push piston down into cylinder. Fig. 139. If piston does not go down easily, raise it up and find the reason. Never attempt to force piston down, as broken rings, scored cylinder or nicked bearings may result.

After piston is entirely in the cylinder, invert engine or lay it on its side. Pull rod down and fit rod bearing to crankpin. Assemble cap to rod taking care that assembly marks come together. Tighten cap screws securely to the torque shown in Table 17. Revolve crankshaft at least two revolutions. If rod strikes cam, assembly instructions have not been followed or the engine is out of time. If crankshaft operates freely, bend locking plate against screw heads as shown in Fig. 135. See Fig. 140 for general view of rod assembly with oil dipper.

BE SURE ALL PARTS ARE CLEAN WHEN ASSEMBLED. A TINY BIT OF DIRT WILL RUIN A BEARING IN A FEW REVOLUTIONS.

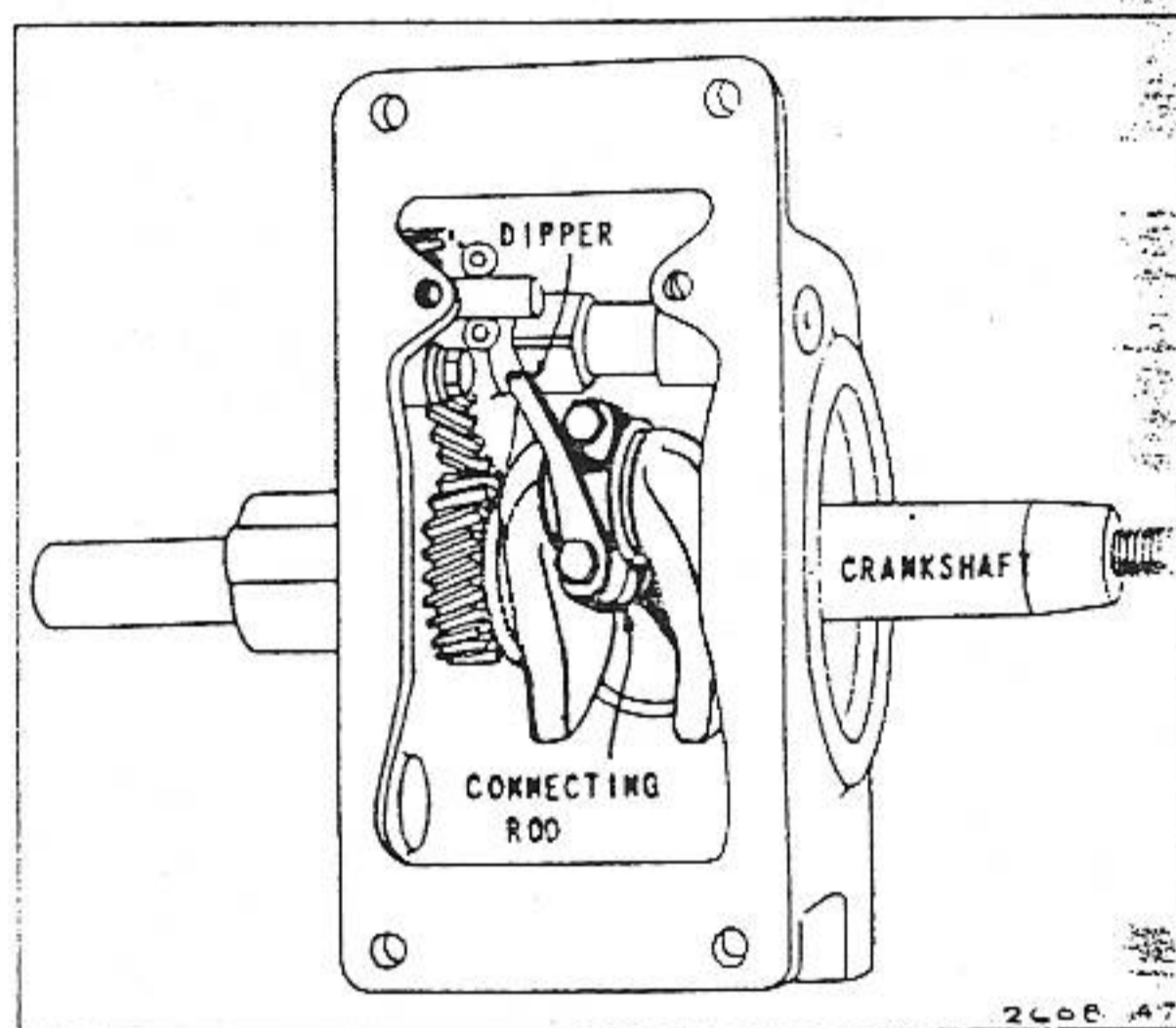


FIG. 140—GENERAL VIEW OF ROD ASSEMBLY

## CRANKSHAFTS, CAM GEARS

The crankshaft and cam gear should always be removed from the crankcase with utmost care to prevent damage to gear and bearing surfaces.

### To Remove Crankshaft Models B-K-Z-ZZ-9-14-23

Remove crankcase cover. Revolve crankshaft until crankpin is pointing upward toward the breather at the rear of the engine at approximately a 45° angle. Then pull crankshaft out from drive side twisting it slightly if necessary. Fig. 141. On Models 9-14-23 with ball bearings, both crankcase cover and bearing support should be removed.

### All Other Models With Ball Bearings on Drive Side

Remove magneto. Drive out cam gear shaft. Fig. 143. Push cam gear forward into recess at front of engine. Fig. 142. Then draw crankshaft from magneto side. Double thrust engines have cap screws inside the crankcase holding the bearing in place. These must be removed before crankshaft can be withdrawn.

### All Models With Bushings on Drive Side

Remove magneto and withdraw crankshaft from magneto side.

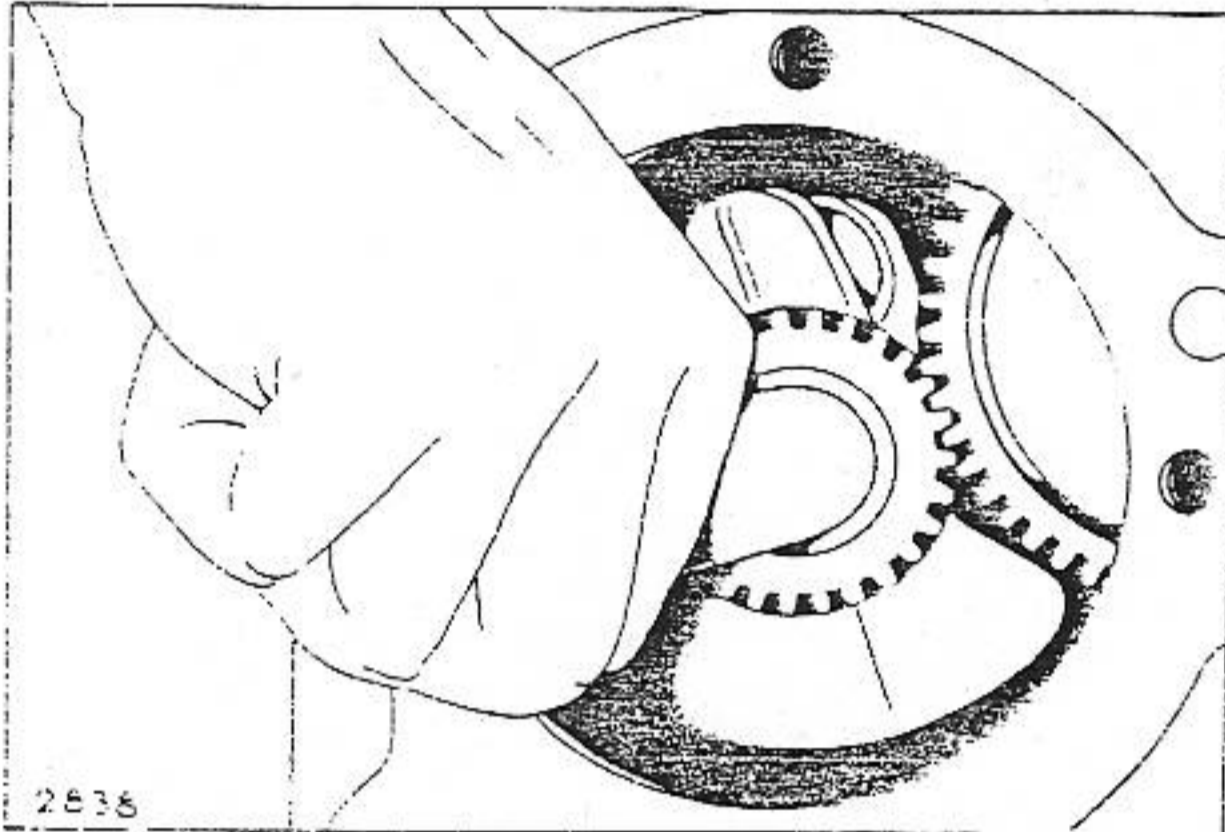


FIG. 141—REMOVE OR ASSEMBLE CRANKSHAFT

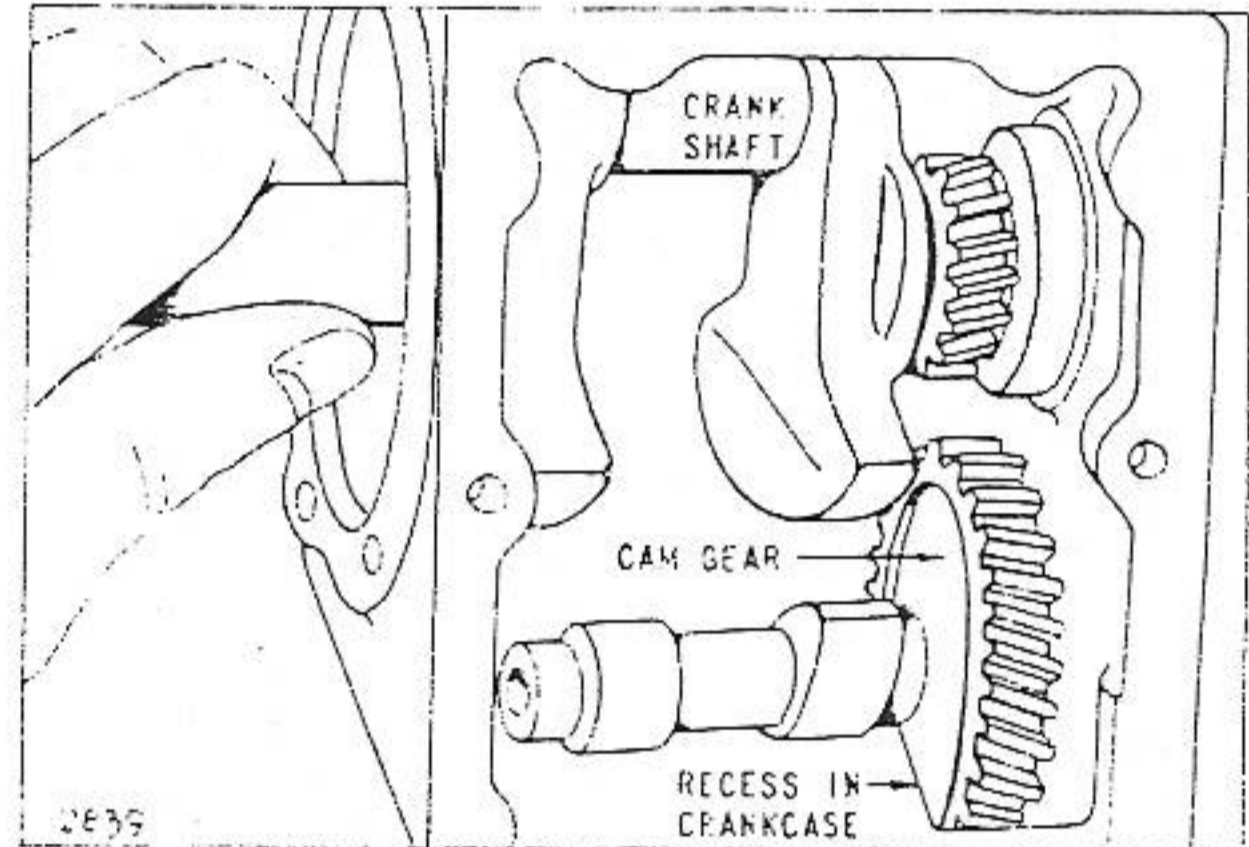


FIG. 142—REMOVE OR ASSEMBLE CRANKSHAFT

TABLE NO. 18 - REJECTION SIZES

| ENGINE MODEL           | REPLACE AT THESE OR SMALLER SIZES |               |          |          |                        |
|------------------------|-----------------------------------|---------------|----------|----------|------------------------|
|                        | CRANKSHAFT                        |               |          | CAMSHAFT | CAM GEAR LOBE          |
|                        | Mag. Journal                      | Drive Journal | Crankpin |          |                        |
| A                      | 1.092                             | .992          | .872     | .37185   | 1.187                  |
| AMT                    | 1.092                             | .9827         | .872     | .37185   | 1.187                  |
| AHP-AP                 | 1.092                             | .9832         | .872     | .37185   | 1.187                  |
| B                      | 1.092                             | 1.122         | .997     | .49675   | 1.429                  |
| BM                     | 1.092                             | 1.1795        | .997     | .49675   | 1.429                  |
| BP                     | 1.092                             | 1.803         | .997     | .49675   | 1.429                  |
| FH-FI                  | .967                              | .872          | .872     | .497     | .971                   |
| FJ-S-T                 | .967                              | .872          | .872     | .37185   | 1.081                  |
| H-Y                    | 1.092                             | .992          | .872     | .37185   | .988                   |
| I-N-NS-U-WI-WM-WMB-WMI | .8736                             | .8736         | .747     | .37185   | .867                   |
| IBP-IP-IP              | .8736                             | .7863         | .747     | .37185   | .867                   |
| K                      | 1.092                             | 1.122         | .997     | .49675   | 1.396                  |
| KM-Z                   | 1.092                             | 1.1803        | .997     | .49675   | 1.396                  |
| L-M                    | .967                              | .872          | .871     | .37185   | .987                   |
| PB                     | .967                              | .997          | .8715    | .747     | 2.035                  |
| Q                      | .967                              | 1.122         | .997     | .49675   | 1.272                  |
| R-W                    | .967                              | 1.122         | .997     | .49675   | 1.396                  |
| ZM                     | 1.092                             | 1.1795        | .997     | .49675   | 1.396                  |
| ZZ                     | 1.092                             | 1.1603        | .997     | .49675   | Ex. 1.444<br>In. 1.434 |
| 5-6-8                  | .8736                             | .8736         | .747     | .37185   | .867                   |
| 9                      | .9832                             | .9832         | .8724    | .37185   | 1.134                  |
| 14                     | 1.180                             | 1.180         | .9974    | .49675   | 1.165                  |
| 23                     | 1.3769                            | 1.3769        | 1.1854   | .49675   | 1.194                  |

**To Remove Cam Gear**

Use a long thin punch to drive out the cam shaft. Do not burr or rivet end of shaft while doing so. Hold cam gear while withdrawing punch so gear does not fall and nick. Always drive camshaft out from drive side toward magneto side. Fig. 143.

**Model PB**

Loosen set screw on valve cam inside the crankcase. Remove gear cover. Pull out cam gear and shaft. A burr sometimes forms on the shaft from set screw. If so, set crankcase on side and with two screw drivers gently pry cam gear upward until it is loose.

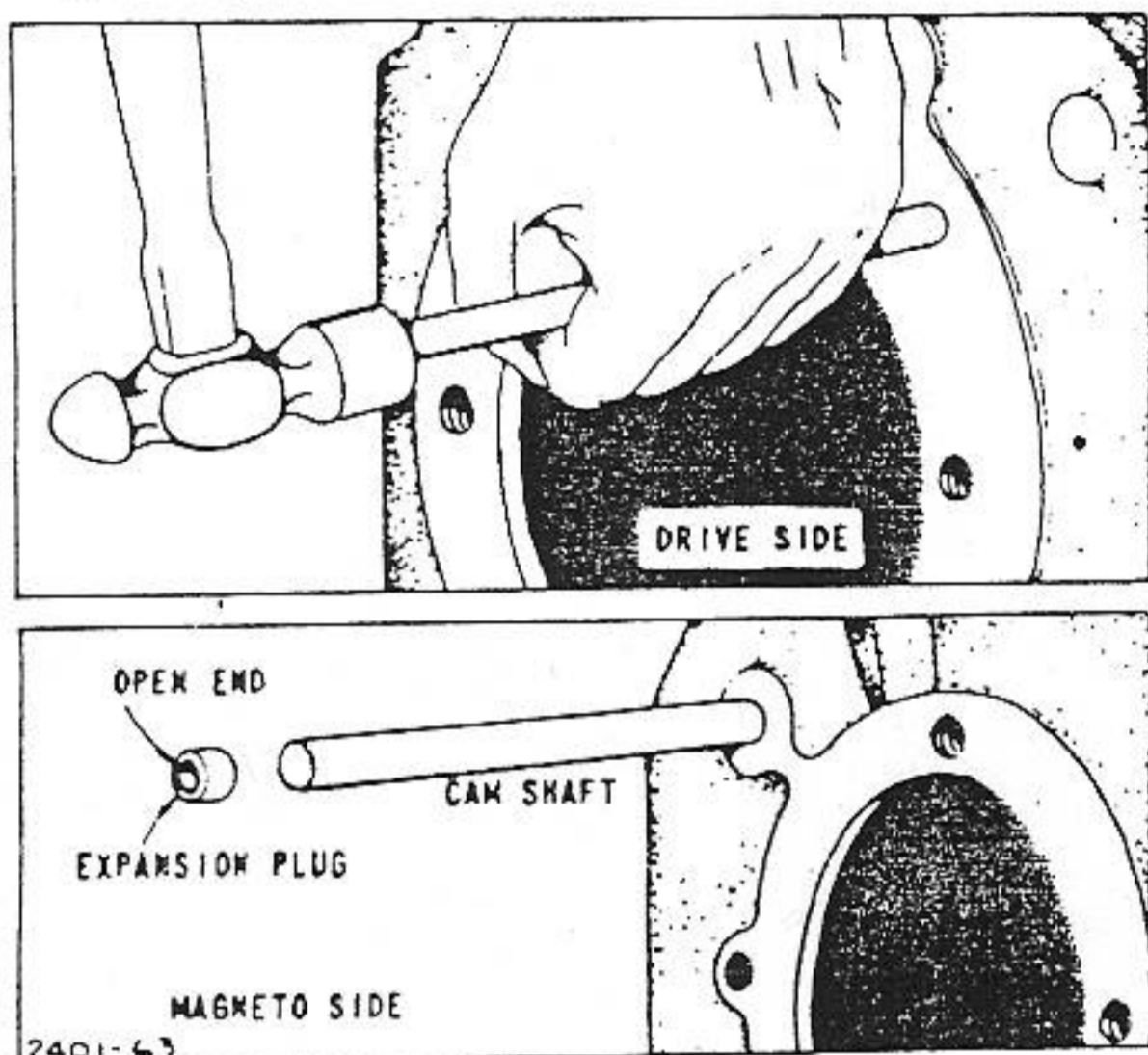


FIG. 143—REMOVE CAMSHAFT

**Models FH-FI**

Slide cam gear off cam shaft from inside crankcase. DO NOT drive out cam shaft.

**To Check Crankshaft and Cam Gear**

Table No. 18 shows the rejection sizes of the various points where wear occurs on the crankshaft and cam gear. Discard parts if worn smaller than the size shown. Check the gear teeth very carefully.

Keyways should be checked with new keys to be sure they are not worn and spread. Remove burrs from keyway edges to prevent scratching the bearings. Figs. 144 and 145 show the various points to be checked on the crankshaft and cam gear.

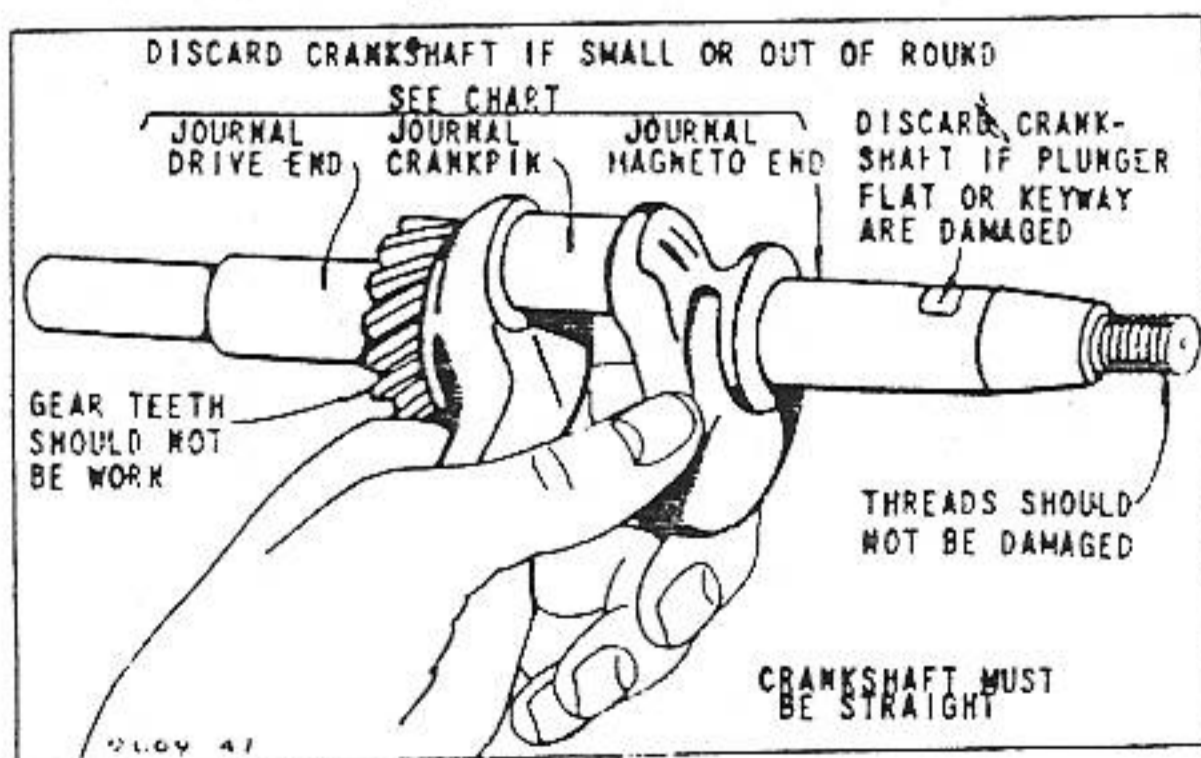
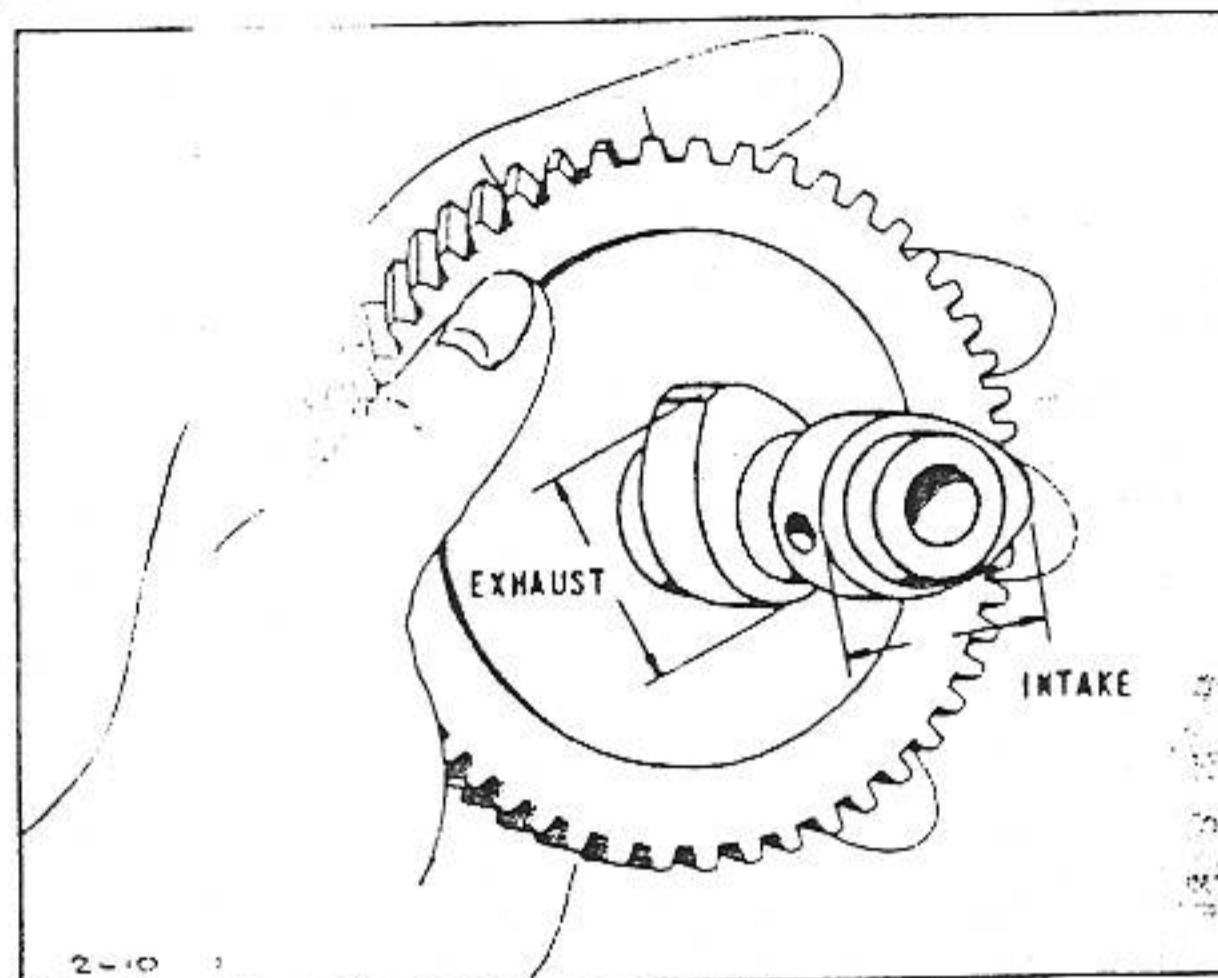


FIG. 144—CRANKSHAFT CHECK POINTS

**Model FI**

The first Model FI engines had a cam gear made of cast iron. This gear may be identified by three diagonal holes drilled into the gear lobe. When you receive an engine with this gear, ALWAYS replace it with a heat treated gear, Part No. 2401-63.



—CAM GEAR CHECK POINTS

**To Reinstall Cam Gear and Crankshaft**

Be sure to place cam followers in the crankcase before replacing cam gear. Slide camshaft through hole in crankcase on magneto side and through gear until it touches crankcase on drive side. (If shaft does not go in easily, check for burrs or nicks.) Then press camshaft in until flush with inside of crankcase on drive side. Install expansion plug with shellac or gasket seal. Fig. 143.

NOTE: On engine Models AP-NP-IP-8B with ball bearing on crankshaft, the crankshaft must be installed before camshaft is driven in. Place cam gear in recess, insert crankshaft and pull cam gear back until gear teeth engage and timing marks match. Then install camshaft. The crankshaft is installed the same as it was removed. Be sure to engage the gears with timing marks matching. Fig. 145. Use a piece of shim stock as shown in Fig. 146.

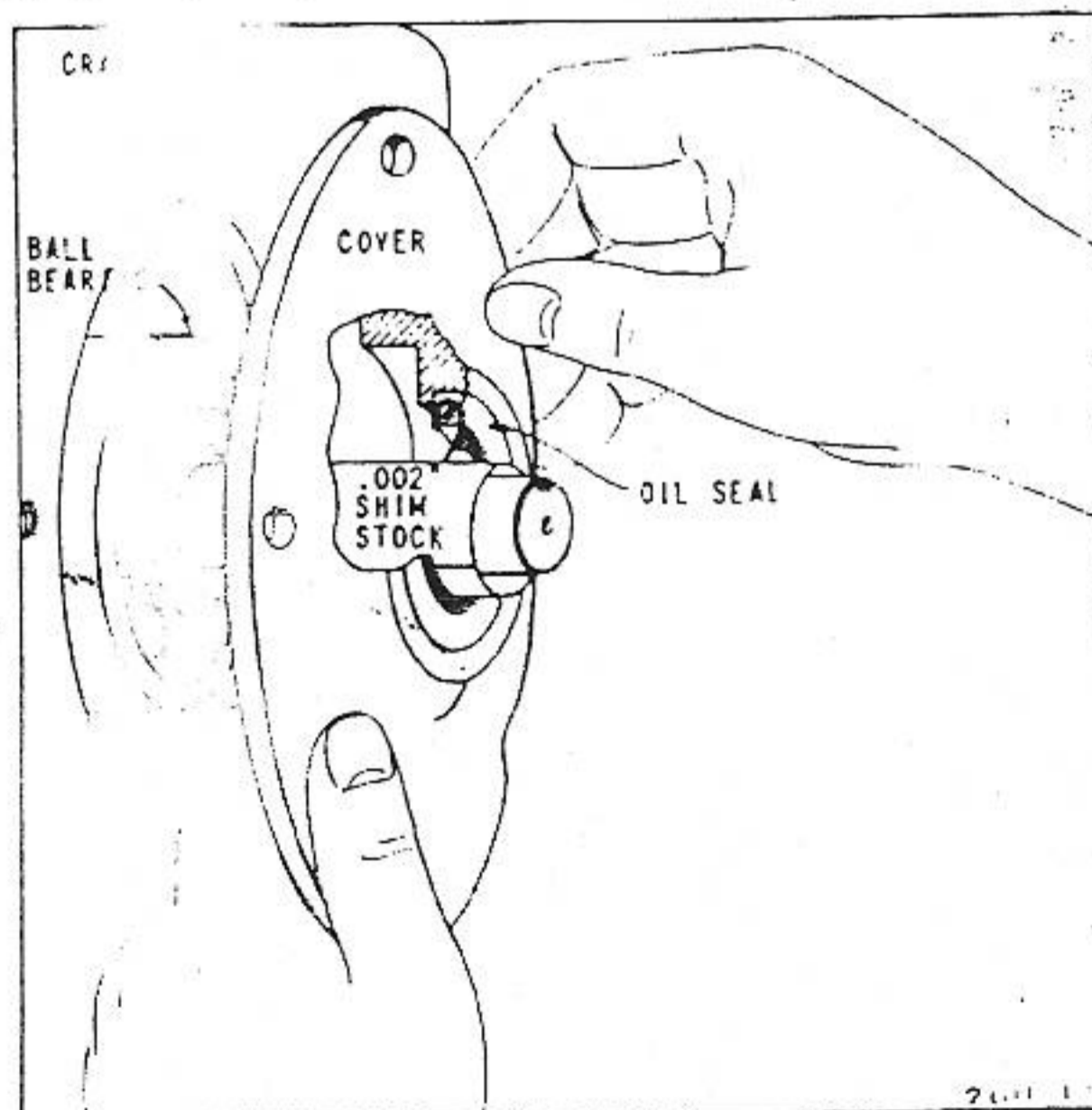


FIG. 146—PROTECTING OIL SEAL

(See Following Page.)

to prevent damage to oil seal or oil seal. For full instructions on timing. There should always be a small amount between cam gear and crankshaft gear.

**Model PB**

Assemble cam, cam gear and crankshaft. Assemble the thrust washer between cam and crankshaft.

Place Timing Gauge No. MPJ between cam and crankpin as shown in Fig. 147. Use a wedge 10" to hold crankshaft in place. Use socket wrench and 13A33-T2\* to tighten the set screw. A piece of 1/8" round cold rolled steel is used as a pin between the two ends of the wrenches, and the set screw is tightened until this 1/8" cold rolled steel is held in place. Allow end play of about .005" on cam before tightening set screw.

\*No longer available. If not in kit, use 1/2" hexagon socket and T handle.

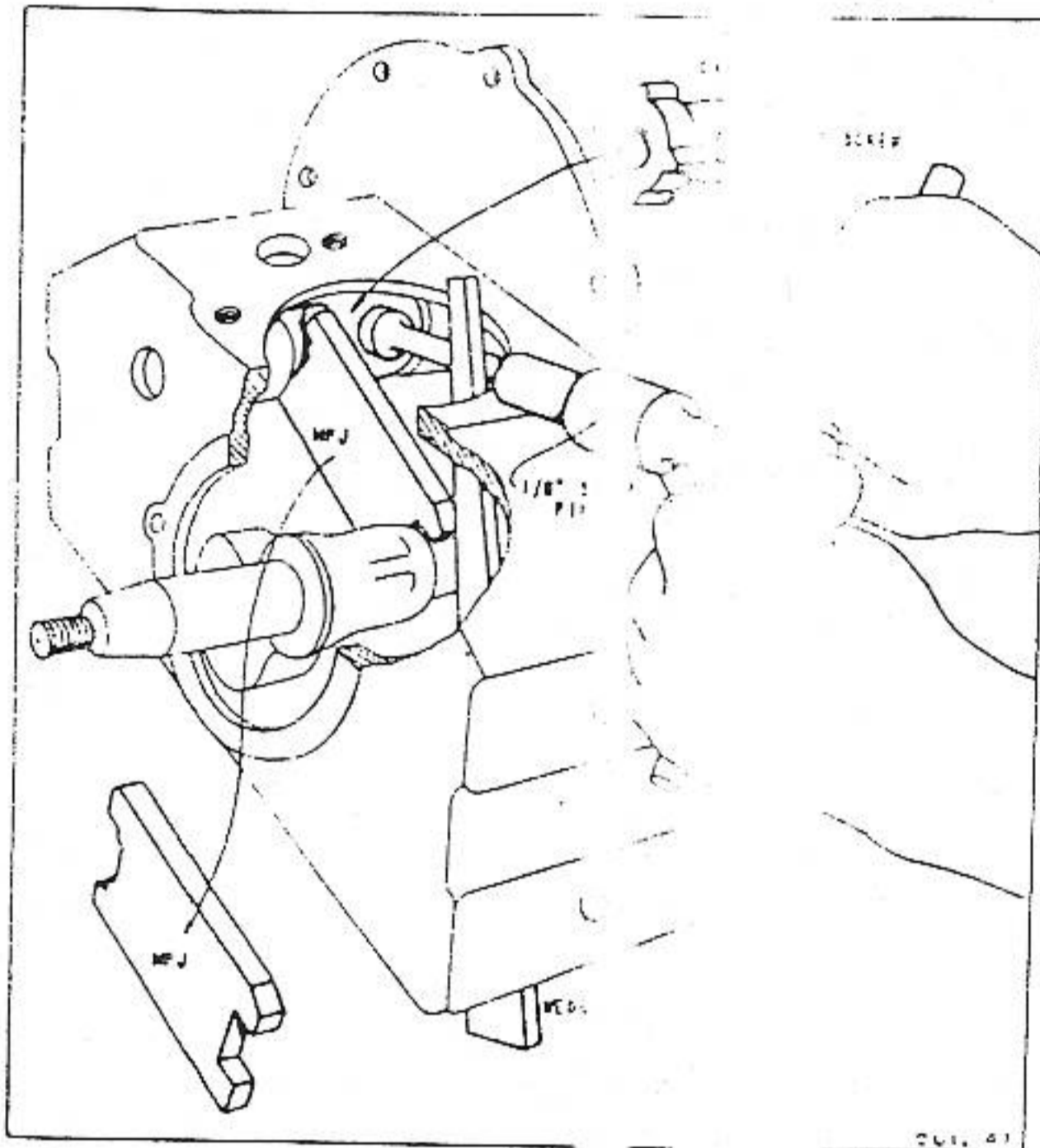


FIG. 147—ASSEMBLE CAM GEAR MODEL PB

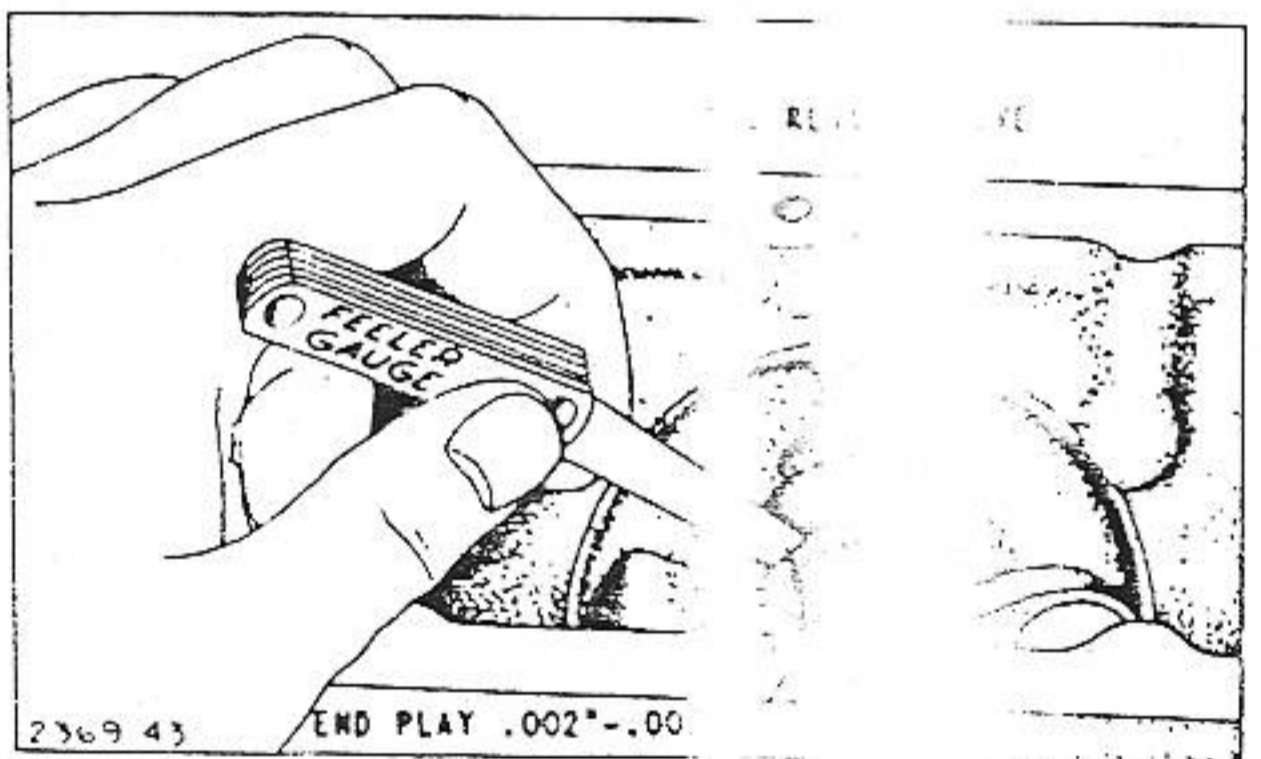


FIG. 148—CHECKING CRANKSHAFT END PLAY

**To Check Crankshaft End Play**

End play on all models is .002" to .005". Check after crankshaft is installed. To check end play with magneto assembled but before tightening crankshaft toward drive side and install thrust face of magneto and crankshaft.

sure to assemble crankcase on

and crankpin as shown to 13A33-T1\*. A piece of 1/8" round cold rolled steel is used as a pin between the two ends of the wrenches, and the set screw is tightened until this 1/8" cold rolled steel is held in place. Allow end play of about .005" on cam before tightening set screw.

1/2" hexagon socket and T handle.



Check after engine is assembled. Push crankshaft toward drive side and install thrust face of magneto and crankshaft. Fig. 149.

The end play may also be determined with the use of a dial indicator as shown in Fig. 149. In this case, the engine should be firmly anchored so amount shown on dial is the true end play and does not include movement of the complete engine.

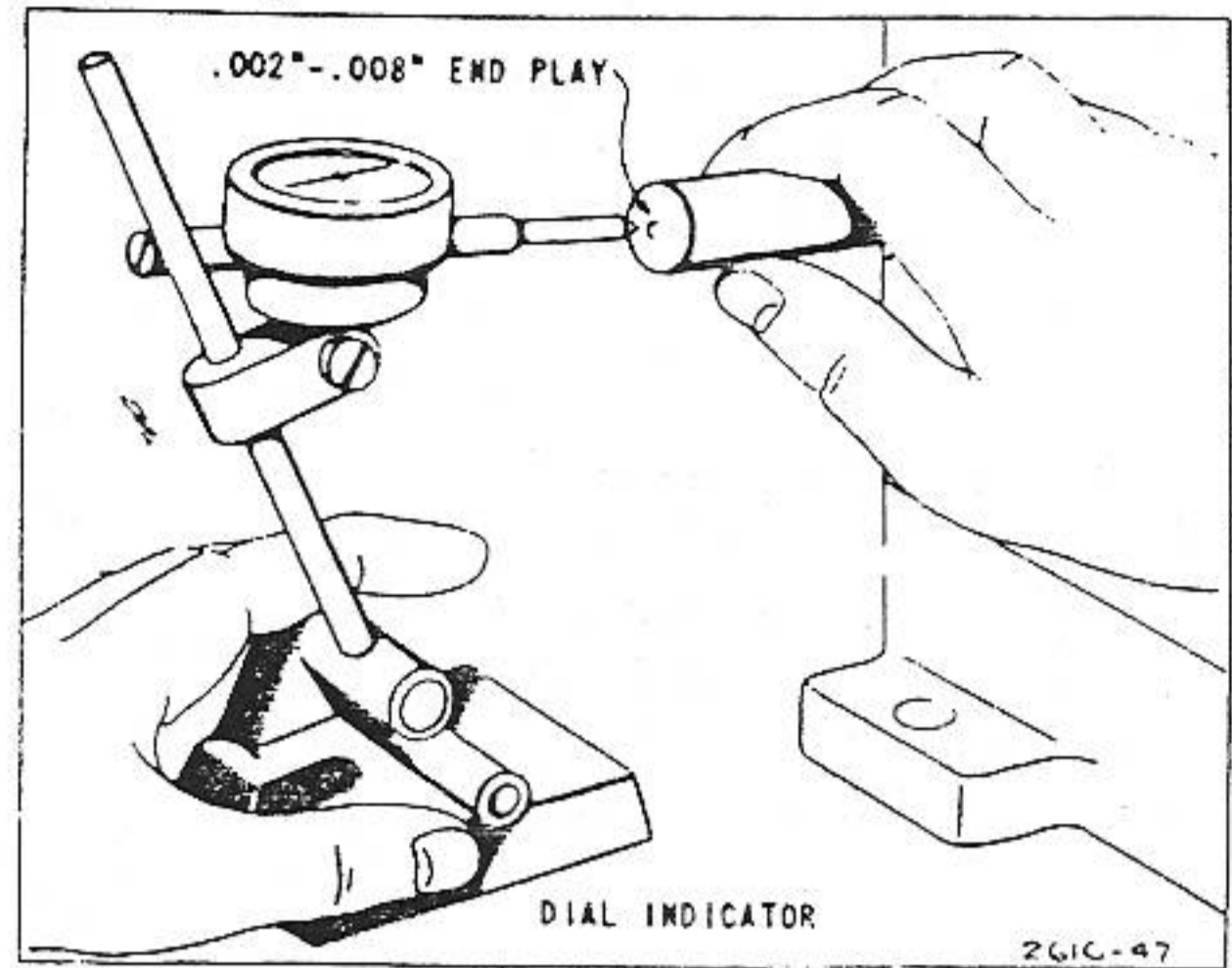


FIG. 149—CHECKING END PLAY

A third method of checking end play is as follows: Push crankshaft toward drive side as far as it will go. Place End Play Gauge No. MPJ-T11 or 95301-T1 with the SHORT legs of cross bar against machined surface of crankcase. (See Tool List Chapter 12 for correct gauge for each model.) Push pin against thrust face of crankshaft and tighten set screw. Fig. 150. Be sure crankshaft is centered and held firmly against drive side.

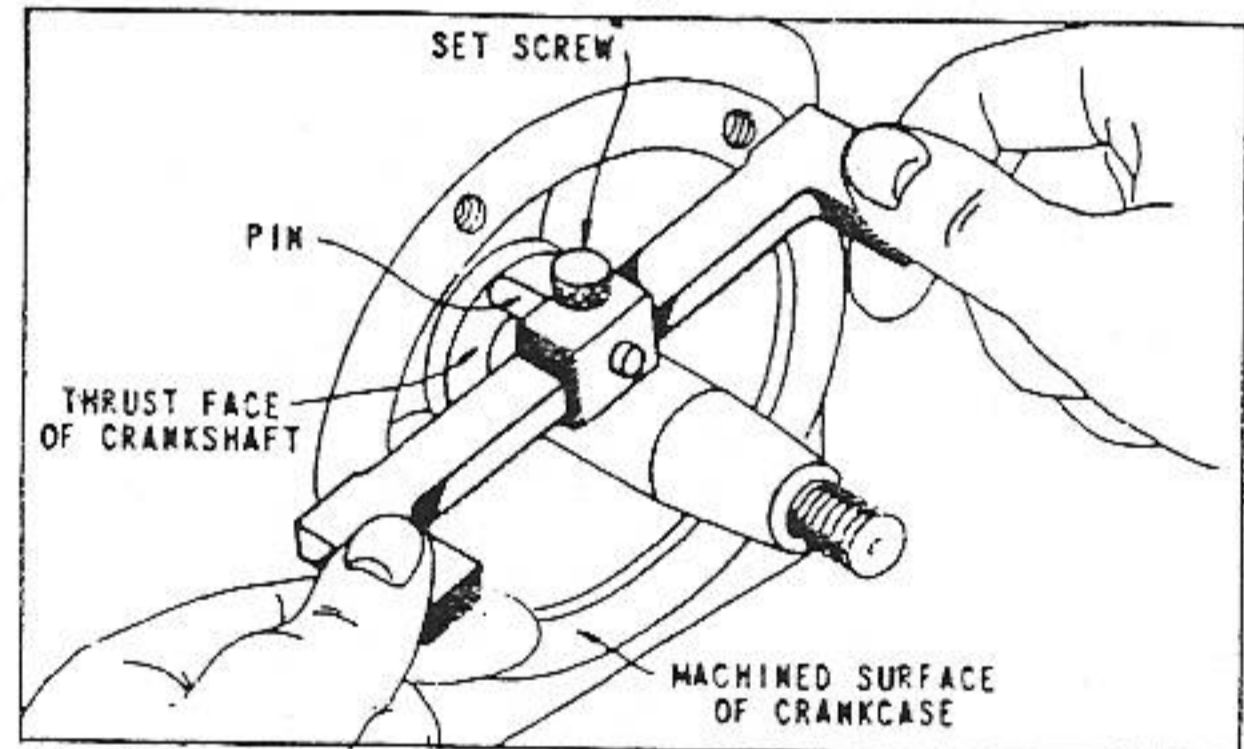


FIG. 150—SET END PLAY GAUGE

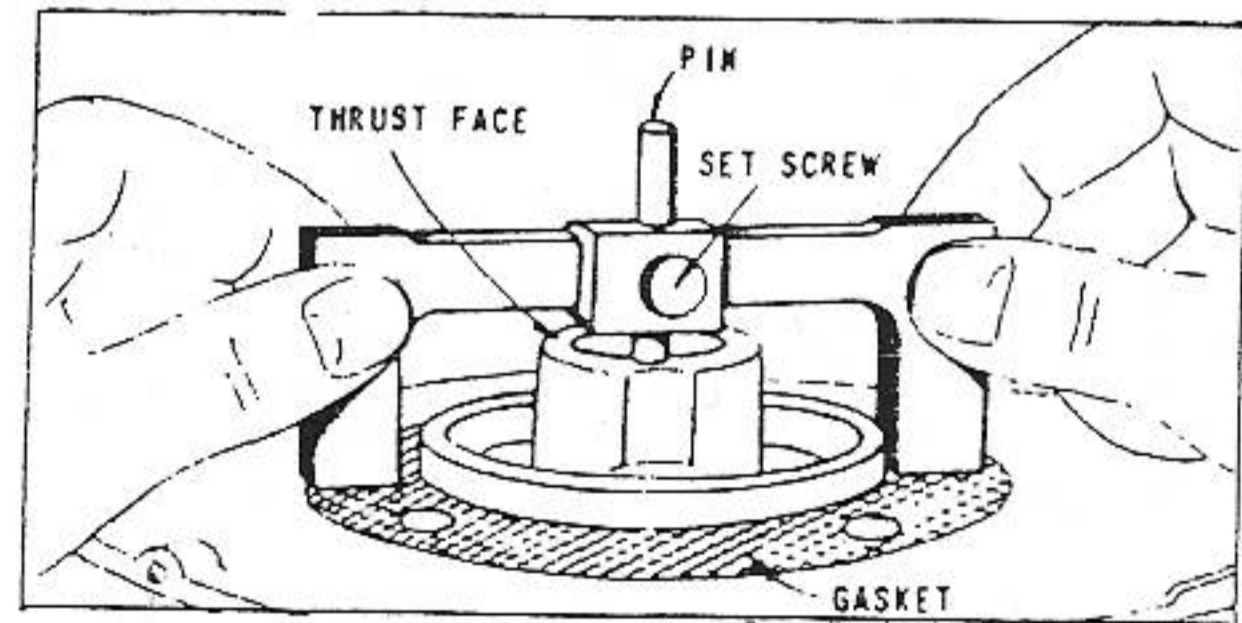


FIG. 151—CHECKING END PLAY

Lay magneto with thrust face up. Put a standard .015" magneto gasket in place. Place end play gauge on magneto with long legs of crossbar against gasket on machined mounting face of magneto. Fig. 151. If end play is correct, the gauge will touch all three points. If there is not enough end play, the pin will touch thrust face and there will be clearance at the leg of crossbar. If end play is too great, the clearance will be at the pin.

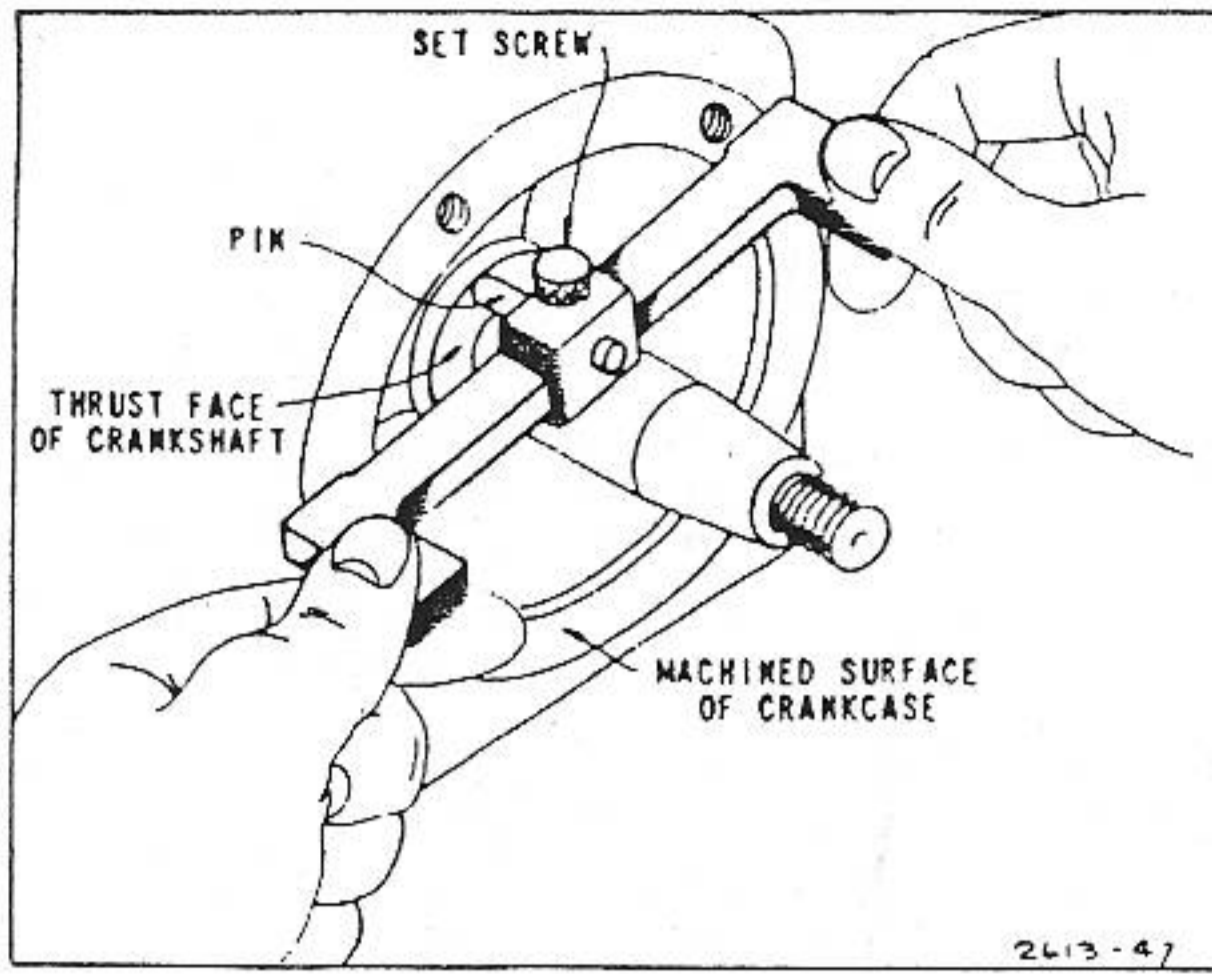


FIG. 150—SET END PLAY GAUGE

**To Correct End Play**

The magneto mounting or bearing support gaskets are supplied in three thicknesses—.005", .009" and .015". The proper end play can be obtained by using one or more of these gaskets. If a lathe is available, the end play can be corrected by setting the end play gauge as explained, then mount the magneto plate in the lathe as shown in Fig. 152. See Chapter 12 and Tool List for arbor number. If end play is too small, set cutting tool at thrust face, point A. If end play is too great, set cutting tool at mounting face, point B.

Check frequently with end play gauge, holding gasket in place. When gauge touches evenly at pin and both legs of crossbar, the end play is correct. Fig. 150 and 151.

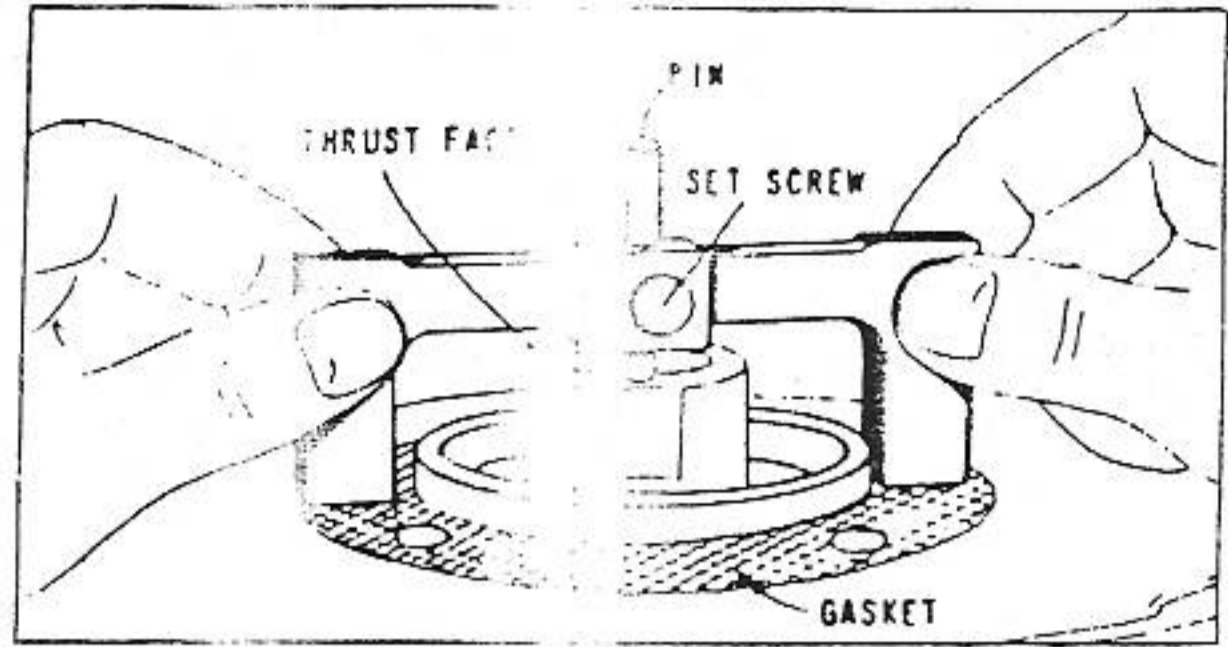


FIG. 151—CORRECTING END PLAY

**To Correct Warped Magneto Plates**

The magneto plate sometimes becomes warped and allows oil to leak at the mounting face. Mount the magneto in lathe as shown in Fig. 152 and turn the mounting face flat BEFORE correcting the end play. This should be done whenever possible.

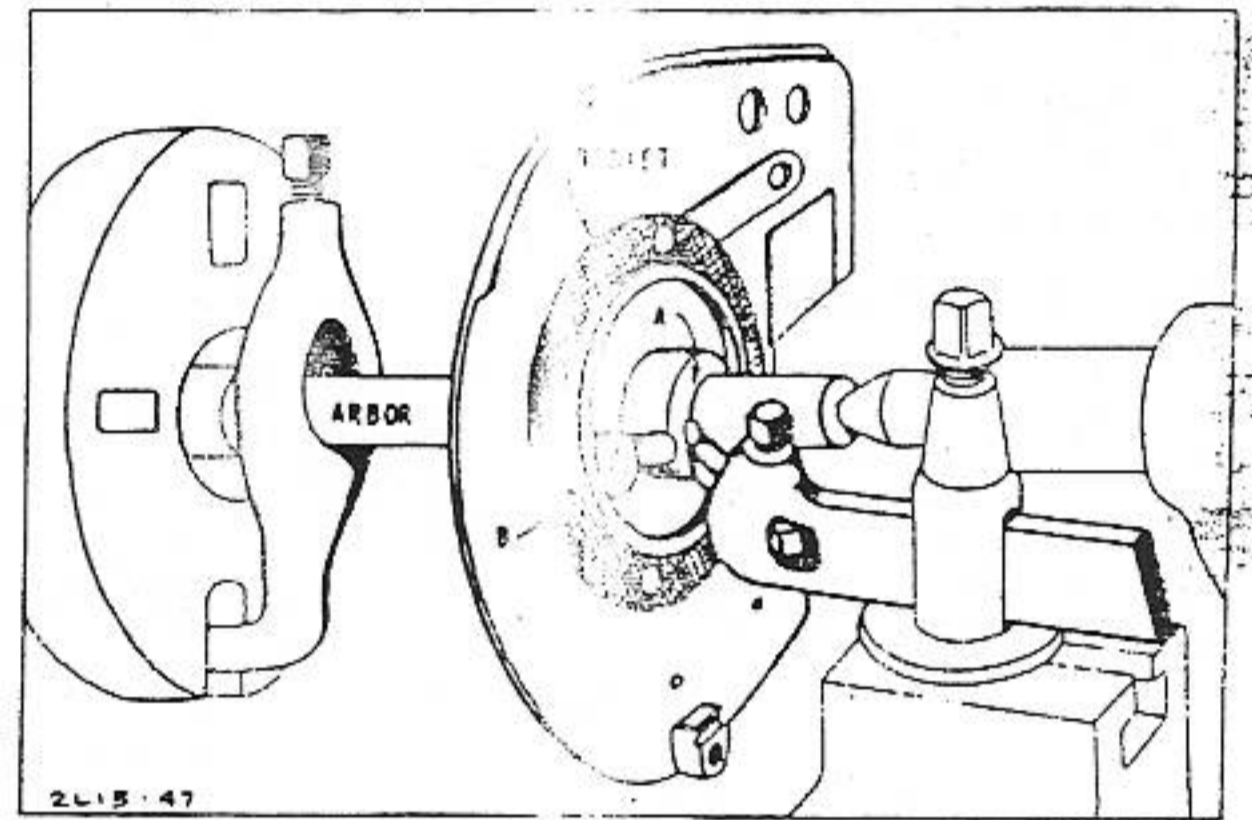


FIG. 152 — CORRECTING END PLAY

## CYLINDERS

### Cylinder Inspection

Always inspect the cylinder after the engine has been disassembled. Visual inspection will show if there are any cracks, stripped bolt holes, broken fins, or if the cylinder wall is scored. Use an accurate micrometer or dial indicator to determine the size of the cylinder bore. Measure at right angles at about the center of the ring travel. Fig. 153. Table 19 lists the standard cylinder bore sizes.

IF THE CYLINDER BORE IS MORE THAN .003" OVERSIZE OR .0015" OR MORE OUT OF ROUND, OR BOTH, IT MUST BE RESIZED.

TABLE NO. 19  
STANDARD CYLINDER BORE DIMENSIONS

| MODEL | STANDARD CYL. BORE DIM. |        | MODEL | STANDARD CYL. BORE DIM. |        |
|-------|-------------------------|--------|-------|-------------------------|--------|
|       | MAX.                    | MIN.   |       | MAX.                    | MIN.   |
| A     | 2.2500                  | 2.2490 | T     | 2.2500                  | 2.2490 |
| B     | 2.6250                  | 2.6240 | U     | 2.000                   | 1.9990 |
| FH    | 2.2500                  | 2.2490 | W     | 2.7505                  | 2.7500 |
| FI    | 2.2500                  | 2.2490 | WI    | 2.000                   | 1.9990 |
| FJ    | 2.2505                  | 2.2500 | WM    | 2.000                   | 1.9990 |
| H     | 2.2500                  | 2.2490 | WMB   | 2.000                   | 1.9990 |
| I     | 2.000                   | 1.9990 | WMI   | 2.000                   | 1.9990 |
| IBP   | 2.000                   | 1.9990 | Y     | 2.2500                  | 2.2490 |
| K     | 2.7505                  | 2.7500 | Z     | 3.000                   | 2.9995 |
| L     | 2.2500                  | 2.2490 | ZZ    | 3.000                   | 2.9995 |
| M     | 2.2500                  | 2.2490 | 5     | 2.000                   | 1.9990 |
| N-NS  | 2.000                   | 1.9990 | 6     | 2.000                   | 1.9990 |
| PB*   | 2.5005                  | 2.5000 | 8     | 2.2500                  | 2.2490 |
| O     | 2.7505                  | 2.7500 | 9     | 2.2500                  | 2.2490 |
| R     | 2.7505                  | 2.7500 | 14    | 2.6250                  | 2.6240 |
| S     | 2.2500                  | 2.2490 | 23    | 3.000                   | 2.9995 |

\* CAN BE REBORED ONLY WITH A CYLINDER GRINDER OR BORING MACHINE

PISTON RING GAP SHOULD BE FROM .007" TO .017"

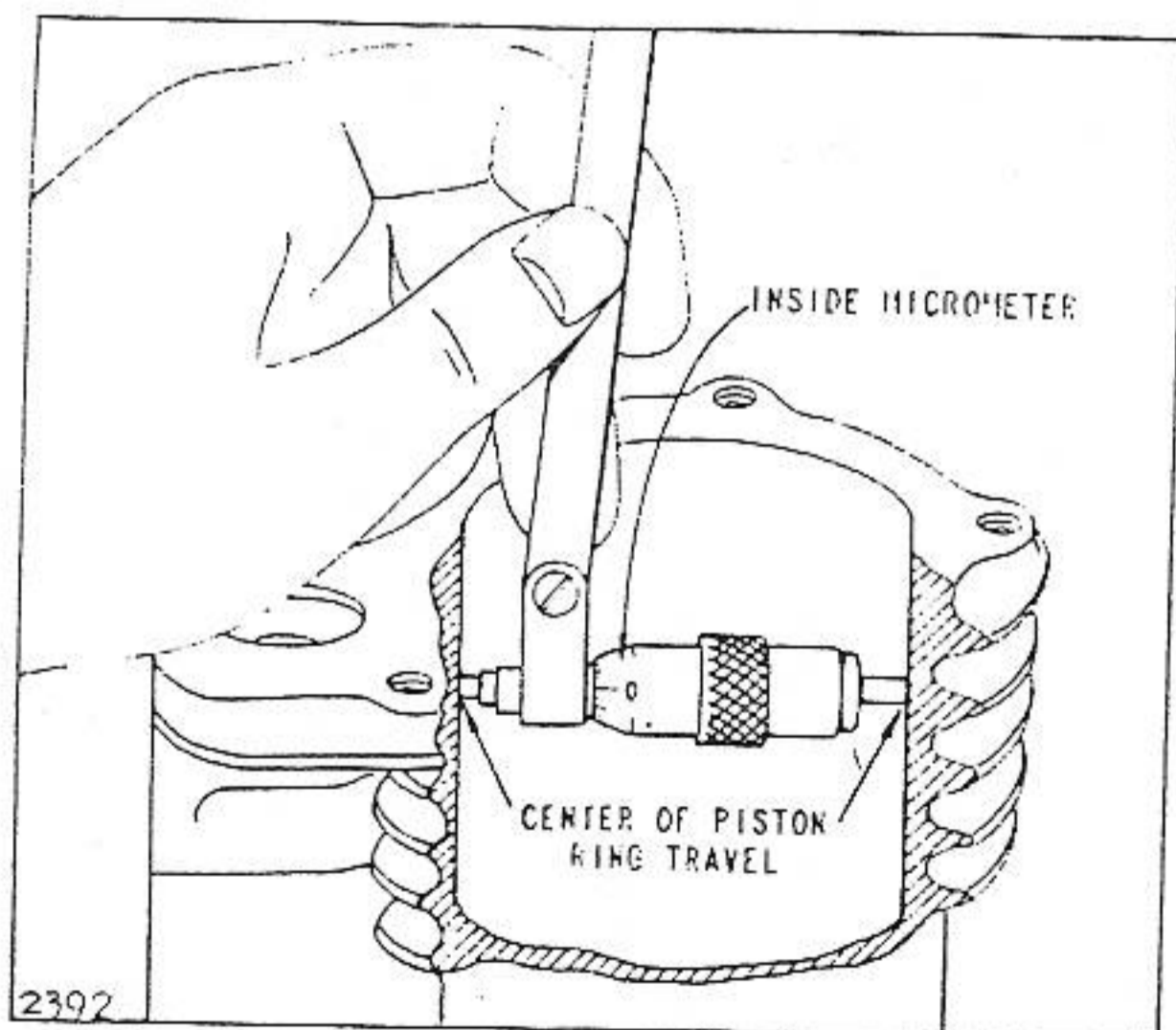


FIG. 153—CHECKING CYLINDER BORE

### Cylinder Resizing

ALWAYS RESIZE TO EXACTLY .010", .020", OR .030" OVER STANDARD SIZE. If this is done accurately, the stock oversize rings and pistons will fit perfectly and proper clearances will be maintained.

The cylinder can be resized by reboring or it can be quickly and accurately honed by using a good hone such as the Sunnen Cylinder Grinder. When using these hones, it is important to start honing at the bottom and gradually work up. The bottom of the bore is usually round and true and will act as a guide for the honing stones. Use a discarded cylinder to practice on at first until you are familiar with the action of the hone, the amount of tension required, etc.

Small scratches in the cylinder bore may sometimes be removed with the hone without enlarging the bore more than .003" above standard.

Resizing with a hone can be done with a portable electric drill. However, since it is important to keep the cylinder bore in perfect alignment with the crankshaft crossbore, it is best to do this on a drill press.

### To Set Up for Honing

Clean cylinder at top and bottom to remove burrs and pieces of base and head gaskets. Fasten cylinder to a heavy iron plate. Oil surface of drill press table liberally. Set plate and cylinder on drill press table. (Do not anchor to drill press.) If using portable drill, set plate and cylinder on floor. Place hone drive shaft in chuck of drill press or portable drill.

Slip hone into cylinder, connect drive shaft to hone and set stop on drill press so hone can only extend 3/4" to 1" from top or bottom of cylinder. If using a portable drill, cut a wood block to place inside of cylinder as a stop for hone. Disconnect drive shaft from hone and raise it out of the way.

### To Hone Cylinder

Place hone in middle of cylinder bore. Tighten adjusting knob with finger or small screw driver until stones fit snugly against cylinder wall. DO NOT FORCE. Hone should operate at 300 to 700 R.P.M.

Connect drive shaft to hone. Be sure that cylinder and hone are centered and aligned with drive shaft and drill spindle. Start drill and as hone spins, move it up and down at lower end of cylinder. The cylinder is not worn at the bottom but is round so it will guide the hone to straighten cylinder bore. Gradually increase strokes until hone travels full length of bore but do not extend hone more than 3/4" to 1" at either end of cylinder bore.

As cutting tension decreases, stop hone and tighten adjusting knob. (Some hones like the Sunnen are used dry. Others such as the Automotive Maintenance Mach. Co., should be wet with a mixture of 3 parts kerosene to one part of oil.)

(See Following Page)

Check cylinder bore frequently with an accurate micrometer. Hone about .0005" large to allow for shrinkage when cylinder cools.

Change from rough stone to finishing stone when within .0015" of desired size, then use finishing stones. Always hone .010", .020" or .030" above standard dimensions given in Table 19.

### Cylinder Welding

Always remember that welding creates extreme localized heat which may cause warping, distortion, misalignment, cracking or breaking.

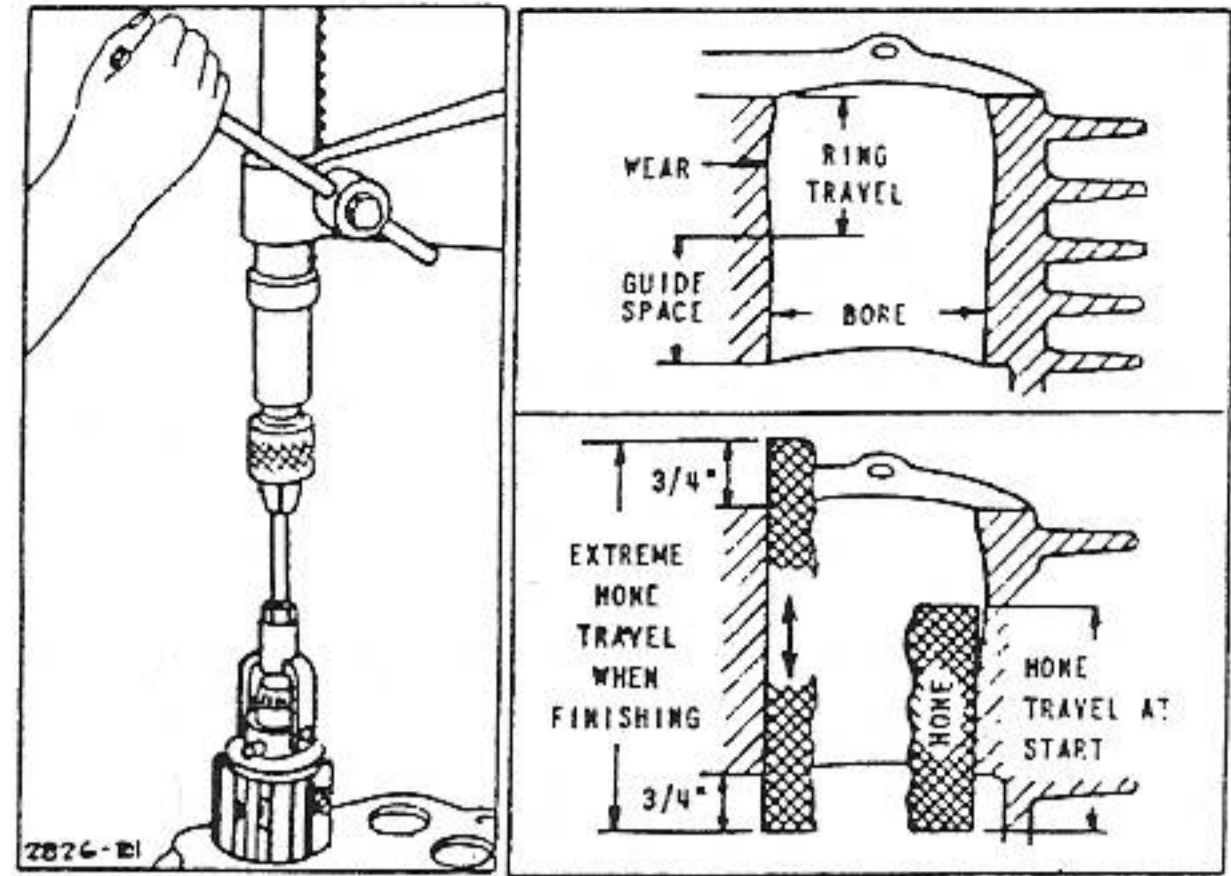


FIG. 154—HONING WITH DRILL PRESS

# BEARINGS

## Main Bearings

The main bearings consist of the magneto bearing and the drive bearing. The magneto bearing is a bushing pressed into the magneto plate and reamed to size. The drive bearing may be either a bushing or a ball bearing and may be mounted either in the crankcase or on a removable plate called the crankcase cover. The bushing type of bearing is very efficient but extreme care must be

taken to maintain the proper clearance between the crankshaft journal and the bearing surface. Too little clearance will cut off the oil supply and too much will cause excessive vibration and wear. If both main bearings and crankshaft journals are within the proper limits, this clearance will be maintained.

(See Following Page)

TABLE NO. 20 - TOOLS FOR REAMING BEARINGS

| ENG. MODEL | MAGNETO BEARING                |                                   |                                    |                               | DRIVE BEARING                |                                 |                                      |                             | LINE REAMER TO FIT MAGNETO & DRIVE BEARING |
|------------|--------------------------------|-----------------------------------|------------------------------------|-------------------------------|------------------------------|---------------------------------|--------------------------------------|-----------------------------|--|
|            | GAUGE TO CHECK MAGNETO BEARING | DRIVER TO REPLACE MAGNETO BEARING | GUIDE BUSHING TO FIT DRIVE BEARING | REAMER TO FIT MAGNETO BEARING | GAUGE TO CHECK DRIVE BEARING | DRIVER TO REPLACE DRIVE BEARING | GUIDE BUSHING TO FIT MAGNETO BEARING | REAMER TO FIT DRIVE BEARING |  |
| A          | 69821-T3                       | 69876-T1                          | 60225-T1-74                        | 60225-T1-24                   | 65116-T3                     | 29076-T3                        | 60225-T1-14                          | 60225-T1-64                 |  |
| AP         | 69821-T3                       | 69876-T1                          | 60225-T1-94                        | 60225-T1-24                   | BB                           | BB                              | BB                                   | BB                          |  |
| B          | 69821-T3                       | 69876-T1                          | 60225-T1-4                         | 60225-T1-24                   | 66439-T3                     | 69876-T1                        | 60225-T1-14                          | 60225-T1-34                 |  |
| BP         | 69821-T3                       | 69876-T1                          | 60225-T1-54                        | 60225-T1-24                   | BB                           | BB                              | BB                                   | BB                          |  |
| FH         | MPJ-T9                         | 69093-T1                          |                                    | *                             | 69093-T4                     | 69093-T1                        |                                      |                             | 69094-T4                                   |
| FI         | MPJ-T9                         | 69093-T1                          |                                    |                               | 69093-T4                     | 69093-T1                        |                                      |                             | 69094-T4                                   |
| FJ         | MPJ-T9                         | 69093-T1                          |                                    |                               | 69093-T4                     | 69093-T1                        |                                      |                             | 69094-T4                                   |
| H          | 69821-T3                       | 69876-T1                          | 60225-T1-74                        | 60225-T1-24                   | 65116-T3                     | 29076-T3                        | 60225-T1-14                          | 60225-T1-84                 |  |
| I          | *62552-T1                      | 29746-T3                          | 60732-T2-44                        | 60732-T2-24                   | 62552-T1                     | 29746-T3                        | 60732-T2-14                          | 60732-T2-24                 |  |
| IBP        | 62552-T1                       | 29746-T3                          | 60732-T2-44                        | 60732-T2-24                   | BB                           | BB                              | BB                                   | BB                          |  |
| K          | 69821-T3                       | 69876-T1                          | 60225-T1-4                         | 60225-T1-24                   | 66439-T3                     | 69876-T1                        | 60115-T1-14                          | 60225-T1-34                 |  |
| L          | MPJ-T9                         | 69093-T1                          |                                    |                               | 69093-T4                     | 29746-T3                        |                                      |                             | 69094-T4                                   |
| M          | MPJ-T9                         | 69093-T1                          |                                    |                               | 69093-T4                     | 29746-T3                        |                                      |                             | 69094-T4                                   |
| N          | 62552-T1                       | 29746-T3                          | 60732-T2-14                        | 60732-T2-24                   | 62552-T1                     | 29746-T3                        | 60732-T2-14                          | 60732-T2-24                 |  |
| NP         | 62552-T1                       | 29746-T3                          | 60732-T2-44                        | 60732-T2-24                   | BB                           | BB                              | BB                                   | BB                          |  |
| NS         | 62552-T1                       | 29746-T3                          | 60732-T2-14                        | 60732-T2-24                   | 62552-T1                     | 29746-T3                        | 60732-T2-14                          | 60732-T2-24                 |  |
| PB         | MPJ-T9                         | 69093-T1                          |                                    |                               | 69265-T2                     | 29076-T3                        |                                      |                             | 69265-T1                                   |
| Q          | MPJ-T9                         | 69093-T1                          |                                    |                               | 66439-T3                     | 29347-T1                        |                                      |                             | 69054-T2                                   |
| R          | MPJ-T9                         | 69093-T1                          |                                    |                               | 66439-T3                     | 29347-T1                        |                                      |                             | 69054-T2                                   |
| S          | MPJ-T9                         | 69093-T1                          |                                    |                               | 69093-T4                     | 29746-T3                        |                                      |                             | 69094-T4                                   |
| T          | MPJ-T9                         | 69093-T1                          |                                    |                               | 69093-T4                     | 29746-T3                        |                                      |                             | 69094-T4                                   |
| U          | 62552-T1                       | 29746-T3                          | 60732-T2-14                        | 60732-T2-24                   | 62552-T1                     | 29746-T3                        | 60732-T2-14                          | 60732-T2-24                 |  |
| W          | MPJ-T9                         | 69093-T1                          |                                    |                               | 66439-T3                     | 29347-T1                        |                                      |                             | 69054-T2                                   |
| WI         | 62552-T1                       | 29746-T3                          | 60732-T2-14                        | 60732-T2-24                   | 62552-T1                     | 29746-T3                        | 60732-T2-14                          | 60732-T2-24                 |  |
| WM         | 62552-T1                       | 29746-T3                          | 60732-T2-14                        | 60732-T2-24                   | 62552-T1                     | 29746-T3                        | 60732-T2-14                          | 60732-T2-24                 |  |
| WMB        | 62552-T1                       | 29746-T3                          | 60732-T2-14                        | 60732-T2-24                   | 62552-T1                     | 29746-T3                        | 60732-T2-14                          | 60732-T2-24                 |  |
| WMI        | 62552-T1                       | 29746-T3                          | 60732-T2-14                        | 60732-T2-24                   | 62552-T1                     | 29746-T3                        | 60732-T2-14                          | 60732-T2-24                 |  |
| Y          | 69821-T3                       | 69876-T1                          | 60225-T1-74                        | 60225-T1-24                   | 65116-T3                     | 29076-T3                        | 60225-T1-14                          | 60225-T1-84                 |  |
| Z          | 69821-T3                       | 69876-T1                          | 60225-T1-64                        | 60225-T1-24                   | BB                           | BB                              | BB                                   | BB                          |  |
| ZZ         | 69821-T3                       | 69876-T1                          | 60225-T1-64                        | 60225-T1-24                   | BB                           | BB                              | BB                                   | BB                          |  |
| 5          | 62552-T1                       | 29746-T3                          | 60732-T2-14                        | 60732-T2-24                   | 62552-T1                     | 29746-T3                        | 60732-T2-14                          | 60732-T2-24                 |  |
| 6          | 62552-T1                       | 29746-T3                          | 60732-T2-14                        | 60732-T2-24                   | 62552-T1                     | 29746-T3                        | 60732-T2-14                          | 60732-T2-24                 |  |
| 8          | 62552-T1                       | 29746-T3                          | 60732-T2-14                        | 60732-T2-24                   | 62552-T1                     | 29746-T3                        | 60732-T2-14                          | 60732-T2-24                 |  |
| 9**        | 291227-T8                      |                                   |                                    |                               | 291227-T8                    |                                 |                                      |                             |  |
| 14**       | 291227-T8                      |                                   |                                    |                               | 291227-T8                    |                                 |                                      |                             |  |
| 23**       | 291227-T8                      |                                   |                                    |                               | 291227-T8                    |                                 |                                      |                             |  |

\* On Model \*I\* with ball bearing drive use same tools and specification as Model \*IBP\*.

\*\* On Models 9, 14 and 23 when worn beyond Max. replace entire bearing support assembly or crankcase cover.

NOTE: With all 60225 reamers use 60225-T1-44 pilot.  
With all 60732 reamers use 60732-T2-34 pilot.

For illustration or information on any tool see Chapter 12.

There are three major steps required in repairing the main bearings: (1) Check, (2) Remove and Install, and (3) Ream.

**To Inspect Bearing**

If bearing is scored or babbitt has shifted, the bearing should be removed and a new one installed.

**To Check Bearing**

Refer to Table 20 to determine the proper plug gauge for each bearing. If the "C" or flattened end of plug gauge can be inserted into the bearing at any point, the bearing is worn or out of round and should be replaced. Fig. 155.

The "A" and "B" section of the plug gauge are used to check the bearing after it has been installed and reamed. Section "A" should enter the bearing but Section "B" should not.

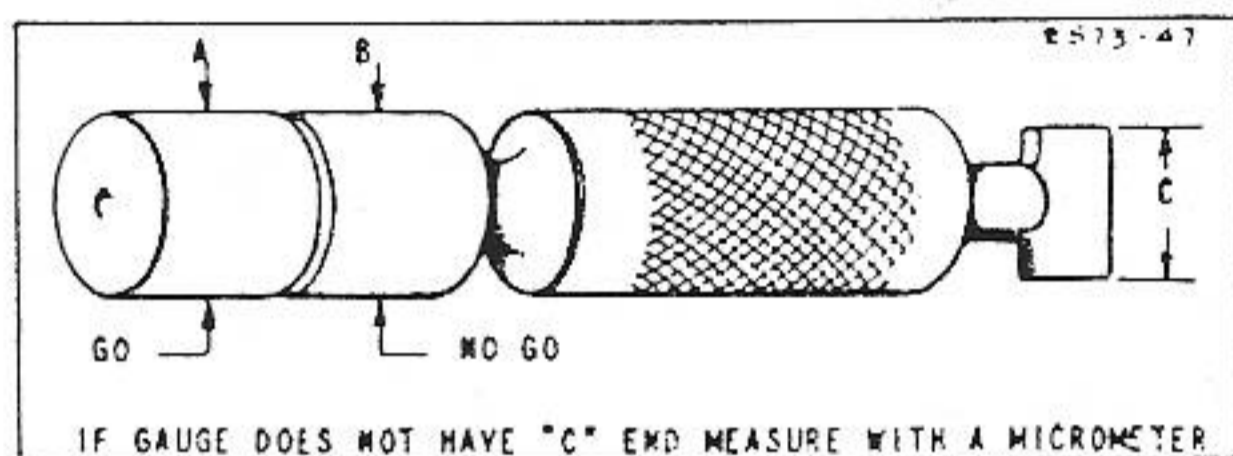


FIG. 155—BEARING PLUG GAUGE

If no plug gauge is available, measure the bearing diameter and compare with the respective size shown in Table 21. If the bearing has a diameter equal to or greater than the given figure, the bearing should be rejected. If bearing is .0007" out of round, it should be rejected. Use plug gauge wherever possible.

**To Remove and Install Plain Bearings**

NOTE: If the bushings are worn on Model 9-14 and 23, the crankcase cover or the bearing support must be replaced with a new one. The bushings are not replaceable. Use one bearing as a guide while reaming the other. It is absolutely necessary to completely repair one bearing before starting on the other.

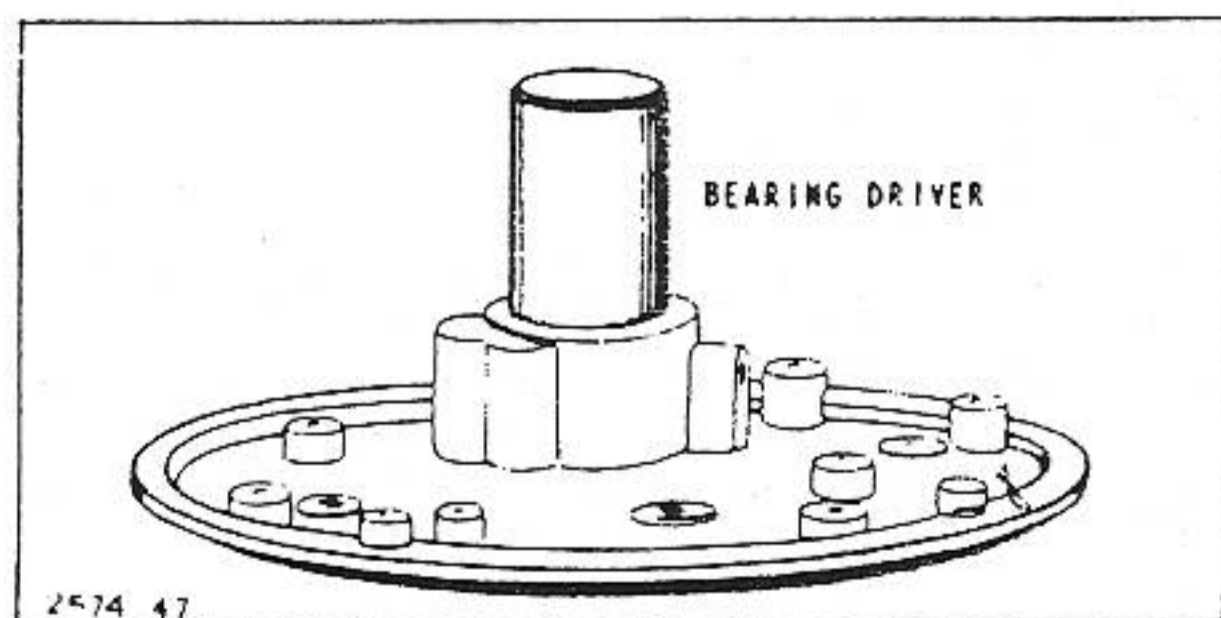


FIG. 156—BEARING DRIVER

**Magneto Bearings**

Select the proper driver to remove and install the bearing. Table 20. Proceed as follows: Remove oil seal retainer. Press out old bearings in arbor press using proper driver. Fig. 156.

NOTE: Some magneto bearings are held in place with a pin through the plate hub into the bearing. Others are secured by staking. A staked bearing may be identified by a notch or notches in the outer end of the bearing, just inside the oil retainer. These notches are made by driving a portion of the bearing into a short groove in the hub.

PRESS ALL BEARINGS INWARD TO REMOVE. PRESS FROM INSIDE TO REPLACE. Fig. 156.

Press in new bearing. Extreme care must be taken to align the oil holes in the bearing with those in the magneto plate hub. Do not press bearing in too far. The inner end of the bearing should be 1/16" from the inner end of thrust face of the hub. (Except on flange type bearing.) Fig. 157.

NOTE: Whenever a FLANGE bearing has been replaced, the end play of the crankshaft must be checked. See Chapter 6 for full information on end play.

(See Following Page)

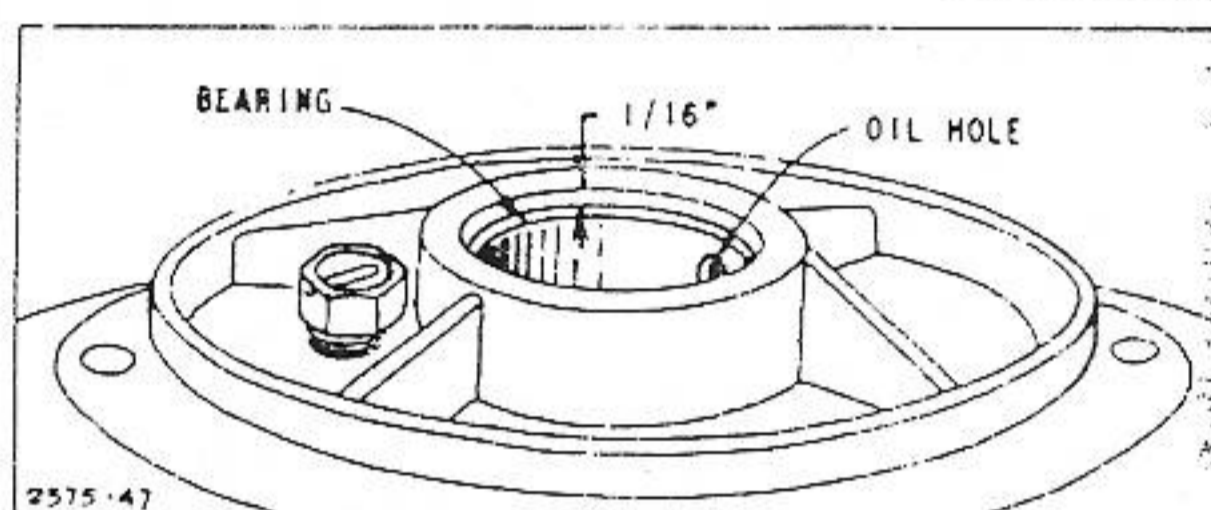


FIG. 157—ALIGNING BEARING

TABLE 21 MAIN BEARING SIZES

| MODEL                   | MAGNETO BEARING      |                     | DRIVE BEARING        |                     |
|-------------------------|----------------------|---------------------|----------------------|---------------------|
|                         | REPLACE AT OR LARGER | REAM NEW BEARING TO | REPLACE AT OR LARGER | REAM NEW BEARING TO |
| A-H-Y                   | 1.097                | 1.096-1.0955        | .997                 | .996-.9955          |
| AHP-AMT-AP              | 1.097                | 1.096-1.0955        | BB                   | BB                  |
| B                       | 1.097                | 1.096-1.0955        | 1.127                | 1.126-1.1255        |
| BM-BP                   | 1.097                | 1.096-1.0955        | BB                   | BB                  |
| FH-FI-FJ-L-M-S-T        | .972                 | .971-.9705          | .877                 | .876-.8755          |
| I-N-NS-NU-WI-WM-WMB-WMI | .878                 | .877-.8764          | .878                 | .877-.8764          |
| IBP-KP-IP               | .878                 | .877-.8764          | BB                   | BB                  |
| K                       | 1.097                | 1.096-1.0955        | 1.127                | 1.126-1.1255        |
| KM-Z-ZZ                 | 1.097                | 1.096-1.0955        | BB                   | BB                  |
| PB                      | .972                 | .971-.9705          | 1.0015               | 1.0005-1.000        |
| Q-R-W                   | .972                 | .971-.9705          | 1.127                | 1.126-1.1255        |
| 5                       | .878                 | .877-.8764          | .878                 | .877-.8764          |
| 6                       | .878                 | .877-.8764          | .878                 | .877-.8764          |
| 9*                      | .9875                |                     | .9675                |                     |
| 14*                     | 1.1843               |                     | 1.1843               |                     |
| 23*                     | 1.3813               |                     | 1.3813               |                     |
| 8                       | .878                 | .877-.8764          | .878                 | .877-.8764          |

Out of Round Allowance .0007"  
 \* On Models 9-14-23 when worn beyond max. replace entire bearing support assembly.

To pin bearing in place, drill a hole through the hub and bearing with a No. 31 drill. On the type of magneto shown in Fig. 158, the hole is drilled in the outer end of hub. On the type of magneto shown in Fig. 160, the hole is drilled in the inner end of hub. On flange type bearings as shown in Fig. 159, drill the hole anywhere in the thrust face except over the oil hole. Insert brass pin (furnished with bearing) into the hole. Drive it in until the tip just enters the steel shell of the bearing but does not go through the babbitt. Peen outer end of hole. On flange type bearing the pin is driven in flush with thrust face.

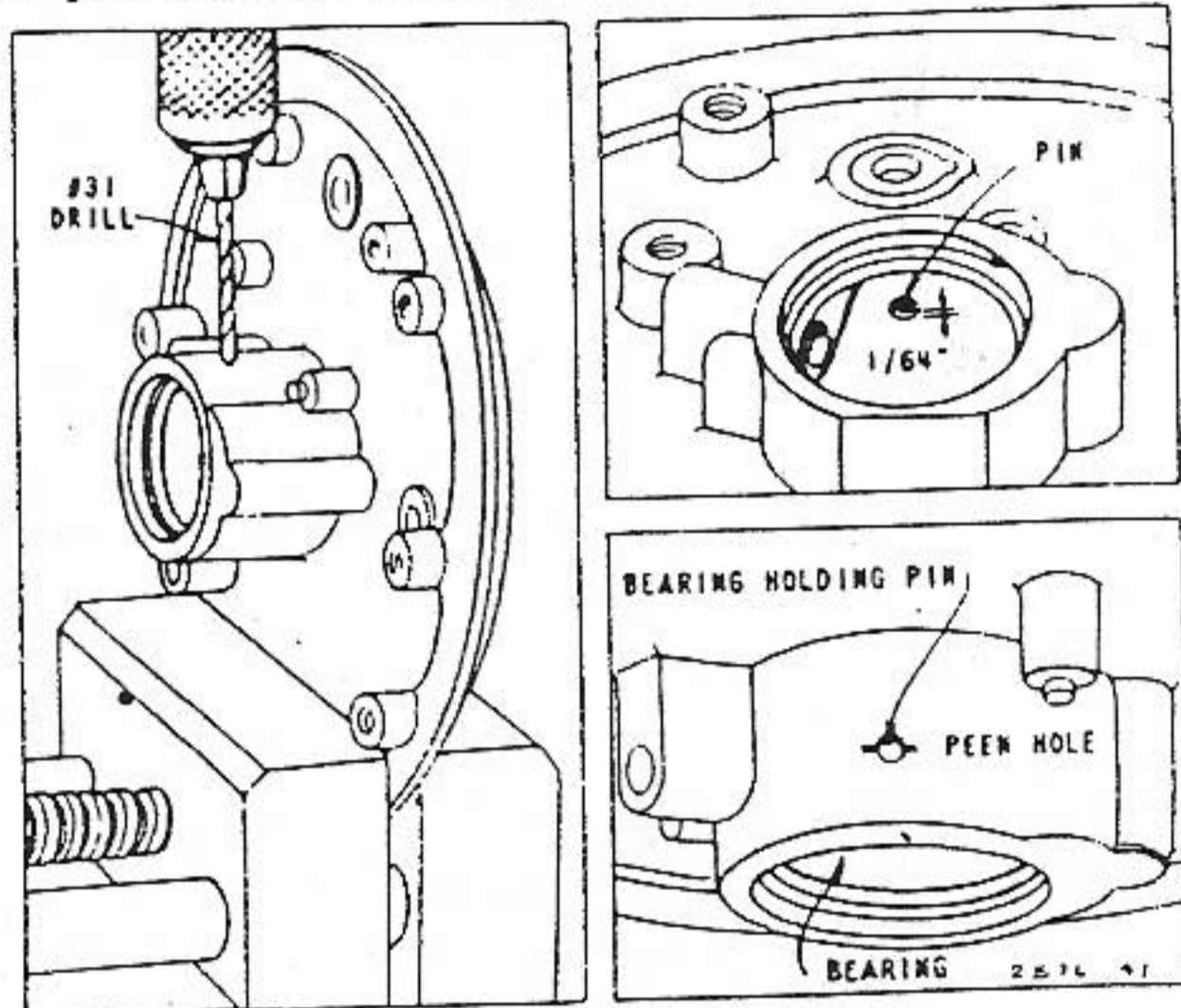


FIG. 158—PINNING BEARING

To stake bearing into place, use a dull chisel or screw driver to drive a small portion of the bearing into the grooves in the magneto plate. Fig. 160.

#### Drive Bearing

The drive bearing may be removed and replaced the same as the magneto bearing, but be sure to use a crankcase support when pressing bearing in or out. Fig. 161. Drive bearings are pinned in place only on Models FH and FI. On these models the flange bearing is pinned on the inside face as on the magneto flange bearing. The straight bearing is pinned at the outer hub of the crankcase.

#### Horizontal Engines

The cylinder bushing on horizontal engines should be flush with the outer end of the bushing hole. If bushing protrudes too far, it will touch the oil seal and close off the oil retaining groove and cause oil to leak.

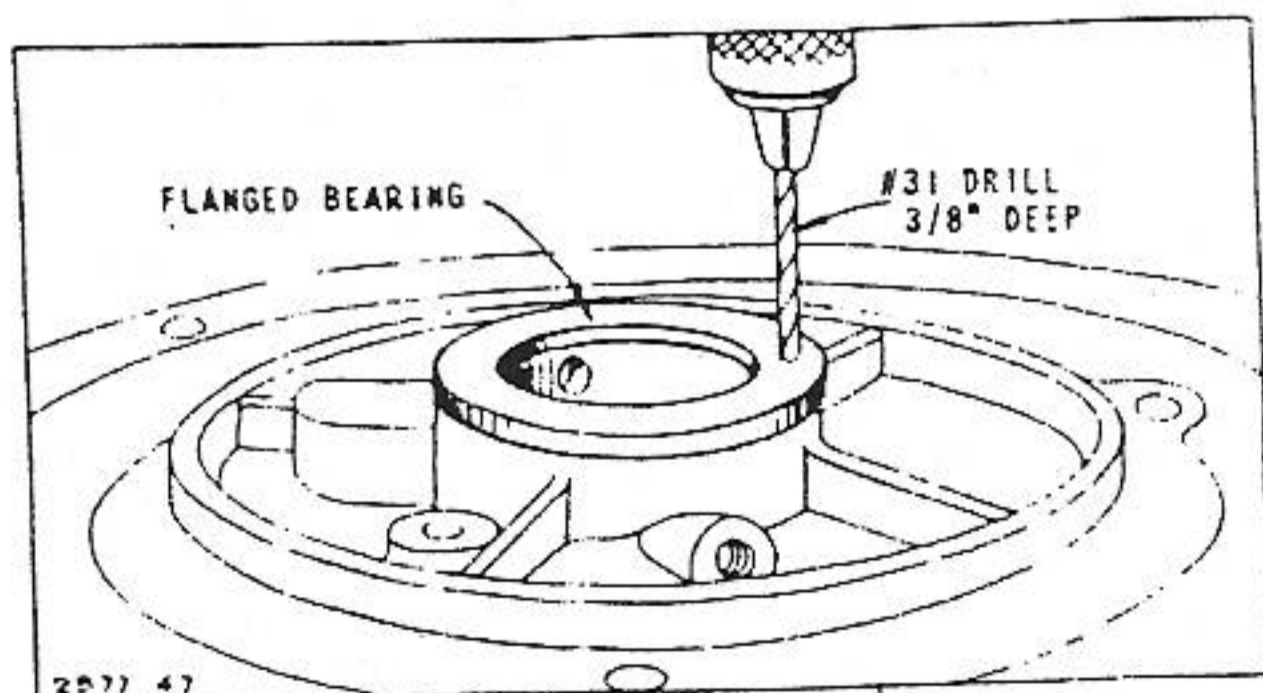


FIG. 159—PINNING FLANGE BEARING

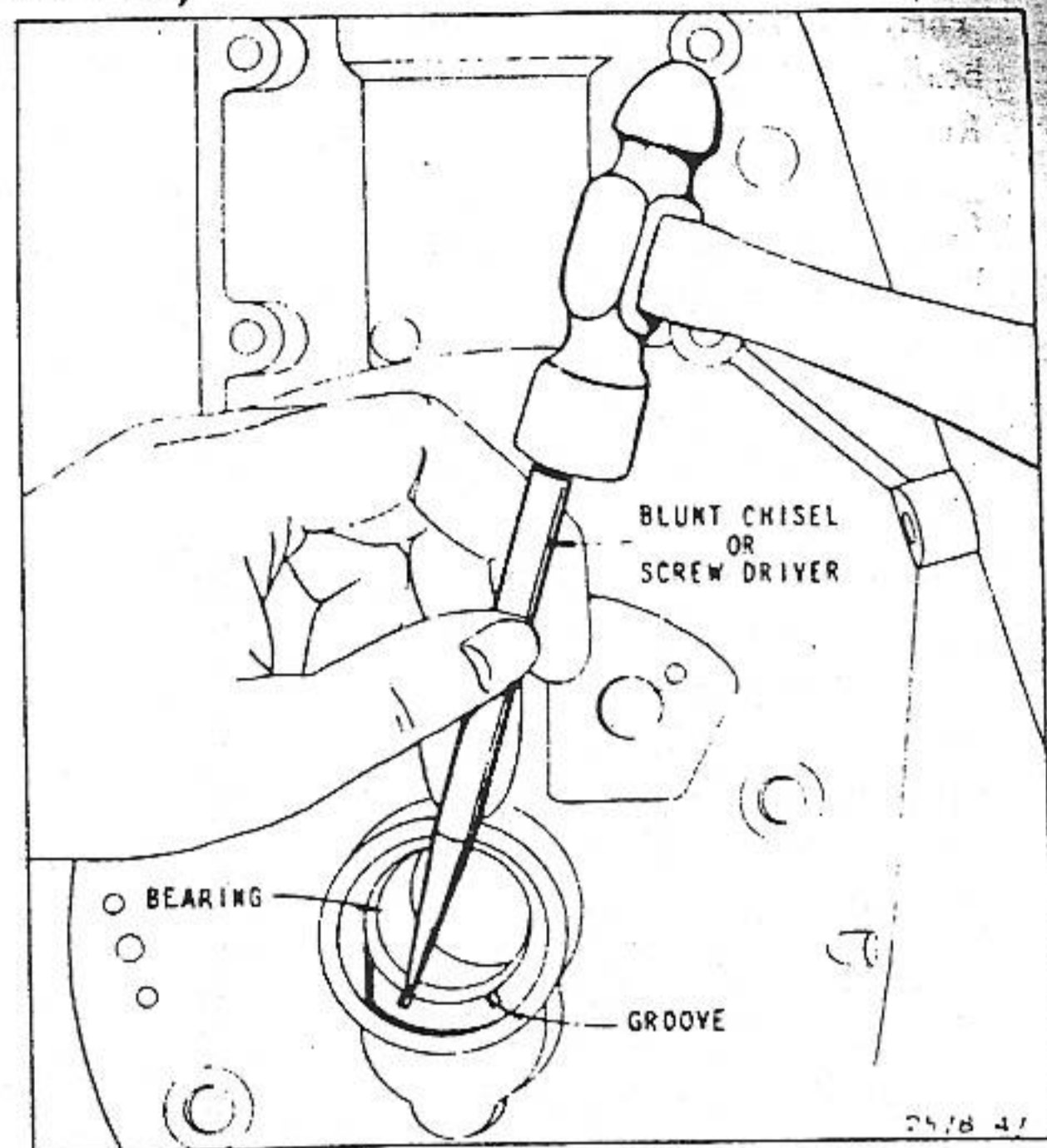


FIG. 160—STAKING BEARING

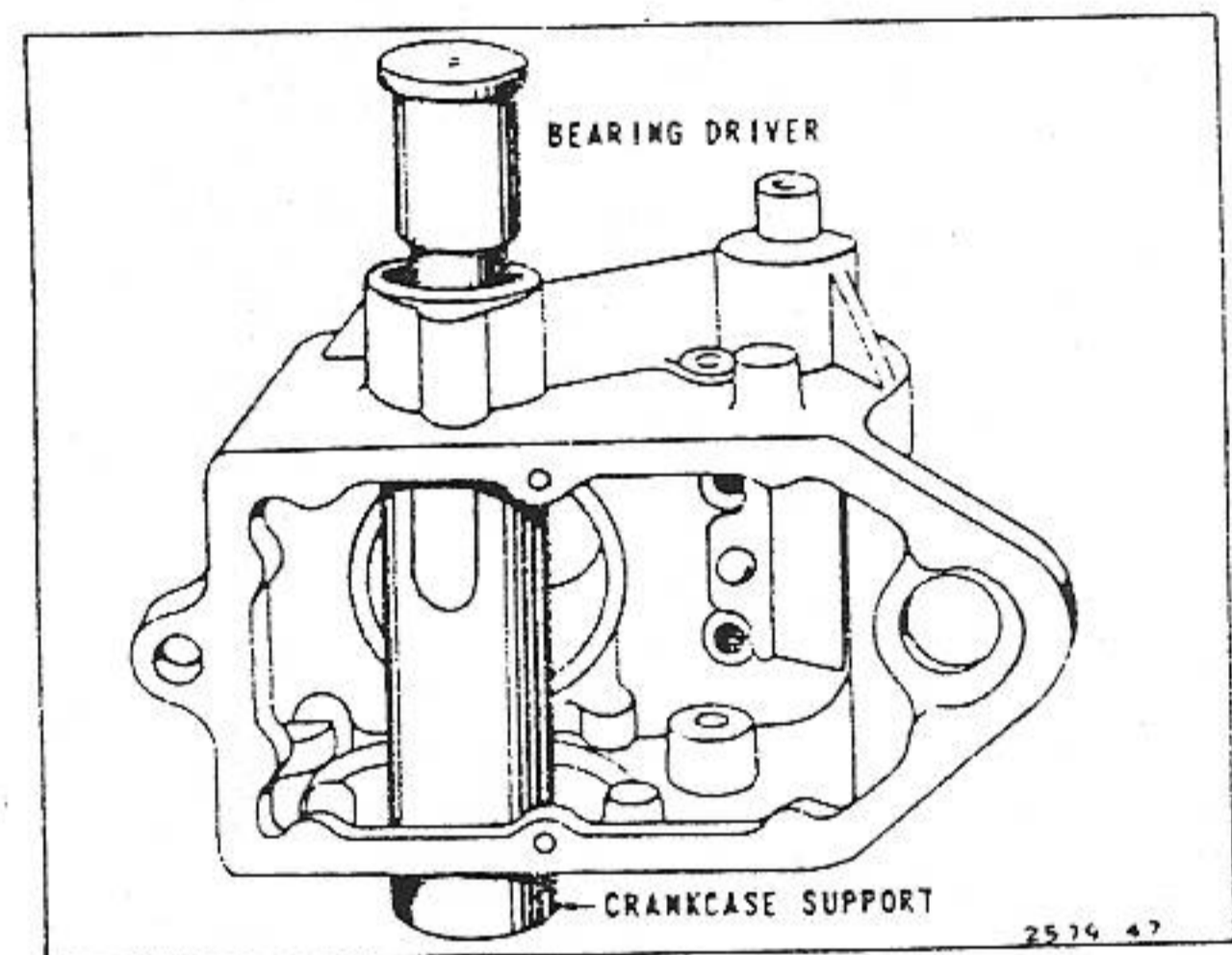


FIG. 161—REMOVING DRIVE BEARING

#### Reaming

Two types of reamers are used for main bearings as you will note in Table 20:

1. The shell reamer—used with a pilot and guide bushing.
2. The line reamer—a solid reamer with two sets of cutting edges called flutes. One set of flutes acts as a guide while the other set is cutting. Never try to ream both bearings at the same time. NOTE: Reamer lubricated with oil will tend to cut a smaller hole than when used dry.

#### To Use Shell Reamer

After bearing has been installed, assemble magneto to cylinder or crankcase. Refer to Table 20 and select proper tools. If "BB" is shown instead of a tool, it indicates that a ball bearing is used on the drive side. The guide bushing listed will fit in the recess in the crankcase. Insert guide bushing in bearing opposite to the one to be reamed from the inside of the crankcase. Place shell reamer on pilot and thrust it into bearing to be reamed. The tip of pilot

should enter guide bushing at opposite side. Fig. 162. Turn reamer clockwise with a steady, even pressure until reamer is completely through bearing. Then remove magneto plate and remove reamer without backing it through the bearing.

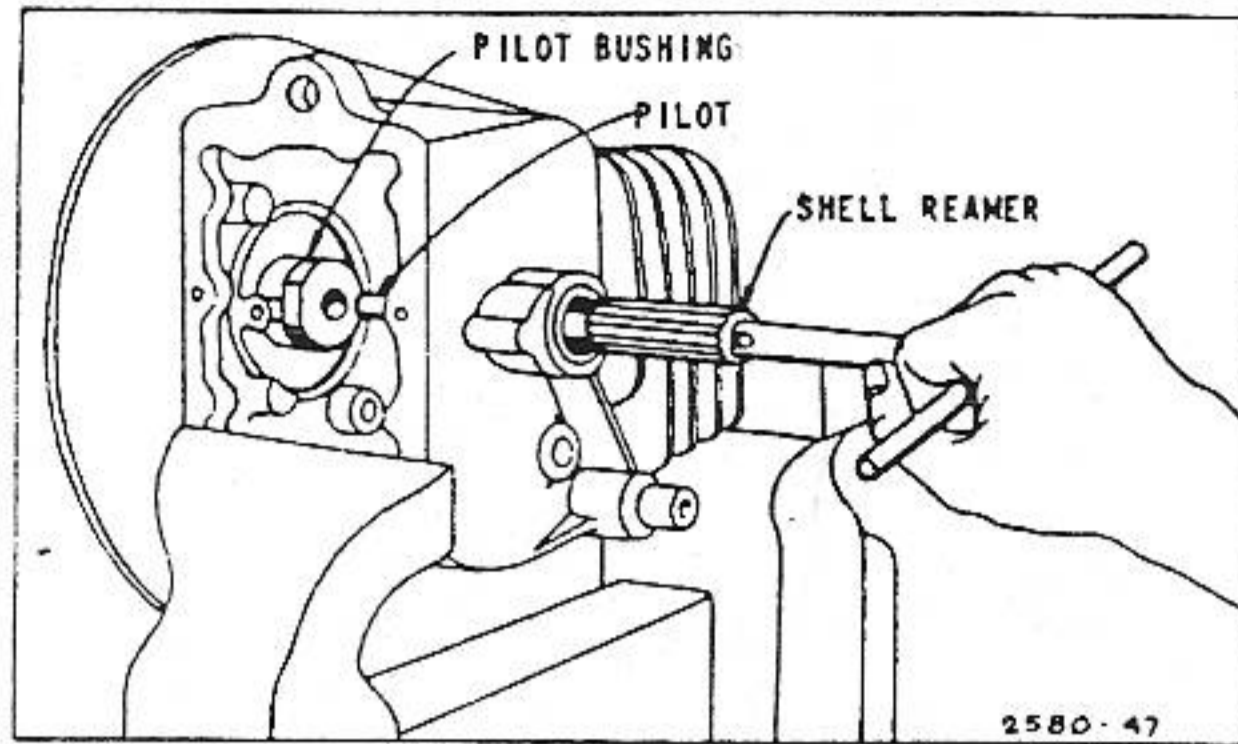


FIG. 162—SHELL REAMING

**To Use Line Reamer**

Mount magneto to crankcase. Select proper reamer. Table 20. Insert reamer through larger bearing regardless of which is to be reamed. The smaller set of flutes enters smaller bearing on opposite side of crankcase. Fig. 163. Then turn reamer clockwise with a steady, even pressure until bearing is completely reamed. Continue to turn reamer clockwise while removing it from bearings.

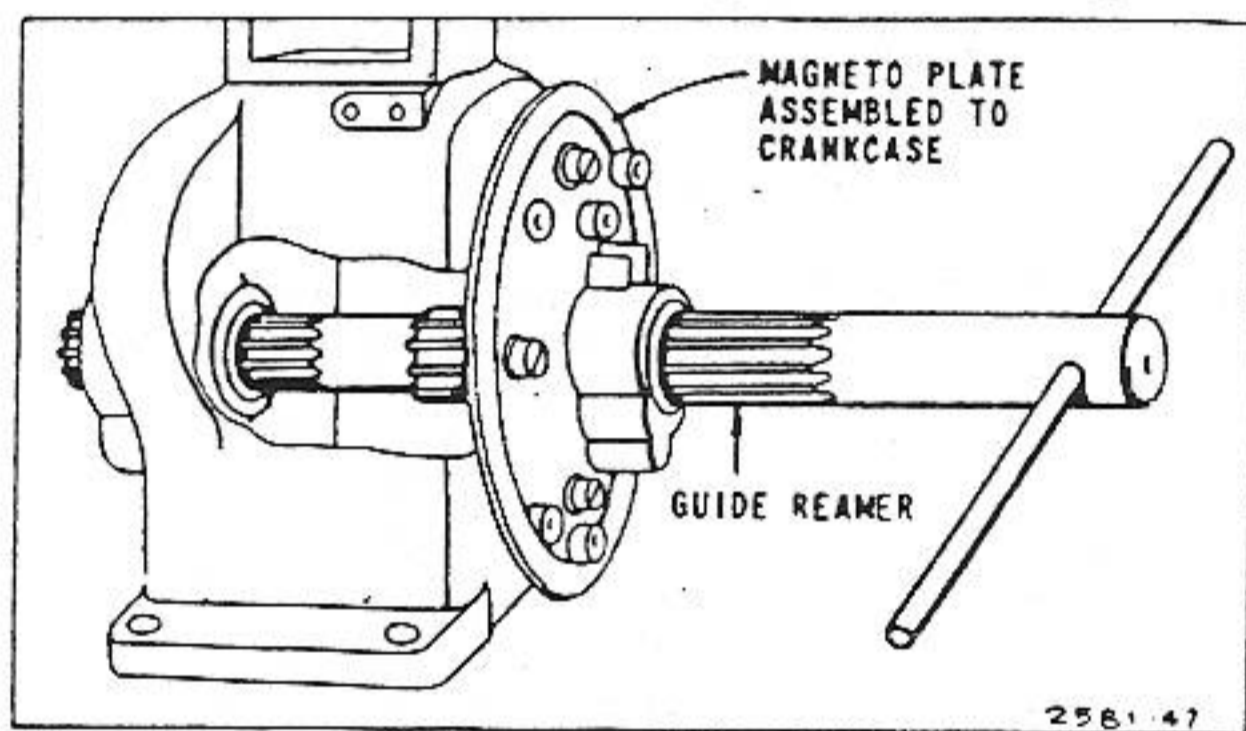


FIG. 163—LINE REAMING

**To Check Bearing for Size After Reaming**

Use the same plug gauge as in inspection, but use "A" and "B" sections. Fig. 155. The "A" section should enter the bearing, but "B" section should not. If "B" enters, the bearing is too large. For bearing sizes see Table 21. After reaming is completed, remove and clean oil sucker valve and be sure oil return passages are clean and free from chips. Replace oil valves.

Install new oil retainer rings which are included with respective bearings.

**BEARING OIL RETAINER**

The bearing oil retainer rings consist of four types: (1) The Flange Type, (2) The Cup Type, (3) The Washer Type and (4) The Oil Seal. Fig. 164. Extreme care must be taken to prevent damage to the oil seal when assembling the crankshaft. Fig. 146. and 165

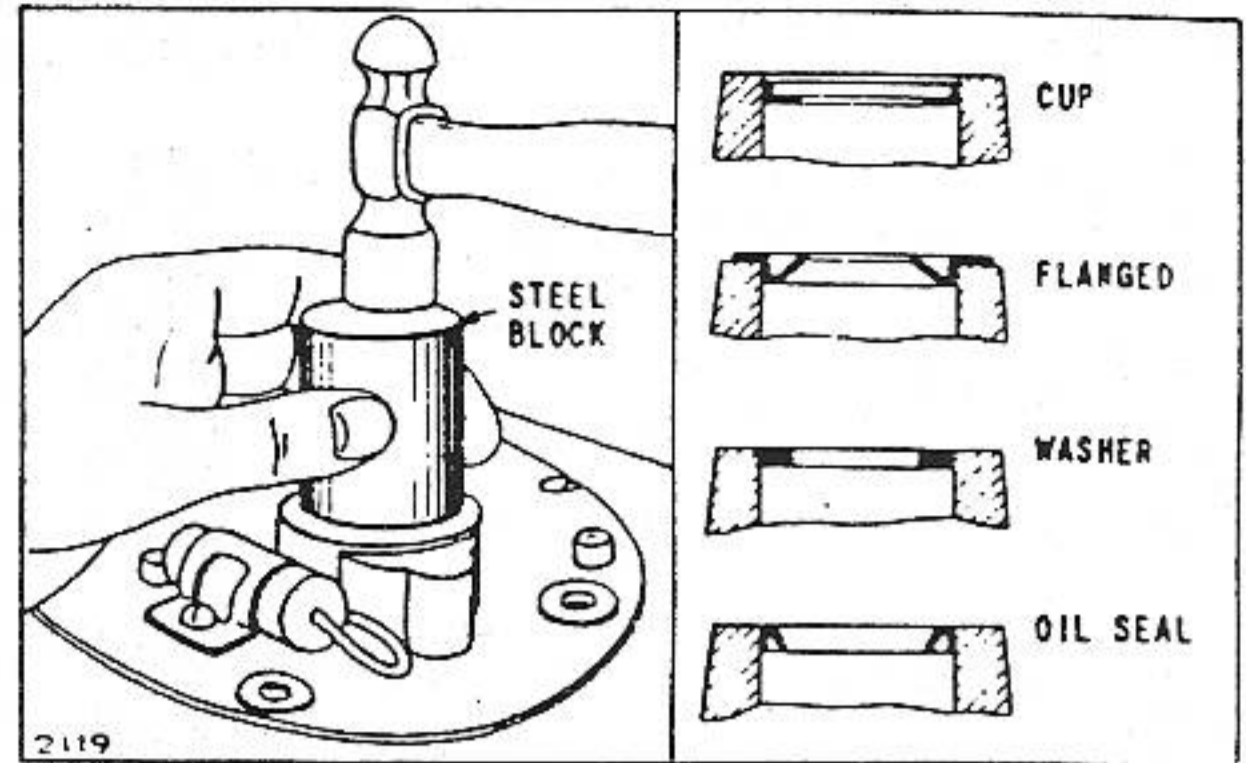


FIG. 164—BEARING OIL RETAINERS

**To Replace Oil Retainer Ring or Oil Seal**

To remove, pry out the old retainer ring with a screw driver.

The cup type is assembled with the edges up. The flanged type can be assembled only with the flange up. The washer type can be assembled with either side up.

The oil seal is assembled with the sharp edge of the leather or rubber down toward the inside of the engine. Rub leather oil seal with "Lubriplate" or equivalent before assembling. Place the retainer ring in the counterbore and either press or drive it into place. Tool No. 69282-T1 can be used where the retainer ring is driven flush. Fig. 164. There should be an air gap of .010" between the cup type and the flange type and the crankshaft journal. If not, file the retainer ring. Do not file the washer type.

**To Protect Oil Seal While Assembling to Engine**

Wrap a piece of cardboard around the power takeoff portion of the crankshaft. The cardboard should be cut to size so that the ends butt and do not overlap. Tape joint with scotch tape. Wrap successive layers around each other until a sleeve is built up that is just a few thousandths larger than the bearing journal. Wrap the last layer with scotch tape. Fig. 165, Ill. 1.

(See Following Page)

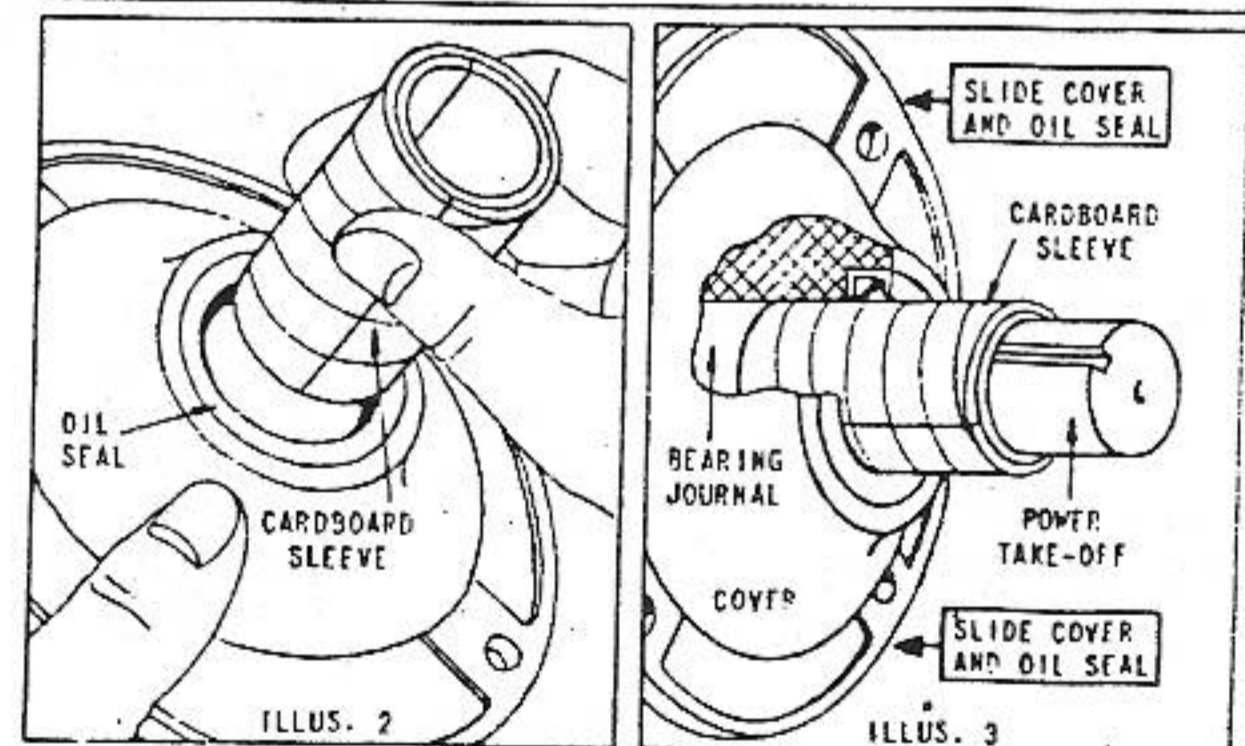
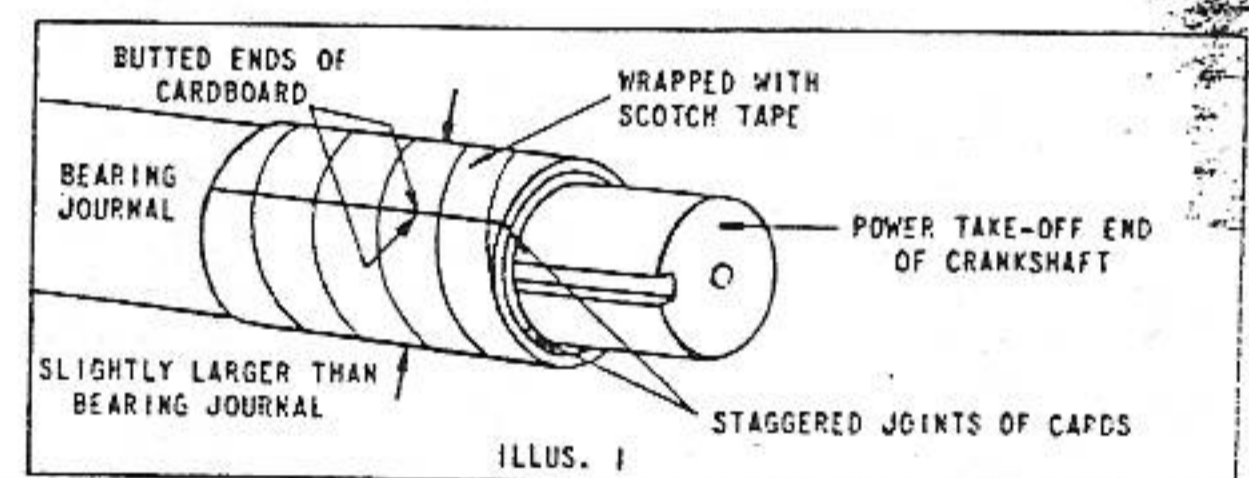


FIG. 165—PROTECTING OIL SEAL

another free manual from www.searstractormanuals.com

To assemble the oil seal and crankcase cover, oil the sleeve and place it in the oil seal from the outside of the oil seal. Fig. 165, Ill. 2. Guide the power takeoff portion of crankshaft into the sleeve and push the crankcase cover into place. The sleeve will stop when it contacts the bearing journal and will allow the oil seal to slip onto the journal without damage to the seal. Fig. 165, Ill. 3.

#### Model 8 and 2" Bore Engines

On engines with plain main bearing on the power takeoff side, the oil seal should protrude  $1/16''$  from the cylinder boss. Fig. 166.

On engines with ball type main bearing, the oil seal should be pressed in  $3/16''$  from the face of cylinder boss. Fig. 166.

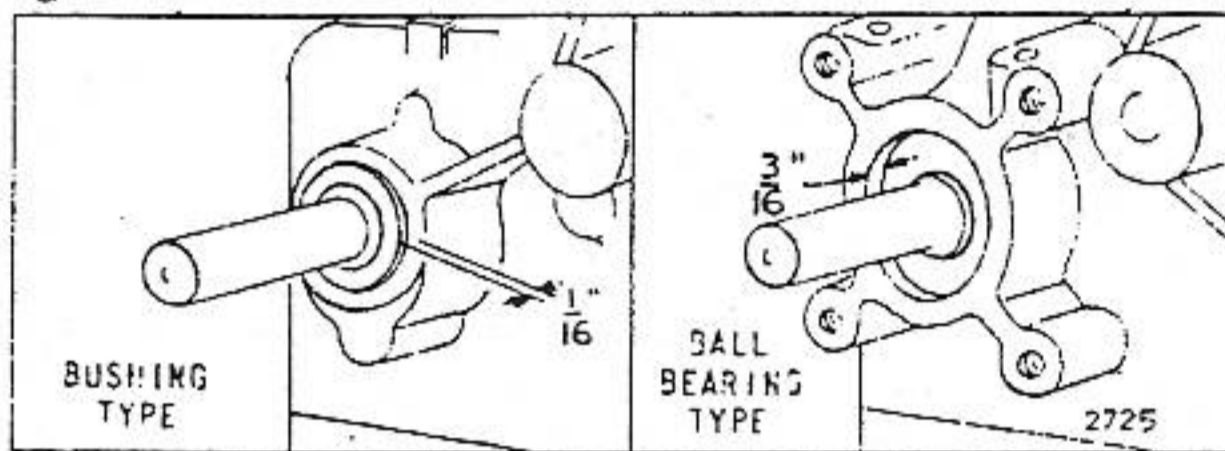


FIG. 166—OIL SEAL LOCATION

#### Models A-B-K-Z-ZZ

When replacing the oil seal on magneto plates with a raised boss on the outer end of the bearing boss (Fig. 167, Ill. 2), it is important that the oil seal be properly seated to prevent leaking or turning loose.

First grind a chisel or old screw driver as shown in Fig. 167, Ill. 1. Then inspect the raised boss as shown in Ill. 2. There will be two or three places where the boss has been peened or staked in. With the sharp edge of the chisel against the oil seal, drive these back as shown. Then with a sharp pointed scraper, scrape all burrs away until the counterbore is round and smooth. Fig. 167, Ill. 3. This is to permit the new oil seal to be inserted without distortion. Remove the old oil seal with a screw driver.

Drive in the new oil seal until it stops against the shoulder in the counterbore. A piece of pipe or rod, slightly smaller in diameter than the oil seal, should be used as a driver. Then use the chisel to stake orpeen a portion of the boss in three evenly spaced places. Fig. 167, Ill. 4. This is to prevent the oil seal from working out. Do not stake so deep that oil seal is distorted.

NOTE: If the magneto plate is so worn that the oil seal is loose in the counterbore, a new magneto plate must be used.

### BALL BEARINGS

Discard old bearing if it is rough or worn. To remove, place crankshaft in arbor press as shown in Fig. 168.

To install, heat bearing in boiling oil or water. Be careful that bearing does not rest on bottom of the pan in which it is heated. Place crankshaft in vise with drive side up. When bearing is quite hot it will become a slip fit on the bearing journal. Grasp bearing with the oil seal down and thrust it down on the crankshaft. Fig. 169 The bearing will tighten on shaft while cooling. Do not quench. Oil immediately if bearing had been heated in water.

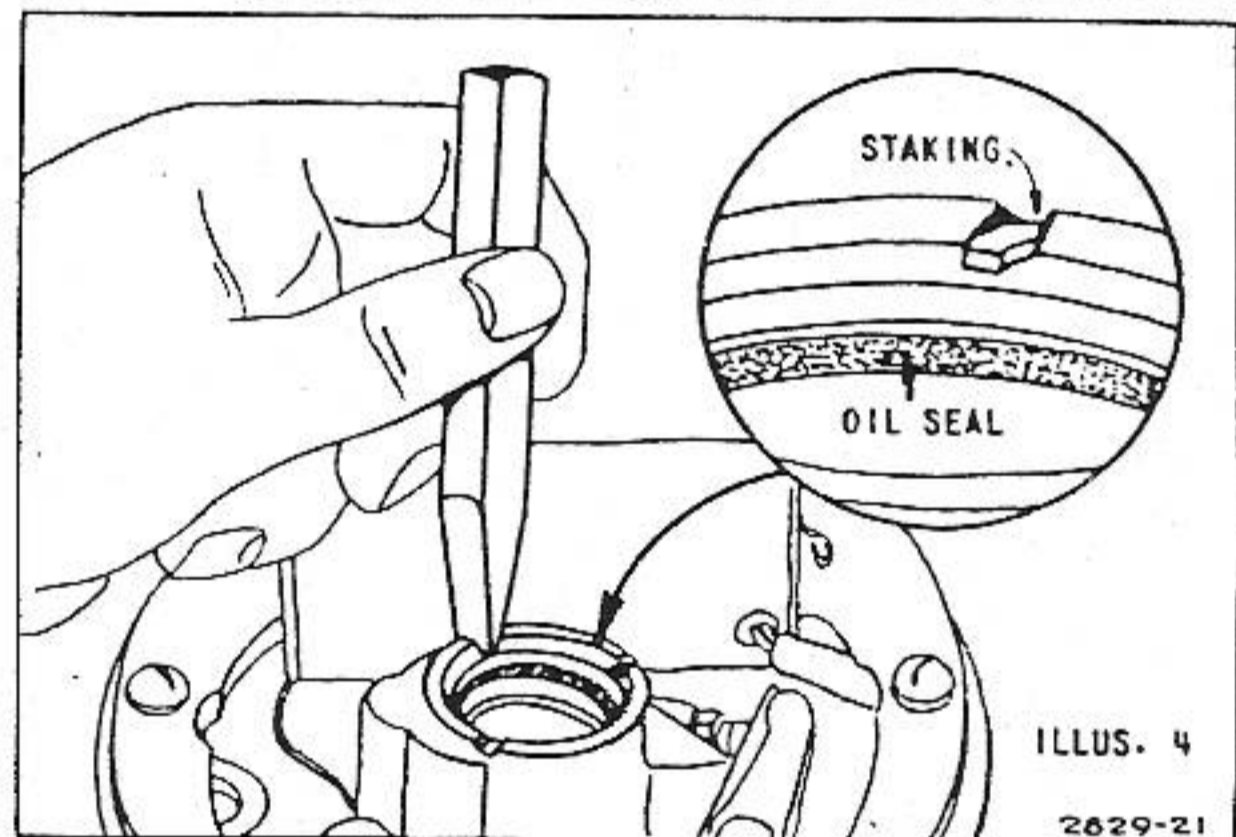
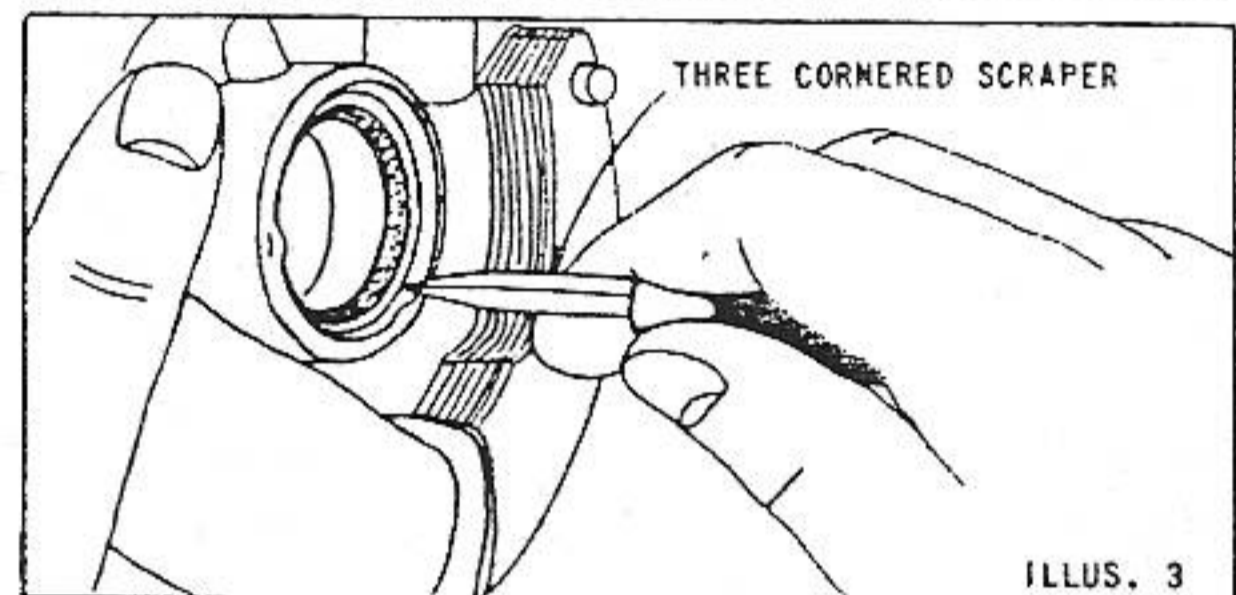
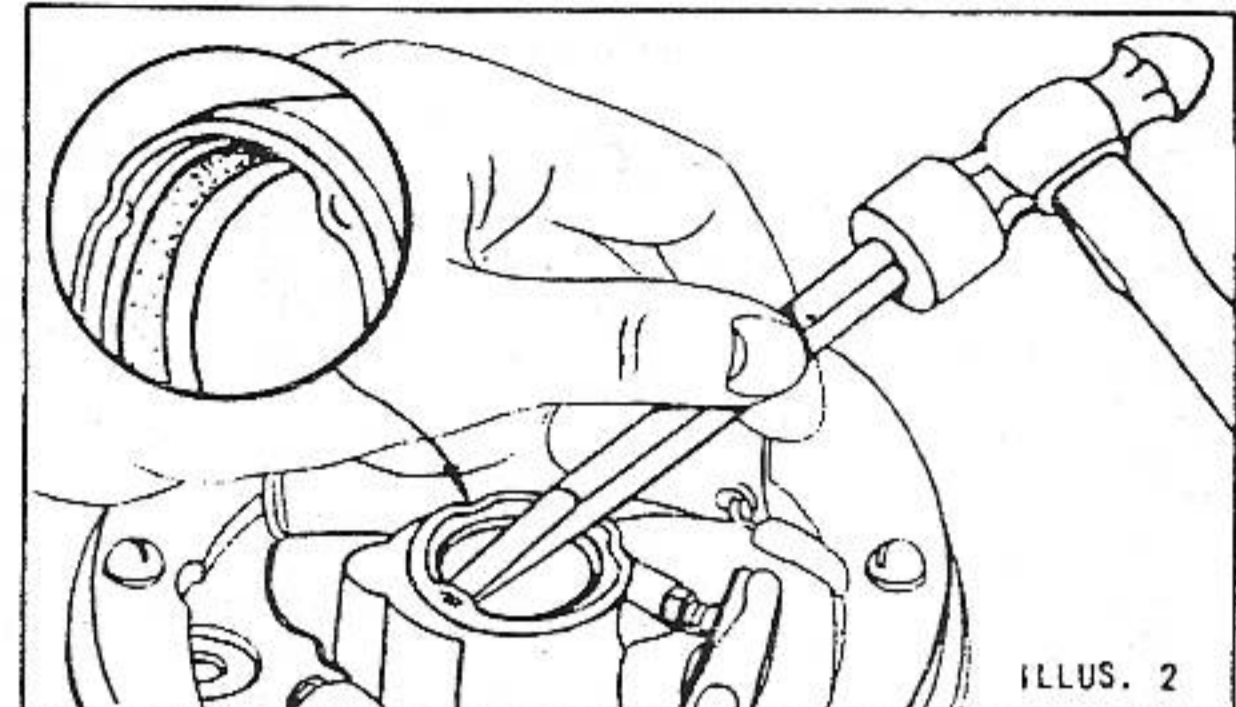
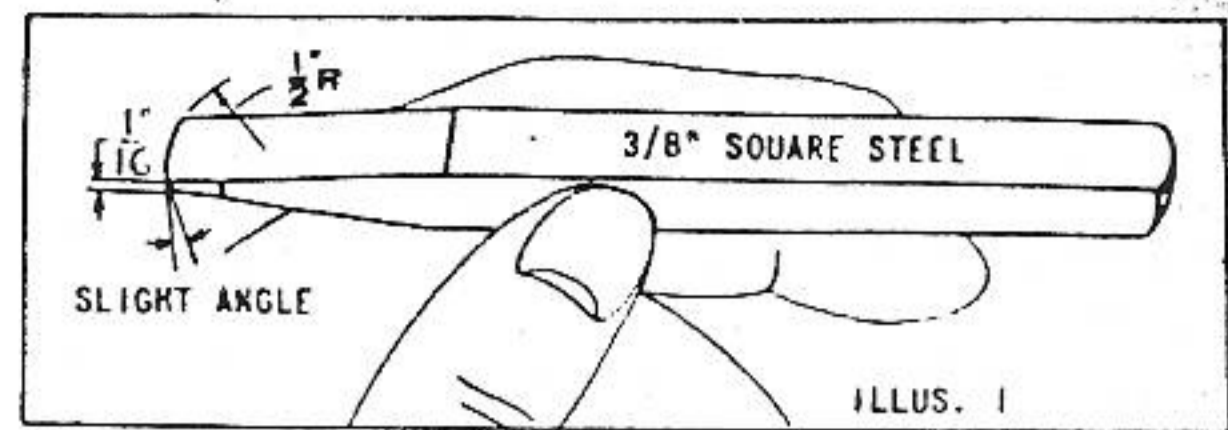


FIG. 167—REMOVING & REPLACING OIL SEAL

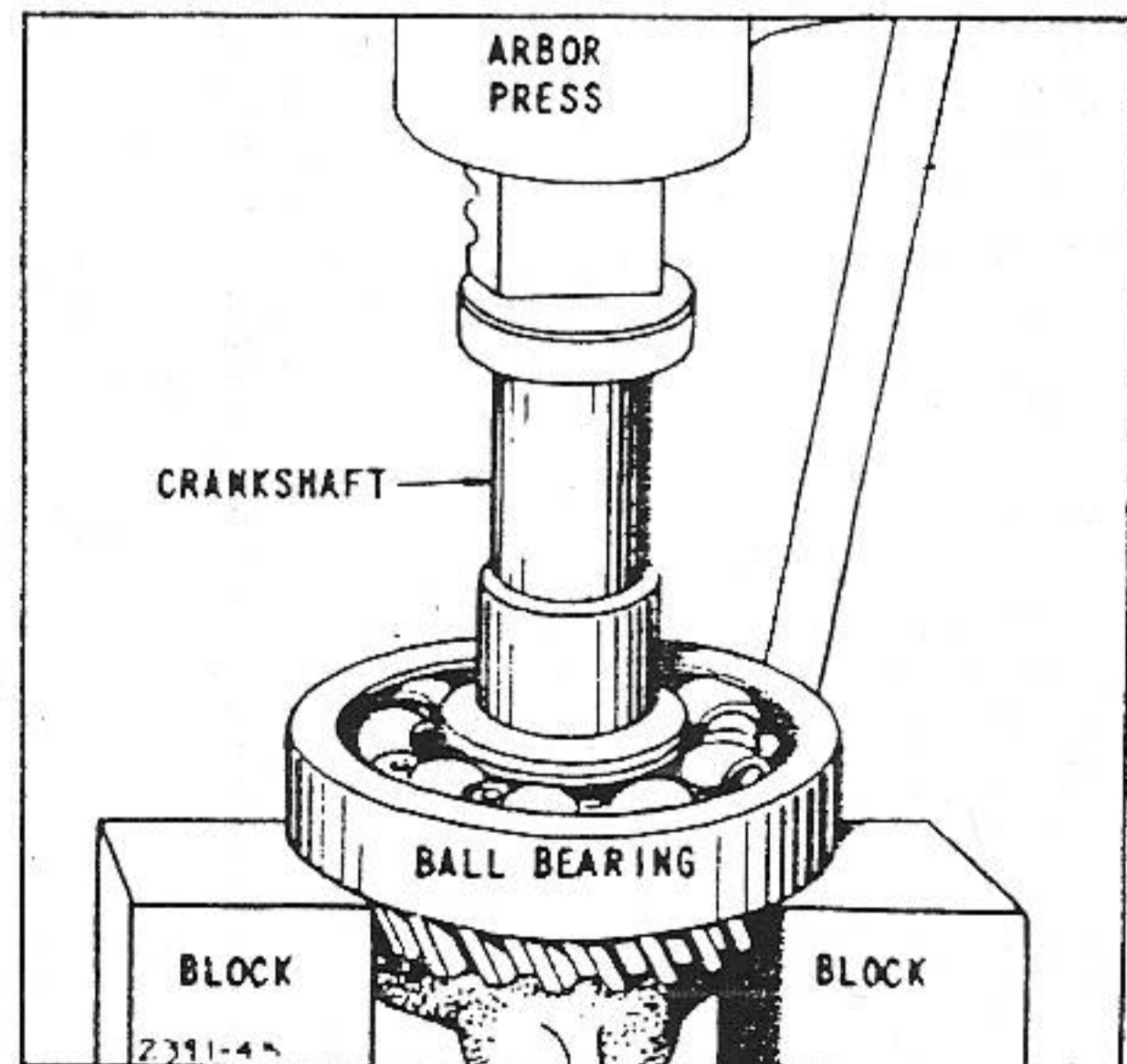


FIG. 168—REMOVING BALL BEARING

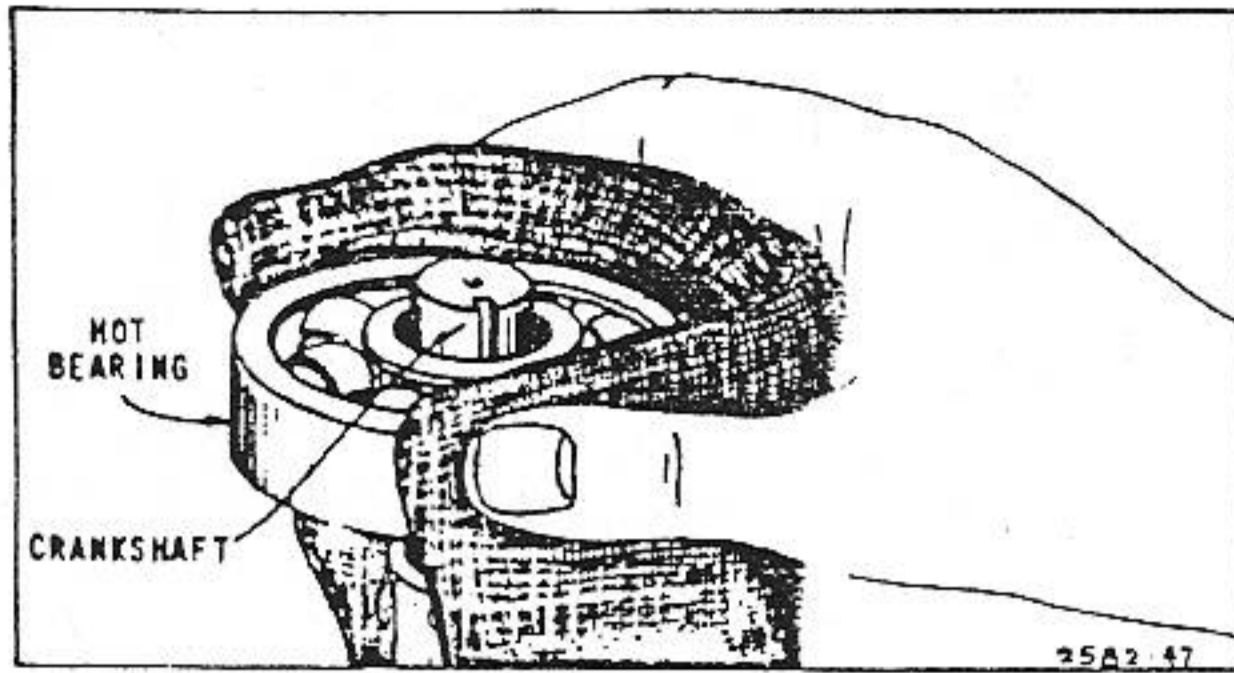


FIG. 169—INSTALLING BALL BEARING

**CAM GEAR BEARINGS**

**Model PB**

(See Chapter 6 on removal of cam gear.) The main bearings on Model PB are replaced as in the preceding instructions, but this model has cam gear bearings which may also be repaired.

Use a Plug Gauge No. 67029-T2 for cam bearing on magneto side, inserting it from drive side as shown in Fig. 170. Use Plug Gauge No. 69265-T2 for both cam and main bearing on drive side. Install new bearing same as main bearing.

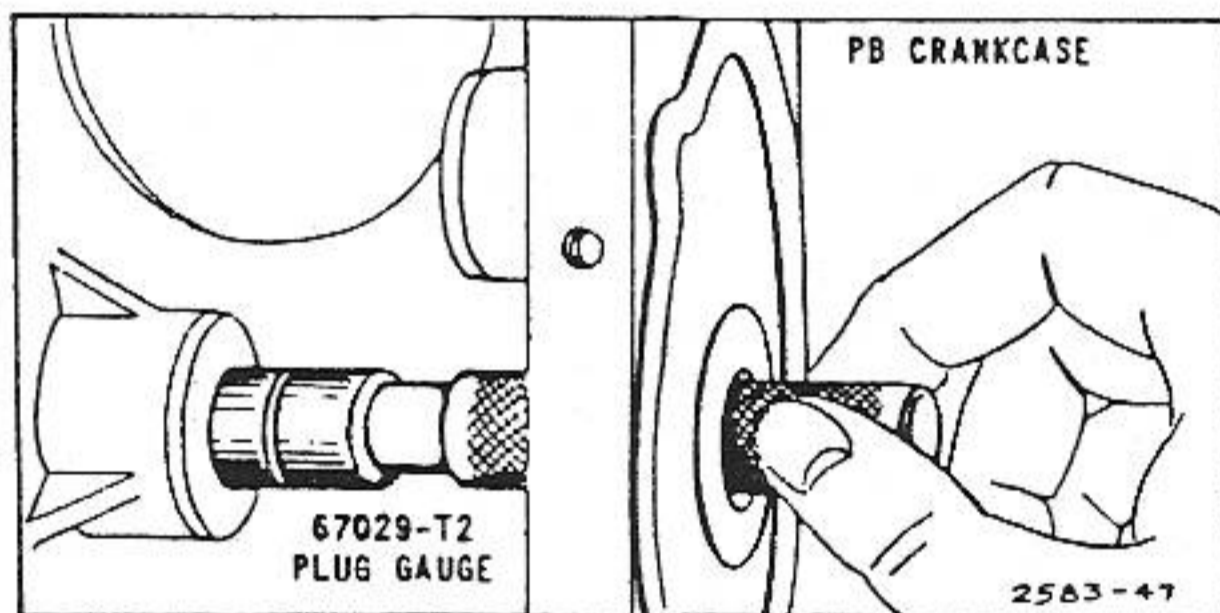


FIG. 170—GAUGING MODEL PB CAM BEARING

To ream use fixture No. 13A18-T30. This fixture is necessary in order to maintain the center-to-center distance of the cam and crankshaft gears so they will mesh properly. Put fixture in place (Fig. 171) with short leg inside crankcase. Line it up with the plug through the main bearing. Insert Reamer No. 67029-T1 from drive side and ream until reamer strikes the magneto plate. Then remove fixture and magneto plate and finish reaming.

NOTE: Tools No. 13A18-T30, No. 67029-T2, No. 69265-T1 are no longer available. If you do not have these tools in your kit, the crankcase must be sent in to the factory for reaming of cam gear bearings.

CAUTION: Always turn reamer clockwise even while removing it from the bearing. Keep a steady pressure on the reamer to eliminate chatter. Handle reamer with utmost care. The slightest nick on a reamer will ruin any bearing on which it is used.

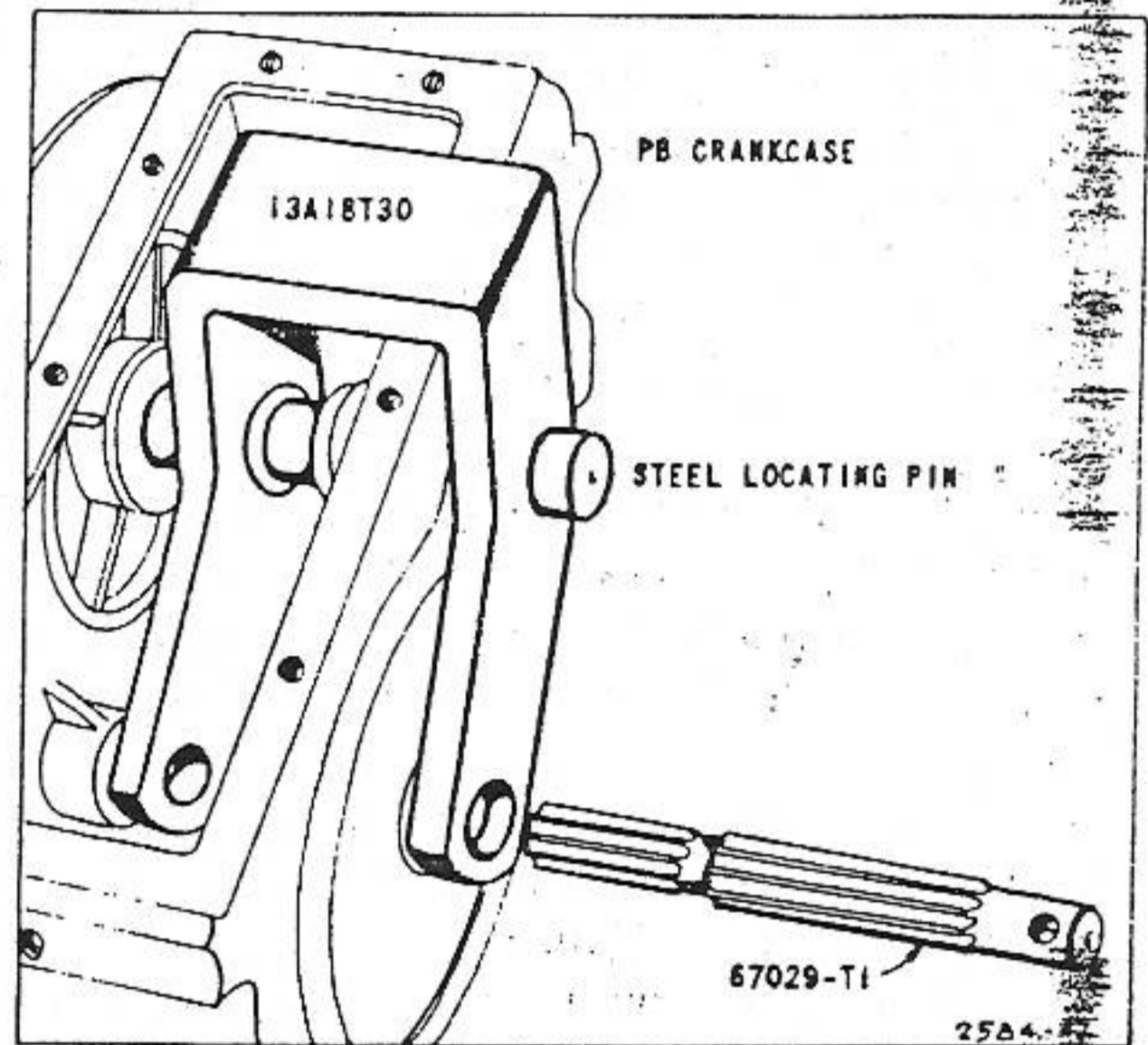


FIG. 171—REAMING MODEL PB CAM BEARING

## OIL SYSTEMS

Briggs & Stratton engines are lubricated by one of three methods:

1. Splash System
2. Constant Level Splash System
3. Ejection Pump System

Both splash systems use the movement of the connecting rod to spray oil to all the surfaces requiring lubrication. A dipper which is either a projection on the bottom of the rod cap, or an extension on one of the cap screws, dips into the oil on each revolution of the engine, splashing the oil to all the internal parts of the engine.

In the Splash System, the dipper dips into the oil reservoir in base of engine. It has no pumps or moving parts. Fig. 172.

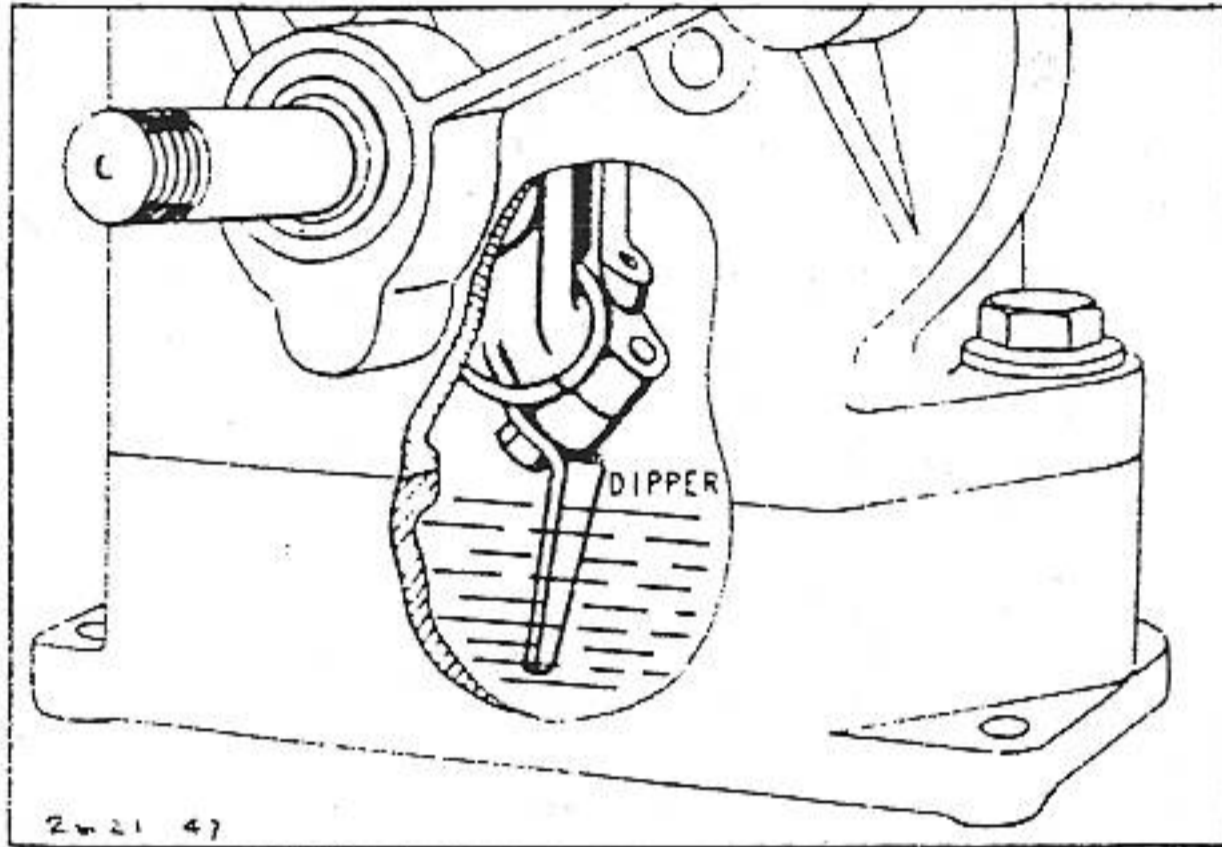


FIG. 172—SPLASH SYSTEM

The Constant Level Splash System consists of a trough into which the rod cap dipper plunges. The trough is filled by a pump actuated by an eccentric on the cam gear and thus a constant oil level is maintained in the trough, even though the oil level in base may vary. Fig. 173.

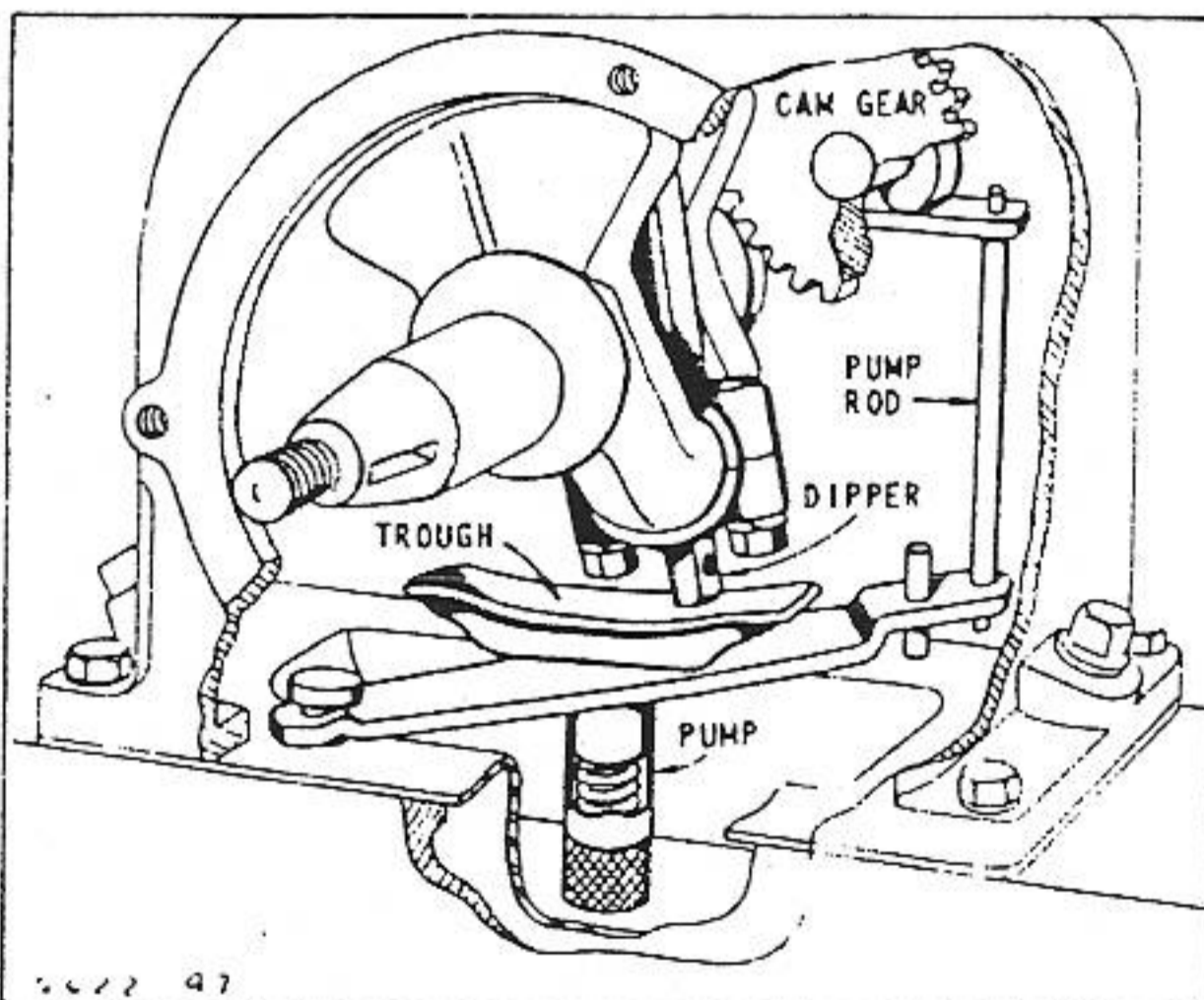


FIG. 173—CONSTANT OIL LEVEL SYSTEM

The Ejection Pump System utilizes a pump from which oil is squirted upward into internal engine parts. The pump is actuated by an eccentric on the cam gear. The movement of the rod and crankshaft also helps throw oil to all internal parts of the engine. Fig. 174.

TABLE NO. 22 - OIL SYSTEM GUIDE

| ENGINE MODEL                   | * TYPE OF OIL SYSTEM | SEE ARTICLE NO. |
|--------------------------------|----------------------|-----------------|
| A - Before Serial No. 180755   | 3                    | 1               |
| A - After Serial No. 180755    | 1                    | **              |
| B - Before Serial No. 185186   | 3                    | 1               |
| B - After Serial No. 185186    | 1                    | **              |
| FH                             | 2                    | 2               |
| FI                             | 2                    | 3               |
| FJ                             | 2                    | 4               |
| H                              | 1                    | **              |
| I-IBP                          | 3                    | 5               |
| I - After Serial No. 303000    | 1                    | **              |
| K                              | 3                    | 6               |
| ***L                           | 1                    | 9               |
| M                              | 2                    | 4               |
| N - Type No. 205000 To 205499  | 3                    | 5               |
| N - Type No. 205500 To 205999  | 3                    | 7               |
| N-NS - After Serial No. 305000 | 1                    | **              |
| PB                             | 2                    | 8               |
| Q                              | 2                    | 4               |
| R                              | 2                    | 4               |
| RC-RH-RL                       | 3                    | 6               |
| ***S                           | 1                    | 9               |
| ***T                           | 1                    | 9               |
| U                              | 3                    | 5               |
| W                              | 3                    | 6               |
| WI (5 Digit)                   | 3                    | 5               |
| WI (6 Digit)                   | 1                    | **              |
| ***WM                          | 1                    | 10              |
| WMB                            | 1                    | **              |
| WMI                            | 3                    | 5               |
| Y                              | 1                    | **              |
| Z                              | 3                    | 6               |
| ZZ - Before Serial No. 292883  | 3                    | 6               |
| ZZ - After Serial No. 292883   | 1                    | **              |
| 9-14-23                        | 1                    | **              |
| 5-6-8                          | 1                    | **              |
| 6H-8H                          | 3                    | 7               |

\* TYPE OF OIL SYSTEMS

- 1 - Splash
- 2 - Constant Level Splash
- 3 - Ejection Pump
- \*\* - Splash System (See Fig. 172)
- \*\*\* - Originally used Type 2. Change to Type 1 when repaired.

All pumps—either ejection type or constant level splash type—should always be tested while engine is being repaired.

This can be done by immersing the pump inlet in oil and working the plunger up and down. The ejection type pump should shoot a jet of oil from the outlet hole. Fig. 174. The constant level splash type should fill the oil trough

with oil. If this does not occur, the entire pump should be thoroughly cleaned, and retested. If it still does not work, it should be replaced with a new one. See Table 22 for the type of oil system used on each engine model.

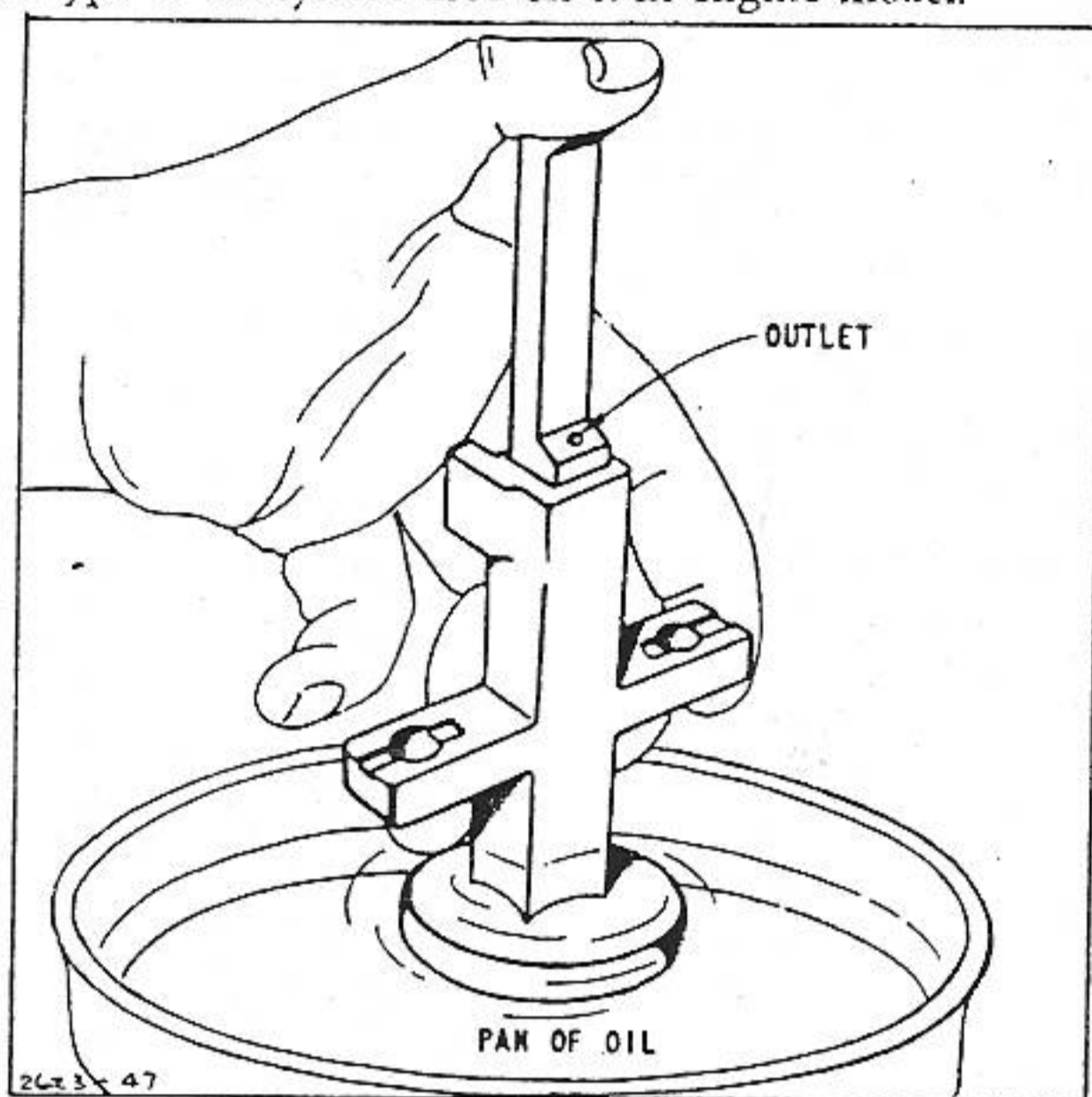


FIG. 174—EJECTION PUMP

### ARTICLE 1—Models A-B

The pump rod is also the plunger on this type of oil pump. Fig. 175.

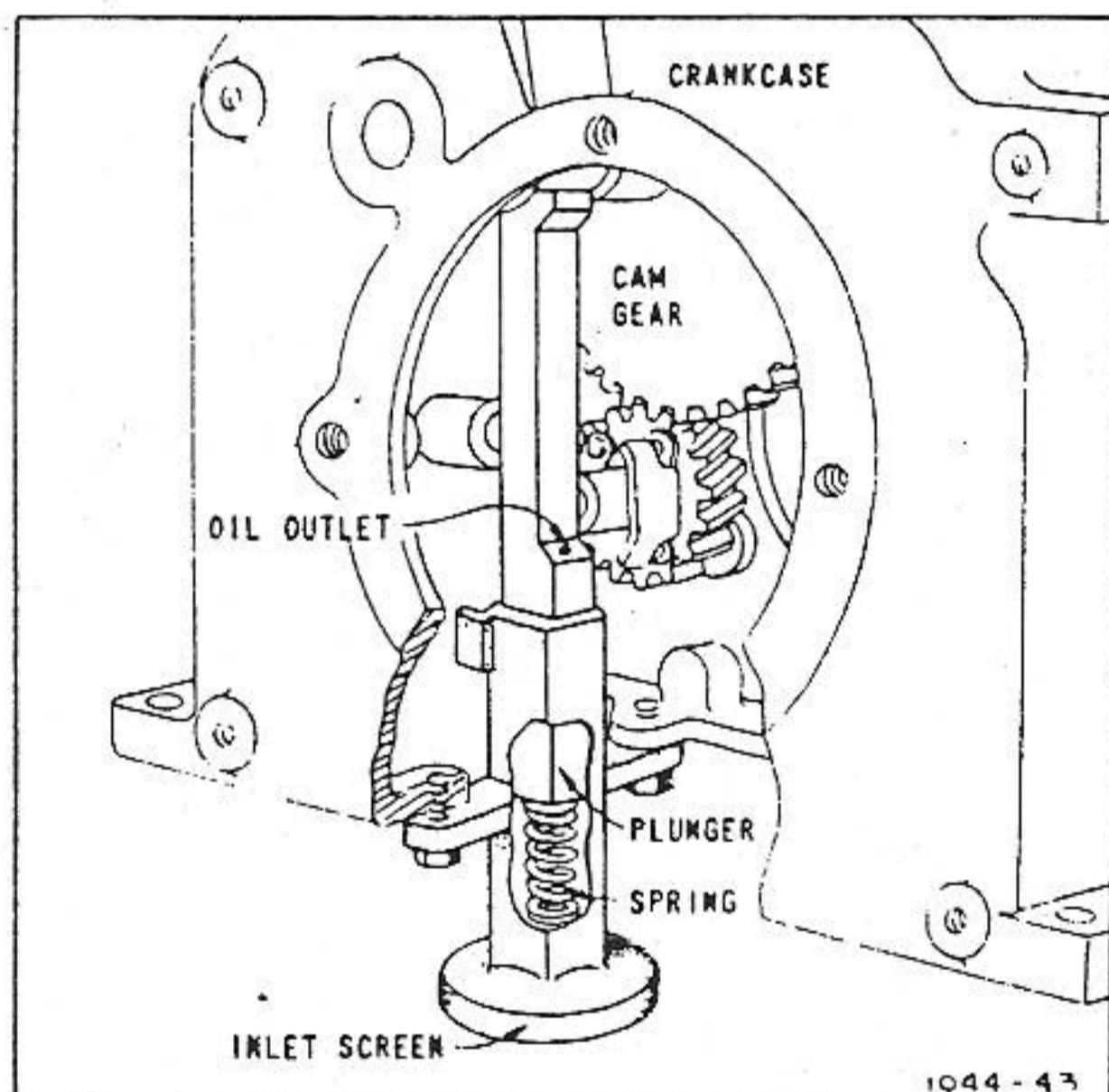


FIG. 175—MODELS A-B PUMP

#### To Remove Pump

Lay engine on its back. Remove the two cap screws which hold the pump to bosses on bottom of crankcase. Take care not to lose plunger or spring. Test and clean pump as explained at the beginning of this chapter. If it does not eject oil at outlet hole it must be replaced.

#### To Assemble Pump

Place spring in pump body. Place plunger in pump with oil outlet hole opposite to boss on top of pump body.

#### To Assemble Pump to Engine

Push plunger down into pump compressing spring. Grasp pump with one hand, the forefinger at oil outlet, holding plunger in. Place pump in crankcase with the oil outlet toward the crankshaft. Tighten cap screws. Check to see that the end of plunger is against the cam gear. Be sure governor crank is between the governor gear and the boss on end of pump body. For old style pump see Fig. 176.

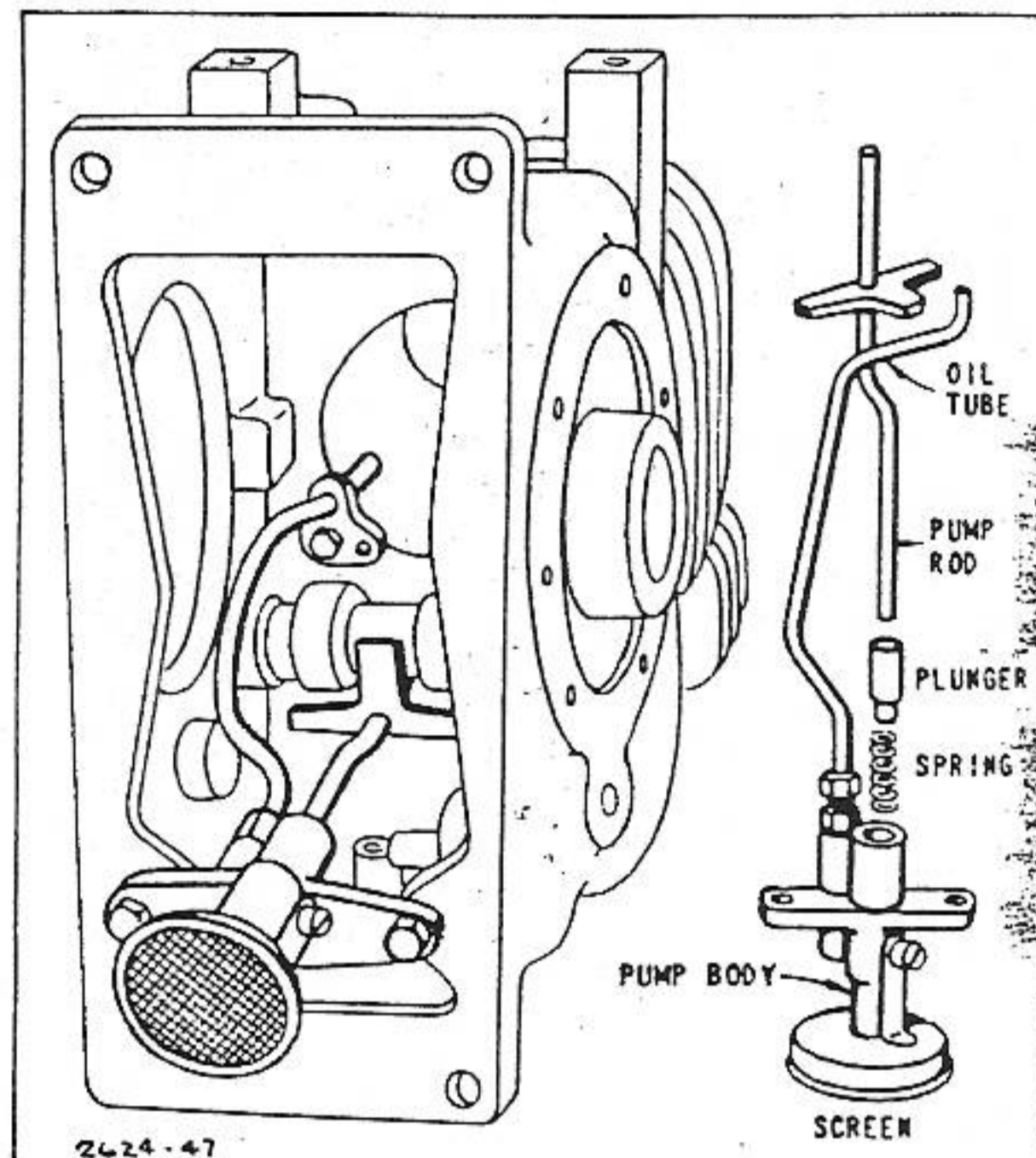


FIG. 176—OLD STYLE MODELS A-B PUMP

### ARTICLE 2—Model FH

This pump is permanently attached to the oil pan which is assembled between the crankcase and the base. The base on this model is the gas tank. Fig. 177.

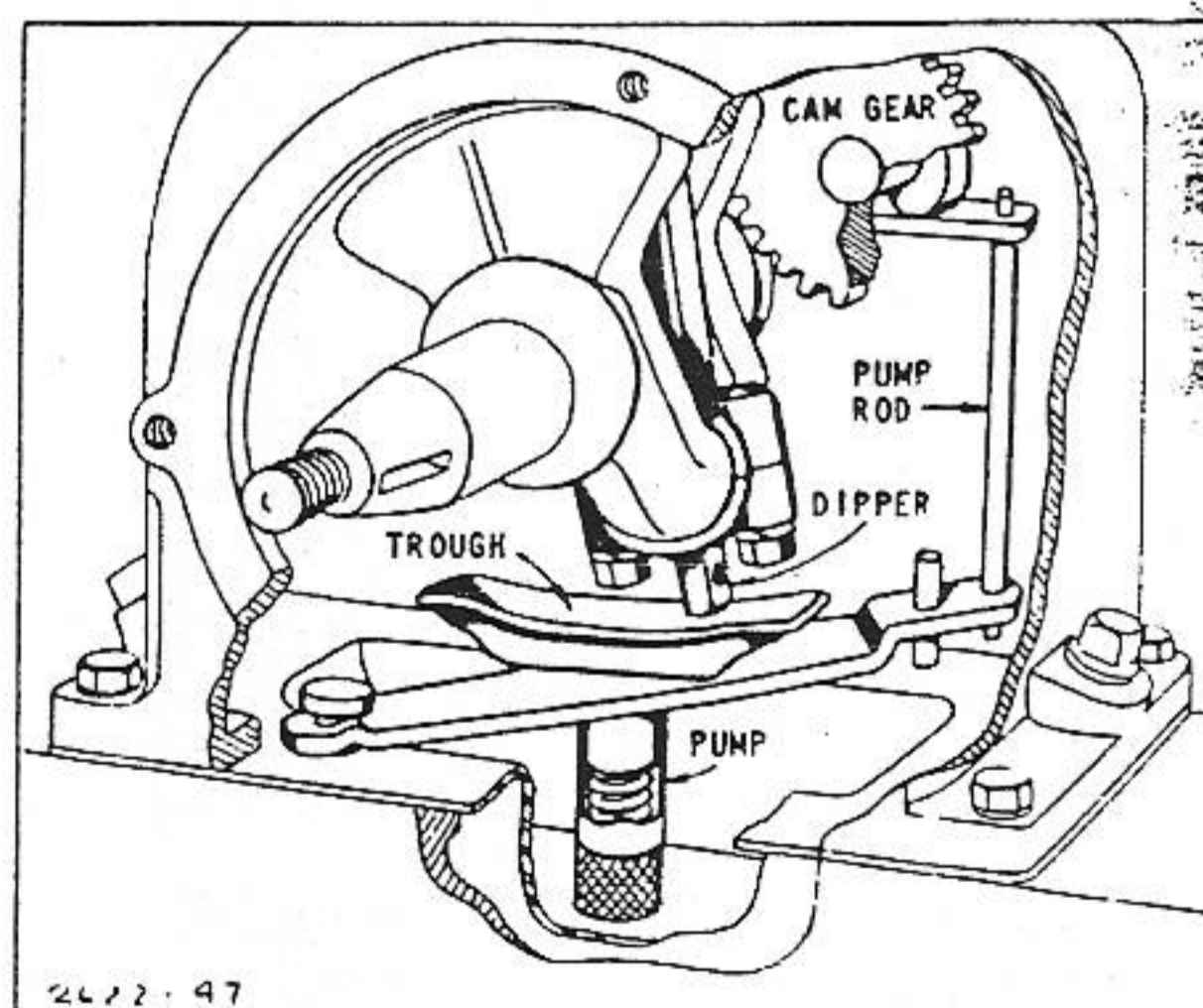


FIG. 177—MODEL FH PUMP

#### To Check Pump

Fill the oil pan with oil to within  $\frac{1}{2}$ " of the top. Work the plunger up and down. If the oil trough fills with oil the pump is working satisfactorily. If not, clean and recheck. If it still does not work, it should be replaced with a new one.

**To Reassemble**

Secure two wooden pegs which fit snugly in the base mounting holes but are small enough to pass through those of the oil pan and crankcase. Invert cylinder. Place pump rod into hole in cam follower. Fig. 178. Assemble gaskets to oil pan and base and place oil pan on crankcase with pump rod in the small hole in pump lever. With wooden pegs in engine base, turn crankcase to upright position, holding the oil pan in place. Lower the crankcase assembly on the base with the pegs guiding it into place. Remove pegs and assemble screws. Fig. 179.

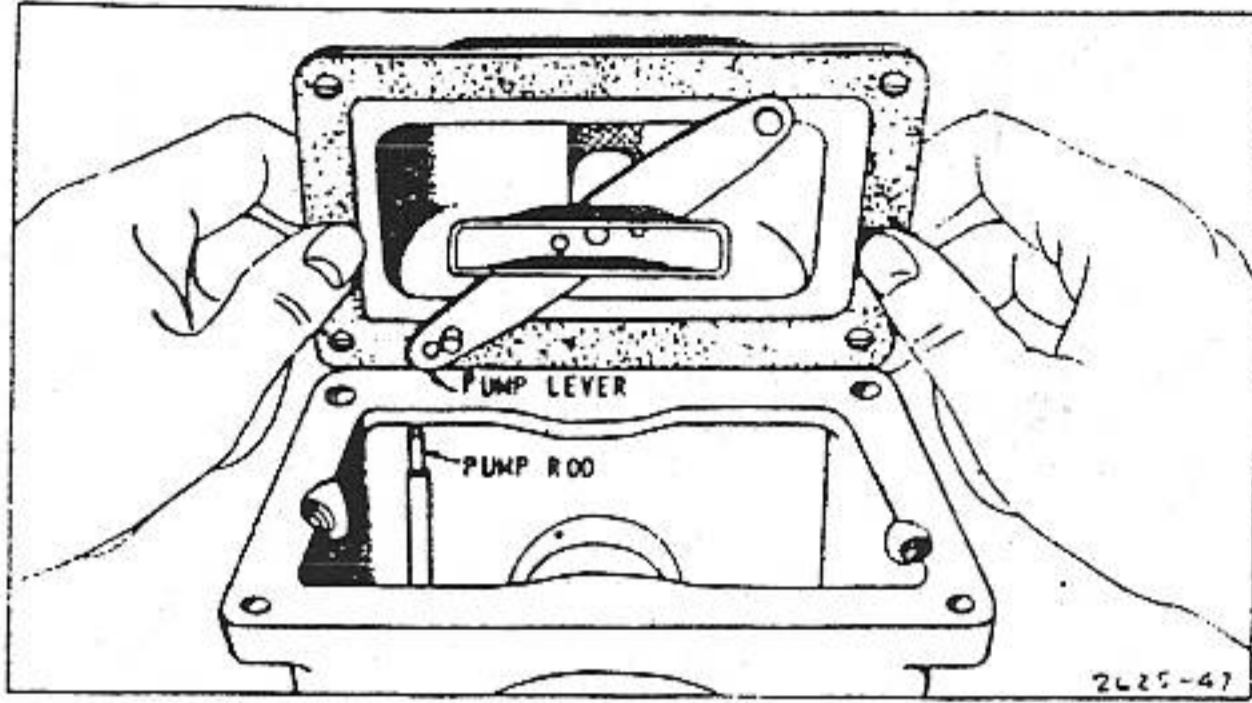


FIG. 178—REASSEMBLING MODEL FH PUMP

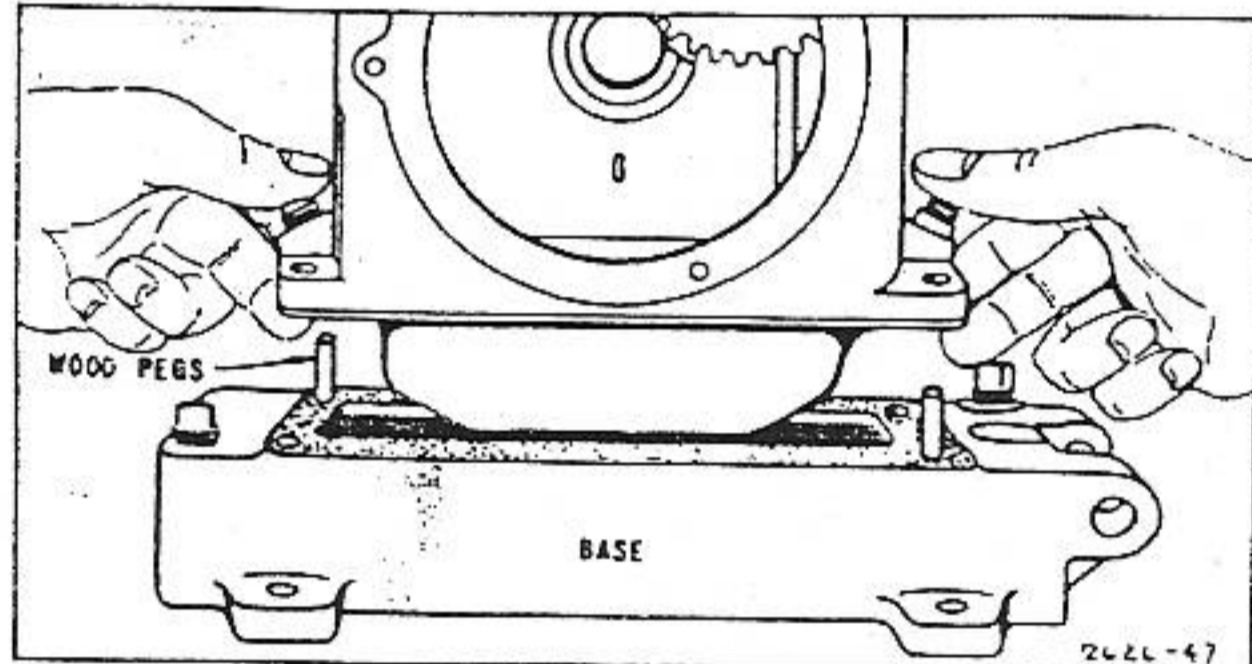


FIG. 179—MOUNTING CRANKCASE MODEL FH

**ARTICLE 3—Model FI**

The pump body and oil trough is a unit assembly, mounted on two bosses in the engine base. Fig. 180.

**To Check Pump**

Fill base with oil so intake is about  $\frac{1}{2}$ " below surface. Insert pump spring, plunger, and rod. Work rod up and down. If trough fills with oil, pump is working. If not, disassemble, clean and reassemble. If trough still does not fill, the pump assembly must be replaced.

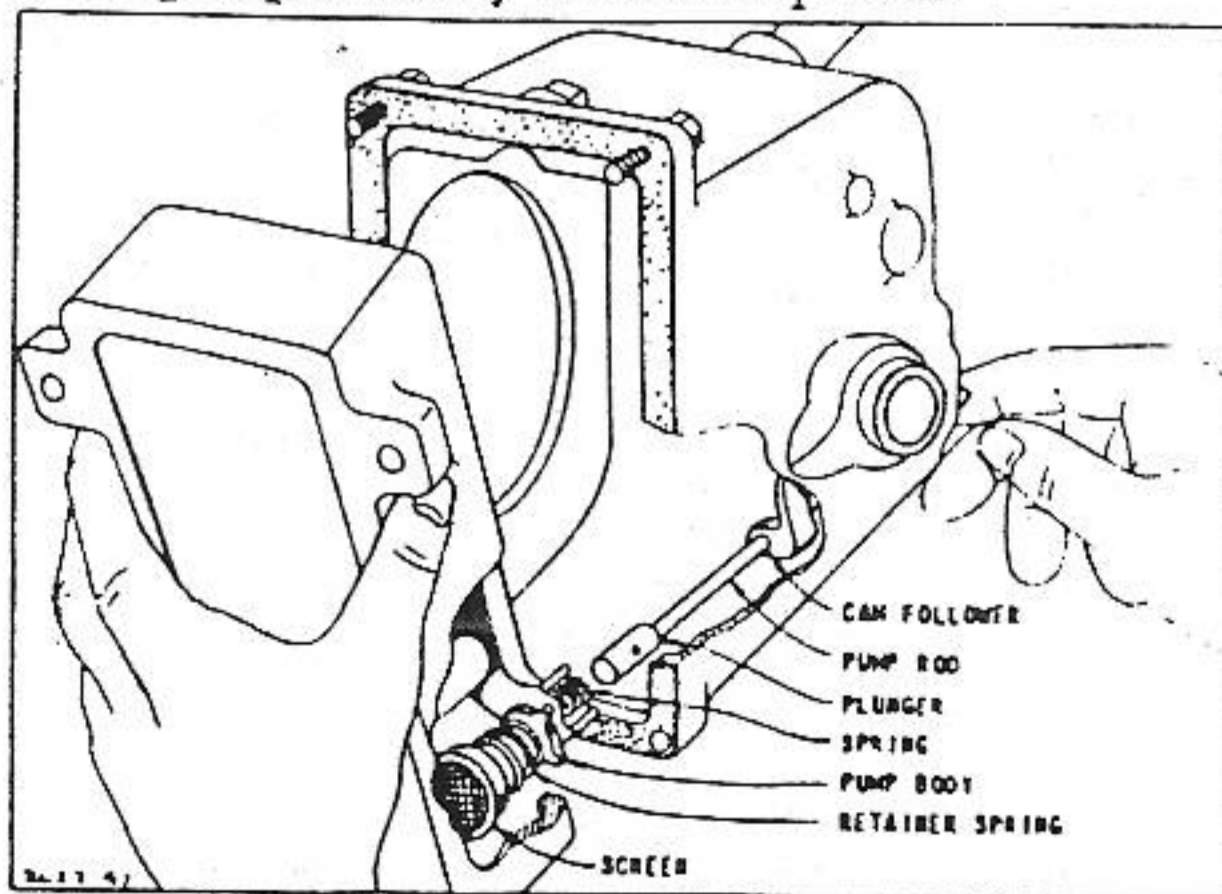


FIG. 180—OIL SYSTEMS MODEL FI

**To Assemble Base to Crankcase**

Lay engine on its side, breather side up. The crankcase should overhang the edge of the bench. Insert the upper base screws in the crankcase mounting holes and hang the base gasket on these screws. Insert the pump rod in the hole of the intake valve cam follower. Place the plunger on the end of the pump rod. Place the base against crankcase so that plunger enters hole in pump body. THE PLUNGER MUST ENTER INTO HOLE IN PUMP BODY. Start upper base screws into base. Hold base firmly against crankcase and set entire assembly upright on the base. Tighten all mounting screws.

**ARTICLE 4—Models FJ-M-Q-R**

Testing and cleaning instructions are the same as for previous trough type pumps.

**To Reassemble**

Insert straight end of pump rod into hole in crankcase until flat tongue rests against cam gear. Place pump spring and plunger in pump body before assembling base to crankcase. Fig. 180. All other instructions are the same as for Models FI

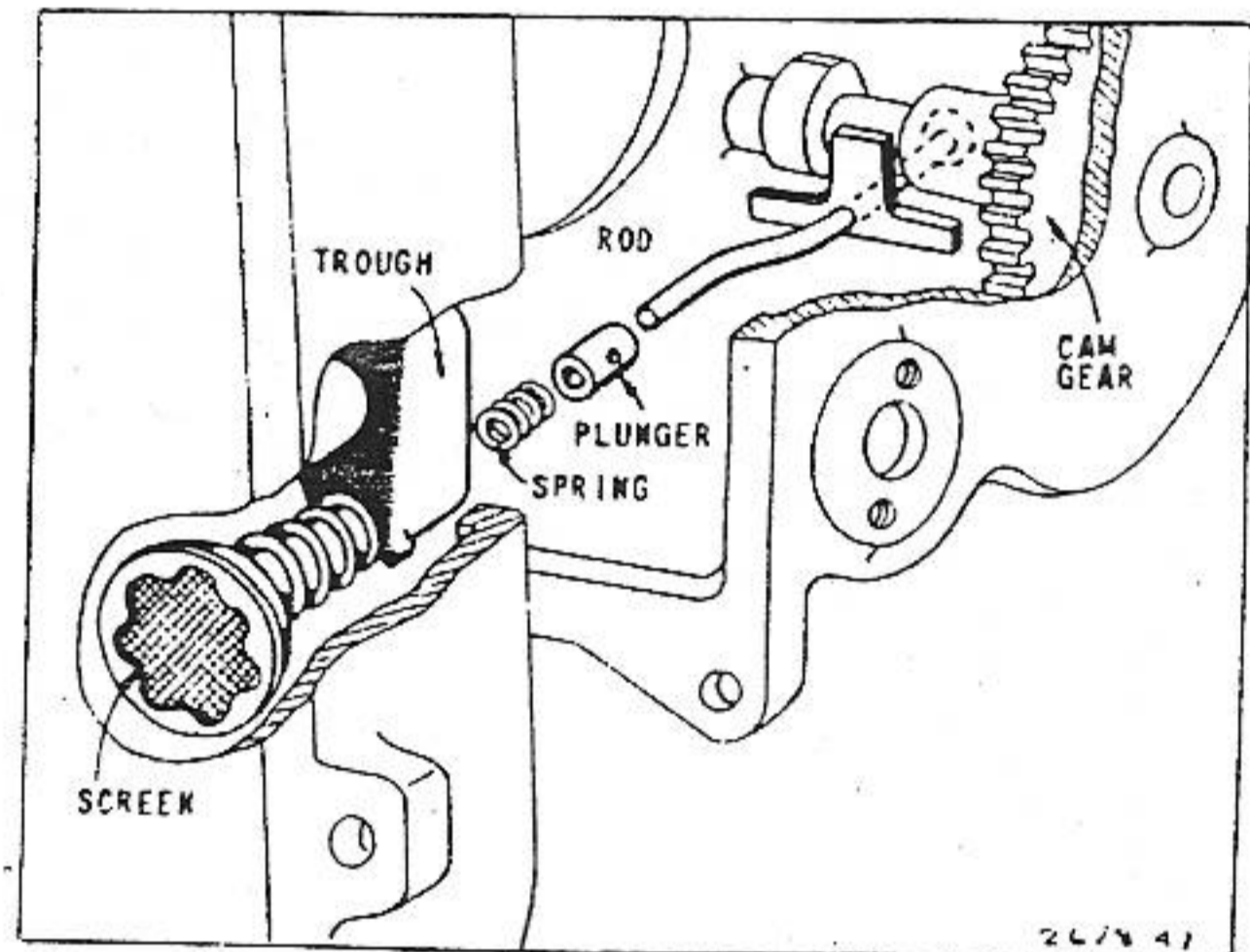


FIG. 181—REASSEMBLING OIL PUMP

**ARTICLE 5—Models I-IBP-N-U-WI-WMI**

Pump can be tested by filling base so that oil is  $\frac{1}{2}$ " over inlet. Push plunger up and down. Oil should squirt from outlet hole. Remove from base by loosening the screws.

**To Reassemble**

Place pump on two bosses which protrude upward from base. Tighten down with screws. Fig. 182. If a baffle plate is used, the screws are longer and the spacers go between the pump and the baffle plate. Fig. 182. Place plunger and spring in place.

Assemble base to crankcase. Two types of bases are used with these pumps—(A) The dowel pin base and (B) the 8-hole mounting base. Assemble as follows:

- A. Insert the dowel pins in the base. Place the base gasket on base. Set the crankcase down into base with dowel pins as guides. Tighten securely.
- B. Lay crankcase on its side. Lift base and put two mounting screws, with lock-washers through the mounting

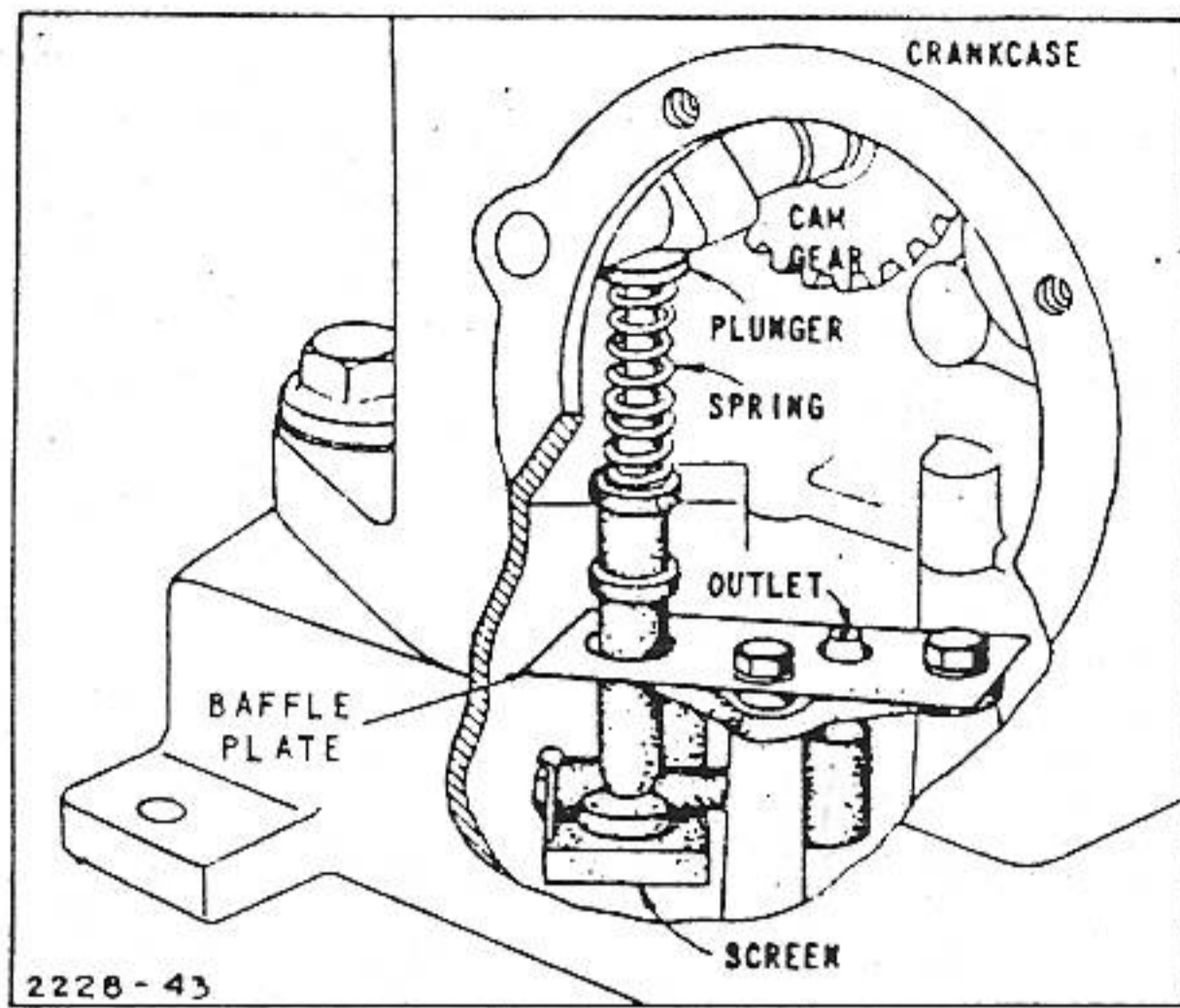


FIG. 182—OIL SYSTEM

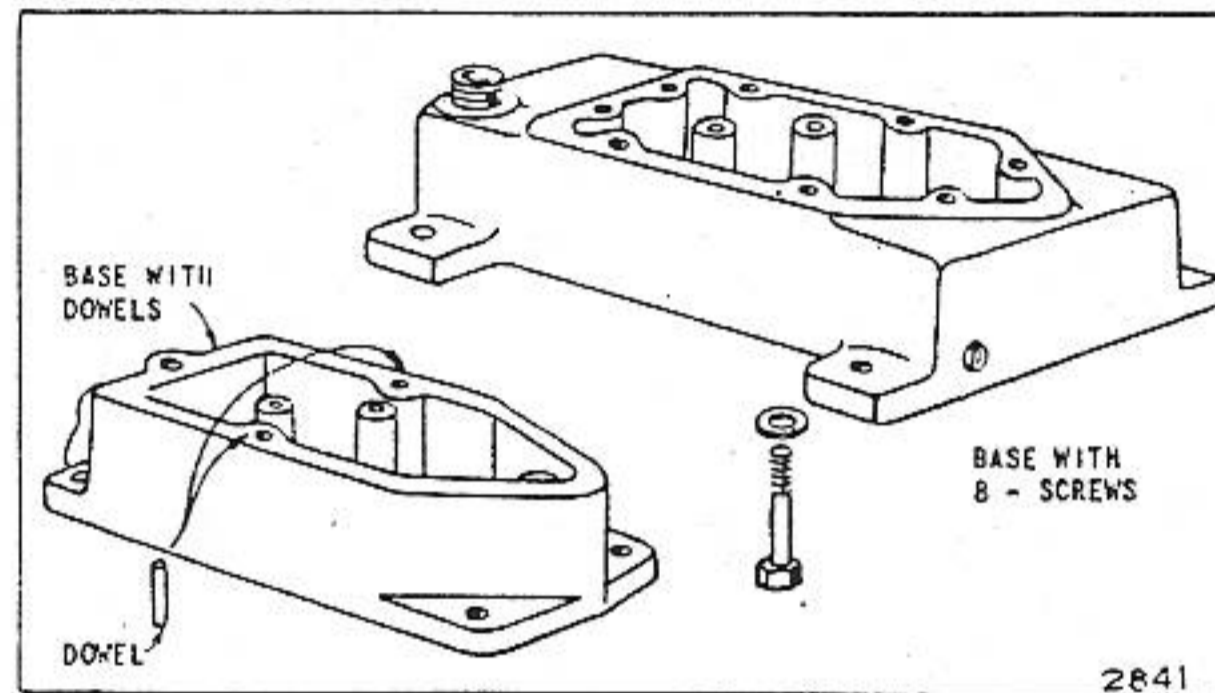


FIG. 183—BASES

holes. Hang base gasket from these screws. Place base against crankcase and turn screws in a few turns. Start the rest of the mounting screws, being sure to align the base gasket. Tighten securely. Fig. 183.

### ARTICLE 6—Models K-R-W-Z-ZZ

Remove pump by removing two cap screws and pull tube gently from retainer. Do not force. Twist pump slightly so tube will not bend.

#### To Test

Place inlet in oil and move plunger up and down. Oil should squirt from outlet at top of tube. If not, follow instructions for cleaning.

#### To Reassemble

Place double end of push rod into two holes in crankcase with flat tongue against cam gear. Insert spring and plunger into pump body, holding plunger in place with forefinger. Place pump into crankcase so that end of outlet tube slides through hole in retainer at top of crankcase. Then allow end of push rod to enter plunger. Do not force. Twist and wiggle pump until it slides into place without bending tube. Fasten into place with cap screws. Fig. 184. The outlet tube should be pointed so as to direct oil against the top of the piston.

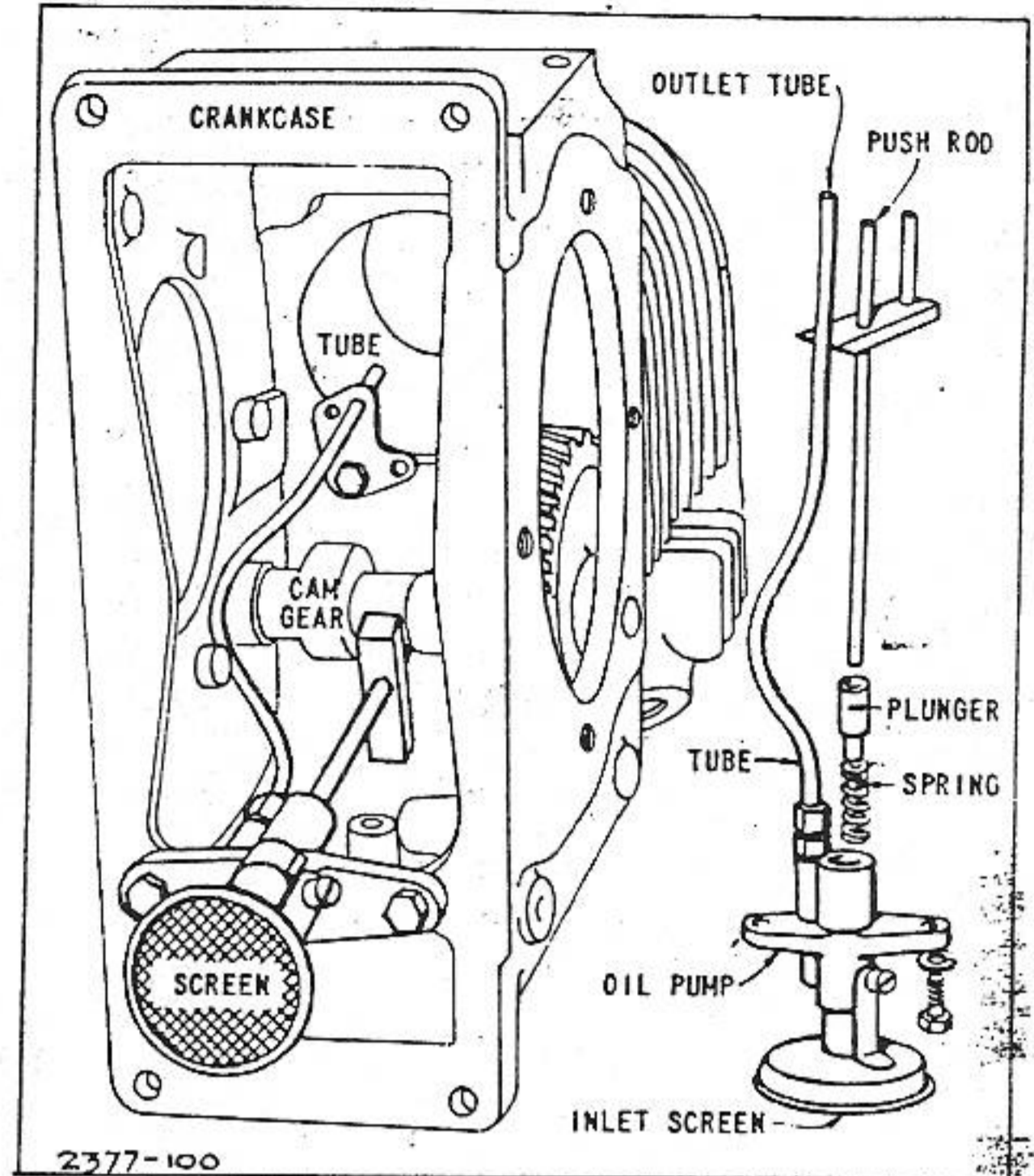


FIG. 184—OIL SYSTEM

### ARTICLE 7—Model N (Type Nos. 205500 to 205999) and Horizontal Type Engines

#### To Test Pump

Fill base with oil so that oil intake is 1/2" under surface. Spin gear rapidly with finger. Oil should squirt from outlet nozzle. Fig. 185, Ill. 2. If not, remove from base and clean thoroughly. Prime pump by squirting several shots of oil into intake hole with an oil can. Fig. 185, Ill. 3. Revolve gear until oil ejects from outlet nozzle. Reassemble pump to base and retest, spinning gear rapidly. If oil still does not squirt from outlet nozzle, replace pump.

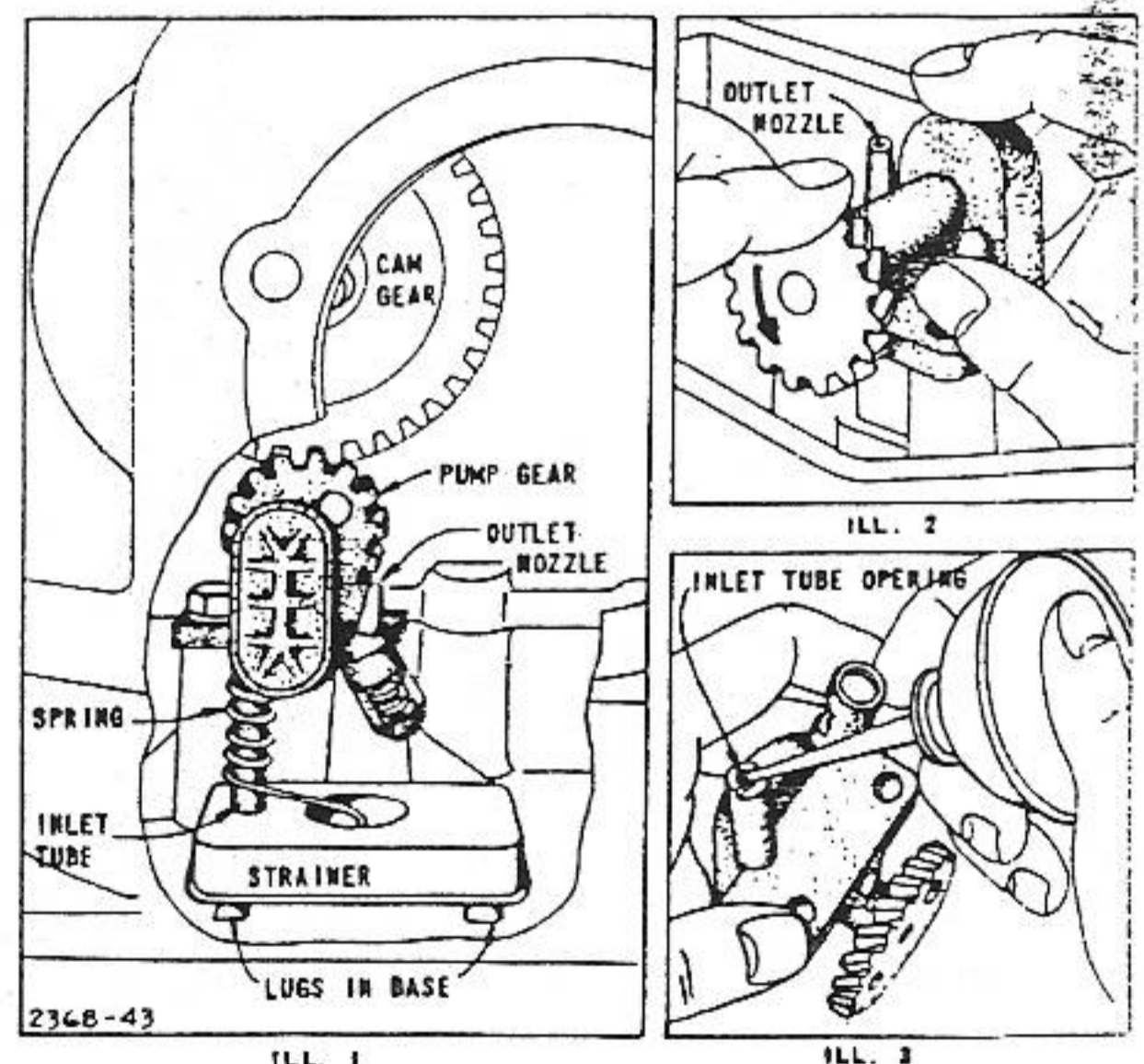


FIG. 185—GEAR TYPE OIL SYSTEM

**To Reassemble Pump**

Place strainer in base on lugs which hold it off the bottom. Assemble spring to pump and insert inlet tube into hole in strainer and long end of spring into dent in strainer. Fasten pump to bosses with cap screws.

On horizontal engines the oil tube extends into the oil sump. Be sure that screen is clean. Fig. 186.

Assemble base and crankcase as in Article 5. Be sure the oil pump gear engages cam gear.

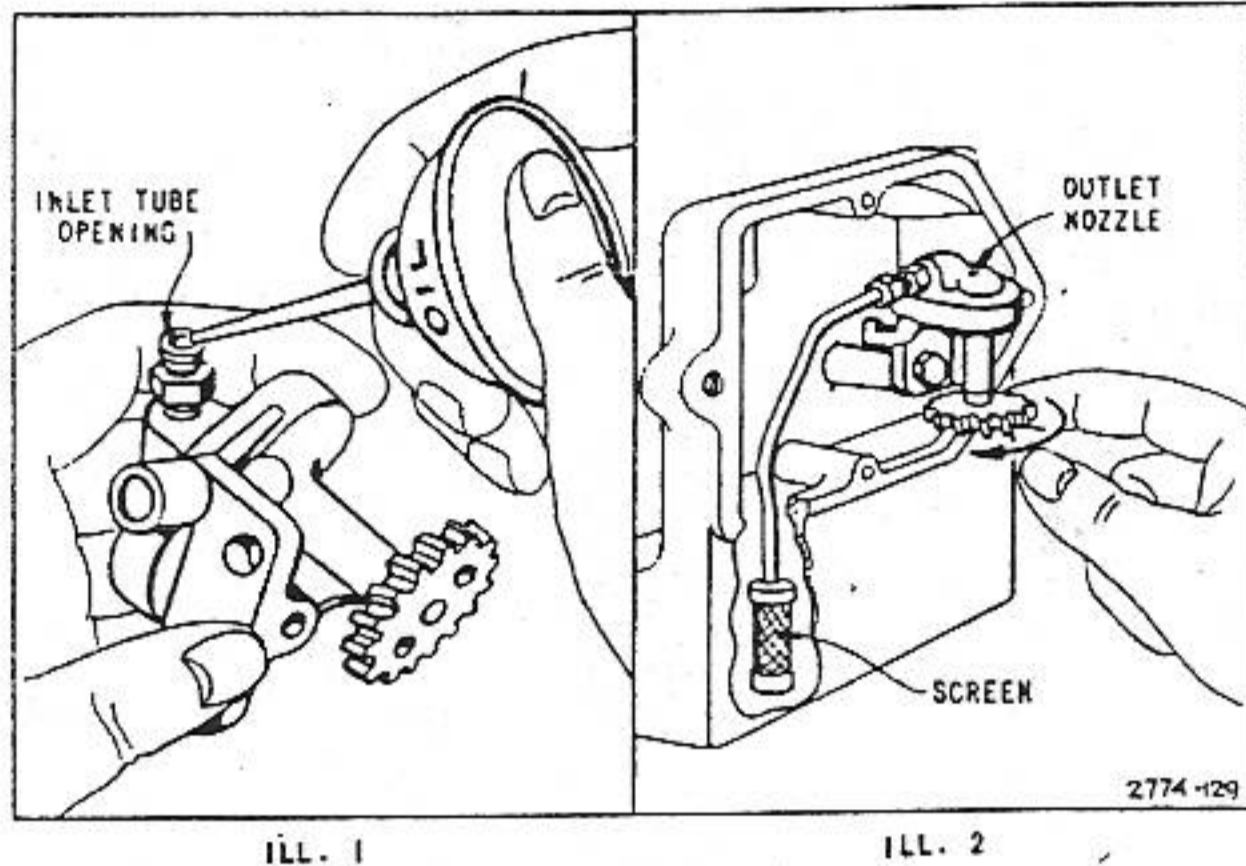


FIG. 186—HORIZONTAL ENGINE OIL PUMP

**ARTICLE 8—Model PB**

This type is similar to the trough type except that an oil pan is used instead of the trough. The oil pump forces the oil from the base up into the oil pan where it is splashed by the connecting rod. Fig. 187

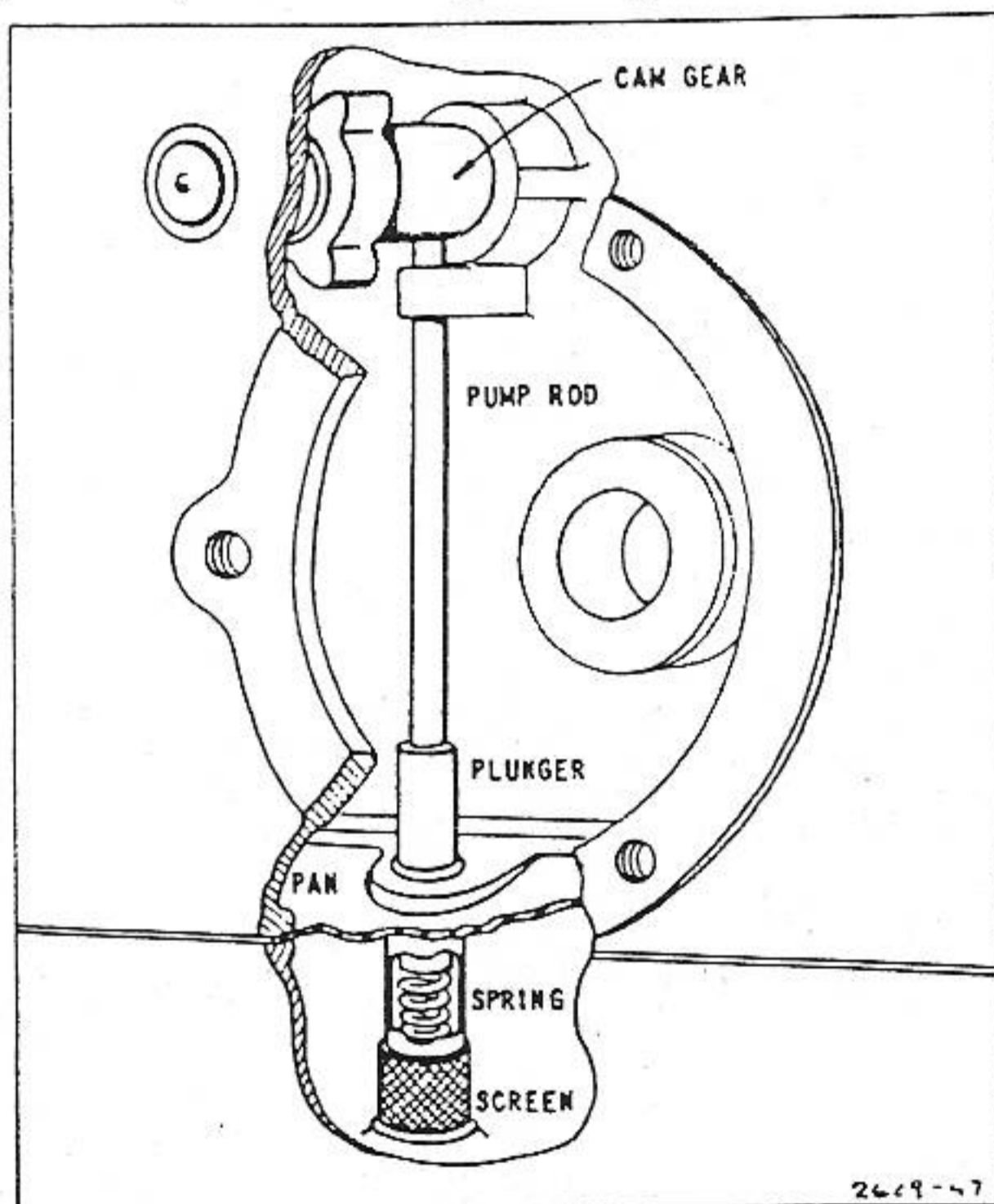


FIG. 187—MODEL PB OIL SYSTEM

**To Test Pump**

Fill base with oil until inlet hole is  $\frac{1}{2}$ " under the surface. Move plunger up and down. Oil pan should fill with oil. If not, soak, clean and retest the pump. Replace if necessary.

**To Assemble**

Lay crankcase on side. Place pump rod in hole in boss and place plunger on end of rod. Put oil pump body in base and place gasket, oil pan and second base gasket on base. Push two base screws into base to hold these parts in place. Assemble base and pan to crankcase taking care to see that pump plunger enters pump body. Turn in base screws to hold in place. Assemble remainder of base screws and tighten securely.

**ARTICLE 9—Models L-S-T**

These models were originally equipped with a constant level splash system. In order to bring these engines up to latest design embodied in our newest models, we have eliminated the oil pump and trough and added a dipper on the connecting rod. To convert these engines to simple splash system see following instructions:

MODEL S—Use Oil Replacement Kit No. 290923.

MODELS L-T—Use Oil Pan Replacement Kit No. 290924.

Proceed as follows to assemble:

Disassemble cylinder head and remove piston and connecting rod assembly from engine. Discard old connecting rod, replace with new rod No. 65756 and reassemble rod and piston to engine. Fig. 188. Discard old oil pan, trough assembly and all pump parts. Replace with new oil pan which is minus oil pump, and assemble to engine. Reassemble cylinder head.

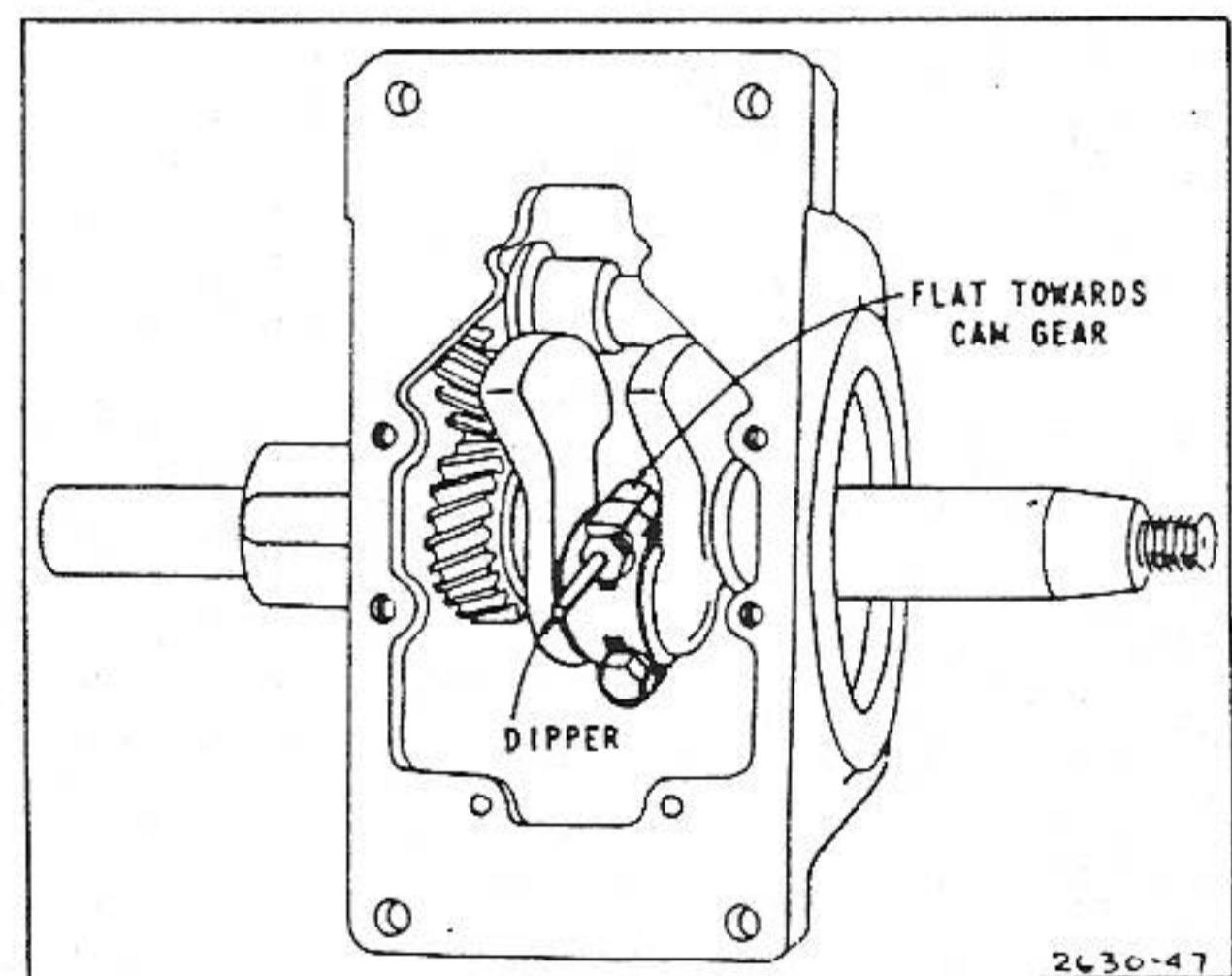


FIG. 188—POSITION OF OIL DIPPER

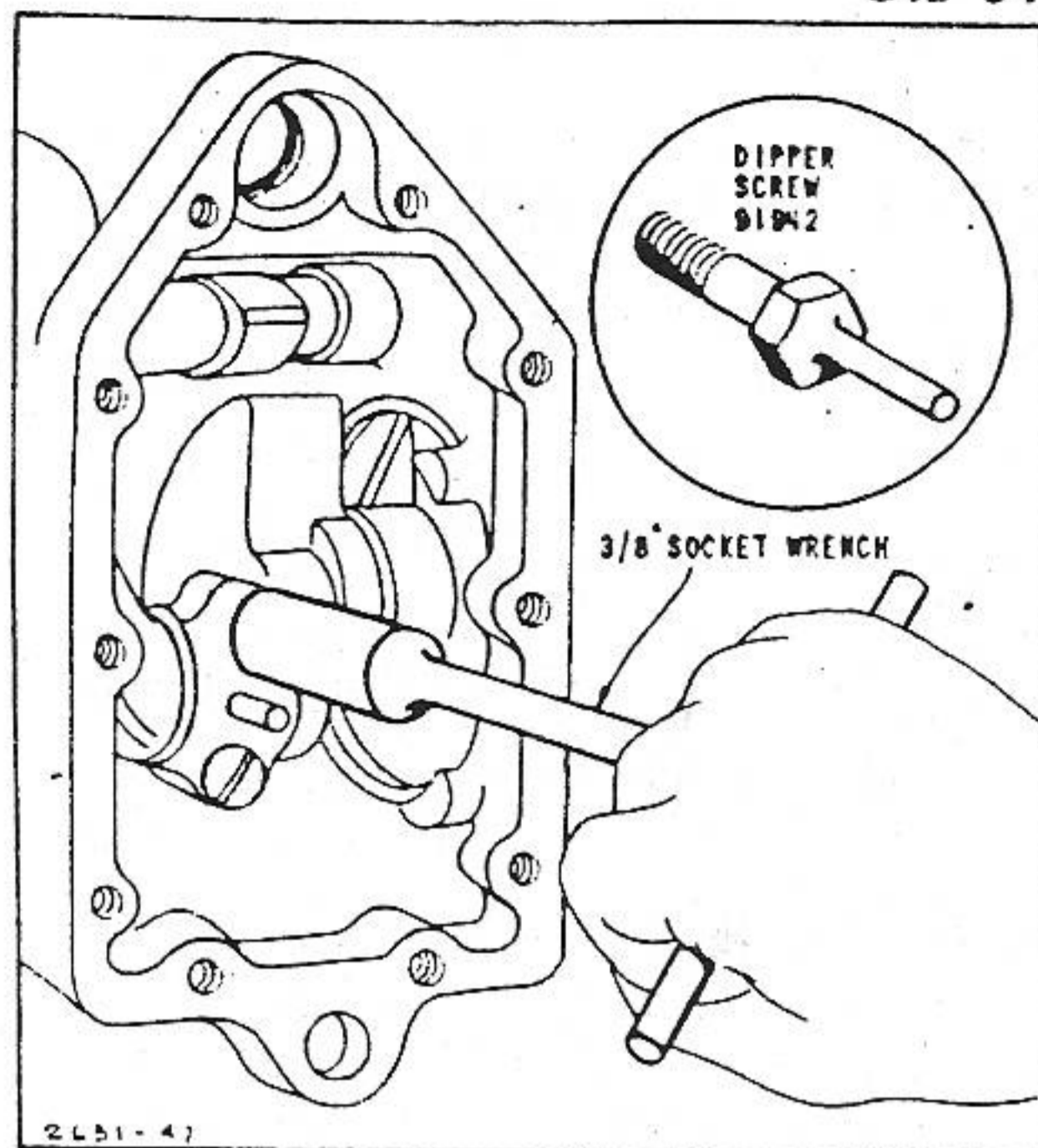


FIG. 189—INSTALLING DIPPER SCREW

**ARTICLE 10—Models WM-PCWM-WMG**

MODELS WM-PCWM—Use No. 91942 Dipper Screw and No. 62904 Base Plate.

MODELS WMG—Use No. 91942 Dipper Screw and No. 62947 Base Plate.

**To Assemble**

Remove the fillister head screw nearest the carburetor side of the engine from the connecting rod. In its place install Dipper Screw No. 91942. Fig. 189. Tighten screw and bend locking plate against hexagonal head.

Discard old plate, oil trough and pump parts and assemble new base without oil parts.

On Model WMG see Chapter 11 for instructions on aligning generator before tightening base bolts.

NOTE: If connecting rod in engine is to be discarded for any reason, replace it with connecting rod No. 29733. Use the proper base plate as listed above but dipper screw No. 91942 will not be needed as this rod assembly includes a dipper.

## STARTERS

**To Adjust and Assemble Starters****Models A-B-L-M-S-T**

ON ALL LEVER MODELS the starter return spring must always have sufficient tension to return lever against its stop. To increase tension of spring, move small hook at end of spring back to next peg. Fig. 190.

ON HAND CRANK MODELS tighten pinion gear on crankshaft securely. Oil crankgear shaft through the oil cup, and grease the pinion and crank gear teeth to reduce wear.

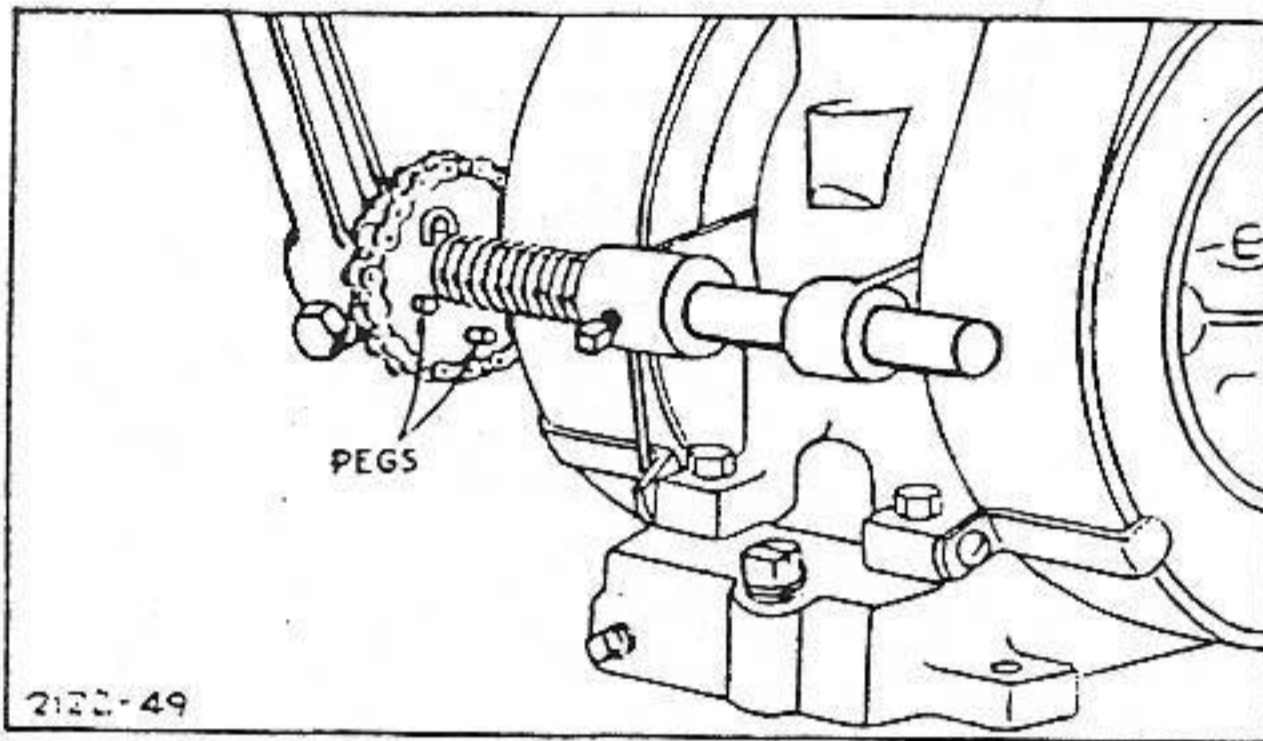


FIG. 190—ADJUSTING SPRING TENSION

**Models FH-FI**

On the early Model FH engines (before Serial No. 57100), a clock spring type return spring was used. Correct assembly of spring to case is shown in left view in Fig. 191. To increase tension on the spring, loosen set screw on starter shaft and turn shaft to the left with a screw driver at the slot, then lock shaft in place. The later type spring used on Model FH (after Serial No. 57100) is shown in the right view of Fig. 191. One end is hooked through hole in sprocket and the other end in the spring lock. To change tension on this spring, loosen set screw and move starter assembly out far enough to permit turning of spring lock, then turn lock forward to increase tension and backwards to decrease tension. Slide starter assembly in place with spring lock up against blower case and lock shaft in place. Chain must align properly with sprocket on later models and with sprocket and sheave on earlier models. If out of alignment use pipe wrench to straighten lever.

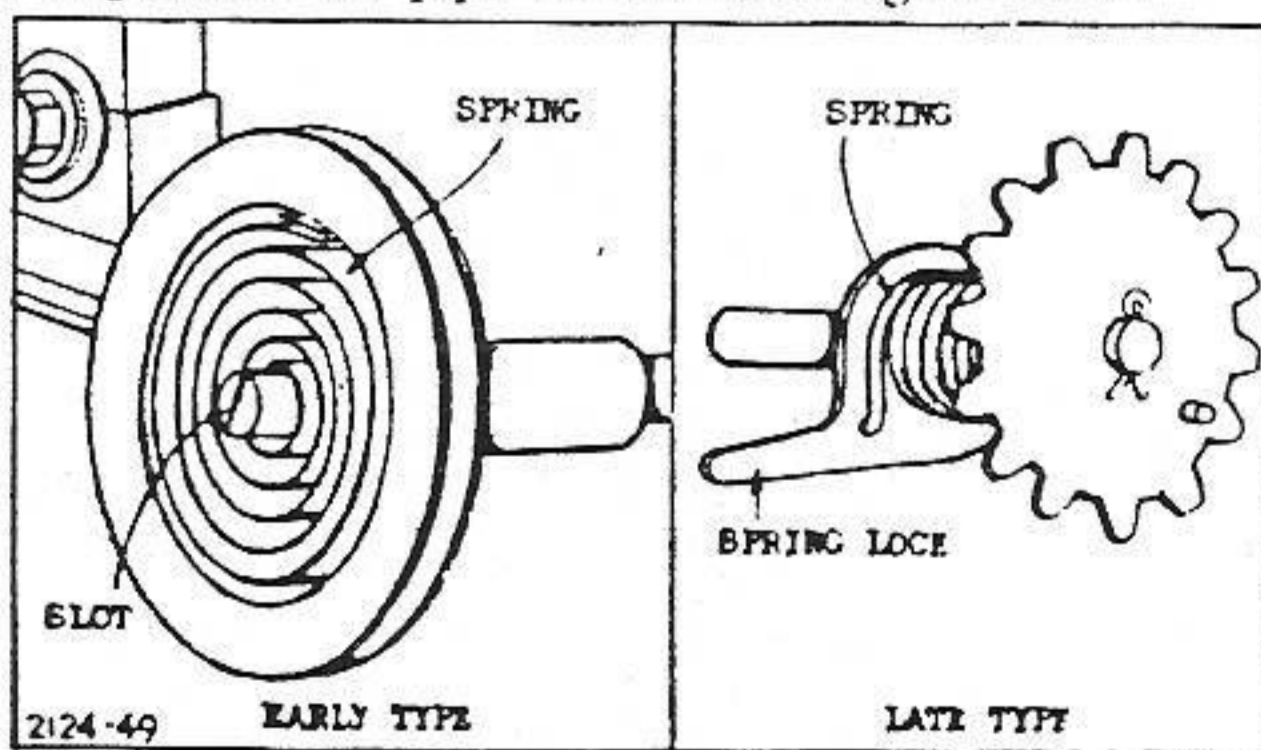


FIG. 191—ADJUSTING SPRING TENSION

**Models H-Y**

The gear sector on the starter pedal of this type of engine should align squarely with the pinion on the crankshaft. Use washers on pedal shaft to adjust gear sector in the middle of the pinion gear. Be sure the sector does not bind at any place. To replace this sector, it is necessary to remove only two rivets and rivet a new one into place.

The starter clutch pinion (No. 63316) on the first Model H and Y engines had blunt gear teeth. This starter pinion was used with sector assemblies Nos. 29180 and 29185, which are equipped with a spring tooth assembly as shown in Fig. 192. Do not use this pinion with sector assemblies Nos. 29539 and 29540. The new starter clutch pinion (No. 63621) has pointed gear teeth. This pinion can be used with all of the sector assemblies shown in Fig. 192.

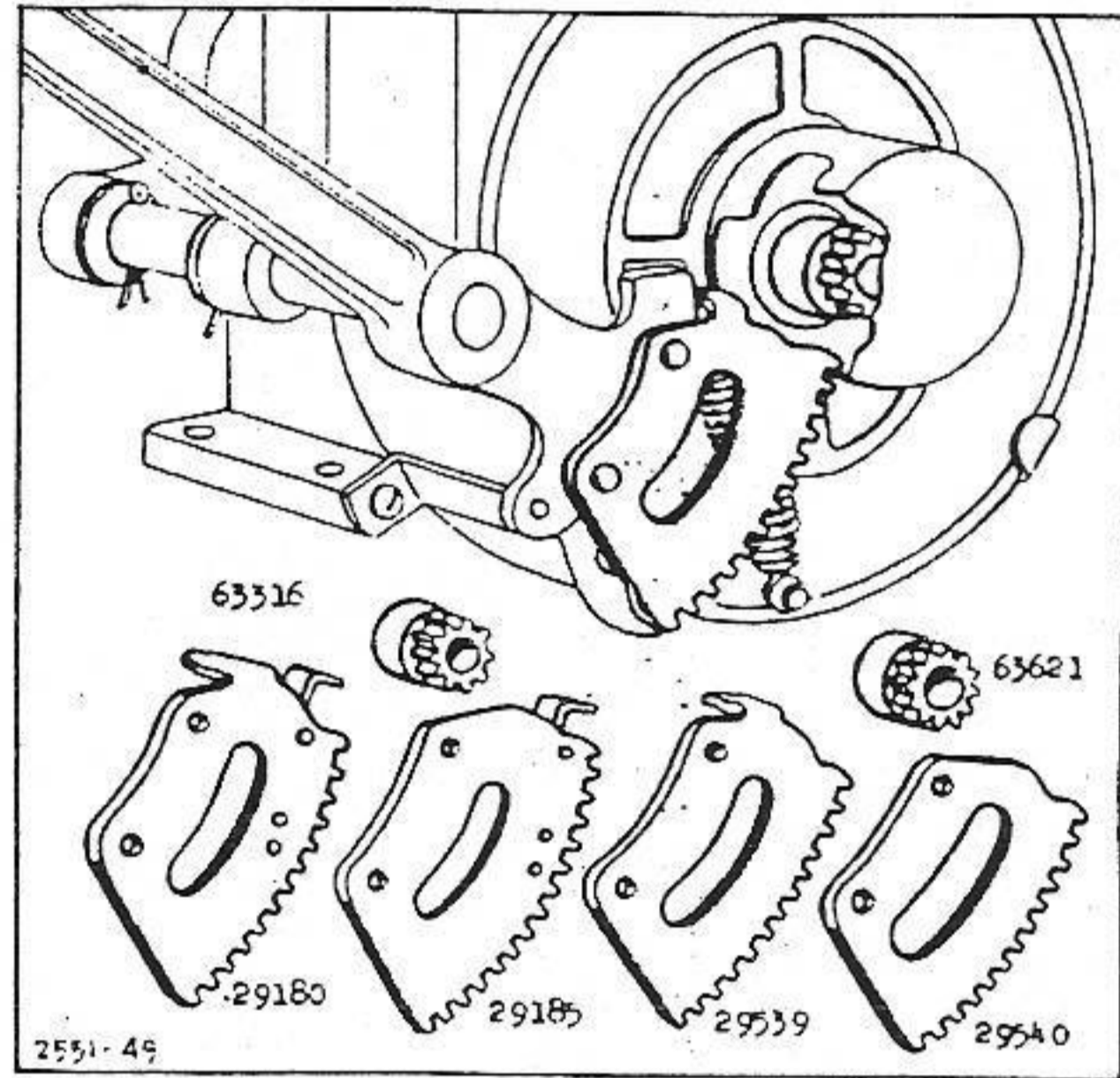


FIG. 192—STARTER SECTORS

**Models K-Z-ZZ**

To assemble starter, place two eccentric bushings on upper studs, and two plain washers on lower studs. Then place starter bracket gear and shaft assembly and four plain washers, and nuts on studs. Press starter gear toward engine until teeth mesh with pinion. Hold it in this position. Turn two eccentric bushings (Fig. 193) until starter gear can be moved back and forth approximately  $1/32$ " without moving pinion or crankshaft. Tighten nuts securely. Oil the crankgear shaft through the oil cup and grease the pinion gear teeth occasionally to reduce wear.

**Models Q-R-W**

The early Model Q engines were equipped with a starter as shown in right hand view of Fig. 194. If gears of this type starter bind, place shims under starter bracket.

The later Model Q and all Model R and W hand crank engines were equipped with a starter as shown in left hand view Fig. 194. If gears of this type starter bind, place shims between starter bracket and crankcase.

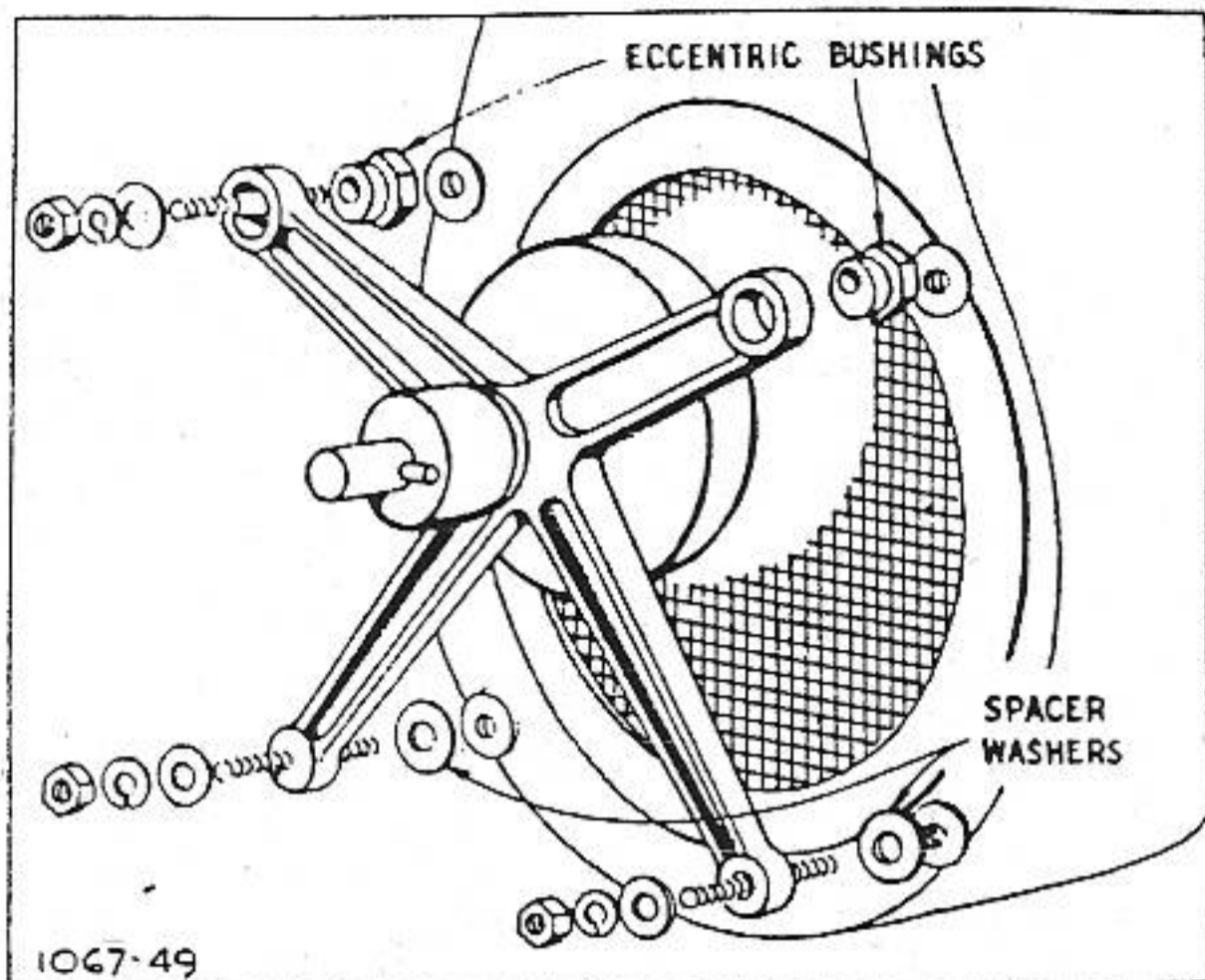


FIG. 193—STARTER ASSEMBLY

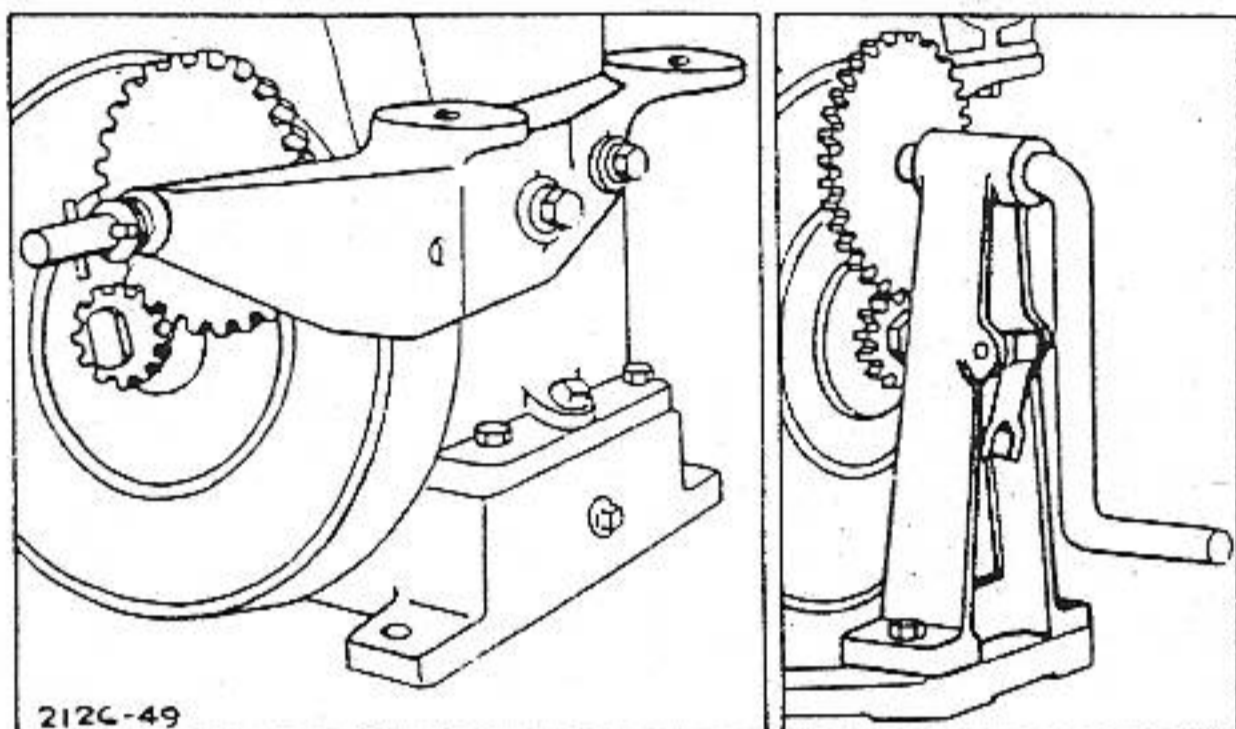


FIG. 194—STARTER ASSEMBLY

**Models WI-WM-WMB-WMI**

The starter pedal is made in two parts—(1) pedal proper and (2) pedal stop. These are held together with an adjusting bolt. To adjust, loosen the bolt and set pedal to desired position. Adjust the pedal to get the longest possible stroke without striking any part of the machine. The first tooth on the starter sector must clear the teeth of the starter pinion.

Should the starter pedal return spring loosen or lose its tension, loosen the bolt which holds the return spring cup. Turn the cup to the left until there is enough tension to return the starter pedal back to normal position after depressing it, then tighten the bolt. Too much tension may cause spring to break. Be sure the spring is in the proper position with the long end below the pedal adjusting bolt and the hooked end in the slot of the cup. Fig. 195.

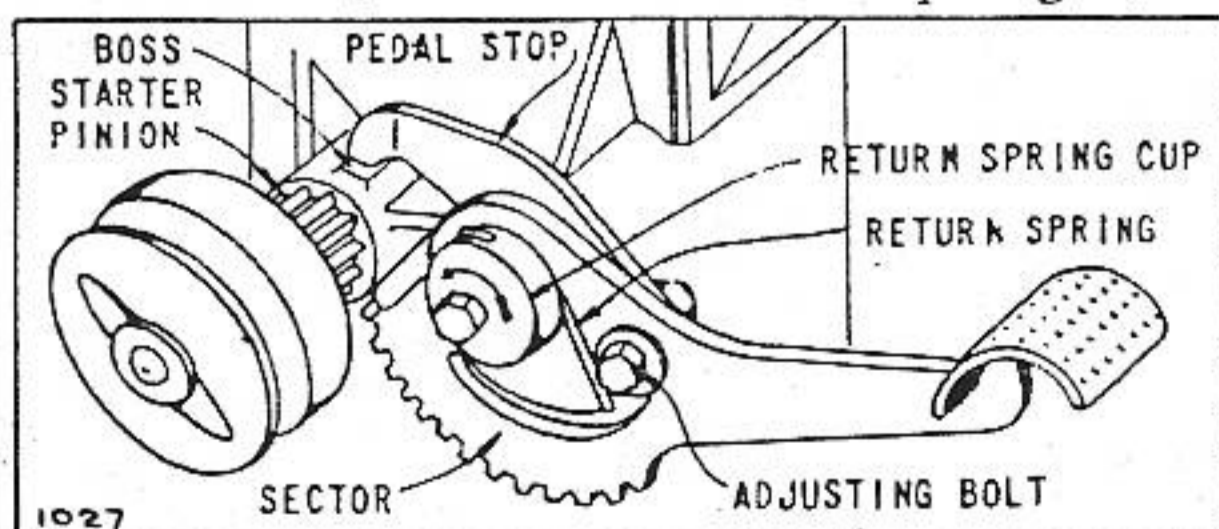


FIG. 195—STARTER ASSEMBLY

If starter pedal return spring and cup have been removed and washed, grease before reassembling.

**To Repair Starters**

**Models A-L-M-S-T**

Broken chains can easily be repaired with standard repair link assembly No. 69928. Fig. 196.

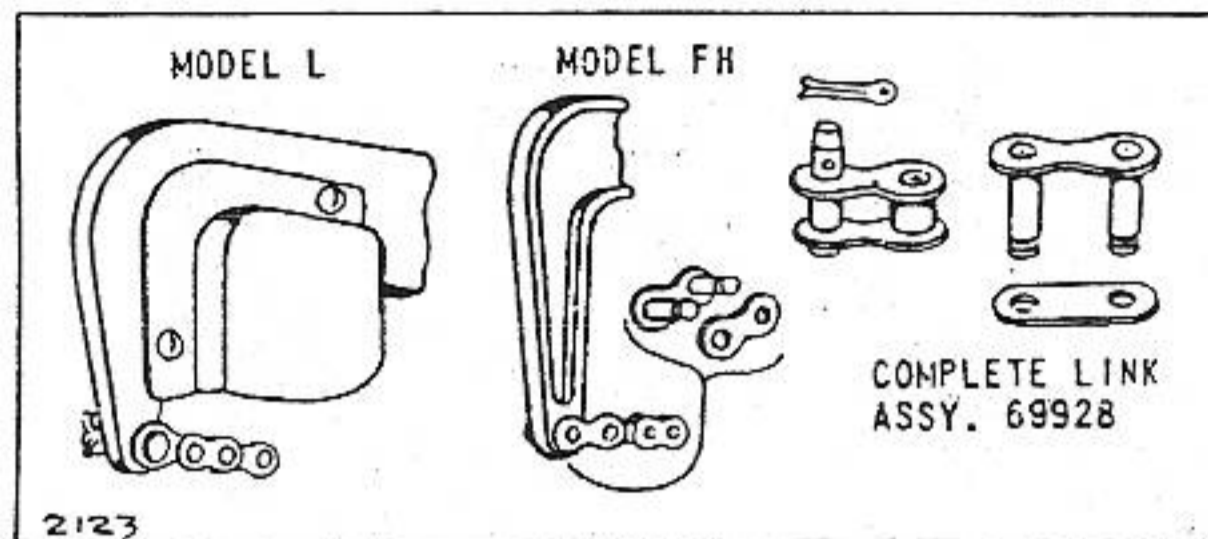


FIG. 196—STARTER REPAIR LINK

**Models H-Y**

If starter sector slips over pinion teeth or sector and pinion teeth have too much clearance, it is usually caused by a worn starter shaft hole.

To repair, use reaming fixture No. 60079-T3. Remove starter pedal, blower case and clutch. Slip frame (A) over end of crankshaft and into left starter lug hole. Fig. 197. Ream with the smaller (13/16") dia. shell reamer. Use nut (B) on end of arbor to draw reamer in uniformly. If nut (B) turns, lock it with a suitable pin at slot. Run reamer in far enough to chamfer end of hole to take bushing easier.

NOTE: If 13/16" diameter of reamer does not clean up worn hole, run the 7/8" diameter through. In most cases the smaller diameter is sufficient. After reaming, press in the right size bushing. The 13/16" diameter bushing is Part No. 63673. The 7/8" diameter bushing is Part No. 63706. With bushing in place, burnish hole by pushing steel ball (C) through twice with plunger (D). Try starter shaft in hole. If shaft is tight in hole, push steel ball through third time. Shaft should have good slide fit in hole.

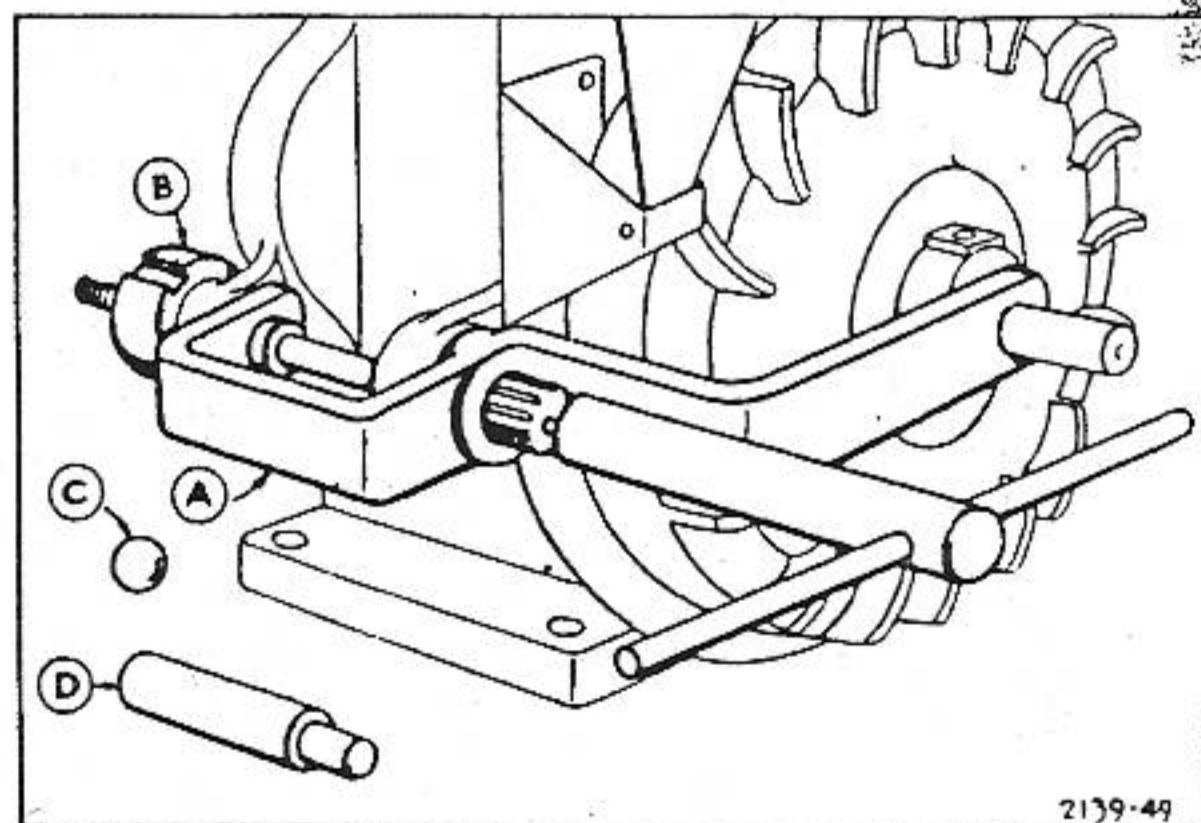


FIG. 197—REPAIRING WORN STARTER SHAFT HOLE

## STARTERS (Cont'd.)

### To Replace Spring and Rope on Retrievable Starter

1. Remove blower housing with starter case attached.
2. Take off 5 nuts, screws and washers holding case to blower housing.  
NOTE: If replacing rope only, omit instructions in steps 4 to 12 inclusive and follow instructions in steps 13 to 18.
3. Unwind rope. Wedge screw between pulley and case to prevent spring unwinding. Ill. 5. Untie knot and remove rope.
4. Bend up two tangs holding pulley to case.
5. Lift out pulley. NOTE: If starter assembly includes 2 segment shaped drag plates, discard these. Remove spacer and broken spring.
6. Fasten starter case with two fairly large nails to a solid surface.
7. Hook new spring around nail as shown in Ill. 1. Smear some grease in a cloth and run cloth along the length of spring.
8. Hook end of spring with straight hook in slot of pulley. Be sure spring end is tight against slot end. (Ill. 2, Fig. A.)
9. Insert spacer collar as shown to hold spring in place. (Slot in collar opposite spring end.) (Ill. 2, Fig. B.)
10. Place pulley and spring in case with edge of spring in slot. (Ill. 3.)
11. Bend down 2 tangs opposite one another to within  $\frac{1}{8}$ " of pulley surface. Do not use 4 tangs. (Ill. 4.)
12. Use a  $\frac{3}{4}$ " square stick about 6" long. Mark pulley and wind up  $13\frac{1}{4}$  turns counter clockwise with a wrench. Push end of spring until it snaps into hole of case. Hold the pulley in this wound up position and wedge a  $\frac{3}{16}$ " screw or other suitable object between pulley and case. (Ill. 5.)  
USE ROPE No. 66334 WITH SHEAVE HAVING  $\frac{3}{16}$ " WIDE GROOVE. ROPE No. 66429 IS USED WITH SHEAVES HAVING  $\frac{7}{32}$ " WIDE GROOVE.
13. When replacing rope in handle tie a figure eight knot around pin with about a  $\frac{3}{4}$ " end exposed. Pull pin into slot of handle. (Ill. 6.) Wind a thin piece of wire around other end of rope, pass through eyelet of case and between flanges of pulley. Select the nearest hole that comes within arc indicated by arrows in Ill. 7, Fig. A. Slip the wire and rope through this hole. It is permissible to back pulley off not more than  $\frac{1}{4}$  turn to bring hole in most favorable position.
14. Remove wire and tie a single knot at end of rope. (Ill. 7, Fig. B.) Pull rope tight. Use a block of wood and compress knot until it extends not more than  $13\frac{1}{32}$ " above face of pulley. (Ill. 8.)
15. While holding rope tight remove wedge and release pulley slowly.
16. If square shaft of clutch has one side marked "top," this must be on top and as nearly level as possible when starter and blower housing are reassembled to engine.
17. Fasten starter to blower housing with screws, nuts and washers.
18. Mount blower housing and starter to engine.
19. Pulley clearance around case should be equal. Spring will not wind up rope if pulley is not central. Bend legs of case to centralize pulley in case.

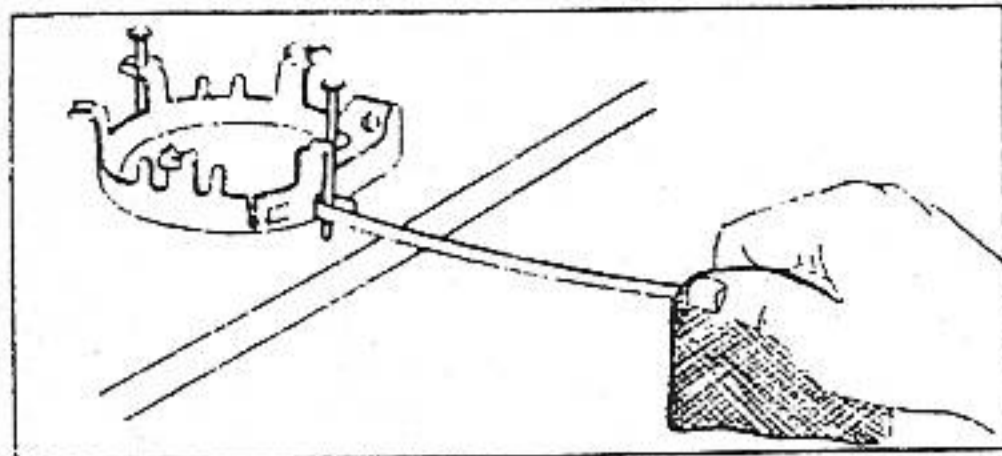


ILLUSTRATION NO. 1

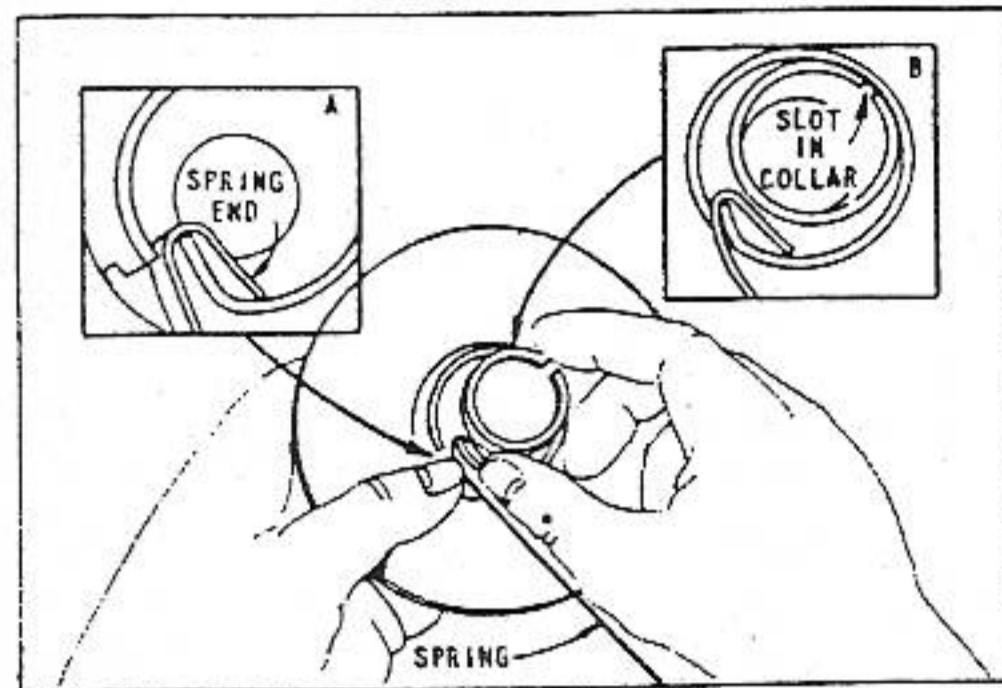


ILLUSTRATION NO. 2

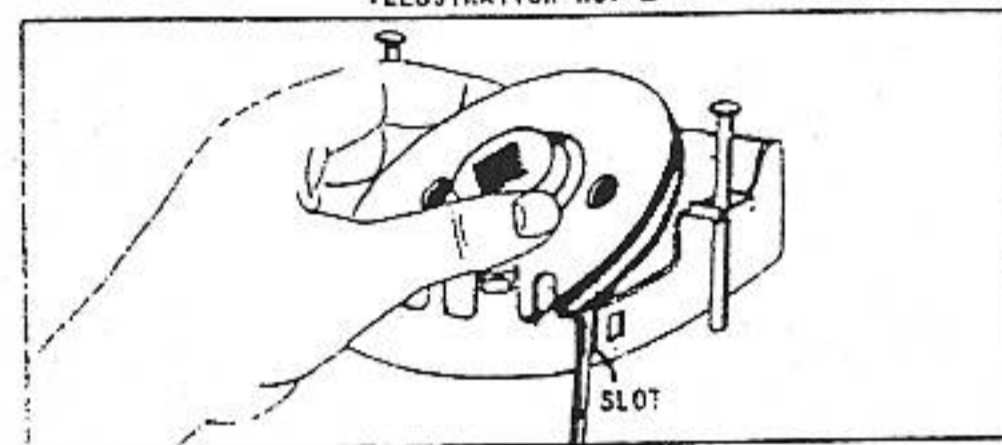


ILLUSTRATION NO. 3

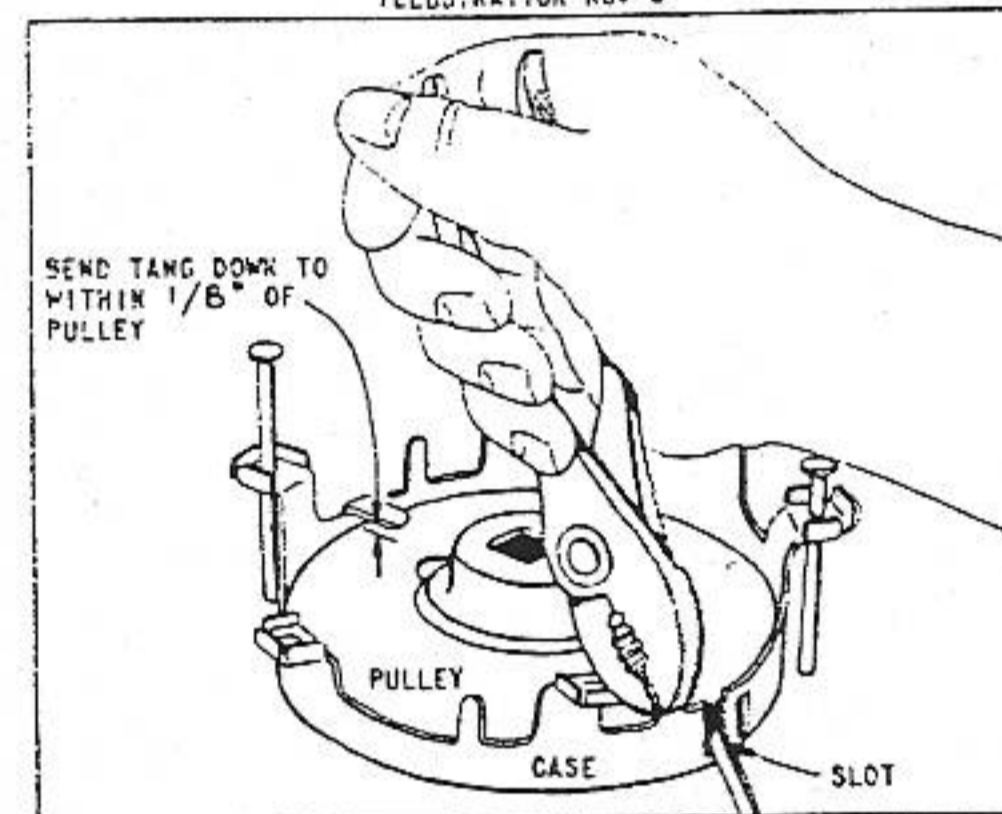


ILLUSTRATION NO. 4

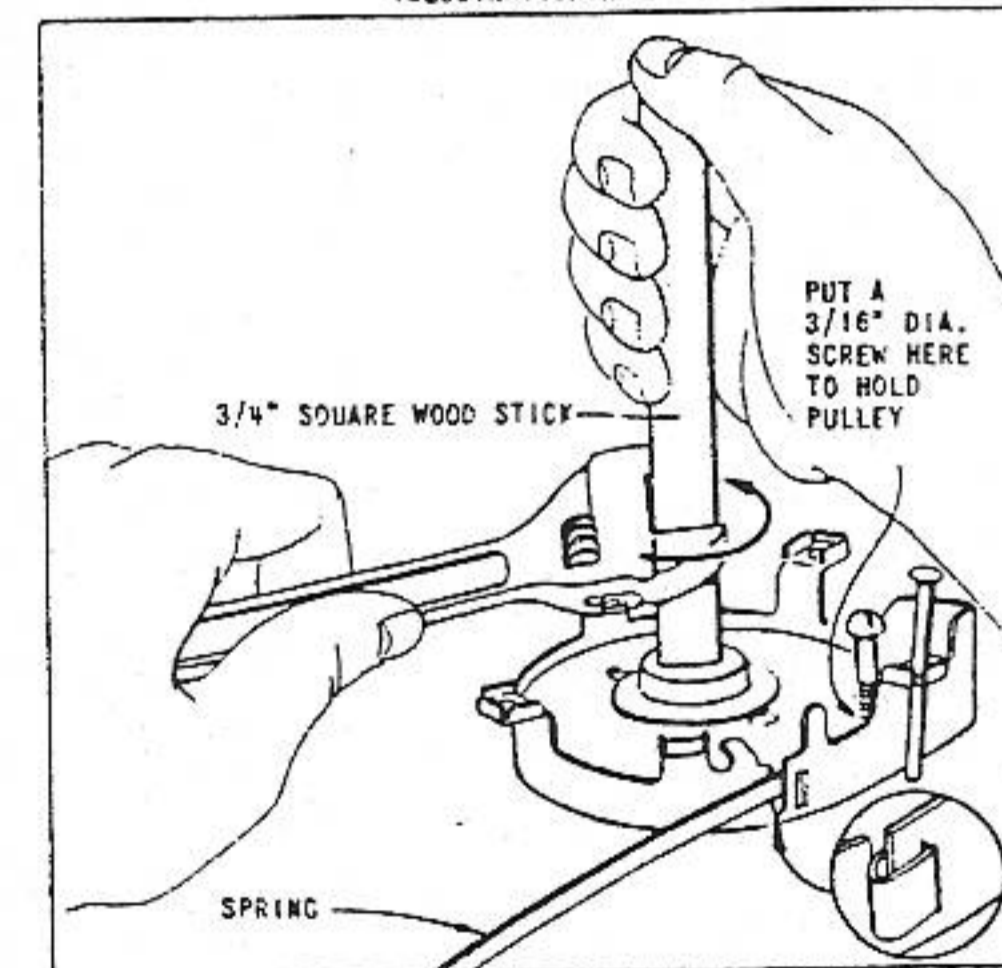


ILLUSTRATION NO. 5

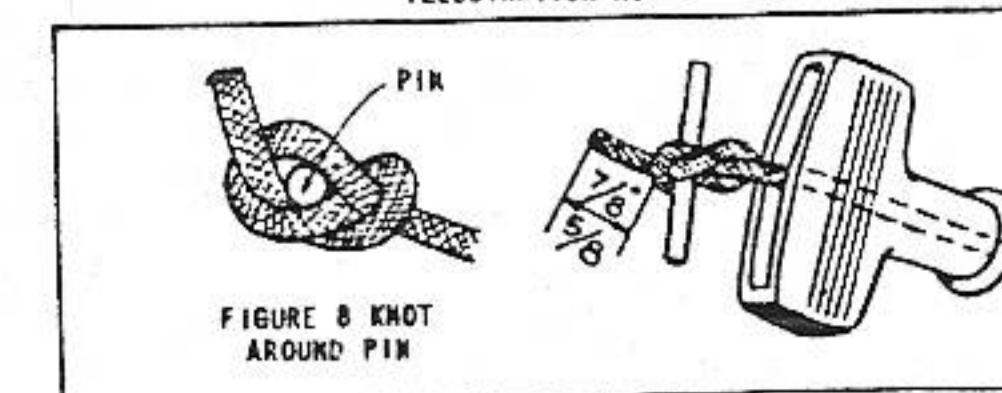


ILLUSTRATION NO. 6

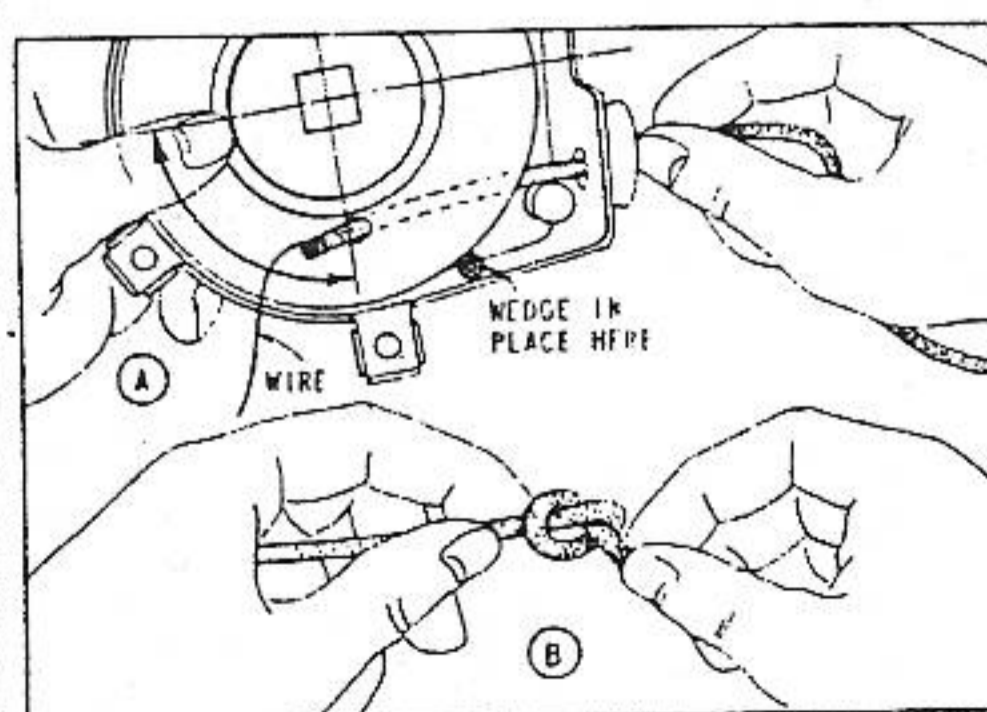


ILLUSTRATION NO. 7

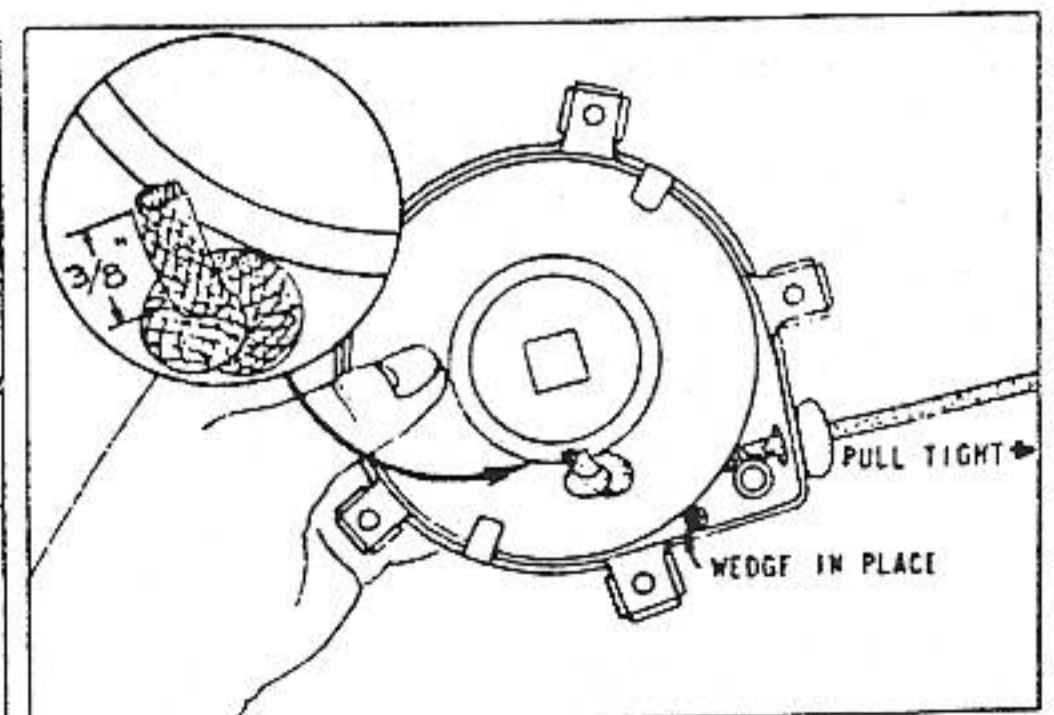


ILLUSTRATION NO. 8

## SPECIAL INFORMATION

This chapter consists of special information on miscellaneous topics which are not otherwise covered. These scattered subjects are, of course, hard to catalog and so are not in particular arrangement. As changes occur and new information is needed it will be forwarded to you to be added herein.

### PUMPING OIL

#### Models FI-FJ

If you receive engines of either of these two models which are pumping oil, the trouble can usually be corrected by installing an L type breather, Part No. 69259, and extension piece, Part No. 61385, in place of the standard breather. When making this change, be sure to shellac all joints.

#### Other Models

Oil pumping can be caused by the center compression ring being installed upside down if it is the scraper type. Be sure the scraper or recessed edge is installed down toward the oil ring.

### POWER LOST WHEN HOT

#### Model FI

Some of these models were equipped with a large spark plug hole in the cylinder head. The plug becomes overheated and causes pre-ignition. To correct, remove spark plug. Install plug nipple, Part No. 67773, with gasket No. 27090 and then install spark plug in nipple.

#### All Models

Be sure all cooling fins and spaces are clean so air can reach all parts for cooling.

### ASSEMBLING CAP SCREWS TO ALUMINUM PARTS

#### All Models

Always apply graphite grease to cap screws when assembling them to aluminum parts.

### WARPED MAGNETO PLATE

#### All Models

Magneto plates sometimes warp. When this occurs it permits oil leaks between the magneto plate and crankcase. To correct this, mount magneto plate in a lathe and turn down mounting surface until it is level. After this operation always check crankshaft end play and make necessary adjustments as outlined in Chapter 6.

### WORN THRUST FACE ON CRANKCASE COVER

#### Models B-K

If the thrust face on the crankcase cover becomes worn it may be repaired by using bronze thrust washer, Part No. 62883. Fig. 199. Proceed as follows:

Place crankcase cover in a lathe and cut down thrust face until distance between thrust face and mounting is  $\frac{3}{8}$ ". Fig. 199, Ill. 1. Drill two No. 31 holes in the thrust face

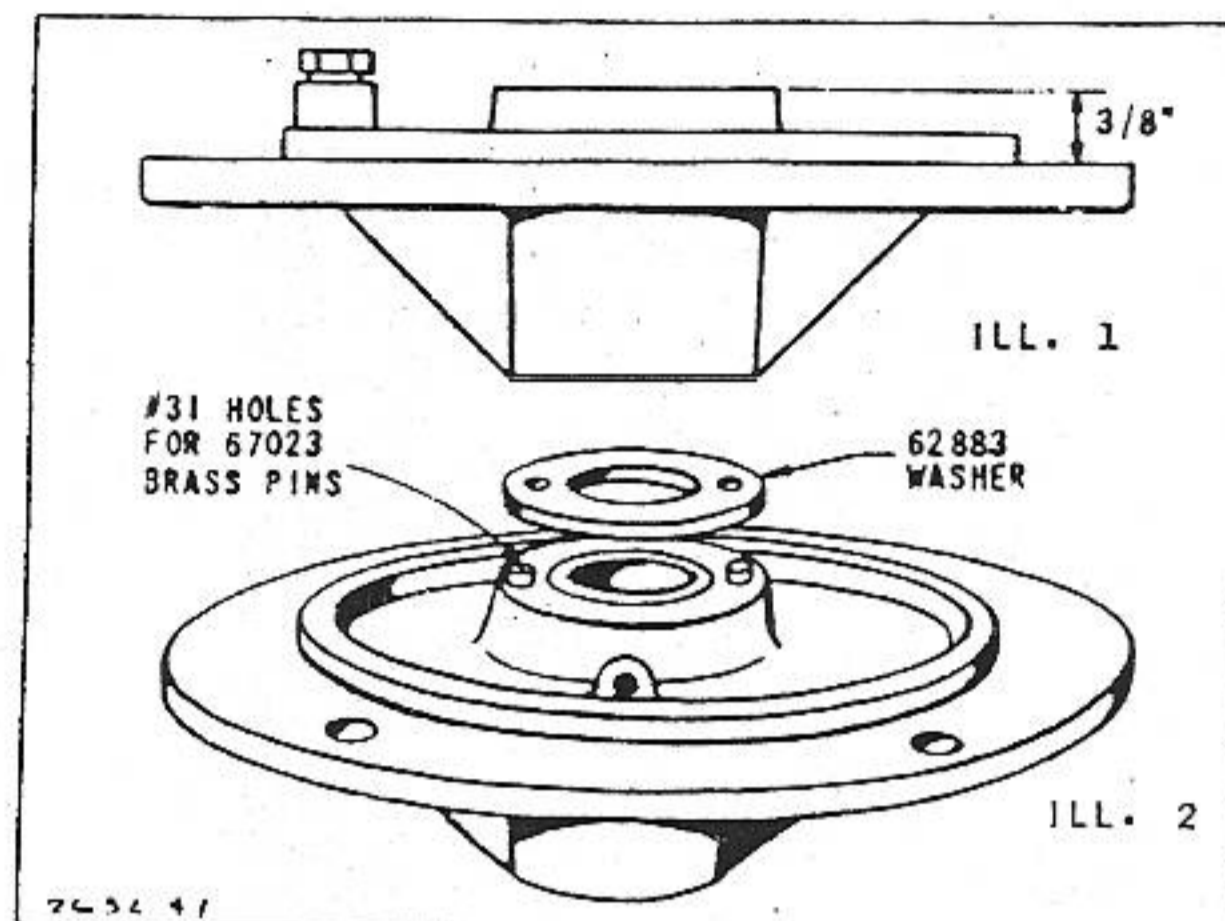


FIG. 199—REPAIRING WORN THRUST FACE

using thrust washer No. 62883 as a jig. Holes should be on a horizontal line with the center of bearing. Be sure washer is centered. Fig. 199, Ill. 2.

Press into each drilled hole a brass pin, Part No. 67023, so that they are flush, or  $\frac{1}{64}$ " less than flush, with the face of the washer. Assemble washer so that oil groove is toward crankshaft. Check and correct end play.

### OIL LEAKS AT EXHAUST VALVE PUSH ROD HOLE

#### Models F-FB-FC-FE-FG-FH

Oil leaks at the exhaust valve push rod hole on these models may be caused by the factors listed below together with the remedy for correcting the trouble:

1. Dirt or paint of the push rod or in the push rod hole of the crankcase. To correct, remove push rod. Clean rod and hole thoroughly. Be sure to remove all paint from the rod where it enters the hole.
2. Push rod is bent and not free to turn in the push rod hole of crankcase. If this is evident, straighten push rod and be sure it turns freely when the exhaust valve is closed.
3. The push rod and hole are worn. Fig. 200.

Drill push rod hole  $\frac{7}{16}$ " deep in crankcase with a  $\frac{23}{64}$ " dia. x  $8\frac{1}{2}$ " long drill. Then ream hole with  $\frac{3}{8}$ " dia. reamer. Press in bushing No. 63431 and ream hole in bushing with a No. 10 drill or  $.193$ " dia. extension drill. The extension on the No. 10 drill must be long enough so that the drill chuck will clear the cylinder fins. Install new push rod, Part No. 23566.

NOTE: When inspecting any of these engines that cannot be run when received, check the push rod hole with a No. 9 drill. If the No. 9 drill enters the push rod hole, a No. 63431 bushing must be installed.

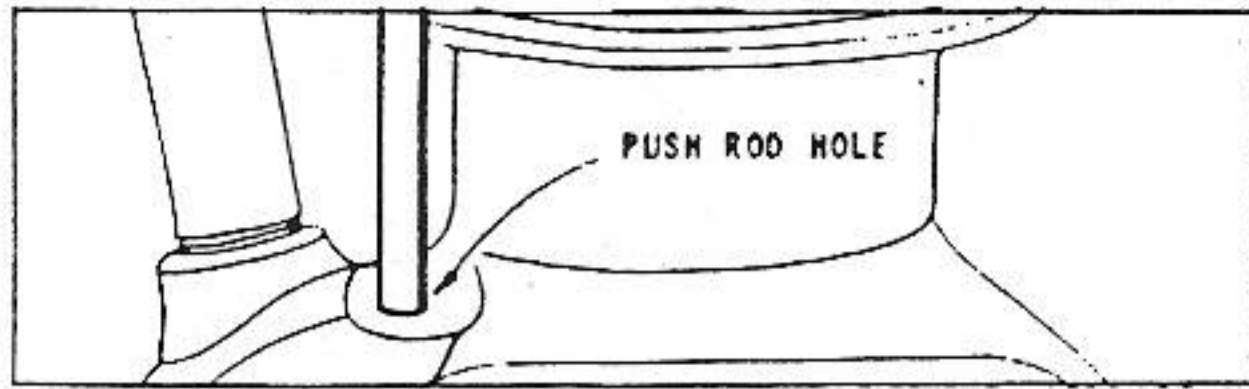


FIG. 200—PUSH ROD HOLE

### TO REMOVE RUSTED FLYWHEEL

#### Model A-B

Remove blower housing, rope starter pulley, crank starter pinion, or flywheel nut. Assemble flywheel puller No. 29157 to flywheel and tighten cap screws. Apply pressure at the outer rim of flywheel with one hand to take up crankshaft end play. While applying this pressure, strike flywheel puller several sharp blows with a one pound hammer until flywheel comes off.

In rare cases, the flywheel hub is rusted to the crankshaft and above procedure will not remove it. In such cases proceed as follows:

Place engine on drill press table and block it so that flywheel is uppermost and in a horizontal plane. Fig. 201. Drill a series of  $\frac{1}{4}$ " holes that overlap around the steel hub on the line at which steel hub and die cast metal meet. Drill holes at a point between base and crankshaft until hub separates from outer portion of flywheel. Rotate flywheel for each successive hole. This will avoid damaging coil and contact points.

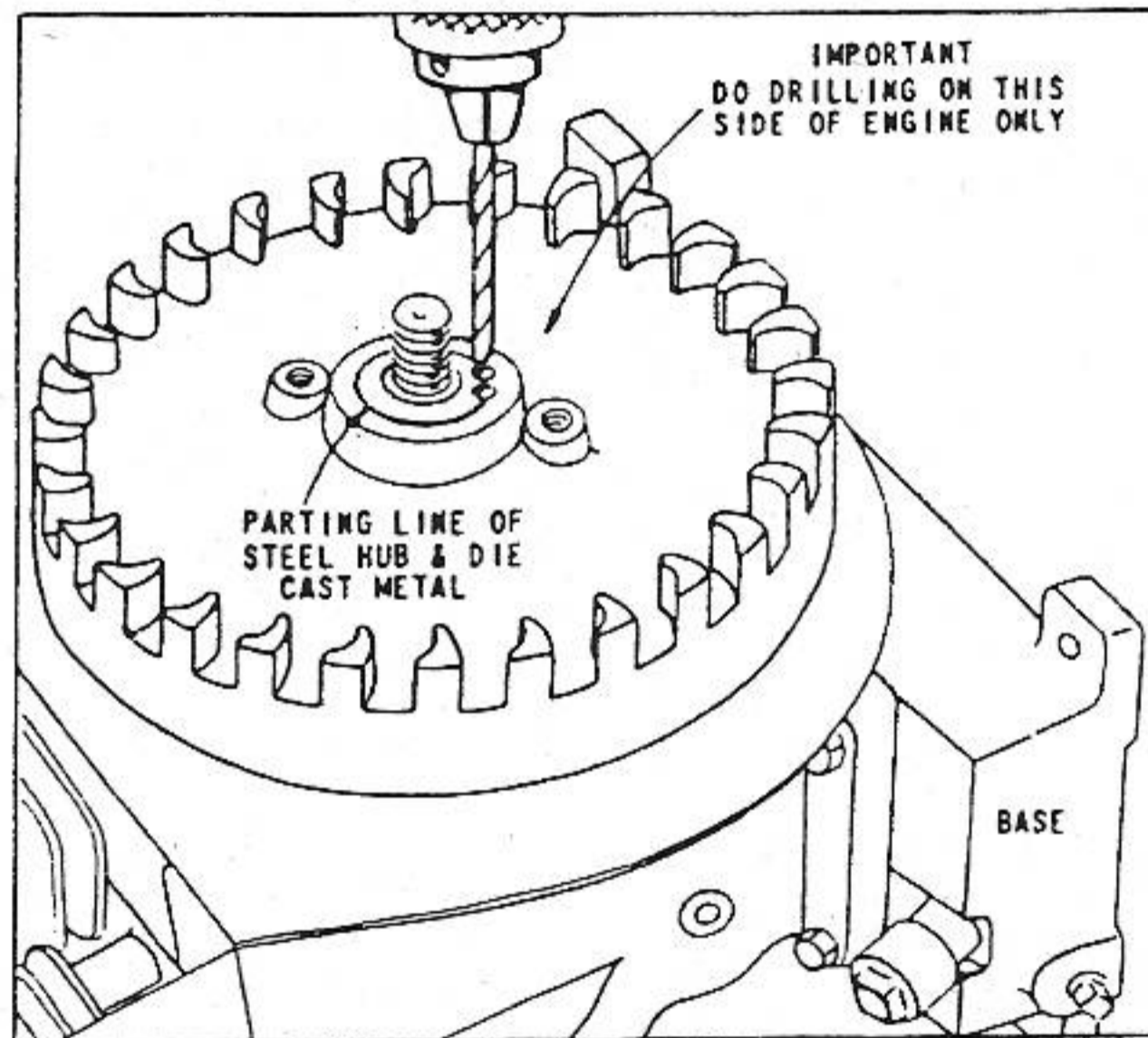


FIG. 201—REMOVING RUSTED FLYWHEEL

Set the engine on a bench and turn crankshaft until keyway in hub is in the uppermost position. Place a block under hub and split hub at the keyway with a sharp cold chisel. Fig. 202.

### GEAR REDUCTION ASSEMBLIES

#### To Ream Reduction Gear Cover Bushing

##### Models IR-NR

(We recommend the use of expansion reamer Type A.L.P. .730" to .780" manufactured by Lempco Products Co., Bedford, Ohio. This reamer includes tapered guide bushing.)

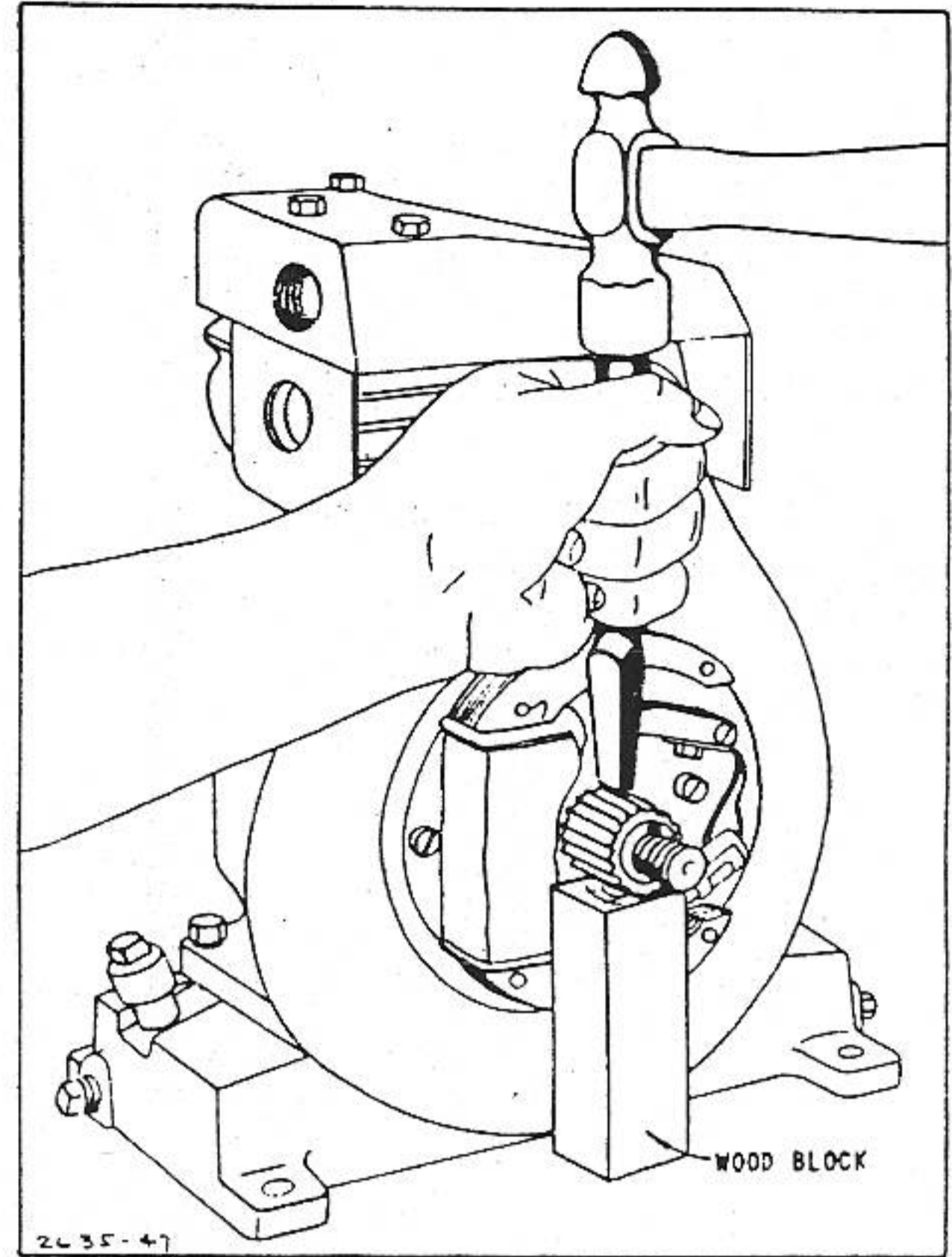


FIG. 202—REMOVING FLYWHEEL HUB

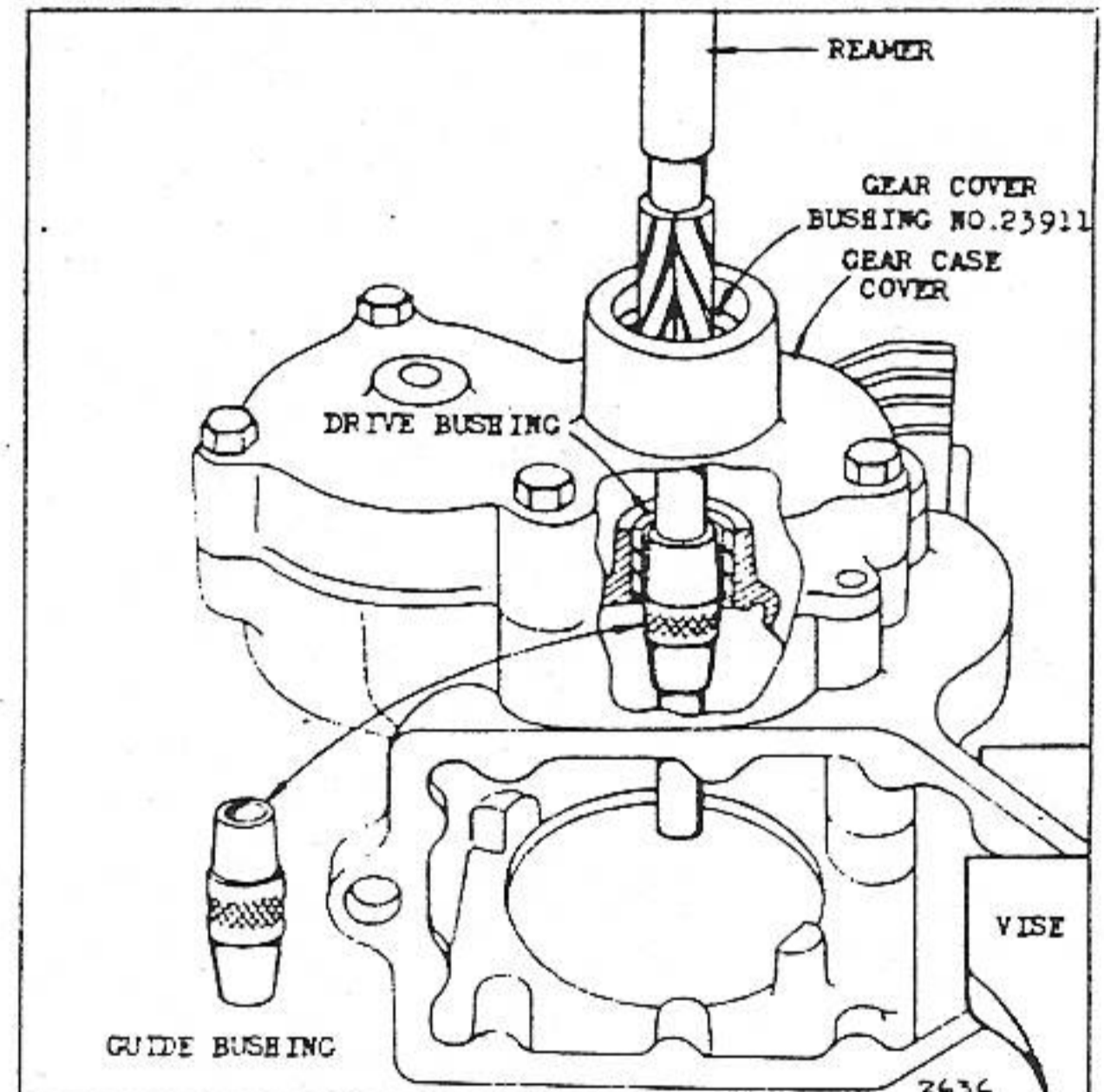
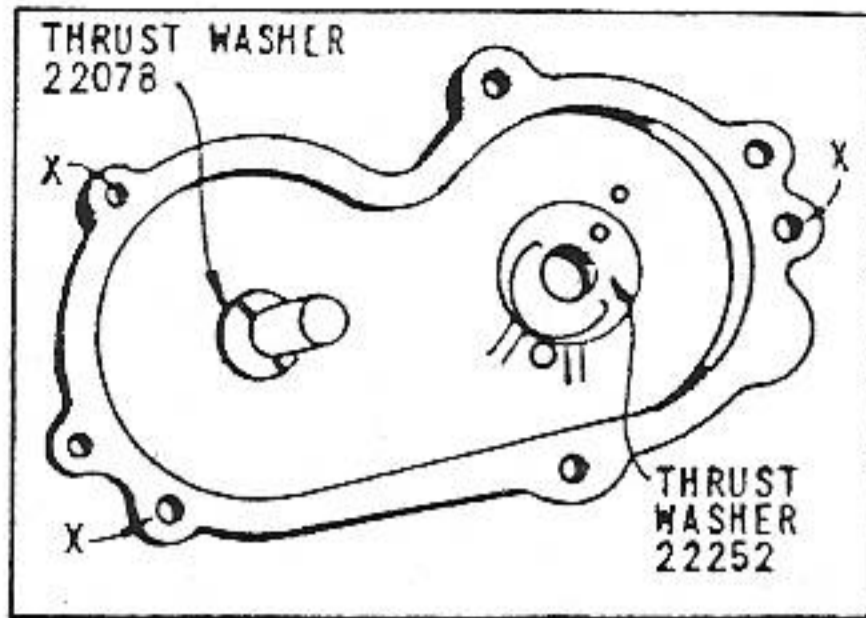
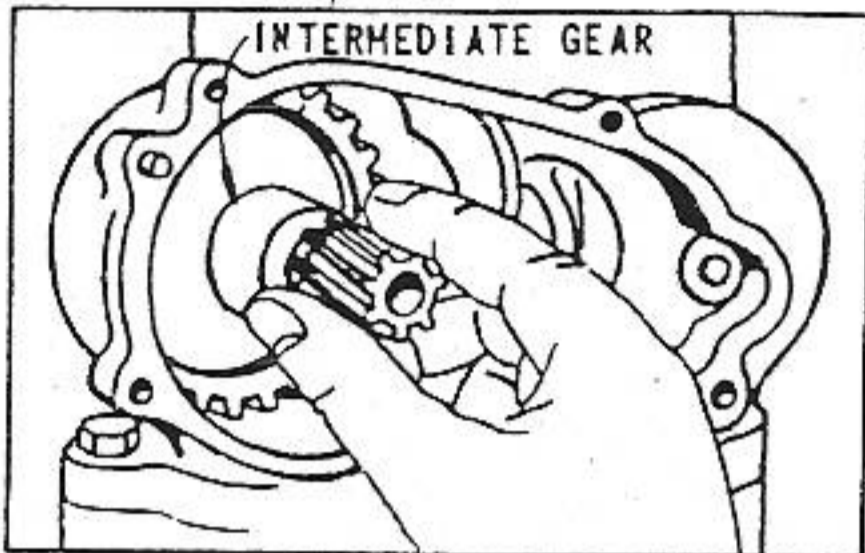


FIG. 203—INSERTING GUIDE BUSHING

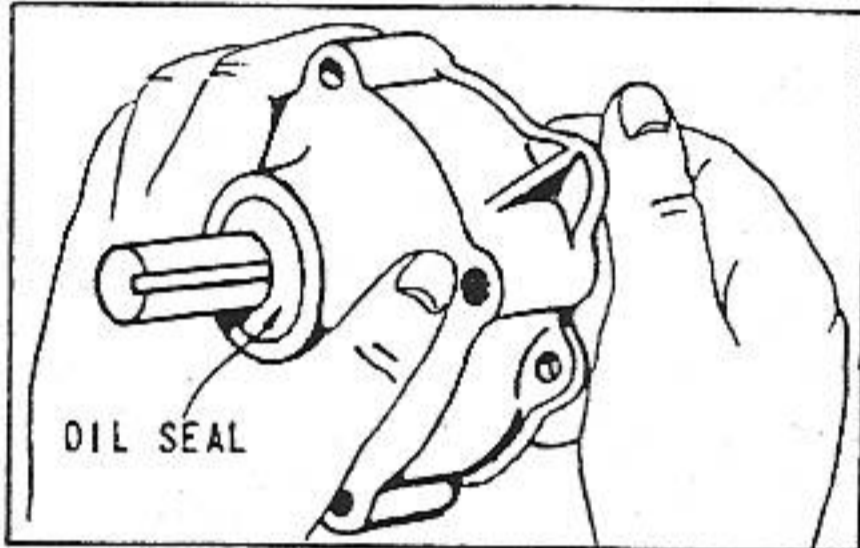
1. Remove old bushing from gear cover.
2. Press in new bushing, Part No. 23911. Be sure oil hole in cover and bushing are aligned. Bushing is slightly shorter than the thickness of cover and equal space should be allowed at each end.
3. Assemble cover to cylinder without gears and clamp cylinder in vise with cover up.
4. Insert guide bushing into drive bushing from inside the cylinder. Use end of guide bushing that fits best.
5. Insert reamer as shown in Fig. 203. Ream to .750"-.7515". Continue to turn reamer to right while removing it from bushing.



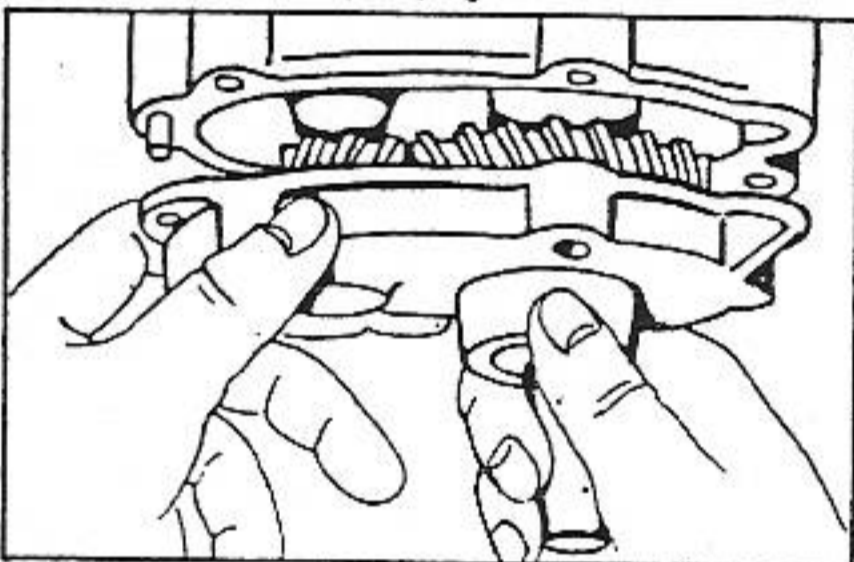
ILL. 1



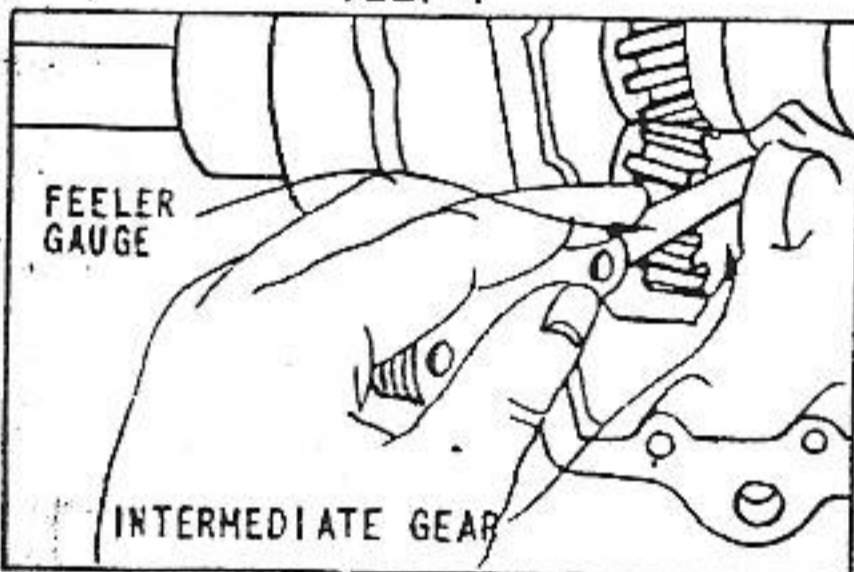
ILL. 2



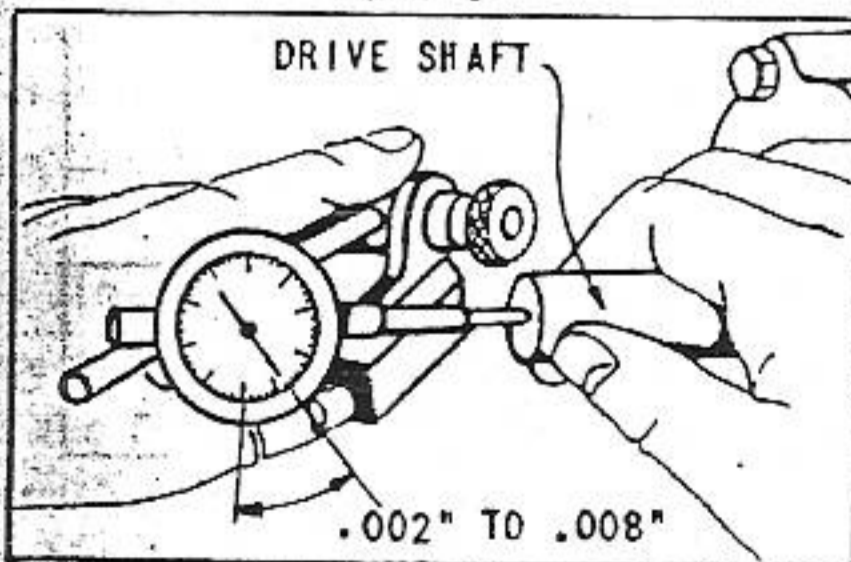
ILL. 3



ILL. 4



ILL. 5



ILL. 6

FIG. 204—REDUCTION GEARS

### To Assemble Gear Case Cover Models IR-WR-NR-UR

#### Models IR-WR

1. Place thrust washer 22078 in gear case cover, oil groove up, on thrust face at intermediate gear shaft. Locate it with dowel pin. Use a little grease to hold it in place. Fig. 204, Ill. 1.
2. If intermediate gear has too much end play and drive shaft end play is correct, remove gear case cover and place steel shim Part No. 22872 under thrust washer No. 22078. Use a little grease to hold them in place. Ill. 1.

#### Models NR-UR

1. Proceed as above but place thrust washer 22252 at drive shaft hole. Ill. 1.
2. Place intermediate gear in recess of crankcase. See Ill. 2.
3. Put drive gear shaft through bearing in gear case cover as shown in Ill. 3. Be careful not to damage oil seal.
4. Assemble gasket No. 68537 (.015" thick) to gear case dowel pins. Ill. 2.
5. Mount gear case cover by inserting the intermediate gear shaft into gear case cover. Then turn drive gear back and forth until gears mesh and push cover in place. Tap it lightly to get in on dowel pins. Ill. 4.
6. Fasten cover with three bolts at holes marked "X" in Ill. 1.
7. Check end play of intermediate gear by inserting feeler gauge as shown in Ill. 5. End play should be .002" to .008". Note amount of end play.
8. Check end play of drive shaft with indicator as shown in Ill. 6. End play should .002" to .008".
9. Compare end play of drive shaft and intermediate gear. If both have too much end play it can be reduced by removing gasket 68537 and assembling either gasket 27110 or 27111. If they do not have enough end play, add either gasket 27110 or 27111 or both to gasket 68537.
10. If the drive shaft has too much end play and intermediate gear end play is correct, remove gear case cover and place steel shim Part No. 22875 under thrust washer No. 22252. Use a little grease to hold them in place. Ill. 1.
11. Assemble remaining gear cover mounting screws. **DO NOT** put grease into the gear case. The gears are lubricated by oil from the crank case.

#### END PLAY GEAR REDUCTION DRIVE SHAFTS

| ENGINE MODEL | AMOUNT OF END PLAY | HOW TO ADJUST |
|--------------|--------------------|---------------|
| IR-NR-UR-WR  | .002" to .008"     | SEE ABOVE     |

## SPECIAL INFORMATION (Cont'd.)

## To Assemble Gear Reduction Assemblies

## Models AR-BR-KR-ZR-ZZR

These parts are assembled with a .002" to .005" preload on the bearings. In other words, instead of the drive shaft having end play, it will be .002" to .005" tight. See Table 23.

These instructions cover the following part numbers.

|                          |                          |
|--------------------------|--------------------------|
| 290552—Shaft & Cover     | 290573—Gear Case Assy.   |
| 290553—Shaft & Cover     | 290574—Gear Cover Assy.  |
| 290559—Gear Case Assy.   | 290577—Drive Shaft Assy. |
| 290660—Cover Assy.       | 290637—Shaft & Cover     |
| 290563—Gear Case Assy.   | 290638—Drive Shaft Assy. |
| 290564—Cover Assy.       | 290650—Shaft & Cover     |
| 290567—Drive Shaft Assy. | 290651—Drive Shaft Assy. |
| 290571—Shaft & Gear Case | 290835—Shaft & Gear Case |

1. Assemble gear case to crankcase of engine with cap screws and lock-washers. Fig. 205, Ill. 1.

NOTE: Model BR. Be sure that the bronze thrust washer does not fall off the two dowel pins. If it does, the crankshaft end play will be lost. Oil grooves in washer should be toward the crankshaft.

2. If new drive shaft is not equipped with bearing cones, remove bearing cones from old drive shaft. Heat bearing cones in oil so they will expand and slip onto new shaft. Be sure cone is against flange. Ill. 2.
3. Assemble drive shaft and gear with bearing cones by placing a piece of shim stock or card in oil seal to serve as a guide and protect oil seal. Ill. 3. Next place roller bearing cup into recess of gear case cover. Then insert drive shaft through oil seal.

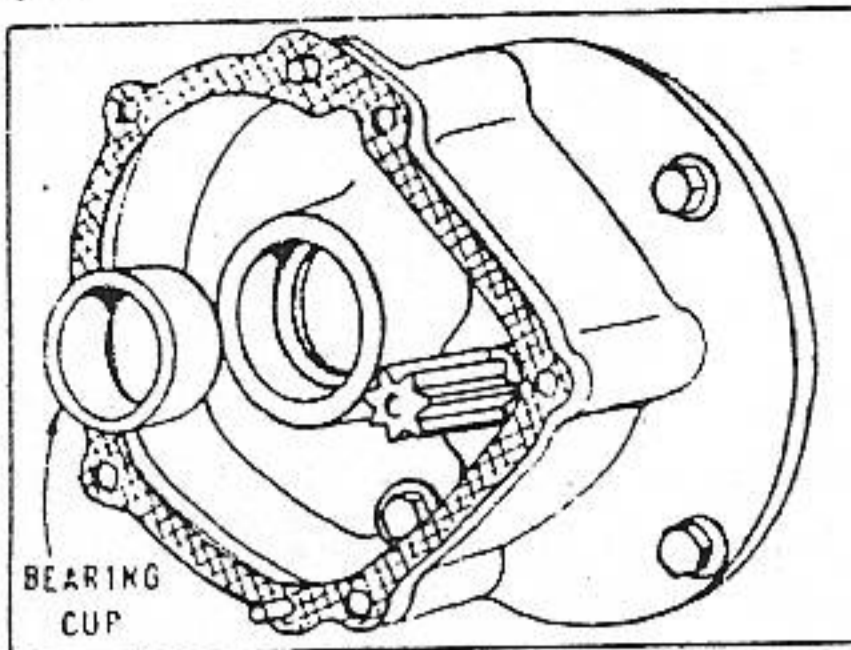
4. Place gear case cover gasket over dowel pins in gear case. See Ill. 1.

5. Assemble drive shaft and gear and gear case cover to gear case with cap screws.
6. Place an indicator at end of drive shaft (See Ill. 5) and pull gear in and out to check end play, while rotating the shaft slowly. After determining end play, remove gear case cover and drive shaft from gear case. Then place as many .003" and .010" shims as required back of gear case cover roller bearing cup. (See Ill. 6 and note below.) The bearings are assembled with a .002" to .005" pre-load. That is the total thickness of the shims must be .002" to .005" more than the end play without shims. Then reassemble parts. If you do not have an indicator, assemble a sprocket or pulley to drive shaft and check end play with a feeler gauge. Ill. 4.

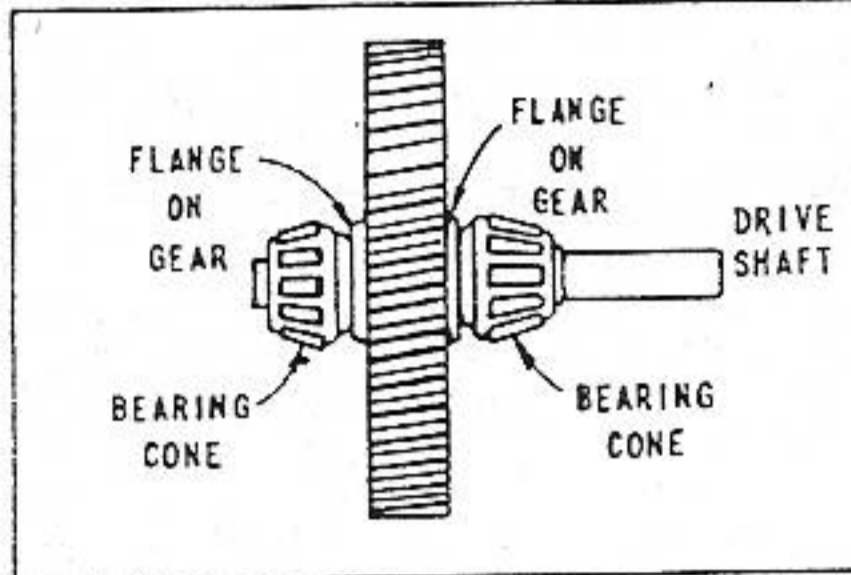
NOTE: To assemble part numbers 290573, 290559 and 290563 gear case assembly follow instructions above except place the shims back of roller bearing cup in gear case. Ill. 1.

TABLE NO. 23  
END PLAY GEAR REDUCTION DRIVE SHAFTS

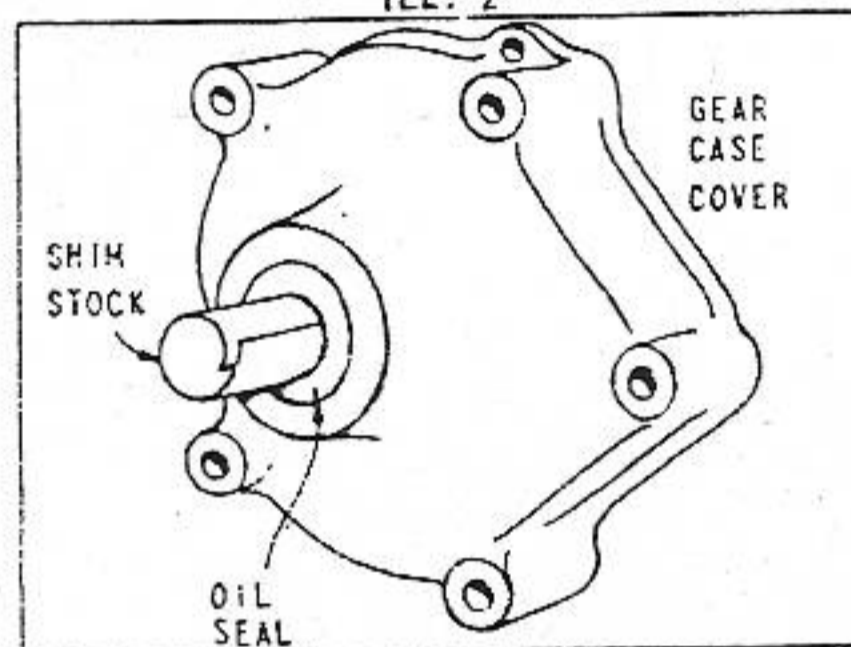
| ENGINE MODEL           | AMOUNT OF END PLAY         | HOW TO ADJUST |
|------------------------|----------------------------|---------------|
| AR-BR-KR-ZR-ZZR        | MINUS .002" to MINUS .005" | SEE ABOVE     |
| NPR6-NSPR6-WIPR6-8R6   | .002" to .032"             | NO ADJ.       |
| NPRI.6-NSPRI.6-WIPRI.6 | .004" to .026"             | NO ADJ.       |
| 9R-14R-23R             | .001" to .014"             | NO ADJ.       |



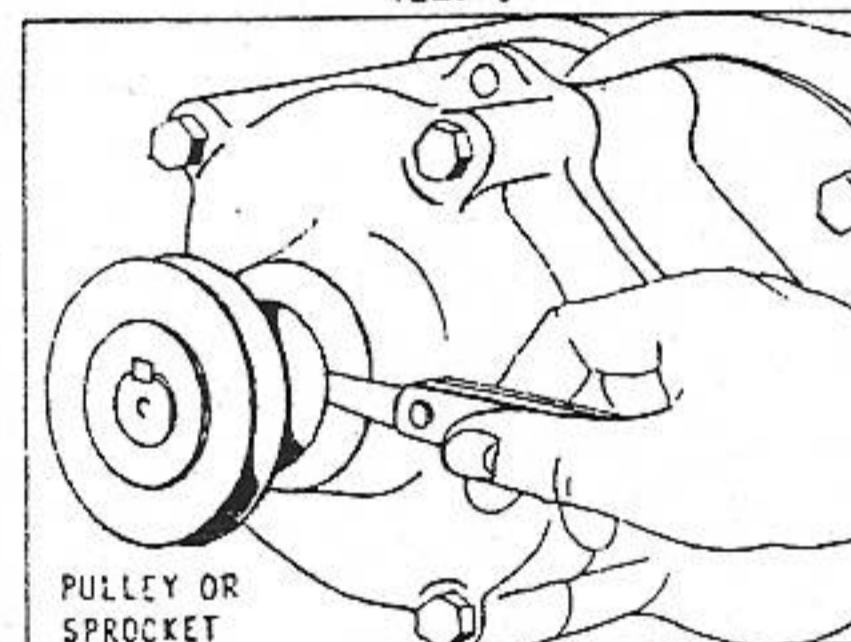
ILL. 1



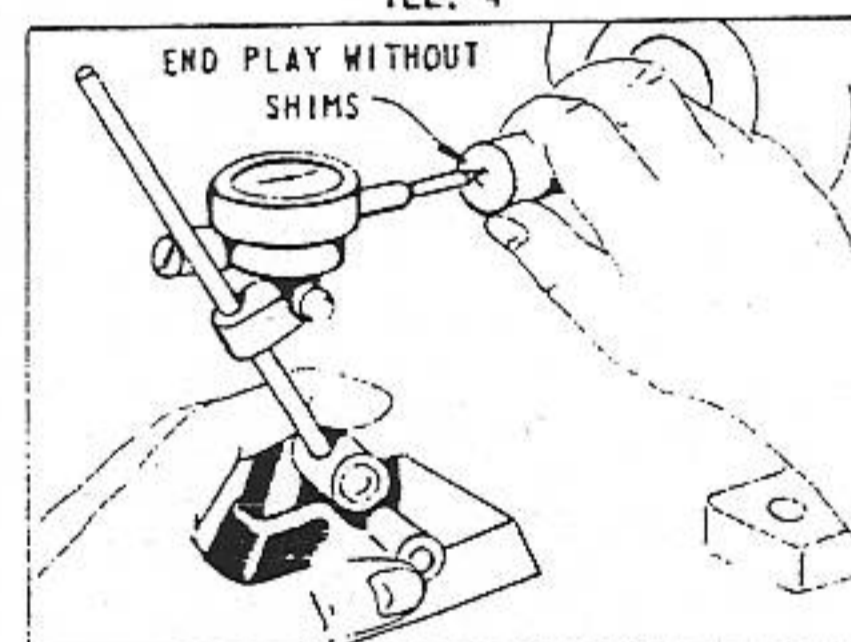
ILL. 2



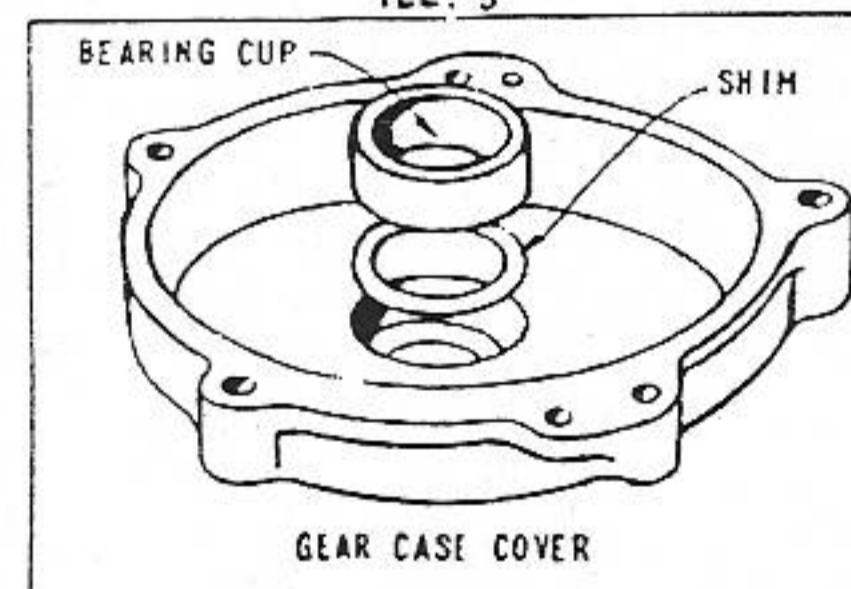
ILL. 3



ILL. 4



ILL. 5



ILL. 6

FIG. 205—REDUCTION GEARS

**Model "WMG" Generator**

IF ARMATURE IS RUBBING ON FIELD POLES, align the engine base plate as follows:

- Drain oil from engine. Turn complete unit upside down and support generator end with block, as shown in Fig. 206, Ill. 1.

Loosen cap screws 1 to 11. Tighten No. 6 (shoulder screw) just enough to hold the base in the adjustment you are about to make. Shift base till armature is centered in the field coil without touching at any point. Use a feeler gauge to get uniform clearance at pole shoes. Now tighten carefully, first, at No. 6, then at No. 11 (dowel pin nut). Recheck to be sure you have armature and field coil separated by uniform clearance. If clearance is O.K. tighten all bolts from 1 to 11. Refill with oil and test.

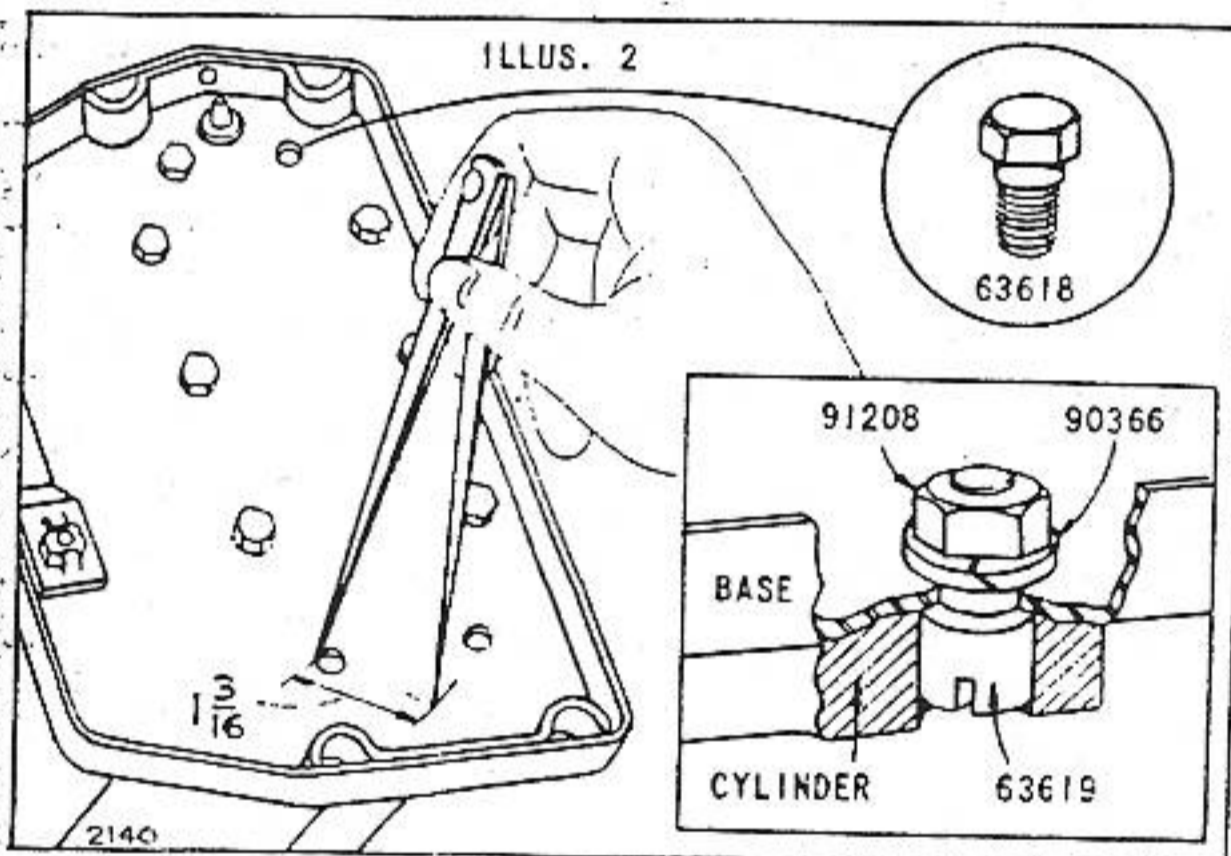
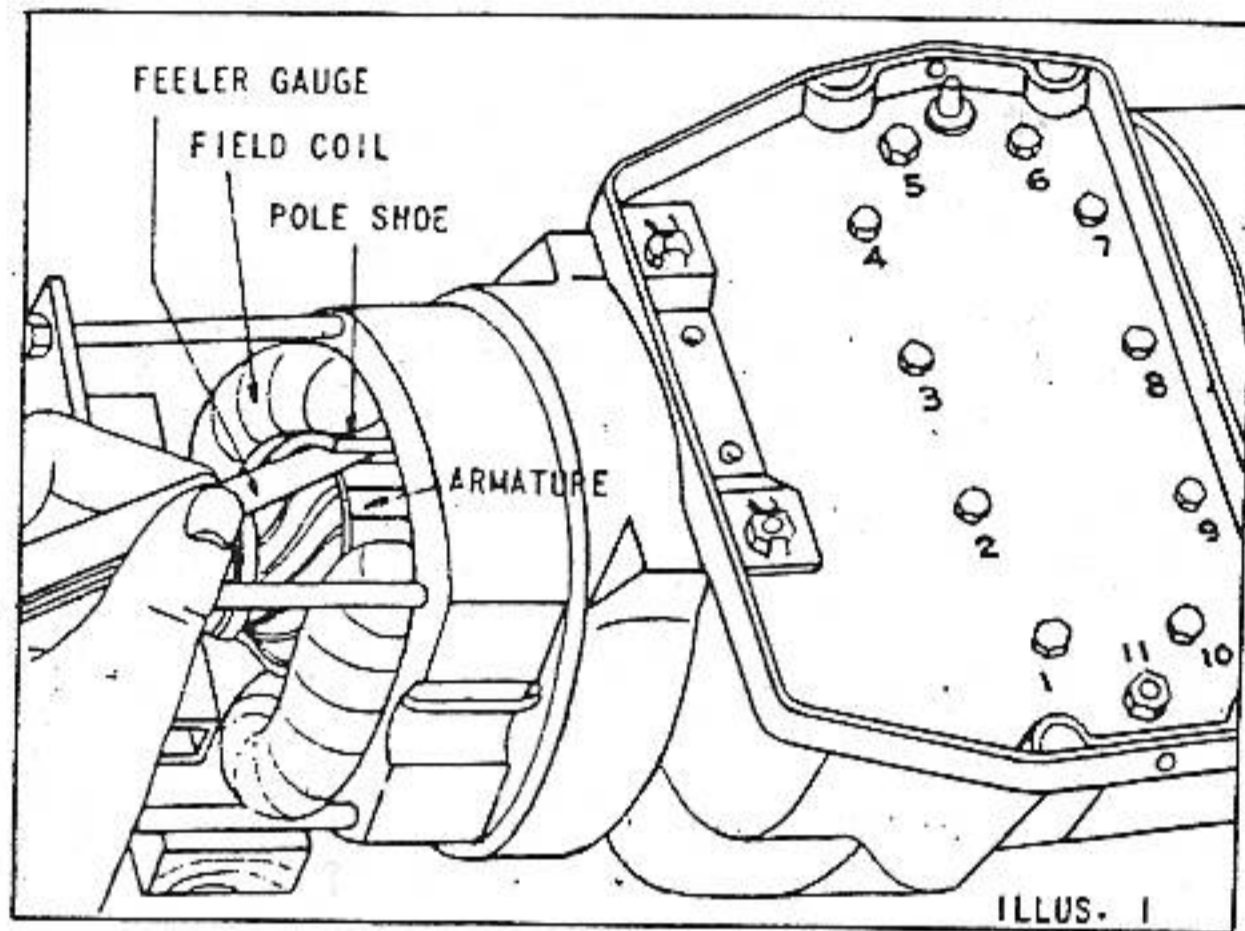


FIG. 206—ALIGNING MODEL "WMG" GENERATOR

**To Align and Dowel**

IF ENGINE IS AN EARLY MODEL (WITHOUT DOWEL PIN) place the unit as explained in preceding article.

Loosen cap screws 1 to 10 and remove screws 1, 6, and 10. Replace No. 6 cap screw with new shoulder screw (No. 63918) then install new dowel pin (No. 63919) at No. 11 after doing the following:

Spread a divider to  $1\frac{3}{16}$ ". Fig. 206. With divider point at the farther side first of No. 1 hole, then No. 10 hole, scratch two arcs to intersect as shown in Fig. 205, Ill. 2 at No. 11. Prick punch at intersection of arcs and drill a  $11/32$ " hole through the base for No. 11 hole.

Now insert dowel pin (No. 63919) into cylinder casting hole with threaded end of pin through bottom of base, and tighten lightly with lockwasher (No. 90366) and nut (No. 91208).

Proceed with aligning as explained in preceding paragraph.

**OIL RETURN VALVES**

An oil leak at the main bearing can usually be corrected by cleaning or replacing oil return valve. The oil return valve is under the bearing in the cylinder and magneto plate. On late model engines the valve is threaded and screwed in place. Earlier models were equipped with cast-in type valves as shown in Fig. 207, Ill. 1, and should be replaced with new type (Part No. 69992) shown in Ill. 2. To remove old style oil return valve, place magneto plate with armature down on a box to support the outer edges. Place end mill tool (Part No. 69054-T4) in drill press and remove entire old oil return valve. In assembling oil return valve (Part No. 69992) be sure the slot of the disc is placed toward the bottom of engine.

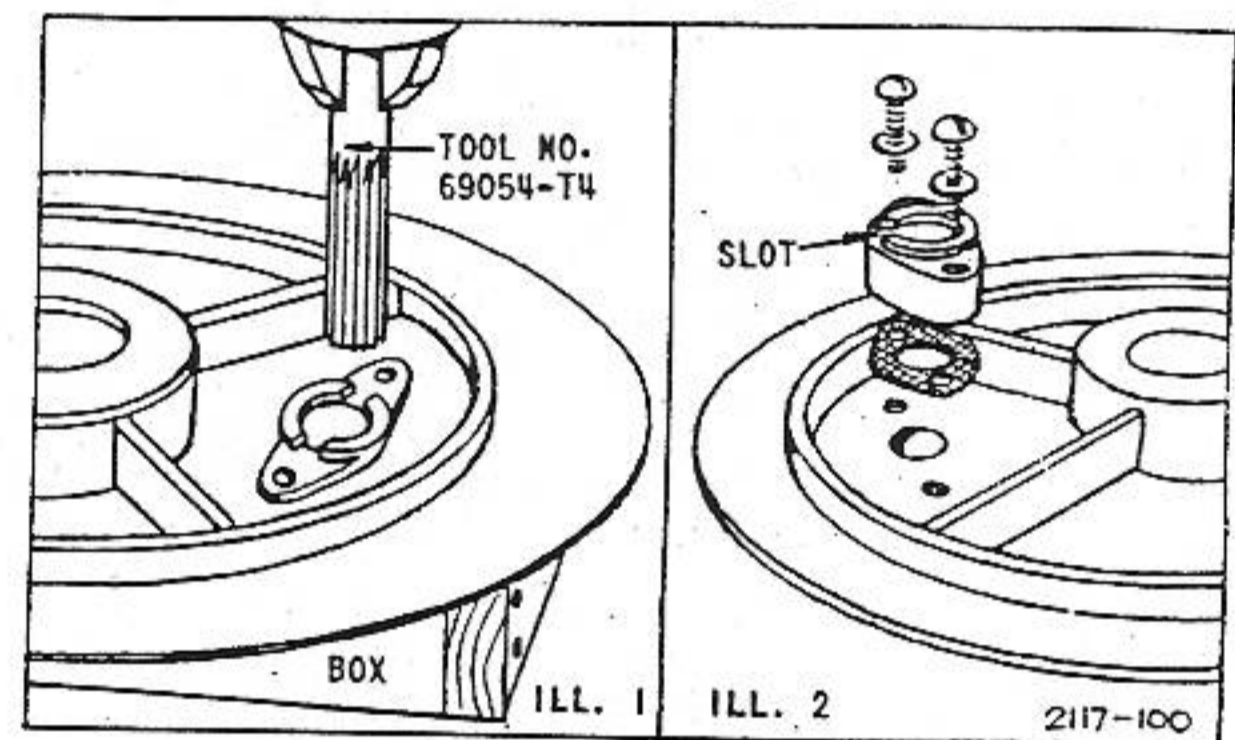


FIG. 207—REPLACING OIL RETURN VALVE

**BREATHERS**

The purpose of the breather is to relieve crankcase pressure and it is important that they be clean to assure proper operation. Some breathers are located inside the valve chamber. Fig. 209. Others are either pressed or screwed into the crankcase. Fig. 208.

**To Clean Breather****Outside Type**

Remove the breather cover with a punch and hammer as shown in Fig. 210. Remove screen and moss.

Clean all parts thoroughly except moss. Discard old moss. For breather with  $1\frac{5}{8}$ " dia. body, replace moss with Keratin Fibre, Part No. 27115. For breathers with  $2\frac{1}{8}$ " dia. body, replace moss with Keratin Fibre, Part No. 27116. Pull Fibre apart enough to remove lumps and prevent it from packing too tightly. Reassemble fibre and retainers as shown in Fig. 208.

On covers measuring  $2\frac{1}{8}$ " use a  $1\frac{1}{4}$ " or  $1\frac{1}{2}$ " pipe coupling.

On covers measuring  $1\frac{5}{8}$ " use a  $1\frac{1}{4}$ " pipe about 7" long. Tap end of pipe or coupling until cover is properly seated on breather body. Do not drive cover with a hammer or other flat surface tool as this is liable to dent cover and prevent proper fit.

(See Following Page)

NOTE: Late models A-B, ZZ-9-14 and 23 engines have a breather with a sucker valve in the breather body. The fibre should be cleaned as shown in other breathers. The valve, however, cannot be repaired and if it does not operate properly the breather should be replaced. Refer to Parts Manual for correct breather part number.

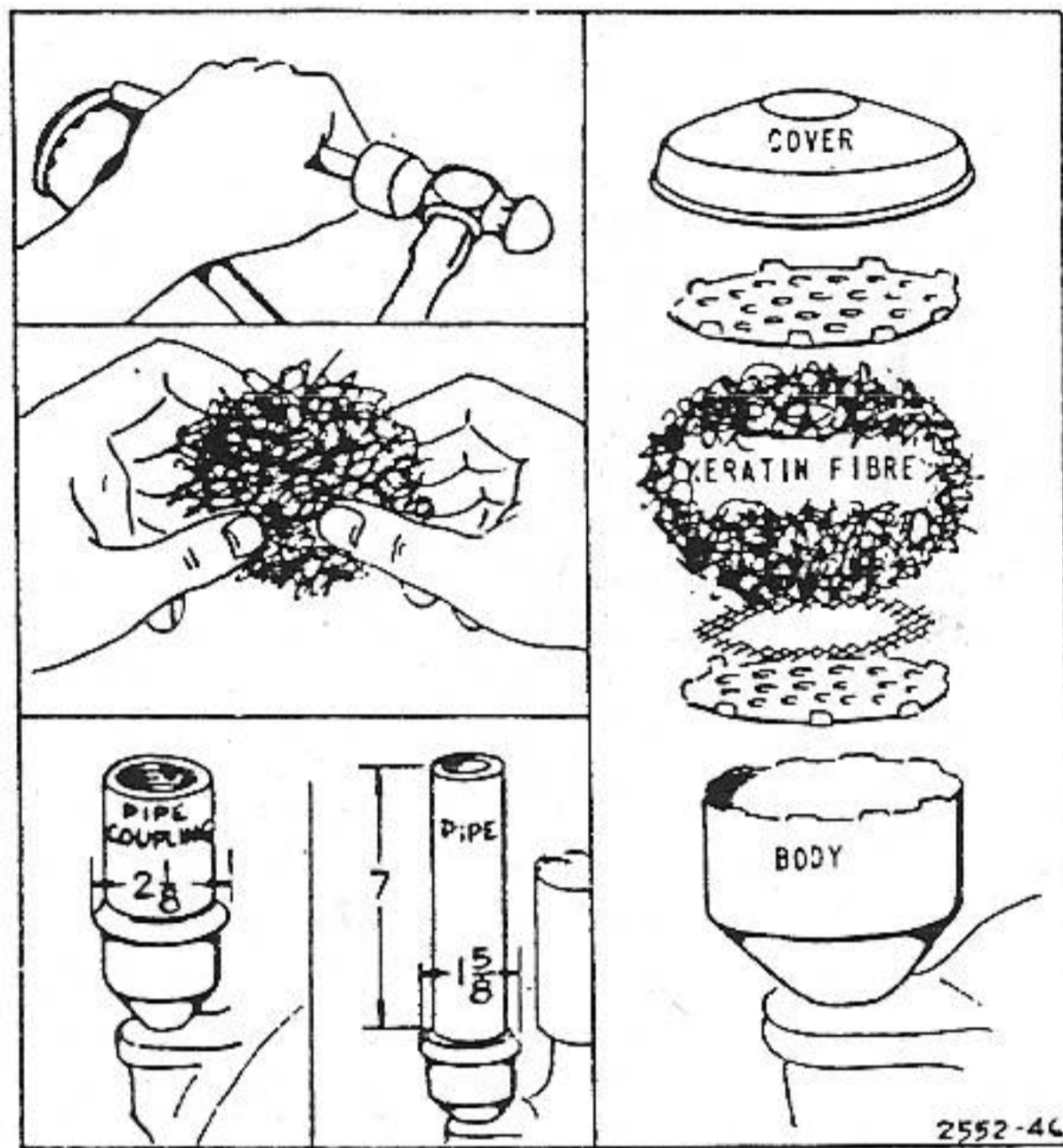


FIG. 208—OUTSIDE BREATHERS

### To Replace Breather and Spray Shield Inside Type

Remove and reassemble the parts in the sequence shown in Fig. 209. If the body has two grooves on the under side, the groove should be parallel to the face of the valve chamber. If one groove, the groove should point toward the front part of valve cover housing at an angle of 45°. If the body has no groove, it can be assembled either way. The spray shield should be assembled about 1/16" from the face of the valve chamber and as close to the bottom of the chamber as the hole in the shield will allow.

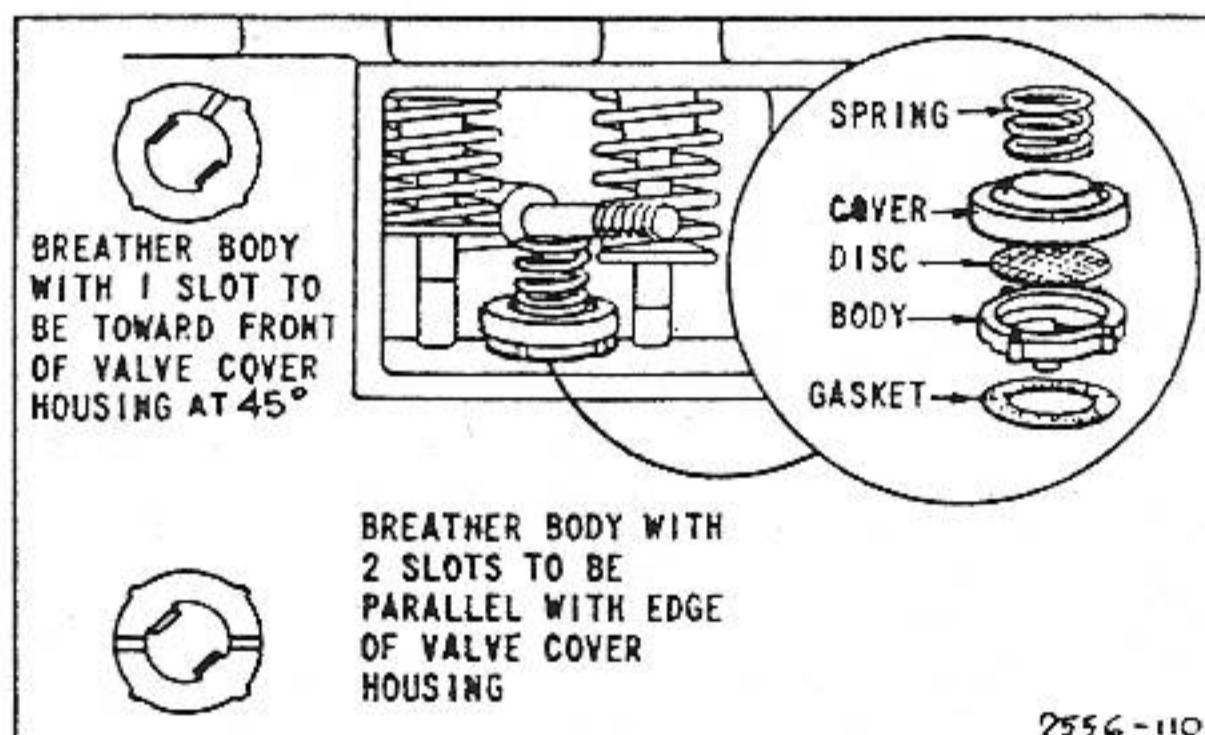


FIG. 209—BREATHER VALVE

### To Replace Breather Outside Type

Many of the breathers are threaded and can be removed and assembled with a flat wrench. Others are pressed into place and can be removed as follows:

Remove fuel tank and bracket and use a punch or rod to drive the breather up and out of cylinder. Fig. 210. If breather body breaks away from the breather sleeve, use a pipe wrench to remove sleeve. Tighten wrench securely on sleeve and turn and lift at the same time.

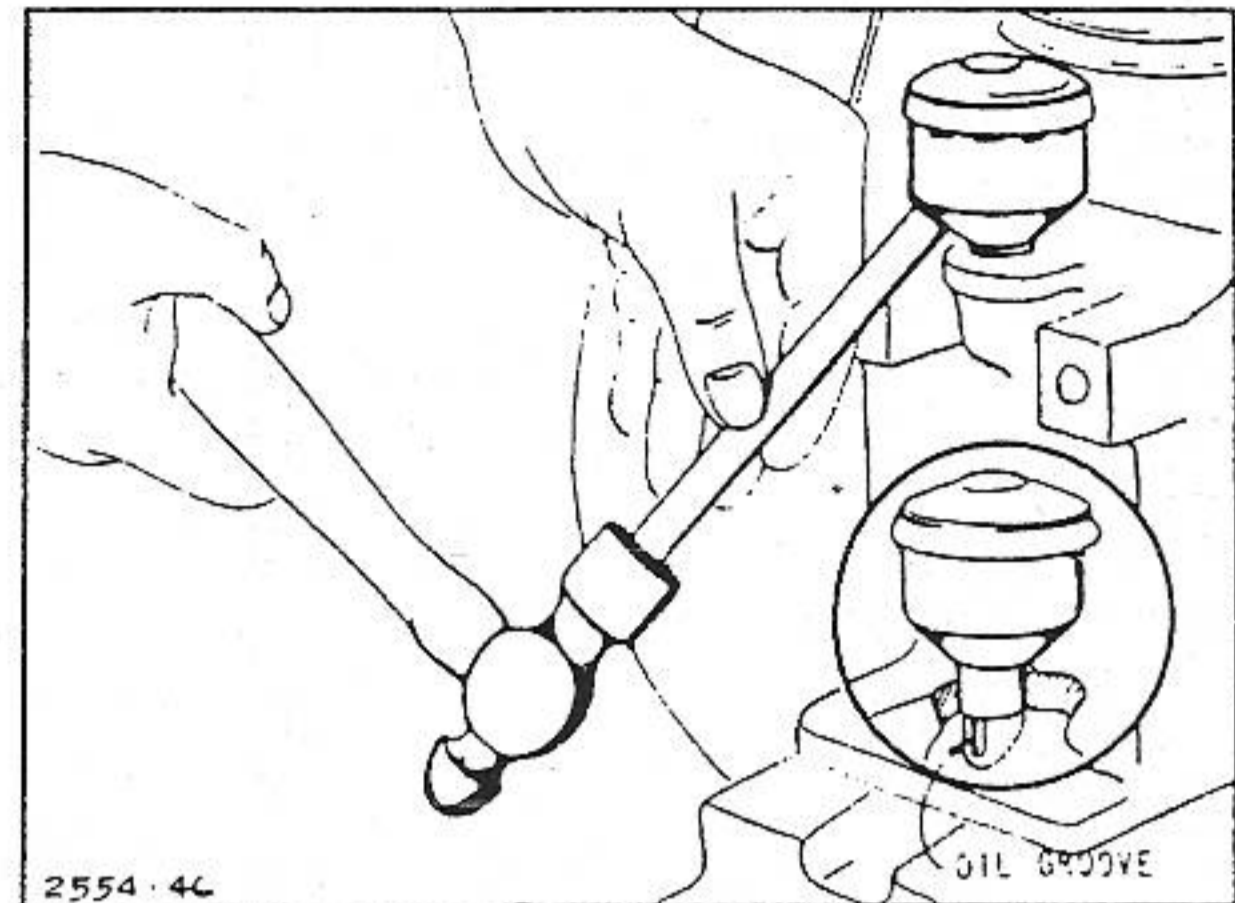


FIG. 210—REMOVING BREATHING

When assembling new breather, apply a coat of shellac to breather mounting sleeve. Insert breather in hole in cylinder and drive it into place using Driving Block, Part No. 69751-T1, Fig. 211, Ill. 2. Be careful not to plug oil return groove in breather sleeve when applying shellac. On Models WM-WMB if the breather body breaks away from the breather sleeve, drive the sleeve down into crankcase with a 3/8" punch. Fig. 211, Ill. 1.

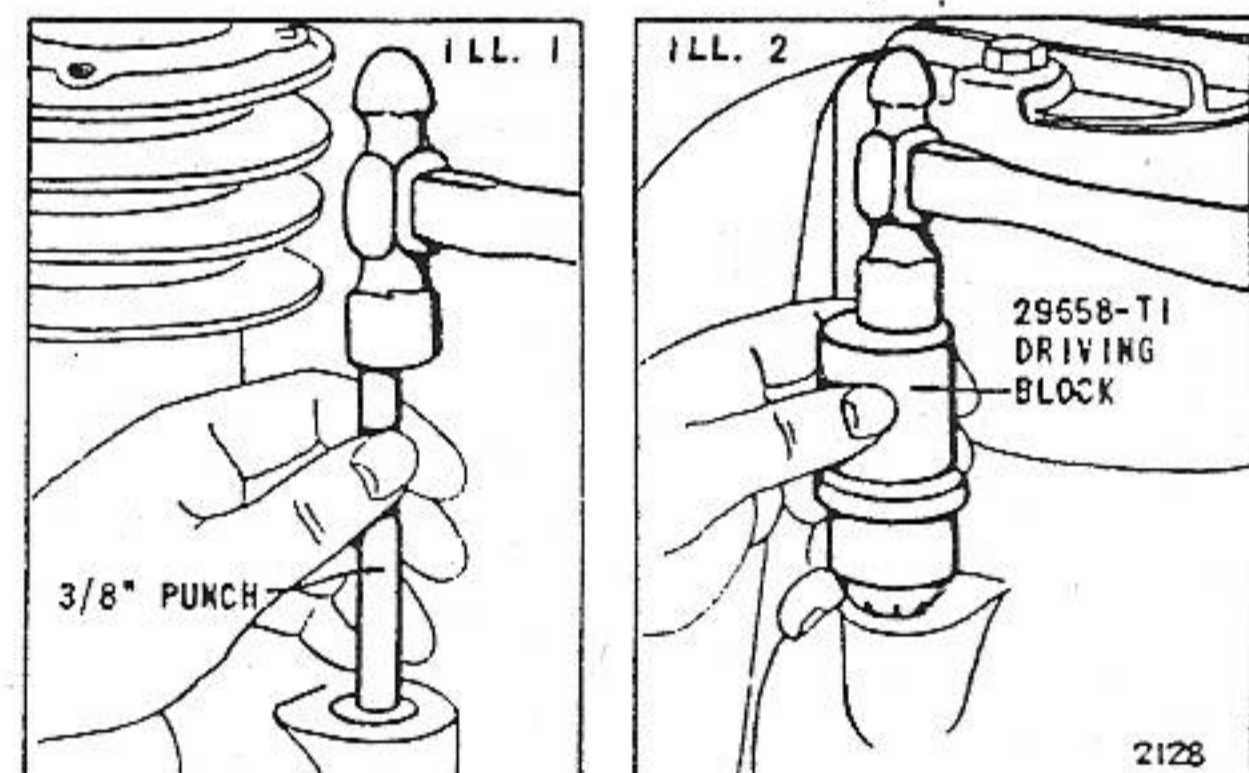


FIG. 211—REPLACING BREATHING

## CHANGE OIL SYSTEM

### Models WM-WMG-PCWM

Each and every one of the above models sent to you for repair or adjustment must be changed from the pump type to splash type oiling system as outlined in the following procedure:

#### Model WM

Drain oil; remove engine base plate. Use 7/16" socket.

#### Model WMG

Drain oil; remove generator assembly from engine base. Use 1/2" open end wrench to take off generator mounting screws. Remove base plate from engine (use same tools as for Model WM). DO NOT loosen base plate dowel nut which keeps engine and generator in alignment.

**Model PCWM**

Drain oil; remove gas tank from engine. Use 1/2" and 3/8" open-end wrenches. Remove base from engine, same as Model WM.

Inspect lower bearing of connecting rod, and if in good shape reassemble rod. DISCARD FILLISTER HEAD CONNECTING ROD SCREW LOCATED NEAREST CARBURETOR SIDE OF ENGINE and install in its place Special Dipper Screw (Part No. 91942) and draw up both screws tight. Fig. 212.

If lower rod bearing is scored, discard rod and install new connecting rod, Part No. 29733, with assembly marks on rod and X on piston boss toward magneto side of engine.

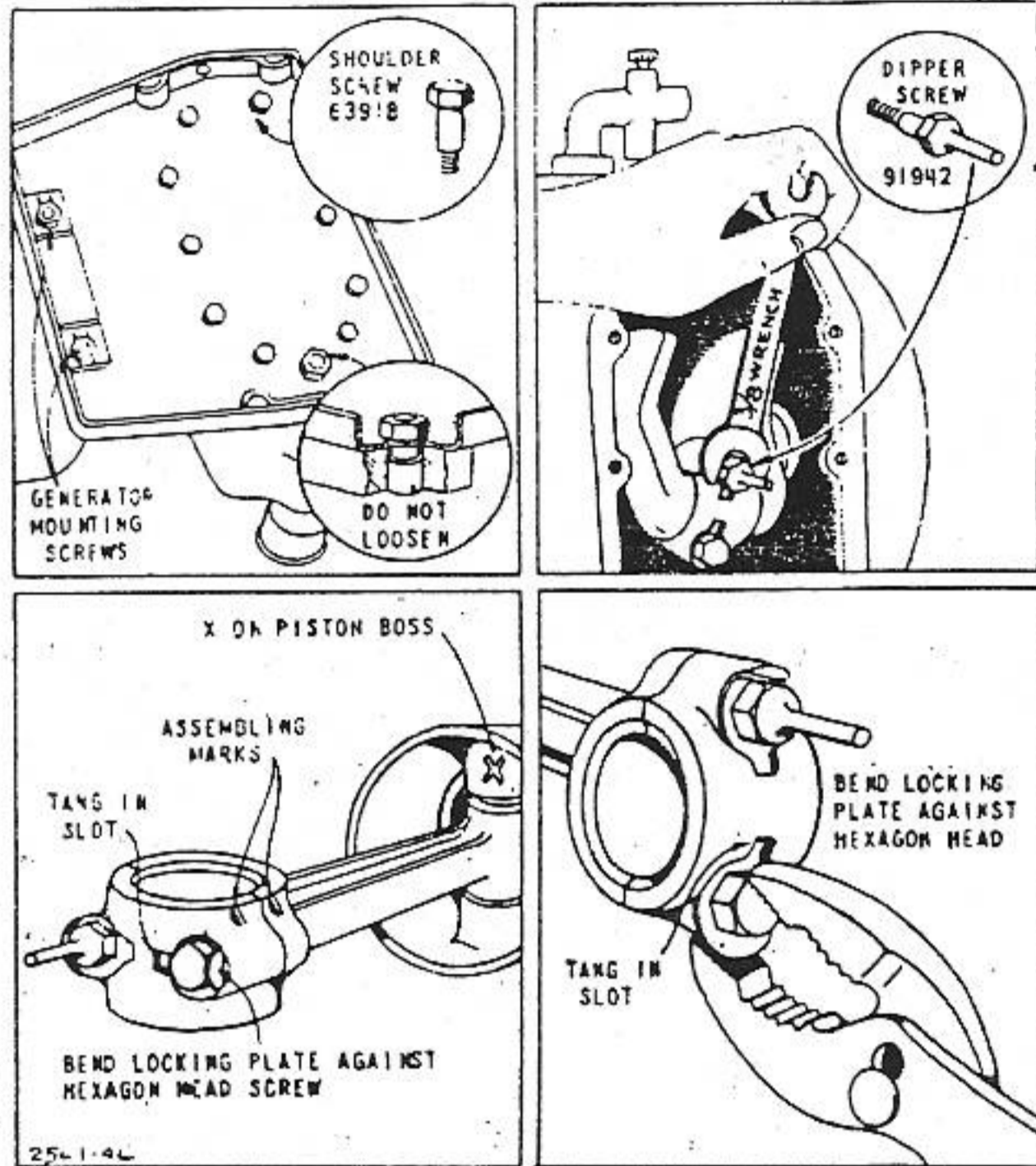


FIG. 212—CHANGING OIL SYSTEM

See that tangs of the connecting rod screw locking plates are in slots. Bend locking plates against hexagon heads with a pair of pliers. Fig. 212.

Install new base plate Part No. 62904 on Models WM or PCWM and Part No. 62974 on Model WMG.

**CHANGE OIL PUMP**

**Models I-IBP-WI-WMI**

The oil pump of each and every Briggs & Stratton Engine Models listed above sent to you for repair or adjustment, must be examined and all old style pumps replaced by the Part Number 99955 as outlined in the following procedure:

Drain Oil; Remove engine base. Remove oil pump from base.

Use 7/16" socket wrench.

To check whether oil pump is old or new style, blow oil out of screen, but *do not remove screen*.

The old style oil pump had a staked-in seat as indicated in Plate Fig. 212 and must be replaced by the new style pump which can be identified by the cast-in seat as shown in Fig. 213.

When assembling new pump to base be sure to install pump plunger and spring from the old pump.

This replacement is to be made on a warranty basis, regardless of the condition of the old pump. Fig. 213.

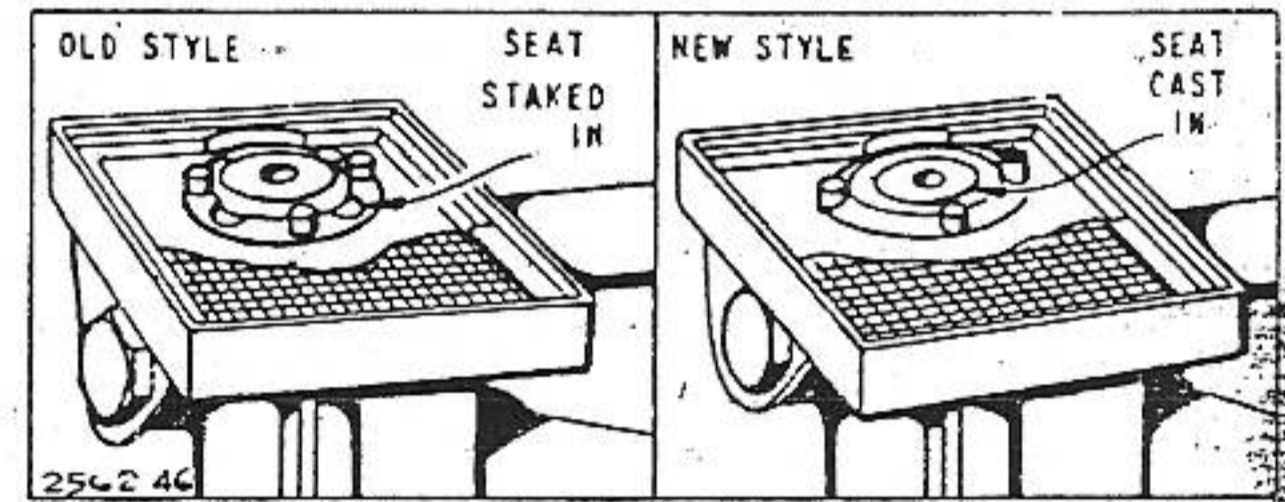


FIG. 213—CHANGING OIL PUMP

another free manual from www.searstractormanuals.com

## TOOLS

The following pages list the special tools used in repairing Briggs & Stratton engines.

Table 24 lists the tools by number and name, and tells what each is used for and on what engine models. Standard tools such as socket, open-end wrenches, etc., however, are not listed.

If a tool in your tool kit is not marked with a part number, it may be identified by comparing it with the illus-

tration and checking its size. Then refer to chart to determine its use.

The plate number reference in last column refers to plates in chapter 12 only — not to plates in prior chapters.

NOTE: Several sizes of bearing drivers and crankcase support jacks are listed which are not supplied by Briggs & Stratton. These can be made in your own shop.

TABLE 24 - BRIGGS &amp; STRATTON MAJOR REPAIR TOOL LIST

| PART NO.     | DESCRIPTION             | FUNCTION   | USED ON MODELS                                   | SEE PLATE |
|--------------|-------------------------|--|--|-----------|
| v*MPJ        | Timing Gauge            | Set Cam Gear Timing                              | PH   | 12        |
| MPJ-T4       | Breaker Timer           | Set Spark Timing                                 | FH-FI-FJ-L-M-PB-Q-R-S-T-W                        | 22        |
| MPJ-T7       | Spark Tester            | Test Spark                                       | All Except 9-14-23                               | 21        |
| MPJ-T9       | Plug Gauge              | Check Magneto Bearing                            | FH-FI-FJ-L-M-PB-Q-R-S-T-W                        | 1         |
| MPJ-T11      | End Play Gauge          | Check End Play of Crankshaft                     | A-B-FH-FI-FJ-H-K-L-M-PB-Q-R-S-T-W-Y-Z-ZZ         | 2         |
| MPJ-T12      | Arbor                   | Hold Magneto Plate in Lathe                      | FH-FI-FJ-L-M-PB-Q-R-S-T-W                        | 4         |
| v13A18-T30   | Line Reaming Fixture    | Guide for Reaming Cam Gear Bearings              | PB   | 12        |
| 21100-T2     | Ratchet Wrench          | Loosen or Tighten Kick Starter Hatchet           | I-N-WI-5-6-8                                     | 29        |
| 21309-T10    | Counterbore             | Counterbore Hole for Valve Guide                 | N-NS-U-6-8                                       | 14        |
| 21309-T11    | Reamer                  | To Ream Hole for Valve Guide                     | N-NS-U-6-8                                       | 14        |
| 21875-T5     | Plug (Part of 66629-T5) | To Hold Connecting Rod to Check Alignment        | 23   | 7         |
| 29020        | Flywheel Puller         | Remove Flywheel                                  | K-Z-ZZ   | 19        |
| 29076-T1     | Crankcase Support Jack  | Strengthen Crankcase - Replacing Gov. Gear Shaft | A-B-K-Z-ZZ                                       | 6         |
| 29076-T2     | Crankcase Support Jack  | Strengthen Crankcase - Replacing Gov. Gear Shaft | L-M  | 6         |
| 29076-T3     | Bushing Driver          | Replace Drive Bearing                            | A-H-PB-Y   | 5         |
| 29157        | Flywheel Puller         | Remove Flywheel                                  | A-E  | 19        |
| 29336-T1     | Crankcase Support Jack  | Strengthen Crankcase - Replacing Gov. Crank Brg. | B  | 6         |
| *29347-T1    | Bushing Driver          | Replace Drive Bearing                            | Q-R-W  | 5         |
| 29593        | Flywheel Puller         | Remove Flywheel                                  | H-Y  | 19        |
| 29654        | Feeler Gauge            | Check Point Gap - Tappet Clearance, etc.         | All Models                                       | 25        |
| 29658-T1     | Breather Driver         | Install Breather                                 | FJ-I-IBP-WI-WM-WMB-WMI                           | 27        |
| 29673-T10    | Plug Gauge              | Check Plunger Hole                               | 8 and All 2" Bore***                             | 16        |
| 29673-T10-2  | Reamer                  | Ream Hole for Plunger Bushing                    | 8 and All 2" Bore***                             | 16        |
| 29673-T10-12 | Bushing Driver          | Install Plunger Bushing                          | 8 and All 2" Bore***                             | 16        |
| 29673-T10-22 | Reamer                  | Ream Bushing for Plunger                         | 8 and All 2" Bore***                             | 16        |
| 29673-T11    | Arbor                   | Hold Magneto Plate in Lathe                      | 8 and All 2" Bore***                             | 4         |
| 29738-T6     | Plug Gauge              | Check Valve Guide                                | FH-FI-8 and All 2" Bore***                       | 18        |
| 29746-T1     | Drill                   | Mill Down Valve Guides                           | 8 and All 2" Bore***                             | 15        |
| 29746-T1-1   | Drill Bushing           | Guide for Drill 29746-T1                         | 8 and All 2" Bore***                             | 15        |
| 29746-T2     | Crankcase Support Jack  | Strengthen Crankcase - Replacing Drive Bearing   | 8 and All 2" Bore***                             | 10        |
| 29746-T3     | Bushing Driver          | Replace Magneto or Drive Bearing                 | FH-FI-FJ-I-IBP-N-M-NS-S-T-U-WI-WM-WMB-WMI-5-6-8  | 5         |
| 60079-T3-2   | Shell Reamer            | Ream Holes for Starter Shaft Bearings            | H-Y  | 9         |
| 60079-T3-3   | Pilot Guide             | Driver for 60079-T3-2 Reamer                     | H-Y  | 9         |
| 60079-T3-11  | Ball                    | Burnish Holes in Bushings                        | H-Y  | 9         |
| 60079-T3-12  | Plunger                 | Bushing Driver - Replace Starter Bearings        | H-Y  | 9         |
| 60079-T3-22  | Cross Bar               | Handle for 60079-T3-3 Pilot                      | H-Y  | 9         |
| 60079-T3-31  | Bushing Support         | Guide for 60079-T3-3 Pilot                       | H-Y  | 9         |
| 60079-T3-32  | Nut                     | Feed Nut for 60079-T3-3 Pilot                    | H-Y  | 9         |
| 60144-T100   | Drill Bushing           | Guide for Drill                                  | A-B-FJ-H-K-L-M-R-S-T-W-Y-Z-ZZ                    | 15        |
| 60144-T101   | Drill                   | Mill Down Valve Guides                           | A-B-FJ-H-K-L-M-R-S-T-W-Y-Z-ZZ                    | 15        |
| 60225-T1-4   | Bushing                 | Pilot Guide for Reaming Magneto Bearing          | B-K  | 8         |
| 60225-T1-14  | Bushing                 | Pilot Guide for Reaming Drive Bearing            | A-B-H-K-Y  | 8         |
| 60225-T1-24  | Shell Reamer            | Ream Magneto Bearing                             | A-B-H-K-Y-Z-ZZ                                   | 8         |
| 60225-T1-34  | Shell Reamer            | Ream Drive Bearing                               | B-K  | 8         |
| 60225-T1-44  | Pilot                   | Driver for All 60225-T1 Reamers                  |  | 8         |
| 60225-T1-54  | Bushing                 | Pilot Guide for Reaming Magneto Bearing          | P with Ball Bearing Drive                        | 8         |
| 60225-T1-64  | Bushing                 | Pilot Guide for Reaming Magneto Bearing          | Z-ZZ   | 8         |
| 60225-T1-74  | Bushing                 | Pilot Guide for Reaming Magneto Bearing          | A-H-Y  | 8         |
| 60225-T1-84  | Shell Reamer            | Ream Drive Bearing                               | A-H-Y  | 8         |
| 60225-T11-94 | Bushing                 | Pilot Guide for Reaming Magneto Bearing          | A with Ball Bearing Drive                        | 8         |
| 60732-T2-14  | Bushing                 | Pilot Guide for Reaming Magneto Bearing          | 8 and All 2" Bore***                             | 8         |
| 60732-T2-24  | Shell Reamer            | Ream Magneto or Drive Bearing                    | 8 and All 2" Bore***                             | 8         |
| 60732-T2-34  | Pilot                   | Driver for All 60732-T2 Reamers                  |  | 8         |
| 60732-T2-44  | Bushing                 | Pilot Guide for Reaming Magneto Bearing          | 1-IBP-N With Ball Bearing Drive                  | 8         |
| 61260-T7     | Reamer                  | Ream Hole for Flywheel Bolt                      | H-Y  | 26        |
| 61348-T1-3   | Guide Puller            | Remove Valve Guides                              | A-B-FJ-H-L-M-R-S-T-W-Y-Z-ZZ                      | 17        |
| 61348-T1-13  | Expansion Pilot         | Pilot Guide for Counterbore for Valve Seat       | 8 and All 2" Bore***                             | 18        |
| 61348-T1-23  | Expansion Pilot         | Pilot Guide for Counterbore for Valve Seat       | A-B-FJ-H-K-L-M-R-S-T-W-Y-Z-ZZ-9-14-23            | 18        |
| 61348-T1-33  | Counterbore             | Drill Hole in Cylinders for Valve Guides         | FJ-H-I-L-M-O-R-S-T-W-Y with Non-removable guides | 14        |
| 61348-T1-43  | Planer Shank            | Driver for Counterbore No. 61348-T1-63 & 73 & 83 |  | 18        |
| 61348-T1-53  | T Handle                | Handle for Planer Shank 61348-T1-43              |  | 18        |
| 61348-T1-63  | Counterbore Cutter      | Counterbore Holes for Valve Seat Inserts         | B-K-R-W-Z-77-14-23                               | 18        |
| 61348-T1-73  | Counterbore Cutter      | Counterbore Holes for Valve Seat Inserts         | A-FJ-H-L-M-S-T-Y-9                               | 18        |
| 61348-T1-83  | Counterbore Cutter      | Counterbore Holes for Valve Seat Inserts         | I-IBP-N-NS-U-WI-WM-WMB-WMI-5-6-8                 | 18        |

TABLE 24 - BRIGGS & STRATTON MAJOR REPAIR TOOL LIST

| PART NO.     | DESCRIPTION                                | FUNCTION  | USED ON MODEL                             | SEE PLATE |
|--------------|--|---|---|-----------|
| 61348-T1-93  | Reamer                                     | Use if 61348-T1-33 Cuts Undersize                 | FJ-H-L-M-Q-R-S-T-W-Y                      | 14        |
| 61348-T1-102 | Knockout Pin                               | Remove Counterbore Cutters from Planer Shank      |   | 1P        |
| 61348-T1-119 | Insert Driver                              | Drive in Valve Seat Inserts                       | All Models                                | 1P        |
| 61348-T1-122 | T Handle                                   | Handle for Expansion Pilot 6134P-T1-13            | All Models                                | 1R        |
| 61348-T1-152 | Guide Puller                               | Use With 61348-T1-3 to Remove Valve Guides        | A-B-FJ-L-M-S-T-W-Z-ZZ                     | 17        |
| 61741-T19    | Flywheel Holder                            | Hold Flywheel While Loosening Nut                 | R and All 2" Bore***                      | 20        |
| 61992-T6-2   | Puller Nut                                 | Remove Valve Seat Inserts                         | A-9                                       | 11        |
| 61992-T6-12  | Puller Nut                                 | Remove Valve Seat Inserts } Part of 290914        | R and All 2" Bore***                      | 11        |
| 61992-T6-22  | Puller Nut                                 | Remove Valve Seat Inserts                         | B-Z-ZZ-14-23                              | 11        |
| 62552-T1     | Bearing Plug Gauge                         | Check Magneto or Drive Bearing                    | R and All 2" Bore***                      | 1         |
| 62744        | Ignition Wrench                            | Adjust Point Gaps                                 | A-B-H-K-Y-Z-ZZ                            | 23        |
| 63821        | Allen Wrench                               | For Set Screws                                    |   | 23        |
| 63897        | Screw Driver                               | To Remove Carburetor Nozzle                       | A-B-9 and All 2" Bore***                  | 29        |
| 63898        | Screw Driver                               | To Remove Carburetor Nozzle                       | B-K-Z-ZZ-14-23                            | 29        |
| 65116-T3     | Bearing Plug Gauge                         | Check Drive Bearing                               | A-H-Y                                     | 1         |
| 65299-2-T1   | Valve Peener                               | Replace Valves                                    | FH-FJ                                     | 20        |
| 66439-T3     | Bearing Plug Gauge                         | Check Drive Bearing                               | H-K-Q-R-W                                 | 1         |
| 66629-T5     | Piston and Connecting Rod Squareness Gauge | Check Connecting Rod and Piston Alignment         | All Models                                | 7         |
| 66629-T5-2   | Plug                                       | Hold Connecting Rod to Check Alignment            | A-FH-FI-FJ-H-L-M-PB-S-T-Y-9               | 7         |
| 66629-T5-3   | Plug                                       | Hold Connecting Rod to Check Alignment            | B-K-Q-R-W-Z-ZZ-14                         | 7         |
| 66629-T5-4   | Plug                                       | Hold Connecting Rod to Check Alignment            | R and All 2" Bore***                      | 7         |
| v67029-T1    | Line Reamer                                | Ream Cam Gear Bearing                             | PB  | 3         |
| v67029-T2    | Bearing Plug Gauge                         | Check Cam Gear Bearing on Magneto Side            | PB  | 3         |
| v69053-T1    | Armature Turning Fixture                   | Hold Magneto in Lathe                             | A-B-F-H-FI-FJ-H-K-L-M-PB-Q-R-S-T-W-Y-Z-ZZ | 13        |
| v69054-T2    | Bearing Line Reamer                        | Ream Magneto and Drive Bearing                    | O-R-W                                     | 3         |
| 69093-T1     | Bearing Driver                             | Replace Magneto and Drive Bearing                 | FH-FI-FJ-L-M-S-T                          | 5         |
| 69093-T4     | Bearing Plug Gauge                         | Check Drive Bearing                               | FH-FI-FJ-L-M-S-T                          | 1         |
| 69094-T4     | Line Reamer                                | Ream Magneto and Drive Bearing                    | FH-FI-FJ-L-M-S-T                          | 3         |
| 69189-T3     | Valve Spring Compressor                    | To Compress Valve Springs                         | All Except R and 2" Bore***               | 29        |
| 69265-T1     | Line Reamer                                | Ream Magneto and Drive Bearings                   | PB  | 3         |
| 69265-T2     | Bearing Plug Gauge                         | Check Drive and Cam Gear Bearings                 | PB  | 1         |
| 69282-T1     | Oil Retainer Driver                        | Install Oil Retainer or Seal                      | All Models                                | 28        |
| 69751-T1     | Breather Driver                            | Install Breather                                  | A-B-H-K-L-M-Q-R-S-T-W-Y-Z-ZZ              | 27        |
| 69821-T3     | Bearing Plug Gauge                         | Check Magneto Bearing                             | A-B-H-K-Y-Z-ZZ                            | 1         |
| 69821-T3-2   | Reamer                                     | Ream Hole for Plunger Bushing                     | A-B-H-K-Y-Z-ZZ                            | 16        |
| 69821-T3-12  | Bushing Driver                             | Install Plunger Bushing                           | A-B-H-K-Y-Z-ZZ                            | 16        |
| 69821-T3-22  | Reamer                                     | Ream Bushing for Plunger                          | A-B-H-K-Y-Z-ZZ                            | 16        |
| 69821-T3-32  | Plug Gauge                                 | Check Plunger Hole                                | A-B-H-K-Y-Z-ZZ                            | 16        |
| 69821-T4     | Arbor                                      | Hold Magneto Plate in Lathe                       | A-B-H-K-Y-Z-ZZ                            | 4         |
| 69829-T19    | Plug Gauge                                 | Check Valve Guide                                 | A-B-FJ-H-K-L-M-Q-R-S-T-W-Z-ZZ-9-14-23     | 18        |
| 69876-T1     | Bearing Driver                             | Replace Magneto Bearing                           | A-B-H-K-Y-Z-ZZ                            | 5         |
| 69935-T1     | Crankcase Support Jack                     | Strengthen Crankcase - Replace Gov. Crank Bearing | K-Z-ZZ                                    | 6         |
| 95301-T1     | End Play Gauge                             | Check End Play of Crankshaft                      | R and All 2" Bore***                      | 2         |
| 290914       | Valve Insert Puller Assembly               |   | All Models                                | 11        |
| 291227-T8    | Plug Gauge                                 | Check Bushing in Crankcase or Bearing Support     | 9-14-23                                   | 24        |
| 291547       | Flywheel Puller                            | Remove Flywheel                                   | 9-14-23                                   | 10        |

Items with Footnote markings may be in your tool kit. If so, use them as shown. If you do not have them follow directions below.

\*Not Supplied. To be made by Central Service Distributors. Necessary dimensions are given in the respective plates.

vNo longer available. Use inside micrometer to check bearing. If it is larger than C end of gauge as shown in Plate 1, the bearing should be replaced.

vvNo longer available. If replacement of bearing is necessary, send crankcase to factory for reaming.

v\*See directions for timing in Tune-up Instructions.

v\*\*Make steel bushing as shown and use instead of three legged plate on Y type 4 hole mounting magnetos. Drill 1/4" hole in fixture to form slot for oil deflector.

\*\*\*2" bore includes I-IBP-N-NS-U-WJ-WM-WMI-WMI 5-6

NO. 291661 TOOL KIT  
(Consists of the following tools)

| PART NO.     | DESCRIPTION                    | MODELS USED ON               |
|--------------|--------------------------------|------------------------------|
| M1-T7        | Spark Tester                   | All Models                   |
| 29020        | Wheel Puller                   | K-Z-ZZ                       |
| 29157        | Wheel Puller                   | A-B                          |
| 29193        | Wheel Puller                   | H-Y                          |
| 29654        | Feeler Gauge                   | All Models                   |
| 29658-T1     | Breather Driver                | FJ-I-IF-WJ-WM-WMI            |
| 29673-T10    | Plug Gauge                     | R and all 2" bore*           |
| 29673-T10-2  | Contact Plunger Hole Reamer    | R and all 2" bore*           |
| 29673-T10-12 | Bushing Driver                 | R and all 2" bore*           |
| 29673-T10-22 | Contact Plunger Bushing Reamer | R and all 2" bore*           |
| 61741-T19    | Flywheel Holder                | R and all 2" bore*           |
| 62744        | Ignition Wrench (2 in kit)     | A-B-H-K-Y-Z-ZZ               |
| 63821        | Allen Wrench                   | A-R and all 2" bore*         |
| 63897        | Screw Driver                   | A-R-9 and all 2" bore*       |
| 63898        | Screw Driver                   | B-K-ZZ-14-23                 |
| 69189-T3     | Spring Compressor              | All except 2" bore and R*    |
| 69751-T1     | Breather Driver                | A-B-H-K-L-M-Q-R-S-T-W-Y-Z-ZZ |
| 69821-T3-2   | Contact Plunger Hole Reamer    | A-B-H-K-Y-Z-ZZ               |
| 69821-T3-12  | Bushing Driver                 | A-B-H-K-Y-Z-ZZ               |
| 69821-T3-22  | Contact Plunger Bushing Reamer | A-B-H-K-Y-Z-ZZ               |
| 69821-T3-32  | Plug Gauge                     | A-B-H-K-Y-Z-ZZ               |
| 291547       | Wheel Puller                   | 9-14-23                      |

NO. 291694 CRANKSHAFT BUSHING REAMING SET  
(Consists of the following tools)

| PART NO.    | DESCRIPTION        | MODELS USED ON                             |
|-------------|--------------------|--|
| 60225-T1-4  | Bushing            | B-K  |
| 60225-T1-14 | Bushing            | A-R-H-K-Y                                  |
| 60225-T1-24 | Shell Reamer       | A-B-H-K-Y-Z-ZZ                             |
| 60225-T1-34 | Shell Reamer       | B-K  |
| 60225-T1-44 | Pilot              |  |
| 60225-T1-54 | Bushing            | R with ball bearing drive                  |
| 60225-T1-64 | Bushing            | Z-ZZ with ball bearing drive               |
| 60225-T1-74 | Bushing            | A-H-Y                                      |
| 60225-T1-84 | Shell Reamer       | A-H-Y                                      |
| 60225-T1-94 | Bushing            | A with ball bearing drive                  |
| 60732-T2-14 | Bushing            | R and all 2" bore*                         |
| 60732-T2-24 | Shell Reamer       | R and all 2" bore*                         |
| 60732-T2-34 | Pilot              |  |
| 60732-T2-44 | Bushing            | R and all 2" bore with ball bearing drive* |
| 62552-T1    | Bearing Plug Gauge | R and all 2" bore*                         |
| 65116-T3    | Bearing Plug Gauge | A-H-Y                                      |
| 66439-T3    | Bearing Plug Gauge | B-K  |
| 69821-T3    | Bearing Plug Gauge | A-B-H-K-Y-Z-ZZ                             |

\*2" bore includes Models I-IBP-N-NS-U-WJ-WM-WMI-WMI 5-6

TABLE 24 - BRIGGS & STRATTON MAJOR REPAIR TOOL LIST

**PLATE 1 PLUG GAUGES**

GO NO GO  
IF GAUGE DOES NOT HAVE "C" END MEASURE WEAR WITH A MICROMETER

| PART NO. | A             | B             | C             |
|----------|---------------|---------------|---------------|
| MPJ-T9   | .9700-.9698   | .9707-.9705   | .9717-.9715   |
| 62552-T1 | .8764         | .8770         | .8780         |
| 65116-T3 | .9955-.9954   | .9961-.9960   | .9971-.9970   |
| 66439-T3 | 1.1255-1.1254 | 1.1261-1.1260 | 1.1271-1.1270 |
| 67029-T2 | .7500-.7498   | .7507-.7505   | .7517-.7515   |
| 69093-T4 | .8750-.8748   | .8757-.8755   | .8767-.8765   |
| 69265-T2 | 1.0000-.9998  | 1.0007-1.0005 | 1.0017-1.0015 |
| 69821-T3 | 1.0955-1.0954 | 1.0961-1.0960 | 1.0971-1.0970 |

**PLATE 7 PISTON & CONN. ROD SQUARENESS GAUGE**

| PART NO.   | A           |
|------------|-------------|
| 66629-T5-2 | .8750-.8748 |
| 66629-T5-3 | 1.000-.9998 |
| 66629-T5-4 | .7509-.7507 |

**PLATE 2 END PLAY GAUGE**

| PART NO. | A      |
|----------|--------|
| MPJ-T11  | 4 1/2" |
| 95301-T1 | 4"     |

**PLATE 8 BEARING REAMERS**

| FIG | PART NO.    | A             |
|-----|-------------|---------------|
| 1   | 60225-T1-44 | .5000-.4995   |
| 1   | 60732-T2-34 | .4375-.4370   |
| 2   | 60225-T1-24 | 1.096-1.0955  |
| 2   | 60225-T1-34 | 1.126-1.1255  |
| 2   | 60225-T1-84 | .9960-.9955   |
| 2   | 60732-T2-24 | .8770-.8768   |
| 3   | 60225-T1-4  | 1.1250-1.1245 |
| 3   | 60225-T1-14 | 1.0950-1.0945 |
| 3   | 60225-T1-74 | .9950-.9945   |
| 3   | 60732-T2-14 | .8759-.8754   |
| 4   | 60225-T1-54 | 2.4413-2.4408 |
| 4   | 60225-T1-64 | 2.8350-2.8345 |
| 4   | 60225-T1-94 | 2.0474-2.0470 |
| 4   | 60732-T2-44 | 1.8504-1.8500 |

**PLATE 3 LINE REAMERS**

| PART NO. | LENGTH   | A             | B           |
|----------|----------|---------------|-------------|
| 60079-T2 | 12-3/8"  | 1.0962-1.0959 | .9962-.9959 |
| 67029-T3 | 8 1/4"   | .9999-.9997   | .7505-.7502 |
| 69054-T2 | 11-1/16" | 1.1260-1.1258 | .9705-.9702 |
| 69094-T4 | 11 1/2"  | .9705-.9703   | .8755-.8753 |
| 69265-T1 | 11-1/16" | 1.0005-1.0003 | .9710-.9708 |

**PLATE 9 STARTER SHAFT BUSHING REAMER**

60079-T3-22 60079-T3-3 60079-T3-32  
60079-T3-12 60079-T3-11 60079-T3-2  
60079-T3-31

**PLATE 4 ARBOR**

| PART NO.  | A     | B         |
|-----------|-------|-----------|
| MPJ-T12   | .974  | .969-.968 |
| 69821-T4  | 1.099 | 1.093     |
| 29673-T11 | .8795 | .874      |

**PLATE 5 BUSHING DRIVERS**

COLD FINISH STEEL

| PART NO. | A           | B           | C      | D       |
|----------|-------------|-------------|--------|---------|
| 29076-T3 | .990-.985   | 1.110-1.100 | 3-3/4  | 5-3/8   |
| 29347-T1 | 1.125-1.120 | 1.25        | 1-1/2  | 4       |
| 29746-T3 | .860-.855   | .971-.966   | 3-3/4  | 5-1/2   |
| 69093-T1 | .860-.850   | 1.110-1.100 | 3-3/4  | 5-13/32 |
| 69876-T1 | 1.073-1.068 | 1.215-1.210 | 1-7/16 | 4       |

**PLATE 10 29746-T2 CRANKCASE SUPPORT**

**PLATE 11 290914 VALVE INSERT PULLER**

**PLATE 6 CRANKCASE SUPPORTS**

| PART NO. | A      | B     | C     |
|----------|--------|-------|-------|
| 29076-T1 | 3-1/4  | 1-3/8 | 7/8   |
| 29076-T2 | 5-7/8  | 1-1/2 | 1-1/2 |
| 29336-T1 | 7-1/16 | 1-1/2 | 1-1/2 |
| 49935-T1 | 8-1/8  | 1-1/2 | 1-1/2 |

**PLATE 12 13A18-T30 LINE REAMING TOOL**

PLUG  
MPJ  
TIMING GAUGE

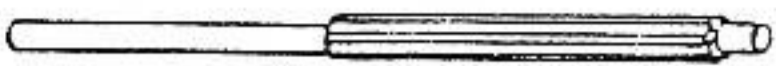
**PLATE 13 69053-T1 ARMATURE TURNING FIXTURE**


another free manual from www.searstractormanuals.com

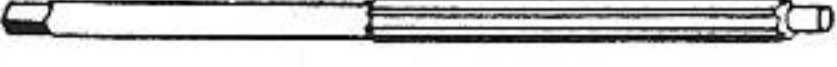
TOOLS (Cont'd)

TABLE 24 - BRIGGS & STRATTON MAJOR REPAIR TOOL LIST

PLATE 14

61348-T1-33 

61348-T1-93 

21309-T10 


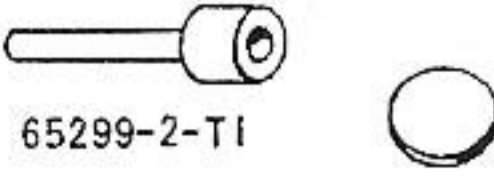
21309-T11 

PLATE 20

65299-2-T1 

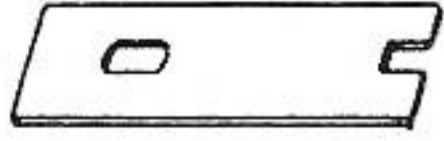
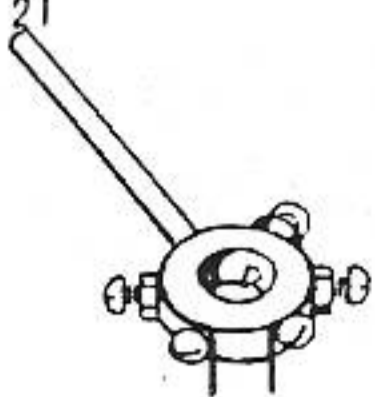



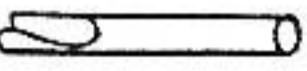
PLATE 21




MPJT7

PLATE 15

29746-T1-1 

60144-T101 

60144-T100 



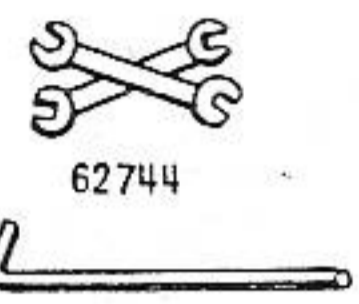
29746-T1 

PLATE 22



MPJT4


PLATE 23

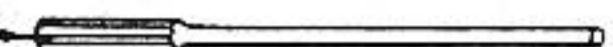


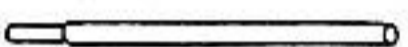
62744

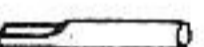
63821


PLATE 16

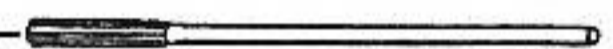
69821-T3-2 

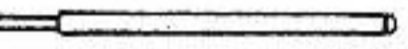
69821-T3-22 

69821-T3-12 

69821-T3-32 

29673-T10-2 

29673-T10-22 

29673-T10-12 


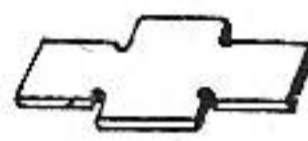

29673-T10 

PLATE 24



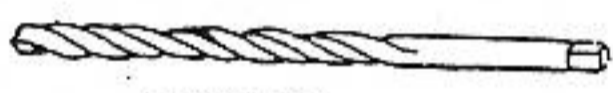
291227-T8

PLATE 25



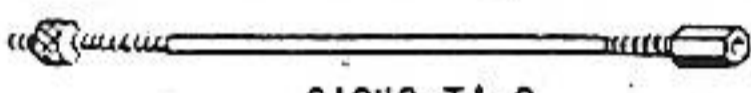
29654

PLATE 26

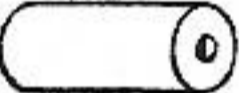


61260-T7

PLATE 17




61348-T1-3




61348-T1-152

PLATE 27




69751-T1



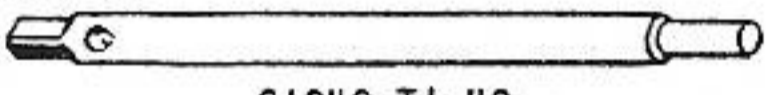
29658-T1

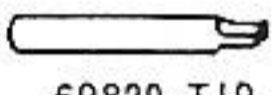
PLATE 28

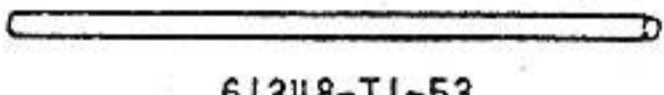


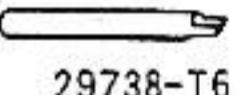
69282-T1

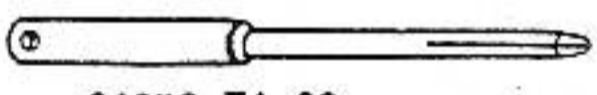
PLATE 18

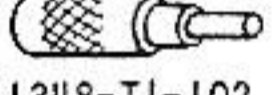
61348-T1-43 

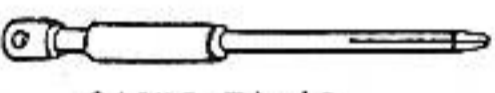
69829-T19 

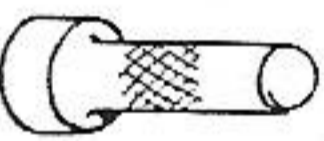
61348-T1-53 

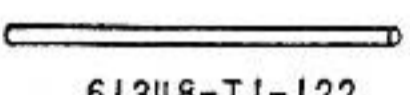
29738-T6 

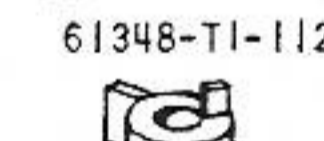
61348-T1-23 


61348-T1-102 


61348-T1-13 

61348-T1-112 

61348-T1-122 

61348-T1-112 

61348-T1-83 

61348-T1-73 


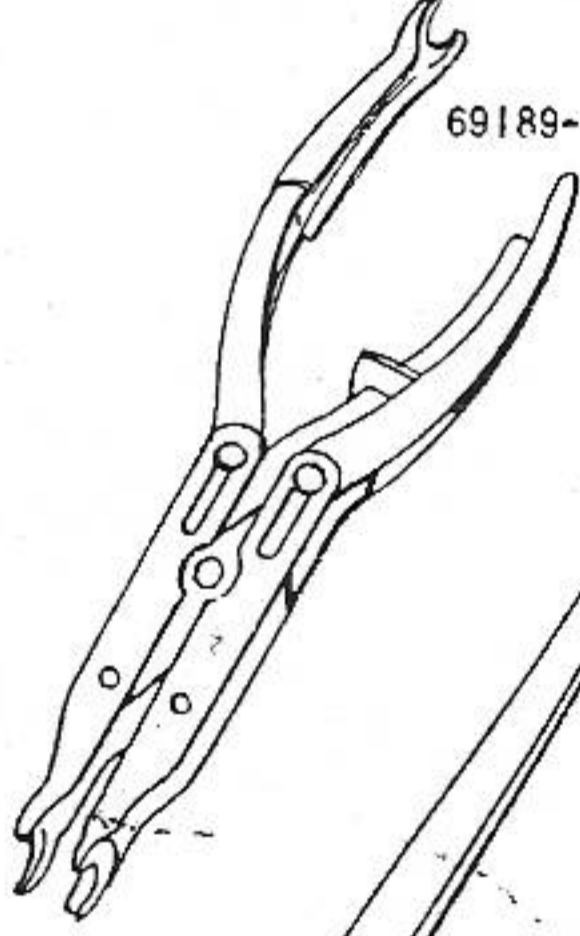
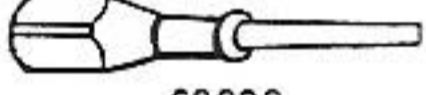
61348-T1-63 

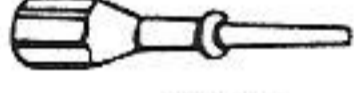
PLATE 29



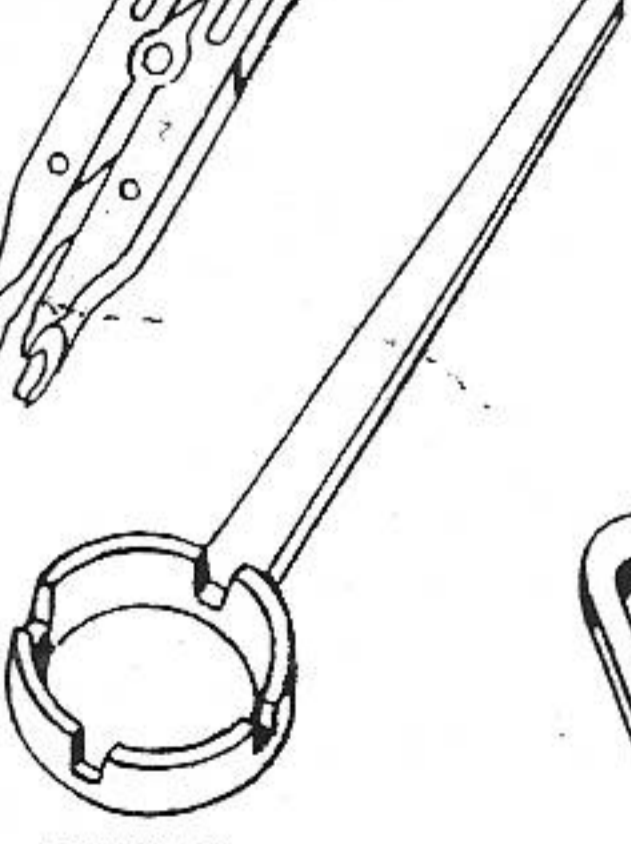
69189-T3



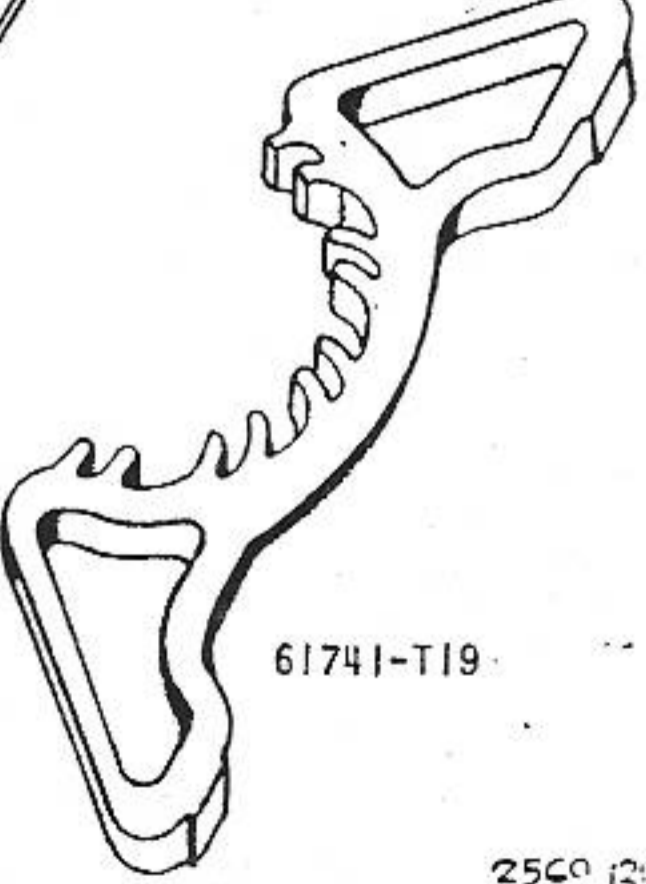
63898



63897

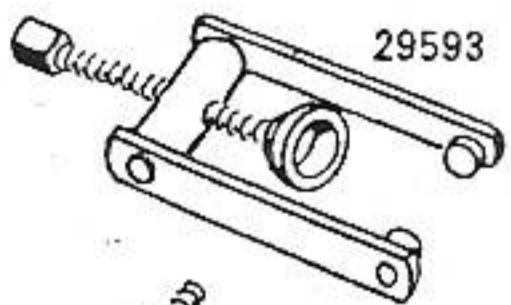


21100-T2

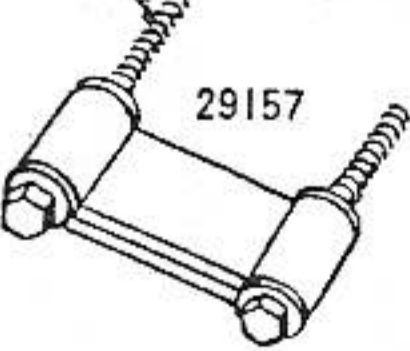


61741-T19

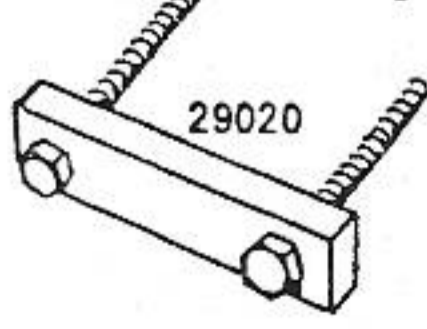
PLATE 19



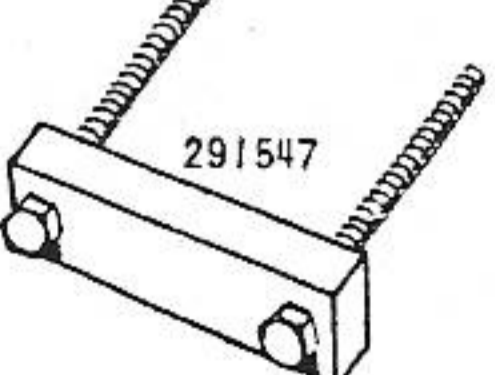
29593



29157



29020

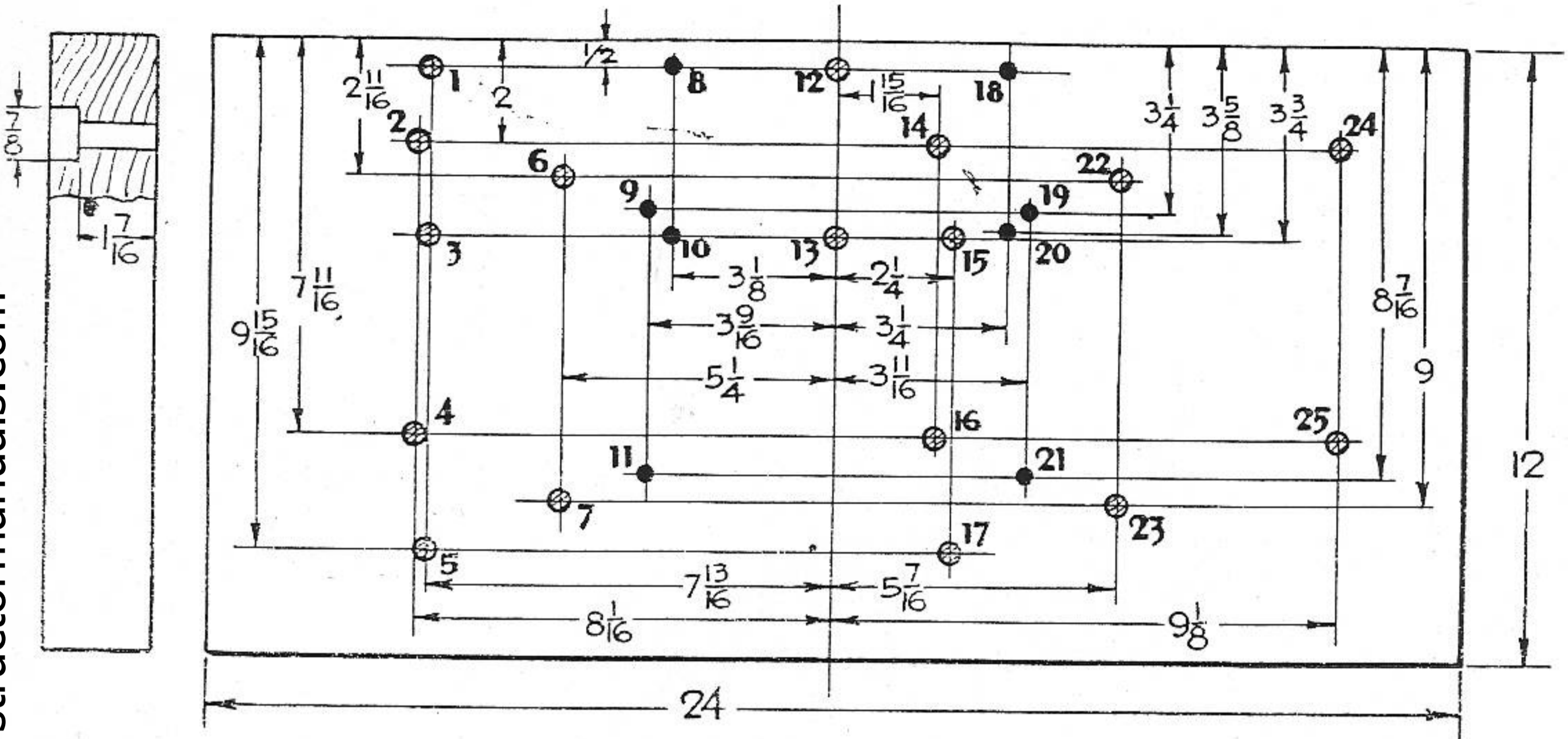


291547

TOOLS (Cont'd)

INSTRUCTIONS FOR MAKING AND USING 27435 ENGINE MOUNTING BOARD  
USED FOR MAKING RUNNING-IN TEST ON BRIGGS & STRATTON ENGINES

1 - 2x12x24 Hardwood Plank. Top & Sides Finished. Holes Numbered 8-9-10-11-18-19-20-21 are 5/16" dia. with Counterbore as Shown. 1-2-3-4-5-6-7-12-13-14-15-16-17-22-23-24-25 are 3/8" dia. also Counterbored as shown.



| MODEL            | USE HOLES   | CARRIAGE BOLTS     | MISC.             |
|------------------|-------------|--------------------|-------------------|
| A                | 2-4-14-16   | 4 - 3/8" x 2 1/2"  |                   |
| 9                | 2-4-14-16   | 4 - 3/8" x 2 1/2"  |                   |
| B                | 2-4-14-16   | 4 - 3/8" x 2 1/2"  |                   |
| FH-FI            | 14-16-24-25 | 4 - 3/8" x 2 1/2"  |                   |
| FJ               | 14-16-24-25 | 4 - 3/8" x 2 1/2"  |                   |
| H                | 1-3-12-13   | 4 - 3/8" x 2 3/4"  | 4 - 63092 Spacers |
| I - Narrow Base  | 8-10-18-20  | 4 - 5/16" x 2 1/2" |                   |
| I - Wide Base    | 9-11-19-21  | 4 - 5/16" x 2 1/2" |                   |
| K                | 6-7-22-23   | 4 - 3/8" x 2 1/2"  |                   |
| L                | 1-3-12-13   | 4 - 3/8" x 2 3/4"  | 4 - 63092 Spacers |
| M                | 14-16-24-25 | 4 - 3/8" x 2 1/2"  |                   |
| N - Narrow Base  | 8-10-18-20  | 4 - 5/16" x 2 1/2" |                   |
| N - Wide Base    | 9-11-19-21  | 4 - 5/16" x 2 1/2" |                   |
| O                | 6-7-22-23   | 4 - 3/8" x 2 1/2"  |                   |
| R                | 6-7-22-23   | 4 - 3/8" x 2 1/2"  |                   |
| S                | 14-16-24-25 | 4 - 3/8" x 2 1/2"  |                   |
| T                | 1-3-12-13   | 4 - 3/8" x 2 3/4"  | 4 - 63092 Spacers |
| U - Narrow Base  | 8-10-18-20  | 4 - 5/16" x 2 1/2" |                   |
| U - Wide Base    | 9-11-19-21  | 4 - 5/16" x 2 1/2" |                   |
| W                | 6-7-22-23   | 4 - 3/8" x 2 1/2"  |                   |
| WM-WMB           | 8-10-18-20  | 4 - 5/16" x 2 1/2" |                   |
| WVG              | 8-10-18-20  | 4 - 5/16" x 2 1/2" |                   |
| WMI              | 9-11-19-21  | 4 - 5/16" x 2 1/2" |                   |
| Y                | 1-3-12-13   | 4 - 3/8" x 2 3/4"  | 4 - 63092 Spacers |
| Z                | 6-7-22-23   | 4 - 3/8" x 2 1/2"  |                   |
| ZZ               | 6-7-22-23   | 4 - 3/8" x 2 1/2"  |                   |
| 23               | 6-7-22-23   | 4 - 3/8" x 2 1/2"  |                   |
| 14               | 3-5-15-17   | 4 - 3/8" x 2 1/2"  |                   |
| W1 - Narrow Base | 8-10-18-20  | 4 - 5/16" x 2 1/2" |                   |
| W1 - Wide Base   | 9-11-19-21  | 4 - 5/16" x 2 1/2" |                   |
| NS               | 8-10-18-20  | 4 - 5/16" x 2 1/2" |                   |
| 5                | 8-10-18-20  | 4 - 5/16" x 2 1/2" |                   |
| 6                | 8-10-18-20  | 4 - 5/16" x 2 1/2" |                   |
| 8                | 8-10-18-20  | 4 - 5/16" x 2 1/2" |                   |

\* All Horizontal Engines Require Special Mounting.

another free manual from www.searctrormanuals.com

|                                  | Page     |   | Page     |
|----------------------------------|----------|---|----------|
| AIR CLEANER                      |          | GOVERNOR                                |          |
| Felt Type                        | 27       | Controls, Remote                        | 34 to 40 |
| Moss Type                        | 27       | Mechanical Type                         | 32       |
| Oil Bath Type                    | 27       | Pneumatic Type                          | 33       |
| BEARINGS                         |          | Speed Settings                          | 11 to 41 |
| Ball                             | 64       | IGNITION CABLE                          | 18       |
| Cam Gear                         | 65       | LUBRICATION                             |          |
| Drive                            | 62       | Correct Lubrication                     | 4        |
| Horizontal Engine                | 62       | Oil Leak at Exhaust Valve Push Rod Hole | 75       |
| Main                             | 60       | Oil Leaks at Exhaust Push Rod Hole      | 75       |
| Main, Sizes                      | 61       | Oil Pump                                | 66-71    |
| Magneto                          | 61-62    | Oil System, Change, Models I-IBP-WI-WMI | 81       |
| Oil Retainer                     | 63-64    | Oil System, Change, Models WM-WMG W'MG- |          |
| Reaming                          | 62-64    | PCWM                                    | 86-81    |
| Reaming—Tools                    | 60       | Pumping Oil                             | 75       |
| BLOWER HOUSING                   |          | MAGNETOS                                |          |
| Removing                         | 16       | All Models, except 9-14-23              | 18 to 25 |
| BREAKER POINTS                   |          | Magnematic, Models 9-14-23              | 23 to 25 |
| Adjusting                        | 18 to 23 | Magnetizing                             | 21       |
| Gap                              | 16       | Warped Plates                           | 57-75    |
| Tension                          | 16       | MODEL, ENGINES (See Engine Models)      |          |
| BREATHERS                        |          | OIL SYSTEMS (See Lubrication)           |          |
| Cleaning                         | 79-80    | OIL RETAINER, Bearing (See Bearings)    |          |
| Inside Type                      | 80       | OIL RETURN VALVE                        | 79       |
| Outside Type                     | 79       | OVERHAUL & TUNE-UP PROCEDURE            |          |
| CAM GEAR                         |          | Disassembly                             | 6        |
| Bearings                         | 65       | Reassembly                              | 6        |
| Checking                         | 55       | Repairs                                 | 7        |
| Lobe, Rejection Size             | 54       | Tune-up Data                            | 10       |
| Removing                         | 55       | PINS, PISTON (See Piston)               |          |
| Replacing                        | 55-56    | PISTON                                  |          |
| AUTOMATIC CHOKE                  | 31       | Aligning Rod & Piston                   | 51       |
| CARBURETOR                       |          | Assembling Rings to Pistons             | 52       |
| Adjustment—Table 3               | 10       | Connecting Rod, Checking                | 51       |
| Gravity Feed                     | 28-29    | Connecting Rod & Pin Rejection Sizes    | 52       |
| Suction Feed                     | 30       | Piston, Checking                        | 51       |
| Throttle Controls                | 34 to 40 | Piston Pin, Checking                    | 52       |
| COMPRESSION                      | 41 to 49 | Piston & Rod in Cylinder, Installing    | 53       |
| CONDENSOR                        |          | Rings, Checking                         | 51       |
| Capacity                         | 16       | REMOTE CONTROLS                         | 34 to 40 |
| CONNECTING RODS (See Pistons)    |          | RINGS, PISTON (See Piston)              |          |
| CRANKCASE COVER                  |          | RODS, CONNECTING (See Piston)           |          |
| Worn Thrust Face                 | 75       | SPARK PLUG                              |          |
| CRANKSHAFT                       |          | Specifications—Table 3                  | 10       |
| Checking                         | 55-56    | Checking                                | 15-16    |
| End Play, Checking               | 56-57    | SPEED SETTINGS                          |          |
| End Play, Correcting             | 57       | Special Engine Type Nos—Table 4         | 11-12    |
| Rejection Sizes                  | 54       | Standard Engines—Table 5                | 14-15    |
| Removing                         | 54       | STARTERS                                |          |
| Replacing                        | 55-56    | Adjusting & Assembling                  | 72-74    |
| CYLINDERS                        |          | Repairing                               | 72-74    |
| Bore Dimensions, Standard        | 58       | Retrievable                             | 74       |
| Head                             | 41       | TAPPET CLEARANCE                        | 41       |
| Inspection                       | 58       | TOOLS                                   |          |
| Resizing                         | 58-59    | Major Repair Tools                      | 82 to 85 |
| Welding                          | 59       | Mounting Board, Instruction             | 86       |
| ENGINE MODELS                    |          | TUNE-UP & OVERHAUL PROCEDURE            |          |
| Basic and Special                | 5        | Disassembly                             | 6        |
| FLYWHEEL                         |          | Reassembly                              | 6        |
| Assembling & Disassembly         | 16-17-18 | Repairs                                 | 8        |
| Magnetizing                      | 26       | Tune-up Data—Table 3                    | 10       |
| Mounting Holes, Models H-Y       | 17       | VALVES                                  |          |
| Rusted, Removing                 | 76       | Clearance—Table 3                       | 10       |
| FUEL SUPPLY SYSTEM               | 27-28    | Removing                                | 41-44    |
| FUEL PUMP                        | 31-32    | Reseating                               | 44       |
| GASOLINE                         | 4        | Guide, Checking                         | 45       |
| GEAR REDUCTION ASSEMBLIES        | 76 to 78 | Guide, Counterbore Tools                | 45       |
| Assembling                       | 78       | Guide, Installing                       | 45       |
| Covers, Assembling               | 77       | Guide Numbers                           | 45       |
| Cover Bushings, Reaming          | 76       | Guide, Removing                         | 45       |
| Reduction Drive Shafts, End Play | 78       | Seats                                   | 45-48    |
| GENERATOR (Model W'MG)           | 79       | Springs, Removing & Replacing           | 41-42-44 |
|                                  |          | Stellite                                | 48       |
|                                  |          | Tappets                                 | 41 to 44 |
|                                  |          | Timing                                  | 48-49    |
|                                  |          | Tools for Installing                    | 48       |