

16 H.P.
TWIN
(RED)

Onan

Service and Parts Manual

BF Engine

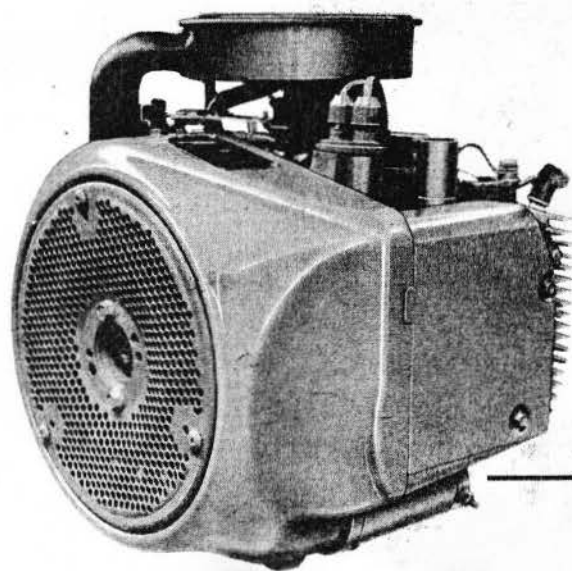

965-0250
12-87 (SPEC A-F)
Printed in U.S.A.

another free manual from www.searstractormanuals.com

Safety Precautions

It is recommended that you read your engine manual and become thoroughly acquainted with your equipment before you start the engine.

WARNING

This symbol is used throughout this manual to warn of possible serious personal injury.

CAUTION

This symbol refers to possible equipment damage.

Fuels, electrical equipment, batteries, exhaust gases and moving parts present potential hazards that could result in serious, personal injury. Take care in following these recommended procedures.

Safety Codes

- All local, state and federal codes should be consulted and complied with.
- This engine is not designed or intended for use in aircraft. Any such use is at the owner's sole risk.

General

- Provide appropriate fire extinguishers and install them in convenient locations. Use an extinguisher rated ABC by NFPA.
- Make sure that all fasteners on the engine are secure and accurately torqued. Keep guards in position over fans, driving belts, etc.
- If it is necessary to make adjustments while the engine is running, use extreme caution when close to hot exhausts, moving parts, etc.

Protect Against Moving Parts

- Do not wear loose clothing in the vicinity of moving parts, such as PTO shafts, flywheels, blowers, couplings, fans, belts, etc.
- Keep your hands away from moving parts.

Batteries

- Before starting work on the engine, disconnect batteries to prevent inadvertent starting of the engine.
- DO NOT SMOKE while servicing batteries. Lead acid batteries give off a highly explosive hydrogen gas which can be ignited by flame, electrical arcing or by smoking.
- Verify battery polarity before connecting battery cables. Connect negative cable last.

Fuel System

- DO NOT fill fuel tanks while engine is running.

- DO NOT smoke or use an open flame in the vicinity of the engine or fuel tank. Internal combustion engine fuels are highly flammable.
- Fuel lines must be of steel piping, adequately secured, and free from leaks. Piping at the engine should be approved flexible line. Do not use copper piping for flexible lines as copper will work harden and become brittle enough to break.
- Be sure all fuel supplies have a positive shutoff valve.

Exhaust System

- Exhaust products of any internal combustion engine are toxic and can cause injury, or death if inhaled. All engine applications, especially those within a confined area, should be equipped with an exhaust system to discharge gases to the outside atmosphere.
- Do not use exhaust gases to heat a compartment.
- Make sure that your exhaust system is free of leaks. Ensure that exhaust manifolds are secure and are not warped by bolts unevenly torqued.

Exhaust Gas is Deadly!

Exhaust gases contain carbon monoxide, a poisonous gas that might cause unconsciousness and death. It is an odorless and colorless gas formed during combustion of hydrocarbon fuels. Symptoms of carbon monoxide poisoning are:

- Dizziness
- Headache
- Weakness and Sleepiness
- Vomiting
- Muscular Twitching
- Throbbing in Temples

If you experience any of these symptoms, get out into fresh air immediately, shut down the unit and do not use until it has been inspected.

The best protection against carbon monoxide inhalation is proper installation and regular, frequent inspections of the complete exhaust system. If you notice a change in the sound or appearance of exhaust system, shut the unit down immediately and have it inspected and repaired at once by a competent mechanic.

Cooling System

- Coolants under pressure have a higher boiling point than water. DO NOT open a radiator pressure cap when coolant temperature is above 212°F (100°C) or while engine is running.

Keep the Unit and Surrounding Area Clean

- Make sure that oily rags are not left on or near the engine.
- Remove all unnecessary grease and oil from the unit. Accumulated grease and oil can cause overheating and subsequent engine damage and present a potential fire hazard.

SERVICE MANUAL

FOR

BF

GARDEN TRACTOR ENGINES

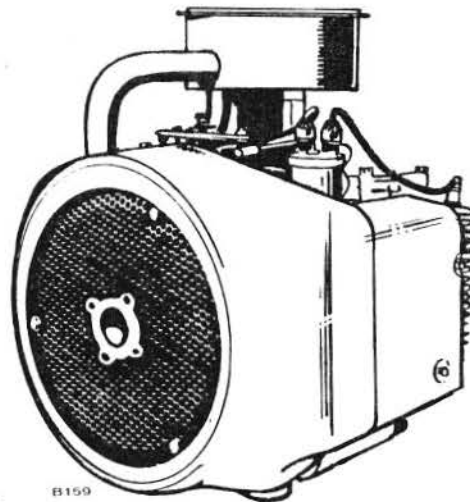

WE SUGGEST THIS BOOK BE KEPT HANDY FOR READY REFERENCE, EITHER FOR ORDERING PARTS OR MAKING ADJUSTMENTS.

TABLE OF CONTENTS

GENERAL INFORMATION	2
SPECIFICATIONS	3
DIMENSIONS AND CLEARANCES	4
ASSEMBLY TORQUES	4
ENGINE TROUBLE SHOOTING	5
OIL SYSTEM	6
FUEL SYSTEM	8
IGNITION AND BATTERY CHARGING	12
STARTING SYSTEM	15
ENGINE DISASSEMBLY	18
PARTS CATALOG	29
ENGINE WIRING DIAGRAM	47

another free manual from www.searstractormanuals.com

GENERAL INFORMATION

This manual contains proper information for the servicing and overhaul of your Onan engine. Use the parts catalog in the rear portion of this book to help you with disassembly and assembly procedures.

NOTE: *Flywheel end of engine is considered the front. Left and right sides are determined looking at front of engine.*

If it is necessary to contact your dealer or the factory about this engine, always supply the complete Model and Spec Number as well as the Serial Number shown on the engine nameplate. The engine nameplate is located on left side of blower housing (end opposite oil filter).

Refer to the *Troubleshooting Guide* for assistance in locating and correcting troubles which may occur. If a major repair or overhaul becomes necessary, the engine should be carefully checked and necessary repairs made by a competent mechanic. Maintain factory limits and clearances as shown, replacing worn parts when necessary.

ENGINE MODEL REFERENCE

Identify your model by referring to the MODEL and SPEC (specification) NO. as shown on the unit nameplate. Always use this number and the engine serial number when making reference to your engine.

How to interpret MODEL and SPEC NO.

BF - MS/0123 A

1	2	3	4

1. Factory code for general identification purposes.
2. Specific Type:
S - MANUAL STARTING
MS - ELECTRIC STARTING
3. Factory code for optional equipment supplied.
4. Specification (Spec Letter) advances with factory production modification.

WARNING

TO AVOID POSSIBLE PERSONAL INJURY OR EQUIPMENT DAMAGE, AN AUTHORIZED SERVICE REPRESENTATIVE MUST PERFORM ALL SERVICE.

SPECIFICATIONS

Engine Manufacturer	Onan
Engine Design	Four Cycle, Air-Cooled, Two Cylinder
Horsepower at 3600 rpm	16
Displacement	40.3 cu. in.
Bore	3-1/8 inch
Stroke	2-5/8 inch
Compression Ratio	7 to 1
Crankshaft	Horizontal, Ductile Iron
Valves	Mechanical, Poppet
Bearings (Main and Rod)	Sleeve
Oil Capacity	4 pints w/o filter
Battery Charging System	12 volt, 15 amp Flywheel Alternator

TUNE-UP SPECIFICATIONS

Tappets (Cold) Intake005
Exhaust013
Breaker Point Gap (Full Separation and Engine Cold)025 "
Spark Plug Gap025
Ignition Timing (Engine Not Running, Cold Setting)	* 25° BTC

* - Preferred setting.

DIMENSIONS AND CLEARANCES

All dimensions and clearances given at room temperature of 70°F.
All values in inches unless otherwise specified.

	Minimum	Maximum
CAMSHAFT AND CRANKSHAFT		
Crankshaft Main Bearing Journal to Bearing Clearance	0.0025	0.0038
*Crankshaft End Play	0.006	0.012
Camshaft Bearing to Camshaft	0.0015	0.0030
Camshaft End Play	0.003	
*Crankshaft Rod Journal to Rod Bearing	0.0020	0.0033
Connecting Rod End Play	0.002	0.016
Timing Gear Backlash	0.002	0.003
Oil Pump Gear Backlash	0.002	0.005
PISTON AND CYLINDER		
Piston Pin in Piston	0.0002	0.0004
Piston Pin in Rod	0.0002	0.0007
*Piston Ring Gap in Cylinder	0.010	0.020
Piston Clearance in Cylinder-Measured .10 Below Oil		
Control Ring, 90° from Pin	0.001	0.003
Cylinder Bore - Standard Size	3.1245	3.1255
Crankshaft Main Bearing Journal - Standard Size	1.9992	2.0000
Crankshaft Rod Bearing Journal - Standard Size	1.6252	1.6260
TAPPETS AND VALVES		
*Valve Seat Width	1/32	1/8
*Valve Face Angle		44°
*Valve Seat Angle		45°
Valve Stem to Guide - Intake	0.0010	0.0025
Valve Stem to Guide - Exhaust	0.0035	0.0040
Tappet to Cylinder Block Clearance	0.0015	0.0030
Tappet Adjustment (Cold)		
* Intake		0.005
* Exhaust		0.013

* - Frequently used overhaul values.

ASSEMBLY TORQUES AND SPECIAL TOOLS

BOLT TORQUE	FT.-LB.
Gearcase Cover	8 - 10
Cylinder Head Stud Nuts (Cold)	14 - 16
Rear Bearing Plate Screws	25 - 27
Starter Mounting Bolts	18 - 20
Connecting Rod Bolt	14 - 16
Flywheel Cap Screw	50 - 55
Other 5/16" Cylinder Block	
Stud and Nuts	8 - 10
Oil Base	18 - 23
Manifold Mounting Screws	6 - 10
Oil Pump	7 - 9

The following special tools are available from Onan, for further information see Tool Catalog 900-0019.

- Valve Seat Driver
- Valve Guide Driver
- Oil Guide and Driver
- Combination Bearing Remover (Main and Cam)
- Combination Bearing Driver (Main and Cam)
- Flywheel Puller

It is for
 Pe
 another free manual from www.seartractormanuals.com

ENGINE TROUBLESHOOTING

TROUBLE	Backfire at Carburetor	Bearing Wear	Black Exhaust	Blue Exhaust	Burned Valves	Connecting Rods	Crankshaft Wear	Cylinder Slowly	Engine Stops	Failure to Start	Governor Hunting	High Oil Pressure	Low Oil Pressure	Loss of Coolant (Water Cooled)	Mechanical Knocks	Misfiring	Overheating (Air Cooled)	Overheating (Water Cooled)	Piston Wear	Poor Compression	Ring Wear	Sticking Valves	CAUSE
																						STARTING SYSTEM	
																						Loose or Corroded Battery Connection	
																						Low or Discharged Battery	
																						Faulty Starter	
																						Faulty Start Solenoid	
																						IGNITION SYSTEM	
																						Ignition Timing Wrong	
																						Wrong Spark Plug Gap	
																						Worn Points or Improper Gap Setting	
																						Bad Ignition Coil or Condenser	
																						Faulty Spark Plug Wires	
																						FUEL SYSTEM	
																						Out of Fuel - Check	
																						Lean Fuel Mixture - Readjust	
																						Rich Fuel Mixture or Choke Stuck	
																						Engine Flooded	
																						Poor Quality Fuel	
																						Dirty Carburetor	
																						Dirty Air Cleaner	
																						Dirty Fuel Filter	
																						Defective Fuel Pump	
																						INTERNAL ENGINE	
																						Wrong Valve Clearance	
																						Broken Valve Spring	
																						Valve or Valve Seal Leaking	
																						Piston Rings Worn or Broken	
																						Wrong Bearing Clearance	
																						COOLING SYSTEM (AIR COOLED)	
																						Poor Air Circulation	
																						Dirty or Oily Cooling Fins	
																						Blown Head Gasket	
																						COOLING SYSTEM (WATER COOLED)	
																						Insufficient Coolant	
																						Faulty Thermostat	
																						Worn Water Pump or Pump Seal	
																						Water Passages Restricted	
																						Defective Gaskets	
																						Blown Head Gasket	
																						LUBRICATION SYSTEM	
																						Defective Oil Gauge	
																						Relief Valve Stuck	
																						Faulty Oil Pump	
																						Dirty Oil or Filter	
																						Oil Too Light or Diluted	
																						Oil Level Low	
																						Oil Too Heavy	
																						Dirty Crankcase Breather Valve	
																						THROTTLE AND GOVERNOR	
																						Linkage Out of Adjustment	
																						Linkage Worn or Disconnected	
																						Governor Spring Sensitivity Too Great	
																						Linkage Binding	

OIL SYSTEM

CRANKCASE OIL

Change crankcase oil every 50 operating hours and only when engine is warm. (Exception: Drain initial oil fill at 25 operating hours.)

To drain, remove the 1/2 inch pipe plug on the rear corner of the oil base. After oil drains, replace the pipe plug and refill crankcase with 4 pints (4-1/2 if equipped with filter) of a good quality detergent oil. Oil must meet or exceed the API (American Petroleum Institute) designation SE or SE/CC; this oil was formerly designated as MS, MS/DG or MS/DM (Figures 1 and 2).

For temperatures above 30°F, use SAE 30 oil; for temperatures below 30°F, use 5W30 or 10W.

In extremely dusty conditions or in very cold weather, change oil at least every 25 hours of operation.

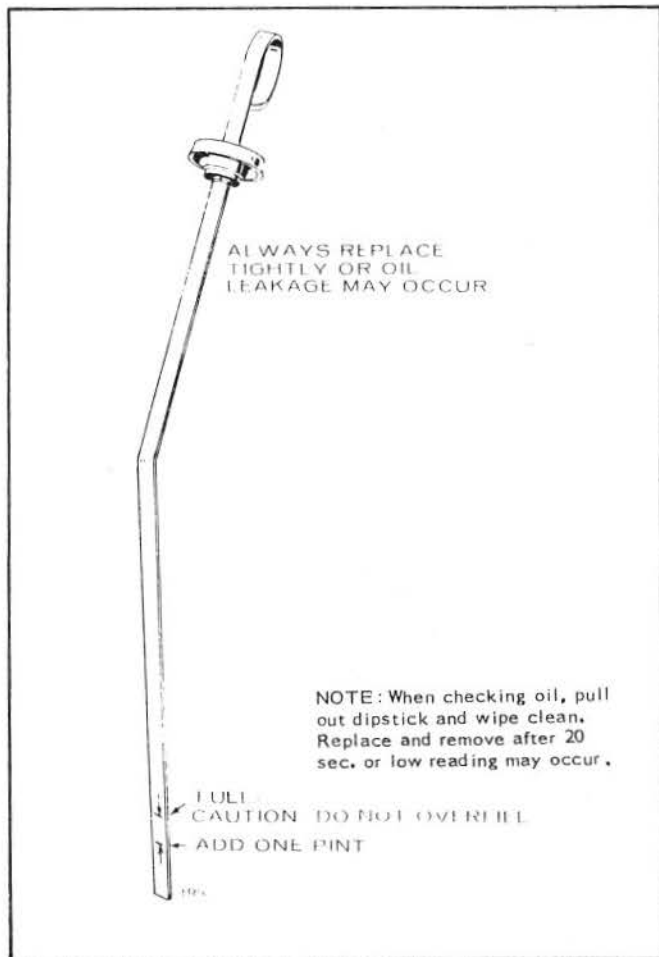

FIGURE 1. CRANKCASE OIL FILL

CAUTION Do not overfill crankcase. Do not use service DS oil. Do not mix brands or grades of motor oil. Engine damage could result from mixing non-compatible oils.

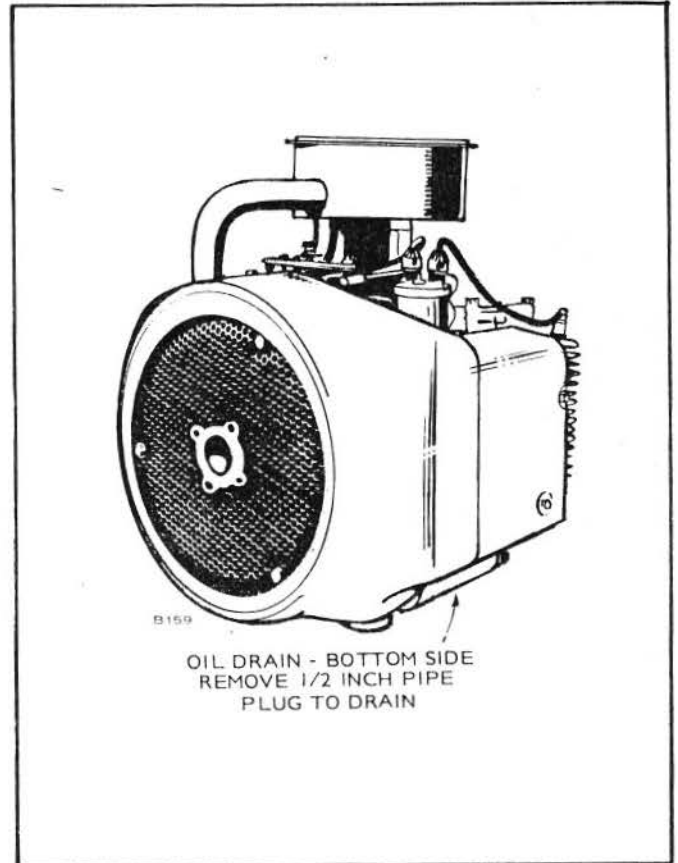

FIGURE 2. OIL DRAIN LOCATION

OIL FILTER (OPTIONAL)

Change the crankcase oil filter every 200 hours; change more frequently in extremely dusty conditions. Remove the filter by turning counterclockwise with a filter wrench. Before installing a new filter, coat the gasket on the filter base with a light film of new oil. Install by turning clockwise until a light friction is noted, then turn an additional 1/2 turn.

Crankcase Breather: This engine uses a crankcase breather valve for maintaining crankcase vacuum. No maintenance is generally required. If the crankcase becomes pressurized as evidenced by oil leaks at the seals, clean baffle and valve in a suitable solvent. See Figure 3.

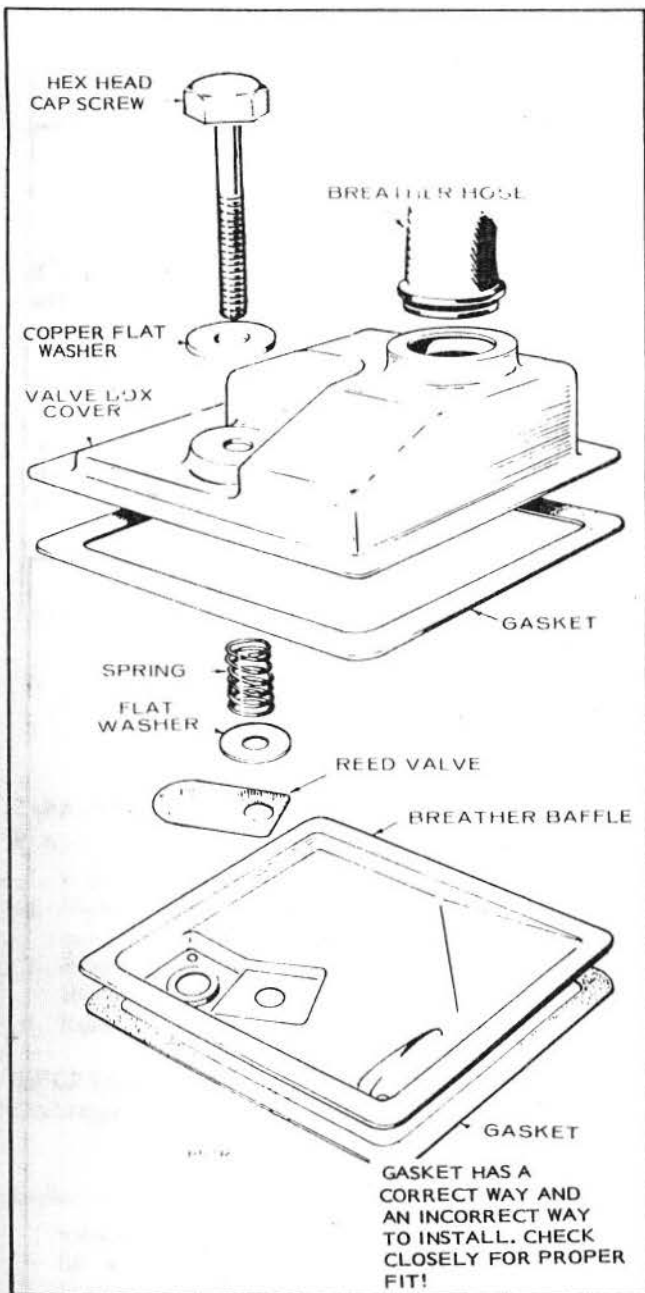

FIGURE 3. CRANKCASE BREATHER

PRESSURE LUBRICATION

Pressure lubricated engines use an oil pump to lubricate engine parts. If oil pressure is low, the pump should be checked.

To remove the oil pump, it is necessary to detach the intake cup assembly, as illustrated in Figure 4.

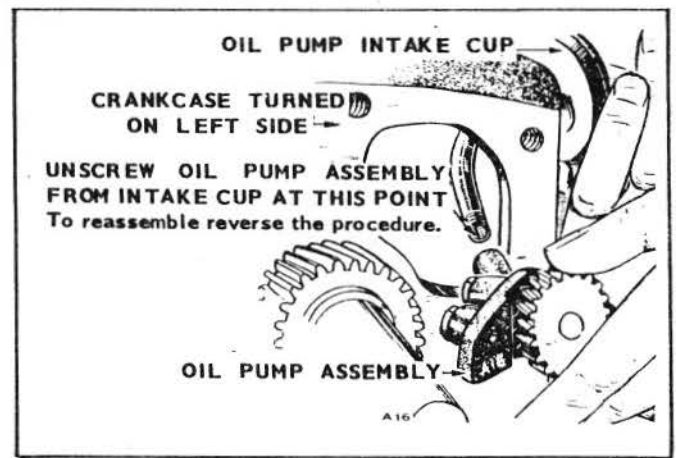

FIGURE 4. OIL PUMP ASSEMBLY

Check the oil pump thoroughly for worn parts. Oil the pump to prime it before reinstalling. Except for gaskets and suction cup, the component parts of the pump are not available individually. Install a new pump assembly if required.

If new oil pump gaskets are installed, they should be the same thickness as those removed. A gasket kit with various thickness gaskets is available.

OIL BY-PASS VALVE

The by-pass valve (located to the right and behind gear cover), controls oil pressure by allowing excess oil to flow directly back to the crankcase. Normally the valve begins to open about 30 psi.

The valve is non-adjustable and normally does not need maintenance. To determine if valve is not working correctly, caused by a sticky plunger, inspect as follows:

1. Remove 3/8 x 24 x 1 cap screw located behind gear cover and under governor arm.
2. Remove spring and plunger with a magnet tool. Clean plunger and spring with a suitable solvent and reinstall.

FUEL SYSTEM

CARBURETOR CLEANING AND INSPECTION

To clean the carburetor, soak all components thoroughly in a good carburetor cleaner, following the manufacturer's instructions. Be sure to remove all carbon from carburetor bore, especially in the area of the throttle valve. After soaking, clean out all passages with filtered, compressed air.

Check the adjusting needles and nozzle for damage. If float is loaded with fuel or damaged, replace it. The float should fit freely on its pin without binding.

Check the choke and throttle shafts for excessive side play and replace if necessary.

Note: Carburetor repair and gasket kits are available from your nearest Onan Parts Center.

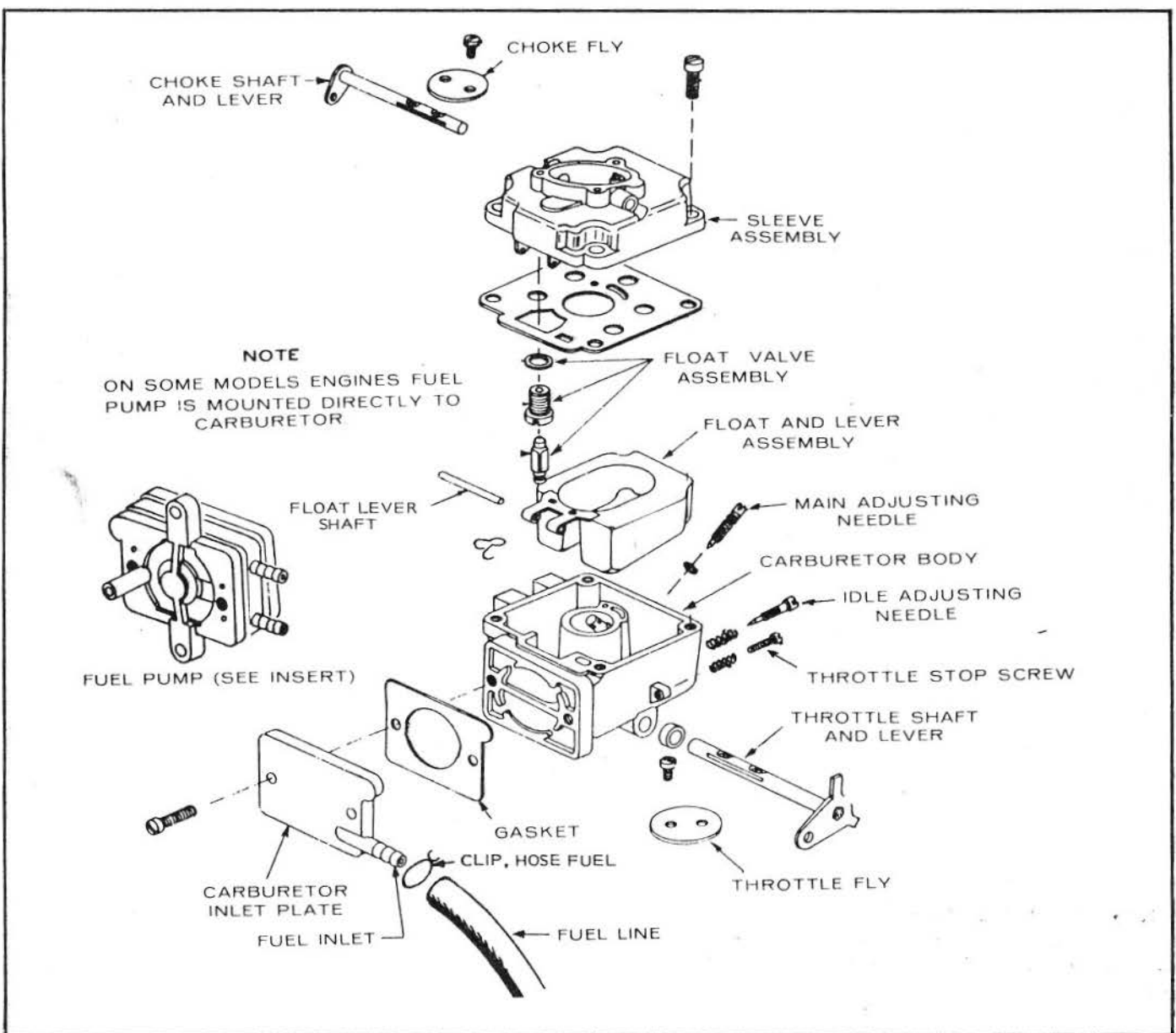

FIGURE 5. EXPLODED VIEW OF CARBURETOR

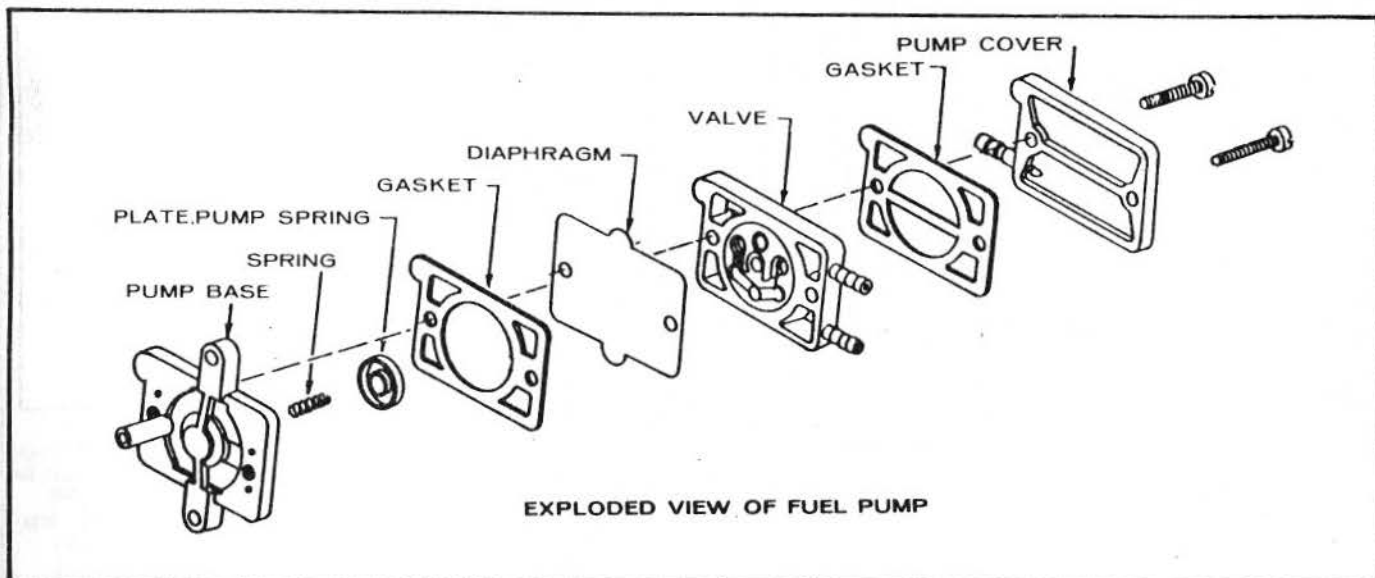

FIGURE 5A. EXPLODED VIEW OF FUEL PUMP

CARBURETOR DISASSEMBLY AND REPAIR (Figure 5)

Removal:

1. Remove air cleaner and hose.
2. Disconnect governor and throttle linkage, choke control and fuel line from carburetor.
3. Remove the four intake manifold capscrews and lift complete manifold assembly from engine.
4. Remove carburetor from intake manifold.

IMPORTANT: Always work on carburetor in clean conditions.

Replacing Needle and Valve Seat:

1. Remove four screws from top of carburetor and lift off float assembly.
2. Invert float assembly as shown in Figure 6.
3. Push out pin that holds float to cover.
4. Remove float and set aside in a clean place. Pull out needle and spring.
5. Remove valve seat and replace with a new one, making sure to use a new gasket.
6. Install new bowl gasket.
7. Clip new needle to float assembly with spring clip. Install float.

Carburetor Float Adjustment:

1. Invert float assembly and casting.
2. With the float resting lightly against the needle and seat, there should be $1/8$ " clearance between the bowl cover gasket and the free end of the float.
3. If it is necessary to reset the float level, bend the float tangs near the pin to obtain a $1/8$ " clearance (Figure 6).

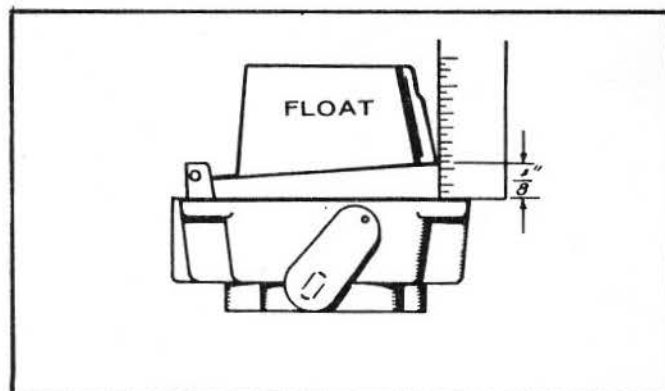

FIGURE 6. FLOAT ADJUSTMENT

Fuel Pump Disassembly (Figure 5A):

1. Remove vacuum line and fuel line.
2. Remove the two fuel pump attaching screws.
3. Grasp pump and carefully pull apart. Diaphragm, plunger, return spring, pump body and mounting gaskets will now be loose.
4. Internal fuel pump parts are available in a repair kit. Check Parts Catalog for correct part number.
5. Ensure that clamps are replaced on fuel line.

CAUTION Use care when reassembling pump; all parts must be perfectly aligned, or pump will leak, creating a fire hazard.

CARBURETOR ADJUSTMENTS

The carburetor has a main fuel valve adjusting screw and an idle valve adjusting screw (Figure 7). A low speed adjustment screw is shown in Figure 8.

Initial Adjustment:

1. Turn main fuel valve clockwise until it just closes.

CAUTION

Do not open main fuel jet more than 1/2 turn beyond the maximum power point as this could cause spark plug fouling etc.

2. Now open main fuel valve 2 turns counterclockwise.
3. Close idle valve in same manner and open it one turn (counterclockwise).
4. This initial adjustment will permit engine to start and warm up prior to final adjustment.

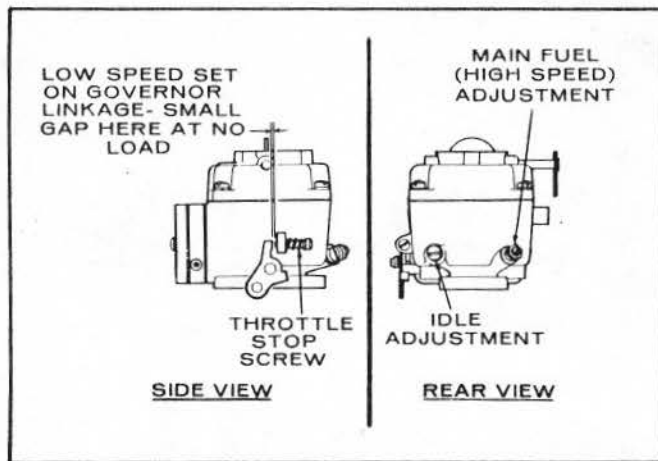

FIGURE 7. MAIN FUEL AND IDLE VALVE ADJUSTMENT

Final Adjustment:

1. Turn main fuel valve in until engine misses (lean mixture), then turn it out past the point where engine runs smoothly until engine runs unevenly (rich mixture). Turn valve to mid-point between lean and rich so engine runs smoothly.
2. Hold engine at idle position and set low speed adjustment screw (Figure 8) until a fast idle is obtained (1200 rpm).
3. Hold throttle in idle position and turn idle adjustment valve in (lean) and out (rich) until engine idles smoothly.
4. Reset low speed adjustment screw so engine idles at 1200 rpm.
5. Release throttle - engine should accelerate without hesitation. If engine does not accelerate properly, readjust main fuel valve by turning out slightly.

Important: Do not open more than 1/2 turn beyond maximum power point.

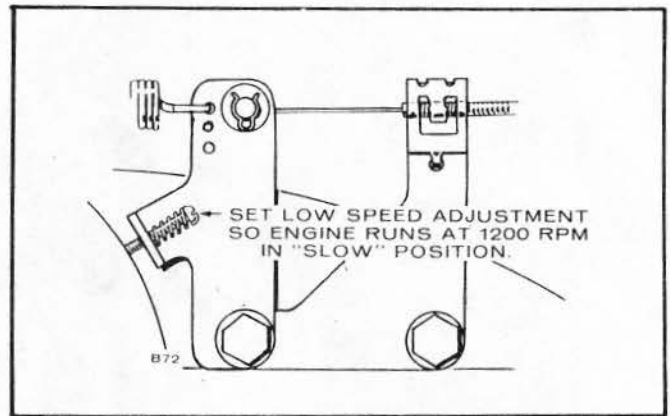

FIGURE 8. LOW SPEED ADJUSTMENT

GOVERNOR (Figure 9)

These engines are adapted for use where a wide range of speed settings is desired. Engine speed is controlled at any given point between minimum and maximum by simply shifting the throttle lever on the dash panel until the desired speed is reached.

The design of the variable speed governor gives an automatic decrease in sensitivity when the speed is increased and the result is good stability at all speeds.

A reliable instrument for checking engine speed is required for accurate governor adjustment. Engine speed can be checked with a tachometer.

Check the governor arm, linkage, throttle shaft, and lever for binding condition or excessive slack and wear at connecting points. A binding condition at any point will cause the governor to act slowly and regulation will be poor. Excessive looseness can cause a hunting condition and regulation will be erratic. Work the arm back and forth several times by hand while the engine is idling to check for above conditions.

If governor is hunting or not operating properly, adjust as follows and as shown in Figure 9.

1. Disconnect linkage (A) from one of holes (C).
2. Push linkage (A) and governor arm (B) as far back (toward carburetor) as they will go.
3. Holding linkage and governor arm toward direction of carburetor, insert end of linkage into whichever hole (C) (in governor arm) lines up the closest.

The governor control spring is factory set in the top or second hole of the governor arm (farthest from pivot). To increase the sensitivity, move the spring loop into the hole nearest the pivot point or shaft. To decrease the sensitivity, move the spring outward. After the sensitivity has been set, adjust the low speed with the adjustment screw on the control wire bracket.

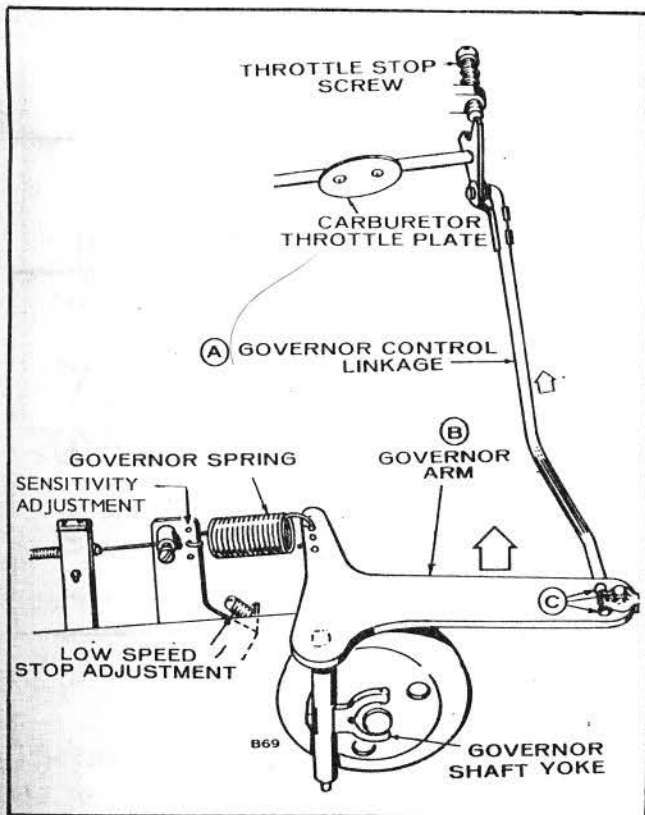

FIGURE 9. GOVERNOR ADJUSTMENTS

AIR CLEANER

CAUTION If air cleaner becomes too dirty, engine will not receive sufficient air to run properly. Symptoms: Loss of power, flooding, hard to start and overheating.

Engine is equipped with a paper element. If the engine is equipped with polyurethane pre-cleaner, it must be removed, cleaned and oiled every 25 hours of operation, or more under extremely dusty conditions.

1. To clean pre-cleaner wash in water and detergent referring to Figure 10. Remove excess water by squeezing like a sponge and allow to dry thoroughly. Distribute three tablespoons of SAE 30 engine oil evenly around the pre-cleaner. Knead into and wring excess oil from pre-cleaner.
2. Depending on conditions in which the tractor is operating, the inner paper element should be replaced whenever it becomes excessively dirty or oily.

CAUTION Never run the engine with the air cleaner removed. Dirt will enter the engine and wear out the rings causing excessive blow-by.

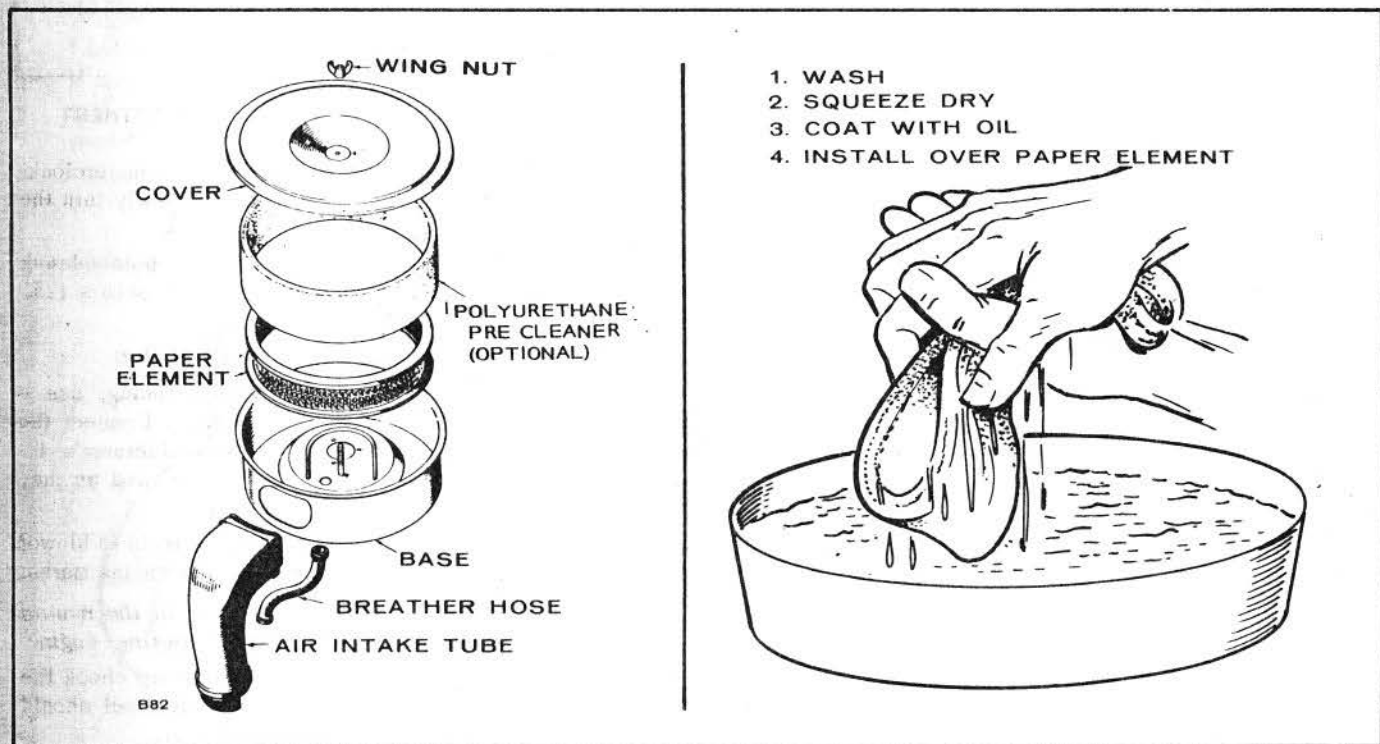

FIGURE 10. AIR CLEANER ASSEMBLY

IGNITION AND BATTERY CHARGING

BREAKER POINTS

To maintain maximum efficiency from the engine, change the breaker points every 200 hours of operation. Proceed as follows when engine is cold:

1. Remove the two screws and the cover on the breaker box.
2. Remove the two spark plugs so engine can be easily rotated by hand. Check condition of spark plugs at this time.
3. Refer to Figure 11. Remove mounting nut (A) and pull the points out of the box just far enough so screw (B) can be removed and leads disconnected.
4. Remove screw (C) and replace condenser with a new one.
5. Replace points with a new set but do not completely tighten mounting nut (A).
6. Remove the air intake hose that connects to blower housing. This provides an access to view timing mark.
7. Rotate the engine clockwise (facing flywheel) by hand until the 25° BTC mark on gear cover aligns with mark on flywheel. Turn another 1/4 turn (90°) to ensure points are fully open.
8. Using a screwdriver inserted in notch (D) on the right side of points, turn points until gap measures .023 to .025" with a flat thickness gauge. (Be sure feeler is clean.) Tighten mounting nut and recheck gap.
9. Check ignition time as soon as possible using continuity test lamp.

IGNITION TIMING

The timing on the engine is preset at the factory. A non-movable breaker point box is used, however a slight timing change could be made by adjusting points.

The engine is equipped with an automotive type battery ignition system. Both spark plugs fire simultaneously, thus the need for a distributor is eliminated. Spark advance is set at 25° BTC (before top center) and should be maintained for best engine performance. Always check timing after replacing ignition points or if noticing poor engine performance. Proceed as follows:

Timing Procedure (Preferred Method) – Engine Not Running and Cold:

1. Connect a continuity test lamp set across the ignition breaker points. Touch one test prod to the breaker box terminal to which the coil lead is connected and touch the other test prod to a good ground on the engine.

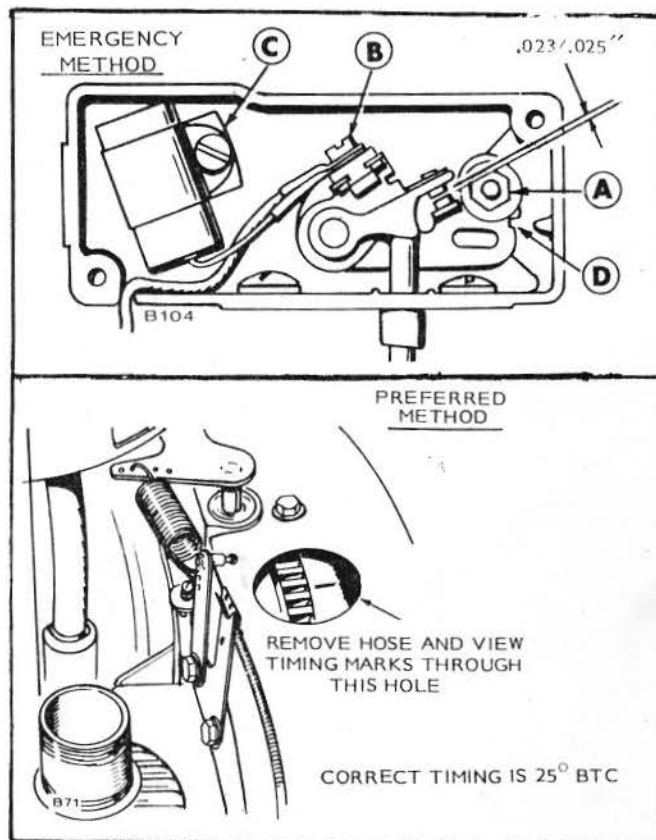

FIGURE 11. IGNITION AND TIMING ADJUSTMENT

2. Turn crankshaft against rotation (counterclockwise) until the points close. Then slowly turn the crankshaft with rotation (clockwise).
3. The lamp should go out just as the points break which is the time at which ignition occurs (25° BTC).

Timing Procedure – Engine Running and Hot:

1. To accurately check the ignition timing, use a timing light when engine is running. Connect the timing light according to its manufacturer's instructions. Either spark plug can be used as they fire simultaneously.
 2. Remove the air intake hose that connects to blower housing to provide an access to view timing marks.
- WARNING** Be sure tractor is in the neutral position before starting engine.
3. Start the engine. When engine warms up check the ignition timing. The mark on the flywheel should line up with the 25° mark on the cover.
 4. Replace hose, breaker box cover and any other hardware removed from engine.

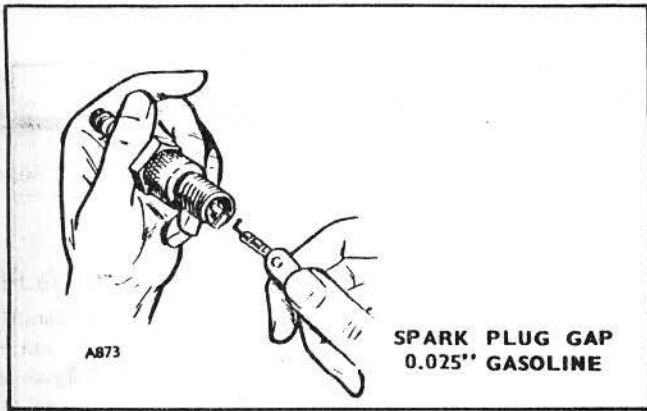

FIGURE 12. SPARK PLUG GAP

SPARK PLUGS (Figure 12)

Remove both spark plugs and install new ones every 100 hours. Use ONAN No. 167-0241 or Champion H-8. Check to be sure spark plug gap is set at .025 " .

IGNITION COIL

To test primary and secondary windings within the ignition coil proceed as follows:

1. Use a Simpson 260 VOM or equivalent.
2. Place back lead on ground (-) terminal of coil and red lead to positive (+) terminal. Primary resistance should read 3.87 - 4.73 ohms.
3. Change resistance setting on ohmmeter. Place ohmmeter leads inside of spark plug cable holes (Figure 13). Secondary resistance should read 12,600 - 15,400 ohms.
4. If any of the above conditions are not met, replace coil. Refer to *Parts Catalog* for correct part number.

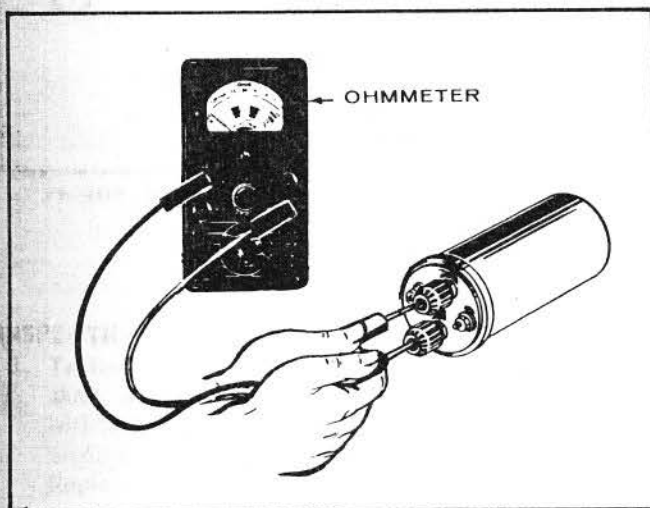

FIGURE 13. COIL TEST

CAUTION This engine uses a 12 volt, negative ground system. Alternator must be connected to battery at all times when engine is running. Do not reverse battery cables. Damage to regulator or ignition coil could result if cables are reversed.

Battery Inspection: Check battery cells with a hydrometer. The specific gravity reading should be approximately 1.280 at 80°F. (Figure 14).

If cells are low on water, add distilled water and recharge. If one cell is low, check case for leaks. Keep the battery case clean and dry. An accumulation of moisture will lead to a more rapid discharge and battery failure.

Keep the battery terminals clean and tight. After making connections, coat the terminals with a light application of petroleum jelly or non-conductive grease to retard corrosion.

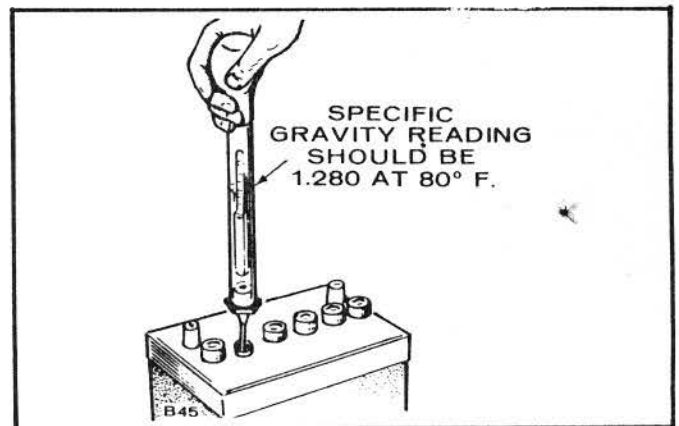

FIGURE 14. SPECIFIC GRAVITY TEST

FLYWHEEL ALTERNATOR (Figure 15)

This unit is equipped with a permanent magnet flywheel alternator and solid-state voltage regulator-rectifier (output control). As with all solid-state electrical units, precautions are necessary when servicing. Observe the following.

Precautions:

1. Do not connect battery cables in the wrong polarity.
2. Do not short together alternator stator leads.
3. Do not run without a battery. Damage will occur to regulator and battery ignition coil.

Preservice Checks:

1. Check for a good ground between equipment and regulator-rectifier case.
2. Be sure output control plug (connector) is properly inserted into stator receptacle. This means the plug must push in and solidly bottom in the receptacle to eliminate any resistance due to a poor connection. Keep it clean and tight.
3. Check battery and its connection to be sure it is serviceable.

NOTE: Charging system tests require a fully charged battery for accuracy in isolating component malfunctions.

TESTING BATTERY CHARGING SYSTEM

Type of Failure	Test	Results
No charge to battery.	<ol style="list-style-type: none"> 1. With battery connected, check B+ to Ground voltage with DC voltmeter. If voltmeter reads 13.8 volts or higher, place load (headlights) on battery to reduce battery voltage to below 13.6 volts. Observe ammeter. <ol style="list-style-type: none"> a. If charge rate increases. b. If charge rate does not increase. 2. Disconnect plug from regulator-rectifier and test AC voltage at plug (two white wires, reading back into alternator). Voltage reads much less than 28 volts AC. 	<p>System okay. Battery was charged fully.</p> <p>Check for defective stator or regulator.</p> <p>Defective Stator or magnet group.</p>
Battery always charging at high rate.	<ol style="list-style-type: none"> 1. Check B+ to Ground voltage with DC voltmeter. <ol style="list-style-type: none"> a. If over 14.7 volts DC b. If under 14.7 volts DC 	<p>Regulator not functioning.</p> <p>Alternator system okay. Check battery charge - may be low.</p>

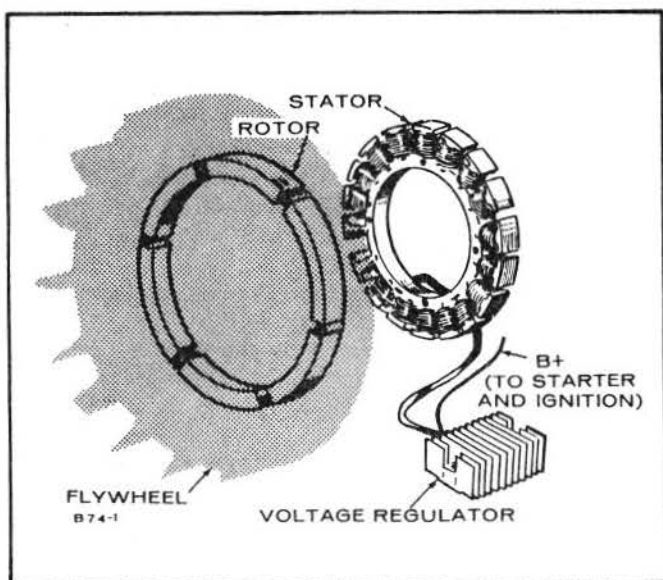

FIGURE 15. FLYWHEEL ALTERNATOR SYSTEM

another free manual from www.searstractormanuals.com

STARTING SYSTEM

ELECTRIC STARTER (Spec A & Spec B)

Normally the starter will require little or no service other than possible brush replacement. However, if through accident or misuse, the starter requires service or overhaul, the following information will provide the information necessary to perform this service.

STARTER DISASSEMBLY (Figure 16, Spec A; Figure 16A, Spec B)

1. Remove the through-bolts and separate the end cap, the housing and the armature.
2. Disassemble the drive assembly and the drive end cap by loosening the self-locking nut.

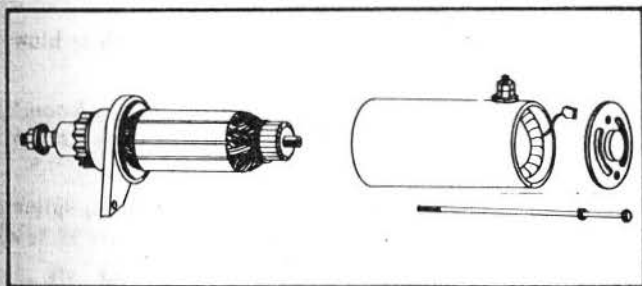

FIGURE 16. STARTER DISASSEMBLY (SPEC. A)

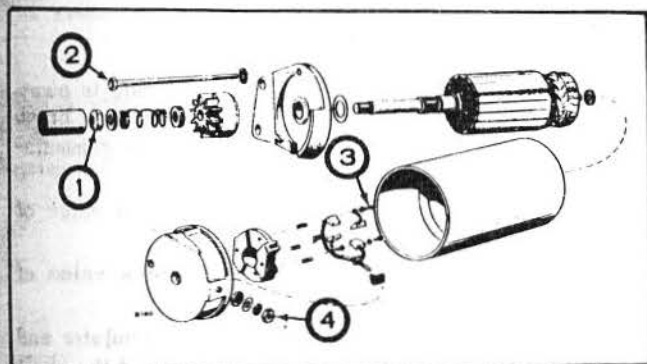

FIGURE 16A. STARTER DISASSEMBLY (SPEC. B)

INSPECTION OF PARTS (Spec A & Spec B)

1. **Testing Armature for Grounds:** Touch armature shaft or core and the end of each commutator bar with a pair of ohmmeter leads. If the ohmmeter reading is low, it indicates a grounded armature. Replace grounded armature. See Figure 17.

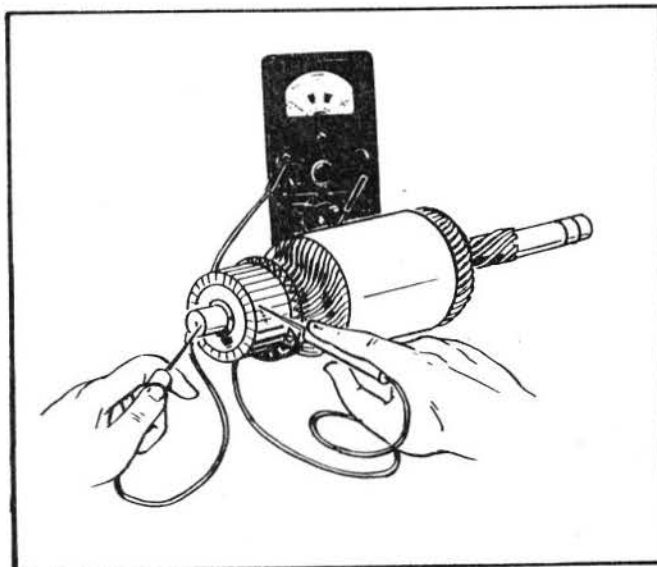

FIGURE 17. TESTING ARMATURE FOR GROUNDS

2. **Testing Armature for a Short Circuit:** Use a growler for locating shorts in the armature. Place armature in growler and hold a thin steel blade (e.g. hacksaw blade) parallel to the core and just above it while slowly rotating armature in growler. A shorted armature will cause the blade to vibrate and be attracted to the core. If armature is shorted, replace with a new one (Figure 18).
3. **Inspecting For An Open Circuit in Armature:** The most likely place to check for an open circuit is at the commutator riser bars. Inspect for loose connections on the points where the conductors are joined to the commutator bars (Spec A only).

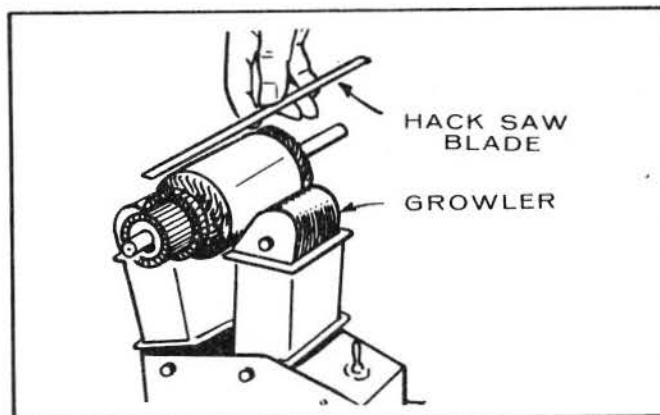

FIGURE 18. TESTING ARMATURE FOR SHORT CIRCUITS

4. Testing Field Coils for Open Circuit (Spec A Only)

Place one lead on the connector and the other on a clean spot on the brushholder. If the ohmmeter reading is high, the field coil is open. Check the other three brushholders in the same manner. See Figure 19.

5. Testing Field Coils for Grounds: (Spec A Only)

Place one lead on the connector and the other on a clean spot on the frame after unsoldering shunt field coil wire. If the ohmmeter reading is low, the fields are grounded, either at the connector or in the windings.

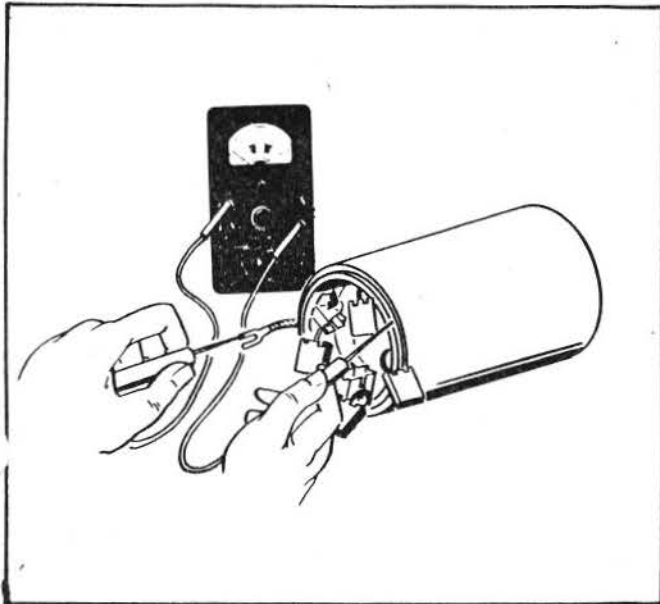

FIGURE 19. TESTING FIELD COILS FOR OPENS

6. Brush Inspection: If brushes are worn shorter than 1/4 inch, replace them. Check to see that brushes move smoothly in the brush holders. See Figure 20.

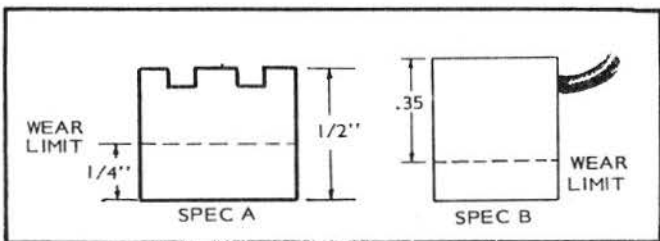

FIGURE 20. BRUSH WEAR LIMIT

7. Brush Spring Inspection (Spec A only): Check brush spring tension as shown in Figure 21. If spring tension reads 17 to 25 ounces, the spring is satisfactory.

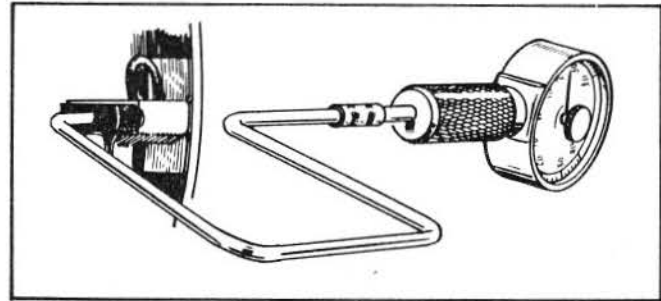

FIGURE 21. TESTING BRUSH SPRING TENSION

STARTER ASSEMBLY

Reassembly is the reverse of disassembly. When re-assembling, observe the following:

1. Wipe off any dirty parts with a clean cloth or blow clean using filtered compressed air.

NOTE: Bearings must not be immersed in cleaning fluid. These parts should be cleaned with a brush dipped in clean engine oil.

2. Apply SAE 10W-30 oil on the armature shaft, spline and bearings.

REASSEMBLY (Spec B only)

1. Assemble brushes so that chamfered side is away from the brush springs and position the brush shunts so that they will not contact the commutator or commutator end cap.
2. Torque bolts (Figure 16(a), item 3) to a value of 3-3-1/2 ft-lbs.
3. Torque nut (Figure 16(a), item 4) to a value of 4-5 ft-lbs.
4. Apply a thin film of grease to the commutator end of the armature shaft and to the portion of the shaft that contacts the bearings. Apply a generous film of Lubriplate "Aero" grease to the shaft thread.
5. Torque stop nut (Figure 16(a), item 1) to a value of 20-25 ft-lbs. Hold armature in a vise.
6. Torque thru-bolts (Figure 16(a), item 2) to a value of 4-1/2-6 ft-lbs.

CAUTION

Do not exceed the rated voltage of the motor (12-VDC). Excessive voltage could demagnetize the motor permanent magnet field.

another free manual from www.seastractormanuals.com

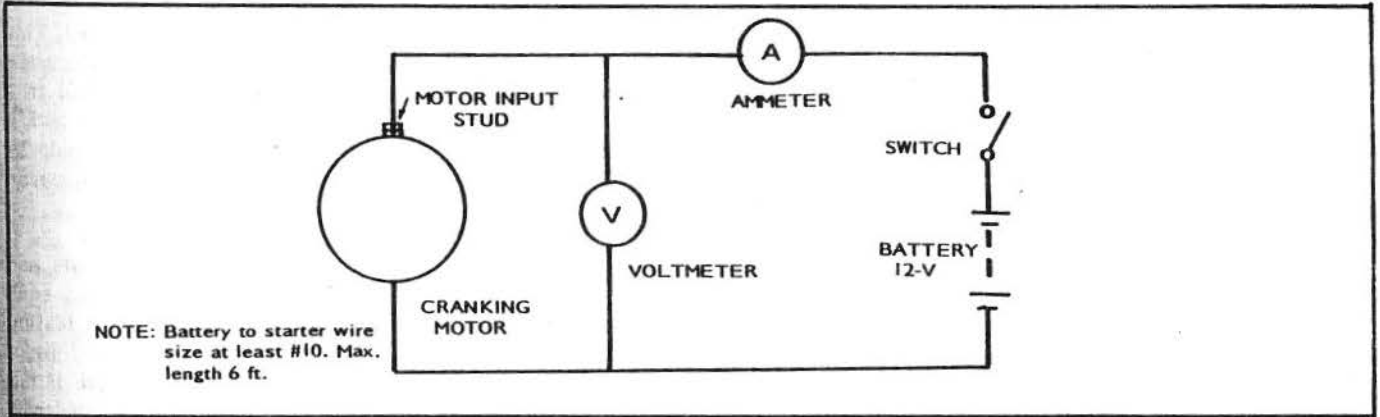

FIGURE 22. NO LOAD TEST

INSPECTING REASSEMBLED STARTER

1. **No Load Test:** Connect the starting motor as shown in Figure 22.

The values for this test are as follows:

	Spec A	Spec B
Battery Voltage	11.5 volts	12.0 volts
RPM	8000 rpm (min)	4,800-6,100
Maximum Current Draw . . .	25 amperes	32 amperes

- NOTE:**
1. To ensure good electrical contact, make sure starter to engine mounting surfaces are free of dirt or oil.
 2. When tightening attaching bolts and nut, starter gear should be held into ring gear to assure proper backlash.
 3. Battery to starting motor wire must be tightened securely.

CAUTION Starter motors are not designed for continuous operation. Do not operate more than 30 seconds per "ON" cycle. Do not operate starter more than 10 seconds in a stall condition if engine will not rotate. Serious damage could result if these time limits are exceeded.

ENGINE DISASSEMBLY

VALVE SYSTEM

Properly seated valves are essential to good engine performance. The aluminum cylinder heads are removable for valve servicing. Do not use a pry to loosen the cylinder head; rap sharply on the edge with a soft faced hammer, taking care not to break any cooling fins. A conventional type valve spring lifter may be used when removing the valve spring locks, which are of the split type. Clean all carbon deposits from the cylinder heads, piston tops, valves, guides, etc. If a valve face is burned or warped, or the stem worn, install a new valve. Refer to Figure 23.

Worn valve stem guides may be replaced from inside the valve chamber. Valve locks are split, tapered type, the smaller diameter of which must face toward the valve head. Tappets are also replaceable from the valve chamber, after first removing the valve assemblies.

The valve face angle is 44° . The valve seat angle is 45° . This 1° interference angle results in a sharp seating surface between the valve and the top of the valve seat. The interference angle method of grinding valves minimizes face deposits and lengthens valve life.

The valves should not be hand lapped, if at all avoid-

able, because the sharp contact may be destroyed. This is especially important where stellite faced valves and seats are used. Valve faces should be finished in a machine to 44° . Valve seats should be ground with a 45° stone and the width of the seat band should be $1/32''$ to $3/64''$ wide. Grind only enough to assure proper seating.

Remove all grinding compound from engine parts and place each valve in its proper location. Check each valve for a tight seat, using an air pressure testing tool. If such a tool is not available, make pencil marks at intervals across the valve face and observe if the marks rub off uniformly when the valve is rotated part of a turn against the seat.

Lightly oil the valve stems and assemble all parts removed.

The positive type valve rotators prolong valve life and decrease valve repairs. When functioning properly, the valve is rotated a fraction of a turn each time it opens. While at open position, the valve must rotate freely, but in only one direction. If rotators are faulty, install new rotators.

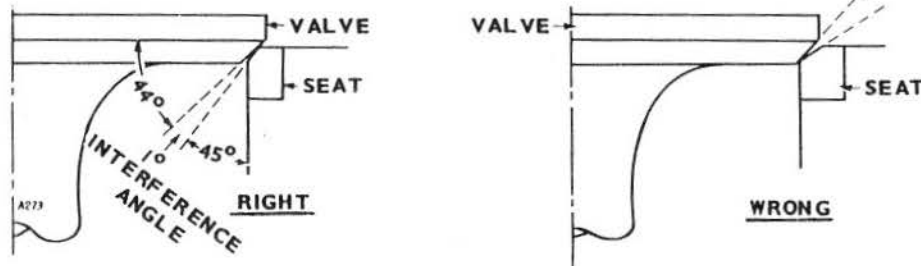

NOTE - USE A STANDARD AUTOMOTIVE TYPE WRENCH TO ADJUST THE TAPPETS.

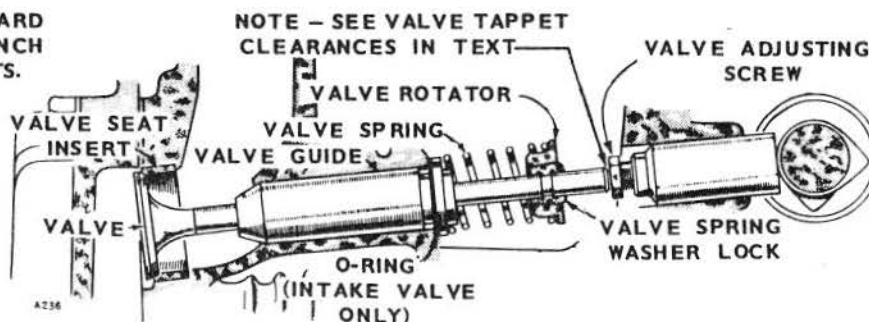

FIGURE 23. VALVE SYSTEM

Tapp
justa
shoul
shoul
every
ance
engin

1. F
2. R
3. R
4. U
5. F
6. F
7. T
8. T
9. R

Tappet Adjustment: The engine is equipped with adjustable valve tappets. The valve tappet clearance should be checked and adjusted, if necessary, at least every 200 operating hours or when poor engine performance is noticed. Adjust the valve clearance only when engine is at ambient temperature. Proceed as follows:

1. Remove ignition key to prevent accidental starting.
2. Remove all parts necessary to gain access to valve tappets.
3. Remove spark plugs to ease the task of turning the engine over by hand.
4. Use the engine flywheel to turn the engine over slowly by hand until the left hand intake valve opens and closes. Continue turning the flywheel until the TC mark is on the top and lined up with the TC mark on the gear cover. Both valves should be closed. This should place the left hand piston at the top of its compression stroke, the position it must be in to get proper valve adjustment for the left cylinder.
5. For the intake valve, a .007" thickness gauge should pass freely between valve stem and tappet, a thicker .009" gauge should not. (Figure 24)
6. For the exhaust valve, a .012" thickness gauge should pass freely between the valve stem and the tappet, a thicker .014" gauge should not.
7. To correct the valve clearance, use a 7/16" open end wrench to turn the adjusting screw to obtain the correct clearance. The screw is self-locking and will stay where it is set. A 9/16" open end wrench is required to hold the tappet while turning the adjusting screw.
8. To adjust valves on the right hand cylinder, turn engine one complete revolution and again line up mark on the flywheel and the TC mark on the gear cover. Then follow adjustment procedure given for left hand cylinder.
9. Replace all parts removed in Step 2. Tighten all screws securely. Torque manifold bolts to specified torque.

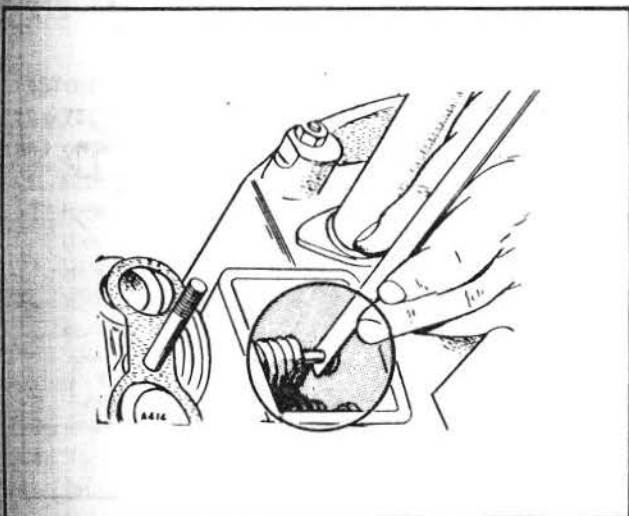

FIGURE 24. VALVE CLEARANCE

FLYWHEEL

Removing the flywheel is a relatively simple process, but the following procedure must be followed to avoid damage to the gear case and possible injury to the operator.

1. Turn the flywheel mounting screw outward about two turns.

WARNING Do not remove the screw completely since it acts as a restrainer when the flywheel snaps loose. If the flywheel is not held by the screw, the spring action in the wheel will cause it to fly off with great force which can cause injury to the operator.

2. Install a puller bar on the flywheel as shown in Figure 25.
3. Turn the puller bar bolts in, alternately, until the wheel snaps loose on the shaft.

CAUTION Do not use a screwdriver or similar tool or pry behind the flywheel against the gear case. The gear case cover is die-cast material and will break if undue pressure is applied in this manner.

4. Unscrew the puller from the flywheel, remove the flywheel mounting screw and washer and pull the flywheel off the shaft. Take care not to drop the wheel. A bent or broken fin will destroy the balance. Always use a steel key for mounting the flywheel.

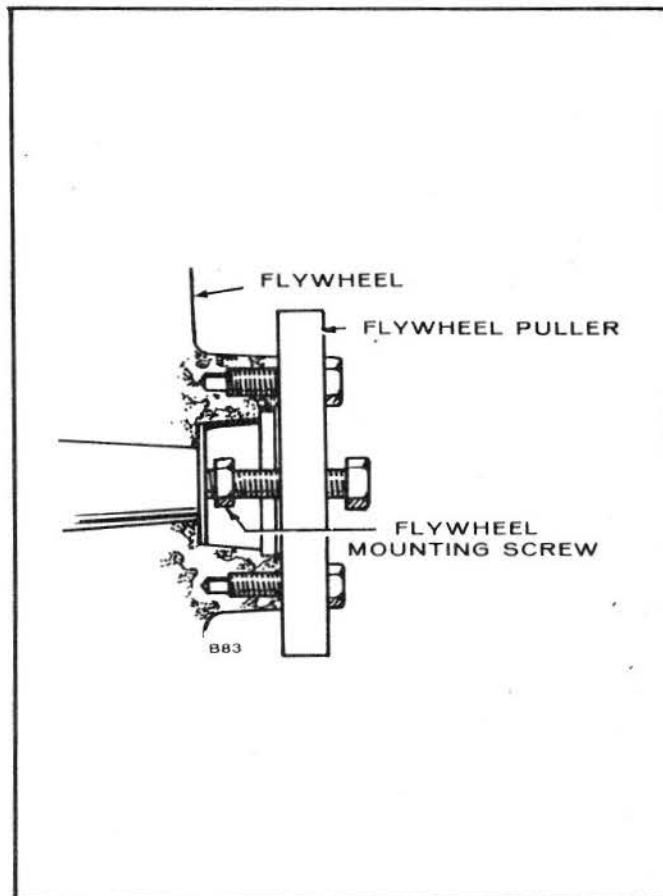

FIGURE 25. BLOWER WHEEL PULLEY

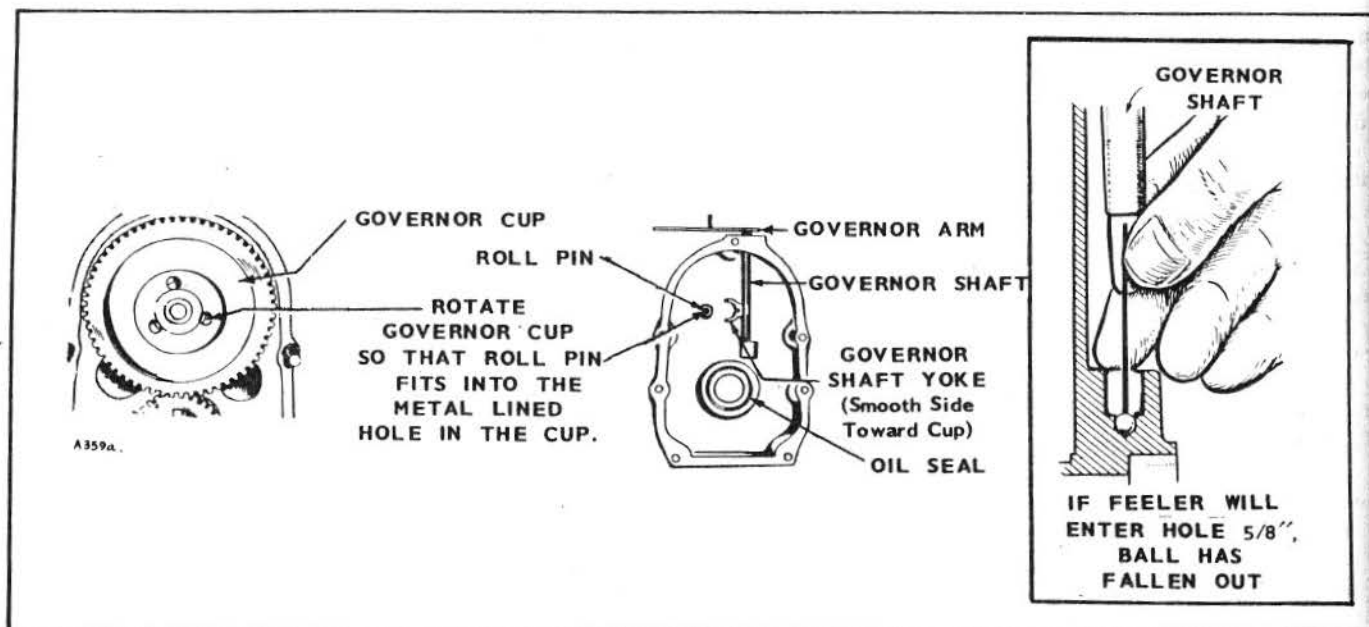

FIGURE 26. GEAR COVER ASSEMBLY

GEAR COVER (Figure 26)

After removing the mounting screws, tap the gear cover gently with a soft faced hammer to loosen it.

When installing the gear cover, make sure that the pin in the gear cover engages the metal lined (smooth) hole in the governor cup. Turn the governor cup so that the metal lined hole is at the three o'clock position. The smooth side of the governor yoke must ride against the governor cup. Turn the governor arm and shaft clockwise as far as possible and hold in this position until the gear cover is installed flush against the crankcase. Be careful not to damage the gear cover oil seal. Adjust the roll (stop) pin to protrude to a point 3/4" from the cover's mounting surface.

GOVERNOR CUP

With the gear cover removed, the governor cup can be taken off after removing the snap ring from the camshaft center pin. Catch the flyballs while sliding the cup off (Figure 27).

Replace with a new part, any flyball which is grooved or has a flat spot; the ball spacer if its arms are worn or otherwise damaged; and the governor cup if the race surface is grooved or rough. The governor cup must be a free spinning fit on the camshaft center pin, but without any excessive play.

When installing the governor cup, tilt the engine so the gear is up, put the flyballs in place (equally spaced) and install the cup and snap ring on the center pin.

The camshaft center pin extends out 3/4" from the end of the camshaft. This distance provides an in and out travel distance of 7/32" for the governor cup, as illustrated. Hold the cup against the flyballs when measuring. If the distance is less (the engine will race especially at no load) remove the center pin and press in a new pin or grind off the hub of the cup as required. The camshaft center pin cannot be pulled outward or removed without damage. If the center pin extends out too far, the cup will not hold the flyballs properly.

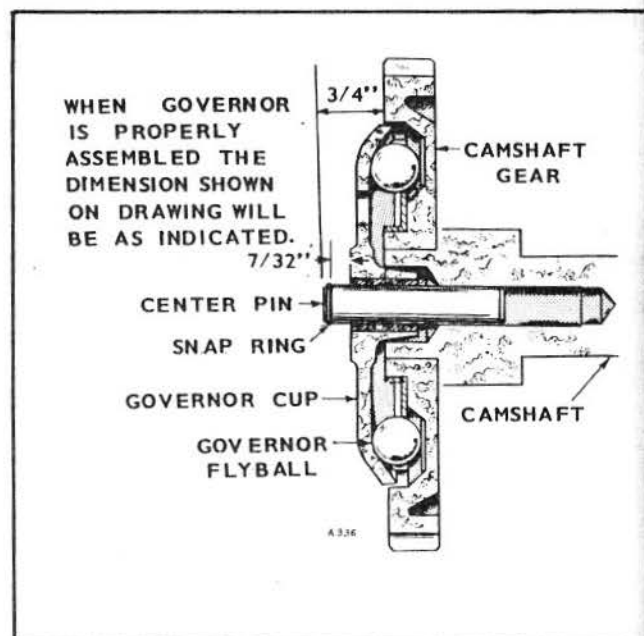

FIGURE 27. GOVERNOR CUP DETAIL

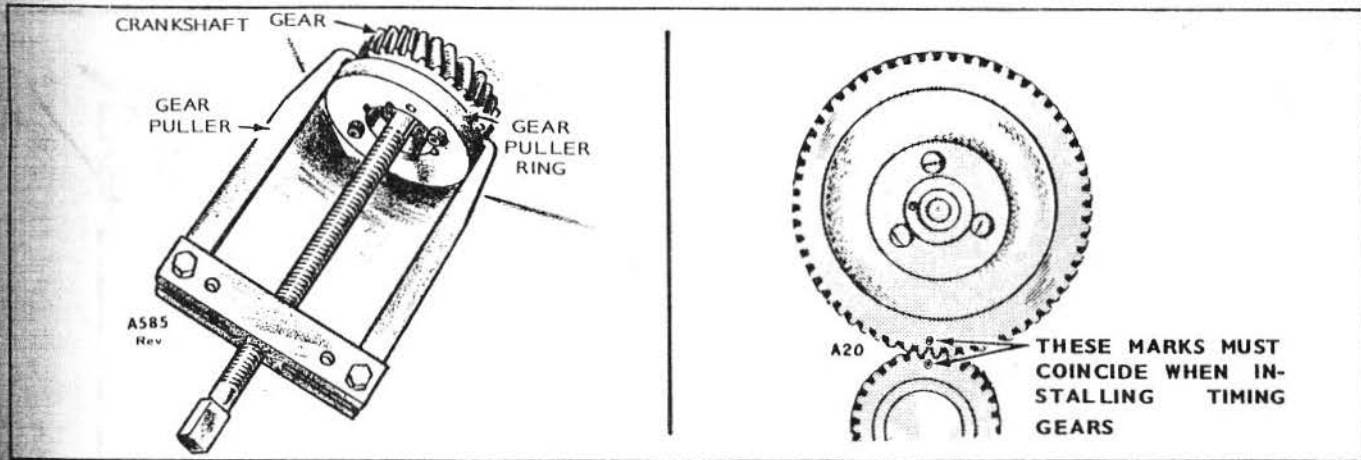

FIGURE 28. TIMING GEAR REMOVAL AND INSTALLATION

TIMING GEARS

If replacement of either the crankshaft gear or the camshaft gear becomes necessary, always install both gears new.

To remove the crankshaft gear, first remove the snap ring and retainer washer, then attach the gear pulling ring using two No. 10-32 screws (Figure 28). Tighten the screws alternately until both are tight. Attach a gear puller to the puller ring and proceed to remove the gear.

The camshaft and gear must be replaced as an assembly. Before removing the camshaft and gear assembly, remove the cylinder head and valve assemblies. Then remove the operating plunger for the breaker points and tappets.

Each timing gear is stamped with O near the edge. The gear teeth must mesh so that these marks exactly coincide when the gears are installed in the engine. When installing the camshaft gear and shaft assembly, be sure that the thrust washer is properly in place behind the camshaft gear. Then install the crankshaft retaining washer and lock ring.

PISTONS AND CONNECTING RODS

Observe the following procedure when removing pistons and connecting rods from the engine.

1. Drain oil.
2. Remove the cylinder head and oil base pan from the engine.
3. Remove the ridge from the top of each cylinder with a ridge reamer before attempting piston removal (Figure 29).

CAUTION

Forcing the piston from the cylinder before reaming may cause damage to the piston lands and break rings.

4. Turn the crankshaft until the piston is at the bottom of its stroke and remove the connecting rod nuts. Lift the rod bearing cap from the rod and push the rod and piston assembly out through

the top of the cylinder using a hammer handle. Avoid scratching the crankpin and cylinder wall when removing the piston and rod.

Note: Mark each piston and rod assembly so they can be returned to their respective cylinders after overhaul. Keep connecting rod bearing caps with their respective rods.

5. Remove the piston rings from the piston with a piston ring spreader as shown in Figure 30. Remove the piston pin retainer and push the piston pin out.

Remove dirt and deposits from the piston surfaces with an approved cleaning solvent. Clean the piston ring grooves with a groove cleaner or the end of a piston ring filed to a sharp point (Figure 31). Care must be taken not to remove metal from the groove sides.

CAUTION

Do not use a caustic cleaning solvent or wire brush for cleaning pistons. These materials will cause piston damage.

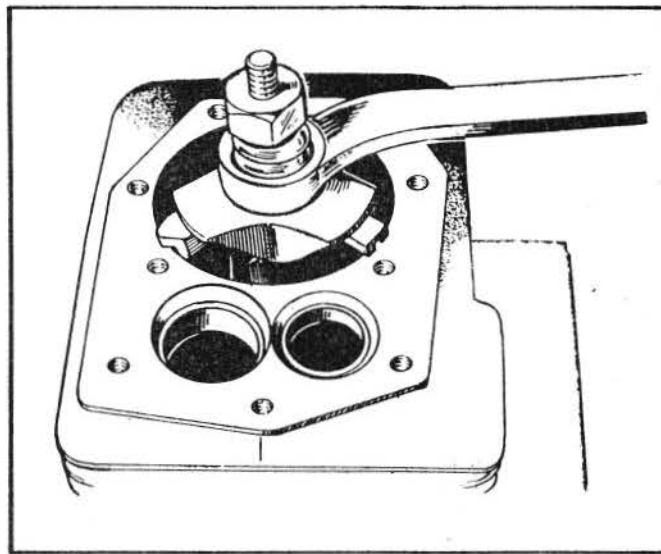

FIGURE 29. REMOVING RIDGE FROM THE CYLINDER

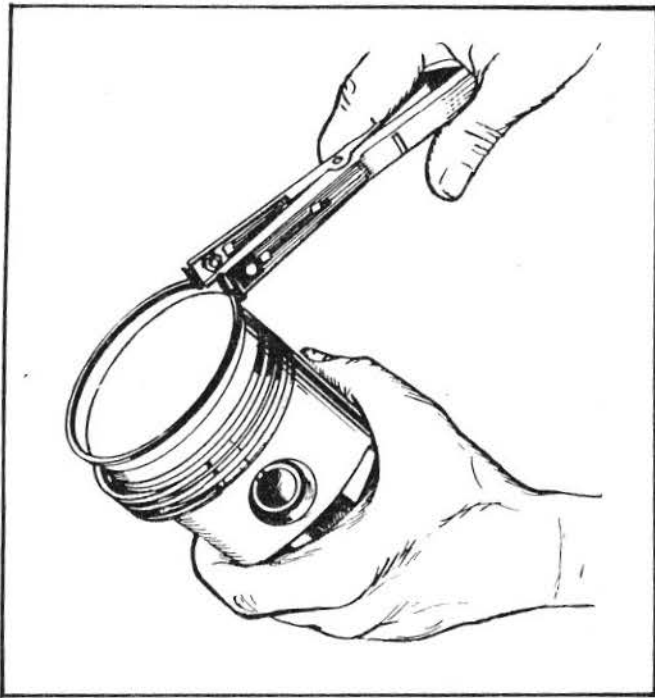

FIGURE 30. REMOVING PISTON RINGS

When cleaning the connecting rods in solvent, include the rod bore. Blow out all passages with compressed air.

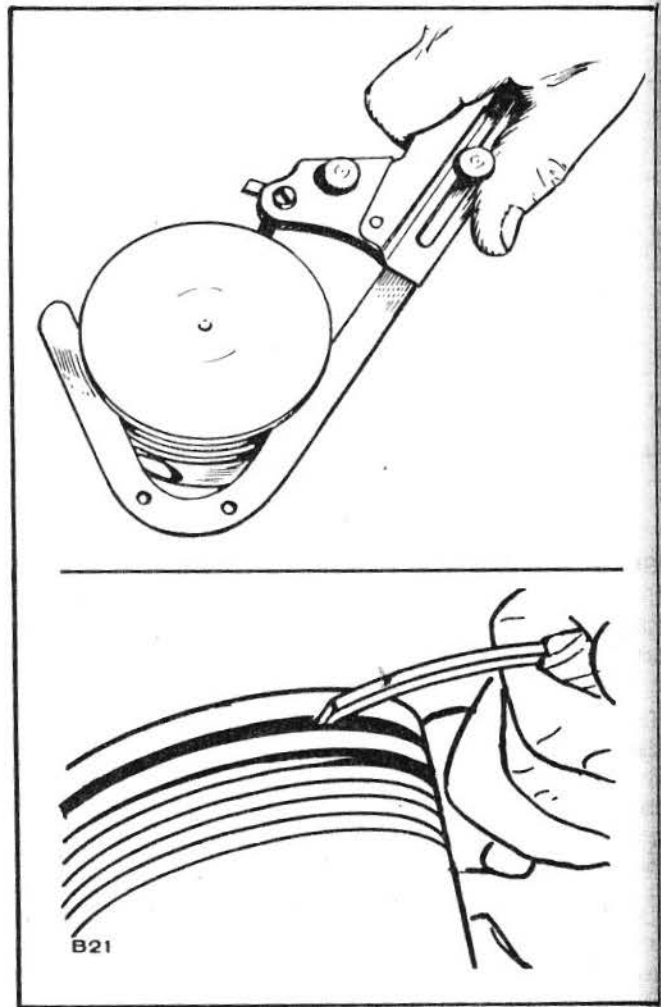

FIGURE 31. PISTON GROOVE CLEANING

Inspection:

The following text contains inspection procedures concerning pistons and connecting rods.

1. Piston Inspection:

- a. Inspect the pistons for fractures at the ring lands, skirts and pin bosses. Check for wear at the ring lands using a new ring and feeler gauge as shown in Figure 32. Replace the piston when the side clearance of the top compression ring reaches 0.008".
- b. Replace pistons showing signs of scuffing, scoring, worn ring lands, fractures or damage from preignition. Excessive piston wear near the edge of the top ring land indicates pre-ignition.

2. Connecting Rod Inspection

- a. Replace connecting rod bolts and nuts with damaged threads. Replace connecting rods with deep nicks, signs of fractures, scored bores or bores out of round more than 0.002".
- b. Use a new piston pin to check connecting rod for wear. A push fit clearance is required and varies from engine to engine. If a new piston pin falls through a dry rod pin bore as a result of its own weight, replace the rod.

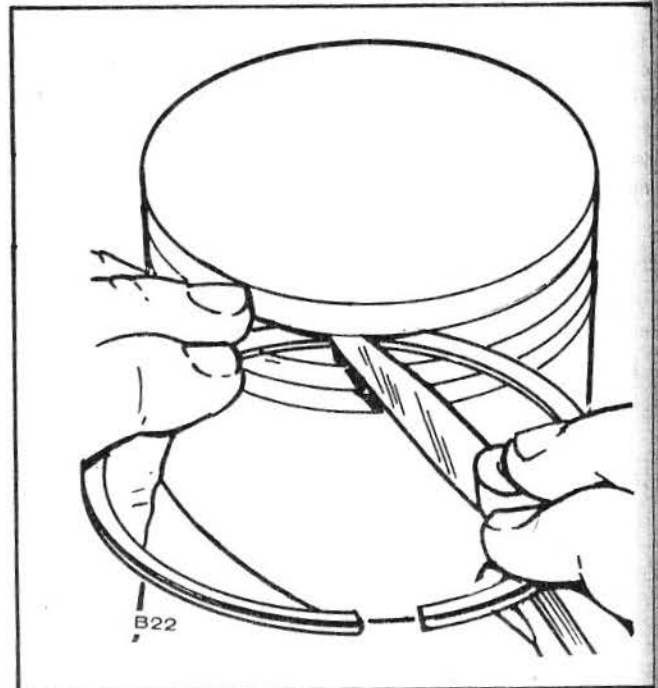

FIGURE 32. CHECKING RING SIDE CLEARANCE

1. F
a
b
2. F
a
b.
CYLIN
1. Ma
ma
wi
oil
co
wo
co
are
2. Ins
We
bre
3. Ch
an
ga
me
top

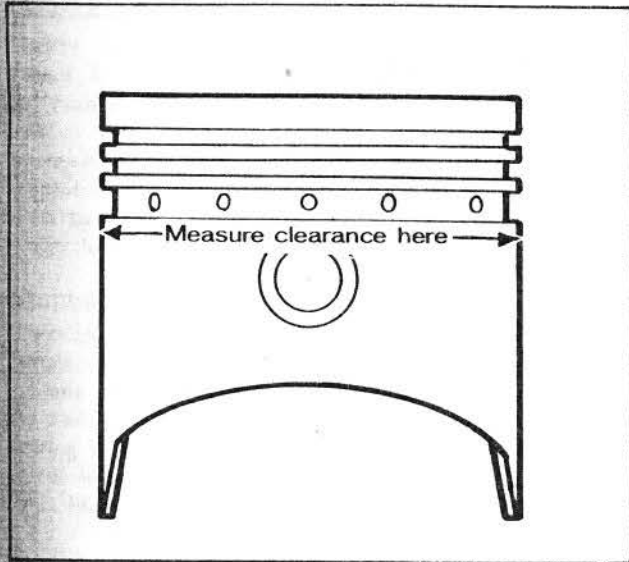

FIGURE 33. MEASURING PISTON CLEARANCE

1. Fitting Pistons:

- a. Proper piston tolerances must be maintained for satisfactory operation.
- b. Measure the piston to cylinder clearance as shown in Figure 33 to be sure the total clearance follows specifications.

2. Fitting Piston Rings:

- a. Install the piston ring in the cylinder bore. Invert the piston and push the ring to the end of ring travel, about halfway into the bore, which trues the ring end gap. Check the gap with a feeler gauge as shown in Figure 34.
- b. The practice of filing ring ends to increase the end gap is not recommended. If the ring end gap does not meet specifications, check for the correct set of rings and the correct bore size. A cylinder bore that is 0.001 " under size will reduce the end gap 0.003 " .

CYLINDER BLOCK

1. Make a thorough check for cracks. Minute cracks may be detected by coating the suspected area with a mixture of 25% kerosene and 75% light motor oil. Wipe the part dry and immediately apply a coating of zinc oxide (white lead) dissolved in wood alcohol. If cracks are present, the white coating will become discolored at the defective area.
2. Inspect the cylinder bore for scoring. Check the Welsh plugs for a tight, even fit and the fins for breakage.
3. Check the cylinder bore for taper, out of round and wear, with a cylinder bore gauge, telescope gauge or inside micrometer (Figure 35). These measurements should be taken at four places - the top and bottom of piston ring travel.

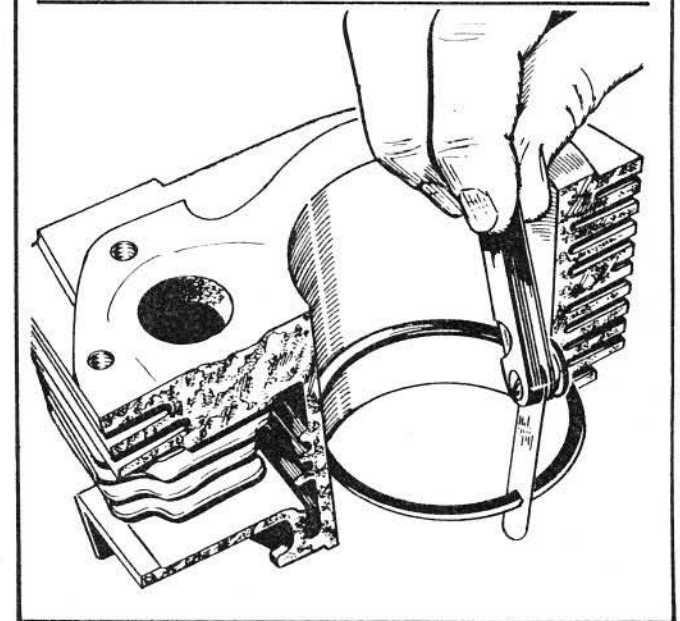
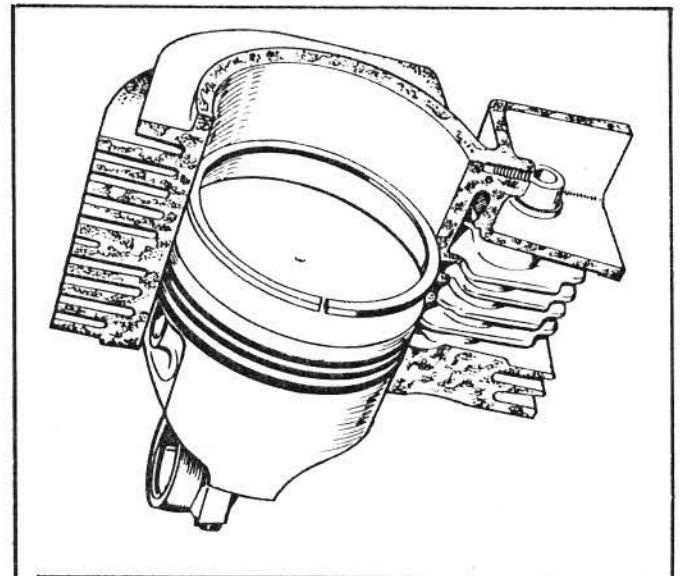

FIGURE 34. POSITIONING OF PISTON RING AND MEASURING OF END GAP

4. Record measurements taken lengthwise at the top and bottom of the piston travel as follows:
 - a. Lengthwise of the block, measure and record as "A" the diameter of the cylinder at the top of the cylinder where greatest ring wear occurs.
 - b. Also, lengthwise of the block, measure and record as "B" the cylinder diameter at the piston skirt travel.
 - c. Crosswise of the block, measure and record as "C" the diameter of the top of the cylinder at the greatest point of wear.
 - d. Measure and record as "D" the diameter at the bottom of the cylinder bore and crosswise of the block.
 - e. Reading "A" compared to reading "B" and reading "C" compared to reading "D" indicates cylinder taper.

CRANKSHAFT

Inspect the bearing journals. If they are scored and cannot be smoothed out by dressing down, replace the crankshaft.

Whenever making major repairs on the engine, always inspect the drilled passages of the crankshaft. Clean them to remove any foreign material and to assure proper lubrication of the connecting rods.

BEARINGS (Figures 37-39)

Removing camshaft or crankshaft bearings requires complete disassembly of the engine. Use a press or a suitable drive plug to remove the bearings. Support the casting to avoid distortion and avoid damaging the bearing bore during removal and installation. Use oil on the bearings to reduce friction when installing and again lubricate with oil after installing.

New camshaft bearings are precision type which *do not* require line reaming or line boring after installation. Coat the bearing with SAE20 oil to reduce friction. Place the bearing on the crankcase over the bearing bore with the elongated hole in proper position and narrow section facing out (except bores without oil holes install with bearing groove at the top). Be sure to start the bearing straight. Press the front bearing in flush with the outside end of the bearing bore. Press the rear bearing in flush with the bottom of counterbore which received the expansion plug (see Figure 37).

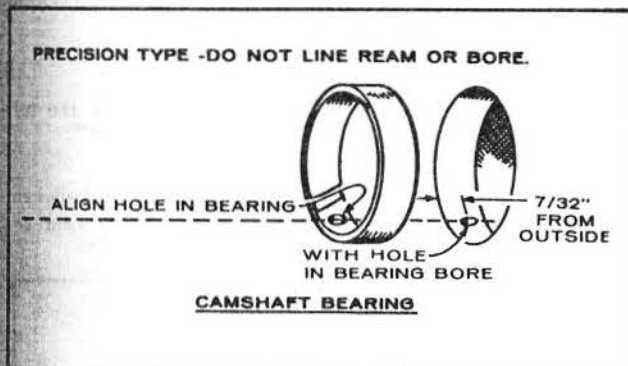

FIGURE 37. CAMSHAFT BEARING

Crankshaft main bearings are precision type which do not require line reaming or line boring after installation. They are available in standard size and .002" undersize. Expand the bearing bore by placing the casting in hot water or in an oven heated to 200°F.

CAUTION

If a torch is used, apply only a little heat. Distortion will result from too much local heat.

To ease assembly, cool the precision bearing to shrink it. Align the oil hole(s) in the bearing with the oil hole(s) in the bearing bore. The oil passage must be at least 1/2 open. Lubricate bearings with SAE20 oil before installing. The cold oiled precision bearing should require only light taps to position it with a

driving tool. If head of lock pin is damaged, use side cutters or Easy Out tool to remove and install new pin. Apply oil to thrust washer (one used with each bearing) to hold it in place while installing the crankshaft. Oil grooves in thrust washers must face the crankshaft and washers must be flat (not bent). The two notches on each washer must fit over the two lock pins to prevent riding on the crankshaft.

Note: Original front bearing uses a separate thrust washer. Replacement front bearing is a one piece assembly with thrust washer part of the bearing. Do not use a separate thrust washer when installing this replacement part. See Figures 38 and 39.

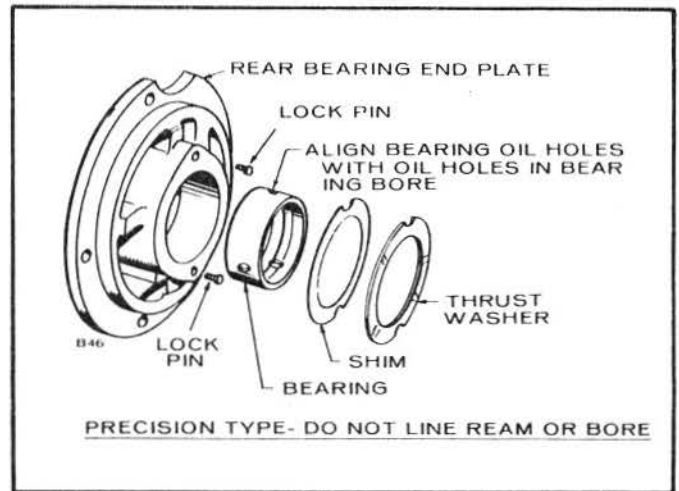

FIGURE 38. BEARINGS FOR REAR BEARING PLATE

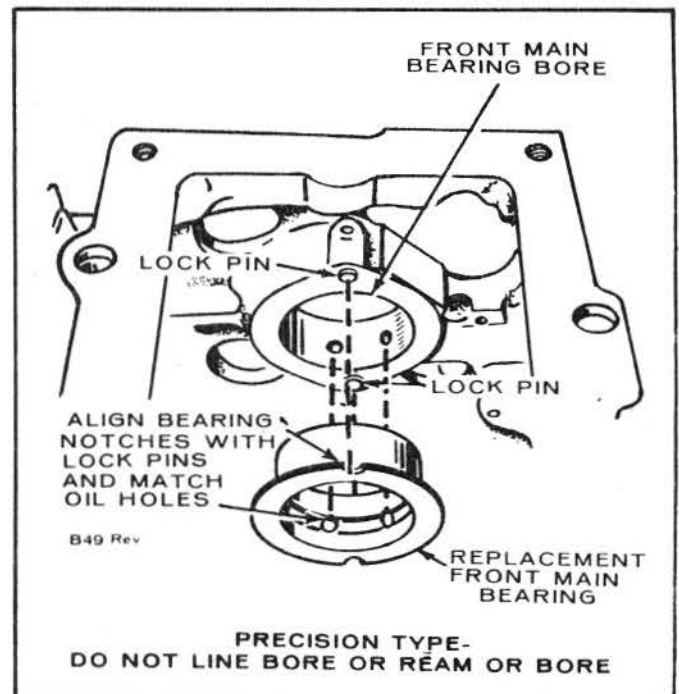

FIGURE 39. FRONT MAIN BEARING INSTALLATION

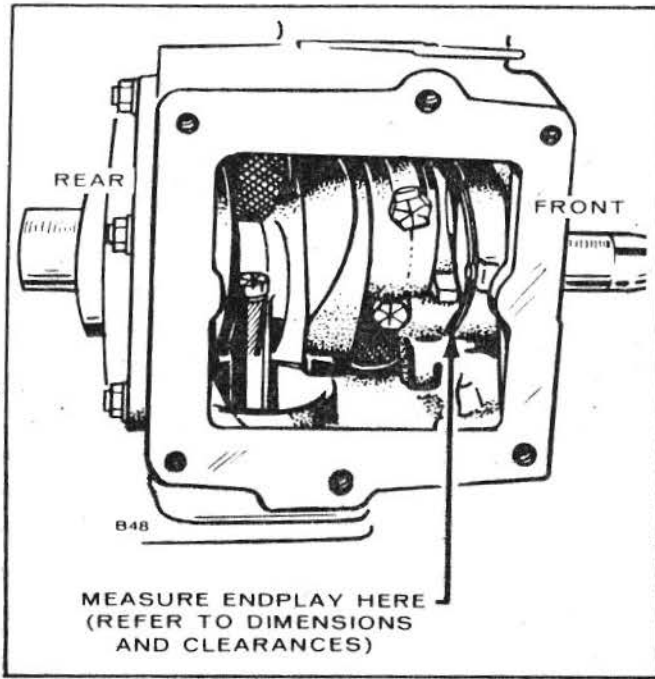

FIGURE 40. CRANKSHAFT ENDPLAY

CRANKSHAFT ENDPLAY

After the rear bearing end plate has been tightened using the torque recommended in Assembly Torques check the crankshaft endplay as shown in Figure 40. If there is too much endplay (see Dimensions and Clearances for minimum and maximum endplay), remove the rear bearing end plate and add a shim between the thrust washer and plate. Reinstall the end plate making sure the thrust washer and shim notches line up with the lock pins. Torque and recheck endplay of the crankshaft.

Checking Bearing Clearance with Plastigauge:

1. Make certain that all parts are marked or identified so that they are reinstalled in their original positions.

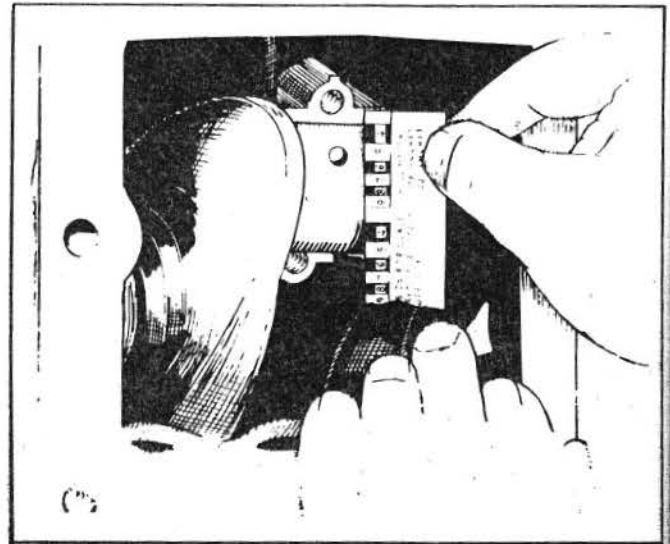

FIGURE 41. MEASURING BEARING CLEARANCE

2. Place a piece of correct size Plastigauge in the bearing cap the full width of the crankshaft rod surface about 1/4 inch off center (Figure 41).
3. Rotate the crank about 30° from bottom dead center and reinstall the bearing cap; tighten the bolts to the torque specified in the Table of Torques and Clearances. Do not turn the crankshaft.
4. Remove the bearing cap. Leave the flattened Plastigauge on the part to which it has adhered and compare the widest point with the graduations on the Plastigauge envelope to determine bearing clearance.

OIL SEALS (Figure 42)

The bearing plate must be removed to replace the oil seal. Drive the oil seal out from the inside.

Before installing the seals, fill the space between lips with a multi-purpose grease. This will improve sealing.

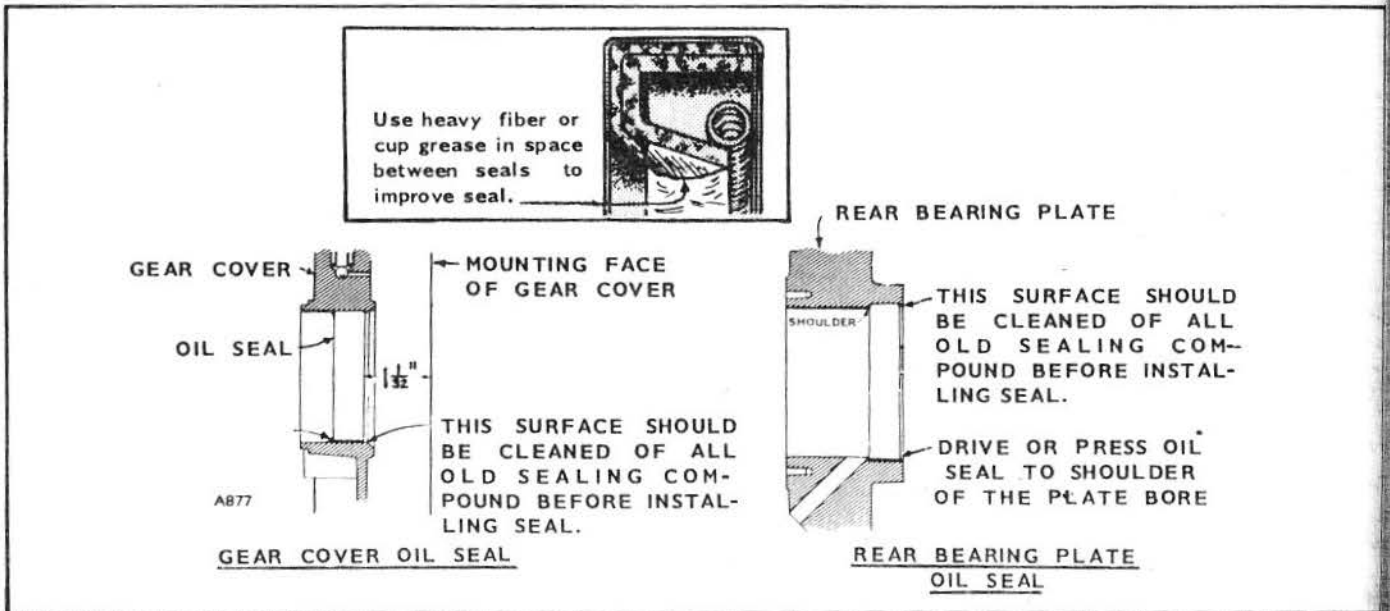

FIGURE 42. GEAR COVER AND REAR BEARING PLATE OIL SEALS

W
i
t
h
W
s
e
s
p
l
c
r
d
a
s
A
S
1.
2.
3.

I
N
S
T
A
L
1.
T
u
b
e
2.
L
u
b
r
i
c
a
t
e
3.
P
o
s
i
t
i
o
n
c
y
l
i
n
d
e
r
b
o
r
e

When installing the gear cover oil seal, tap the seal inward until it is 1-1/32" from the mounting face of the cover.

When installing the bearing plate oil seal, tap the seal into the bearing plate bore to bottom against the shoulder in the plate bore. Use a seal expander or place a piece of shim stock around the end of the crankshaft, when replacing the bearing plate to avoid damaging the seal. Remove the shim stock as soon as the plate is in place.

ASSEMBLY

1. Lubricate all parts with engine oil.
2. Position piston on its respective rod and install the pin.
3. Install the rings on the pistons starting with the oil control ring (Figure 43). Use a piston ring spreader to prevent twisting or excessive expansion of the ring. Some oil control rings and all compression rings have a dot or the word "top" on one side of the ring to indicate which side faces the top of the piston. Unmarked piston rings can be installed either way. If the oil control ring has an expander, install the expander first and then close until the expander ends butt. The joint should be 180° from the gap of that ring.

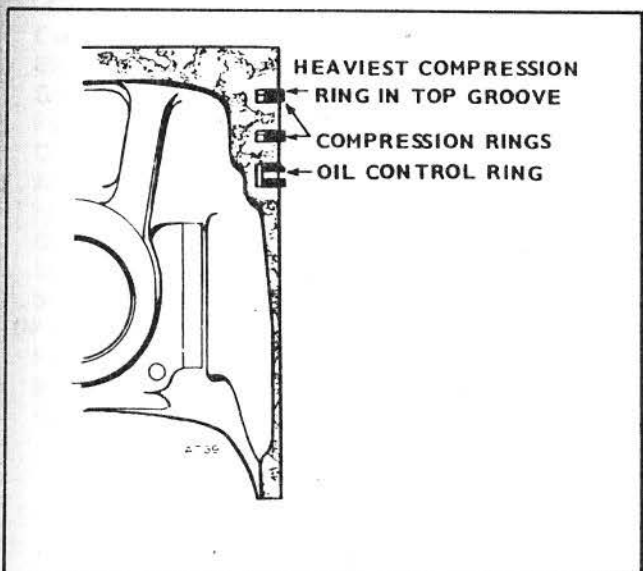

FIGURE 43. PISTON RINGS

INSTALLATION OF PISTON IN CYLINDER:

1. Turn the crankshaft to position the number one rod bearing journal at the bottom of its stroke.
2. Lubricate the number one piston assembly and inside of the cylinder. Compress the rings with a ring compressor as shown in Figure 44.
3. Position the piston and rod assembly in the cylinder block.

NOTE: The connecting rod bearing caps should always face away from the camshaft or bottom side of engine. Rod bolts are off-set toward outside of block.

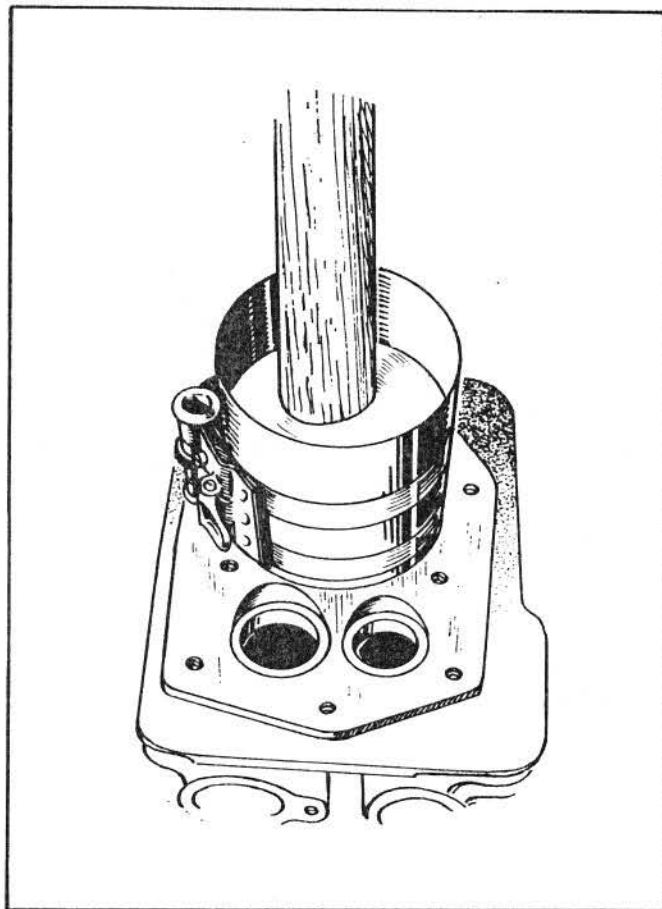

FIGURE 44. INSTALLING PISTON

4. Tap the piston down into the bore with the handle end of a hammer until the connecting rod is seated on the journal (Figure 44). Install the bearing cap on the rod with the witness marks and stamped reference numbers matching the marks on the rod. Install and tighten the bolts evenly in steps to the specified torques.

The bearing cap must be tapped to properly align it with the rest of the connecting rod. Clearance varies on the journal if this is not done.

Install the remaining piston and rod in the same manner. Crank the engine over by hand to see that all bearings are free.

5. Install the oil base with a new gasket.
6. Install the cylinder heads and torque 14-16 ft. lb.
7. Replace oil and break-in engine.

CYLINDER HEADS

Remove the cylinder heads for cleaning each 200 hours or when poor engine performance is noticed.

1. Use a 1/2 inch socket wrench to remove cylinder head nuts. Lift heads off.

CAUTION Do not remove heads when they are hot. Warpage may occur.

2. After removing heads, clean out all carbon deposits. Be careful not to damage the outer sealing edges where gaskets fit. The heads are made of aluminum and can be damaged by careless handling.
3. Use new head gaskets and clean both the heads and the cylinder block thoroughly where the head gaskets rest.
4. Place heads in position and follow head torque tightening sequence shown in Figure 45. Start out tightening all Nuts to 5 ft-lb, then 10 ft-lb, etc., until all Nuts are torqued 14-16 ft-lb.
5. Recheck torque before engine has run a total of 25 hours.

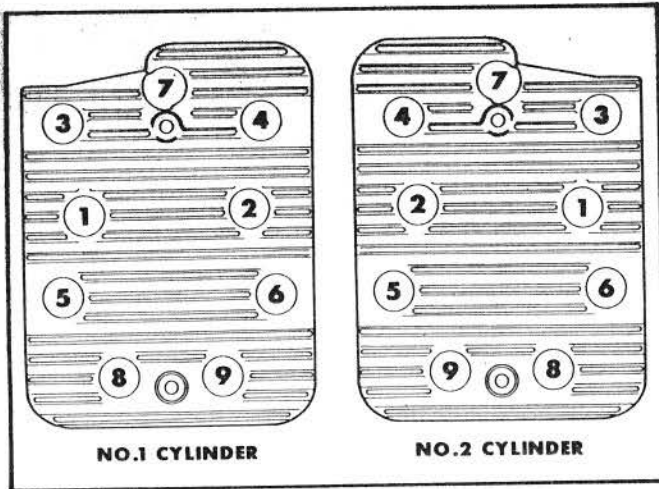

FIGURE 45. CYLINDER HEAD TORQUE SEQUENCE

This
illus
that
cata
betw

TIT
INT
ST/
C
B
C
F
C
A
I
S
S
S
O
P
F
B
C

INTRODUCTION

This catalog applies to Tractor Application BF Engines. Parts are arranged in groups of related items. Each illustrated part is identified by a reference number corresponding to the same reference number in the parts list for that group. Parts illustrations are typical. Using the *Model* and *Spec No.* from the nameplate, select parts from this catalog that apply to your engine. Unless otherwise mentioned in the description, parts are interchangeable between models. Right and left sides are determined by facing the blower end (front) of the engine.

TABLE OF CONTENTS

TITLE	PAGE	
INTRODUCTION	29	
STANDARD ENGINE GROUPS	29	
Camshaft, Crankshaft, Flywheel and Piston	31	
Block, Cylinder	32,33	
Gearcase, Oil Base and Oil Pump	34,35	
Fuel System	36,37	
Carburetor Parts	38,39	
Alternator, Blower Housing, Governor and Starter	40,41	
Ignition System	42	
Starter Parts - Spec A	43	
Starter Parts - Begin Spec B	44	
Service Kits and Miscellaneous	44	Optional Group
OPTIONAL EQUIPMENT GROUPS	45	Number
Filter, Oil - Spin-On	46	1
Box, Breaker - Top Adjusted	47	2
Carburetor with Integral Fuel Pump	48,49	3

STANDARD ENGINE PARTS SECTION

This section contains the engine parts used on standard engines.

GENERAL INFORMATION

For parts or service, contact the dealer from whom you purchased this equipment or refer to your Nearest Authorized Onan Parts and Service Center.

To avoid errors or delay in filling your parts order, please furnish all information requested.

Always refer to the nameplate on your unit.

1. Always give the MODEL, SPEC NO. and SERIAL NO.

The diagram shows a rectangular nameplate with two circular mounting holes at the top. The Onan logo is prominently displayed in the upper left. Below the logo is a large rectangular box labeled "MODEL AND SPEC NO.". Below that is a smaller rectangular box labeled "SERIAL NO.". The bottom right corner of the nameplate is folded over. The reference number "M-1149" is printed at the bottom right of the nameplate.

For handy reference, insert "YOUR" nameplate information in the spaces above.

2. Do not order by reference number; always use part number and description.
3. Give the part number, description and quantity needed of each item. If an older part cannot be identified, return the part prepaid to your dealer or nearest Onan Parts and Service Center. Print your name and address plainly on the package. Write a letter to the same address stating the reason for returning the part.
4. State definite shipping instructions. Any claim for loss or damage to your unit in transit should be filed promptly against the transportation company making the delivery. Shipments are complete unless the packing list indicates items are back ordered.

REF. NO.
1
2
3
4
5
6
7
8
9
10
11
12
13
14

CAMSHAFT, CRANKSHAFT, FLYWHEEL AND PISTON

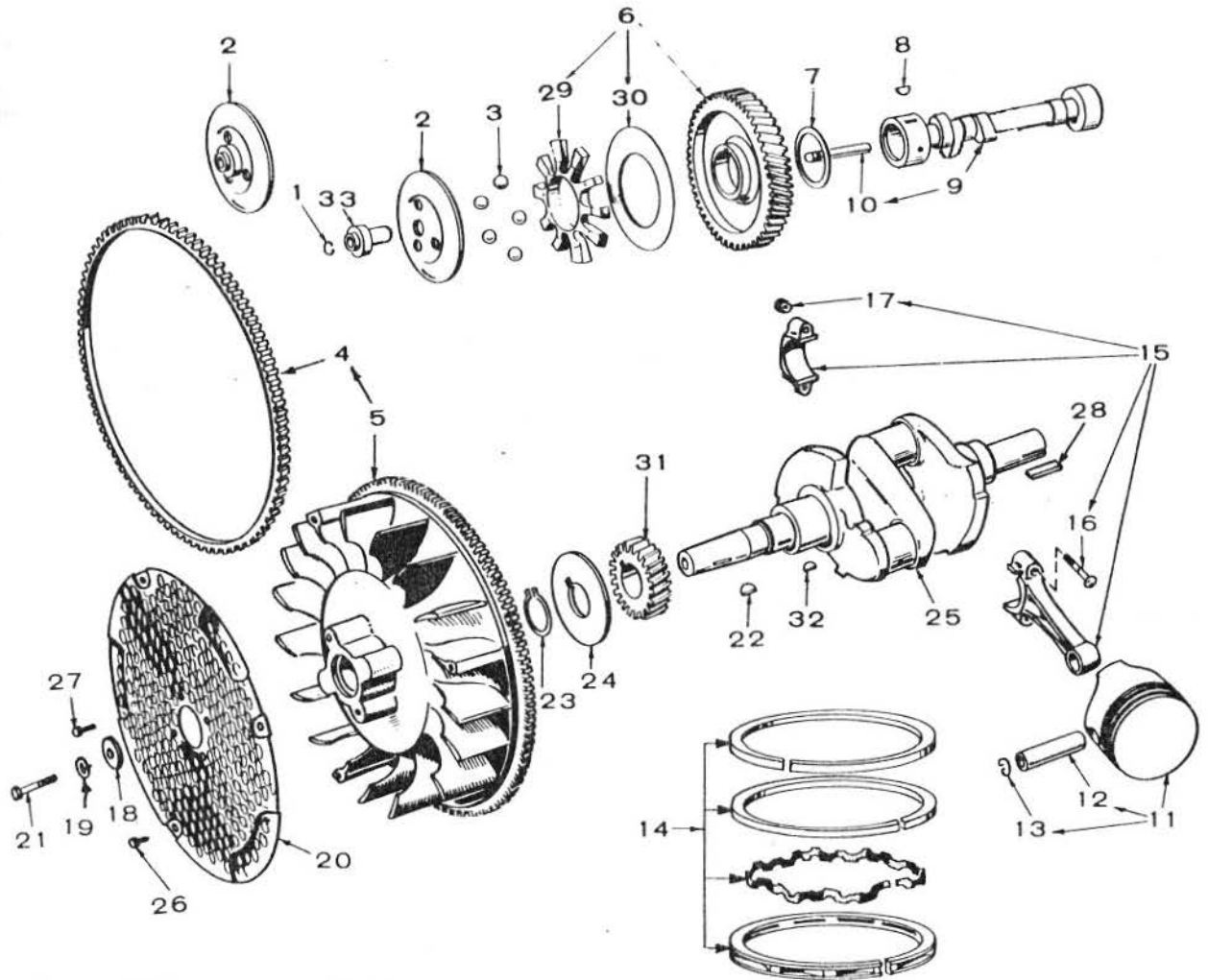

REF. NO.	PART NO.	QTY. USED	PART DESCRIPTION
1	150-0078	1	Ring, Retaining
2	CUP, GOVERNOR		
	150-1520	1	Begin Spec F
	150-1116	1	Spec A through E
3	510-0015	5	Ball, Governor
4	104-0779	1	Gear, Ring
5	134-2432	1	Flywheel (Includes Ring Gear)
6	105-0332	1	Gear, Camshaft
7	105-0004	1	Washer, Thrust
8	515-0001	1	Key, Camshaft Gear Mounting
9	105-0402	1	Camshaft (Includes Center Pin)
10	150-0075	1	Pin, Center - Camshaft
11	PISTON (Includes Pin and Retaining Rings)		
	112-0134	2	Standard
	112-0134-05	2	.005" Oversize
	112-0134-10	2	.010" Oversize
	112-0134-20	2	.020" Oversize
	112-0134-30	2	.030" Oversize
	112-0134-40	2	.040" Oversize
12	112-0122	2	Pin, Piston
13	518-0311	4	Ring, Retaining
14	RING SET, PISTON		
	113-0174	2	Standard
	113-0174-05	2	.005" Oversize
	113-0174-10	2	.010" Oversize
	113-0174-20	2	.020" Oversize
	113-0174-30	2	.030" Oversize
	113-0174-40	2	.040" Oversize

REF. NO.	PART NO.	QTY. USED	PART DESCRIPTION
15	ROD, CONNECTING (Includes Bolt and Nut)		
	114-0225	2	Standard
	114-0225-10	2	.010" Undersize
	114-0225-20	2	.020" Undersize
	114-0225-30	2	.030" Undersize
16	114-0228	4	Bolt, Special - Connecting Rod
17	870-0137	4	Nut, Locking - Connecting Rod
18	526-0017	1	Washer, Flat (7/16)
19	850-0055	1	Washer, Lock - Spring (7/16)
20	134-2384	1	Guard, Flywheel
21	104-0170	1	Screw, Hex Head (7/16-14 x 4")
22	515-0227	1	Key, Flywheel Mounting
23	518-0014	1	Ring, Retaining
24	104-0043	1	Washer, Gear Retaining
25	104-0889	1	Crankshaft (Also order Key Kit 515-0227 for Spec A through C replacement)
26	821-0010	3	Screw, Hex Washer Head (1/4-20 x 1/2")
27	821-0014	2	Screw, Hex Washer Head (5/16-18 x 1/2")
28	515-0103	1	Key, Stub Shaft
29	150-1257	1	Spacer, Flyball
30	150-0077	1	Plate, Flyball
31	104-0032	1	Gear, Crankshaft
32	515-0001	1	Key, Crankshaft Gear Mounting
33	150-0078	1	Hub, Governor Cup - Begin Spec F

learest
 another free manual from www.searstractormanuals.com
 filed,
 press
 filed
 the

CYLINDER BLOCK

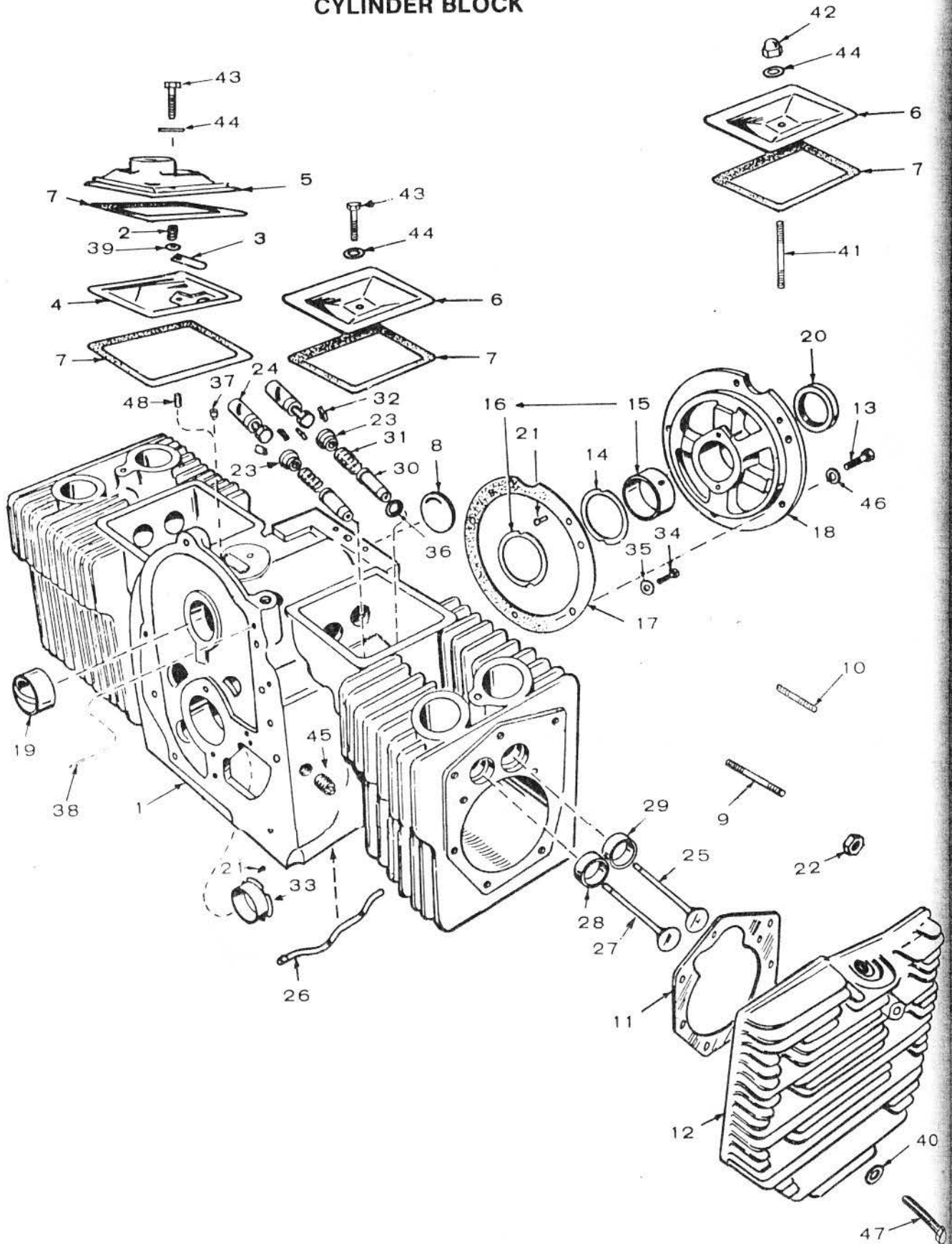

CYLINDER BLOCK

REF. NO.	PART NO.	QTY. USED	PART DESCRIPTION
1	BLOCK ASSEMBLY, CYLINDER (Includes Parts Marked †)		
	110-1943	1	Spec A through D (With Oil Filter Ports)
	110-2351	1	Begin Spec E (Without Oil Filter Ports)
2	123-1174	1	Spring, Breather Valve
3	123-1175	1	Reed, Breather Valve
4	123-1173	1	Baffle, Breather Valve
5	110-1878	1	Cover, Valve - with Breather Port
6	110-1879	1	Cover, Valve
7	110-1921	3	Gasket, Valve Cover
8	517-0048	1	†Plug, Welch (1-5/8")
9	520-0424	6	Stud (5/16 x 2 - 5/16") Spec A through E
10	520-0759	12	Stud (5/16 x 2 - 1/16") Spec A through E
11	110-1920	2	Gasket, Cylinder Head
12	HEAD, CYLINDER		
	110-1924	1	Right Side
	110-1925	1	Left Side
13	800-0051	5	†Screw, Hex Head (3/8-16 x 1-1/4")
14	104-0776	As Req.	†Shim (.005")
15	BEARING, SLEEVE - CRANKSHAFT, REAR (Includes Thrust Washer)		
	101-0450	1	†Standard
	101-0450-02	1	.002" Undersize
	101-0450-10	1	.010" Undersize
	101-0450-20	1	.020" Undersize
	101-0450-30	1	.030" Undersize
16	104-0575	2	†Washer, Thrust
17	101-0415	1	†Gasket, Bearing Plate
18	101-0439	1	†Plate, Bearing
19	101-0405	2	†Bearing, Sleeve - Camshaft
20	509-0041	1	†Seal, Oil - Crankshaft, Rear
21	516-0072	4	†Pin, Drive - Bearing Stop
22	110-0445	18	Nut, Hex (5/16-24) - Spec A through E
23	110-0893	4	Retainer, Spring
24	TAPPET, VALVE		
	115-0006	4	Standard
	115-0006-02	4	.002" Oversize
	115-0006-05	4	.005" Oversize
25	110-1808	2	Valve, Intake
26	120-0706	1	†Tube, Oil - Crankcase

REF. NO.	PART NO.	QTY. USED	PART DESCRIPTION
27	110-1809	2	Valve, Exhaust
28	INSERT, VALVE SEAT - EXHAUST		
	110-0245	2	†Standard
	110-0245-02	2	.002" Oversize
	110-0245-05	2	.005" Oversize
	110-0245-10	2	.010" Oversize
	110-0245-25	2	.025" Oversize
29	INSERT, VALVE SEAT - INTAKE		
	110-0197	2	†Standard
	110-0197-02	2	.002" Oversize
	110-0197-05	2	.005" Oversize
	110-0197-10	2	.010" Oversize
	110-0197-25	2	.025" Oversize
30	110-1935	4	†Guide, Valve
31	110-0539	4	Spring, Valve
32	110-0639	8	Lock, Valve Spring
33	*BEARING, FLANGED, SLEEVE - CRANKSHAFT, FRONT		
	101-0432	1	†Standard
	101-0432-02	1	.002" Undersize
	101-0432-10	1	.010" Undersize
	101-0432-20	1	.020" Undersize
	101-0432-30	1	.030" Undersize
34	800-0046	2	Screw, Hex Head (3/8-16 x 1/2")
35	526-0066	2	Washer, Flat - Copper (3/8)
36	110-0068	2	†Gasket, Valve Guide - Intake
37	517-0120	1	†Plug, Pipe - Crankcase Vacuum Port (Units with separate fuel pump)
38	516-0141	2	†Pin, Gearcase Align
39	526-0018	1	Washer, Flat (1/4)
40	526-0122	18	Washer, Flat (5/16)
41	520-0757	2	Stud (1/4 x 2-1/16") - Spec A through C
42	866-0001	2	Nut, Acorn (1/4-20) - Spec A through C
43	800-0010	2	Screw, Hex Head (1/4-20 x 1-3/4") - Begin Spec D
44	526-0063	2	Washer, Flat - Copper (1/4)
45	502-0080	1	Plug, Pipe - Square Head
46	850-0050	5	†Washer, Lock - Spring (3/8")
47	SCREW, CAP - HEX HEAD - Begin Spec F		
	800-0540	6	Special
	800-0541	12	Special
48	149-1299	1	†Tube, Crankcase Vacuum Port (Units with integral fuel pump)

† - Included in Cylinder Block Assembly.

* - Flanged bearing replaces thrust washer and the unflanged front crankshaft bearing.

www.searstrackmanuals.com

GEARCASE, OIL BASE AND OIL PUMP

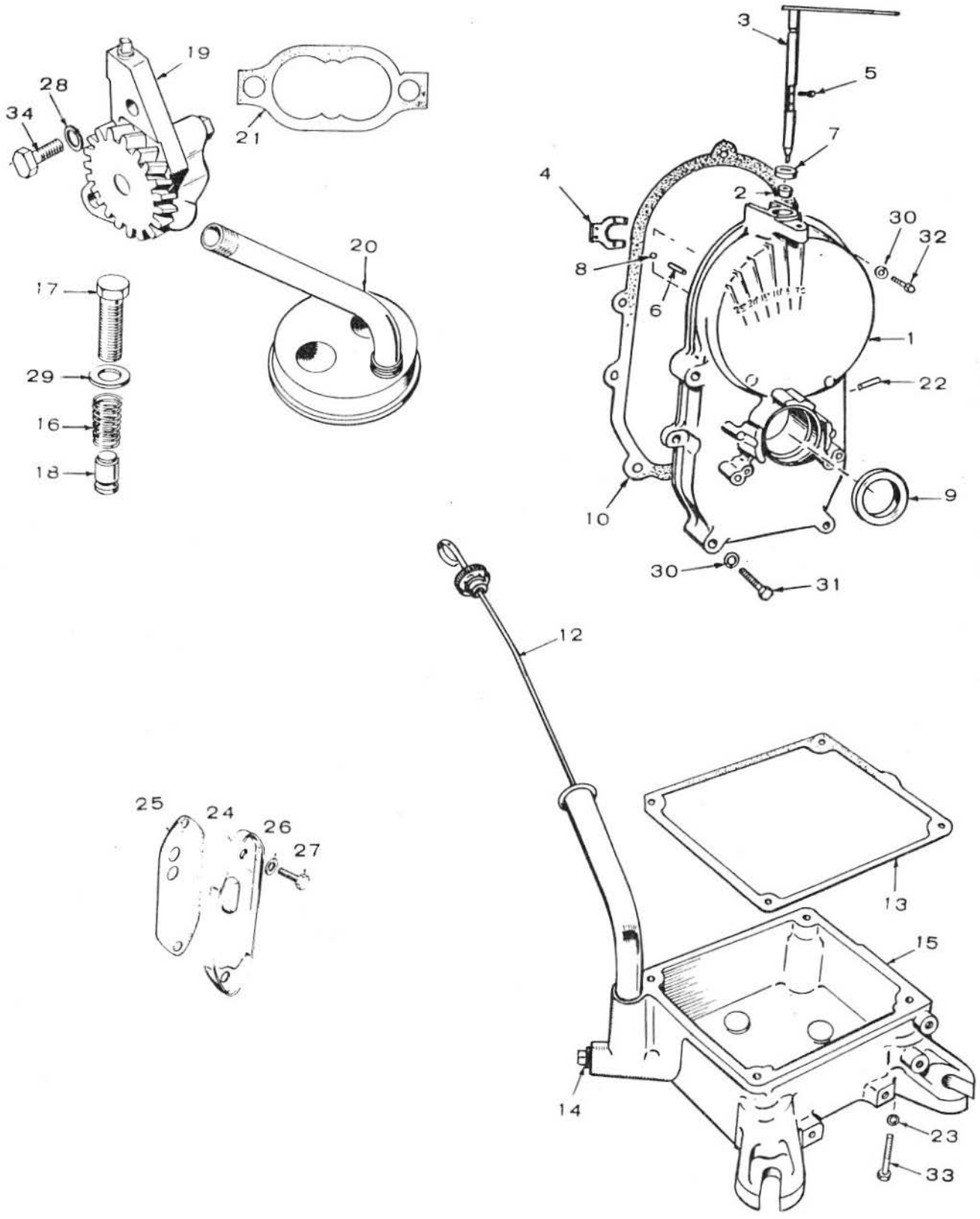

REF. NO.
1
2
3
4
5
6
7
8
9
10
12
13
14
15
16
17

another free manual from www.searstractormanuals.com

GEARCASE, OIL BASE AND OIL PUMP

REF. NO.	PART NO.	QTY. USED	PART DESCRIPTION	REF. NO.	PART NO.	QTY. USED	PART DESCRIPTION
1	GEARCASE ASSEMBLY (Includes Parts Marked *)			18	120-0398	1	Plunger, Bypass Valve
	103-0501	1	Engines With Separate Fuel Pump	19	120-0491	1	Pump, Oil (Internal parts not sold separately)
	103-0409	1	Begin Spec D	20	120-0713	1	Cup, Oil Pump Intake
			Spec A through C	21	120-0161	1	Gasket Kit - Oil Pump
			Engines With Carburetor and Integral Fuel Pump (Does not include vacuum line tube)	22	149-1299	1	*Tube, Vacuum Line - Gearcase port
	103-0498	1	Begin Spec D	23	850-0050	4	Washer, Lock - Spring (3/8)
	103-0396	1	Spec A through C	24	122-0359	1	Cover, Oil Outlet - Spec A thru D
2	510-0105	1	*Bearing, Sleeve - Governor Shaft	25	122-0321	1	Gasket, Oil Outlet - Spec A thru D
3	*SHAFT AND ARM ASSEMBLY - GOVERNOR			26	526-0122	2	Washer, Flat (5/16) - Spec A thru D
	150-1470	1	Begin Spec D	27	800-0026	2	Screw, Hex Head - Spec A thru D (5/16-18 x 3/4")
	150-1349	1	Spec A through C	28	850-0040	2	Washer, Lock - Spring (1/4)
4	150-1187	1	*Yoke, Shaft - Governor	29	526-0066	1	Washer, Flat - Copper (3/8)
5	815-0046	2	*Screw, Pan Head (8-32 x 3/8")	30	526-0065	5	Washer, Flat - Copper (5/16)
6	516-0130	1	*Pin, Dowel - Cup Stop	31	800-0032	4	Screw, Hex Head (5/16-18 x 1-3/4)
7	509-0008	1	*Seal, Oil - Governor Shaft	32	800-0034	1	Screw, Hex Head (5/16-18 x 2-1/4")
8	510-0014	1	*Ball, Bearing - Governor Shaft	33	800-0056	4	Screw, Hex Head (3/8-16 x 2-1/2")
9	509-0040	1	*Seal, Oil - Crankshaft	34	800-0007	2	Screw, Hex Head (1/4-20 x 1")
10	103-0408	1	Gasket, Gearcase				
12	123-1138	1	Cap and Indicator, Oil Fill				
13	102-0693	1	Gasket, Oil Base				
14	505-0056	2	Plug, Pipe - Oil Drain				
15	102-0730	1	Base, Oil - Includes Plugs				
16	120-0140	1	Spring, Bypass Valve				
17	801-0050	1	Screw, Hex Head (3/8-24 x 1") - Bypass Valve				

* - Included in Gearcase Assembly

FUEL SYSTEM

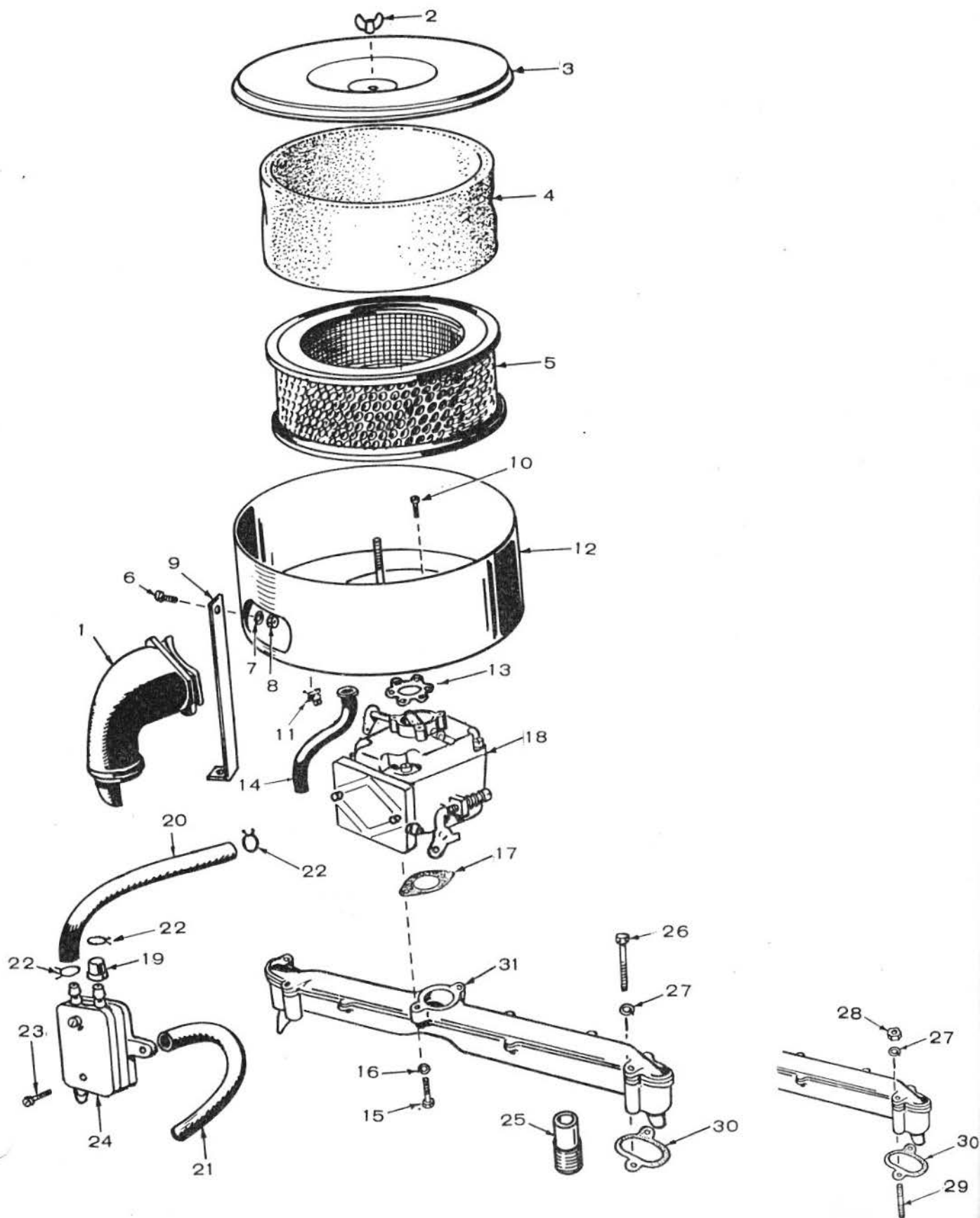

F
I

1
1
1
1
1
1
1
1

another free manual from www.searstractormanuals.com

FUEL SYSTEM

REF. NO.	PART NO.	QTY. USED	PART DESCRIPTION	REF. NO.	PART NO.	QTY. USED	PART DESCRIPTION
1	140-1169	1	Tube, Air Intake	19	149-1321	1	Cap, Fuel Outlet
2	865-0020	1	Nut, Wing (1/4-20)	20	503-0664	1	Hose, Fuel - Pump to Carburetor
3	140-1168	1	Cover, Air Cleaner	21	503-0663	1	Hose, Vacuum - Pump to Gearcase Port
4	140-1218	1	Filter, Air - Polyurethane	22	503-0301	3	Clamp, Hose (7/16")
5	140-1216	1	Filter, Air - Paper	23	809-0045	2	Screw, Round Head (#10 x 5/8")
6	800-0003	1	Screw, Hex Head (1/4-20 x 1/2")	24	149-1322	1	*Pump, Fuel - Vacuum, Pulse
7	853-0013	1	Washer, Lock - Spring (1/4)	25	505-0755	2	Nipple, Pipe (1 x 3") - Exhaust
8	862-0001	1	Nut, Hex (1/4-20)	26	800-0034	4	Screw, Hex Head (5/16-18 x 2-1/4")
9	140-1198	1	Support, Air Cleaner				Begin Spec D
10	815-0377	3	Screw, Round Head (10-32 x 3/8")	27	850-0045	4	Washer, Lock - Spring (5/16)
11	518-0328	2	Clip, Cable	28	862-0015	4	Nut, Hex (5/16-18) Spec A through C
12	140-1213	1	Housing, Air Cleaner	29	520-0758	4	Stud (5/16-18 x 2-1/2")
13	140-1215	1	Gasket - Air Cleaner to Carburetor	30	154-1446	2	Gasket - Manifold to Cylinder Block
14	123-1176	1	Tube - Crankcase Breather	31	154-1468	1	Manifold, Intake
15	800-0023	2	Screw, Hex Head (1/4-20 x 1-3/8")				* - See Separate Group for Components
16	850-0040	2	Washer, Lock - Spring (1/4)				
17	145-0438	1	Gasket - Carburetor to Manifold				
18	*CARBURETOR, COMPLETE (Includes Mounting Gasket)						
	142-0587	1	Begin Spec F				
	142-0558	1	Spec A through E (For Replacement order 142-0587)				

CARBURETOR PARTS

REF.
NO.

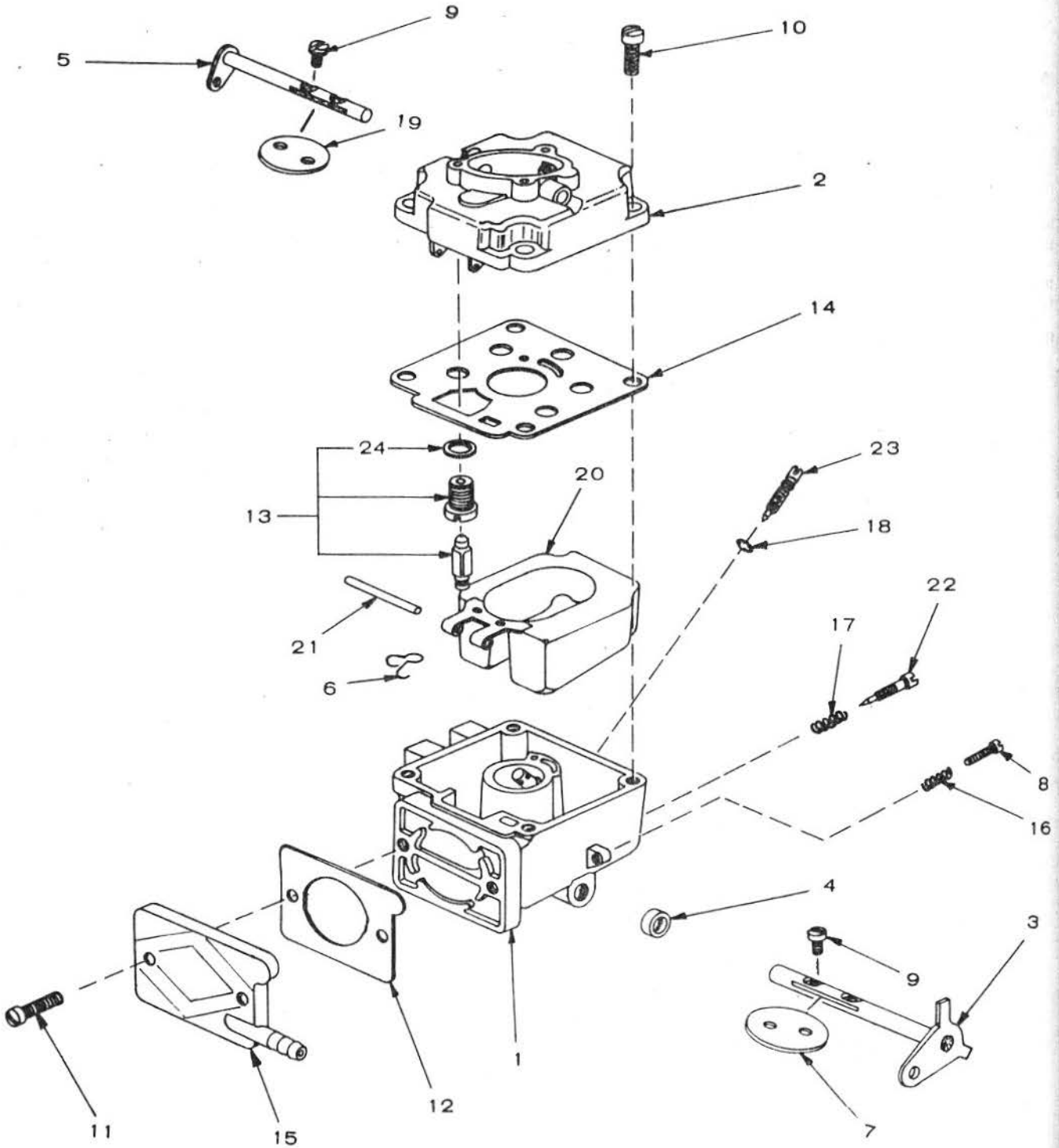

1
2
3
4
5
6
7

another free manual from www.searstractormanuals.com

CARBURETOR PARTS

REF. NO.	PART NO.	QTY. USED	PART DESCRIPTION	REF. NO.	PART NO.	QTY. USED	PART DESCRIPTION
CARBURETOR, COMPLETE (Includes Mounting Gasket)				8	142-0064	1	Screw, Throttle Stop
	142-0587	1	Begin Spec F	9	142-0334	4	†Screw, Fly to Shaft
	142-0558	1	Spec A through E (For Replacement Order 142-0587)	10	142-0539	4	Screw, Upper to Lower Body
KIT, REPAIR (Includes Parts Marked †)				11	142-0539	2	Screw, Inlet Plate
	142-0592	1	Begin Spec F	12	142-0559	1	*Gasket, Inlet Plate
	142-0561	1	Spec A through E	13	142-0553	1	†Valve Assembly, Float
KIT, GASKET (Includes Parts Marked *)				14	*GASKET, CARBURETOR BODY		
	142-0591	1	Begin Spec F		142-0572	1	Begin Spec F
	142-0560	1	Spec A through E		142-0543	1	Spec A through E
1		1	Body Lower (Not Sold Separately)	15	149-1326	1	Plate, Inlet
2	BODY, UPPER			16	142-0544	1	Spring, Throttle Stop
	142-0573	1	Begin Spec F	17	142-0282	1	†Spring, Idle Needle
	142-0533	1	Spec A through E	18	142-0550	1	*O-Ring, Packing - Power Needle
3	142-0534	1	†Shaft, Throttle	19	142-0546	1	Fly, Choke
4	142-0535	1	*O-Ring, Packing - Throttle Shaft	20	142-0547	1	Float Assembly
5	142-0536	1	Shaft, Choke	21	142-0548	1	†Shaft, Float
6	142-0554	1	Clip, Retaining - Float Valve	22	142-0016	1	†Needle, Idle
7	FLY, THROTTLE			23	142-0549	1	Needle Assembly, Power
	142-0584	1	Begin Spec F	24	142-0523	1	*Gasket, Float Valve Seat
	142-0538	1	Spec A through E				

† - Included in Repair Kit
 * - Included in Gasket Kit

FUEL PUMP PARTS GROUP

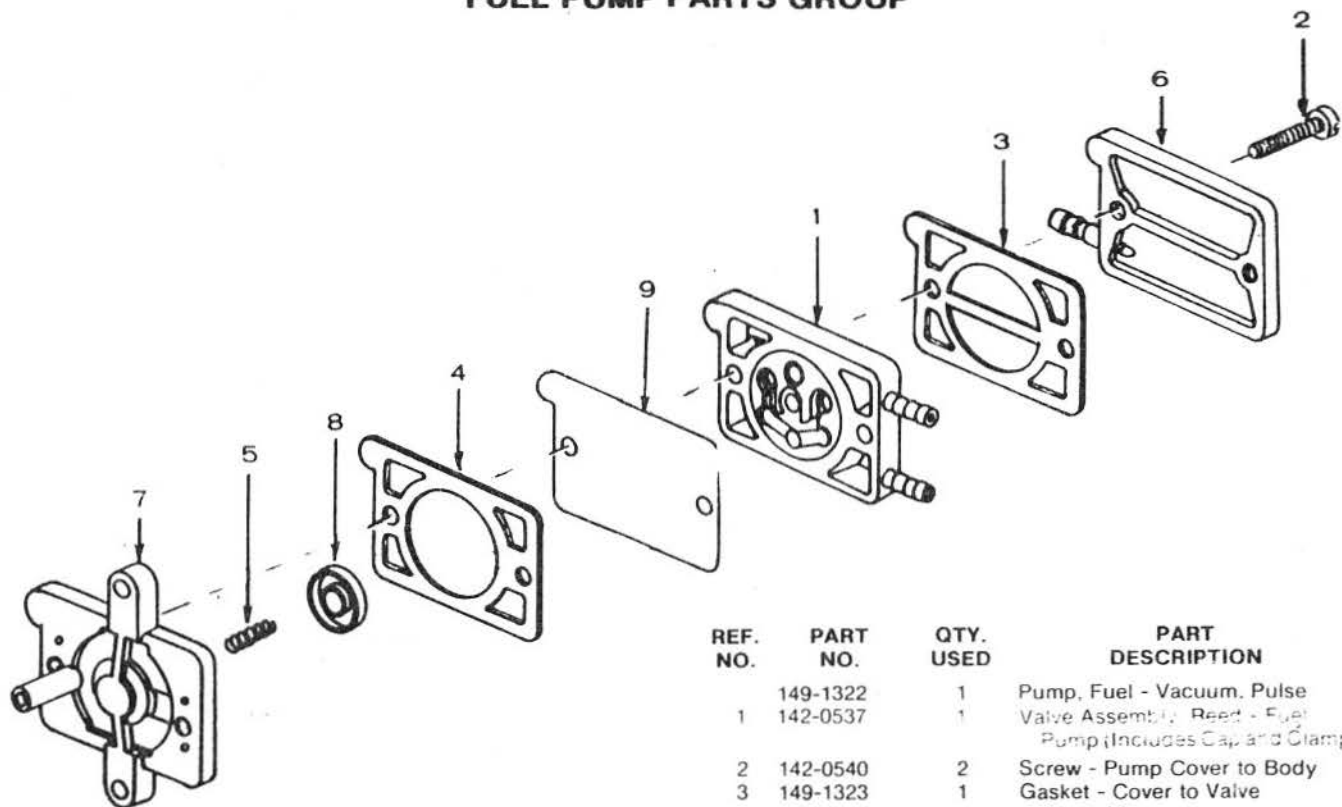

REF. NO.	PART NO.	QTY. USED	PART DESCRIPTION
	149-1322	1	Pump, Fuel - Vacuum, Pulse
1	142-0537	1	Valve Assembly, Reed - Fuel Pump (Includes Cap and Clamp)
2	142-0540	2	Screw - Pump Cover to Body
3	149-1323	1	Gasket - Cover to Valve Assembly
4	142-0541	1	Gasket - Pump Cover
5	142-0545	1	Spring - Fuel Pump
6	149-1326	1	Cover, Pump
7	149-1324	1	Base, Pump
8	142-0552	1	Plate, Drive - Fuel Pump
9	142-0555	1	Diaphragm - Fuel Pump

ALTERNATOR, AIR HOUSING, GOVERNOR AND STARTER

RE
NO

2
3
4
5
6
7
8
9
10
11
12
13
14
15
16
17
18

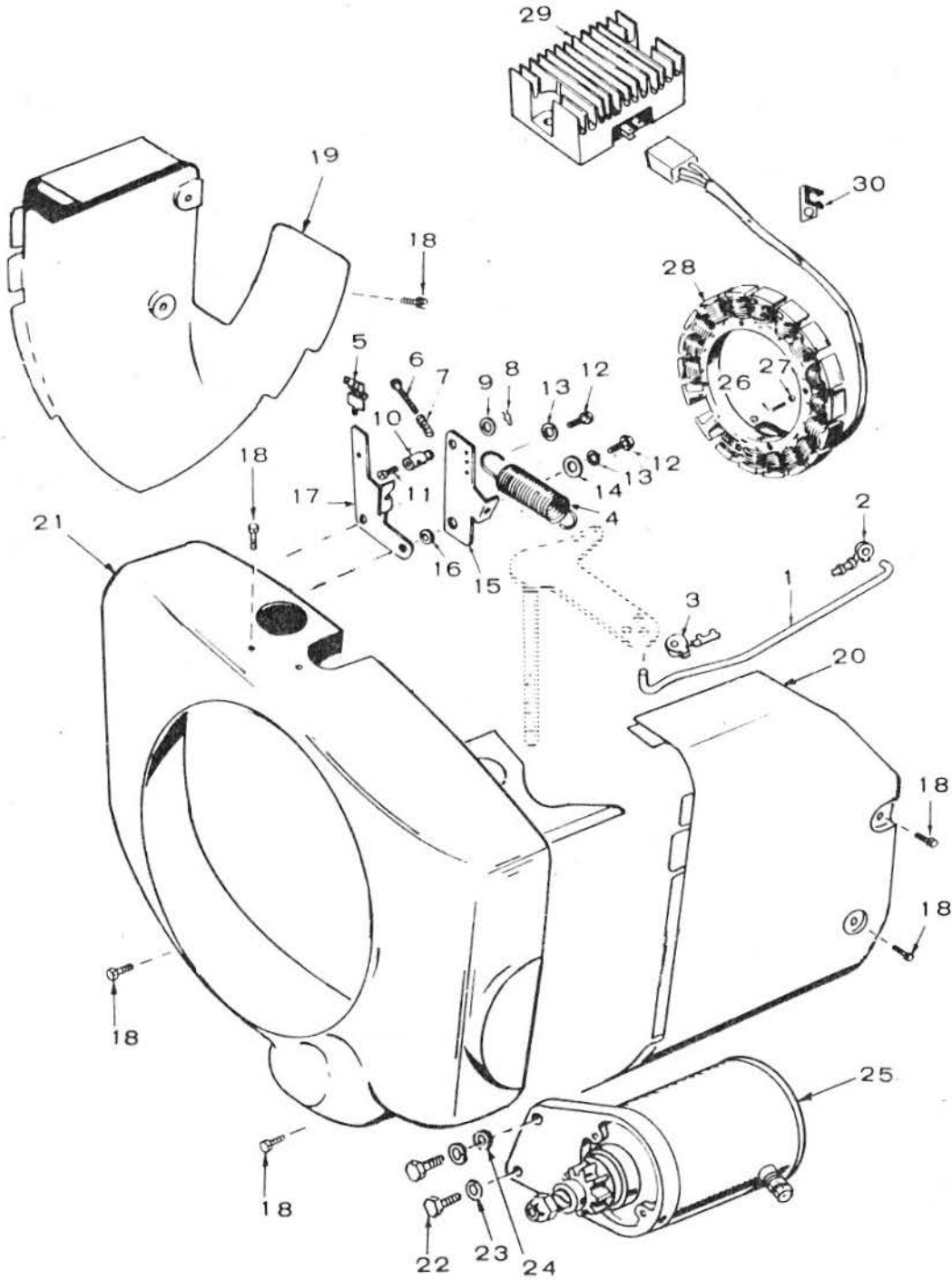

another free manual from www.searstractormanuals.com

ALTERNATOR, AIR HOUSING, GOVERNOR AND STARTER

REF. NO.	PART NO.	QTY. USED	PART DESCRIPTION	REF. NO.	PART NO.	QTY. USED	PART DESCRIPTION
1	150-1350	1	Rod, Control - Governor	19	134-2382	1	Housing, Cylinder Air - Left
2	518-0004	1	Clip, Retaining - Control Rod	20	134-2383	1	Housing, Cylinder Air - Right
3	870-0278	1	Clip, Retaining - Control Rod	21	134-2393	1	Housing, Blower
4	150-1214	1	Spring, Governor	22	800-0028	2	Screw, Hex Head (5/16-18 x 1")
5	518-0176	1	Clip, Cable - Throttle	23	850-0045	2	Washer, Lock - Spring (5/16)
6	812-0068	1	Screw, Round Head (6-32 x 1")	24	526-0113	1	Washer, Flat (5/16)
7	150-1398	1	Spring, Throttle Screw	25	MOTOR, STARTER (See Separate Group for Components)		
8	516-0059	1	Pin, Cotter		191-0933	1	Begin Spec B
9	526-0006	1	Washer, Flat (#4)		191-0883	1	Spec A (For Replacement Order 191-0933)
10	152-0155	1	Swivel, Cable - Throttle		813-0108	3	Screw, Round Head (10-32 x 1-1/2")
11	815-0104	1	Screw, Round Head (8-32 x 5/16")	26	813-0108	3	Washer, Lock - Spring (#10)
12	821-0010	2	Screw, Hex Head (1/4-20 x 1/2")	27	850-0030	3	Washer, Lock - Spring (#10)
13	850-0040	2	Washer, Lock - Spring (1/4)	28	191-0885	1	Stator, Alternator (Plugs into Regulator)
14	526-0214	1	Washer, Flat (1/4)	29	191-0886	1	Regulator, Voltage
15	150-1345	1	Arm, Governor Control	30	167-0218	1	Support, Stator Lead
16	150-1269	1	Bushing, Governor Control				
17	150-1343	1	Bracket, Governor Control				
18	815-0261	7	Screw, Hex Head (1/4-20 x 7/16")				

IGNITION SYSTEM

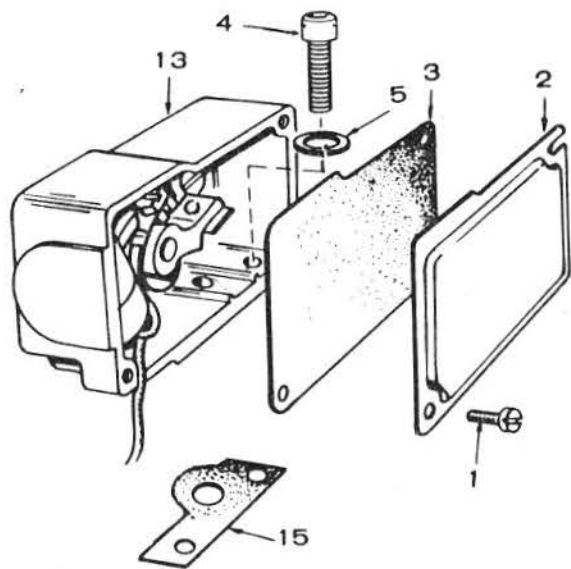

REF. NO.	PART NO.	QTY. USED	PART DESCRIPTION
	160-1161	1	Kit, Ignition Tune-Up (Includes Point Set and Condenser)
1	815-0358	2	*Screw, Pan Head (8-32 x 5/16")
2	160-1149	1	*Cover, Breaker Box
3	160-1148	1	*Gasket, Breaker Box
4	802-0034	2	*Screw, Socket Head (1/4-20 x 3/4")
5	850-0038	2	*Washer, Lock - Spring (1/4)
6	870-0221	1	*Nut, Hex (8-32)
7	815-0405	1	*Screw, Pan Head (8-32 x 1/2")
8	160-1154	1	*Point Set, Breaker
9	815-0403	1	*Screw, Pan Head (8-32 x 5/16")
10	850-0025	1	*Washer, Lock - Spring #8
11	312-0069	1	*Condenser
12	336-2132	1	Lead, Electrical
13	160-1158	1	Box Assembly, Breaker (Includes Parts Marked *)
14	160-1151	1	Plunger
15	160-1150	1	*Gasket, Mounting
16	PLUG, SPARK		
	167-0237	2	Resistor Type
	167-0241	2	Non-Resistor Type
17	503-0311	1	Clamp, Loop
18	166-0535	1	Coil, Ignition
	CABLE, SPARK PLUG		
			Resistor Type
19	167-1595	1	Spec A through F (27")
20	167-1596	1	Spec A through F (16")
			Non-Resistor Type
19	167-1593	1	Spec A through E (24")
20	167-1594	1	Spec A through E (16-3/4")
21	166-0604	2	Nut, Coil (Part of 166-0535 Coil)

* - Included in Breaker Box Assembly

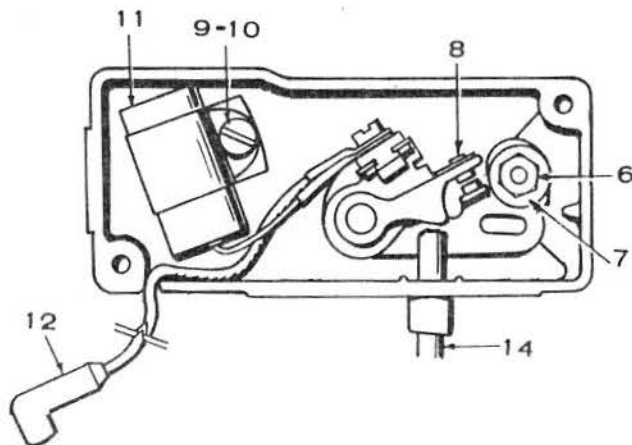
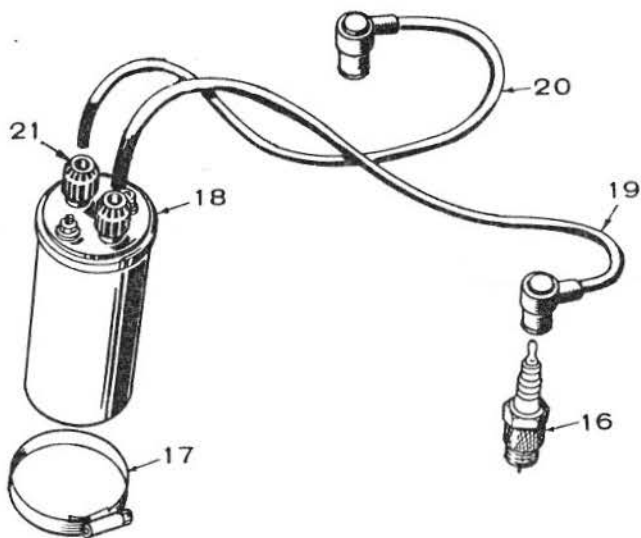

STARTER PARTS - SPEC A

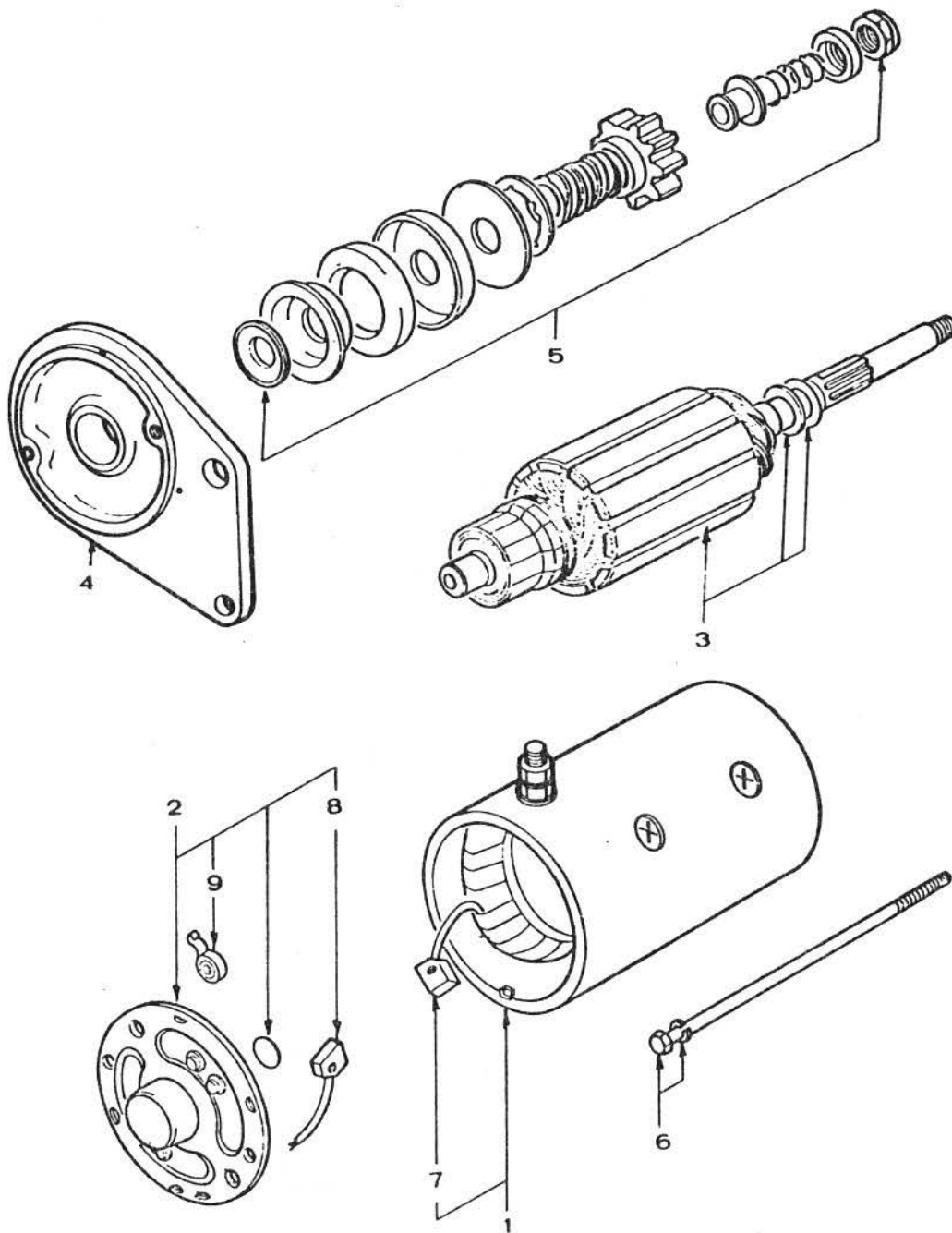

REF. NO.	PART NO.	QTY. USED	PART DESCRIPTION
	191-0883	1	Motor, Starter (For Replacement Order #191-0933)
1	191-0906	1	Housing, Starter
2	191-0907	1	End Cap Assembly
	191-0908	1	Armature, Starter
4	191-0909	1	Drive Plate Assembly
5	191-0910	1	Drive Gear Assembly
6	191-0911	2	Bolt, Through
7	191-0912	1	Brush, Field
8	191-0913	1	Brush, Ground
	191-0917	2	Spring, Brush

965-0250 (AUGUST 1977)

5 AFTER PARTS - BEGIN SPEC B

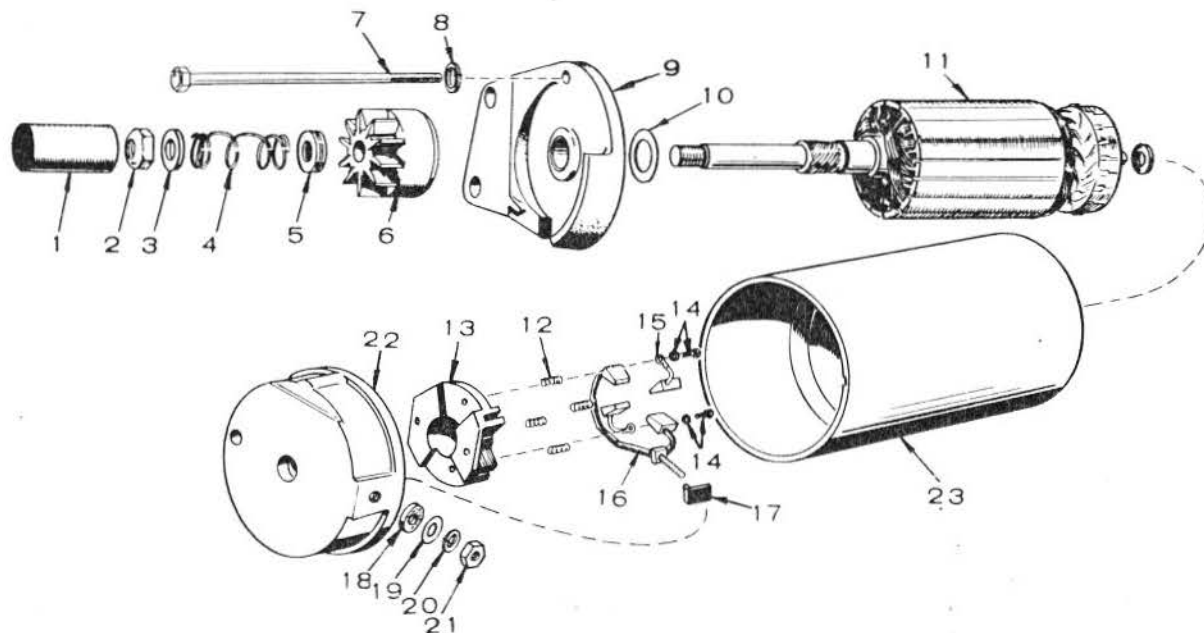

REF. NO.	PART NO.	QTY. USED	PART DESCRIPTION
1	191-0933	1	Starter
2	191-1034	1	Cover, Dust
3	191-1045	1	Nut
4	191-1046	1	Washer, Flat
5	191-1035	1	Spring, Anti-drift
6	191-1047	1	Spacer, Dust Cover
7	191-1036	1	Drive Gear Assembly
8	191-1048	2	Screw, Hex Head
9	850-0040	2	Washer, Lock - Spring (1/4)
10	191-1037	1	Drive Plate Assembly
11	191-1038	1	Washer, Thrust
12	191-1039	1	Armature, Starter
13	£	4	*†Spring, Brush
14	£	1	†Brush Holder
15	£	2	†Screw and Lockwasher
16	£	2	*†Brush, Ground

REF. NO.	PART NO.	QTY. USED	PART DESCRIPTION
16	£	1	*†Stud and Brush Assembly
17	£	2	†Insulator - Stud
18	£	1	†Washer, Insulating - Stud
19	£	1	†Washer, Flat
20	£	1	†Washer, Lock
21	£	1	†Nut, Hex
22	191-1040	1	End Cap Assembly (Includes Parts Marked †)
23	£	1	Housing, Starter
	191-1041	1	Repair Kit (Includes Parts Marked *)

£ - Not Sold Separately - Order Applicable Assembly or Kit.
 † - Included in the 191-1040 End Cap Assembly.
 * - Included in the 191-1041 Repair Kit.

SERVICE KITS AND MISCELLANEOUS

PART NO.	QTY. USED	PART DESCRIPTION
168-0123	1	Gasket Kit, Carbon Removal
168-0124	1	Gasket Kit, Engine
522-0266	1	Overhaul Kit



Onan Corporation
1400 73rd Avenue N. E.
Minneapolis, MN 55432
612-574-5000
Telex: 275477
Fax: 612-574-8087

Onan is a registered trademark of Onan Corporation