



**MASTER
SERVICE
MANUAL**

ENGINES

MINNEAPOLIS, MINNESOTA

Date: July 26,
1982

Page 1 of 1

Bulletin No. 366

Subject:

INCORRECT CAMSHAFT BEARING USAGE

Ref. File # E-72

(SERVICE)
(PARTS)

Model(s) or Series:

ANY "K" AND "B" BLOCK ENGINE SERIES AND
ALL "OCK" BLOCK WITH HIGH LIFT CAMSHAFT

Effective: IMMEDIATELY

A few parts orders were received recently for the 101-0391 camshaft bearing. This bearing should NOT be used as a replacement part. It is a semi-finished bearing used by Onan manufacturing ONLY. It must be line reamed to the correct inside diameter for the application to be usable.

The 101-0405 bearing must be used as a replacement part in above applications.

Distributors and Dealers should check your inventory and request return authorization from the Onan Parts Department for any stock on hand of the 101-0391 bearing.

There is a noticeable difference in width between the 101-0391 production bearing and the 101-0405 replacement bearing. The 101-0405 bearing is about half as wide as the 101-0391 bearing but the actual bearing surface used by the camshaft is about the same.

This difference has been questioned by Distributors many times in the past few years. This information should resolve any further questions.

The dimensional differences are illustrated and the bearings identified in the two figures below. Figure 1 is the 101-0391 production bearing which should NOT be used as a replacement part. Figure 2 is the 101-0405 replacement bearing.

5/8 INCH
WIDTH

FIGURE 1. 101-0391 PRODUCTION BEARING

1/4 INCH
WIDTH

GT-1049

FIGURE 2. 101-0405 REPLACEMENT BEARING

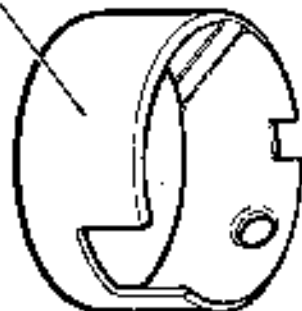
Onan**Product Support Bulletin**

Date: July 17, 1982 Page 1 of 1 Bulletin No. 365

Subject:CHANGE IN IGNITION TIMING AND
POINT GAP SETTING**Ref. File #**

E-71 (SERVICE)

Model(s) or Series:

ALL "B43C" AND "B48G" INDUSTRIAL ENGINES

Effective:

"B43C" BEGIN SPEC "B"

"B48G" BEGIN SPEC "C"

The ignition timing for above model and spec engines should be set at 16° BTDC. Setting the point gap at .016 inches will equal the desired timing specification.

ALL Operator's manuals and Service manuals for above models should be changed to reflect this new point gap/timing specification immediately.

Testing at Onan indicates improved engine reliability when timed at the 16° setting as opposed to the 20° timing originally specified for these models.



Allen C. Jacobson, Chairman
Product Support Bulletin Committee



June 28, 1978

TO: ALL U.S., CANADIAN, AND INTERNATIONAL ONAN DEALERS

SUBJECT: NEW WARRANTY COVERAGE

Effective July 1, 1978, Onan warranty will allow:

1. Travel time and mileage on marine generator sets rated at fifteen (15) kilowatts or less.
 - A. One hundred (100) miles round trip.
 - B. Two and one half (2½) hours travel time.
 - C. Full shop hourly labor rate for travel.
 - D. Mileage -- 20¢ per mile.
2. Travel time and mileage on marine generator sets rated above fifteen (15) kilowatts.
 - A. Two hundred fifty (250) miles round trip.
 - B. Six and one half (6½) hours travel time.
 - C. Full shop hourly labor rate for travel.
 - D. Mileage -- 20¢ per mile.
3. Commercial-industrial standby generator set and system installations rated at seventeen and one half (17.5) kilowatts or less.
 - A. One hundred (100) miles round trip.
 - B. Two and one half (2½) hours travel time.
 - C. Full shop hourly labor rate for travel.
 - D. Mileage -- 20¢ per mile.
4. Commercial-industrial standby generator set and system installations rated above seventeen and one half (17.5) kilowatts and load transfer switches.
 - A. Two hundred fifty (250) miles round trip.
 - B. Six and one half (6½) hours travel time.
 - C. Full shop hourly labor rate for travel.
 - D. Mileage -- 20¢ per mile.

ALL U.S., CANADIAN, AND INTERNATIONAL ONAN DEALERS
PAGE TWO

Here are copies of the new Onan Manufacturer's Limited Warranty, AB355D, dated 7-1-78, and Section 2 Page 1 and 6 of the Onan Warranty Policy Manual, PM200B, dated 7-1-78. Please add these to your Policy Manual.

If you need additional copies, please order from the Warranty Department.

ONAN
A DIVISION OF ONAN CORPORATION



Jerry McCollor
Warranty Administrator
jt

Distribution: A6A, L10A, A10A, L10A, DA10, SA10, X6A, X6A, X6L,
X6R, X6T, X6L, X6RV

2. Marine Products Applications

- a. All single and two cylinder gasoline or diesel marine electric generator sets installed below deck providing products are properly installed and operated in accordance with Onan recommendations and instructions.

LABOR TIME - Not to exceed four hours total for removal and reinstallation.

- b. All four and six cylinder gasoline or diesel marine electric generator sets installed below deck providing products are properly installed and operated in accordance with Onan recommendations and instructions.

LABOR TIME - Not to exceed eight hours total for removal and reinstallation.

3. Garden Tractor Installations

- a. Onan industrial engines used in garden tractor applications that are properly installed and operated in accordance with Onan recommendations and instructions.

LABOR TIME - Not to exceed two hours total for removal and reinstallation.

2.6 WARRANTY CLAIM SUBMITTAL TIME

Warranty claims must be received at Onan within 30 days after completion of the warranty repair. Claims received after the 30 day time limit will be denied.

2.7 REPLACEMENT PARTS WARRANTY

Onan replacement parts used when repairing equipment after the applicable warranty on that equipment has expired, and parts sold to retail customers carry a 90 day warranty.

- A. Warranty on Replacement parts covers the Onan Authorized Distributors' net cost of the replacement parts, duty, 6% allowance, and transportation cost on parts from Onan to the Onan Authorized Distributor.
1. Transportation charges for shipment of parts is limited to the standard methods of transportation; truck, rail, UPS, and parcel post.
 2. Premium transportation charges such as airfreight are to be invoiced to the customer requesting the special handling.

PM 200B

B. Replacement parts warranty does not cover:

1. Labor for installation of replacement parts.
2. Travel time and mileage.
3. Removal and installation.

C. Credit for replacement parts is obtained by submitting standard Onan Warranty Claim Form 23P015 (See sample in Section 5)

1. More than one part can be listed for a replacement parts warranty claim.
2. Standard warranty parts return policy applies. (See Section 2.4)

2.8 EXTENDED STANDBY POWER SYSTEM WARRANTY

- A. An extended warranty is offered on all 1800 RPM 60 Hertz and 1500 RPM 50 Hertz reciprocating engine driven Onan electric Standby Power Systems in commercial and industrial applications only.
- B. To qualify for an extended warranty, the installation must be a complete Onan supplied electric standby system consisting of an Onan engine generator set, automatic transfer switch, running time meter and exerciser.
- C. Warranty for standby power system installations in the United States and Canada is five (5) years or 1500 hours, whichever occurs first, from date of initial start-up.
 1. Labor is included for the first two (2) years or 1500 hours, whichever occurs first.
 2. Parts are included for five (5) years or 1500 hours whichever occurs first.
- D. Warranty for standby power system installations in countries outside the United States and Canada is two (2) years or 1500 hours, whichever occurs first, from date of initial start-up.
 1. Labor and parts are included for the full two (2) years or 1500 hours whichever occurs first.
- E. All warranty expense allowances are subject to the conditions defined in the preceding paragraph of Section 2.
- F. Registration Form 23C065 (see Section 5 for sample copy) must be completed by the Onan Distributor selling the equipment, and sent to Onan for approval.

PM 200B

SECTION 2 - WARRANTY POLICIES

2.1 WARRANTY LABOR ALLOWANCE

Manufacturer will accept warranty labor repair charges for Onan manufactured Products, based on the following conditions:

- A. Warranty repairs must be performed by an Onan Authorized Distributor or their Approved Service Dealer.
- B. Labor will be paid according to the hourly rate presently registered and approved. Request for changes must be submitted on Warranty Labor Rate Form 230018. (See Section 5)
- C. The maximum time allowed for any warranty repair job must not exceed the Onan Flat Rate Time Schedule (See Section 7), unless full written explanation is provided.
- D. Service records must be available for factory inspection, when requested.

2.2 TRAVEL TIME AND MILEAGE ALLOWANCE

- A. Travel time and mileage will be allowed in accordance with Section 2.2B, provided:
 1. Repair or replacement work is covered by warranty.
 2. Warranty failure occurs within 6 months of the effective warranty date.
 3. The equipment is permanently wired and mounted in a stationary or marine installation.
 4. Equipment has been installed, operated and serviced in accordance with factory recommendations.
 5. The warranty repairs are performed by an Onan Authorized Distributor or Approved Service Dealer.
- B. Class "A" Products. Total round trip mileage is limited to 100 miles and 2½ hours travel time.
 1. Class "A" products are rated at 17.5 kilowatts or less.
- C. Class "B" products and load transfer switches. Total round trip mileage is limited to 250 miles and 6½ hours travel time.
 1. Class "B" products have a rating above 17.5 kilowatts.
 2. Load transfer switches are models AT, LT and OT.
- D. Travel time will be paid at your registered and approved shop hourly labor rate.
- D. Mileage -- 20¢ per mile maximum.

2.3 PARTS ALLOWANCE

Onan will reimburse for genuine Onan parts required to perform repairs occurring within the warranty period, when investigation discloses the failure is covered by warranty. Warranty claims will not be accepted when other than Onan supplied parts are used on a warranty repair.

Parts allowance is based on the following:

- A. Warranty parts credit will be allowed to the Onan Authorized Distributor at their current parts cost.
- B. A six percent (6%) allowance of list price will apply to all genuine Onan parts used for warranty repair work. Distributor will reimburse their dealers for the dealer's net cost of the parts and pass on the 6% allowance.
- C. Onan allows transportation expenses for parts used on warranty repairs. Transportation allowance will be accepted only for parts shipped by standard parcel post, standard truck freight, and/or regular mail. Premium transportation charges (air, air express, special delivery, etc.) will not be accepted by Onan.

2.4 WARRANTY PARTS RETURN POLICY

Parts removed from an Onan product, when a warranty repair is performed, are to be tagged and retained by the servicing company.

- A. Onan Authorized Distributors must retain parts for 30 days, Service Dealers 45 Days, from the time the warranty claim has been submitted to Onan.
- B. When a claim is settled before the time limit (30-45 days) has expired, the parts should be scrapped.
- C. If the parts listed on your warranty claim are needed for factory inspection in order to settle a claim, a return authorization will be issued to the Authorized Onan Distributor.
- D. Two methods for return of warranty parts are used.
 1. Material Return Authorization Form 23D036 (See sample in Appendix) will be issued, listing those parts that are needed for factory inspection.



MANUFACTURER'S LIMITED WARRANTY

Onan extends to the original purchaser of goods for use, the following warranty covering goods manufactured or supplied by Onan, subject to the qualifications indicated:

THERE IS NO OTHER EXPRESS WARRANTY.

IMPLIED WARRANTIES INCLUDING MERCHANTABILITY AND FITNESS FOR A PARTICULAR PURPOSE, ARE LIMITED TO PERIODS OF WARRANTY SET FORTH BELOW AND TO THE EXTENT PERMITTED BY LAW, ANY AND ALL IMPLIED WARRANTIES ARE EXCLUDED.

IN NO EVENT IS ONAN LIABLE FOR INCIDENTAL OR CONSEQUENTIAL DAMAGES.

Note: Some states do not allow limitations on how long an implied warranty lasts, so the above limitations may not apply in every instance.

- (1) Onan warrants to original purchaser for the periods set forth below that goods manufactured or supplied by it will be free from defects in workmanship and material, provided such goods are installed, operated, and maintained in accordance with Onan's written instructions, and further provided, that installation, inspection and initial start-up on commercial/industrial generator set or power system installations are conducted by an Onan Authorized Distributor or its designated service representative.

PRODUCT APPLICATION	PERIOD OF WARRANTY
<input type="checkbox"/> Goods used in personal, family and household applications.	One (1) year from date of purchase.
<input type="checkbox"/> Goods used in commercial/industrial applications.	One (1) year from date of purchase.
<input type="checkbox"/> Commercial/industrial stationary generator sets.	One (1) year from date of initial start-up.
<input type="checkbox"/> Commercial/industrial, standby power systems with nominal operating speeds of 1800 rpm or less which are installed in the U.S. or Canada (must include Onan supplied generator set, automatic transfer switch, exerciser and running time meter).	• Five (5) years or 1500 hours, whichever occurs first from the date of initial start-up. • Labor allowance for the first two (2) years or 1500 hours, whichever occurs first from the date of initial start-up.
<input type="checkbox"/> Commercial/industrial, standby power systems with nominal operating speeds of 1800 rpm or less which are installed outside the U.S. or Canada (must include Onan supplied generator set, automatic transfer switch, exerciser and running time meter).	• Two (2) years or 1500 hours, whichever occurs first from the date of initial start-up.
<input type="checkbox"/> Repair or replacement parts	Ninety (90) days from date of purchase, excludes labor.

* Must be registered on Form No. 23C065, to be provided and completed by seller.

* Optional engine coolant heaters are warranted for one (1) year only.

- (2) Onan's sole liability and Purchaser's sole remedy for a failure of goods under this warranty and for any and all other claims arising out of the purchase and use of the goods, including negligence on the part of the manufacturer, shall be limited to the repair of the product by the repair or replacement, at Onan's option, of parts that do not conform to this warranty, provided that the product or parts are returned to Onan's factory at 1400 73rd Avenue N.E., Minneapolis, Minnesota 55432, or to an Onan Authorized Distributor or its designated service representative, transportation prepaid.

Except as indicated below, this warranty does not include travel time, mileage, or labor for removal of Onan product from its application and reinstallation.

a) Removal and Reinstallation

Onan will pay the following stated labor at straight time only for warranty work requiring removal and reinstallation of Onan Products in the following applications, provided, such warranty labor is performed by an Onan Authorized Distributor or its designated service representative:

i. Garden Tractor Applications—Up to a maximum of two (2) hours for Onan Industrial Engine installations.

ii. On-highway Recreational and Commercial Vehicle Applications—Up to a maximum of one (1) hour for Onan engineered Power Drawer® or slide-out type generator set installations.

—Up to a maximum of two (2) hours for all other permanent type generator set installations.

iii. Marine Product Installations—Up to a maximum of four (4) hours for all single and two cylinder engine powered Marine Generator Sets installed below-deck.

—Up to a maximum of eight (8) hours for all four and six cylinder engine powered Marine Generator Sets installed below-deck.

b) **Travel Time and Mileage**

- i. **Marine Generator Set Installations**—Onan will, for six (6) months after date of purchase, pay travel time up to two and one half (2½) hours and mileage cost up to one hundred (100) miles on generator sets with a kilowatt (kW) rating of fifteen (15) or less, and up to six and one half (6½) hours and mileage cost up to two hundred fifty (250) miles on generator sets with a kilowatt (kW) rating above fifteen (15) for related warranty repairs, provided, such travel and repairs are performed by an Onan Authorized Distributor or its designated service representative.
- ii. **Commercial-Industrial Standby Generator Set and System Installations**—Provided the generator set or system is permanently wired in a stationary installation, Onan will, for six (6) months after initial start-up, pay travel time up to two and one half (2½) hours and mileage cost up to one hundred (100) miles on generator sets with a kilowatt (kW) rating of seventeen and one half (17.5) or less, and up to six and one half (6½) hours and mileage cost up to two hundred fifty (250) miles on generator sets with a kilowatt (kW) rating above seventeen and one half (17.5) and for transfer switches used with industrial standby generator set and system installations, for warranty repairs performed by an Onan Authorized Distributor or its designated service representative.

(3) All claims must be brought to the attention of Onan or an Authorized Distributor or its designated service representative within thirty (30) days after discovery that goods or parts fail to meet this warranty.

(4) **THIS WARRANTY SHALL NOT APPLY TO:**

- a) Cost of maintenance, adjustments, installation and start-up.
- b) Failures due to normal wear, accident, misuse, abuse, negligence or improper installation.
- c) Products which are altered or modified in manner not authorized by manufacturer in writing.
- d) Failure of goods caused by defects in the system or application in which the goods are installed.
- e) Telephone, telegraph, teletype or other communication expenses.
- f) Living and travel expenses of persons performing service, except as specifically included in Section 2.
- g) Rental equipment used while warranty repairs are being performed.
- h) Overtime labor requested by purchaser.
- i) Starting batteries.

No person is authorized to give any other warranties or to assume any other liabilities on Onan's behalf, unless made or assumed in writing by an officer of Onan, and no person is authorized to give any warranties or assume any other liability on behalf of Seller unless made or assumed in writing by Seller.

(5) This warranty gives the user specific legal rights, and the user may also have other rights which vary from state to state.

SECTION I. GENERAL INFORMATION AND SAFETY PRECAUTIONS

INDEX

GENERAL INFORMATION

General	1-1
Interpreting Model and Spec From Nameplate on Generator Sets	1-1
Interpreting Model and Spec From Nameplate on Engines	1-1
Comments	1-1
Acknowledgments	1-1
Supplemental Information	1-2

SAFETY PRECAUTIONS

Introduction to Safety	1-3
Flammable Liquids	1-4
Fire Safety	1-6
Engine Safety	1-7
Fuel System	1-9
Exhaust System	1-10
Ignition System	1-11
Batteries	1-12
Generator Safety	1-13
Electric Shock Hazard	1-14
Transfer Switches	1-18
Marine Installation	1-19
Recreational Vehicles	1-20
Welders	1-21
Portable Generator Sets	1-23
Planned Maintenance Program	1-24
Safety Do's and Don'ts	1-25

GENERAL

This manual contains service information on the following Onan engines:

AK	CCK	NB	MJB	MDJA	MDJC
AJ	CCKA	NHA	JC	DJB	MDJF
MAJ	CCKB	NHB	MJC	MDJB	RDJC
LK	MCKK	NHC	RJC	MDJE	RDJF
LKB	NH	JB	DJA	DJC	BF

Step by step instructions for removal, disassembly, inspection, repair, assembly and installation are presented throughout the book. Most assemblies are illustrated disassembled and in many cases a glance at the illustration tells the service man all he needs to know to assemble the part.

One, two and four cylinder engines are covered in this manual. Unless specified, the repair information pertains to repair of the engines in general. Specific exceptions will be noted in the text. Use this manual in conjunction with a parts catalog whenever possible.

A dimensions and clearances section and tool catalog are provided in this manual for the convenience of its user.

The descriptions and specifications contained in this manual were in effect when the book was printed. The Onan Corporation reserves the right to change specifications or design without notice and without incurring obligation.

To ensure best results and maintain the original quality of the equipment, use only original ONAN parts.

Interpreting Model and Spec From Nameplate on Generator Sets

15.0 JC - 3CR / 96 T

1	2	3	4	5
---	---	---	---	---

1. Indicates kilowatt rating.
2. Factory code for general engine identification purposes.
3. Combines with 1 and 2 to indicate model number.
3—Indicates voltage (120/240)
C—indicates reconnectible
R—indicates remote starting
4. Factory code for specific optional equipment supplied.
5. Specification (Spec Letter). Advances with factory production modifications.

COMMENTS

We would appreciate receiving your comments, corrections and suggestions concerning this manual. Your comments will be used to correct and improve this book. Be specific—include the section and page numbers your comments pertain to. Send comments to:

ONAN CORPORATION
TECHNICAL PUBLICATIONS DEPARTMENT
1400 73rd Avenue N.E.
Minneapolis, Minnesota 55432
ATTN: MASTER SERVICE MANUAL

ACKNOWLEDGMENTS

The following companies furnished a portion of the technical information in this manual.

The Bendix Corporation, South Bend, Indiana
Champion Spark Plug Company, Toledo, Ohio
Black & Decker, Towson, Maryland
American Bosch, Springfield, Massachusetts
Sioux Valves, Albertson & Co., Inc.,
Sioux City, Iowa

Interpreting Model and Spec From Nameplate on Engines

DJC - MS / 885 T

1	2	3	4
---	---	---	---

1. Factory code for general engine identification.
2. Specific type:
S—MANUAL starting with stub shaft power takeoff.
MS—ELECTRIC starting with stub shaft, starter and generator.
MSV—VACU-FLO cooling. Same as MS, with reversed (front and duct) cooling air flow.
3. Factory code for optional equipment supplied.
4. Specification (Spec Letter). Advances with factory production modification.

SUPPLEMENTAL INFORMATION

Minor changes and additions to certain models will be added to this manual with a supplement sheet (shown below). These supplements will be added periodically with complete instructions on where to insert information.

	MASTER SERVICE MANUAL 922-0400	Date _____
SUPPLEMENTARY INFORMATION		
INSERT THIS INFORMATION IN:		
PART 1. ENGINE	SECTION	<input type="checkbox"/>
PART 2. GENERATOR	SECTION	<input type="checkbox"/>
PART 3. CONTROL	SECTION	<input type="checkbox"/>
DISPOSITION OF EXISTING SECTIONS		
REMOVE AND DISCARD		<input type="checkbox"/>
NOT APPLICABLE		<input type="checkbox"/>
NOT AFFECTED		<input type="checkbox"/>

INTRODUCTION TO SAFETY

SAFETY IS A FULL TIME ATTITUDE—SAFETY IS ALSO COMMON SENSE.

We all know what safety is, but we are usually in such a hurry that we ignore it. The man who takes chances may save himself five minutes of time, but that five minutes is unimportant when weighed against the values of personal safety, equipment damage and good workmanship.

Almost every case of personal injury or equipment damage occurs because someone ignores the fundamental rules of safety. Someone takes an unnecessary risk or is in a hurry. The highway slogan "SLOW DOWN AND LIVE" is no less true in the factory, home or office than it is on our highways.

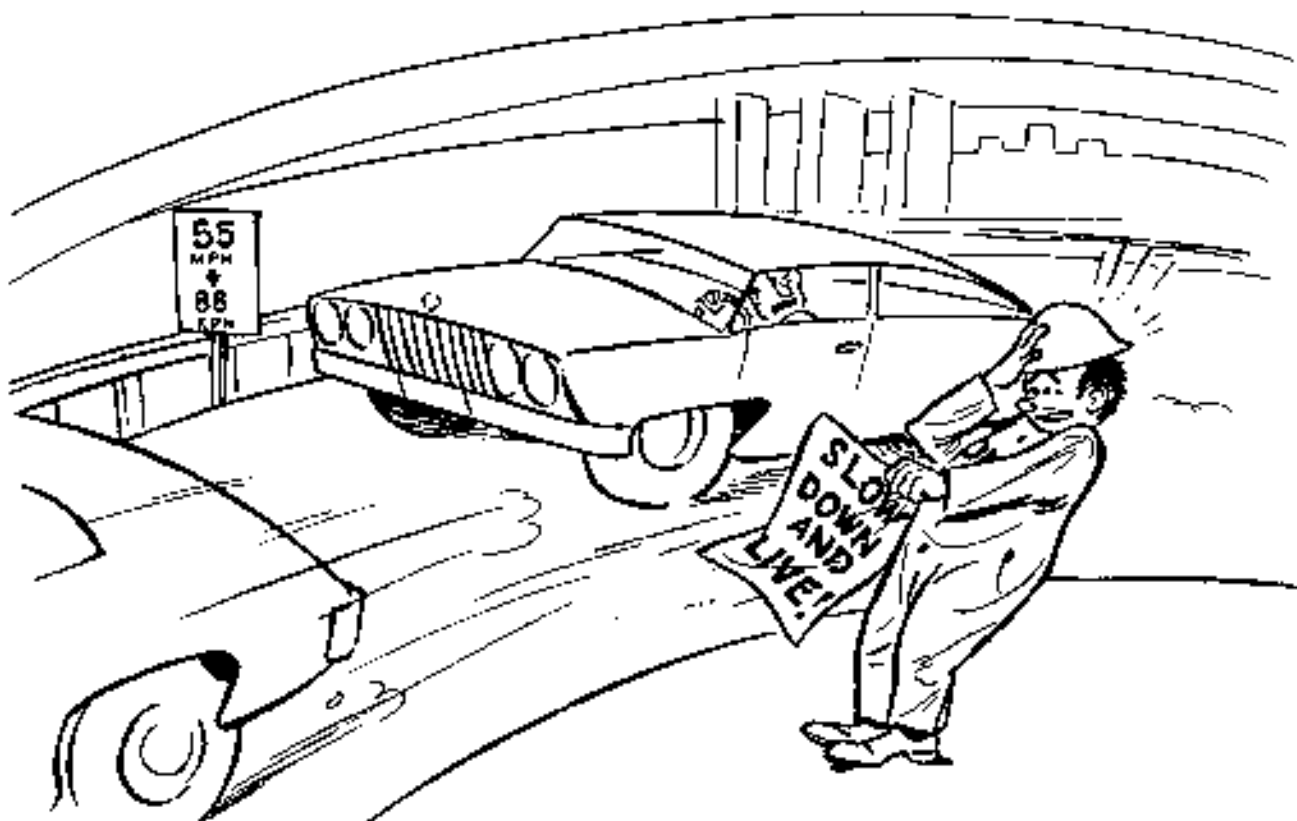

Conscientious adherence to rules of safety and a thorough planned maintenance program should provide the foundation for a working environment free from personal accidents and equipment damage.

FLAMMABLE LIQUIDS

Carelessness in handling flammable liquids is possibly the origin of most accidents associated with electric generating sets.

The ingredients of an explosion are well known. We need a combustible mixture and a means of igniting it. Internal combustion engines operate on natural gas, manufactured gas, gasoline and diesel oil fuels. Liquid fuels by themselves will not burn. This does not mean that they are safe and can be handled in a careless manner, but that they will not support combustion without being mixed with air. Fumes from liquid fuels will ignite because they have already been mixed with air. Therefore it is a good rule of thumb to remember that—

IF YOU CAN SMELL FUMES, YOU HAVE HALF THE INGREDIENTS FOR THAT EXPLOSION.

Having the combustible mixture, all that is needed now is a source of ignition. This can come from several places. Faulty engine-ignition insulation, arcing relays or brushes, welding, dropping a steel wrench on a concrete floor, or the ever present cigarette.

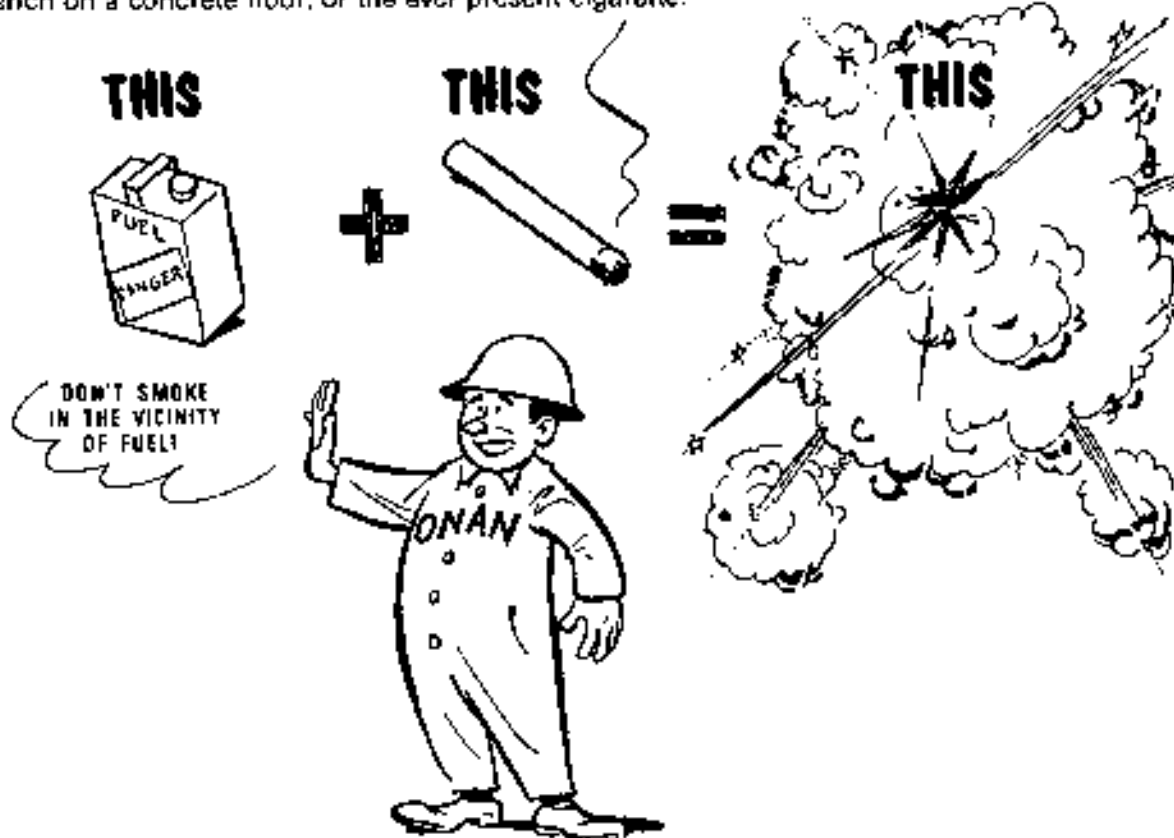

Consider the following: A loose connection in a fuel line or dirt in a solenoid valve allowing fuel vapors to escape.

Consider also an operator smoking a cigarette in the vicinity of the escaping fuel. The coal at the end of a burning cigarette has a temperature of 1000° F which goes up to 1175° (538° to 635° C) when air is pulled through it. That coal is hot enough to ignite a fuel vapor mixture.

Could the explosion have been avoided? The answer is obviously "Yes." A Planned Maintenance Program was either not in existence or not adhered to. Somebody was careless. Most accidents are caused by the failure of some individual to follow simple and fundamental safety rules or precautions.

FOR THIS REASON, MOST ACCIDENTS CAN BE PREVENTED!!

Finally, let us consider another possible source of an explosion, a battery. A panel switch is left ON, you connect the battery and as soon as the last connector touches the battery post, arcing occurs. Hydrogen gas given off from the cells ignites, again an explosion.

You now have two examples of how an explosion could be caused. Two hypothetical examples, but nevertheless they could happen. Either one of these example explosions, if real, could have injured or killed personnel and damaged equipment.



ONAN with over fifty years of accumulated knowledge in the field of electric generator set manufacture is aware that operation of these sets can be hazardous, unless safety precautions are recognized and followed.

What is safety? SAFETY is that mode of conduct which enables us to perform an operation without jeopardizing personnel or equipment.

SAFETY IS A FULL TIME ATTITUDE—SAFETY IS ALSO COMMON SENSE.

FIRE SAFETY

Fires are classified by the National Fire Protection Association (NFPA) under four headings, as follows:

- Class A. Ordinary combustibles. Paper, cloth, wood, upholstery, etc.
- Class B. Flammable Liquids. Gasoline, oil, grease, etc.
- Class C. Electrical equipment. Wiring, varnish (insulative), etc.
- Class D. Combustible Metals. Magnesium, etc.

The classes of fires most likely to be encountered during the operation of an electrical generator set are A, B, and C. Fire extinguishers rated ABC by NFPA are available, and should be provided in the immediate vicinity of the set. If possible, two extinguishers should be placed in strategic locations to the set. However, many extinguishers are available, a rigid program of service should be maintained on them to ensure that they are in perfect condition and ready for use at all times. Study the literature supplied with your extinguisher and learn how to use it. If necessary, go to your local Fire Department for instruction.

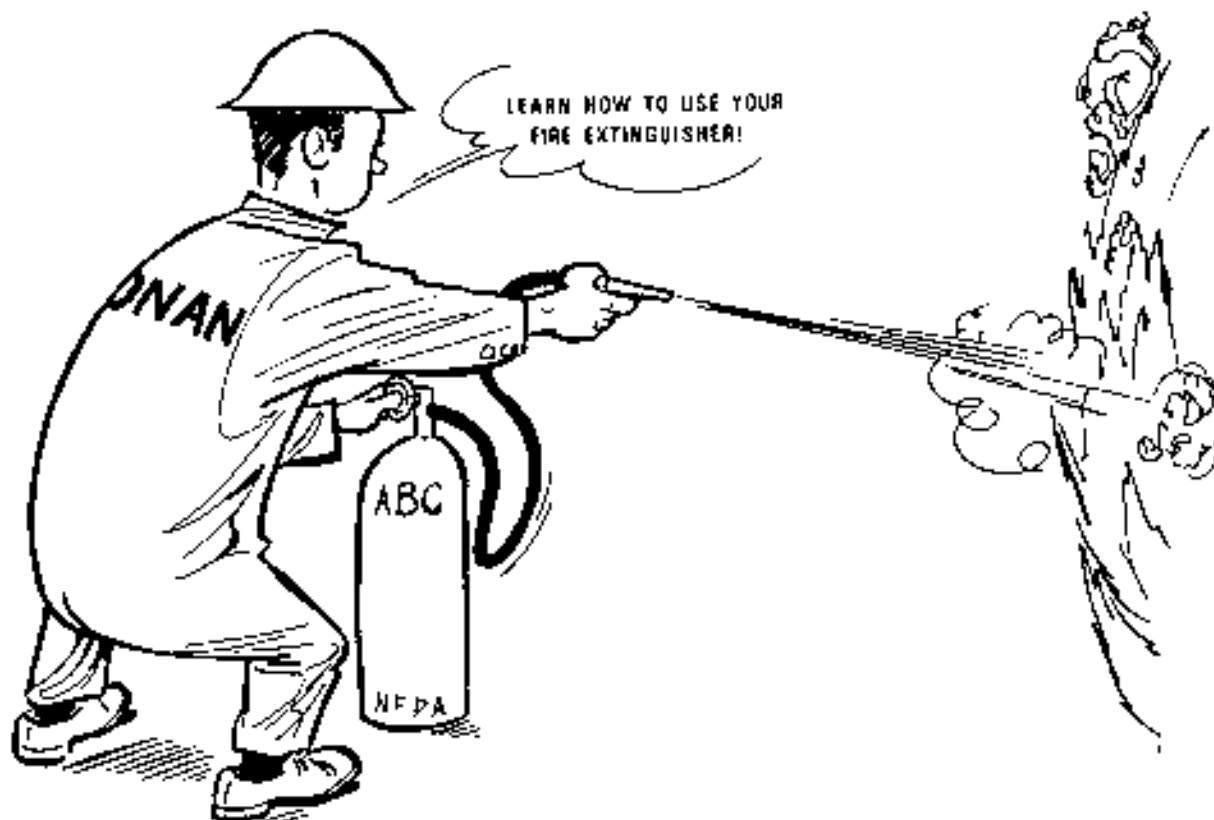

ENGINE SAFETY

INSTALLATION

A confined location for an electric generating set can mean that it is operating in an unsafe environment. Plan the installation to allow as much room as possible on all sides. This is important not only for the obvious reason of maintenance accessibility but also for purposes of adequate ventilation. If an engine does not have sufficient cooling air, the surface temperature of the cylinder block and exhaust will run hot enough to cause burns if touched, and increase fire hazard. Adequate space will allow a greater degree of cleanliness. Oil soaked rags left on the engine, oil deposits on engine or floors not only advertise a poorly maintained system, but in addition create a dangerous fire potential. Even with cooling air conforming to quantities specified, a dirty engine will run hotter than a clean one.

Good housekeeping is part of safety.

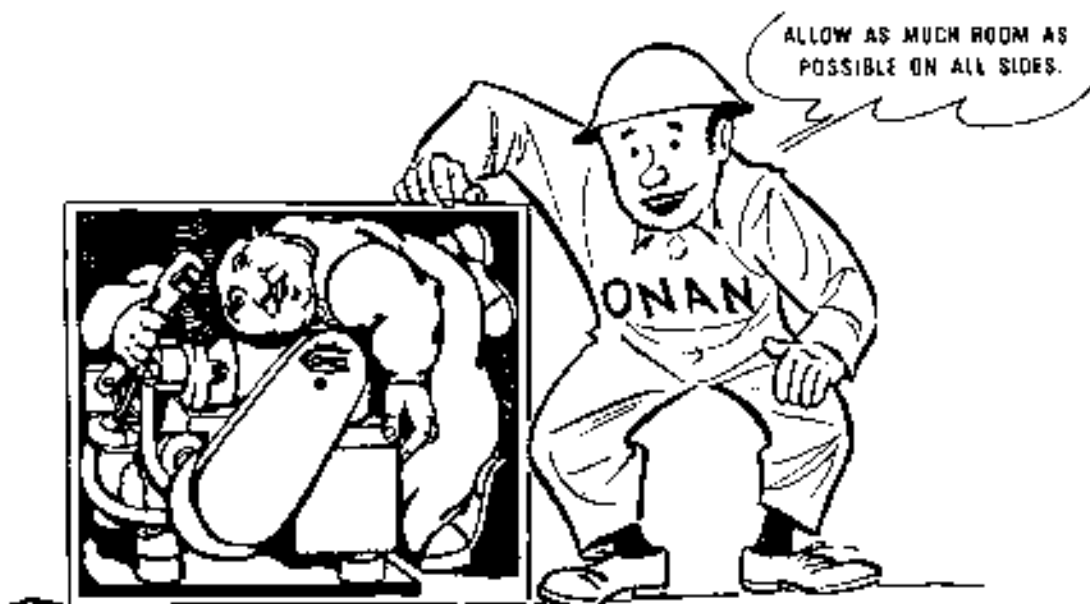

All electric generating sets should be protected. Sets installed outside a building should be protected from the elements as well as from unauthorized access. It is also your responsibility, under the law, to provide adequate protection for your set to prevent it from becoming "An attractive nuisance." Your ONAN distributor or dealer will help you to equip your installation with effectual safeguards.

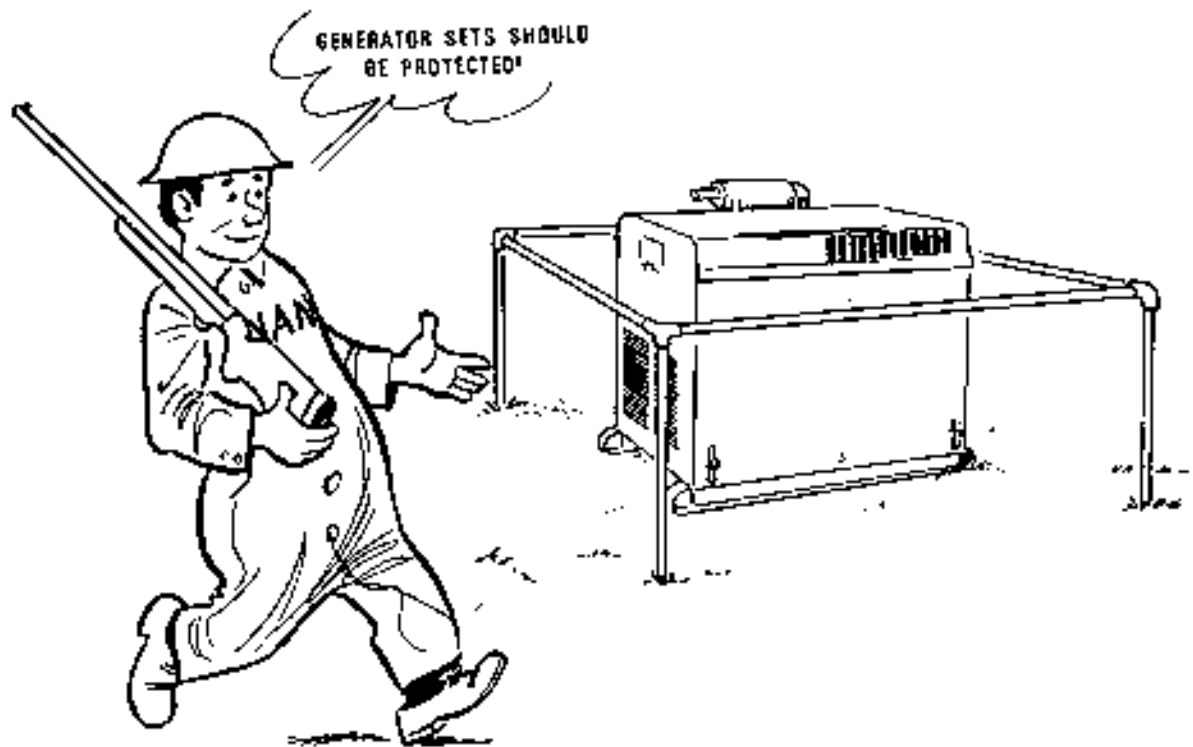

Sets installed within a building should have surrounding guard rails to prevent inadvertent contact by maintenance personnel and, if possible, should be in a room with locked doors, or steel mesh screens to prevent unauthorized access.

FUEL SYSTEM

Possibly the system requiring the greatest application of safety standards, fuel storage and supply installations also require the highest degree of maintenance. On initial installation, the tank should be located where it is not affected by earth movement (underground tanks), where such movement could cause the tank to rupture. Pipe used to transport fuel to the engine should conform to local and state code specification. It is not the purpose of this handbook to specify materials. These, particularly for fuel equipment, are governed by state and local codes together with NFPA (National Fire Protection Association) and FFMA (Fire Equipment Manufacturers Association). The actual connection to the engine should be made with flexible pipe. Use caution when selecting materials for your fuel system. Do not substitute. Keep dissimilar metals apart to eliminate electrolytic corrosion.

All fuel systems should have a positive fuel shut-off valve. Fuels under pressure (e.g., natural gas or liquefied petroleum gas) should be controlled by a positive shut-off valve, preferably automatic, in addition to any valve integral with the carburetor or gas regulator equipment. These valves should operate sharply and cleanly at all times. Dirt or grit under the valve seat will hold the valve open and allow fuel to leak through into the engine.

Gas regulators should be regularly checked to ensure that the diaphragm is not leaking. Before a fuel system is used for the first time, it should be pressurized and pressure versus time drop should be measured.

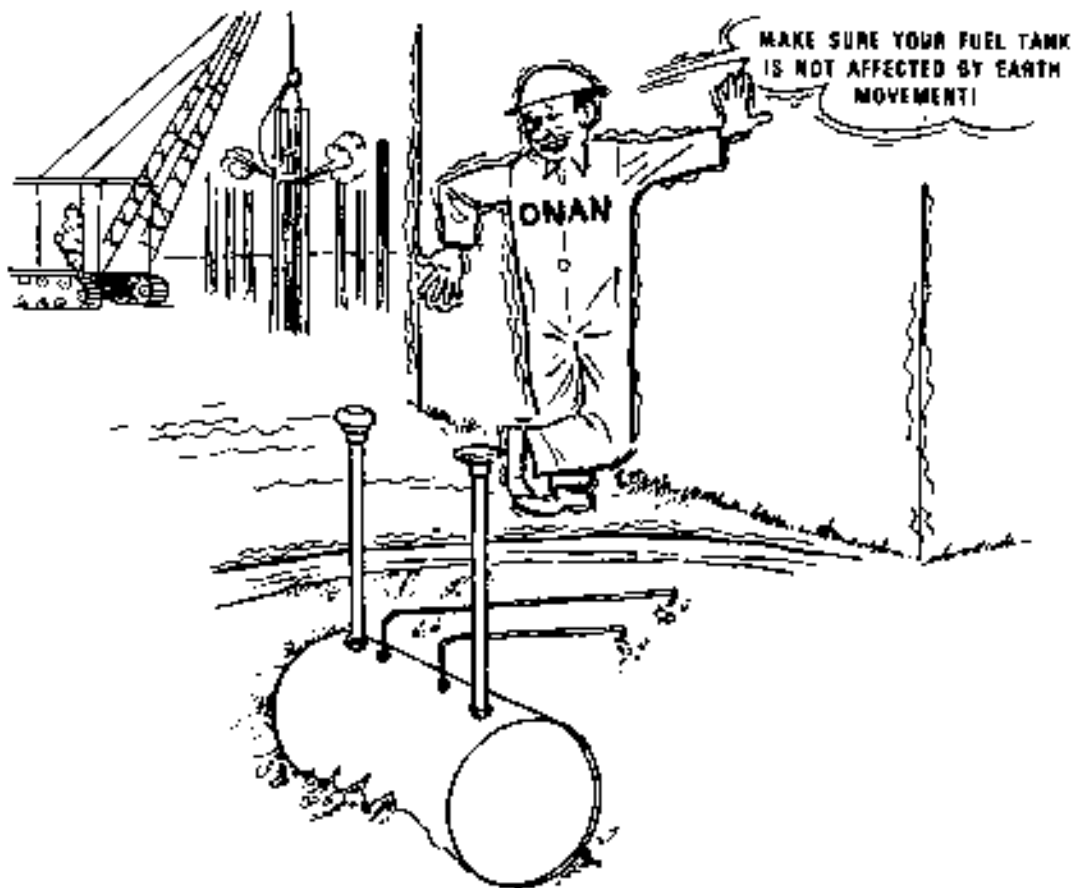

EXHAUST SYSTEM

Exhaust fumes are noxious. Inhalation can cause death.

The fumes emitted from a diesel exhaust are no less deadly than those from a gasoline exhaust.

Carbon monoxide (CO) is an odorless, colorless gas formed by incomplete combustion of hydrocarbon fuels. Design and installation of an exhaust system are very important, not only for exhaust gas evacuation, but also because the materials used are subject to very high temperatures. Complete evacuation of exhaust fumes is determined by the physical integrity of the system; ability to withstand high temperatures, by the materials used. Size of the materials used is determined by maximum allowable exhaust back pressure and length of exhaust system. In instances where an engine is exhausted through the roof of a building it is possible that an exhaust booster fan will be required to assist in exhaust gas evacuation and to keep back pressures within specified limits. The piece of pipe attached to the engine exhaust manifold connection should be flexible to compensate for thermal expansion and contraction and to absorb vibrations. This is extremely important on turbo-charged units where the stress and weight imparted to the turbo housing by a rigid piece of exhaust pipe could severely damage both the turbo-charger and the housing.

Where pipe has to be joined make sure that joint welds are leak free. When exhaust ducting is run along a combustible wall, it should be far enough from the wall to prevent heat or fire damage. Where pipe is run through a wall, a thimble should be installed which will adjust for thermal movement and also prevent heat from the exhaust damaging the wall. Sharp bends are to be avoided, but where this is not possible a condensation trap should be installed. Drain this trap frequently. Do not terminate an exhaust pipe in the vicinity of ventilating air inlet duct or venturi; exhaust gases will be pulled back into the building.

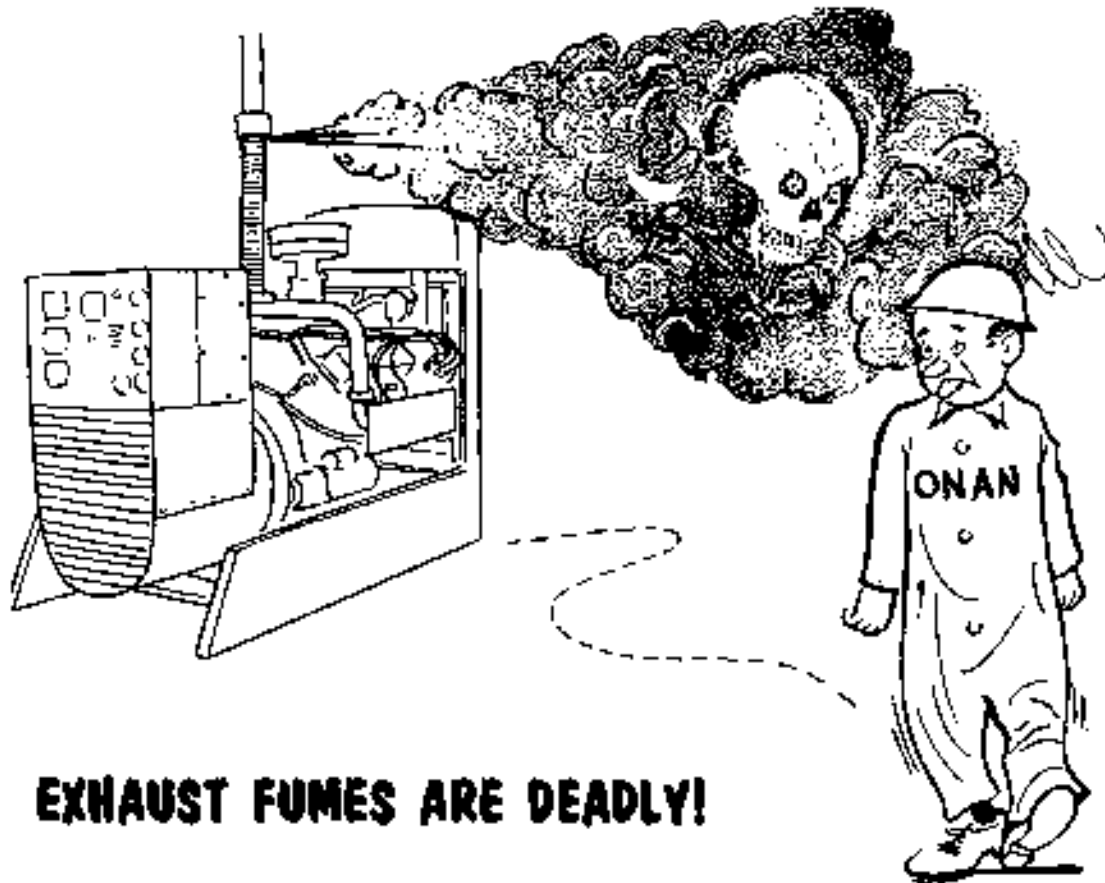

EXHAUST FUMES ARE DEADLY!

IGNITION SYSTEM

The purpose of an ignition system is to supply a spark to ignite a fuel/air mixture inside a combustion chamber. If not properly maintained and the necessary conditions exist, it can ignite a combustible mixture outside the combustion chamber. Regardless of the source of spark ignition, magneto, magnetron (low tension) or battery coil, it has to be maintained in good operating condition. Keep the system dry and clean. Periodically check the plug wires and replace any that are hard. Hard wires will crack and allow ignition current to arc across to ground thereby reducing engine power. Check distributor cap and replace if cracked; inspect internally and replace if electrodes are burned or if tracking is observed inside the cap.

Note that arcing outside the wires can cause a radiation of electrical energy which can produce interference in radio receivers. The Federal Communications Commission has minimum requirements of Electro-Magnetic Interference, and if your set does not conform to these, modifications may be necessary. ONAN generator sets do conform to these requirements and will maintain conformity to the specifications only when properly serviced.

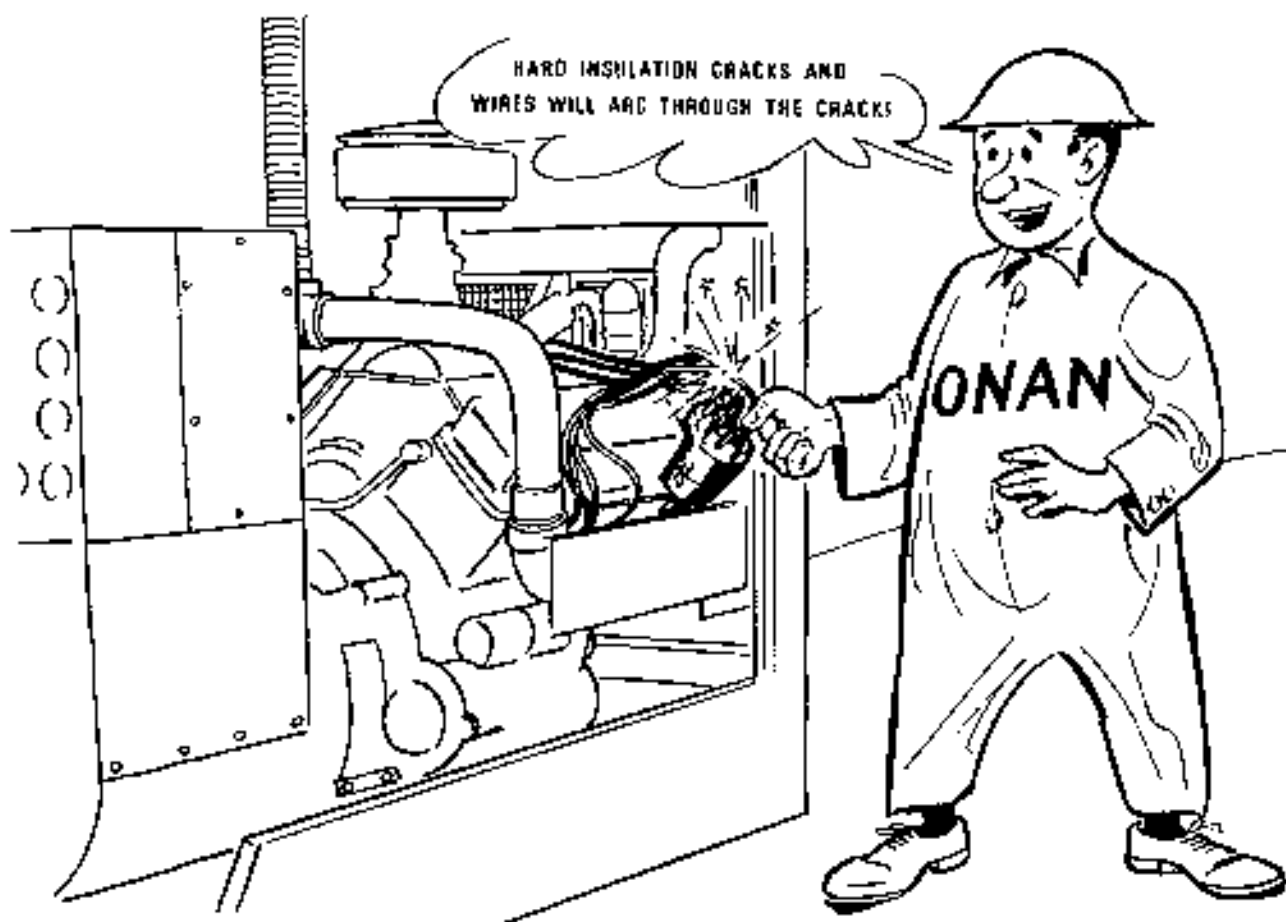

BATTERIES

FEW PEOPLE REALIZE JUST HOW DANGEROUS A BATTERY CAN BE!

The electrolyte in a lead acid battery is dilute sulphuric acid (H_2SO_4), and in an alkaline battery is potassium hydroxide (KOH). As dissimilar as these two liquids are, they have one thing in common. They give off Hydrogen gas. A battery which has a charge/discharge cycle is known as a secondary battery. During charge or discharge functions of a secondary battery a chemical change takes place within the individual cells which causes the bubbling we see through the vent hole. This bubbling is hydrogen gas and is **EXPLOSIVE**. If, during this gassing action a means of ignition is present, an explosion could occur. Added to this danger, we have to consider that, depending on the type of battery used, we have a fall-out of either sulphuric acid or potassium hydroxide caused by the explosion. Both these electrolytes are highly corrosive and dangerous.

Always wear rubber gloves, protective rubber apron and sealed eye goggles when servicing batteries. If electrolyte splashes on skin or in eyes flush immediately under running water.

When charging batteries remove the vents and allow gases to escape freely. On alkaline (e.g. Nicad) batteries, the vents are spring loaded in a closed position. Do not wedge these vents open; potassium hydroxide will weaken (i.e. specific gravity will drop) if contaminated with air. Check to see that vents are free to open with gas pressure. After the batteries are removed from the charge rack, replace vents on lead acid batteries, wash tops with baking soda and water; wash tops of alkaline batteries with vinegar and water, then rinse batteries down with water. This method of cleaning will neutralize electrolyte residues and make them safe to handle.

If full strength acid has to be broken down Always Add Acid to distilled water. If water is added to strong acid, rapid heating and bubbling will occur and the user could get splashed and burned with acid.

Potassium hydroxide electrolyte is mixed from a powder. Add the prescribed amount of powder to distilled water and stir with a glass rod. **DO NOT HANDLE WITH BARE HANDS**. The dry powder is corrosive as is the liquid electrolyte.



GENERATOR SAFETY

An electric generator set is potentially a lethal piece of equipment. A double-ended source of death or injury. One end can kill from either explosion or poison, and the other end can kill by electrocution. Yet for all these warnings, if handled with care, if treated with respect, if the fundamentals of good practice are applied, an electric generating set is one of the safest pieces of equipment to own or operate.

Before a generator set is purchased, electrical requirements should be researched and an allowance made for future additions to the system. The set should be large enough to handle immediate as well as future power requirements. Wiring and overcurrent protective devices must be adequate to carry the required circuit current without overheating.

All state and local codes applicable to your installation must be complied with. The installation must be made by a qualified licensed electrician or contractor and inspected by the appropriate local or state authority.

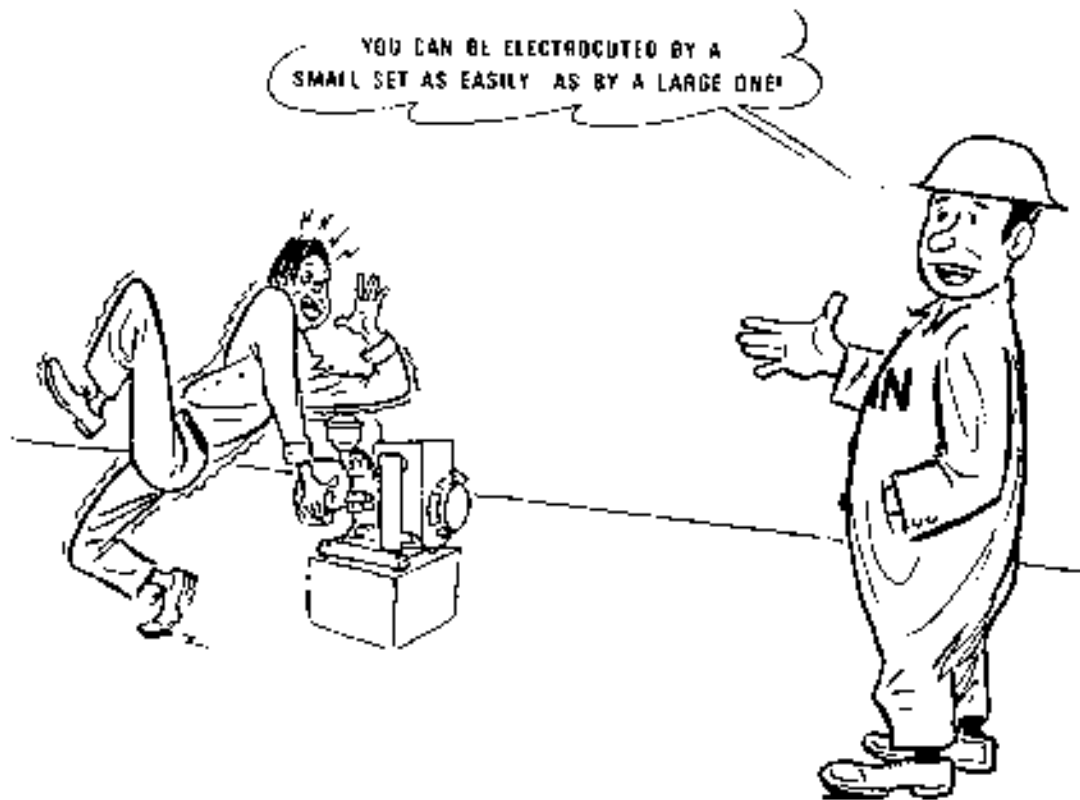

ONAN builds generators ranging in size from 1.0 KW to 600.0 KW, and in a variety of voltage ranges to 600 VAC. Regardless whether your set is the smallest or the largest, electrocution is possible.

ELECTRIC SHOCK HAZARD

It would seem that a potential of 1000 volts would be more dangerous than a potential of 100 volts. Such is not the case. A current of 10 milliamperes (1/100 amp) is capable of producing severe shock, while a current of 100 milliamperes (1/10 amp) across the heart is lethal.

Consider a hand-to-foot resistance of 500 ohms. Ohms Law tells us that the potential needed to cause a current flow of 10 milliamperes through a resistance of 500 ohms is 50 volts. A 1.0 KW single phase generator delivers 8.3 amperes at 120 VAC.

Skin resistances change through moisture and points of contact, therefore a lower skin resistance would require a lower potential to produce a current flow of 10-milliamperes.

Electric shock can produce trivial or serious injury. If the contact is poor or of short duration, a muscular contraction and a numbing sensation may be the only results. However, with good contact of a well grounded body and adequate strength and duration of current, electrocution occurs.

Low voltage (110 to 220 volts) currents are dangerous if sustained for over two seconds, in which case they frequently produce ventricular fibrillation (quivering of the heart muscles). High voltage currents are more liable to produce muscular contraction, unconsciousness, respiratory paralysis, cardiac arrest and severe burns at contact points. Electric shock from contact of the hands with a live conductor or tool may result in the victim becoming frozen in position by hand muscle spasm.



If death is not instantaneous from extremely high voltage, recovery can be effected by adequate and prompt treatment. The time lapse from the instant of shock until irreversible damage to the brain and heart is **NO MORE THAN FOUR MINUTES**. If possible, note time that shock occurred.

This means that **IMMEDIATE** action must be initiated after a person has received an electric shock.

CALL FOR HELP.

Obtain expert medical assistance if available.

The source of shock must be immediately removed by either shutting down the power or removing the victim from the source. If it is not possible to shut off power by throwing a switch, the wire should be cut with either an insulated instrument (e.g. a wooden handled axe, or cable cutters with heavy insulated handles) or a rescuer wearing insulated gloves. Whichever method is used, do not look at the wire while it is being cut. The ensuing flash can cause blindness. Remember that insulated gloves must be insulative and not just rubber gloves manufactured for protection from liquids. If the victim has to be removed from live circuitry pull him off with a non-conductive material. Use his coat, a rope, wood, or loop your belt around his leg or arm and pull him off. **DO NOT TOUCH** him or you might be shocked by the current flowing through his body. When the victim and power source have been separated, check immediately for respiration and presence of pulse. If a pulse is present, respiration can be restored by mouth-to-mouth resuscitation.



REMEMBER—YOU HAVE ONLY FOUR MINUTES and some of it has already gone!!! In the event that pulse and respiration are not present, proceed as follows: Notify the closest medical authority, fire or police department, then —

STEPS IN EXTERNAL CARDIOPULMONARY RESUSCITATION (CPR)

1 Administer one or two sharp blows to the lower half of the patient's sternum. If this does not restore the pulse and breathing and bring the pupils back to normal, go on to the next steps.

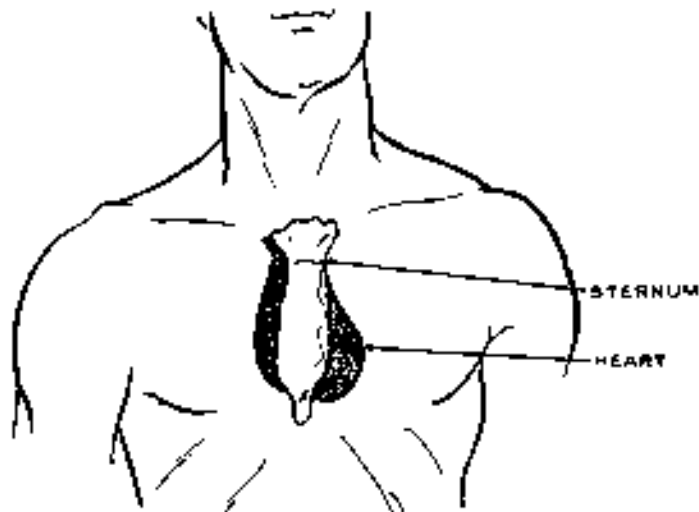

2 Kneel beside the patient's head. The patient's back should be on a hard surface (floor, breadboard, sidewalk). Place one hand under his neck and tilt the head backward to open the airway. Make sure the tongue is not obstructing the airway (obstructed in top sketch).



3 While keeping the hand under the neck for support, seal the nose by pinching it with your thumb and index finger.

4 Place your mouth firmly over the patient's mouth and inflate the lungs. (Puff lightly for an infant or small child.) Unseat the nose and remove your mouth, allowing the patient to exhale. Repeat at a rate of once every five seconds for an adult, once every two to three seconds for an infant or child.



5 After five inflations, change your position to the patient's side. Keeping your elbows stiff, place the heel of one hand on the lower half of the patient's sternum, then place the heel of the other hand on top of the first one. Depress the chest 1½ to 2 inches once each second.

6 Alternate lung inflations with chest depressions as follows: *If alone:* two inflations followed by 15 depressions. *If you have help:* one inflation by one attendant followed by five depressions by the other attendant.



7 Check the carotid pulse and the pupils at intervals, and observe for spontaneous breathing.

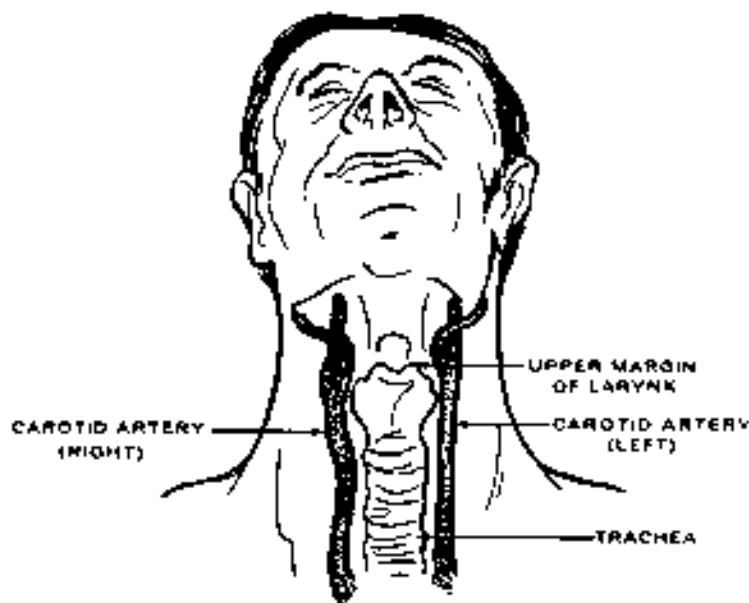

TRANSFER SWITCHES

This type of equipment, perhaps more than any other, requires an extra degree of caution and safety-awareness while open for inspection or maintenance. Although it is a normally passive unit, one side, either utilities power or generator set input, carries 120- to 600-VAC, depending on service. Even with the generator set disabled, line and load terminals are "LIVE." Refer to applicable service and maintenance instructions while working on Transfer switches.

These switches are either automatic or manual. If your unit is manual, make sure that it cannot be switched to standby while you are working on the generator. Tag the switch with a warning notice to indicate that you are working on the system, then **DISCONNECT THE BATTERIES**. If your unit is automatic, place the generator Run-Stop-Remote switch in the STOP position. In either case, **DISCONNECT THE BATTERIES!** Even if you are changing the generator set engine oil, disconnect the batteries. Serious damage to the engine will result from it being started with the crankcase drained of lubricating oil.

Before unplugging the twist-lock disconnect plug in the automatic switch cabinet, move the operation selector switch to the STOP position. Otherwise the engine will start and energize the generator side of the transfer switch.

Except for maintenance or inspection periods, the transfer switch cabinet should be locked closed and only authorized personnel should have access to the keys.

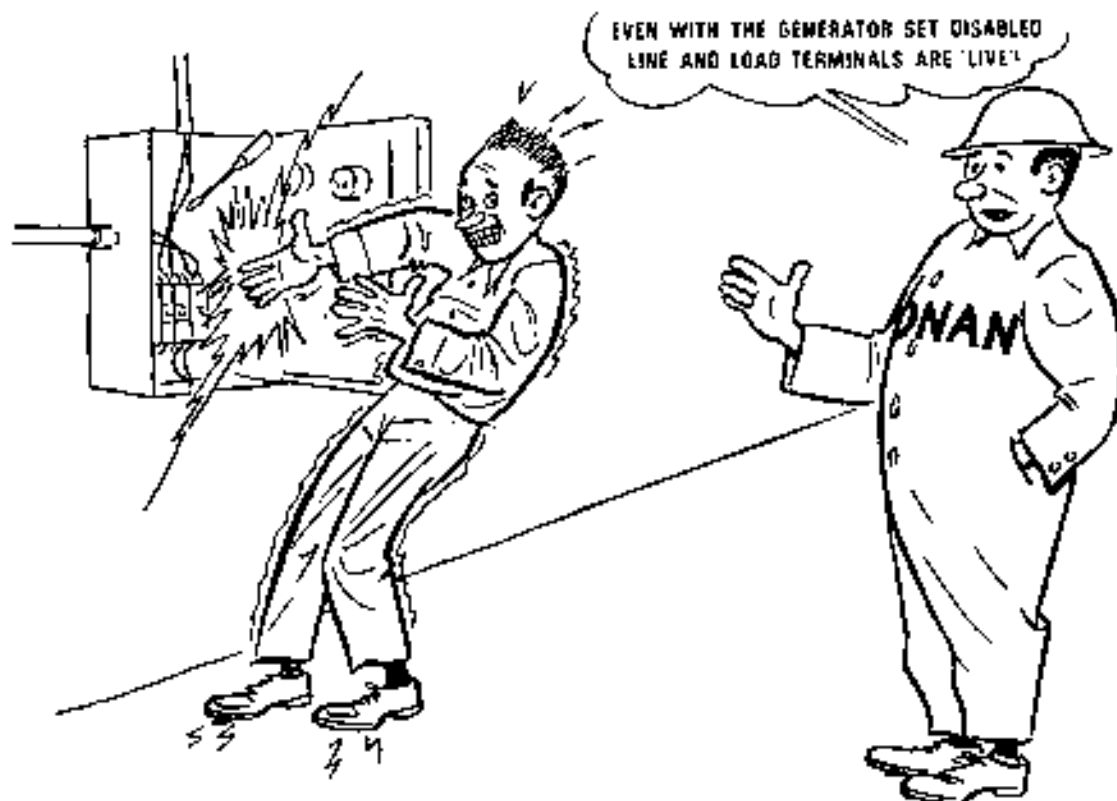

MARINE INSTALLATION

The United States Coast Guard regulations and the National Fire Protection Association are the governing authority for marine installations, therefore your generator set installation must conform to the specifications of these bodies.

It is not the purpose of this handbook to delineate specifications, but it is your responsibility to know that your installation is as the USCG and NFPA regulations stipulate.

Marine generator sets are usually located in very cramped quarters and it is because of this that the installation should be carefully engineered. The set compartment must be large enough to provide adequate access space for servicing and maintaining the set, batteries and other equipment. An engine needs combustion air and a generator needs cooling air. For example, an ONAN MCOCK—4.0 kW generator set requires 142 cubic feet (4.1 cubic meters) of air per minute for generator cooling and combustion air. Provision must be made to supply this air requirement, plus completely change the set compartment air on a continuing basis while the generating set is in operation. All flammable fumes must be purged from the compartment before the set is started. On the most perfect commutator or slip ring, brushes will arc. This arcing is sufficient to ignite unpurged fuel fumes and cause an explosion. In the event of a fire in the generator set compartment, use an extinguisher, **DO NOT USE SEA WATER**. Salt water combining with battery electrolyte forms a highly poisonous Chlorine (Cl) gas.

Adequate space around the set is important when it becomes necessary to investigate a malfunction on a hot engine. Severe burns can be received from hot exhaust systems unless properly protected.

Inspect exhaust system regularly to assure that system is free of leaks.

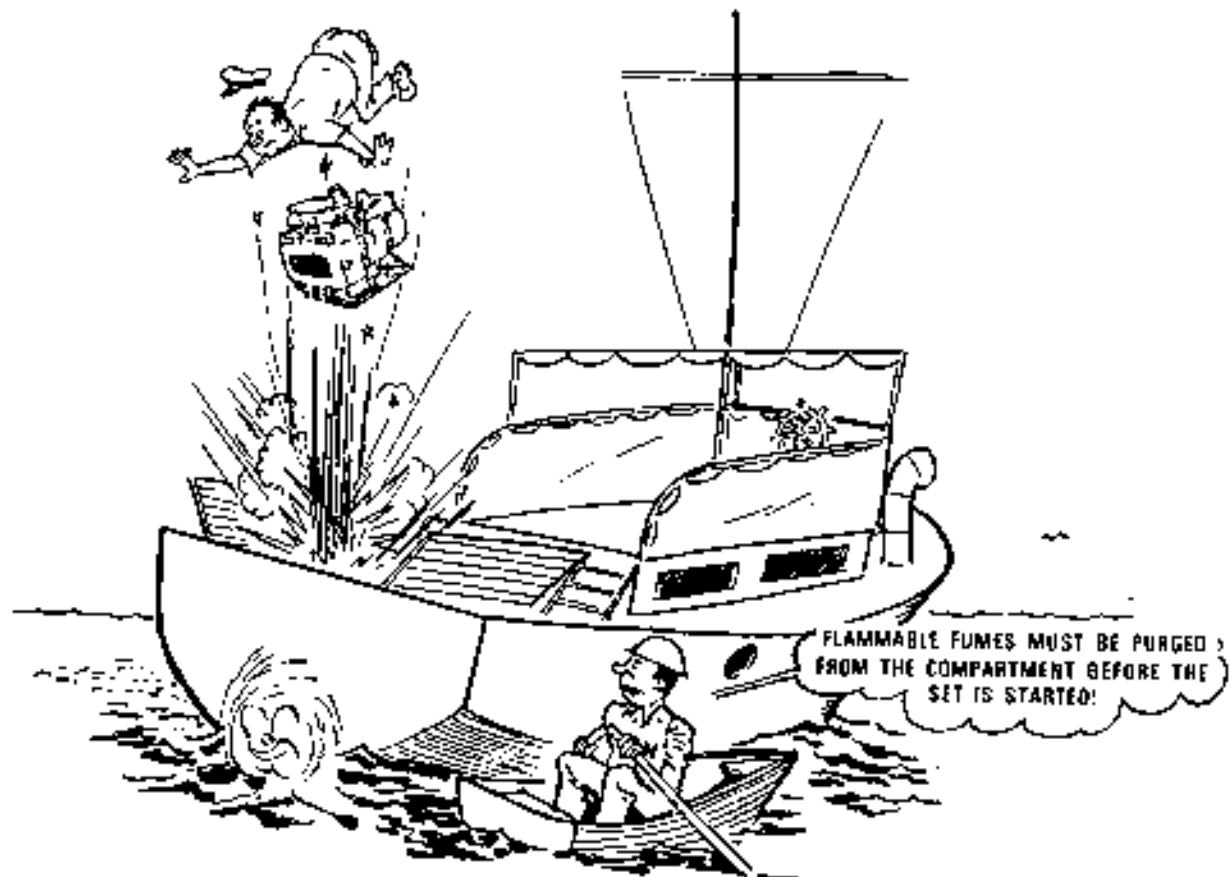

RECREATIONAL VEHICLES

The term 'Recreational Vehicles' includes camping trailers, motor homes and truck campers as defined in 'Standard for Recreational Vehicles' ANSI 119.2 and NFPA 501C. This standard, with applicable state and local codes forms the minimum requirements to which RVs must conform.

If it is not possible to return an RV to the manufacturer or dealer to install a generator set, the work should be performed by a licensed electrician and inspected by the local authority.

- Do not use flammable materials directly above or around the set compartment. Heat transferred through the sheet metal compartment structure or other material can be high enough to discolor, char or ignite fiberboard, seat cushions, etc. Use of asbestos or other non-combustible temperature insulating material in high temperature areas may be necessary.
- Separate installation area or compartment from living quarters with a vapor-tight wall to prevent entrance of noxious fumes to interior.
- Location should provide adequate compartment opening for service. Items to be serviced should be toward compartment opening.
- Base material should be oil and fuel resistant to reduce fire hazard.
- Never use discharged cooling air for heating; it could contain poisonous gases.
- Don't use insulation on the bottom of compartment unless it is fire retardant and non-absorbent to combustible materials. Oil or gasoline soaked material presents a fire hazard.
- Don't terminate exhaust under vehicle. Exhaust gases are deadly. Wherever exhaust pipe passes through a bulkhead, use an approved insulator thimble.
- Leakage of gasoline in or around the compartment is a hazard. The ventilation system should provide a constant flow of air to purge any accumulation of fuel vapor while vehicle is in transit. Compartments, for this reason, must be vapor tight to the interior.
- Do not tie electrical wiring to the fuel lines
- Seal any openings made in compartment bulkhead for conduit, wiring pipe, etc.. to keep fumes from vehicle interior.
- If necessary to install battery in set compartment, do not charge from any other source than set, when airflow through compartment will purge gases. Otherwise compartment will fill with Hydrogen gas which could ignite when engine is cranked.
- Mount battery in a separate compartment from the set, if set and vehicle share same battery.

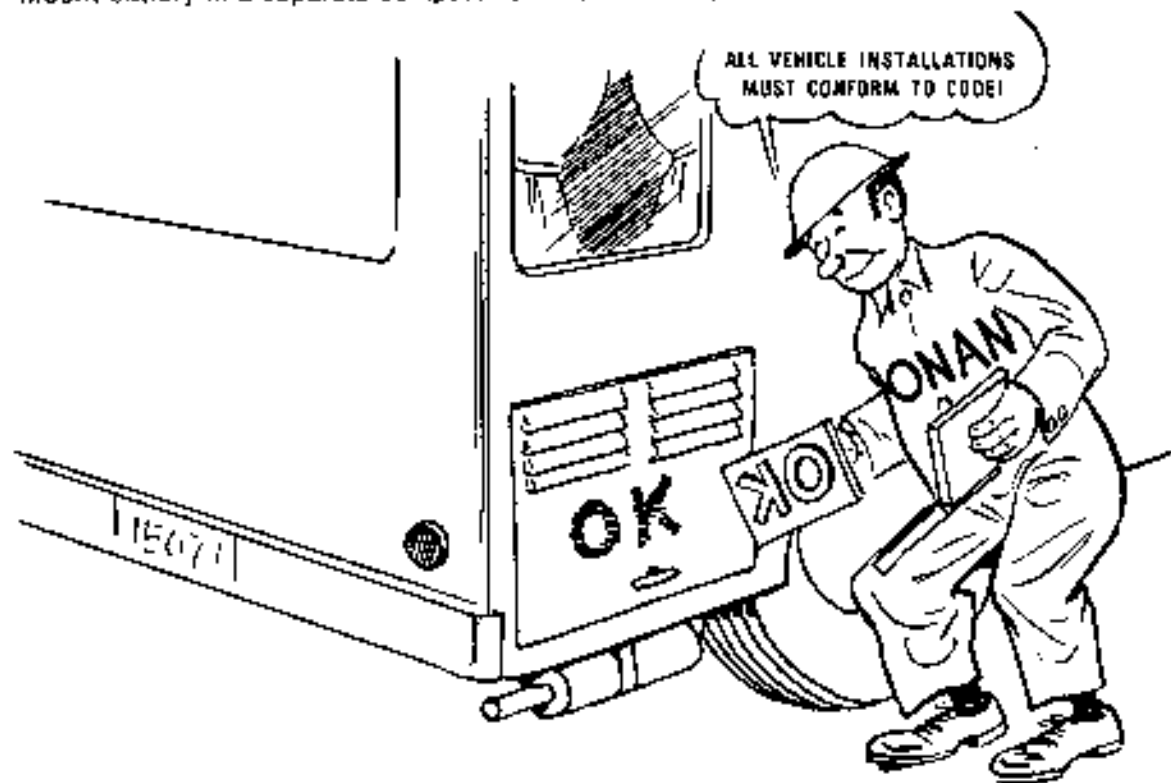

WELDERS

- **Never Wear Frayed, Flammable Or Otherwise Inadequate Clothing When Welding. Keep Clothing Dry.**

Avoid wearing light colored or open shirts that allow arc rays to penetrate and expose parts of the body to ultra-violet rays. Do not wear flammable cotton fabrics when arc welding. Wear heavy shoes, tightly laced.

To prevent severe burns from splatter and molten metal, wear leather or asbestos gloves at all times protecting hands and wrists. When welding in vertical and overhead positions, wear ear shields under helmet and leather sleevelets, apron, and leggings.

- **Use Eye Protection At All Times.**

ALWAYS wear safety goggles under the welding helmet. Keep helmet, hand shields, and face shield in good condition. Replace defective equipment.

- All arc welding produces intense ultra-violet and infra-red radiation. When welding in open areas, provide portable non-reflecting screens to protect nearby personnel from arc rays.

Do not overload cables. Do not use worn or poorly connected cables. Do not allow welding cables to contact hot metal, water, oil or grease. Prevent cables from becoming a stumbling hazard by keeping them in order and out of the way.

Use electrode holders that are completely insulated. Do not use holders with defective jaws.

Do not use the welder without grounding frame or case. Do not ground to pipelines carrying gases of flammable liquids. Be sure conductors can safely carry the grounding current.

- Keep all connections clean and tight.

Do not use an electric welder on an engine unless both the engine's battery cables and alternator wires are disconnected.

NEVER work in a damp area without suitable insulation against shock.

NEVER stand in water or on a wet floor or use wet gloves when welding.

ALWAYS dry out work pieces or bench if there is any evidence of moisture.

OPEN power circuits before inspecting machines.

ALWAYS turn off the machine when leaving the work.

- **Do Not Weld Near Flammable Materials**

NEVER weld in or near **EXPLOSIVE ATMOSPHERES.**

Clean any container that has held combustible or flammable materials by approved or prescribed methods. A very small amount of residual gas or liquid can cause a serious explosion. When the contents of the container is unknown, use an explosimeter.

Use carbon dioxide or nitrogen to ventilate a container. **NEVER USE OXYGEN.**

When the container has held a gas or liquid that readily dissolves in water, perform the following:

1. Flush container several times with water and a wetting agent (e.g., a low powered detergent). Then, fill with as much water as the work permits.
2. Provide a vent or opening in the container to allow the release of air pressure.

When container has held a gas or liquid that does not readily dissolve in water, proceed as follows:

1. Clean container with steam or a cleaning agent and purge all air with a gas such as carbon dioxide or nitrogen.
2. Use steam to clean out light material.
3. To clean out heavy grease or oil, use a strong caustic soda solution.
4. Before welding on the container, **PURGE ALL AIR** with a gas such as carbon dioxide or nitrogen.

Wear goggles and gloves when cleaning with steam or caustic soda.

Always clean container in a well ventilated area, away from any open flame.

When scraping or hammering heavy sludge or scale, use a **WET**, spark resistant tool.

Always keep head and arms as far away from the work as possible.

- **Never Weld On Hollow (Cored) Castings That Have Not Been Properly Vented.**
- **Never Pick Up Hot Metal With Bare Hands.**
- **Do Not Weld In Confined Areas Without Adequate Ventilation.**

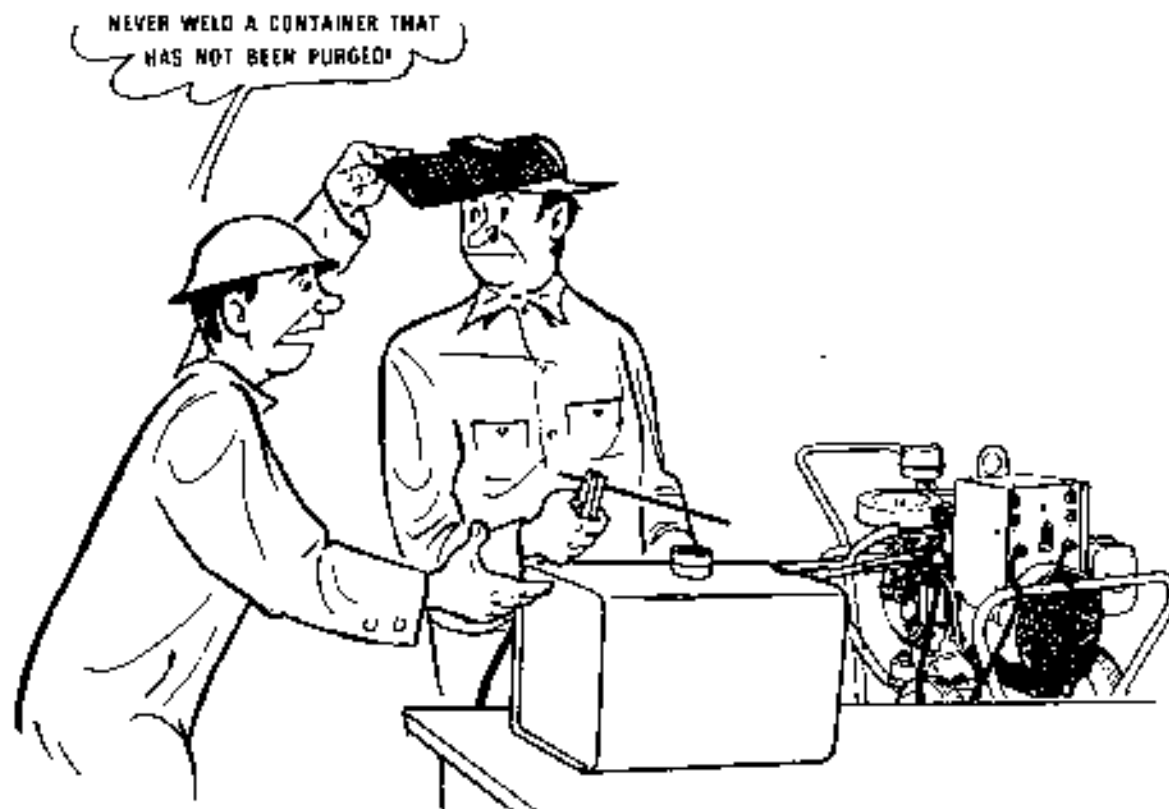

PORTABLE GENERATOR SETS

There are obviously no installation procedures to consider with a portable generator set. These units vary in size and weight, starting at about 1750 watts at 65-pounds (29.5 kg). The term 'Portable' is applied to units with a carrying frame or handle. Some units can be carried by one man, others need two or four.

If a carrying frame is too wide for comfortable carrying; if the unit is over 82-pounds (37 kg), get help to carry it. Do not attempt to carry a heavy or bulky unit without help. If at all possible, use a dolly.

When lifting, lift with your legs; keep your back straight and upright. Incorrect lifting habits can cause prolonged and painful back injury.

- When using a portable generator set, make sure that the generator frame is properly bonded to carrying frame or dolly, and that the entire set is grounded.

Units mounted on fire department equipment are so designed that they can be easily removed and used as a portable.

- If used on the vehicle, ensure that the unit is bonded to the vehicle and that the vehicle is grounded to earth.
- If used as a portable, ensure that the unit is grounded to earth.

The importance of proper bonding cannot be stressed too highly. The neutral lead of a generator is at an electrical potential **ABOVE GROUND**. Therefore, a piece of equipment with a faulty resistance leak to ground, when connected to a generator, will use a human body as a return path if an alternate (ground) is not provided.

Presence of water increases the danger and makes unit grounding more important. If a unit cannot be located in a dry spot, operators should wear electrically insulated boots and gloves. If drop lights or extension cords are in use, cover them with a trough. Loose, they present an electrical as well as a physical hazard. Carry a four foot length of copper and hammer it into the ground to provide a ground connecting point.

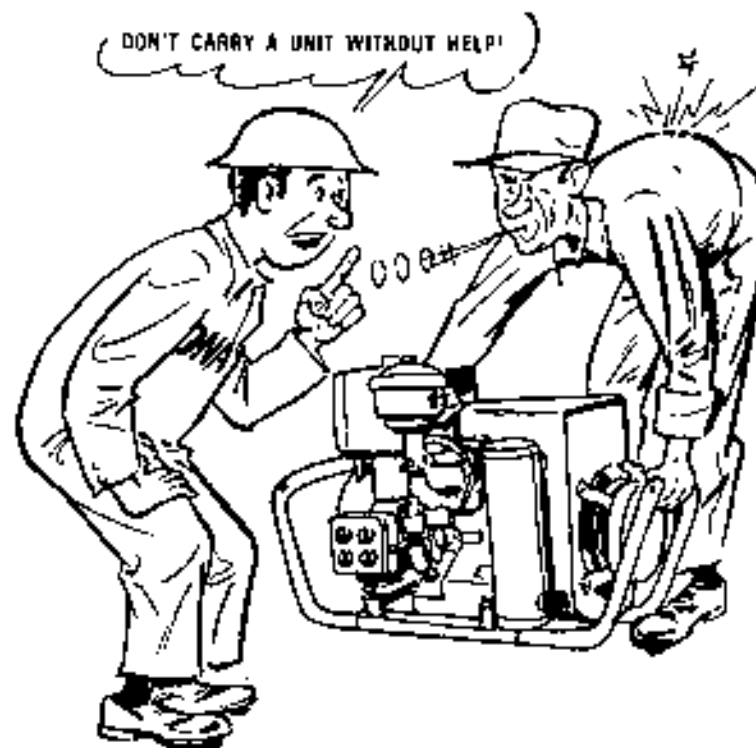

PLANNED MAINTENANCE PROGRAM

Safety and a Planned Maintenance Program (PMP) are inseparable. It can be argued that planned maintenance is a system to periodically check various parts of the equipment, so that after the complete cycle has been covered the unit is checked in its entirety. This is true. However, consider our old enemy, the explosion referred to earlier.

During your PMP you tightened all unions and connections in the fuel system. You checked all the fuel solenoid valves so that they now open and close with a clean sharp action. Ventilation fans, shafts and ducts are clean; set compartment is clean and free from gases. The major component of an explosion is now absent. Totally eliminated by your PMP.

THIS IS SAFETY!

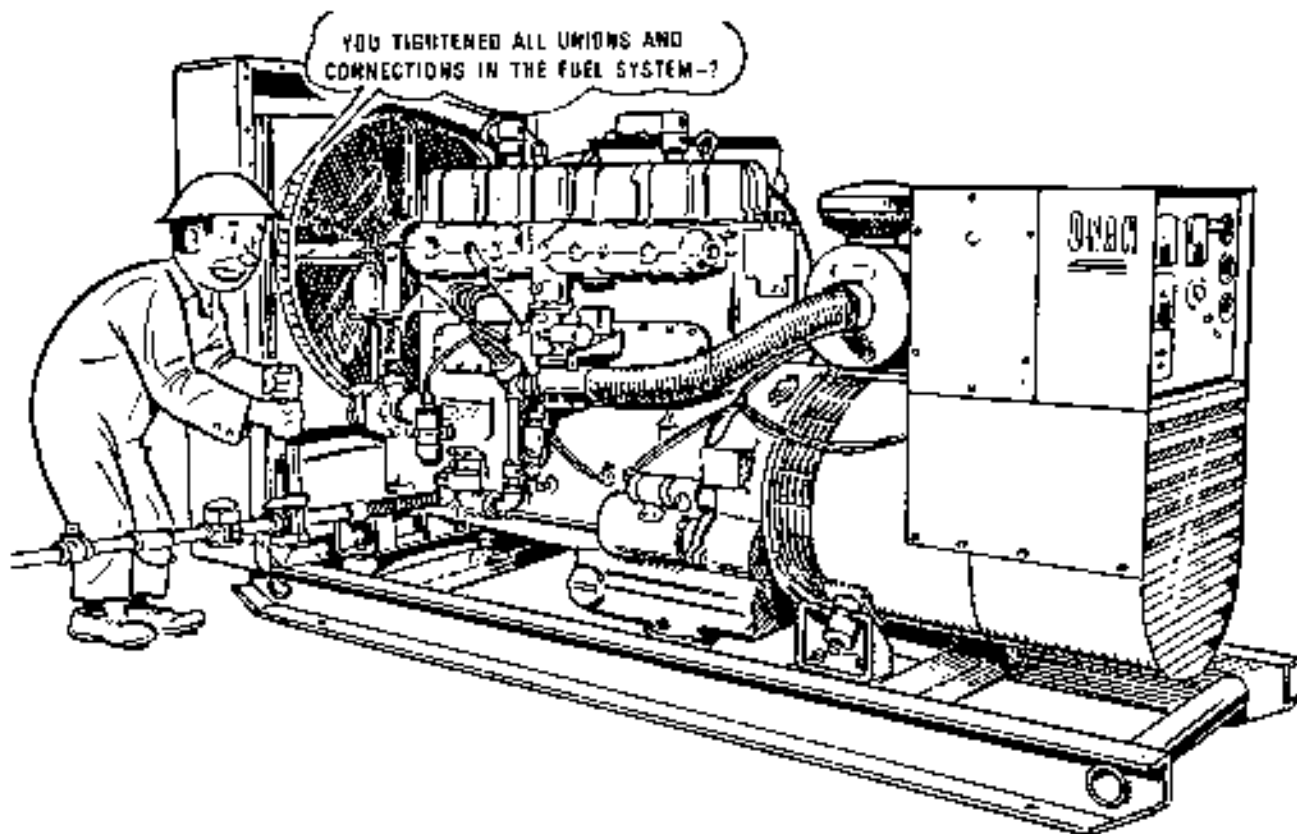

The room or compartment in which your set is located is clean and dry. No oily rags. No tools or debris on the floor. Again, your PMP has provided **SAFETY**. Your wiring system is adequately protected by correct value and quantity of circuit breakers. Where wires pass through bulkheads or sheet metal panels they are protected by grommets and cable clamps preventing chaffing.

The new circuits you recently added to the installation will not cause a fire hazard because—

- a. You knew that the power capacity of your set was such that the additional current requirement would not overload the set and cause heating.
- b. Your new circuits were installed and inspected and conform to all applicable codes.
- c. Your active PMP assures you that the installation is perfect.

THIS THEN, IS SAFETY.

SAFETY DO'S AND DON'Ts

DO—

- Perform your tasks carefully, without undue haste.
- Provide fire extinguishers (Rated ABC).
- Provide a First Aid kit (for burns and abrasions). Obtain medical attention.
- Keep your installation clean and dry.
- Use the correct tools for the job you are doing.
- Make sure that all fasteners are secure.
- Use extreme care while making adjustments on equipment while it is running.
- Keep your hands away from moving parts.
- Remember—Horse play is for horses! It has no place in a factory, an office or around machinery.
- Tag open switches.
- Disconnect batteries before starting work on generator set.
- Use screwdrivers, pliers, diagonal pliers, etc., with insulated handles.
- Remember to keep one hand (preferably the left) in your pocket if it is necessary to work on "live" circuitry. To do so will prevent passage of electricity across the heart in the event of a shock.
- Avoid excessive use of cold weather starting fluids. These can result in serious backfiring, or explosion.

DON'T—

- Leave heating devices (i.e., soldering irons) plugged in to receptacles, after you have finished with them. Should power fail, these devices could be forgotten; when power is restored, which may be after the normal workday, unattended heating equipment may overheat and start a fire.
- Allow inexperienced personnel to work on the generator or electrical equipment.
- Interfere with, or bypass interlocks.
- Remove guards or protective devices.
- Wear loose clothing or jewelry in the vicinity of moving parts. These can get in machinery, with disastrous results. Don't wear jewelry while working on electrical equipment. If your hair is long, wear a head covering. Hair caught in a drill press, fan belt or other moving parts can cause serious injury.
- Stand on a wet floor while working on electrical equipment. Use rubber insulative mats placed on dry wood platforms.
- Fill fuel tanks while engine is running, unless tanks are outside engine compartment.
- Smoke or use a naked flame in the vicinity of the generator set or fuel tanks.
- Lunge after a dropped tool. To do so may place you in a position of extreme danger.
- Work in the overhead while machinery or equipment is operating below you.
- Commence any operation until you have taken all the necessary steps to ensure that you are in complete safety.

DO PRACTICE SAFETY. THE LIFE YOU SAVE MIGHT BE YOUR OWN.

SECTION 2.

TROUBLESHOOTING CHARTS

INDEX

TABLE 2-1. GASOLINE ENGINE TROUBLESHOOTING.....	2-1
TABLE 2-2. DIESEL ENGINE TROUBLESHOOTING.....	2-2

SECTION 3.

SPECIFICATIONS

INDEX

TABLE 3-1. GENERAL ENGINE SPECIFICATIONS (GASOLINE/GAS)	3-1
TABLE 3-1. GENERAL ENGINE SPECIFICATIONS (GASOLINE/GAS)	3-2
TABLE 3-2. GENERAL ENGINE SPECIFICATIONS (DIESEL)	3-3
ADDENDUM	3-4

TABLE 3.1 GENERAL ENGINE SPECIFICATIONS — GASOLINE/GAS

DATA	AK	AJ	MAJ	LK	LKB	MB	CCK	CCMA	CCKB	MCCK
Cylinders		1	1	1	1	1	2	2	2	2
Displacement (in ³)	12.3	14.9	14.9	24.9	24.9	30.0	49.8	49.8	49.8	49.8
Displacement (L)	201.8	244.2	244.2	408.0	408.0	491.6	815.76	815.76	815.76	815.76
Bore (in)	2.50	2.75	2.75	3.25	3.25	3.582	3.25	3.25	3.25	3.25
Bore (mm)	63.50	69.85	69.85	82.55	82.55	90.49	82.55	82.55	82.55	82.55
Stroke (in)	2.50	2.50	2.50	3.00	3.00	3.00	3.00	3.00	3.00	3.00
Stroke (mm)	63.50	63.50	63.50	76.20	76.20	76.20	76.20	76.20	76.20	76.20
HP @ r/min ①	3.7 @ 36	2.75 @ 18	3.5 @ 24	5.0 @ 18	8.5 @ 18	8.5 @ 18	10.1 @ 18	16.5 @ 36	19.5 @ 36	13.5 @ 18
kW	2.78	2.06	2.69	3.73	6.34	4.85	7.61	12.31	14.55	9.7
HP @ r/min ①		5.5 @ 36	5.5 @ 36			12.0 @ 36	12.9 @ 27		20.0 @ 39	
kW		4.1	4.1			8.96	9.62		14.92	
Compression Ratio	5.5:1	6.25:1 ②	6.25:1	5.5:1	7.0:1	7.0:1	5.5:1	7.0:1	7.0:1	7.0:1
Air Requirements	240 @ 36	129 @ 18	16.0 @ 18	312 @ 18	792 @ 36	214 @ 18	577 @ 18	860 @ 36	942 @ 36	21.0 @ 18
cfm @ r/min ①	0.11 m ³ /s	0.08 m ³ /s	0.08 m ³ /s	0.16 m ³ /s	0.4 m ³ /s	0.1 m ³ /s	0.3 m ³ /s	0.41 m ³ /s	0.44 m ³ /s	0.0 m ³ /s
		240 @ 36	240 @ 36			730 @ 36	700 @ 27		1020 @ 39	
		0.11 m ³ /s	0.11 m ³ /s			0.3 m ³ /s	0.4 m ³ /s		0.48 m ³ /s	
Oil Capacity (qt/lt)	1.25	1.75 ③	1.75	2.00	2.00	2.00	4.00	3.0	4.0	4.0
(litres)	1.18	1.66	1.66	1.89	1.89	1.89	3.78	2.84	3.78	3.78
Oil Filter	NA	NA	NA	NA	NA	NA	③	③	③	NA
Starting	Manual	Manual	Remote Electric	Manual Electric	Manual Electric	Manual Electric	Manual Electric	Manual Electric	Manual Electric	Remote Electric
Ignition	Fly-Mag	Fly-Mag	Fly-Mag	Fly-Mag Ball-Coil	Fly-Mag	Fly-Mag Ball-Coil	Fly-Mag Ball-Coil	Fly-Mag	Fly-Mag Ball-Coil	Ball-Coil
Fuel	Gas	Gas	Gas	Gas	Gas	Gas	Gas	Gas	Gas	Gas

① r/min x 100

② Gas Fuel, 7.0:1

③ Option. Add 1-pint (0.47 litre) when cranking oil

④ Pressure Cooled

⑤ Vacu-Fla

⑥ Portable model capacity 1.25-qt (1.2 litre)

TABLE 3.1 GENERAL ENGINE SPECIFICATIONS — GASOLINE/GAS

DATA	GF	NH	NHA/NHB	NHC	JB	MJB	JC	MJC	RJC
Cylinders	2	2	2	2	2	2	4	4	4
Disp acmewl (in ³) (cm ³)	40.3 615.76	60.0 960.0	60.0 960.0	60.0 960.0	60.0 966.0	60.0 966.0	120.0 1.97 litre	120.0 1.97 litre	120.0 1.97 litre
Bore (in) (mm)	3.125 8.255	3.562 ¹ 90.47	3.562 90.47	3.562 90.47	3.25 82.55	3.25 82.55	3.25 82.55	3.25 82.55	3.25 82.55
Stroke (in) (mm)	2.615 66.68	3.0 76.2	3.0 76.2	3.0 76.2	3.625 92.08	3.625 92.08	3.625 92.08	3.625 92.08	3.625 92.08
HP @ r/min ¹	15 @ 36 11.94	14.0 @ 18 10.44	A. 18 @ 30 13.43	25 @ 36 18.65	15.0 @ 18 11.19	15.9 @ 18 11.46	30.5 @ 18 22.76	30.5 @ 18 22.76	33.6 @ 18 25.07
HP @ r/min ¹ kW		25 @ 36 18.65	D. 20.0 @ 33 14.92		21.5 @ 27 16.11		42.5 @ 27 31.71	42.5 @ 27 31.71	42.5 @ 27 31.71
Compressor Ratio	7.0:1	7.2:1	A. 6.5:1 B. 7.0:1	7.0:1	6.5:1	6.5:1	6.5:1	6.5:1	6.5:1
Air Requi rments cfm @ r/min ¹	792 @ 36 0.37 m ³ /s	595 @ 18 0.28 m ³ /s	A. 1160 @ 30 0.56 m ³ /s	1180 @ 36 0.56 m ³ /s	585 @ 18 0.28 m ³ /s	32.0 @ 18 0.02 m ³ /s	940 @ 18 0.44 m ³ /m	64 @ 18 0.03 m ³ /s	2012 @ 18 1.33 m ³ /s
Oil Capacity (qts) ² (litres)	2.0 1.89	4.0 ³ 3.78	3.5 3.31	3.5 3.31	3.0 2.84	3.0 2.84	6.0 5.68	6.0 5.68	6.0 5.68
Oil Filler		Yes	Yes	Yes	Yes	Yes	Yes	Yes	Yes
Starting	Electric	Manual Electric	Electric	Electric	Manual Electric	Remote Electric	Electric	Electric	Electric
Ignition	Bat-Coil	Fly-Mag Bat-Coil	Bat-Coil	Bat-Coil	Fly-Mag Bat-Coil	Bat-Coil	Bat-Coil	Bat-Coil	Bat-Coil
Fuel	Gas	Gas	Gas	Gas	Gas Gas	Gas	Gas Gas	Gas	Gas Gas

¹ r/min x 100

² Option. Add 1-pint (0.47 litre) when changing oil.

³ Add 1-pint (0.47 litre) when changing oil

⁴ Generator Set

TABLE 3.2 GENERAL ENGINE SPECIFICATIONS — DIESEL

DATA	DJA	MDJA	DJB	DJBA	MDJB	MDJE	DJC	MDJC	MDJF	RDJC	RDJF
Cylinders	1	1	2	2	2	2	4	4	4	4	4
Displacement (cu ft) (cm ³)	30.0 853.0	30.0 853.0	60.0 1706.0	60.0 1706.0	60.0 1706.0	70.0 1972 litre	120.0 3372 litre	120.0 3372 litre	140.0 3957 litre	120.0 3372 litre	140.0 3957 litre
Bore (in) (mm)	3.25 82.55	3.25 82.55	3.25 82.55	3.25 82.55	3.25 82.55	3.50 88.90	3.25 82.55	3.25 82.55	3.5 88.90	3.25 82.55	3.5 88.90
Stroke (in) (mm)	3.625 92.075	3.625 92.075	3.625 92.075	3.625 92.075	3.625 92.075	3.625 92.075	3.625 92.075	3.625 92.075	3.625 92.075	3.625 92.075	3.625 92.075
HP @ r/min ① kW	5.7 @ 18 4.25	7.0 @ 18 5.2	12.1 @ 18 9.0	14.6 @ 18 10.8	13.3 @ 18 9.9	16.5 @ 18 12.3	24.0 @ 18 17.5 27.5 @ 24 20.5	30.4 @ 18 22.7	35.3 @ 18 26.8	30.4 @ 18 22.7	32 @ 18 23.9
HP @ r/min ① kW	7.2 @ 24 5.4										
Compression Ratio	19:1	19:1	19:1	19:1	19:1	19:1	19:1	19:1	19:1	19:1	19:1
Air Requirements cfm @ r/min ①	456 @ 18 0.22 m ³ /s 581 @ 24 0.27 m ³ /s	15 @ 18 0.01 m ³ /s	622 @ 18 0.29 m ³ /s	892 @ 24 0.42 m ³ /s	32 @ 18 0.02 m ³ /s	32 @ 18 0.52 m ³ /s	840 @ 18 0.42 m ³ /s 1218 @ 24 0.58 m ³ /s	64 @ 18 0.03 m ³ /s	64 @ 18 0.03 m ³ /s	2812 @ 18 1.33 m ³ /s	2812 @ 18 1.33 m ³ /s
Oil Capacity (qts) (litres)	2.5 2.37	2.5 2.37	3.0 2.84	3.0 2.84	3.0 2.84	3.0 2.84	6.0 5.68	6.0 5.68	6.0 5.68	6.0 5.68	6.0 5.68
Oil Filter	Yes	Yes	Yes	Yes	Yes	Yes	Yes	Yes	Yes	Yes	Yes
Starting	Electric	Electric	Electric	Electric	Electric	Electric	Electric	Electric	Electric	Electric	Electric
Ignition ②	Compression	Compression	Compression	Compression	Compression	Compression	Compression	Compression	Compression	Compression	Compression
Fuel	Diesel	Diesel	Diesel	Diesel	Diesel	Diesel	Diesel	Diesel	Diesel	Diesel	Diesel

① r/min x 100

② Glow Plug Heater used for starting only

③ Add 1-quart (0.47 litre) when charging oil.

ADDENDUM TO GENERAL ENGINE SPECIFICATION

Fuel Pumps

Gasoline/Gas

Diaphragm Type: Standard All Models

Electric Type: Standard CCK (Mobile)
Standard NH (Mobile)
Optional All Models

Diesel

Fuel Transfer Pump: Standard All Models.

American Bosch Injector: Standard All Models.

Governor

Mechanical Flyball: Standard All Models

SECTION 4. DIMENSIONS, CLEARANCES, TORQUES

INDEX

TABLE 4-1. DIMENSIONS AND CLEARANCES FOR GASOLINE MODELS	4-1
TABLE 4-2. DIMENSIONS AND CLEARANCES FOR DIESEL MODELS	4-13
TABLE 4-3. OVERSIZE PART DIMENSIONS FOR GASOLINE AND DIESEL MODELS	4-21
TABLE 4-4. UNDERSIZE PART DIMENSIONS FOR GASOLINE AND DIESEL MODELS	4-22
GENERAL TORQUE INFORMATION	4-23
TABLE 4-5 TORQUE SPECIFICATIONS	4-24
FOOTNOTES	4-25

TABLE 4-1. DIMENSIONS AND CLEARANCES. SINGLE CYLINDER GASOLINE MODELS

MODEL		AK	AJ	MAJ	LK	LKB	NB
Number of Cylinders		1	1	1	1	1	1
Displacement	(in ³)	12.3	14.9	14.9	24.9	24.9	30.0
	(cm ³)	202.0	244.0	244.0	408.0	408.0	491.6
Stroke	(in)	2.503	2.503	2.503	3.00	3.00	3.00
	(mm)	63.576	63.576	63.576	76.20	76.20	76.20
Bore (Honed)	(in)	2.502	2.754	2.752	3.249	3.249	3.5635
	(in)	2.503	2.755	2.753	3.250	3.250	3.5645
	(mm)	63.551	69.952	69.901	82.525	82.525	90.513
	(mm)	63.576	69.977	69.926	82.550	82.550	90.538
Piston Diameter ⑤	(in)	2.498	2.747	2.747	3.2465	3.2420	3.5600
	(in)	2.499	2.748	2.748	3.2475	3.2430	3.5610
	(mm)	63.449	69.774	69.774	82.461	82.347	90.424
	(mm)	63.475	69.799	69.799	82.487	82.372	90.449
Measurement Taken at ①		Y	Y	Y	Y	Y	X
Clearance in Cylinder ③	(in)	0.004	0.008	0.004	0.0005	0.0005	0.0025
	(in)	0.005	0.008	0.006	0.0015	0.0015	0.0045
	(mm)	0.102	0.152	0.102	0.013	0.013	0.064
	(mm)	0.127	0.203	0.152	0.038	0.038	0.114
Ring Gap	(in)	0.006	0.006	0.006	0.010	0.010	0.013
	(in)	0.018	0.024	0.024	0.023	0.023	0.023
	(mm)	0.152	0.152	0.152	0.25	0.25	0.33
	(mm)	0.457	0.610	0.610	0.584	0.584	0.584
Piston Pin Diameter	(in)	.6250	.6250	.6250	.7500	.7500	.7500
	(in)	.6252	.6252	.6252	.7502	.7502	.7502
	(mm)	15.875	15.875	15.875	19.050	19.050	19.050
	(mm)	15.880	15.880	15.880	19.055	19.055	19.055
Piston Pin Fit in Rod	(in)	②	②	③	.0001	.0001	.0002
	(in)				.007	.0007	.0007
	(mm)				0.003	0.003	0.005
	(mm)				0.018	0.018	0.018
Piston Ring Groove Width No. 1 (Top)	(in)	.0955	.0955	.0955	.0960	.0960	.0955
	(in)	.0965	.0965	.0965	.0970	.0970	.0965
	(mm)	2.426	2.426	2.426	2.438	2.438	2.426
	(mm)	2.451	2.451	2.451	2.464	2.464	2.451
Piston Ring Groove Width No. 2	(in)	.0950	.0950	.0950	.0955	.0955	.0955
	(in)	.0960	.0960	.0960	.0965	.0965	.0965
	(mm)	2.413	2.413	2.413	2.426	2.426	2.426
	(mm)	2.438	2.438	2.438	2.451	2.451	2.451
Piston Ring Groove Width No. 3	(in)	.1565	.1565	.1565	.1880	.1880	.1880
	(in)	.1575	.1575	.1575	.1890	.1890	.1890
	(mm)	3.975	3.975	3.975	4.775	4.775	4.775
	(mm)	4.000	4.000	4.000	4.800	4.800	4.800
Piston Ring Groove Width Top 4		NA	NA	NA	NA	NA	NA
Side Clearance Top Ring	(in)	.0020	.0020	.0020	.0020	.0020	.0020
	(in)	.0080	.0080	.0080	.0080	.0080	.0080
	(mm)	0.050	0.050	0.050	0.050	0.050	0.050
	(mm)	0.203	0.203	0.203	0.203	0.203	0.203

Footnotes. See page 4-25

TABLE 4-1. DIMENSIONS AND CLEARANCES, SINGLE CYLINDER GASOLINE MODELS

MODEL		AK	AJ	MAJ	LK	LKB	NB
Valve Spring Free Length	(in) (mm)	1.600 40.64	1.600 40.64	1.600 40.64	1.662 42.22	1.662 42.22	1.662 42.22
Valve Spring Compressed Length	(in) (mm)	1.313 33.35	1.313 33.35	1.313 33.35	1.375 34.93	1.375 34.93	1.375 34.93
Valve Spring Tension Open	(lb) (N)	71-79 9.80-10.90	71-79 9.80-10.90	71-79 9.80-10.90	71-79 9.80-10.90	71-79 9.80-10.90	71-79 9.80-10.90
Valve Spring Tension Closed	(lb) (N)	38-42 5.25-5.80	38-42 5.25-5.80	38-42 5.25-5.80	38-42 5.25-5.80	38-42 5.25-5.80	38-42 5.25-5.80
Valve Seal Angle in Deg		45	45	45	45	45	45
Valve Face Angle in Deg	Exh/Int	44	44	44	44	44	44
Valve Seat Width	(in) (mm)	.031-.047 0.8-1.2	.031-.047 0.8-1.2	.031-.047 0.8-1.2	.031-.047 0.8-1.2	.031-.047 0.8-1.2	.031-.047 0.8-1.2
Valve Seat (Intake) Bore Diameter	(in) (in) (mm) (mm)	NA	NA	NA	NA	1.443 1.444 36.650 36.680	NA
Valve Seat (Exhaust) Bore Diameter	(in) (in) (mm) (mm)	1.063 1.064 27.000 27.026	1.063 1.064 27.000 27.026	1.063 1.064 27.000 27.026	1.189 1.190 30.200 30.226	1.189 1.190 30.200 30.226	1.189 1.190 30.200 30.226
Valve Seat (Intake) Diameter	(in) (in) (mm) (mm)	NA	NA	NA	NA	1.446 1.447 36.728 36.754	NA
Valve Seat (Exhaust) Diameter	(in) (in) (mm) (mm)	1.067 1.068 27.102 27.127	1.067 1.068 27.102 27.127	1.067 1.068 27.102 27.127	1.192 1.193 30.277 30.302	1.192 1.193 30.277 30.302	1.254 1.255 31.852 31.877
Valve Stem Diameter (Intake)	(in) (in) (mm) (mm)	.3090 .3100 7.850 7.874	.3080 .3085 7.823 7.836	.3080 .3085 7.823 7.836	.3425 .3430 8.700 8.712	.3425 .3430 8.700 8.712	.3425 .3430 8.700 8.712
Valve Stem Diameter (Exhaust)	(in) (in) (mm) (mm)	.3090 .3100 7.850 7.874	.3090 .3100 7.850 7.874	.3090 .3100 7.850 7.874	.3410 .3415 8.661 8.674	.3410 .3415 8.661 8.674	.3410 .3415 8.661 8.674
Valve Guide Diameter	(in) (in) (mm) (mm)	.3110 .3120 7.900 7.925	.3110 .3120 7.900 7.925	.3110 .3120 7.900 7.925	.3440 .3460 8.738 8.788	.3440 .3460 8.738 8.788	.3440 .3460 8.738 8.788
After Reaming: Intake	(in) (in) (mm) (mm)	NA	NA	NA	NA	NA	NA
After Reaming: Exhaust	(in) (in) (mm) (mm)	NA	NA	NA	NA	NA	NA

TABLE 4-1. DIMENSIONS AND CLEARANCES. SINGLE CYLINDER GASOLINE MODELS

MODEL		AK	AJ	MAJ	LK	LKB	NB
Valve Stem Clearance Intake	(in)	.0010	.0010	.0010	.0010	.0010	.0010
	(in)	.0025	.0025	.0025	.0025	.0025	.0035
	(mm)	0.025	0.025	0.025	0.025	0.025	0.025
	(mm)	0.064	0.064	0.064	0.064	0.064	0.090
Valve Stem Clearance Exhaust	(in)	.0025	.0025	.0025	.0025	.0025	.0025
	(in)	.0040	.0040	.0040	.0040	.0040	.0040
	(mm)	0.064	0.064	0.064	0.064	0.064	0.064
	(mm)	0.102	0.102	0.102	0.102	0.102	0.102
Valve Lifter Diameter ①	(in)	.7475	.7475	.7475	.7475	.7475	.7475
	(in)	.7480	.7480	.7480	.7480	.7480	.7480
	(mm)	18.987	18.987	18.987	18.987	18.987	18.987
	(mm)	19.000	19.000	19.000	19.000	19.000	19.000
Valve Lifter Bore	(in)	.7505	.7505	.7505	.7505	.7505	.7505
	(in)	.7515	.7515	.7515	.7515	.7515	.7515
	(mm)	19.063	19.063	19.063	19.063	19.063	19.063
	(mm)	19.088	19.088	19.088	19.088	19.088	19.088
Valve Clearance - Intake (Cold) ②	(in)	.0110	.0110	.0110	.0080	.0110	.0100
	(mm)	0.280	0.280	0.280	0.203	0.280	0.254
Valve Clearance - Exhaust (Cold) ②	(in)	.0110	.0110	.0110	.0160	.0110	.0140
	(mm)	0.280	0.280	0.280	0.408	0.280	0.356
Diameter Crankshaft Main Bearing	(in)	1.6857	1.6857	1.6857	1.9992	1.9992	1.9992
	(in)	1.6865	1.6865	1.6865	2.0000	2.0000	2.0000
	(mm)	42.817	42.817	42.817	50.780	50.780	50.780
	(mm)	42.837	42.837	42.837	50.800	50.800	50.800
Diameter Crankshaft Rod Journal	(in)	1.3742	1.3742	1.3742	1.6252	1.6252	1.6252
	(in)	1.3750	1.3750	1.3750	1.6260	1.6260	1.6260
	(mm)	34.905	34.905	34.905	41.280	41.280	41.280
	(mm)	34.925	34.925	34.925	41.300	41.300	41.300
Crankshaft End Play	(in)	.008	.008	.008	.006	.006	.006
	(in)	.012	.012	.012	.012	.012	.012
	(mm)	0.203	0.203	0.203	0.152	0.152	0.152
	(mm)	0.305	0.305	0.305	0.305	0.305	0.305
Main Bearing Diameter	(in)	1.688	1.688	1.688	2.0015	2.0015	2.0020
	(in)	1.690	1.690	1.690	2.0040	2.0040	2.0040
	(mm)	42.875	42.875	42.875	50.838	50.838	50.850
	(mm)	49.926	49.926	49.926	50.902	50.902	50.902
Main Bearing Clearance	(in)	.0030	.0015	.0015	.0020	.0020	.0025
	(in)	.0040	.0040	.0040	.0030	.0030	.0038
	(mm)	0.076	0.038	0.038	0.050	0.050	0.064
	(mm)	0.102	0.102	0.102	0.076	0.076	0.097
Connecting Rod Side Clearance	(in)	.012	.012	.012	.002	.002	.002
	(in)	.035	.035	.035	.016	.016	.016
	(mm)	0.305	0.305	0.305	0.051	0.051	0.051
	(mm)	0.900	0.900	0.900	0.406	0.406	0.406
Connecting Rod Bearing Clearance	(in)	.0015	.0015	.0015	.0020	.0020	.0020
	(in)	.0025	.0025	.0025	.0030	.0030	.0030
	(mm)	0.038	0.038	0.038	0.051	0.051	0.051
	(mm)	0.064	0.064	0.064	0.076	0.076	0.076
Camshaft Bearing Clearance	(in)	.0015	.0015	.0015	.0015	.0015	.0015
	(in)	.0030	.0030	.0030	.0030	.0030	.0030
	(mm)	0.038	0.038	0.038	0.038	0.038	0.038
	(mm)	0.076	0.076	0.076	0.076	0.076	0.076

Footnotes. See page 4-25

 Rev
7-75

TABLE 4-1. DIMENSIONS AND CLEARANCES. SINGLE CYLINDER GASOLINE MODELS

MODEL		AK	AJ	MAJ	LK	LKB	NB
Camshaft End Play	(in)	.003	.003	.003	.003	.003	.003
	(mm)	0.076	0.076	0.076	0.076	0.076	0.076
Camshaft Lift	(in)	.243	.243	.243	.243	.243	.300
	(mm)	6.172	6.172	6.172	6.172	6.172	7.620
Camshaft Bearing Diameter 1	(in)	1.3760	1.3760	1.3760	1.3760	1.3760	1.3760
	(in)	1.3770	1.3770	1.3770	1.3770	1.3770	1.3770
	(mm)	34.950	34.950	34.950	34.950	34.950	34.950
	(mm)	34.976	34.976	34.976	34.976	34.976	34.976
Camshaft Bearing Diameter 2	(in)	1.3760	1.3760	1.3760	1.3760	1.3760	1.3760
	(in)	1.3770	1.3770	1.3770	1.3770	1.3770	1.3770
	(mm)	34.950	34.950	34.950	34.950	34.950	34.950
	(mm)	34.976	34.976	34.976	34.976	34.976	34.976
Camshaft Bearing Diameter 3	(in)	NA	NA	NA	NA	NA	NA
	(in)	NA	NA	NA	NA	NA	NA
	(mm)	NA	NA	NA	NA	NA	NA
	(mm)	NA	NA	NA	NA	NA	NA
Camshaft Journal Diameter 1	(in)	1.3740	1.3740	1.3740	1.3740	1.3740	1.3740
	(in)	1.3745	1.3745	1.3745	1.3745	1.3745	1.3745
	(mm)	34.900	34.900	34.900	34.900	34.900	34.900
	(mm)	34.912	34.912	34.912	34.912	34.912	34.912
Camshaft Journal Diameter 2	(in)	1.3740	1.3740	1.3740	1.3740	1.3740	1.3740
	(in)	1.3745	1.3745	1.3745	1.3745	1.3745	1.3745
	(mm)	34.900	34.900	34.900	34.900	34.900	34.900
	(mm)	34.912	34.912	34.912	34.912	34.912	34.912
Camshaft Journal Diameter 3	(in)	NA	NA	NA	NA	NA	NA
	(mm)	NA	NA	NA	NA	NA	NA
	(in)	NA	NA	NA	NA	NA	NA
	(mm)	NA	NA	NA	NA	NA	NA
Ignition Point Gap	(in)	.022	.022	.020	.020	.020	.020
	(mm)	0.56	0.56	0.51	0.51	0.51	0.51
Spark Plug Gap (Gasoline)	(in)	0.025	0.025	0.025	0.025	0.025	0.025
	(mm)	0.64	0.64	0.64	0.64	0.64	0.64
Spark Plug Gap (Gas)	(in)	.018	.018	.018	.018	.018	.018
	(mm)	0.46	0.46	0.46	0.46	0.46	0.46
Ignition Timing: Gasoline Deg. BTC (Running)		19-1800	19-1800	19-1800	19	24	22
		25-3600	25-3600	25-3600			
Ignition Timing: Gas Deg. BTC (Running)		19-1800	19-1800	19-1800	19	24	22
		25-3600	25-3600	25-3600			
Injection Pump Timing		NA	NA	NA	NA	NA	NA
Nozzle Opening	(PSI) (N _m)	NA	NA	NA	NA	NA	NA
Compression (Sea Level)	(PSI)	95-105	95-105	95-105	100-120	100-120	105-115
	(kPa)	655.5-724.0	655.5-724.0	655.5-724.0	689-827	689-827	724.0-793.0
Flicker Point Gap	(in)	.020	.020	.020	NA	NA	NA
	(mm)	0.51	0.51	0.51	0.51		
Start Disconnect	(in) (mm)	NA	NA	NA	NA	NA	NA

TABLE 4-1. DIMENSIONS AND CLEARANCES. TWO CYLINDER GASOLINE MODELS

MODEL		BF	CCK MCKK	CCKA CCKB	NH	NHA, NHB, NHC	JB MJB
Number of Cylinders		2	2	2	2	2	2
Displacement	(in ³)	40.3	50.0	50.0	60.0	60.0	60.0
	(cm ³)	660.0	815.0	815.0	980.5	980.5	985.7
Stroke	(in)	2.625	3.000	3.000	3.000	3.000	3.625
	(mm)	66.675	76.20	76.20	76.20	76.20	90.075
Bore (Honed)	(in)	3.1245	3.2490	3.2490	3.5625	3.5625	3.2495
	(in)	3.1255	3.2500	3.2500	3.5635	3.5635	3.2505
	(mm)	79.362	82.525	82.525	90.488	90.488	82.537
	(mm)	79.388	82.550	82.550	90.513	90.513	82.563
Piston Diameter ⑤	(in)	3.1225	3.2465	3.2465	3.5600	3.5600	3.2470
	(in)	3.1235	3.2475	3.2475 ⑥	3.5610	3.5610	3.2480
	(mm)	79.312	82.461	82.461 ⑥	90.424	90.424	82.474
	(mm)	79.337	82.487	82.487	90.449	90.449	82.499
Measurement Taken at ①		X	X	X	X	X	X
Clearance in Cylinder	(in)	.0010	.0015	.0015	.0015	.0015	.0012
	(in)	.0030	.0035	.0035 ②	.0035	.0035	.0032
	(mm)	0.025	0.038	0.038 ②	0.038	0.038	0.030
	(mm)	0.076	0.089	0.089	0.089	0.089	0.081
Ring Gap	(in)	.0100	.0100	.0100	.0100	.0100	.0100
	(in)	.0200	.0230	.0230	.0200	.0200	.0200
	(mm)	0.254	0.254	0.254	0.254	0.254	0.254
	(mm)	0.508	0.584	0.584	0.508	0.508	0.508
Piston Pin Diameter ⑤	(in)	.6875	.7500	.7500	.7500	.7500	.9899
	(in)	.6877	.7502	.7502	.7502	.7502	.9901
	(mm)	17.463	19.050	19.050	19.050	19.050	25.143
	(mm)	17.468	19.055	19.055	19.055	19.055	25.148
Piston Pin Fit in Rod	(in)	.0002	.0002	.0002	.0002	.0002	.0002
	(in)	.0004	.0007	.0007	.0007	.0007	.0007
	(mm)	0.005	0.005	0.005	0.005	0.005	0.005
	(mm)	0.010	0.018	0.018	0.018	0.018	0.018
Piston Ring Groove Width No. 1 (Top)	(in)	.0800	.0960	.0960	.0955	.0955	.0960
	(in)	.0810	.0970	.0970	.0965	.0965	.0970
	(mm)	2.032	2.438	2.438	2.426	2.426	2.438
	(mm)	2.057	2.464	2.464	2.451	2.451	2.464
Piston Ring Groove Width No. 2	(in)	.0800	.0955	.0955	.0955	.0955	.0955
	(in)	.0810	.0965	.0965	.0965	.0965	.0965
	(mm)	2.032	2.426	2.426	2.426	2.426	2.426
	(mm)	2.057	2.451	2.451	2.451	2.451	2.451
Piston Ring Groove Width No. 3	(in)	.1880	.1880	.1880	.1880	.1880	.1880
	(in)	.1890	.1895	.1895	.1890	.1890	.1895
	(mm)	4.775	4.775	4.775	4.775	4.775	4.775
	(mm)	4.800	4.813	4.813	4.800	4.800	4.813
Piston Ring Groove Width No. 4		NA	NA	NA	NA	NA	NA
Side Clearance Top Ring	(in)	.020	.020	.020	.020	.020	.020
	(in)	.040	.080	.080	.080	.080	.080
	(mm)	0.508	0.508	0.508	0.508	0.508	0.508
	(mm)	1.016	2.032	2.032	2.032	2.032	2.032

Footnotes. See page 4-25

TABLE 4-1. DIMENSIONS AND CLEARANCES. TWO CYLINDER GASOLINE MODELS

MODEL		BF	CCK MCKK	CCKA CCKB	NH	NHA, NHB, NHC	JB MJB
Valve Spring Free Length	(in)	1.6620	1.6620	1.6620	1.6620	1.6620	1.8750
	(mm)	42.214	41.214	42.214	42.214	42.214	47.625
Valve Spring Compressed	(in)	1.3750	1.3750	1.3750	1.3750	1.3750	1.5280
	(mm)	34.925	34.925	34.925	34.925	34.925	38.811
Valve Spring Tension Open	(lb)	71-79	71-79	71-79	71-79	71-79	87-97
	(N)	9.8-10.9	9.8-10.9	9.8-10.9	9.8-10.9	9.8-10.9	12.0-13.4
Valve Spring Tension Closed	(lb)	38-42	38-42	38-42	38-42	38-42	45-49
	(N)	5.25-5.8	5.25-5.8	5.25-5.8	5.25-5.8	5.25-5.8	6.2-6.8
Valve Seat Angle in Deg		45	45	45	45	45	45
Valve Face Angle in Deg	Ext/Int	44	44	44	44	44	45
Valve Seat Width	(in)	.031-.047	.031-.047	.031-.047	.031-.047	.031-.047	.047-.063
	(mm)	0.79-1.194	0.79-1.194	0.79-1.194	0.79-1.194	0.79-1.194	1.194-1.600
Valve Seat (Intake) Bore Diameter	(in)	1.4430	NA	1.443	1.5645	1.5645	1.5470
	(in)	1.444	NA	1.444	1.5655	1.5655	1.5480
	(mm)	36.652	NA	36.652	39.738	39.738	39.294
	(mm)	36.678	NA	36.678	39.784	39.784	39.319
Valve Seat (Exhaust) Bore Diameter	(in)	1.1890	1.1890	1.1890	1.2510	1.2510	1.3610
	(in)	1.1900	1.1900	1.1900	1.2520	1.2520	1.3620
	(mm)	30.200	30.200	30.200	31.775	31.775	31.569
	(mm)	30.226	30.226	30.226	31.800	31.800	34.595
Valve Seat (Intake) Diameter	(in)	1.4460	NA	1.4460	1.5690	1.5690	1.5500
	(in)	1.4470	NA	1.4470	1.5700	1.5700	1.5510
	(mm)	36.728	NA	36.728	39.853	39.853	39.370
	(mm)	36.754	NA	36.754	39.878	39.878	39.395
Valve Seat (Exhaust) Diameter	(in)	1.1920	1.1920	1.1920	1.2550	1.2550	1.3640
	(in)	1.1930	1.1930	1.1930	1.2560	1.2560	1.3650
	(mm)	30.277	30.277	30.277	31.877	31.877	34.646
	(mm)	30.302	30.302	30.302	31.902	31.902	34.671
Valve Stem Diameter (Intake)	(in)	.3425	.3425	.3425	.3425	.3425	.3405
	(in)	.3430	.3430	.3430	.3430	.3430	.3415
	(mm)	8.709	8.700	8.700	8.700	8.700	8.649
	(mm)	8.712	8.712	8.712	8.712	8.712	8.674
Valve Stem Diameter (Exhaust)	(in)	.3410	.3410	.3410	.3410	.3410	.3405
	(in)	.3415	.3415	.3415	.3415	.3415	.3415
	(mm)	8.661	8.661	8.661	8.661	8.661	8.649
	(mm)	8.674	8.674	8.674	8.674	8.674	8.674
Valve Guide Diameter	(in)	.3440	.3440	.3440	.3440	NA	NA
	(in)	.3460	.3460	.3460	.3460	NA	NA
	(mm)	8.738	8.738	8.738	8.738	NA	NA
	(mm)	8.788	8.788	8.788	8.788	NA	NA
After Reaming: Intake	(in)	NA	NA	NA	NA	NA	.3425
	(in)	NA	NA	NA	NA	NA	.3435
	(mm)	NA	NA	NA	NA	NA	8.700
	(mm)	NA	NA	NA	NA	NA	8.725
After Reaming: Exhaust	(in)	NA	NA	NA	NA	NA	.3445
	(in)	NA	NA	NA	NA	NA	.3455
	(mm)	NA	NA	NA	NA	NA	8.750
	(mm)	NA	NA	NA	NA	NA	8.776

another free manual from www.searctractormanuals.com

TABLE 4-1. DIMENSIONS AND CLEARANCES. TWO CYLINDER GASOLINE MODELS

MODEL		BF	CCK MCKK	CCKA CCKB	NH	NHA, NHB. NHC	JB MJB
Valve Stem Clearance Intake	(in)	.0010	.0010	.0010	.0010	.0010	.0010
	(in)	.0025	.0025	.0025	.0025	.0025	.0030
	(mm)	0.025	0.025	0.025	0.025	0.025	0.025
	(mm)	0.064	0.064	0.064	0.064	0.064	0.076
Valve Stem Clearance Exhaust	(in)	.0025	.0025	.0025	.0025	.0025	.0030
	(in)	.0040	.0040	.0040	.0040	.0040	.0050
	(mm)	0.064	0.064	0.064	0.064	0.064	0.076
	(mm)	0.102	0.102	0.102	0.102	0.102	0.127
Valve Lifter Diameter ⁽⁹⁾	(in)	.7475	.7475	.7475	.7475	.7475	.8725
	(in)	.7480	.7480	.7480	.7480	.7480	.8730
	(mm)	18.987	18.987	18.987	18.987	18.987	22.162
	(mm)	19.000	19.000	19.000	19.000	22.174	
Valve Lifter Bore	(in)	.7505	.7505	.7505	.7505	.7505	.8755
	(in)	.7515	.7515	.7515	.7515	.7515	.8765
	(mm)	19.063	19.063	19.063	19.063	19.063	22.238
	(mm)	19.088	19.088	19.088	19.088	19.088	22.263
Valve Clearance - Intake (Cold)	(in)	.0080	.0070 ⁽⁷⁾	.0070	.0030	.0030	.0120 ⁽¹⁾
	(mm)	0.203	0.178	0.178	0.076	0.076	0.305
Valve Clearance - Exhaust (Cold)	(in)	.0130	.0160	.0160	.0100	.0100	.0150 ⁽⁸⁾
	(mm)	0.330	0.406	0.406	0.254	0.254	0.381
Diameter Crankshaft Main Bearing	(in)	1.9992	1.9992	1.9992	1.9992	1.9992	2.2437
	(in)	2.0000	2.0000	2.0000	2.0000	2.0000	2.2445
	(mm)	50.780	50.780	50.780	50.780	50.780	57.000
	(mm)	50.800	50.800	50.800	50.800	50.800	57.010
Diameter Crankshaft Rod Journal	(in)	1.6250	1.6250	1.6250	1.6250	1.6250	2.0597
	(in)	1.6252	1.6252	1.6252	1.6252	1.6252	2.0606
	(mm)	41.275	41.275	41.275	41.275	41.275	52.316
	(mm)	41.280	41.280	41.280	41.280	41.280	52.337
Crankshaft End Play	(in)	.0060	.0060	.0060	.0050	.0050	.0100
	(in)	.0120	.0120	.0120	.0090	.0090	.0150
	(mm)	0.152	0.152	0.152	0.127	0.127	0.254
	(mm)	0.305	0.305	0.305	0.229	0.229	0.381
Main Bearing Diameter	(in)	2.0015	2.0020	2.0015	2.0015	2.0015	2.459
	(in)	2.0040	2.0030 ⁽⁹⁾	2.0040	2.0040	2.0040	2.489
	(mm)	50.838	50.850	50.838	50.838	50.838	62.459
	(mm)	50.902	50.880	50.902	50.902	50.902	63.221
Main Bearing Clearance	(in)	.0025	.0025	.0025	.0025	.0025	.0014
	(in)	.0038	.0038	.0038	.0038	.0038	.0052
	(mm)	0.064	0.064	0.064	0.064	0.064	0.036
	(mm)	0.097	0.097	0.097	0.097	0.097	0.132
Connecting Rod Side Clearance	(in)	.0020	.0020	.0020	.0020	.0020	.0020
	(in)	.0160	.0160	.0160	.0160	.0160	.0160
	(mm)	0.051	0.051	0.051	0.051	0.051	0.051
	(mm)	0.406	0.406	0.406	0.406	0.406	0.406
Connecting Rod Bearing Clearance	(in)	.0020	.0005	.0005	.0005	.0005	.0010
	(in)	.0033	.0023 ⁽¹⁰⁾	.0023 ⁽¹⁰⁾	.0023	.0023	.0033
	(mm)	0.051	0.013	0.013	0.013	0.013	0.025
	(mm)	0.084	0.058	0.058	0.058	0.058	0.084
Camshaft Bearing Clearance	(in)	.0015	.0015	.0015	.0015	.0015	.0012
	(in)	.0030	.0030	.0030	.0030	.0030	.0037
	(mm)	0.038	0.038	0.038	0.038	0.038	0.030
	(mm)	0.076	0.076	0.076	0.076	0.076	0.094

Footnotes. See page 4-25

Rev
7-75

TABLE 4-1. DIMENSIONS AND CLEARANCES. TWO CYLINDER GASOLINE MODELS

MODEL		BF	CCK MCKK	CCKA CCKB	NH	NHA, NHB, NHC	JB MJB
Camshaft End Play	(in)	.0030	.0030	.0030	.0030	.0030	.0070
	(in)	min.	min.	min.	.0120	.0120	.0390
	(mm)	0.076	0.076	0.076	0.076	0.076	0.178
	(mm)	—	—	—	0.305	0.305	0.891
Camshaft Lift	(in)	.300	.243	.243	.300	.300	Ⓢ
	(mm)	7.62	6.172	6.172	7.62	7.62	
Camshaft Bearing Diameter 1	(in)	1.3760	1.3760	1.3760	1.3760	1.3745	2.2510
	(in)	1.3770	1.3770	1.3770	1.3770	1.3760	2.2530
	(mm)	34.950	34.950	34.950	34.950	34.912	57.175
	(mm)	34.976	34.976	34.976	34.976	34.950	57.228
Camshaft Bearing Diameter 2	(in)	1.3760	1.3760	1.3760	1.3760	NA	1.169
	(in)	1.3770	1.3770	1.3770	1.3770		1.191
	(mm)	34.950	34.950	34.950	34.950		30.200
	(mm)	34.976	34.976	34.976	34.976		30.251
Camshaft Bearing Diameter 3	(in)	NA	NA	NA	NA	NA	NA
	(in)						
	(mm)						
	(mm)						
Camshaft Journal Diameter 1	(in)	1.3740	1.3740	1.3740	1.3740	1.3740	2.2500
	(in)	1.3745	1.3745	1.3745	1.3745	1.3745	2.2505
	(mm)	34.900	34.900	34.900	34.900	34.900	57.150
	(mm)	34.912	34.912	34.912	34.912	34.912	57.163
Camshaft Journal Diameter 2	(in)	1.3740	1.3740	1.3740	1.3740	NA	1.1875
	(in)	1.3745	1.3745	1.3745	1.3745		1.1880 Ⓢ
	(mm)	34.900	34.900	34.900	34.900		30.163
	(mm)	34.912	34.912	34.912	34.912		30.175
Camshaft Journal Diameter 3	(in)	NA	NA	NA	NA	NA	NA
	(mm)						
	(in)						
	(mm)						
Ignition Point Gap	(in)	.025	.0200	.0200	.0200	.0160	.0190
	(in)	nom.	nom.	nom.	nom.	nom.	.0210
	(mm)	0.635	0.508	0.508	0.508	0.406	0.483
	(mm)	nom.	nom.	nom.	nom.	nom.	0.533
Spark Plug Gap (Gasoline)	(in)	.025	.025	.025	.025	.025	.025
	(mm)	0.635	0.635	0.635	0.635	0.635	0.635
Spark Plug Gap (Gas)	(in)	.018	.018	.018	.018	.018	.025
	(mm)	0.457	0.457	0.457	0.457	0.457	0.635
Ignition Timing: Gasoline Deg. BTC (Running)		21	19/ 20	24	20	25	25
Ignition Timing: Gas Deg. BTC (Running)		22	24 Ⓢ	24	22	25	Ⓢ
Injection Pump Timing		NA	NA	NA	NA	NA	NA
Nozzle Opening	(PSI) (N+M)	NA	NA	NA	NA	NA	NA
Compression (Sea Level)	(PSI) (kPa)	110-120 758.0-827.0	100-120 Ⓢ 689.0-827.0	100-120 689.0-827.0	100-120 689.0-827.0	115 793	120-140 Ⓢ 827.0-965
Flicker Point Gap	(in) (mm)	NA	NA	NA	NA	NA	NA
Start Disconnect	(in) (mm)	NA	NA	NA	NA	NA	.020 0.508

Footnotes. See page 4-25

another free manual from www.searctractormaterials.com

TABLE 4-1. DIMENSIONS AND CLEARANCES. FOUR CYLINDER GASOLINE MODELS

MODEL		JC	MJC	RJC
Number of Cylinders		4	4	4
Displacement	(in ³) (cm ³)	120 1.971 litre	120 1.971 litre	120 1.971 litre
Stroke	(in) (mm)	3.625 92.075	3.625 92.075	3.625 92.075
Bore (Honed)	(in) (in) (mm) (mm)	3.2495 3.2505 82.537 82.563	3.2495 3.2505 82.537 82.563	3.2495 3.2505 82.537 82.563
Piston Diameter	(in) (in) (mm) (mm)	3.2470 3.2480 82.484 82.499	3.2470 3.2480 82.484 82.499	3.2470 3.2480 82.484 82.499
Measurement Taken at ①		X	X	X
Clearance in Cylinder	(in) (in) (mm) (mm)	.0012 .0032 0.030 0.081	.0012 .0032 0.030 0.081	.0012 .0032 0.030 0.081
Ring Gap	(in) (in) (mm) (mm)	.0100 .0200 0.254 0.508	.0100 .0200 0.254 0.508	.0100 .0200 0.254 0.508
Piston Pin Diameter	(in) (in) (mm) (mm)	.9899 .9901 25.144 25.149	.9899 .9901 25.144 25.149	.9899 .9901 25.144 25.149
Piston Pin Fit in Rod	(in) (in) (mm) (mm)	.0002 .0007 0.005 0.018	.0002 .0007 0.005 0.018	.0002 .0007 0.005 0.018
Piston Ring Groove Width No. 1 (Top)	(in) (in) (mm) (mm)	.0925 .0935 2.350 2.375	.0925 .0935 2.350 2.375	.0925 .0935 2.350 2.375
Piston Ring Groove Width No. 2	(in) (in) (mm) (mm)	.0925 .0935 2.350 2.375	.0925 .0935 2.350 2.375	.0925 .0935 2.350 2.375
Piston Ring Groove Width No. 3	(in) (in) (mm) (mm)	.1860 .1865 4.724 4.737	.1860 .1865 4.724 4.737	.1860 .1865 4.724 4.737
Piston Ring Groove Width No. 4		NA	NA	NA
Side Clearance Top Ring	(in) (in) (mm) (mm)	.0020 .0080 0.050 0.203	.0020 .0080 0.050 0.203	.0020 .0080 0.050 0.203

Footnotes. See page 4-25

TABLE 4-1. DIMENSIONS AND CLEARANCES. FOUR CYLINDER GASOLINE MODELS

MODEL		JC	MJC	RJC
Valve Spring Free Length	(in)	1.8750	1.8750	1.8750
	(mm)	47.625	47.625	47.625
Valve Spring Compressed Length	(in)	1.5280	1.5280	1.5280
	(mm)	38.8112	38.8112	38.8112
Valve Spring Tension Open	(lb)	87-97 (1)	87-97 (1)	87-97 (1)
	(N)	12-13.5	12-13.5	12-13.5
Valve Spring Tension Closed	(lb)	45-49	45-49	45-49
	(N)	6.2-6.8	6.2-6.8	6.2-6.8
Valve Seat Angle in Deg		45	45	45
Valve Face Angle in Deg	Exh/Int	45	45	45
Valve Seal Width	(in)	.047-.063	.047-.063	.047-.063
	(mm)	1.2-1.6	1.2-1.6	1.2-1.6
Valve Seal Bore Diameter (Intake)	(in)	1.547	1.547	1.547
	(in)	1.548	1.548	1.548
	(mm)	39.294	39.294	39.294
	(mm)	39.319	39.319	39.319
Valve Seal Bore Diameter (Exhaust)	(in)	1.3610	1.3610	1.3610
	(in)	1.3620	1.3620	1.3620
	(mm)	34.570	34.570	34.570
	(mm)	34.595	34.595	34.595
Valve Seat (Intake) Diameter	(in)	1.550	1.550	1.550
	(in)	1.5510	1.5510	1.5510
	(mm)	39.370	39.370	39.370
	(mm)	39.395	39.395	39.395
Valve Seat (Exhaust) Diameter	(in)	1.3640	1.3640	1.3640
	(in)	1.3650	1.3650	1.3650
	(mm)	34.646	34.646	34.646
	(mm)	34.671	34.671	34.671
Valve Stem Diameter (Intake)	(in)	.3405	.3405	.3405
	(in)	.3415	.3415	.3415
	(mm)	8.650	8.650	8.650
	(mm)	8.674	8.674	8.674
Valve Stem Diameter (Exhaust)	(in)	.3405	.3405	.3405
	(in)	.3415	.3415	.3415
	(mm)	8.650	8.650	8.650
	(mm)	8.674	8.674	8.674
Valve Guide Diameter	(in)	NA	NA	NA
	(in)			
	(mm)			
	(mm)			
After Reaming: Intake	(in)	.3425	.3425	.3425
	(in)	.3435	.3435	.3435
	(mm)	8.700	8.700	8.700
	(mm)	8.725	8.725	8.725
After Reaming: Exhaust	(in)	.3445	.3445	.3445
	(in)	.3455	.3455	.3455
	(mm)	8.750	8.750	8.750
	(mm)	8.775	8.775	8.775

Footnotes: See page 4-25

TABLE 4-1. DIMENSIONS AND CLEARANCES. FOUR CYLINDER GASOLINE MODELS

MODEL		JC	MJC	RJC
Valve Stem Clearance Intake	(in)	.0010	.0010	.0010
	(in)	.0030	.0030	.0030
	(mm)	0.025	0.025	0.025
	(mm)	0.076	0.076	0.076
Valve Stem Clearance Exhaust	(in)	.0030	.0030	.0030
	(in)	.0050	.0050	.0050
	(mm)	0.076	0.076	0.076
	(mm)	0.127	0.127	0.127
Valve Lifter Diameter (3)	(in)	.8725	.8725	.8725
	(in)	.8730	.8730	.8730
	(mm)	22.162	22.162	22.162
	(mm)	22.174	22.174	22.174
Valve Lifter Bore	(in)	.8755	.8755	.8755
	(in)	.8765	.8765	.8765
	(mm)	22.234	22.234	22.234
	(mm)	22.263	22.263	22.263
Valve Clearance - Intake (Cold)	(in)	.0120	.0150	.0150
	(mm)	0.305	0.381	0.381
Valve Clearance - Exhaust (Cold)	(in)	.015	.020	.0200
	(mm)	0.381	0.508	0.508
Diameter Crankshaft Main Bearing	(in)	2.2427	2.2427	2.2427
	(in)	2.2435	2.2435	2.2435
	(mm)	56.965	56.965	56.965
	(mm)	56.985	56.985	56.985
Diameter Crankshaft Rod Journal	(in)	2.0597	2.0597	2.0597
	(in)	2.0605	2.0605	2.0605
	(mm)	52.316	52.316	52.316
	(mm)	52.337	52.337	52.337
Crankshaft End Play	(in)	.0100	.0100	.0100
	(in)	.0150	.0150	.0150
	(mm)	0.254	0.254	0.254
	(mm)	0.381	0.381	0.381
Main Bearing Diameter	(in)	2.2459	2.2459	2.2459
	(in)	2.2489	2.2489	2.2489
	(mm)	57.046	57.046	57.046
	(mm)	57.122	57.122	57.122
Main Bearing Clearance	(in)	.0024	.0024	.0024
	(in)	.0062	.0062	.0062
	(mm)	0.061	0.061	0.061
	(mm)	0.157	0.157	0.157
Connecting Rod Side Clearance	(in)	.0020	.0020	.0020
	(in)	.0160	.0160	.0160
	(mm)	0.051	0.051	0.051
	(mm)	0.406	0.406	0.406
Connecting Rod Bearing Clearance	(in)	.0010	.0010	.0010
	(in)	.0033	.0033	.0033
	(mm)	0.025	0.025	0.025
	(mm)	0.084	0.084	0.084
Camshaft Bearing Clearance	(in)	.0012	.0012	.0012
	(in)	.0037	.0037	.0037
	(mm)	0.030	0.030	0.030
	(mm)	0.094	0.094	0.094

Footnotes. See page 4-25

TABLE 4-1. DIMENSIONS AND CLEARANCES. FOUR CYLINDER GASOLINE MODELS

MODEL		JC	MJC	RJC
Camshaft End Play	(in)	.0070	.0070	.0070
	(in)	.0390	.0390	.0390
	(mm)	0.178	0.178	0.178
	(mm)	0.991	0.991	0.991
Camshaft Lift		Ⓢ	Ⓢ	Ⓢ
Camshaft Bearing Diameter 1	(in)	2.251	2.251	2.251
	(in)	2.253	2.253	2.253
	(mm)	57.175	57.175	57.175
	(mm)	57.226	57.226	57.226
Camshaft Bearing Diameter 2	(in)	1.2600	1.2600	1.2600
	(in)	1.2630	1.2630	1.2630
	(mm)	32.004	32.004	32.004
	(mm)	32.080	32.080	32.080
Camshaft Bearing Diameter 3	(in)	1.1890	1.1890	1.1890
	(in)	1.1910	1.1910	1.1910
	(mm)	30.200	30.200	30.200
	(mm)	30.251	30.251	30.251
Camshaft Journal Diameter 1	(in)	2.2500	2.2500	2.2500
	(in)	2.2505	2.2505	2.2505
	(mm)	57.150	57.150	57.150
	(mm)	57.163	57.163	57.163
Camshaft Journal Diameter 2	(in)	1.2580	1.2580	1.2580
	(in)	1.2582	1.2582	1.2582
	(mm)	31.953	31.953	31.953
	(mm)	31.958	31.958	31.958
Camshaft Journal Diameter 3	(in)	1.1875	1.1875	1.1875
	(in)	1.1880	1.1880	1.1880
	(mm)	30.163	30.163	30.163
	(mm)	30.175	30.175	30.175
Ignition Point Gap	(in)	.0180	.0180	.0180
	(in)	.0220	.0220	.0220
	(mm)	0.457	0.457	0.457
	(mm)	0.559	0.559	0.559
Spark Plug Gap (Gasoline)	(in)	.035 nom	.035 nom	.035 nom
	(mm)	0.89	0.89	0.89
Spark Plug Gap (Gas)	(in)	.035 nom	.035 nom	.035 nom
	(mm)	0.89	0.89	0.89
Ignition Timing: Gasoline Deg. BTC (Running)		25	25	25
Ignition Timing: Gas Deg. BTC (Running)		Ⓢ	Ⓢ	Ⓢ
Injection Pump Timing		NA	NA	NA
Nozzle Opening		(PSI) (N*m)	NA	NA
Compression (Sea Level)	(PSI)	120-140 Ⓢ	120-140 Ⓢ	120-140 Ⓢ
	(kPa)	827-965	827-965	827-965
Flicker Point Gap		(in) (mm)	NA	NA
Start Disconnect	(in)	.0200	.0200	.0200
	(mm)	0.51	0.51	0.51

Footnotes. See page 4-25

**TABLE 4-2. DIMENSIONS AND CLEARANCES
ONE AND TWO CYLINDER DIESEL MODELS**

MODEL		DJA	MDJA	DJB DJBA	MDJB	MDJE
Number of Cylinders		1	1	2	2	2
Displacement	(in ³) (cm ³)	30.0 493.0	30.0 493.0	60.0 986.0	60.0 986.0	70.0 1.143 litre
Stroke	(in) (mm)	3.625 92.075	3.625 92.075	3.625 92.075	3.625 92.075	3.625 92.075
Bore (Honed)	(in) (in) (mm) (mm)	3.2495 3.2505 82.537 82.563	3.2495 3.2505 82.537 82.563	3.2495 3.2505 82.537 82.563	3.2495 3.2505 82.537 82.563	3.4995 3.5005 88.887 88.913
Piston Diameter	(in) (in) (mm) (mm)	3.2430 3.2440 82.372 82.398	3.2430 3.2440 82.372 82.398	3.2430 3.2440 82.372 82.398	3.2430 3.2440 82.372 82.398	3.4930 3.4940 88.722 88.748
Measurement Taken at (1)		X	X	X	X	X
Clearance in Cylinder	(in) (in) (mm) (mm)	.0055 .0075 (10) 0.140 0.190	.0055 .0075 (10) 0.140 0.190	.0055 .0075 (14) 0.140 0.190	.0055 .0075 (13) 0.140 0.190	.0055 .0075 (18) 0.140 0.190
Ring Gap	(in) (in) (mm) (mm)	.0100 .0200 0.254 0.508	.0100 .0200 0.254 0.508	.0100 .0200 0.254 0.508	.0100 .0200 0.254 0.508	.0100 .0200 0.254 0.508
Piston Pin Diameter	(in) (in) (mm) (mm)	.9899 .9901 25.143 25.149	.9899 .9901 25.143 25.149	.9899 .9901 25.143 25.149	.9899 .9901 25.143 25.149	.9899 .9901 25.143 25.149
Piston Pin Fit in Rod	(in) (in) (mm) (mm)	.0002 .0007 0.005 0.018	.0002 .0007 0.005 0.018	.0002 .0007 0.005 0.018	.0002 .0007 0.005 0.018	.0002 .0007 0.005 0.018
Piston Ring Groove Width No. 1 (Top)	(in) (in) (mm) (mm)	.0970 .0980 2.464 2.489	.0970 .0980 2.464 2.489	.0970 .0980 2.464 2.489	.0970 .0980 2.464 2.489	.0970 .0980 2.464 2.489
Piston Ring Groove Width No. 2	(in) (in) (mm) (mm)	.0965 .0975 2.451 2.477	.0965 .0975 2.451 2.477	.0965 .0975 2.451 2.477	.0965 .0975 2.451 2.477	.0965 .0975 2.451 2.477
Piston Ring Groove Width No. 3	(in) (in) (mm) (mm)	.0965 .0975 2.451 2.477	.0965 .0975 2.451 2.477	.0965 .0975 2.451 2.477	.0965 .0975 2.451 2.477	.0965 .0975 2.451 2.477
Piston Ring Groove Width No. 4	(in) (in) (mm) (mm)	.1880 .1895 4.775 4.813	.1880 .1895 4.775 4.813	.1880 .1895 4.775 4.813	.1880 .1895 4.775 4.813	.1880 .1895 4.775 4.813
Side Clearance Top Ring	(in) (in) (mm) (mm)	.0020 .0060 0.050 0.152	.0020 .0060 0.050 0.152	.0020 .0060 0.050 0.152	.0020 .0060 0.050 0.152	.0020 .0060 0.050 0.152

Footnotes. See page 4-25

**TABLE 4-2. DIMENSIONS AND CLEARANCES.
ONE AND TWO CYLINDER DIESEL MODELS**

MODEL		DJA	MDJA	DJB DJBA	MDJB	MOJE
Valve Spring Free Length	(in) (mm)	1.8750 47.625	1.8750 47.625	1.8750 47.625	1.8750 47.625	1.8750 47.625
Valve Spring Compressed Length	(in) (mm)	1.5280 38.811	1.5280 38.811	1.5280 38.811	1.5280 38.811	1.5280 38.811
Valve Spring Tension Open	(lb) (N)	87-97 12.0-13.4	87-97 12.0-13.4	87-97 12.0-13.4	87-97 12.0-13.4	87-97 12.0-13.4
Valve Spring Tension Closed	(lb) (N)	45-49 6.2-6.8	45-49 6.2-6.8	45-49 6.2-6.8	45-49 6.2-6.8	45-49 6.2-6.8
Valve Seat Angle in Deg		45	45	45	45	45
Valve Face Angle in Deg	Ex/Int	45/42	45/42	45/42	45/42	45/42
Valve Seat Width	(in) (mm)	.047-.063 1.2-1.6	.047-.063 1.2-1.6	.047-.063 1.2-1.6	.047-.063 1.2-1.6	.047-.063 1.2-1.6
Valve Seat Bore Diameter (Intake)	(in) (in) (mm) (mm)	1.3610 1.3620 34.570 34.595	1.3610 1.3620 34.570 34.595	1.3610 1.3620 34.570 34.595	1.3610 1.3620 34.570 34.595	1.3610 1.3620 34.570 34.595
Valve Seat Bore Diameter (Exhaust)	(in) (in) (mm) (mm)	1.3640 1.3650 34.646 34.671	1.3640 1.3650 34.646 34.671	1.3640 1.3650 34.646 34.671	1.3640 1.3650 34.646 34.671	1.3640 1.3650 34.646 34.671
Valve Seat Diameter (Intake)	(in) (in) (mm) (mm)	1.3640 1.3650 34.646 34.671	1.3640 1.3650 34.646 34.671	1.3640 1.3650 34.646 34.671	1.3640 1.3650 34.646 34.671	1.3640 1.3650 34.646 34.671
Valve Seat Diameter (Exhaust)	(in) (in) (mm) (mm)	1.3640 1.3650 34.646 34.671	1.3640 1.3650 34.646 34.671	1.3640 1.3650 34.646 34.671	1.3640 1.3650 34.646 34.671	1.3640 1.3650 34.646 34.671
Valve Stem Diameter (Intake)	(in) (in) (mm) (mm)	.3405 .3410 8.649 8.661	.3405 .3410 8.649 8.661	.3405 .3410 8.649 8.661	.3405 .3410 8.649 8.661	.3405 .3410 8.649 8.661
Valve Stem Diameter (Exhaust)	(in) (in) (mm) (mm)	.3405 .3410 8.649 8.661	.3405 .3410 8.649 8.661	.3405 .3410 8.649 8.661	.3405 .3410 8.649 8.661	.3405 .3410 8.649 8.661
Valve Guide Diameter		NA	NA	NA	NA	NA
After Reaming (Intake)	(in) (in) (mm) (mm)	.3425 .3435 8.700 8.725	.3425 .3435 8.700 8.725	.3425 .3435 8.700 8.725	.3425 .3435 8.700 8.725	.3425 .3435 8.700 8.725
After Reaming (Exhaust)	(in) (in) (mm) (mm)	.3445 .3455 8.750 8.775	.3445 .3455 8.750 8.775	.3445 .3455 8.750 8.775	.3445 .3455 8.750 8.775	.3445 .3455 8.750 8.775

another free manual from www.searstractormanuals.com

**TABLE 4-2. DIMENSIONS AND CLEARANCES.
ONE AND TWO CYLINDER DIESEL MODELS**

MODEL		DJA	MDJA	DJB DJBA	MDJB	MDJE
Valve Stem Clearance (Intake)	(in)	.0015	.0015	.0015	.0015	.0015
	(in)	.0030	.0030	.0030	.0030	.0030
	(mm)	0.038	0.038	0.038	0.038	0.038
	(mm)	0.076	0.076	0.076	0.076	0.076
Valve Stem Clearance (Exhaust)	(in)	.0030	.0030	.0030	.0030	.0030
	(in)	.0050	.0050	.0050	.0050	.0050
	(mm)	0.076	0.076	0.076	0.076	0.076
	(mm)	0.127	0.127	0.127	0.127	0.127
Valve Lifter Diameter	(in)	.8725	.8725	.8725	.8725	.8725
	(in)	.8730 (11)	.8730 (11)	.8730 (11)	.8730 (11)	.8730 (11)
	(mm)	22.162	22.162	22.162	22.162	22.162
	(mm)	22.174	22.174	22.274	22.174	22.174
Valve Lifter Bore	(in)	.8755	.8755	.8755	.8755	.8755
	(in)	.8765	.8765	.8765	.8765	.8765
	(mm)	22.238	22.238	22.238	22.238	22.238
	(mm)	22.263	22.263	22.263	22.263	22.263
Valve Clearance - Intake (Cold)	(in)	.0110	.0200	.0090	.0150	.0170
	(mm)	0.279	0.508	0.229	0.381	0.432
Valve Clearance - Exhaust (Cold)	(in)	.0080	.0200	.0070	.0130	.0170
	(mm)	0.203	0.508	0.178	0.330	0.432
Diameter Crankshaft Main Bearing	(in)	2.2437	2.2437	2.2437	2.2437	2.2437
	(in)	2.2445	2.2445	2.2445	2.2445	2.2445
	(mm)	57.000	57.000	57.000	57.000	57.000
	(mm)	57.010	57.010	57.010	57.010	57.010
Diameter Crankshaft Rod Journal	(in)	2.0597	2.0597	2.0600	2.0600	2.0597
	(in)	2.0605	2.0605	2.0605	2.0605	2.0605
	(mm)	52.316	52.316	52.324	52.324	52.316
	(mm)	52.337	52.337	52.337	52.337	52.337
Crankshaft End Play	(in)	.0100	.0100	.0100	.0100	.0100
	(in)	.0150	.0150	.0150	.0150	.0150
	(mm)	0.254	0.254	0.254	0.254	0.254
	(mm)	0.381	0.381	0.381	0.381	0.381
Main Bearing Diameter	(in)	2.2459	2.2459	2.2459	2.2459	2.2459
	(in)	2.2489	2.2489	2.2489	2.2489	2.2489
	(mm)	57.046	57.046	57.046	57.046	57.046
	(mm)	57.122	57.122	57.122	57.122	57.122
Main Bearing Clearance	(in)	.0014	.0014	.0014	.0014	.0014
	(in)	.0052	.0052	.0052	.0052	.0052
	(mm)	0.036	0.036	0.036	0.036	0.036
	(mm)	0.132	0.132	0.132	0.132	0.132
Connecting Rod Side Clearance	(in)	.0020	.0020	.0020	.0020	.0020
	(in)	.0160	.0160	.0160	.0160	.0160
	(mm)	0.051	0.051	0.051	0.051	0.051
	(mm)	0.406	0.406	0.406	0.406	0.406
Connecting Rod Bearing Clearance	(in)	.0010	.0010	.0010	.0010	.0010
	(in)	.0033	.0033	.0033	.0033	.0033
	(mm)	0.025	0.025	0.025	0.025	0.025
	(mm)	0.084	0.084	0.084	0.084	0.084
Camshaft Bearing Clearance	(in)	.0012	.0012	.0012	.0012	.0012
	(in)	.0037	.0037	.0037	.0037	.0037
	(mm)	0.030	0.030	0.030	0.030	0.030
	(mm)	0.094	0.094	0.094	0.094	0.094

Footnotes. See page 4-25

**TABLE 4-2. DIMENSIONS AND CLEARANCES.
ONE AND TWO CYLINDER DIESEL MODELS**

MODEL		DJA	MDJA	DJB DJBA	MDJB	MDJE
Camshaft End Play	(in)	.0070	.0070	.0070	.0070	.0070
	(in)	.0390	.0390	.0390	.0390	.0390
	(mm)	0.178	0.178	0.178	0.178	0.178
	(mm)	0.991	0.991	0.991	0.991	0.991
Camshaft Lift	(in)	Ⓢ	Ⓢ	Ⓢ	Ⓢ	Ⓢ
	(mm)					
Camshaft Bearing Diameter 1	(in)	2.2510	2.2510	2.2510	2.2510	2.2510
	(in)	2.2530	2.2530	2.2530	2.2530	2.2530
	(mm)	57.175	57.175	57.175	57.175	57.175
	(mm)	57.226	57.226	57.226	57.226	57.226
Camshaft Bearing Diameter 2	(in)	1.1890	1.1890	1.1890	1.1890	1.2600
	(in)	1.1910	1.1910	1.1910	1.1910	1.2630
	(mm)	30.200	30.200	30.200	30.200	32.004
	(mm)	30.251	30.251	30.251	30.251	32.080
Camshaft Bearing Diameter 3	(in)	NA	NA	NA	NA	NA
	(in)					
	(mm)					
	(mm)					
Camshaft Journal Diameter 1	(in)	2.2500	2.2500	2.2500	2.2500	2.2500
	(in)	2.2505	2.2505	2.2505	2.2505	2.2505
	(mm)	57.150	57.150	57.150	57.150	57.150
	(mm)	57.163	57.163	57.163	57.163	57.163
Camshaft Journal Diameter 2	(in)	1.1875	1.1875	1.1875	1.1875	1.1875
	(in)	1.1880	1.1880	1.1880	1.1880	1.1880
	(mm)	30.163	30.163	30.163	30.163	30.163
	(mm)	30.175	30.175	30.175	30.175	30.175
Camshaft Journal Diameter 3	(in)	NA	NA	NA	NA	NA
	(in)					
	(mm)					
	(mm)					
Ignition Point Gap	(in)	NA	NA	NA	NA	NA
	(in)					
	(mm)					
	(mm)					
Spark Plug Gap (Gasoline)	(in)	NA	NA	NA	NA	NA
	(mm)					
Spark Plug Gap (Gas)	(in)	NA	NA	NA	NA	NA
	(mm)					
Ignition Timing: Gasoline Deg. BTC (Running)		NA	NA	NA	NA	NA
Ignition Timing: Gas Deg. BTC (Running)		NA	NA	NA	NA	NA
Injection Pump Timing		17	17	19	19 Ⓢ	19 Ⓢ
Nozzle Opening	(PSI)	1800	1800	1800	1800	1800
	(MPa)	12.42	12.42	12.42	12.42	12.42
Compression (Sea Level)	(PSI)	350-400	350-400	350-400	350-400	350-400
	(MPa)	2.415-2.76	2.415-2.76	2.415-2.76	2.415-2.76	2.415-2.76
Flicker Point Gap	(in)	0.250	0.250	NA	NA	NA
	(mm)	—	—			
Start Disconnect	(in)	NA	NA	.0400	.0400	.0400
	(mm)			1.016	1.016	1.016

Footnotes. See page 4-25

Rev
7-75

TABLE 4-2. DIMENSIONS AND CLEARANCES. FOUR CYLINDER DIESEL MODELS

MODEL		DJC	MDJC	MDJF	RDJC	RDJF
Number of Cylinders		4	4	4	4	4
Displacement	(in ³) (litres)	120.0 1.971	120.0 1.971	140.0 2.286	120.0 1.971	140.0 2.286
Stroke	(in) (mm)	3.6250 92.075	3.6250 92.075	3.6250 92.075	3.6250 92.075	3.6250 92.075
Bore (Honed)	(in) (in) (mm) (mm)	3.2495 3.2505 82.537 82.563	3.2495 3.2505 82.537 82.563	3.4995 3.5005 88.887 88.913	3.2495 3.2505 82.537 82.563	3.4995 3.5005 88.887 88.913
Piston Diameter	(in) (in) (mm) (mm)	3.2430 3.2440 82.372 82.398	3.2430 3.2440 82.372 82.398	3.4930 3.4940 88.722 88.748	3.2430 3.2440 82.372 82.398	3.4930 3.4940 88.722 88.748
Measurement Taken at ⁽¹⁾		X	X	X	X	X
Clearance in Cylinder	(in) (in) (mm) (mm)	.0055 .0075 ⁽²⁾ 0.140 ⁽²⁾ 0.190	.0055 .0075 ⁽²⁾ 0.140 ⁽²⁾ 0.190	.0055 .0075 ⁽²⁾ 0.140 ⁽²⁾ 0.190	.0055 .0075 ⁽²⁾ 0.140 ⁽²⁾ 0.190	.0055 .0075 ⁽²⁾ 0.140 ⁽²⁾ 0.190
Ring Gap	(in) (in) (mm) (mm)	.0100 .0200 0.254 0.508	.0100 .0200 0.254 0.508	.0100 .0200 0.254 0.508	.0100 .0200 0.254 0.508	.0100 .0200 0.254 0.508
Piston Pin Diameter	(in) (in) (mm) (mm)	.9899 .9901 25.143 25.148	.9899 .9901 25.143 25.148	.9899 .9901 25.143 25.148	.9899 .9901 25.143 25.148	.9899 .9901 25.143 25.148
Piston Pin Fit in Rod	(in) (in) (mm) (mm)	.0002 .0007 0.005 0.018	.0002 .0007 0.005 0.018	.0002 .0007 0.005 0.018	.0002 .0007 0.005 0.018	.0002 .0007 0.005 0.018
Piston Ring Groove Width No. 1	(in) (in) (mm) (mm)	.0970 .0980 2.464 2.489	.0970 .0980 2.464 2.489	.0970 .0980 2.464 2.489	.0970 .0980 2.464 2.489	.0970 .0980 2.464 2.489
Piston Ring Groove Width No. 2	(in) (in) (mm) (mm)	.0965 .0975 2.451 2.477	.0965 .0975 2.451 2.477	.0965 .0975 2.451 2.477	.0965 .0975 2.451 2.477	.0965 .0975 2.451 2.477
Piston Ring Groove Width No. 3	(in) (in) (mm) (mm)	.0965 .0975 2.451 2.477	.0965 .0975 2.451 2.477	.0965 .0975 2.451 2.477	.0965 .0975 2.451 2.477	.0965 .0975 2.451 2.477
Piston Ring Groove Width No. 4	(in) (in) (mm) (mm)	.1880 .1897 4.775 4.818	.1880 .1897 4.775 4.818	.1880 .1897 4.775 4.818	.1880 .1897 4.775 4.818	.1880 .1897 4.775 4.818
Side Clearance Top Ring	(in) (in) (mm) (mm)	.0020 .0060 0.050 0.152	.0020 .0060 0.050 0.152	.0020 .0060 0.050 0.152	.0020 .0060 0.050 0.152	.0020 .0060 0.050 0.152

Footnotes. See page 4-25

TABLE 4-2. DIMENSIONS AND CLEARANCES. FOUR CYLINDER DIESEL MODELS

MODEL		DJC	MDJC	MDJF	RDJC	RDJF
Valve Spring Free Length	(in)	1.8750	1.8750	1.8750	1.8750	1.8750
	(mm)	47.625	47.625	47.625	47.625	47.625
Valve Spring Compressed Length	(in)	1.5280	1.5280	1.5280	1.5280	1.5280
	(mm)	38.811	38.811	38.811	38.811	38.811
Valve Spring Tension Open	(lb)	87-97	87-97	87-97	87-97	87-97
	(N)	12.0-13.4	12.0-13.4	12.0-13.4	12.0-13.4	12.0-13.4
Valve Spring Tension Closed	(lb)	45-49	45-49	45-49	45-49	45-49
	(N)	6.2-6.8	6.2-6.8	6.2-6.8	6.2-6.8	6.2-6.8
Valve Seat Angle in Deg		45	45	45	45	45
Valve Face Angle in Deg	Ex/Int	45/42	45/42	45/42	45/42	45/42
Valve Seal Width	(in)	.047-.063	.047-.063	.047-.063	.047-.063	.047-.063
	(mm)	1.2-1.6	1.2-1.6	1.2-1.6	1.2-1.6	1.2-1.6
Valve Seal Bore Diameter (Intake)	(in)	1.3610	1.3610	1.3610	1.3610	1.3610
	(in)	1.3620	1.3620	1.3620	1.3620	1.3620
	(mm)	34.570	34.570	34.570	34.570	34.570
	(mm)	34.595	34.595	34.595	34.595	34.595
Valve Seal Bore Diameter (Exhaust)	(in)	1.3640	1.3640	1.3640	1.3640	1.3640
	(in)	1.3650	1.3650	1.3650	1.3650	1.3650
	(mm)	34.646	34.646	34.646	34.646	34.646
	(mm)	34.671	34.671	34.671	34.671	34.671
Valve Seal Diameter (Intake)	(in)	1.3640	1.3640	1.3640	1.3640	1.3640
	(in)	1.3650	1.3650	1.3650	1.3650	1.3650
	(mm)	34.646	34.646	34.646	34.646	34.646
	(mm)	34.671	34.671	34.671	34.671	34.671
Valve Seal Diameter (Exhaust)	(in)	1.3640	1.3640	1.3640	1.3640	1.3640
	(in)	1.3650	1.3650	1.3650	1.3650	1.3650
	(mm)	34.646	34.646	34.646	34.646	34.646
	(mm)	34.671	34.671	34.671	34.671	34.671
Valve Stem Diameter (Intake)	(in)	.3405	.3405	.3405	.3405	.3405
	(in)	.3415	.3415	.3415	.3415	.3415
	(mm)	8.649	8.649	8.649	8.649	8.649
	(mm)	8.674	8.674	8.674	8.674	8.674
Valve Stem Diameter (Exhaust)	(in)	.3405	.3405	.3405	.3405	.3405
	(in)	.3415	.3415	.3415	.3415	.3415
	(mm)	8.649	8.649	8.649	8.649	8.649
	(mm)	8.674	8.674	8.674	8.674	8.674
Valve Guide Diameter		NA	NA	NA	NA	NA
After Reaming (Intake)	(in)	.3425	.3425	.3425	.3425	.3425
	(in)	.3435	.3435	.3435	.3435	.3435
	(mm)	8.700	8.700	8.700	8.700	8.700
	(mm)	8.725	8.725	8.725	8.725	8.725
After Reaming (Exhaust)	(in)	.3445	.3445	.3445	.3445	.3445
	(in)	.3455	.3455	.3455	.3455	.3455
	(mm)	8.750	8.750	8.750	8.750	8.750
	(mm)	8.776	8.776	8.776	8.776	8.776

TABLE 4-2. DIMENSIONS AND CLEARANCES. FOUR CYLINDER DIESEL MODELS

MODEL		DJC	MDJC	MDJF	ROJC	ROJF
Valve Stem Clearance (Intake)	(in)	.0015	.0015	.0015	.0015	.0015
	(in)	.0030	.0030	.0030	.0030	.0030
	(mm)	0.038	0.038	0.038	0.038	0.038
	(mm)	0.076	0.076	0.076	0.076	0.076
Valve Stem Clearance (Exhaust)	(in)	.0030	.0030	.0030	.0030	.0030
	(in)	.0050	.0050	.0050	.0050	.0050
	(mm)	0.076	0.076	0.076	0.076	0.076
	(mm)	0.127	0.127	0.127	0.127	0.127
Valve Lifter Diameter	(in)	.8725	.8725	.8725	.8725	.8725
	(in)	.8730 (11)	.8730 (11)	.8730 (11)	.8730 (11)	.8730 (11)
	(mm)	22.162 (11)	22.162 (11)	22.162 (11)	22.162 (11)	22.162 (11)
	(mm)	22.174	22.174	22.174	22.174	22.174
Valve Lifter Bore	(in)	.8755	.8755	.8755	.8755	.8755
	(in)	.8765	.8765	.8765	.8765	.8765
	(mm)	22.238	22.238	22.238	22.238	22.238
	(mm)	22.263	22.263	22.263	22.263	22.263
Valve Clearance - Intake (Cold)	(in)	.0090	.0010	.0170	.0110	.0170
	(mm)	.0229	.025	0.432	0.279	0.432
Valve Clearance - Exhaust (Cold)	(in)	.0070	.0160	.0170	.0160	.0170
	(mm)	0.178	0.406	0.432	0.406	0.432
Diameter Crankshaft Main Bearing	(in)	2.2427	2.2427	2.2427	2.2427	2.2427
	(in)	2.2435	2.2435	2.2435	2.2435	2.2435
	(mm)	56.965	56.965	56.965	56.965	56.965
	(mm)	56.985	56.985	56.985	56.985	56.985
Diameter Crankshaft Rod Journal	(in)	2.0597	2.0597	2.0597	2.0597	2.0597
	(in)	2.0605	2.0605	2.0605	2.0605	2.0605
	(mm)	52.316	52.316	52.316	52.316	52.316
	(mm)	52.337	52.337	52.337	52.337	52.337
Crankshaft End Play	(in)	.0100	.0100	.0100	.0100	.0100
	(in)	.0150	.0150	.0150	.0150	.0150
	(mm)	0.254	0.254	0.254	0.254	0.254
	(mm)	0.381	0.381	0.381	0.381	0.381
Main Bearing Diameter	(in)	2.2459	2.2459	2.2459	2.2459	2.2459
	(in)	2.2489	2.2489	2.2489	2.2489	2.2489
	(mm)	57.046	57.046	57.046	57.046	57.046
	(mm)	57.122	57.122	57.122	57.122	57.122
Main Bearing Clearance	(in)	.0024	.0024	.0024	.0024	.0024
	(in)	.0062	.0062	.0062	.0062	.0062
	(mm)	0.061	0.061	0.061	0.061	0.061
	(mm)	0.157	0.157	0.157	0.157	0.157
Connecting Rod Side Clearance	(in)	.0020	.0020	.0020	.0020	.0020
	(in)	.0160	.0160	.0160	.0160	.0160
	(mm)	0.050	0.050	0.050	0.050	0.050
	(mm)	0.406	0.406	0.406	0.406	0.406
Connecting Rod Bearing Clearance	(in)	.0010	.0010	.0010	.0010	.0010
	(in)	.0033	.0033	.0033	.0033	.0033
	(mm)	0.025	0.025	0.025	0.025	0.025
	(mm)	0.084	0.084	0.084	0.084	0.084
Camshaft Bearing Clearance	(in)	.0012	.0012	.0012	.0012	.0012
	(in)	.0037	.0037	.0037	.0037	.0037
	(mm)	0.030	0.030	0.030	0.030	0.030
	(mm)	0.094	0.094	0.094	0.094	0.094

Footnotes. See page 4-25

TABLE 4-2. DIMENSIONS AND CLEARANCES. FOUR CYLINDER DIESEL MODELS

MODEL		DJC	MDJC	MDJF	RDJC	RDJF
Camshaft End Play	(in)	.0070	.0070	.0070	.0070	.0070
	(in)	.0390	.0390	.0390	.0390	.0390
	(mm)	0.178	0.178	0.178	0.178	0.178
	(mm)	0.990	0.990	0.990	0.990	0.990
Camshaft Lift		⑫	⑫	⑬	⑬	⑬
Camshaft Bearing Diameter 1	(in)	2.2510	2.2510	2.2510	2.2510	2.2510
	(in)	2.2530	2.2530	2.2530	2.2530	2.2530
	(mm)	57.175	57.175	57.175	57.175	57.175
	(mm)	57.226	57.226	57.226	57.226	57.226
Camshaft Bearing Diameter 2	(in)	1.2600	1.2600	1.2600	1.2600	1.2600
	(in)	1.2630	1.2630	1.2630	1.2630	1.2630
	(mm)	32.004	32.004	32.004	32.004	32.004
	(mm)	32.080	32.080	32.080	32.080	32.080
Camshaft Bearing Diameter 3	(in)	1.1890	1.1890	1.1890	1.1890	1.1890
	(in)	1.1910	1.1910	1.1910	1.1910	1.1910
	(mm)	30.209	30.209	30.209	30.209	30.209
	(mm)	30.251	30.251	30.251	30.251	30.251
Camshaft Journal Diameter 1	(in)	2.2500	2.2500	2.2500	2.2500	2.2500
	(in)	2.2505	2.2505	2.2505	2.2505	2.2505
	(mm)	57.150	57.150	57.150	57.150	57.150
	(mm)	57.163	57.163	57.163	57.163	57.163
Camshaft Journal Diameter 2	(in)	1.2580	1.2580	1.2580	1.2580	1.2580
	(in)	1.2582	1.2582	1.2582	1.2582	1.2582
	(mm)	31.953	31.953	31.953	31.953	31.953
	(mm)	31.958	31.958	31.958	31.958	31.958
Camshaft Journal Diameter 3	(in)	1.1875	1.1875	1.1875	1.1875	1.1875
	(in)	1.1880	1.1880	1.1880	1.1880	1.1880
	(mm)	30.163	30.163	30.163	30.163	30.163
	(mm)	30.175	30.175	30.175	30.175	30.175
Ignition Point Gap	(in) (mm)	NA	NA	NA	NA	NA
Spark Plug Gap (Gasoline)	(in) (mm)	NA	NA	NA	NA	NA
Spark Plug Gap (Gas)	(in) (mm)	NA	NA	NA	NA	NA
Ignition Timing: Gasoline Deg. BTC (Running)		NA	NA	NA	NA	NA
Ignition Timing: Gas Deg. BTC (Running)		NA	NA	NA	NA	NA
Injection Pump Timing		19 ⑬	19 ⑬	19 ⑬	19 ⑬	19 ⑬
Nozzle Opening	(PSI)	1800	1800	1800	1800	1800
	(MPa)	12.42	12.42	12.42	12.42	12.42
Compression (Sea Level)	(PSI)	350-400	350-400	350-400	350-400	350-400
	(MPa)	2.415-2.76	2.415-2.76	2.415-2.76	2.415-2.76	2.415-2.76
Flicker Point Gap	(in) (mm)	NA	NA	NA	NA	NA
Start Disconnect	(in)	.0400	.0400	.0400	.0400	.0400
	(mm)	1.016	1.016	1.016	1.016	1.016

Footnotes, See page 4-25

TABLE 4-3. OVERSIZE PART DIMENSIONS FOR GASOLINE AND DIESEL MODELS

SERIES	PISTON INCLUDING STANDARD PIN					PISTON RING SET					INTAKE VALVE INSERT (STD. STEEL)					EXHAUST VALVE INSERT (STD. STEEL)					INTAKE VALVE INSERT (HARD ALLOY)					EXHAUST VALVE INSERT (HARD ALLOY)					VALVE GUIDES					VALVE TAPPET									
	005 (0.13)	020 (0.25)	020 (0.51)	030 (0.78)	040 (1.02)	005 (0.13)	010 (0.25)	020 (0.51)	030 (0.78)	040 (1.02)	005 (0.13)	010 (0.25)	020 (0.51)	030 (0.78)	040 (1.02)	005 (0.13)	010 (0.25)	020 (0.51)	030 (0.78)	040 (1.02)	005 (0.13)	010 (0.25)	020 (0.51)	030 (0.78)	040 (1.02)	005 (0.13)	010 (0.25)	020 (0.51)	030 (0.78)	040 (1.02)	005 (0.13)	010 (0.25)	020 (0.51)	030 (0.78)	040 (1.02)	005 (0.13)	010 (0.25)	020 (0.51)	030 (0.78)	040 (1.02)					
CK	X	X	X	X	X	X	X	X	X	X	X	X	X	X	X	X	X	X	X	X	X	X	X	X	X	X	X	X	X	X	X	X	X	X	X	X	X	X	X	X	X	X	X	X	X
MCCK	X	X	X	X	X	X	X	X	X	X	X	X	X	X	X	X	X	X	X	X	X	X	X	X	X	X	X	X	X	X	X	X	X	X	X	X	X	X	X	X	X	X	X	X	X
AJ	X	X	X	X	X	X	X	X	X	X	X	X	X	X	X	X	X	X	X	X	X	X	X	X	X	X	X	X	X	X	X	X	X	X	X	X	X	X	X	X	X	X	X	X	X
AK	X	X	X	X	X	X	X	X	X	X	X	X	X	X	X	X	X	X	X	X	X	X	X	X	X	X	X	X	X	X	X	X	X	X	X	X	X	X	X	X	X	X	X	X	X
MAJ	X	X	X	X	X	X	X	X	X	X	X	X	X	X	X	X	X	X	X	X	X	X	X	X	X	X	X	X	X	X	X	X	X	X	X	X	X	X	X	X	X	X	X	X	X
LK	X	X	X	X	X	X	X	X	X	X	X	X	X	X	X	X	X	X	X	X	X	X	X	X	X	X	X	X	X	X	X	X	X	X	X	X	X	X	X	X	X	X	X	X	X
LKB	X	X	X	X	X	X	X	X	X	X	X	X	X	X	X	X	X	X	X	X	X	X	X	X	X	X	X	X	X	X	X	X	X	X	X	X	X	X	X	X	X	X	X	X	X
CCK	X	X	X	X	X	X	X	X	X	X	X	X	X	X	X	X	X	X	X	X	X	X	X	X	X	X	X	X	X	X	X	X	X	X	X	X	X	X	X	X	X	X	X	X	X
MCCK	X	X	X	X	X	X	X	X	X	X	X	X	X	X	X	X	X	X	X	X	X	X	X	X	X	X	X	X	X	X	X	X	X	X	X	X	X	X	X	X	X	X	X	X	X
CCKA	X	X	X	X	X	X	X	X	X	X	X	X	X	X	X	X	X	X	X	X	X	X	X	X	X	X	X	X	X	X	X	X	X	X	X	X	X	X	X	X	X	X	X	X	X
CCKB ¹	X	X	X	X	X	X	X	X	X	X	X	X	X	X	X	X	X	X	X	X	X	X	X	X	X	X	X	X	X	X	X	X	X	X	X	X	X	X	X	X	X	X	X	X	X
CCKB ²	X	X	X	X	X	X	X	X	X	X	X	X	X	X	X	X	X	X	X	X	X	X	X	X	X	X	X	X	X	X	X	X	X	X	X	X	X	X	X	X	X	X	X	X	X
BF	X	X	X	X	X	X	X	X	X	X	X	X	X	X	X	X	X	X	X	X	X	X	X	X	X	X	X	X	X	X	X	X	X	X	X	X	X	X	X	X	X	X	X	X	X
NB	X	X	X	X	X	X	X	X	X	X	X	X	X	X	X	X	X	X	X	X	X	X	X	X	X	X	X	X	X	X	X	X	X	X	X	X	X	X	X	X	X	X	X	X	X
NH	X	X	X	X	X	X	X	X	X	X	X	X	X	X	X	X	X	X	X	X	X	X	X	X	X	X	X	X	X	X	X	X	X	X	X	X	X	X	X	X	X	X	X	X	X
NHA	X	X	X	X	X	X	X	X	X	X	X	X	X	X	X	X	X	X	X	X	X	X	X	X	X	X	X	X	X	X	X	X	X	X	X	X	X	X	X	X	X	X	X	X	X
NHB	X	X	X	X	X	X	X	X	X	X	X	X	X	X	X	X	X	X	X	X	X	X	X	X	X	X	X	X	X	X	X	X	X	X	X	X	X	X	X	X	X	X	X	X	X
NHC	X	X	X	X	X	X	X	X	X	X	X	X	X	X	X	X	X	X	X	X	X	X	X	X	X	X	X	X	X	X	X	X	X	X	X	X	X	X	X	X	X	X	X	X	X
JA	X	X	X	X	X	X	X	X	X	X	X	X	X	X	X	X	X	X	X	X	X	X	X	X	X	X	X	X	X	X	X	X	X	X	X	X	X	X	X	X	X	X	X	X	X
MJA	X	X	X	X	X	X	X	X	X	X	X	X	X	X	X	X	X	X	X	X	X	X	X	X	X	X	X	X	X	X	X	X	X	X	X	X	X	X	X	X	X	X	X	X	X
JB	X	X	X	X	X	X	X	X	X	X	X	X	X	X	X	X	X	X	X	X	X	X	X	X	X	X	X	X	X	X	X	X	X	X	X	X	X	X	X	X	X	X	X	X	X
MJB	X	X	X	X	X	X	X	X	X	X	X	X	X	X	X	X	X	X	X	X	X	X	X	X	X	X	X	X	X	X	X	X	X	X	X	X	X	X	X	X	X	X	X	X	X
JC	X	X	X	X	X	X	X	X	X	X	X	X	X	X	X	X	X	X	X	X	X	X	X	X	X	X	X	X	X	X	X	X	X	X	X	X	X	X	X	X	X	X	X	X	X
MJC	X	X	X	X	X	X	X	X	X	X	X	X	X	X	X	X	X	X	X	X	X	X	X	X	X	X	X	X	X	X	X	X	X	X	X	X	X	X	X	X	X	X	X	X	X
RJC	X	X	X	X	X	X	X	X	X	X	X	X	X	X	X	X	X	X	X	X	X	X	X	X	X	X	X	X	X	X	X	X	X	X	X	X	X	X	X	X	X	X	X	X	X
DJA	X	X	X	X	X	X	X	X	X	X	X	X	X	X	X	X	X	X	X	X	X	X	X	X	X	X	X	X	X	X	X	X	X	X	X	X	X	X	X	X	X	X	X	X	X
MDJA	X	X	X	X	X	X	X	X	X	X	X	X	X	X	X	X	X	X	X	X	X	X	X	X	X	X	X	X	X	X	X	X	X	X	X	X	X	X	X	X	X	X	X	X	X
DJB	X	X	X	X	X	X	X	X	X	X	X	X	X	X	X	X	X	X	X	X	X	X	X	X	X	X	X	X	X	X	X	X	X	X	X	X	X	X	X	X	X	X	X	X	X
DJBA	X	X	X	X	X	X	X	X	X	X	X	X	X	X	X	X	X	X	X	X	X	X	X	X	X	X	X	X	X	X	X	X	X	X	X	X	X	X	X	X	X	X	X	X	X
MDJB	X	X	X	X	X	X	X	X	X	X	X	X	X	X	X	X	X	X	X	X	X	X	X	X	X	X	X	X	X	X	X	X	X	X	X	X	X	X	X	X	X	X	X	X	X
MDJE	X	X	X	X	X	X	X	X	X	X	X	X	X	X	X	X	X	X	X	X	X	X	X	X	X	X	X	X	X	X	X	X	X	X	X	X	X	X	X	X	X	X	X	X	X
DJC	X	X	X	X	X	X	X	X	X	X	X	X	X	X	X	X	X	X	X	X	X	X	X	X	X	X	X	X	X	X	X	X	X	X	X	X	X	X	X	X	X	X	X	X	X
MDJC	X	X	X	X	X	X	X	X	X	X	X	X	X	X	X	X	X	X	X	X	X	X	X	X	X	X	X	X	X	X	X	X	X	X	X	X	X	X	X	X	X	X	X	X	X
ROJC	X	X	X	X	X	X	X	X	X	X	X	X	X	X	X	X	X	X	X	X	X	X	X	X	X	X	X	X	X	X	X	X	X	X	X	X	X	X	X	X	X	X	X	X	X
MDJF	X	X	X	X	X	X	X	X	X	X	X	X	X	X	X	X	X	X	X	X	X	X	X	X	X	X	X	X	X	X	X	X	X	X	X	X	X	X	X	X	X	X	X	X	X
ROJF	X	X	X	X	X	X	X	X	X	X	X	X	X	X	X	X	X	X	X	X	X	X	X	X	X	X	X	X	X	X	X	X	X	X	X	X	X	X	X	X	X	X	X	X	X

¹ Some units use alloy as standard
² CCKB industrial engines only
³ CCKB engine penetrator sets
⁴ None used
⁵ Use hard alloy
⁶ Use sinter
 Figures in parentheses 1 indicate equivalent metric (SA) dimension in millimeters

TABLE 4-4. UNDERSIZE PART DIMENSIONS FOR GASOLINE AND DIESEL MODELS

SERIES	MAIN BEARINGS				ROD BEARINGS				KEY
	.002 (0.05)	.010 (0.25)	.020 (0.51)	.030 (0.76)	.002 (0.05)	.010 (0.25)	.020 (0.51)	.030 (0.76)	
AJ	X	X	X	X		X	X	X	1
AK	X	X	X	X		X	X	X	1
MAJ	X	X	X	X		X	X	X	1
CK	X	X	X	X		X	X	X	1
CCK	X	X	X	X		X	X	X	1
CCKA	X	X	X	X		X	X	X	1
LK	X	X	X	X		X	X	X	1
MCK	X	X	X	X		X	X	X	1
CK	X	X	X	X	X	X	X	X	2
LKB	X	X	X	X	X	X	X	X	2
CCK	X	X	X	X	X	X	X	X	2
MCCK	X	X	X	X	X	X	X	X	2
CCKB	X	X	X	X	X	X	X	X	2
BF	X	X	X	X		X	X	X	1
NB	X	X	X	X		X	X	X	1
NH	X	X	X	X	X	X	X	X	2
NHA	X	X	X	X	X	X	X	X	2
NHB	X	X	X	X	X	X	X	X	2
NHC	X	X	X	X	X	X	X	X	2
JA	X	X	X	X	X	X	X	X	2
JB	X	X	X	X	X	X	X	X	2
JC	X	X	X	X	X	X	X	X	2
MJA	X	X	X	X	X	X	X	X	2
MJB	X	X	X	X	X	X	X	X	2
MJC	X	X	X	X	X	X	X	X	2
DJA	X	X	X	X	X	X	X	X	2
DJB	X	X	X	X	X	X	X	X	2
DJBA	X	X	X	X	X	X	X	X	2
DJC	X	X	X	X	X	X	X	X	2
MDJA	X	X	X	X	X	X	X	X	2
MDJB	X	X	X	X	X	X	X	X	2
MDJC	X	X	X	X	X	X	X	X	2
MDJE	X	X	X	X	X	X	X	X	2
MDJF	X	X	X	X	X	X	X	X	2
RDJF	X	X	X	X	X	X	X	X	2
RJC	X	X	X	X	X	X	X	X	2
RDJC	X	X	X	X	X	X	X	X	2

KEY
 1. Aluminum Rod
 2. Forged Rod

Figures in parenthesis () indicate equivalent metric (SI) dimension in millimetres.

GENERAL TORQUE INFORMATION

When servicing Onan equipment, be sure to torque all nuts, bolts and studs according to Table 4-5 and the following information. Two factors to consider when discussing torque are excessive friction and clamping force.

1. Excessive Friction: Friction is a force opposing motion.
2. Clamping Force: Clamping force holds or fastens two or more things together.

Excessive friction can cause decreasing clamping force.

Figure 4-1 shows a cap screw with excessive friction and no clamping force. Figure 4-2 shows a cap screw with good clamping force because of clean, lubricated threads.

Torque Procedure

1. Clean all threads.
2. Lubricate threads with specified lubricant. (Assemble dry if specified.)
3. Hand tighten all bolts.
4. Use the specified pattern (shown in Master Service Manual) for tightening sequence.
5. Tighten bolts to 1/2 the torque value.
6. Repeat pattern bringing all bolts up to full torque value. If no torque pattern is specified, start at center line of gasket and torque bolts as shown in Figure 4-3, following numbered sequence.

CAUTION Cylinder head bolts on "J" series water-cooled units that have been overhauled must be retorqued after 1/2 hours to 2 hours of operation. (Not necessary on new units from factory.)

Cylinder head bolts on "J" series aircooled units must be retorqued to specified torque value after 50 hours of operation. (Back off 1/2 turn and then retighten.)

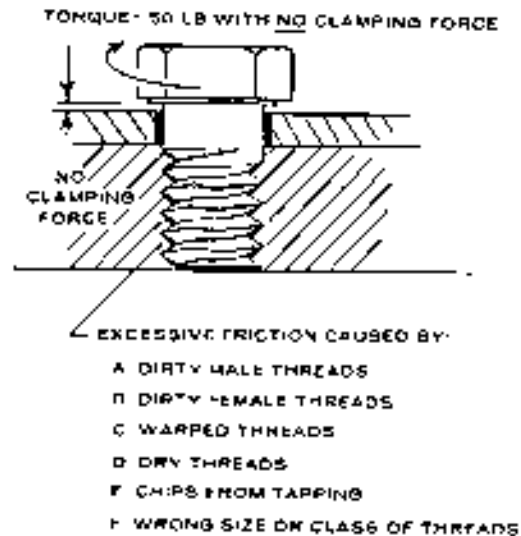

FIGURE 4-1. POOR CLAMPING FORCE

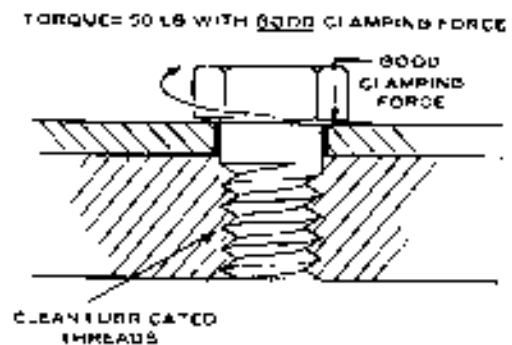

FIGURE 4-2. GOOD CLAMPING FORCE



FIGURE 4-3. BASIC TORQUE PATTERNS

TABLE 4-5. TORQUE SPECIFICATIONS

ENGINE SERIES	Cylinder Head (Code)	Use Engine Lubricating Oil As A Thinner Lubricant				Do Not Use Any Lubricant Or Thinner Than								
		Conn. Rod	Rear Bearing Flange	Main Bearing (4 Cyl)	Pinhead 3rd Crank. Shaft	Oil Base	Crackst Manifested (Pigmen Early)	Inject. Malfunc.	Dampers Plywood Appy. (4 Cyl)	Nocker Arm Stud In Head	Removing Ammunition Uplift	Remolding Field Units	Spark Plug	Injection Nozzle
A2	10-28	10-42	20-25	-	35-40	25-30	-	-	-	25-30	-	-	25-30	-
MAJ	33-35	14-16	27-34	-	47-54	34-41	-	-	-	34-41	-	-	34-41	-
AK	10-28	10-12	20-25	-	30-40	25-30	-	-	-	25-30	-	-	25-30	-
AK	33-35	14-16	27-34	-	47-54	34-41	-	-	-	34-41	-	-	34-41	-
LK	10-28	20-25	20-25	-	35-40	25-30	-	-	-	25-30	-	-	25-30	-
LKB	29-31	20-25	21-24	-	47-54	34-41	-	-	-	34-41	-	-	34-41	-
CKA	29-42	25-30	21-24	-	30-40	25-30	-	-	-	25-30	-	-	25-30	-
CKB	39-42	①	27-34	-	47-54	34-41	-	-	-	47-54	-	-	47-54	-
BP	14-16	14-16	26-27	-	35-40	18-25	-	5-10	-	45-50	-	-	15-20	-
BP	19-22	19-22	34-37	-	47-54	34-41	-	5-14	-	61-68	-	-	20-27	-
NB	28-31	①	30-35	-	30-35	38-43	-	-	-	35-40	-	-	15-20	-
NB	39-42	①	41-47	-	41-47	52-58	-	-	-	35-40	-	-	15-20	-
NH	27-29	27-29	25-27	-	30-35	18-23	-	-	-	35-40	-	-	15-20	-
NH	30-34	30-34	34-37	-	41-47	24-31	-	-	-	45-50	-	-	20-27	-
NHB	17-19	27-29	20-23	-	35-40	18-23	-	10-12	-	15-20	-	-	15-20	-
NHB	23-25	23-25	27-31	-	47-54	34-41	-	14-15	-	15-20	-	-	15-20	-
NHC	17-19	27-29	20-23	-	35-40	18-23	-	10-12	-	15-20	-	-	15-20	-
NHC	23-25	23-25	27-31	-	47-54	34-41	-	14-15	-	15-20	-	-	15-20	-
JA	28-30	27-29	40-45	-	49-56	30-38	-	12-15	-	25-30	-	-	25-30	-
JA	36-41	37-39	54-61	-	65-70	45-50	-	13-15	-	34-41	-	-	34-41	-
JB	28-30	27-29	40-45	-	49-56	30-38	-	12-15	-	25-30	-	-	25-30	-
JB	36-41	37-39	54-61	-	65-70	45-50	-	13-15	-	34-41	-	-	34-41	-
JC	28-30	27-29	40-45	-	49-56	30-38	-	12-15	-	25-30	-	-	25-30	-
JC	36-41	37-39	54-61	-	65-70	45-50	-	13-15	-	34-41	-	-	34-41	-
MAA	44-46	27-29	40-45	-	49-56	30-38	-	12-15	-	25-30	-	-	25-30	-
MAA	50-52	37-39	54-61	-	65-70	45-50	-	13-15	-	34-41	-	-	34-41	-
MIB	44-46	27-29	40-45	-	49-56	30-38	-	12-15	-	25-30	-	-	25-30	-
MIB	50-52	37-39	54-61	-	65-70	45-50	-	13-15	-	34-41	-	-	34-41	-
MAJ	44-46	27-29	40-45	-	49-56	30-38	-	12-15	-	25-30	-	-	25-30	-
MAJ	50-52	37-39	54-61	-	65-70	45-50	-	13-15	-	34-41	-	-	34-41	-
MIDA	44-46	27-29	40-45	-	49-56	30-38	-	12-15	-	25-30	-	-	25-30	-
MIDA	50-52	37-39	54-61	-	65-70	45-50	-	13-15	-	34-41	-	-	34-41	-
DJA	44-46	27-29	40-45	-	49-56	30-38	-	12-15	-	25-30	-	-	25-30	-
DJA	50-52	37-39	54-61	-	65-70	45-50	-	13-15	-	34-41	-	-	34-41	-
MIDJA	44-46	27-29	40-45	-	49-56	30-38	-	12-15	-	25-30	-	-	25-30	-
MIDJA	50-52	37-39	54-61	-	65-70	45-50	-	13-15	-	34-41	-	-	34-41	-
DAB	44-46	27-29	40-45	-	49-56	30-38	-	12-15	-	25-30	-	-	25-30	-
DAB	50-52	37-39	54-61	-	65-70	45-50	-	13-15	-	34-41	-	-	34-41	-
MDJA	44-46	27-29	40-45	-	49-56	30-38	-	12-15	-	25-30	-	-	25-30	-
MDJA	50-52	37-39	54-61	-	65-70	45-50	-	13-15	-	34-41	-	-	34-41	-
MIDJC	44-46	27-29	40-45	-	49-56	30-38	-	12-15	-	25-30	-	-	25-30	-
MIDJC	50-52	37-39	54-61	-	65-70	45-50	-	13-15	-	34-41	-	-	34-41	-
DJC	44-46	27-29	40-45	-	49-56	30-38	-	12-15	-	25-30	-	-	25-30	-
DJC	50-52	37-39	54-61	-	65-70	45-50	-	13-15	-	34-41	-	-	34-41	-
MIDJF	44-46	27-29	40-45	-	49-56	30-38	-	12-15	-	25-30	-	-	25-30	-
MIDJF	50-52	37-39	54-61	-	65-70	45-50	-	13-15	-	34-41	-	-	34-41	-
RIJ	44-46	27-29	40-45	-	49-56	30-38	-	12-15	-	25-30	-	-	25-30	-
RIJ	50-52	37-39	54-61	-	65-70	45-50	-	13-15	-	34-41	-	-	34-41	-
RDJC	44-46	27-29	40-45	-	49-56	30-38	-	12-15	-	25-30	-	-	25-30	-
RDJC	50-52	37-39	54-61	-	65-70	45-50	-	13-15	-	34-41	-	-	34-41	-
ROJF	44-46	27-29	40-45	-	49-56	30-38	-	12-15	-	25-30	-	-	25-30	-
ROJF	50-52	37-39	54-61	-	65-70	45-50	-	13-15	-	34-41	-	-	34-41	-

① Aluminum rods 24-26 lb (1.133-95 Nmm), forged rods 27-29 (37-39 Nmm)

② Zinc or aluminum wheel. Call iron wheel 40-45 (54-61 Nmm)

FOOTNOTES

- ① See piston measurement illustration Figure 16-7
- ② CCKB .0008 to 0.008 inch (0.15 to 0.20 mm) when 112-01023 piston used.
- ③ Thumb push fit.
- ④ All clearance cold 70°F (21.1°C)
- ⑤ See oversize availability.
- ⑥ CCKR 3.2420 inches (82.35 mm) to 3.2430 inches (82.37 mm)
- ⑦ MCKK .012 inch (0.30 mm).
- ⑧ MJB .014 inch (0.36 mm) Intake, 0.018 inch (0.46 mm) Exhaust
- ⑨ MCKK 2.0015 inch (50.838 mm) to 2.0040 inch (50.900 mm)
- ⑩ Aluminum rod clearance .0020 to .0033 inch (0.050 to 0.084 mm).
- ⑪ Begin Spec P. Prior to Spec P. min. 83 lb. (11.5 N) max. 93 lb. (12.9 N).
- ⑫ Begin Spec P. .249-.245 inch (6.32-6.22 mm) Prior Spec P. .230-.225 inch (5.84-5.72 mm)
One cylinder only, Prior Spec H. .230-.225 inch (5.84-5.72 mm) Begin Spec R.
.249-.245 inch (6.32-6.22 mm).
- ⑬ MJB 1.2580 to 1.2582 inch (31.95 to 31.96 mm).
- ⑭ JB 25° B:C all fuels. All others 35° BTC Gas, 25° BTC Gas
- ⑮ MCKK. Not Applicable
- ⑯ MCKK 130-140 psi (896.0 to 965.0 kPa).
- ⑰ Straight gas after Spec S, 180-200 psi (1241.0 to 1379.0 kPa).
- ⑱ Begin Spec P. Prior to Spec P. (Piston 112-0102C), use .005 to .0007 inch (0.01-0.02 mm)
- ⑲ Begin Spec P. Prior to Spec P. 21° BTC.

SECTION 5. COOLING SYSTEM — AIR

INDEX

GENERAL DESCRIPTION	5-1
PRESSURE COOLING	5-1
Repair	5-1
VACU-FLO COOLING	5-3
Maintenance	5-3
TABLE 5-1. PRESSURE COOLING AIR FLOW AND VENTING	5-1
TABLE 5-2. VACU-FLO AIR FLOW AND VENTING	5-1
TABLE 5-3. MOBILE ELECTRIC PLANT AIR REQUIREMENTS	5-1

GENERAL DESCRIPTION

Onan manufactures air cooled engines ranging in size from one to four cylinders. Two methods of air cooling can be used on these units depending on their intended application. These methods are pressure cooling and Vacu-Flo cooling.

The most conventional of these systems is the pressure cooling one. Vacu-Flo cooling application is required in small compartment locations. Table 5-1 shows the air flow and vent size requirements for pressure cooled units. Tables 5-2 and 5-3 contain similar information for Vacu-Flo and Mobile units.

NOTE: For detailed installation information on air cooled units see Onan Technical Bulletin No. T-029.

NOTE: For detailed installation information on mobile units see Onan Technical Bulletin No. T-012.

TABLE 5-1. PRESSURE COOLING AIR FLOW AND VENTING

MODEL	RPM	AIR (cfm)	PRESSURE INLET VENT (sq ft)	OUTLET VENT* (sq ft)
AJ	1800	138	1	2
AJ	2400	138	1	2
AJ	3600	224	1-1/2	2-1/2
LK	1800	300	1-1/2	2-1/2
CCK	1800	500	2-1/2	5
CCKB	3600	900	5	10
JB	1800	560	3-1/2	7
JC	1800	890	5	10
DJA	1800	440	2-1/2	5
DJB	1800	590	3-1/2	7
DJC	1800	800	5	10
NB	1800	300	1-1/2	2-1/2
NH	1800	570	3-1/2	7

* If duct is used and length is more than 8 feet or if there are more than two 90° bends, use Vacu-Flo cooling.

TABLE 5-2. VACU-FLO AIR FLOW AND VENTING

MODEL	RPM	AIR (cfm)	INLET VENT (sq ft)	OUTLET VENT* (sq ft)
AJ	1800	180	1/4	1/8
AJ	2400	240	1/2	
AJ	3600	370	1/2	
LK	1800	450	1	3/8
CCK	1800	550	1	1/6
JB	1800	610	1-1/3	*1/2
JC	1800	1100	1-3/4	*1
DJB	1800	610	1-1/3	*1/2
NH	1800	650	1	1/4

* Area of outlet duct. When a long duct (over 8 feet) is used, or if there are more than two 90° bends, increase the duct size 50%. Static pressure in duct should not exceed 0.2" water column.

TABLE 5-3. MOBILE ELECTRIC PLANT AIR REQUIREMENTS*

MOBILE SERIES	RPM	AIR DISCHARGE (CU-FT./MIN)	MIN. FREE AIR INLET, NO RESTRICTION (Sq. Inch)
2.5AJ	3600	300	85
2.51 K	1800	450	100
2.7AJ	3600	325	75
4.0CCK	1800	550	120
6.0CCKB	1800	650	120
6.3NH	1800	650	140

* - BF and NH "Power-Driver" models have fixed air inlet and outlet.

NOTE: Allow for air flow restrictions due to elbows in a duct, etc.

PRESSURE COOLING

When a pressure air cooling system is used, blades on the engine flywheel draw air into the front of the engine housing and force it past the engine cylinders. On smaller engines such as the NB, NH and CCK, the air is then exhausted directly to the rear. On the larger J series engines the air is directed over the cylinders and then out the right side of the engine (Figure 5-2). J series engine air outlet systems may use an air duct and optional cold weather shutter assembly to aid in cooling.

The shutter assembly mounts on the engine air outlet at the right side of the cylinder shroud (Figure 5-2). A thermostatic element controls the opening and closing of the shutters, thus limiting air flow when the engine is cold. When the air temperature inside the engine shroud reaches 120°F, the element plunger begins to move outward, opening the shutters. The shutters must be completely open by the time the cooling air temperature reaches 140°F.

NOTE: On early J series models the high temperature cutoff switch mounts on the air shutter assembly.

The shutter opening temperature isn't adjustable. The power element plunger must contact the shutter roll pin at room temperature. To adjust, loosen the power element mounting screws and slide the assembly until it touches the roll pin with the shutter closed (Figure 5-3).

Repair

If the shutter does not open, check the power element for defects, binding of the plunger and the shutter for binding against the housing.

another free manual from www.searctractormanuals.com

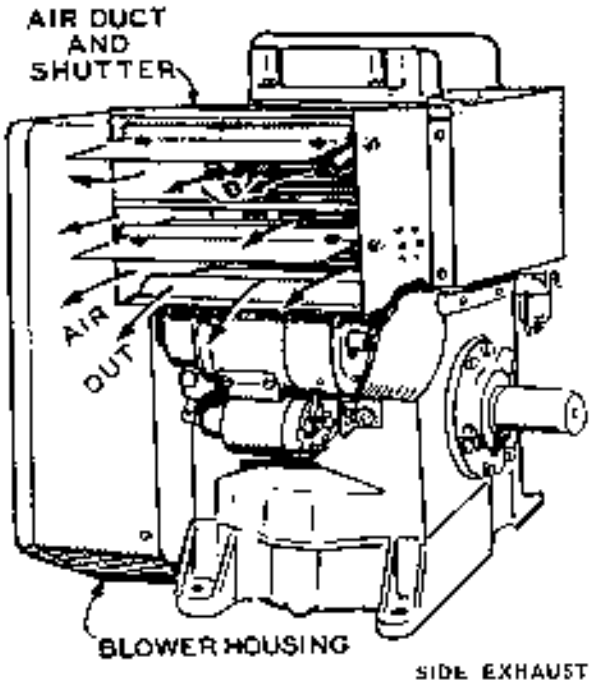
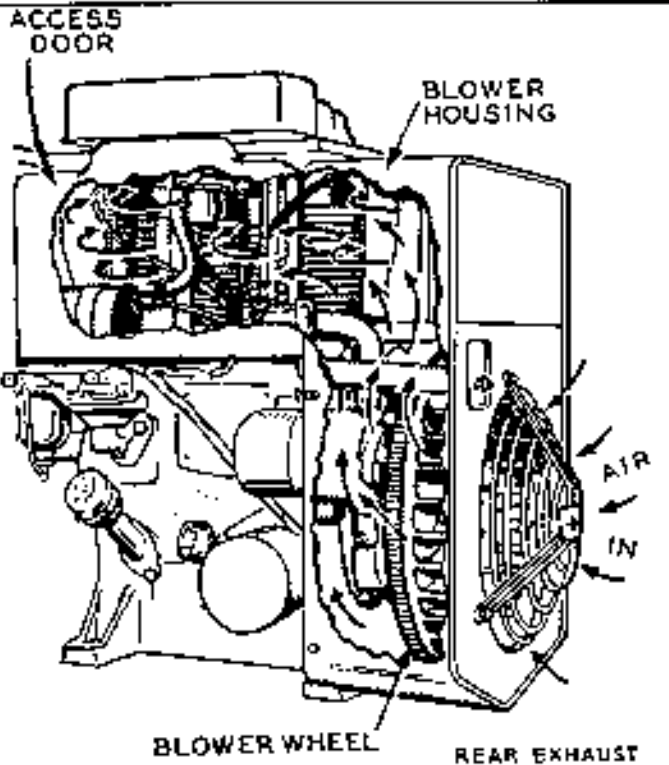
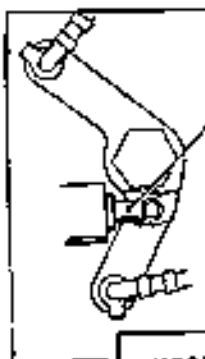
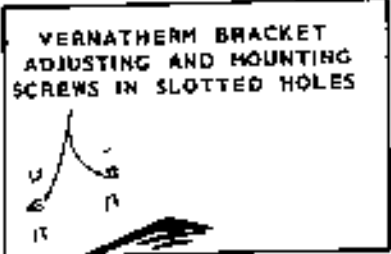

FIGURE 5-1, FIGURE 5-2. PRESSURE COOLED AIR FLOW PATTERN



ADJUST THE VERNATHERM POWER ELEMENT TO REST ON THE ROLL PIN WITH SHUTTER CLOSED AT AMBIENT TEMPERATURE



VERNATHERM BRACKET ADJUSTING AND MOUNTING SCREWS IN SLOTTED HOLES

ADJUST THE VERNATHERM POWER ELEMENT TO REST ON THE ROLL PIN WITH SHUTTER CLOSED AT AMBIENT TEMPERATURE

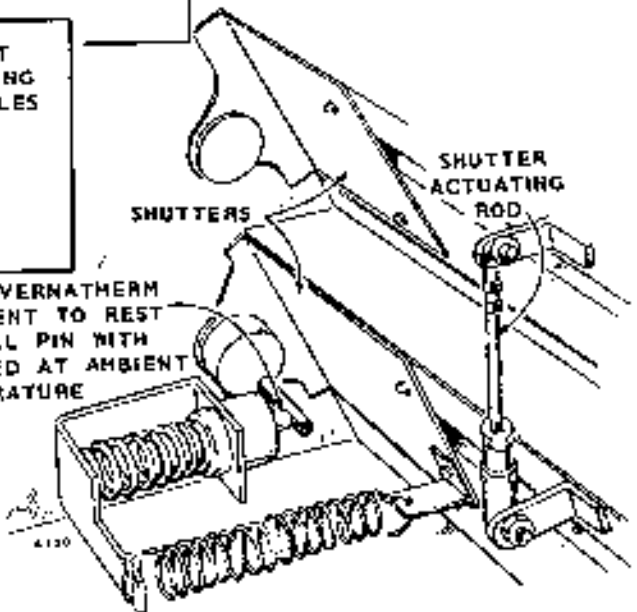

FIGURE 5-3. SHUTTER ASSEMBLY AND MECHANISMS

To test the power element, remove it from the assembly and apply heat. When the element reaches approximately 120°F, the plunger should start to move. Total plunger movement should be at least 13/64 inch.

If the shutter does not close, check for a weak shutter return spring. Binding in the nylon bearings and dirt in the power element plunger can also cause shutter sticking. If the nylon bearings are worn or bind, replace them. Remove the shutters and pull out the stub shafts. Push out the old bearings and push in the new bearings from the inside of the shutter housing. The larger bearing surface acts as a spacer bushing and must be on the inside of the housing.

VACU-FLO COOLING

Vacu-Flo cooling allows operation of industrial engines in a completely enclosed compartment. A centrifugal blower on the engine flywheel (Figure 5-4) pulls cooling air over the cylinder fins and other external engine parts. All heated air is then drawn through the blower duct to the outside. Exhaust from the engine can be vented to the outside separately or through the Vacu-Flo exhaust duct.

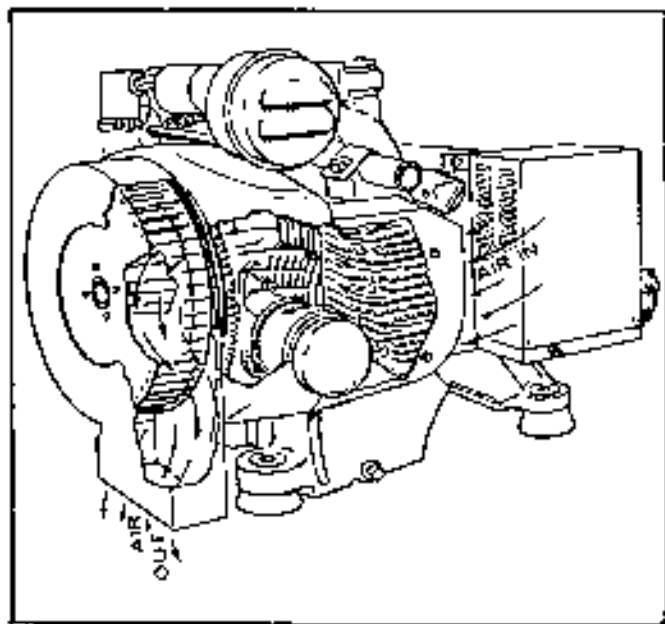

FIGURE 5-4. VACU-FLO COOLING SYSTEM

MAINTENANCE

Keep the engine clean of dust, dirt and grease. Regularly inspect engine cooling fins for accumulated foreign particles. Make sure that the engine exhaust duct is not obstructed.

NOTE: See the Specifications Section of this manual for air intake requirements concerning Vacu-Flo units.

SECTION 6.

COOLING SYSTEM — LIQUID

INDEX

LIQUID COOLED ENGINES	6-1
RADIATOR COOLING SYSTEMS	6-1
Coolant Circulation	6-1
CITY WATER COOLING SYSTEMS	6-2
Standpipe	6-3
Direct Flow	6-3
Wet Manifold-Water Flow	6-3
Bypass Line	6-4
Heat Exchanger Cooling	6-4
Heat Exchangers	6-4
MARINE COOLING SYSTEMS	6-5
J-SERIES COOLING SYSTEMS	6-5
Heat Exchanger	6-6
Skin Cooler	6-6
Plumbing Notes	6-6
Direct Cooling System	6-8
Keel Cooling System	6-8
Keel Cooling Notes	6-9
MCCOOL COOLING SYSTEM	6-10
Direct Cooling	6-10
Heat Exchanger Cooling	6-10
Thermostats	6-12
Raw Water Pump	6-12
MAJ DIRECT COOLING SYSTEM	6-12
Water Pump	6-13
WATER PUMPS	6-16
Raw Water Pumps J-Series	6-16
Disassembly (131-0152)	6-18
Inspection	6-18
Assembly (131-0152)	6-18
Disassembly-Raw Water Pump 131-0115, Heat Exchanger Models MDJF, MDJC, MJA	6-18
Assembly (132-0115)	6-18
Fresh Water Pumps	6-18
Pump Disassembly Heat Exchanger Models (132-0074)	6-19
Pump Assembly	6-19
Rotating Pump Body	6-19
Water Pump Removal - Radiator Models	6-19
WATER PUMP DISASSEMBLY (132-0110)	6-19
HIGH TEMPERATURE CUTOFF SWITCH	6-19
EXPANSION TANKS	6-20
THERMOSTATS	6-20
Testing Thermostats	6-21
ANTIFREEZE	6-21
COOLING SYSTEM MAINTENANCE	6-21
Cleaning	6-22
Draining Cooling System	6-22
Reverse Flushing	6-23
Testing Cooling System	6-23
Repair Notes	6-23
HEAT EXCHANGER KIT INSTALLATION - J-SERIES	6-24
MJB-MDJB Kit No. 130-0194	6-24
MJC, MDJC, MDJF Kit No. 130-0915	6-27
PREPARATION FOR OPERATION	6-30
TESTING	6-30

SIPHON BREAK	6-30
Kit Assembly	6-30
Installation	6-30
COOLING PROBLEMS FROM INTERNAL CORROSION	6-32

LIQUID COOLED ENGINES

Liquid cooled engines built by Onan are adaptable to several cooling systems that circulate the coolant (water or anti-freeze and water mixtures) through the engine water jacket to maintain a uniform operating temperature. Various pumps and controls are used to regulate coolant flow through the engine and its cooling device for best engine performance. The cooling systems discussed in this section are:

- Radiator cooled
- Direct flow or city water cooled
- Standpipe cooling
- Heat exchanger cooling
- Keel or skin cooling (Marine)

The type of cooling system an engine will use is usually determined at the time the unit is purchased, so the factory assembles each industrial engine or electric generating set as a standard model or with the optional equipment ordered. Radiators, pumps, water jacket heaters, water cooled manifolds for use with heat exchangers or city water cooling, coolant filters, flexible water lines and special field conversion kits are available as optional equipment where applicable.

RADIATOR COOLING SYSTEMS

The following models have radiator cooling systems:

- *Generator Sets*—RJC, RDJC, RDJE, RDJF
- *Industrial Engines*—RCCK, RDJE, RDJEA, and RDJF

A radiator is comprised of small finned tubes through which engine coolant passes. These tubes provide a relatively large surface area for transfer of heat from the coolant to the air stream. The air stream in Onan units is produced by a pusher type radiator fan. Cooling air is drawn over the engine and pushed through the radiator, either into a duct or toward the outlet vent. Refer to Table 6-1 for cooling system air flow, radiator area and radiator capacity.

TABLE 6-1. RADIATOR COOLING SYSTEM CAPACITY

UNIT	CAPACITY GALLONS	RADIATOR AREA	AIRFLOW (CFM)
RJC	3 (11.3 litres)	19" x 17" (483 x 432 mm)	2750 (1.28 m ³ /sec)
RDJC RDJF	3 (11.3 litres)	19" x 17" (483 x 432 mm)	2750 (1.29 m ³ /sec)

Adequate ventilation is necessary for radiator cooled models in enclosed areas to prevent recirculation of heated air. Fresh air is required to support combustion in the engine and to cool the engine coolant and the generator cooling air.

If a duct is used to prevent recirculation around the radiator, it should be as large or larger than the open area of the radiator. If no duct is used, the outlet vent area should be twice the area of the radiator and the radiator should be as close as practical to the vent.

CAUTION Do not use antifreeze solutions with an anti-leak formula in cooling systems that have coolant filters. The anti-leak material will clog the filter and prevent normal circulation and cooling.

A thermostat controls the temperature of the cooling system. It mounts in the outlet elbow at the cylinder head water outlet housing.

Coolant Circulation

On radiator cooled models (Figure 6-1), the water pump draws water from the radiator through the bottom hose and forces it into the cylinder water

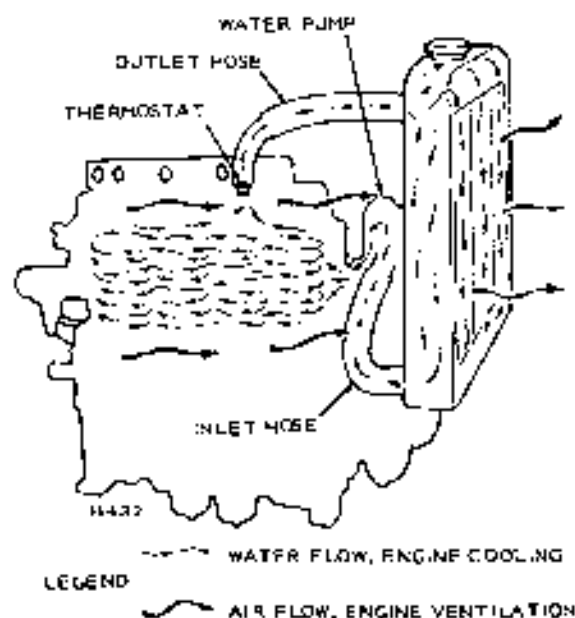

FIGURE 6-1. RADIATOR COOLING SYSTEM

REV. 11-76

jacket at the front of the engine. The water circulates through the cylinder water jacket up through the cylinder heads to the thermostat and flows through the outlet hose into the top of the radiator. It circulates down through the radiator while the fan blows cooling air across the radiator. The water is again drawn from the bottom of the radiator by the pump to be recirculated.

During engine warmup, when the thermostat is closed, the water bypasses the radiator. It flows through a bypass line from the water outlet housing to the pump and recirculates through the engine, until the water reaches normal operating temperature. Recirculation ensures both rapid and even temperature increase of all engine parts during warmup.

Ventilation for radiator cooled models requires an inlet opening for fresh air and an outlet opening for heated air to prevent recirculation of heated air. The openings should be at least the size of the radiator.

CAUTION

An expansion area in the closed cooling system maintains proper coolant level by preventing overflow and loss of coolant when engine heats up.

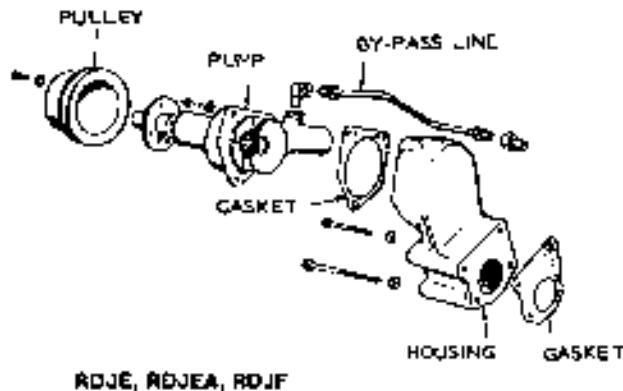

FIGURE 6-2. WATER PUMP—EXPLODED VIEW

The water pump is a centrifugal type with a cast impeller, Figure 6-2. It mounts on the front of the engine cylinder block and is driven by the fan belt from the crankshaft pulley. The inlet to the water pump is from the radiator lower hose. The outlet is through the water pump housing into the cylinder water jacket passages.

The water pump requires no lubrication; the bearings are permanently sealed and packed with a life time lubricant. It requires no maintenance other than bearing replacement if they show excessive looseness, or seal replacement (impeller) if the pump leaks water.

CITY WATER COOLING SYSTEMS

The city water cooling systems do not recirculate water. The cooling water flow rate is regulated and engine cooling is accomplished by means of a standpipe or heat exchanger or by direct flow through the engine water jacket. Either method requires a continuous flow of clean water and a drain for the discharged water.

Pipe sizes, water flow and heat loss requirements are given in Table 6-2. Although classified as "city water" cooling systems, they do not necessarily depend on city water. Any adequate source of clean water may be used. A vacuum relief valve may be used to eliminate the siphoning effect caused by a long discharge line.

For all city water cooled units, Onan recommends the use of water cooled exhaust manifolds (Figure 6-4) to reduce fire hazards and heat emission. With city water cooling there is no fan to provide air circulation; therefore, the units are subject to extreme temperatures at the exhaust manifold.

Check local codes and regulations on city water cooling when planning for a new installation.

TABLE 6-2. HEAT REJECTION TO ROOM (BTU's PER HOUR), PIPE SIZES AND REQUIRED WATER FLOW

ELECTRIC GENERATOR SET	HEAT REJECTION TO ROOM BTU's PER HR. (ENG & GEN)	WATER FLOW (gpm) AND PIPE SIZES (Inch)									
		CITY WATER					HEAT EXCHANGER				
		PIPE SIZE		40°F	60°F	80°F	PIPE SIZE		40°F	60°F	80°F
INLET	OUTLET	INLET	OUTLET								
15.0RDJC	17,570	1/2	3/8	2.3	2.8	3.5	1/2	3/8	2.7	3.6	5.4
17.5RDJF	23,620	1/2	3/8	2.3	2.8	3.5	1/2	3/8	2.7	3.6	5.4
12.5RJJC	25,570	1/2	3/8	2.3	2.8	3.5	1/2	3/8	2.7	3.6	5.4
15.0RJJC	25,570	1/2	3/8	2.3	2.8	3.5	1/2	3/8	2.7	3.6	5.4

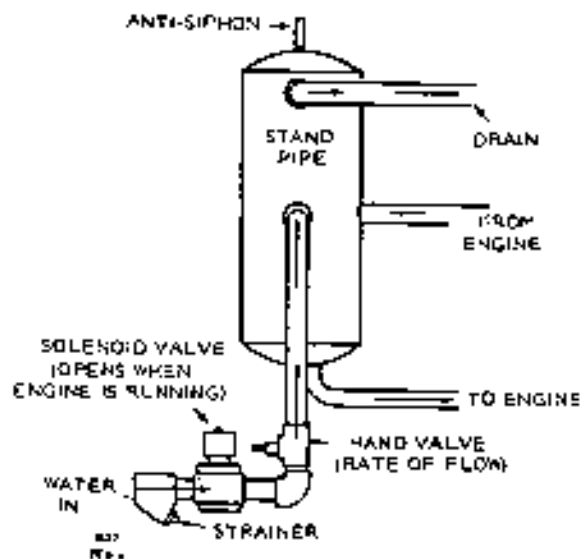

FIGURE 6-3. STANDPIPE COOLING SYSTEM

Standpipe

Water heated during circulation through the engine mixes with fresh "makeup" water in a tempering tank. The hottest water rises and drains from an overflow near the top of the tank. Overflow water is piped to a suitable drain, Figure 6-3.

Rate of flow can be controlled by a hand valve or an automatic valve. A solenoid shutoff valve is coordinated with the unit control system. The hand valve must be adjusted during the initial run to permit only as much water as is needed for adequate cooling to enter the tempering tank at full load.

Direct Flow

This system has no intermediate tank or chamber. City water flows directly to the water jacket of the engine. A constant pressure is needed to force water through the engine to the outlet where it is discharged to a drain.

A solenoid shutoff valve is coordinated with the unit's control system. A supply valve, furnished but not installed, is hand adjusted to control water flow for proper cooling. Care must be exercised to ensure free discharge of cooling water from the engine jacket. Restrictions in the discharge line could cause pressure to build up in the engine water jackets and cause gaskets to leak.

Wet Manifold—Water Flow

On wet manifold, water cooled models (Figure 6-4), the supply valve is manually adjusted for the required minimum rate of water flow for cooling. Whenever the ignition is turned on, the solenoid valve opens the pressurized water inlet line.

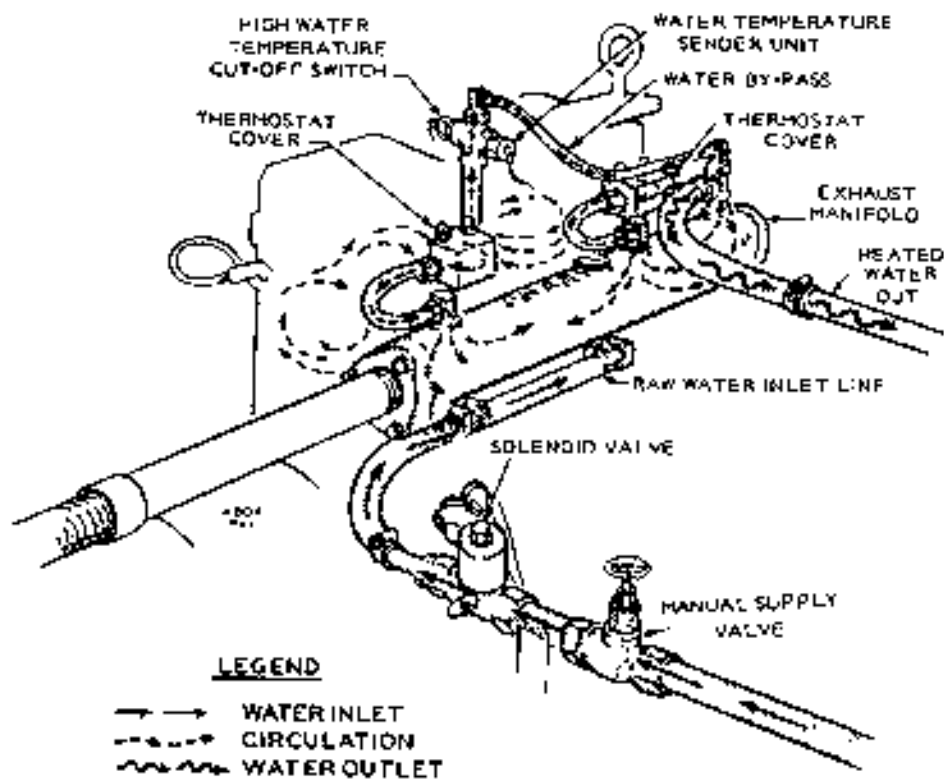

FIGURE 6-4. WET MANIFOLD—COOLING SYSTEM CIRCULATION

During operation, water from the pressurized source flows through the supply valve and solenoid valve and the inlet line and enters at the bottom of the cylinder water jacket at two places, one entry for each pair of cylinders. The water circulates around and up the cylinder jacket through the cylinder heads where it leaves the engine through a thermostat and cover at each of the two cylinder heads. From the thermostat covers, the water passes through the exhaust manifold and is drained from the engine cooling system, Figure 6-5.

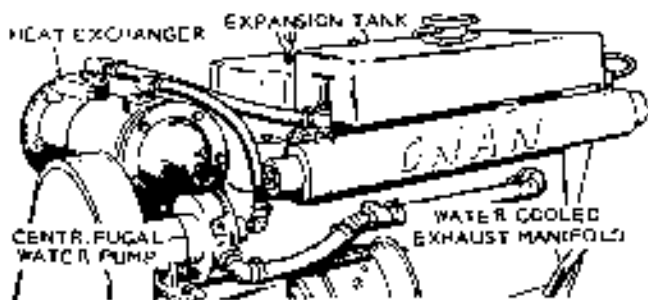

FIGURE 6-5. WATER COOLED EXHAUST MANIFOLD

By-Pass Line

During engine warmup, when the thermostats are closed, a water by-pass line controls the amount of water through the cylinder water jacket until the thermostats open. The by-pass line also functions during operation because it contains the high water temperature cutoff switch and the water temperature sender unit.

Heat Exchanger Cooling

Heat exchanger cooling is available as a factory installed option for all Onan marine electric sets except the MAJ. A heat exchanger kit for field conversion from direct cooling is also available for most Onan marine electric sets except the MAJ.

Heat Exchangers

A heat exchanger consists of a number of tubes encased in a closed chamber. Engine coolant circulates through the shell. Fresh water under pressure is piped through the tubes where it absorbs heat from the engine coolant. Engine coolant is recirculated in its closed system and is not mixed with the city water. Rate of flow is controlled by a hand valve or an automatic valve. A solenoid shutoff valve is coordinated with the unit control system. The hand valve must be adjusted during the initial run to permit only as much water as is needed for adequate cooling to

enter the heat exchanger. Figures 6-6 and 6-7 show a typical heat exchanger and a heat exchanger cooling system.

Onan Heat Exchanger cooling is available either factory installed or as a kit for customer installation. A completed heat exchanger installation contains two

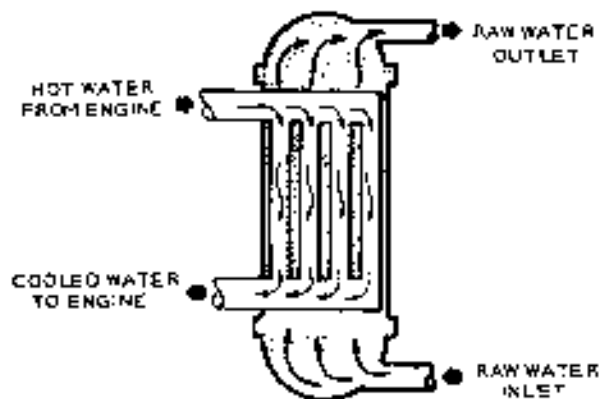

FIGURE 6-6. TYPICAL HEAT EXCHANGER

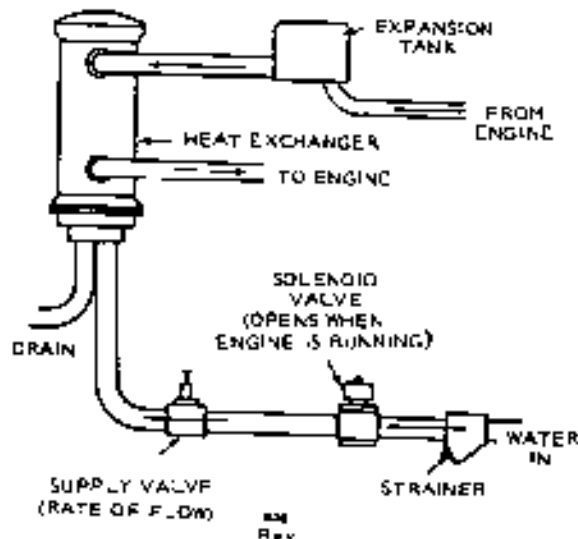

FIGURE 6-7. HEAT EXCHANGER COOLING SYSTEM

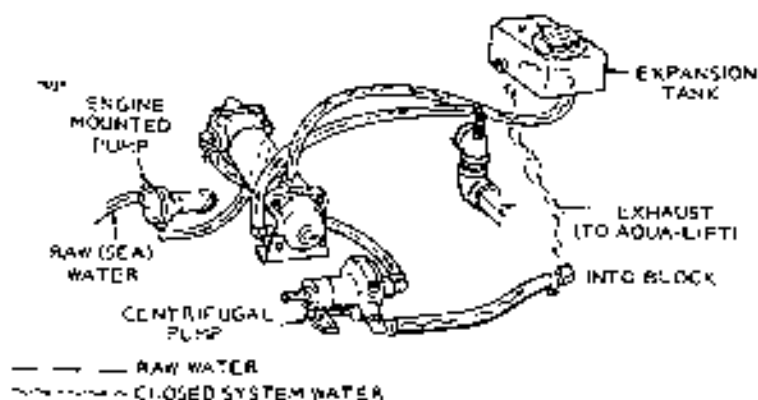

FIGURE 6-8. HEAT EXCHANGER - FRESH AND RAW WATER SYSTEMS.

water systems: the closed water system and raw water system, Figure 6-8. The closed water system continuously recirculates water through the engine water jacket, expansion tank, exhaust manifold, centrifugal pump and one side of the heat exchanger. The raw water system uses the engine mounted, rubber impeller pump to draw sea or city water and circulate it through the heat exchanger, then discharges the water.

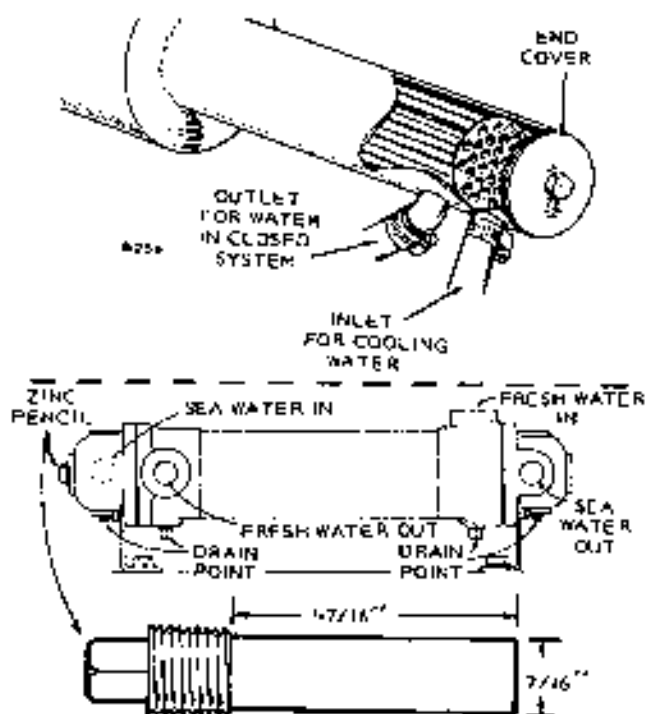

FIGURE 8-9. HEAT EXCHANGER AND ZINC PENCIL

The raw water side of the heat exchanger is protected from corrosion by a zinc pencil mounted on a pipe plug in one end of the heat exchanger. Inspect the pencil at least every two months and replace if deteriorated to less than 1/2 original size, Figure 6-9.

MARINE COOLING SYSTEMS

Three types of marine cooling are in general use today: direct raw water cooling, heat exchanger (fresh water) cooling and keel or skin (fresh water) cooling.

Flotation water drawn into the boat for engine cooling is called raw water. Water recirculating through a closed system is called fresh water.

Direct raw water cooling systems use an engine mounted pump to draw water from the sea and pump it through the engine and out through the exhaust system.

J-SERIES COOLING SYSTEMS

Heat exchangers and keel coolers differ in the method used to cool the fresh water.

The heat exchanger and keel cooler were developed to eliminate raw water flow through the engine cooling jacket and the resulting sediment (salt, silt, etc.) deposits. Both of these systems use fresh water in a closed system to cool the engine. Raw water cools the fresh water in the heat exchanger or keel cooler and the fresh water circulates to the engine water jacket. This system is similar to an automotive radiator—a fixed quantity of fresh water is circulated between engine and cooling device—but differs, because water, not air, cools the engine coolant. Fresh water and raw water never mix so the engine water jacket stays clean.

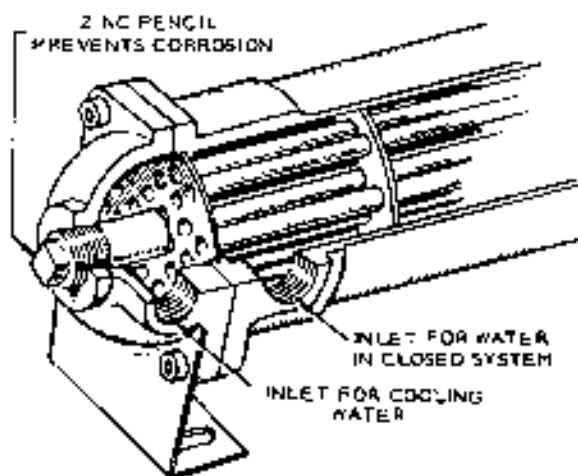

FIGURE 6-10. HEAT EXCHANGER

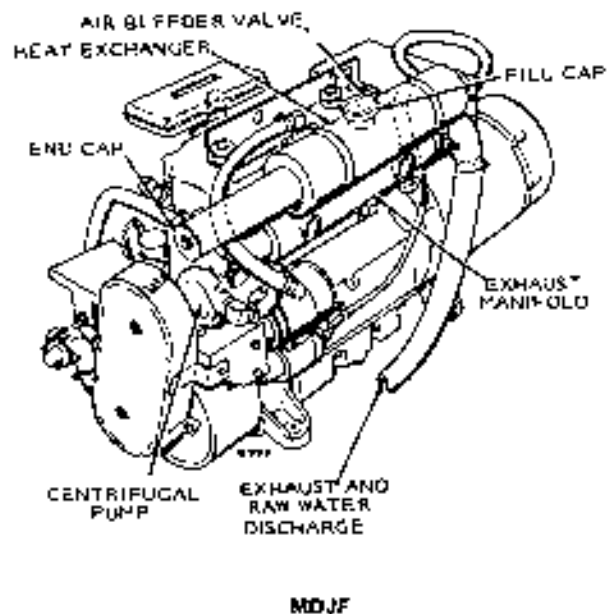
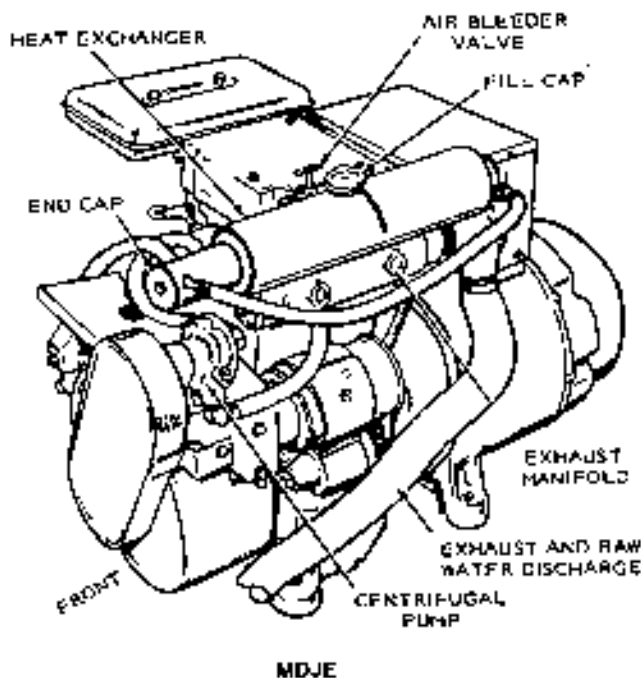

FIGURE 6-11. 2 AND 4 CYLINDER HEAT EXCHANGER COOLING SYSTEMS

Heat Exchanger

A heat exchanger is made of a bundle of tubes with a shell around them, Figure 6-10. Fresh water circulates through the shell and raw water passes through the tubes, so the raw water cools the fresh water. This means there are two separate water systems: a fresh water or closed system circulating water between heat exchanger and engine, and a raw water system circulating raw water through the heat exchanger, Figure 6-11.

Skin Cooler

The skin cooling method uses a section of the hull with an extra skin as a cooling tank. The fresh water passes between the hull and the external skin to be cooled. The engine pumps the heated fresh water through pipes to the skin where it is cooled by the flotation water. Raw water still enters the vessel to cool the exhaust system. A raw water inlet and pump supply cooling water to the exhaust manifold.

Each of the above cooling systems has its own advantages and disadvantages.

CAUTION When planning to install any brand of heat exchanger or any keel cooler, consult the factory or an Onan distributor. To ensure an adequate installation, the engine cooling system must be modified.

If the boat is used extensively in water where a strainer can't remove most of the dirt, install a centrifugal pump and filter below the water line. Dirty water can still plug the block, if direct cooling is used. Heat exchanger, keel cooling or skin cooling should be used under these conditions.

Plumbing Notes

- To cool the unit properly under all conditions, the plumbing must be properly planned and executed. Excess plumbing lengths increase flow resistance and reduce cooling. Air leaks in the water system reduce cooling, cause corrosion and can even destroy a rubber impeller pump. The neoprene impeller pump should never be run dry and should be primed during the initial start and at the beginning of each season.
- See Table 6-3 for cooling system requirements concerning Onan marine generating sets.
- Use water lines of the proper size, following recommendations in Table 6-4. Increase the line size for runs over five feet in length.
- Water lines can be either copper tubing or flexible hose. In any case, use a section of flexible hose on the water inlet next to the set. Use another section on the water outlet, before it enters the exhaust line. This flexible section must be long enough to eliminate engine vibration.
- Unless the raw water is very clean, Onan recommends using a water filter near the water line inlet to protect the cooling system.
- Don't install the water inlet for the set directly in line with other water inlets. This could reduce the amount of raw water received by the engine and cause it to overheat when the boat is underway. Stagger the water inlets. Always use a flush type thru-hull water inlet when using an Aquatift marine muffler with an electric set.

REV. 11-76

TABLE 6-3. ONAN MARINE ELECTRIC SET COOLING REQUIREMENTS AT 1800 RPM RATED LOAD

MODEL	KW RATING (MARINE DUTY)	BORE (IN.)	STROKE (IN.)	MINIMUM ENGINE WATER FLOW (GPM)		PRESSURE DROP ACROSS ENGINE & MANIFOLD AT 1800 RPM & RECOMMENDED FLOW (INCHES OF MERCURY)		TEMPERATURE RISE * (°F) AT RATED WATER FLOW & RATED LOAD (INCLUDES MANIFOLD)		HEAT EXCHANGER COOLING AVAILABLE FROM ONAN	COOLING SYSTEM CAPACITY (PT) WITH HEAT EXCHANGER
				DIRECT COOLING	HEAT EXCHANGER OR KEEL COOLER WATER	DIRECT COOLING	HEAT EXCHANGER COOLING	DIRECT COOLING	HEAT EXCHANGER OR KEEL COOLER WATER		
0.6MAJ (DC)	• 500	2-3/4	2-1/2	.75	†	†	†	†	†	NO	†
1.5MAJ (DC)	• 1,500	2-3/4	2-1/2	.75	†	†	†	-	†	NO	†
2.5MAJ	• 2,500	2-3/4	2-1/2	1.2	†	†	†	†	†	NO	-
4.0MDCK	4,000	3-1/4	3	3.5	3.0	†	†	-	†	YES	7
6.5MCKK	6,500	3-1/4	3	3.5	3.0	†	†	-	†	YES	7
10.0MJC	10,000	3-1/4	3-5/8	4.0	4.7	7.0	9.0	44*	31*	YES	19
15.0MJC	15,000	3-1/4	3-5/8	4.0	4.7	7.0	9.0	44*	31*	YES	19
3.0MDJA	3,000	3-1/4	3-5/8	3.4	3.8	6.75	11.0	13*	10*	YES	4.5
6.0MDJB	6,000	3-1/4	3-5/8	3.6	3.0	3.5	4.75	21*	26*	YES	9
7.5MDJE	7,500	3-1/2	3-5/8	3.8	3.0	13.5	14.75	26*	32*	YES	8
12.0MDJC	12,000	3-1/4	3-5/8	4.0	4.7	7.0	9.0	44*	31*	YES	19
15.0MDJF	15,000	3-1/2	3-5/8	4.0	4.7	7.0	9.0	53*	38*	YES	19

* Engine outlet temperature depends on inlet water and engine but should not exceed 200° F including exhaust manifold for any engine

• Direct current rating

• Rating at 3600 rpm.

TABLE 6-4. COOLING SYSTEM CONNECTING SIZES AND RECOMMENDED HOSE SIZES

GEN SET	INLET THREADED PIPE FITTING SIZE (Inch)	OUTLET THREADED PIPE FITTING SIZE (Inch)	MINIMUM RECOMMENDED HOSE INSIDE DIAMETER (Inch)
MAJ	1/8	1/8	3/8
MJC, MDJA, MDJB, MCKK, MDJE	1/4	3/8 (Hose Adapter Furnished)	1/2
MDJF	3/4	3/8 (Hose Adapter Furnished)	3/4

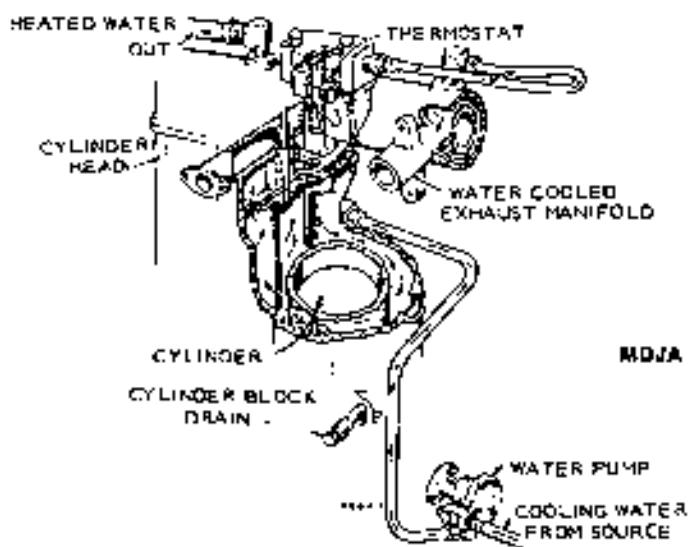
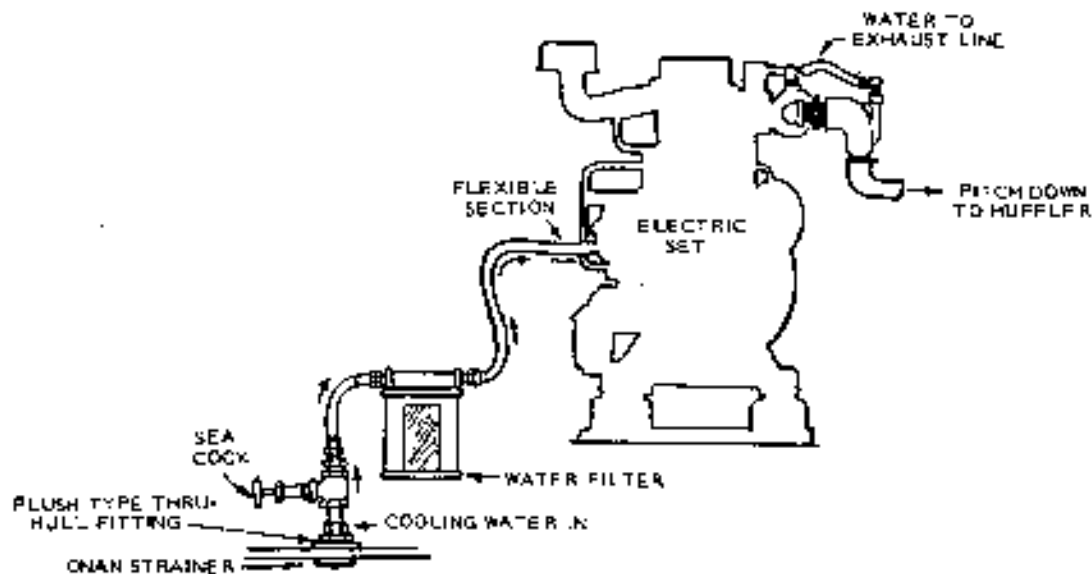

FIGURE 6-12. DIRECT COOLING SYSTEM

Direct Cooling System

The standard cooling system on J-Series electric sets is a pressure circulating, direct cooling open system that uses raw sea water for the coolant. A keel cooler is simply pipes or finned pipes below the vessel's hull, next to the keel.

In a direct raw water cooling system (Figure 6-12), water enters the pump located on the front left side of the engine. The pump delivers the water to the bottom of the cylinder jacket and it flows up the jacket and out an opening in the cylinder head controlled by the thermostat. For engine warm-up, when the thermostat is closed, a by-pass allows water flow from the cylinder block entrance to the thermostat cover. In addition, a notch in the thermostat allows some water flow through the cylinder jacket and heads. From the thermostat, water passes through the water cooled

exhaust manifold and out of the engine cooling system.

When troubleshooting a direct cooling system, check for air leaks and maintain enough water flow to cool the engine.

Keel Cooling System

Onan has available (Figures 6-13 and 6-14) a keel cooler installation for the following sets. MDJA, MDJB, MDJC, MDJE and MDJF. These sets are modified to operate with fresh water keel cooling, an engine mounted neoprene impeller pump to supply raw water exhaust cooling and an engine mounted fresh water pump. The keel cooler, expansion tank and plumbing must be customer supplied. Onan recommends that a keel cooler manufacturer be consulted to select the proper keel cooler model to be used with the generating set.

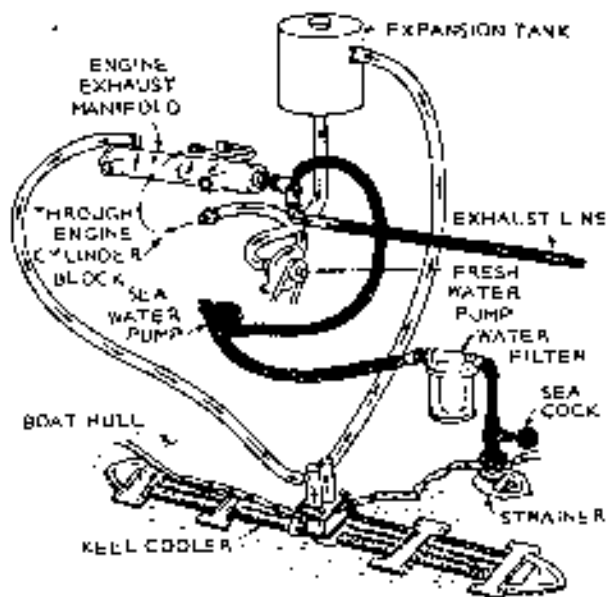

FIGURE 5-13. KEEL COOLING SYSTEM

KEEL COOLING NOTES

1. The electric set often operates at full load when the boat is stopped. The keel cooler should be selected to properly cool the engine at full load when the boat is not underway.
2. The keel cooler should be selected to properly cool the engine at the maximum flotation water temperature the boat will ever encounter. Onan normally suggests a temperature of 85° F (29° C).
3. The keel cooler should be large enough to cool the exhaust manifold.
4. An engine mounted raw water pump is not required with a dry stack exhaust system. The pump should be removed and replaced by a solid plate.
5. For MDJA and MDJB generating sets, 1/2-inch hose should be used throughout the closed water system. The MJC, MDJC, MDJE and MDJF sets use 3/4-inch hose.
6. Onan does not recommend combining the electric set cooling system with the propulsion engine cooling system. This involves a great deal of experience and engineering knowledge as well as complete characteristics of both the electric set and propulsion engines.
7. Change the water filter on keel cooled models after every 100 hours of generator operation. Change sooner if unit is used under exceptionally dirty water conditions.
8. All Onan marine electric sets contain a high temperature shutdown switch that shuts the set down before damage from overheating occurs.
9. A fresh water making system is not recommended unless installed according to the manufacturer's recommendations and the system specifically is designed for the Onan marine electric set.
10. Incorrect plumbing and piping can disrupt the normal cooling system and its capacity.

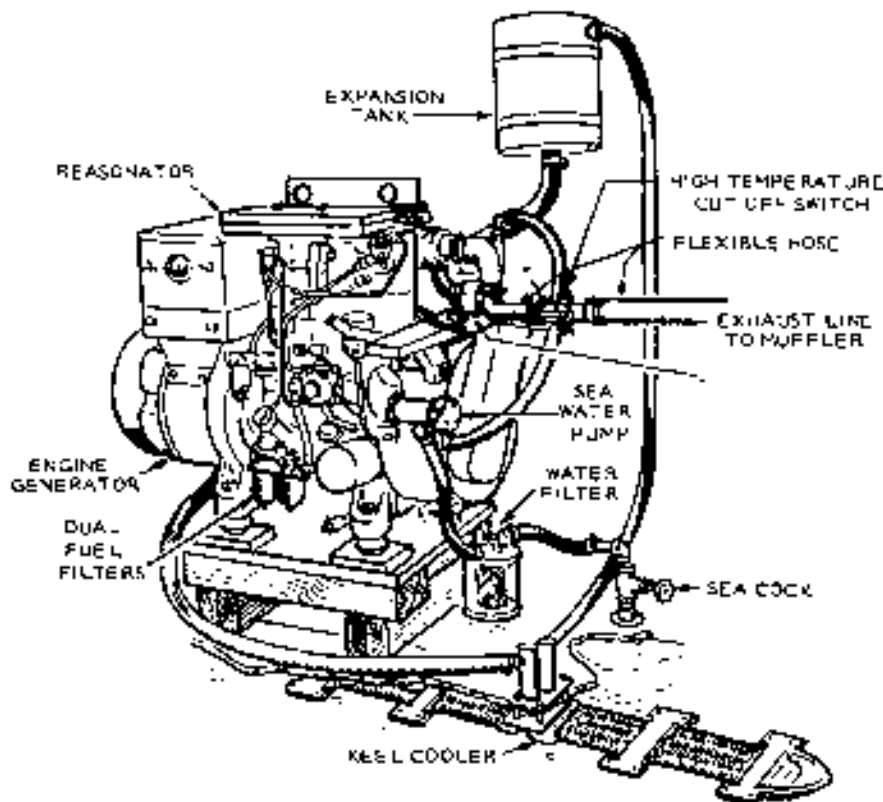

FIGURE 5-14. KEEL COOLING SYSTEM (HEAT EXCHANGER MODELS)

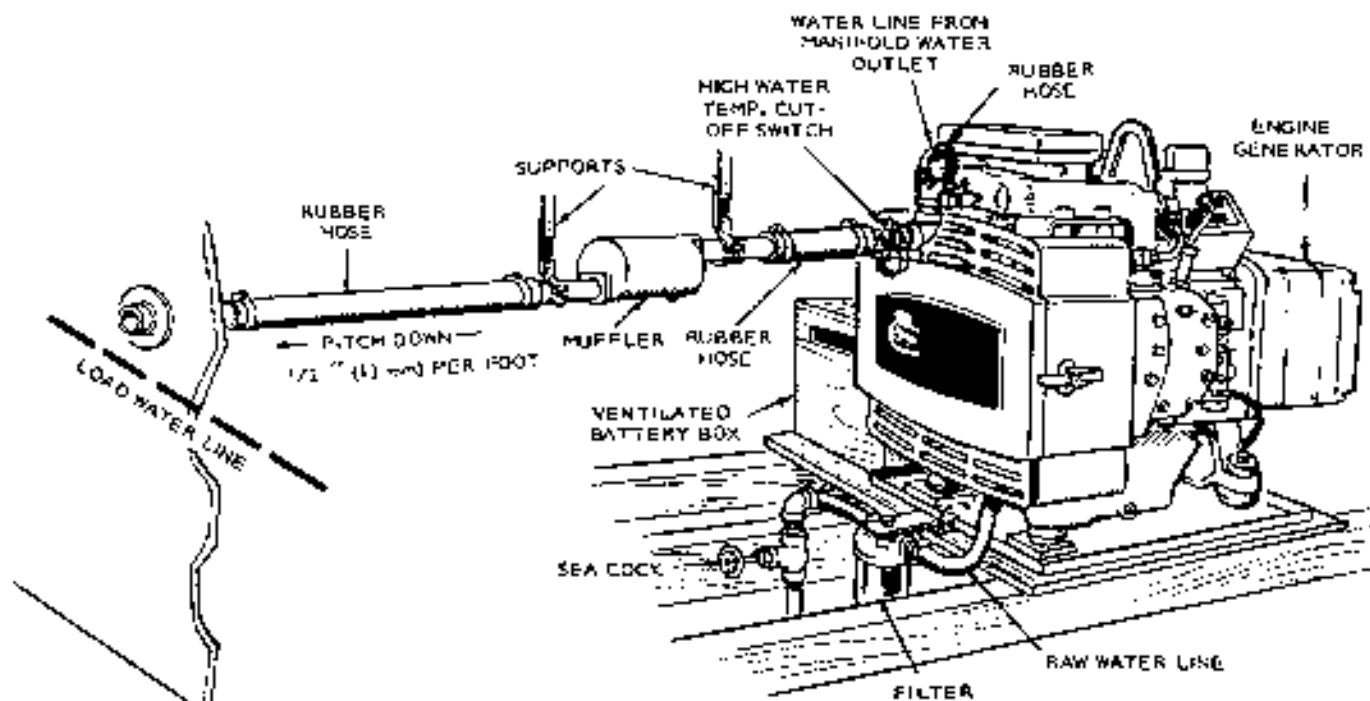

FIGURE 6-15. TYPICAL MCK DIRECT COOLING INSTALLATION

MCK COOLING SYSTEM

The standard MCK cooling system is a pressure circulating, direct type system that uses fresh water or raw water as a coolant.

Factory installed heat exchangers for a closed type system are available as an optional feature.

Direct Cooling

In a raw water cooling system, water enters the pump located on the front right side of the engine. The pump delivers water to the cylinder jacket and it flows through the jacket and out openings in the cylinder heads controlled by thermostats. For engine warmup, with thermostats closed, a by-pass from the cylinder block to the thermostat allows water flow. From the thermostat, water passes through the water cooled exhaust manifold and out the engine exhaust system (Figure 6-15).

Figure 6-16 shows the raw water outlet connection.

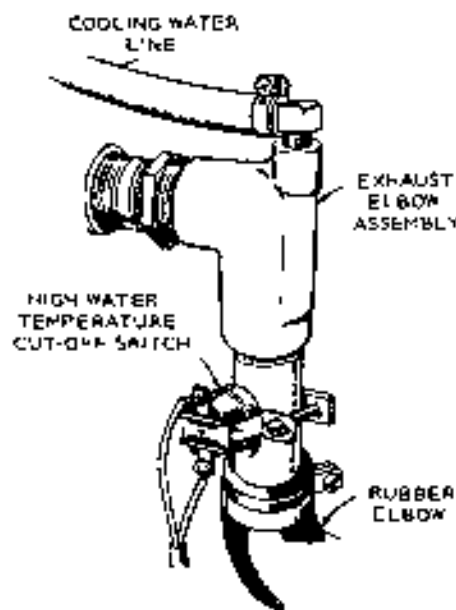

FIGURE 6-16. RAW WATER OUTLET CONNECTIONS

Heat Exchanger Cooling

Onan heat exchangers (Figure 6-17) are available factory installed or as a kit for customer installation. Figure 6-18. A complete heat exchanger installation contains two water systems—a fresh water system and a raw water system. The fresh water system continuously recirculates fresh water through the water jacket, exhaust manifold, centrifugal pump and one side of the heat exchanger. The raw water system uses the engine mounted rubber impeller pump to draw and circulate sea water through the heat exchanger and discharges it into the exhaust line. Figure 6-16.

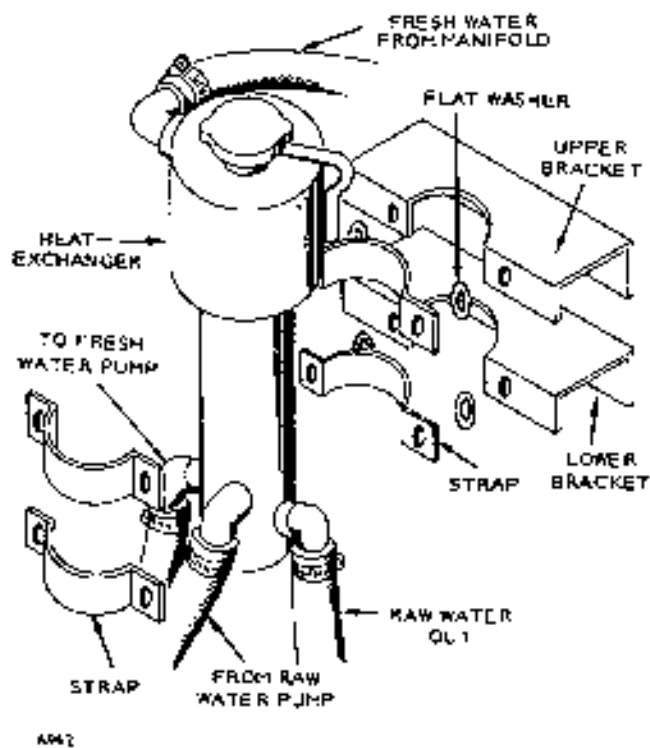

FIGURE 5-17. MOCK HEAT EXCHANGER

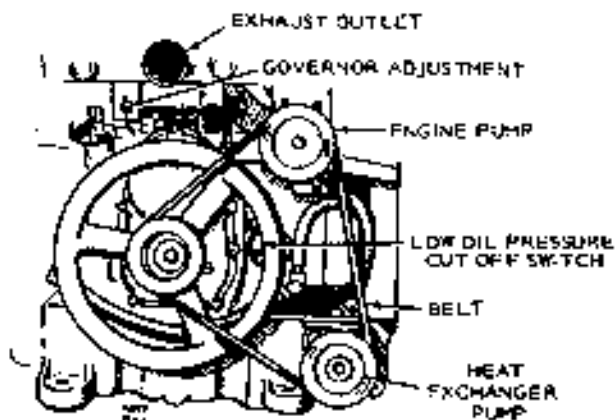
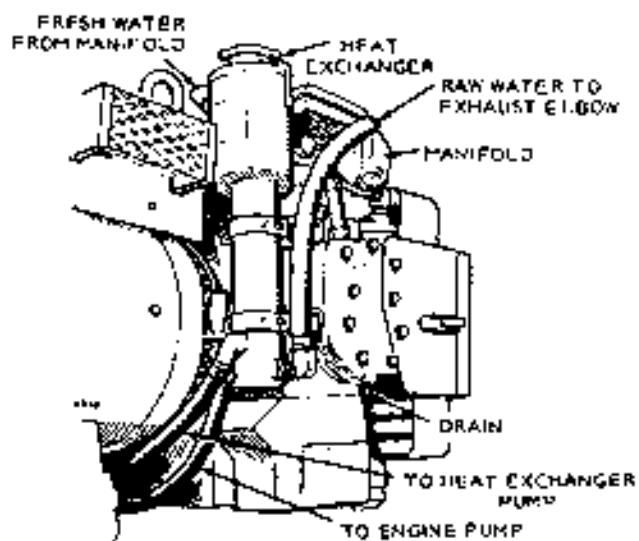
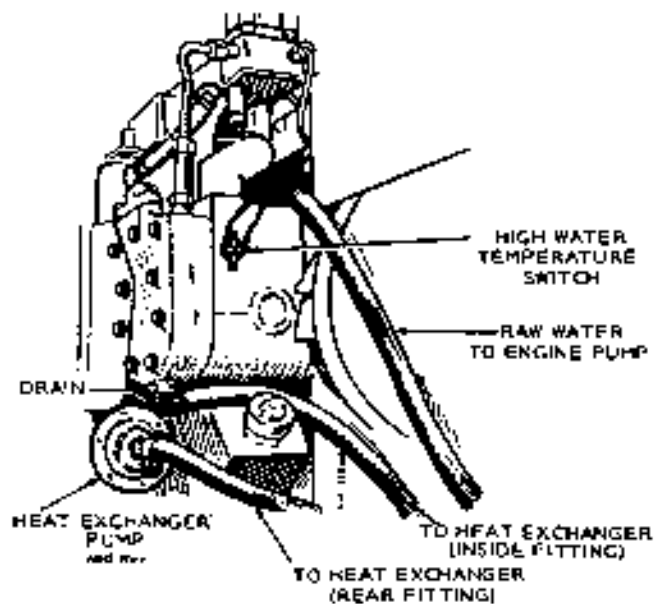

FIGURE 5-18. MOCK HEAT EXCHANGER INSTALLATION

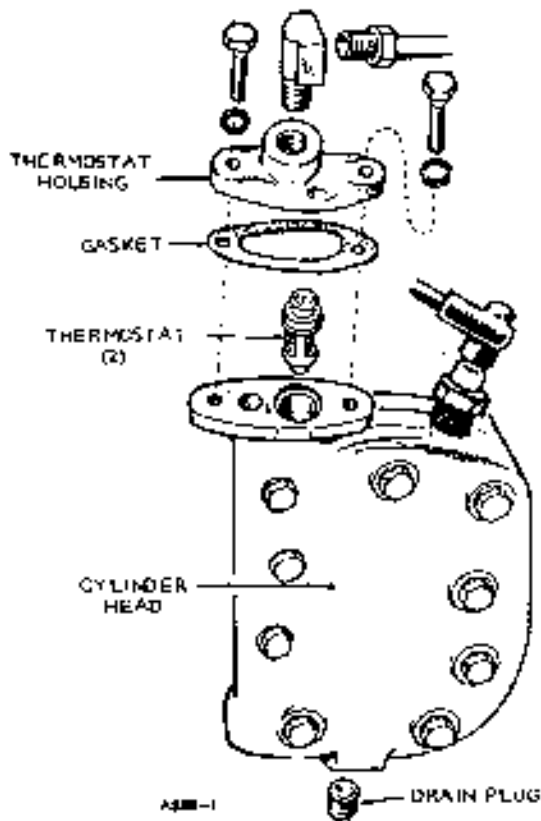

FIGURE 6-19. MCK THERMOSTAT REMOVAL

Thermostats

Thermostats are located on the top of each cylinder head, Figure 6-19. These thermostats are connected by tubing to the water cooled manifold. Replace a thermostat if damaged by corrosion or other causes.

Raw Water Pump

The water pump (Figure 6-20) is a positive displacement, rubber impeller type, located on the upper right corner of the engine. Disassemble pump and repair according to the following instructions.

1. Remove cover and gasket.
2. Remove impeller with pliers or by prying with a pair of screwdrivers, avoiding damage to the pump body. To install a new impeller, align the driving flat surface with the shaft flat surface; bend blades nearest the cam and insert. (Do not remove the factory coating of high-aniline oil from the impeller.)

3. Remove retaining ring. Then pry seal assembly through drain slots. The factory uses *Never Seez* compound to install the bellows seal. This may remain in the pump body. An alternate sealer is suitable, but not necessary. Install with faces clean and oiled.

Use engine lubricating oil on the inside and outside diameter of the seal ring on the new seal before installation. The oil facilitates self-alignment.

4. To remove bearing and shaft assembly, drive it out by striking impeller end of the shaft, using a brass or wood dowel. Install by the same method, striking the drive end of the shaft. If the fit is tight, strike the outer race only. Lubricate the pump bore lightly for ease of assembly.
5. Torque screws 15 to 17 in-lbs (1.7 to 1.92 N*m).

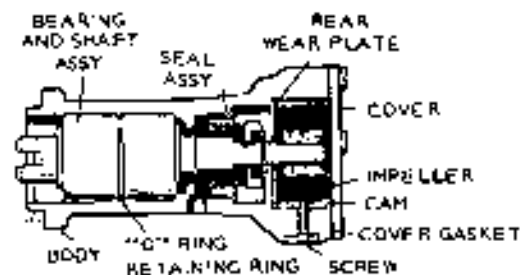
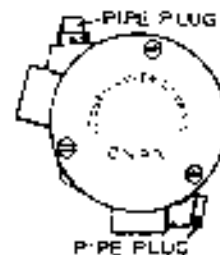

FIGURE 6-20. MCK RAW WATER PUMP



MAJ DIRECT COOLING SYSTEM

The MAJ uses a new water cooled system, Figure 6-21. A water pump impeller circulates cooling water through the engine and discharges it into the exhaust line, ahead of the muffler.

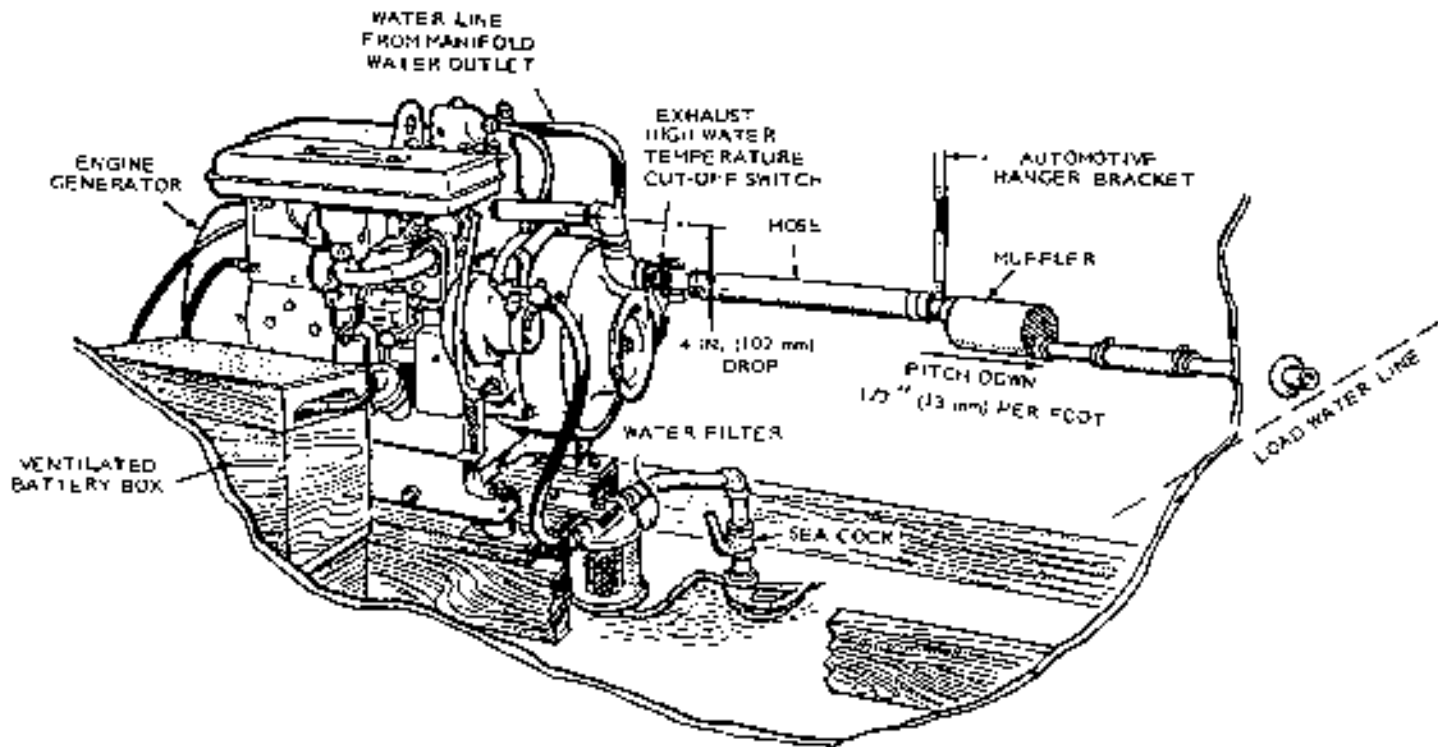

FIGURE 6-21. TYPICAL MAJ GENERATOR SET INSTALLATION

Water Pump

Remove water pump cover (Figure 6-22) and inspect neoprene impeller. If worn or damaged, install new impeller. Pump should discharge a nominal .56 gal/min on 1800 rpm sets or .85 gal/min on 3600 rpm sets when thermostat is open. Install pump cover air tight to prevent early impeller failure. Tighten screws 15 to 17 in-lb (1.7 to 1.9 N*m).

CAUTION The neoprene impeller pump should never be run dry and should be primed for the set's initial start and at the beginning of each season (Figure 6-22).

When replacing water pump, always use Permatex or an approved sealant on all pipe fittings in supply line to water pump. To prove suction line is airtight, see that no bubbles appear in the discharged water. An air leak reduces lubrication and shortens pump impeller life.

Check the strainer in the water suction line for any obstructions which may reduce water flow.

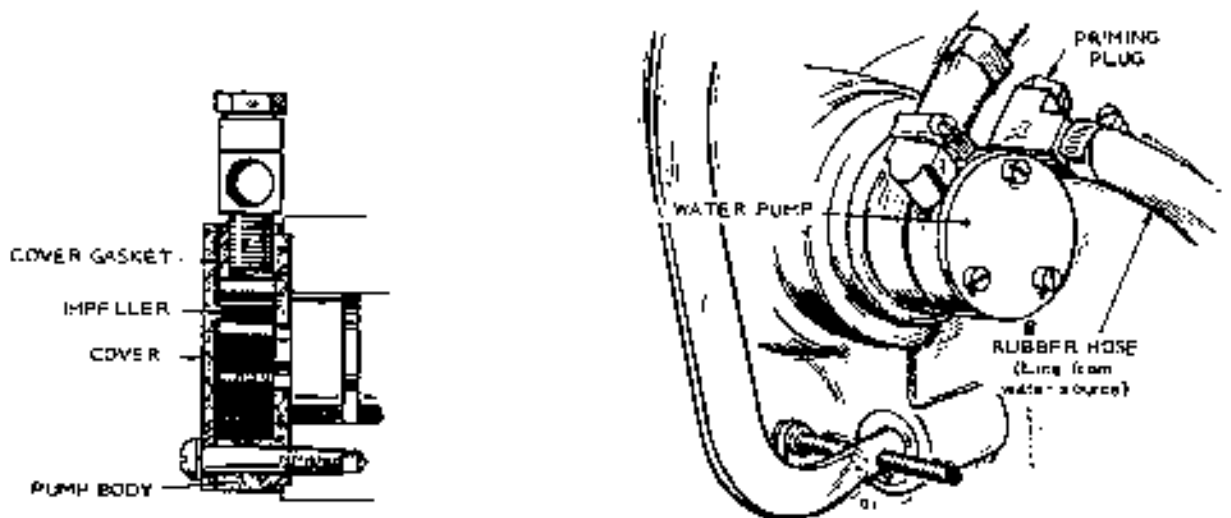
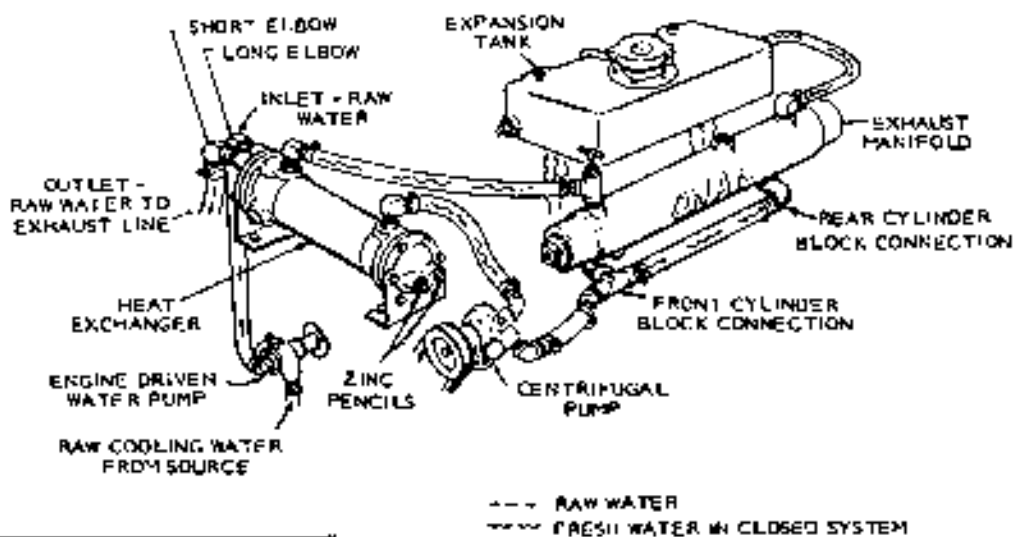
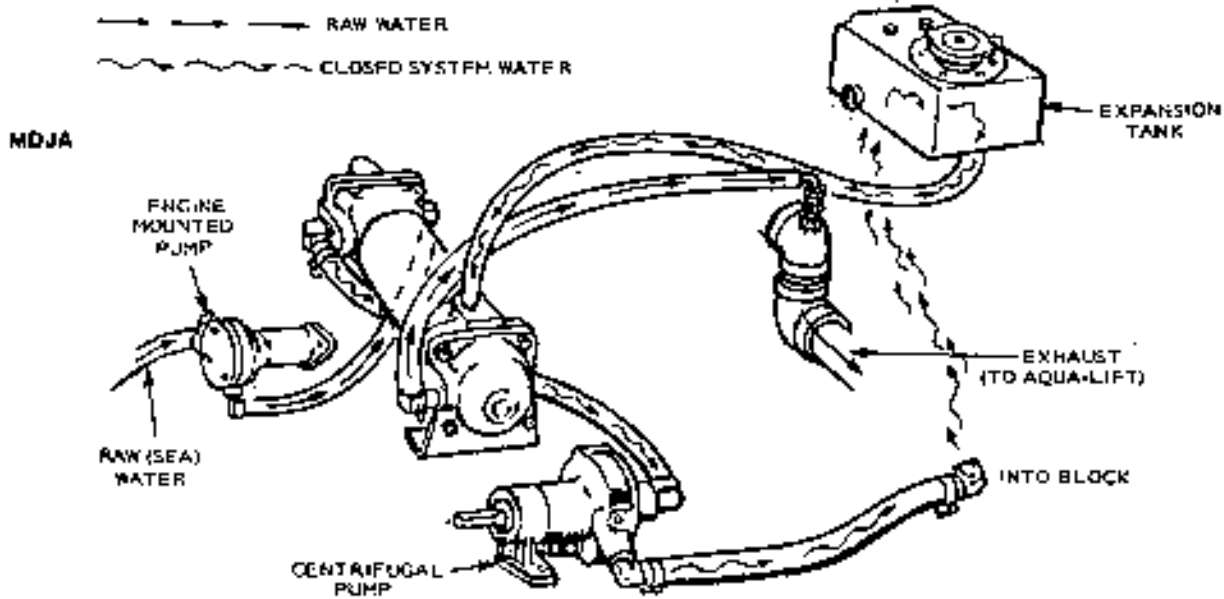

FIGURE 6-22. MAJ WATER PUMP



MDJB, MDJC, MDJE, MDJF

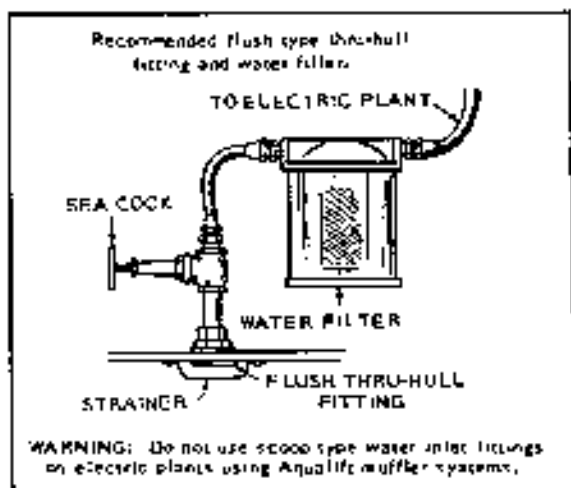
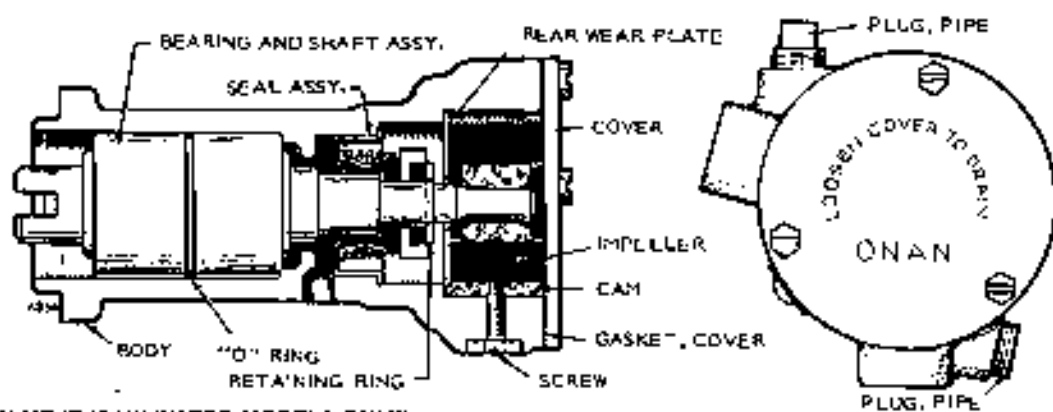

FIGURE 6-23. HEAT EXCHANGER COOLING

REV. 11-76



USED ON MDJF (RAW WATER MODEL 6 ONLY)
 USED ON MDJE (RAW WATER WITH HEAT EXCHANGER)

132-0115 ASSEMBLED

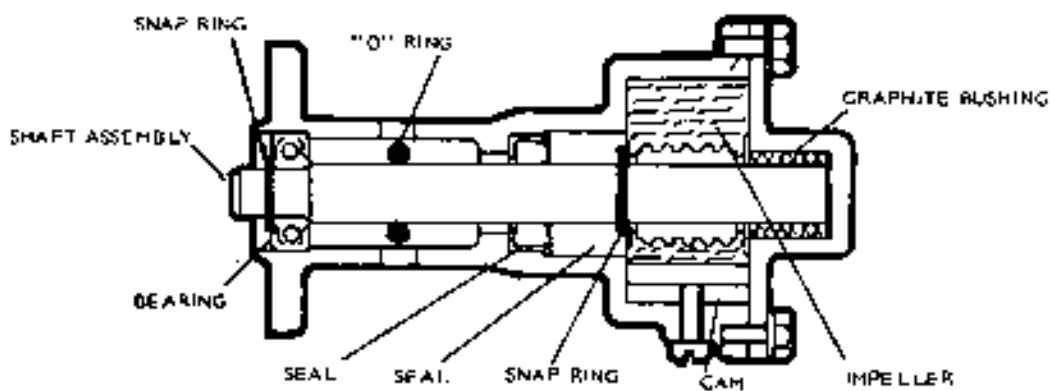

132-0115 DISASSEMBLED

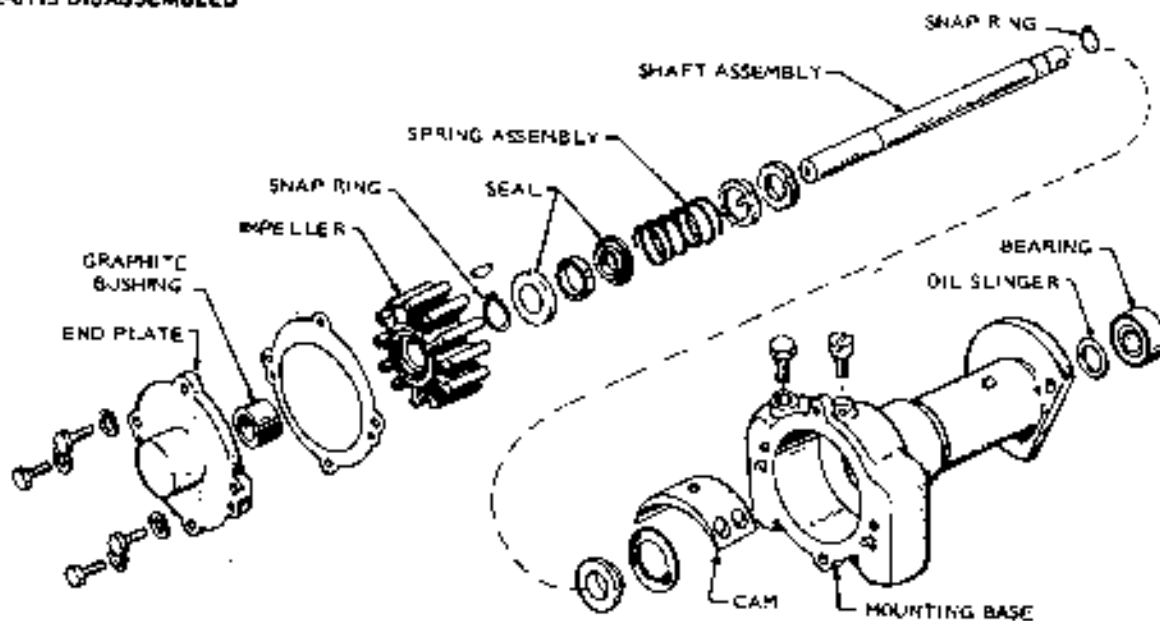

MDJF, MDJC and MJC HEAT EXCHANGER MODELS

FIGURE 6-24. RAW WATER PUMPS

TABLE 6-5. FRESH WATER PUMPS—WITH METAL IMPELLER

132-0110 With Heat Exchanger	132-0074 With Keel Cooler	132-0105 Kil	132-0133
MCCK MDJA for H.E. & K.C. MDJC MDJE MDJF MJB MJC RCCK Ind. Engine RJC RDJC RDJF MCCK OBERDORFER 50P15	MDJE MDJF MDJB MJB MJC MDJC OBERDORFER C10235	RJC Spec A-D RDJC Spec A-C	RDJC Spec D RJC Ind. Engines RDJE Spec A RDJEA Spec A RDJF Spec A WARNER MACHINE CORP. NO. 322CR

TABLE 6-6. RAW WATER PUMPS—WITH NEOPRENE IMPELLER

131-0165	132-0152	132-0115	132-0147	132-0059
MCCK MAJ No Drawing Number ONAN	MDJA Spec E MDJB Spec L MDJC Spec D Without Heat Exchanger MDJE MDJF MJC Without Heat Exchanger Similar to 131-0165	MDJF Before 1976 With Heat Exchanger MDJC Spec AA With Heat Exchanger MJC With Heat Exchanger JABSCO NO. 5850-OM	MDJF With Heat Exchanger Begin 1976 JABSCO	MJB Spec A-K MJC Spec A-C MDJB Spec A-K MDJC Spec A-C — 132-0069 — MDJA to Spec E JABSCO NO. 8790

WATER PUMPS

Two types of water pumps are used on Onan engines: 1) fresh water pumps for closed systems (Table 6-5) and 2) neoprene impeller pumps for the raw water systems (Table 6-6). See Figure 6-23.

Onan raw water cooled marine units use an engine mounted neoprene impeller pump. Because of its sensitivity to hot water, this pump should not be used in closed water systems.

The rubber impeller pumps work well for pumping raw water through direct, heat exchanger, wet manifold, and exhaust cooling systems.

Raw Water Pump (J Series)

The engine mounted raw water pump (Figure 6-24) is located on the upper left corner of the gear cover. Most water pump failures are caused by the neoprene impeller. If the impeller fails, check for pock marks on its end surfaces. This is a sign of air in the cooling system which reduces pump lubrication and causes overheating.

The neoprene impeller, because of continuous flexing, deteriorates with time and must be replaced. If, however, the impeller fails after short service (usually under 500 hours), check for possible defects.

If the pump leaks water along its shaft, replace the water seals (early models) or seal assembly (late models). If the cam, wear plate or end cover show excessive wear, replace them. See Figures 6-24 and 6-25.

another free manual from www.seatractormanuals.com

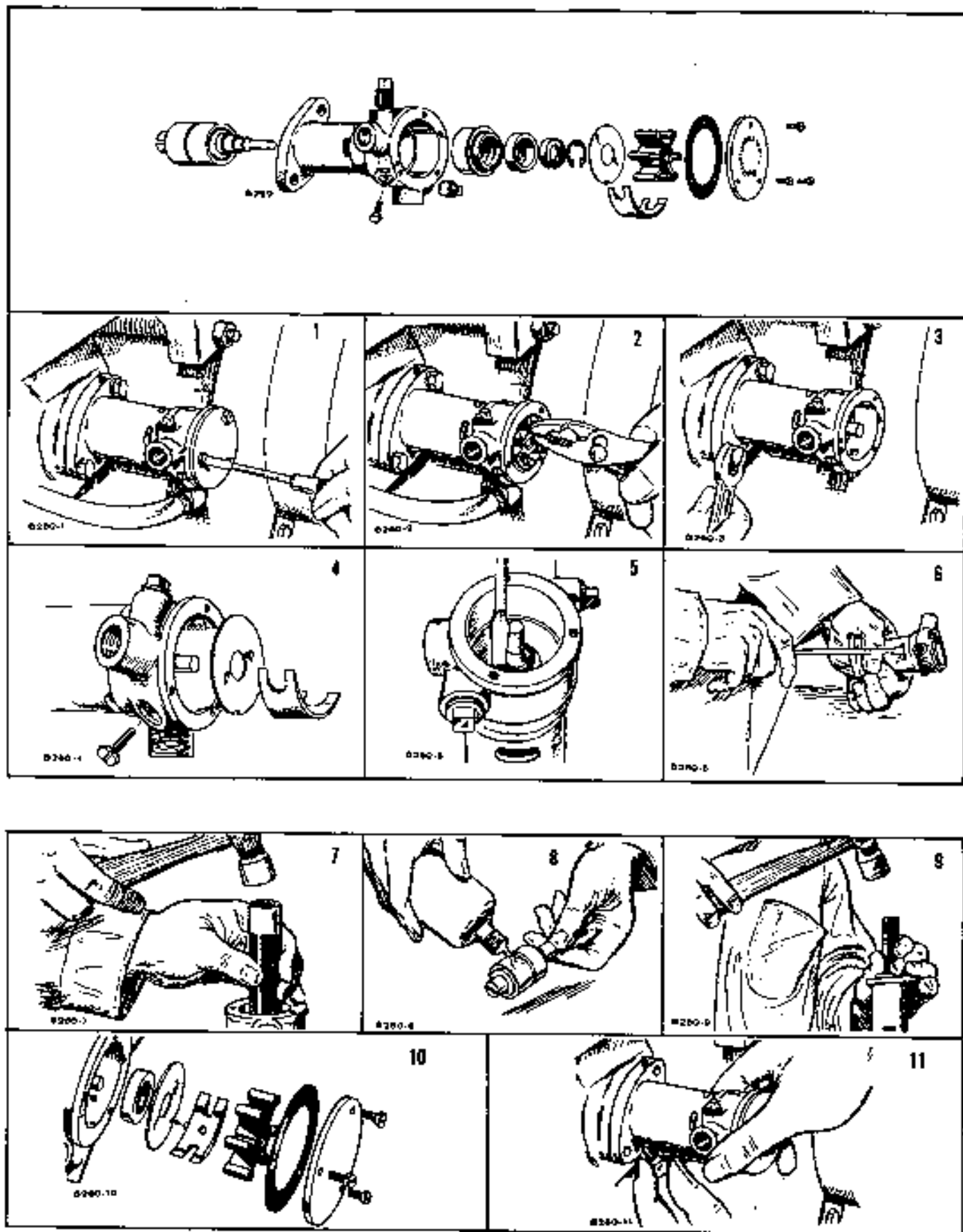

FIGURE 6-25. DISASSEMBLY—RAW WATER PUMP (131-0152)

Disassembly (131-0152)

1. Loosen pump end plate screws and remove end plate. Figure 6-25, step 1.
2. Pull impeller out using a pair of pliers, step 2.
3. If further disassembly is necessary, remove pump from engine by removing two cap screws at its base, step 3.
4. Loosen set screw on side of pump and tap it lightly to free cam from pump body. Lift out cam and wear plate, step 4.
5. Remove snap ring with a screwdriver, step 5. The ceramic seal and O-ring will drop out. Use bearing driver or press to remove bearing and shaft assembly.
6. The bellows assembly can be driven out using a special tool. If tool is not available, pry assembly out by inserting screwdriver through drain slots, step 6.

Inspection

Inspect the housing for wear, rough surfaces or pitting. If any of these conditions exist, discard the housing. Check the bearing housing for leaking grease. By rotating the bearing you can see if it is satisfactory or should be replaced.

Assembly

1. Place bellows in a counter bore and drive in place using special tool, Figure 6-25; step 7.
2. Apply a small amount of Loctite or equivalent on outside diameter of bearing, step 8.
3. Place bearing and shaft assembly in pump bore. Place collar over end of bearing. Drive the bearing in with tool, step 9.
4. Install ceramic seal, rubber seal and snap ring. Place wear plate so groove lines up with tang on cam. Fasten cam to housing with screw provided. Install lubricated impeller, gasket and cover, step 10.
5. Reinstall pump on engine, step 11.

Disassembly—Raw Water Pumps (132-0115) Heat Exchanger Models: Used on MDJF, MDJC, MJA

1. Loosen pump end plate screws and remove end plate
2. Pull impeller out with a pair of pliers or by prying with screwdrivers (avoid damage to body).
3. If further disassembly is necessary, remove pump from engine by removing two capscrews on its mounting base.
4. Remove snap ring from end of shaft.
5. Remove shaft assembly by tapping lightly on drive end of shaft with a brass or wood dowel to avoid damage to shaft.

6. Pull seal and spring assembly off drive end of shaft.
7. Insert drive end of shaft into impeller end of pump. Guide shaft through seal until shaft shoulders against bearing. Tap lightly on shaft with a brass or wood dowel until bearing is out. Also remove oil slinger or O-ring.
8. Insert impeller end of shaft into engine end of pump and guide it through the seal until snap ring shoulders against seal. Tap lightly on shaft until seal is out.
9. The graphite bushing in the end plate may be removed by drilling.

CAUTION Do not drill through the end plate. New bushing may be pressed into the end plate after cleaning.

Assembly (132-0115)

Before beginning assembly, clean all oil sealer from the inside surfaces of the pump body, cam and wear plate. Assembly instructions are reverse of disassembly instructions.

Fresh Water Pumps

The centrifugal fresh water pump is mounted on the heat exchanger bracket. If it should leak, or the bearings require replacement, disassemble it and replace the worn components, Figure 6-26.

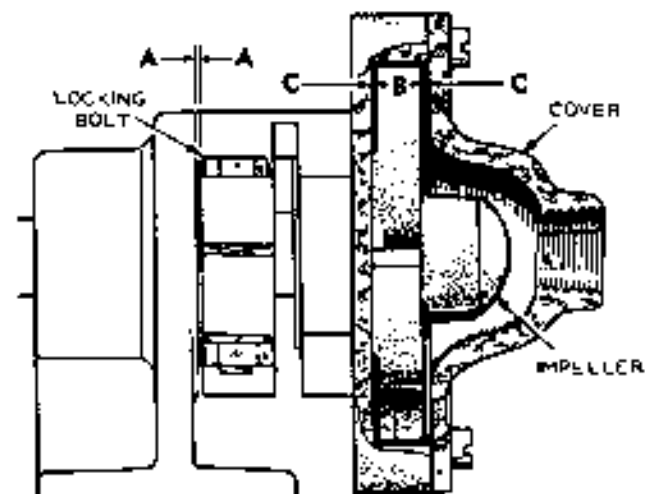

FIGURE 6-26. FRESH WATER PUMP (132-0074)

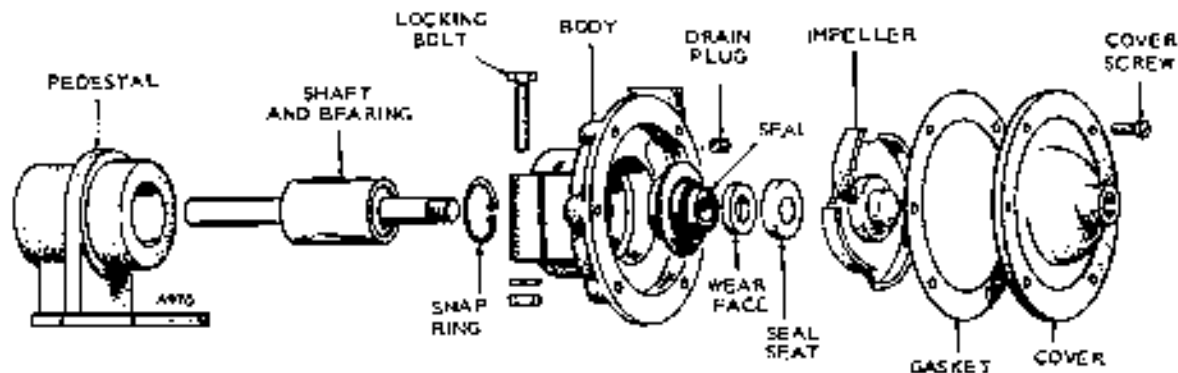

FIGURE 6-27. FRESH WATER PUMP—RJC, RDJC, RDJF, MDJA, MDJB, MDJC, MDJF

Pump Disassembly Heat Exchanger Models (132-0074)

The centrifugal fresh water pump is mounted on the heat exchanger bracket. If it leaks or the bearings require replacement, disassemble as follows and replace the worn components. Refer to Figure 6-27.

1. Remove water inlet from pump and remove six screws holding end cover to pump.
2. Unscrew impeller from shaft counterclockwise when facing impeller.
3. Remove pump body by unscrewing single capscrew that clamps pump body to pedestal.

Replace the worn components. When replacing the water seal, check the wear plate pressed into the impeller and replace it if necessary. To assemble the pump, reverse the disassembly procedure. After assembly rotate pump shaft to see that impeller does not rub on pump body.

4. Remove the retaining ring and drive the bearing assembly out of the pedestal.
5. To remove the water seal, drive it out of the pump body.

Pump Assembly

Replace the worn components. When replacing the water seal, check the wear plate pressed into the impeller and replace it if necessary. To assemble the pump, reverse the disassembly procedure.

The water pump must be reassembled with the proper clearances, or it will overheat and destroy itself. With the drive belt off, the pump pulley must be turned by hand to determine if the impeller is running freely.

Rotating Pump Body

As originally assembled (Figure 6-26), impeller width "B" is centered in body-cover space "C-C." Unless centered, impeller will strike the body or cover. Rotating body will center the impeller in the proper position. Clearance "A-A" can vary from zero to 1/16 inch (1.6 mm).

Water Pump Removal — Radiator Models

1. Drain cooling system at radiator and cylinder block.
2. Remove housing from radiator as necessary.
3. Disconnect both hoses from radiator.
4. Remove radiator.
5. Loosen fan belt.
6. Remove fan and water pump pulley.
7. Disconnect by-pass line and radiator lower hose from pump outlet.
8. Remove water pump from water pump housing, Figure 6-27.
9. Installation is the reverse of removal.

WATER PUMP DISASSEMBLY (132-0110)

1. Place pump in a vertical position with impeller up.
2. Press or drive shaft out front of pump body (out opposite end from impeller). Do not damage impeller casting. The impeller and water seal come off in one integral part. The bearing remains on the shaft; it is a press fit with a seal at each end and is packed with a lifelong lubricant.
3. If bearing is to be removed, the fan hub must be removed. Both are press fitted.
4. Assembly is the reverse of disassembly.

When the fan hub is reinstalled after removal, the distance between the fan and the mounting flange on the pump body must be re-established so the fan belt will be in line.

HIGH TEMPERATURE CUTOFF SWITCH

The high water temperature cutoff switch shuts down the set if cooling water reaches a dangerously high temperature. Besides the impeller, one of the first things to check if this occurs is the thermostat. It is located on the cylinder head and maintains the cooling system temperature at 160°F (71°C).

This normally closed switch senses coolant temperature in the engine cooling jacket, Figure 6-28. When engine temperature rises beyond a specific point the switch opens, breaking the circuit to the coil on gasoline engines or closing the fuel solenoid on diesel engines. When coolant temperature lowers to a safe operating range the switch closes, permitting engine restarting.

See Table 6-7 for high temperature cutoff switch opening and closing temperatures. Part numbers for the switches used on the various liquid cooled units are included in this table.

EXPANSION TANKS

The expansion tank serves as the thermostat housing. To remove the expansion tank, remove the two capscrews extending down through the tank. When installing the tank be sure all connections are tight.

Check the expansion tank fill cap. This is a pressurized cap designed to hold 12-15 psi. The correct cap, good gaskets and smooth gasket surfaces are essential to prevent loss of water.

THERMOSTATS

A thermostat is located on the right side of each cylinder head (Figure 6-29) connected by tubing to the water cooled manifold. Replace the thermostat if damaged by corrosion or other causes.

Check the thermostat opening and closing with a thermometer in a hot water bath. The thermostat should start to open when the water temperature reaches 145° F (63° C).

Repeated stopping and starting of the engine due to action of the high temperature cutoff switch is not a normal condition. Investigate and repair the cause.

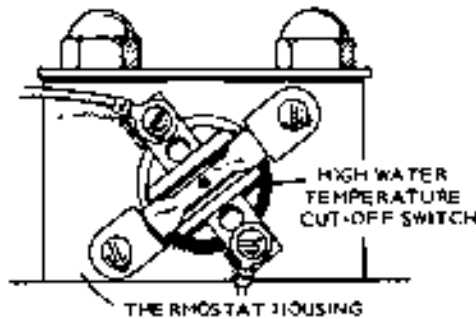
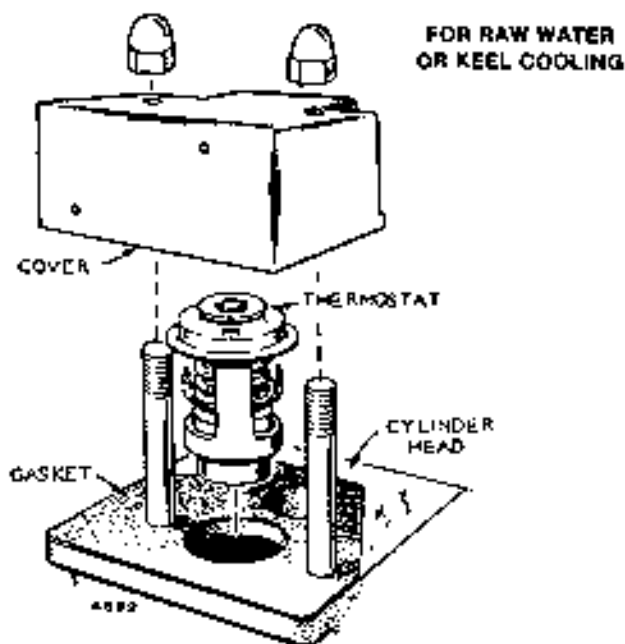

FIGURE 6-28. HIGH TEMPERATURE CUTOFF SWITCH

TABLE 6-7. HIGH TEMPERATURE CUTOFF SWITCH

ENGINE	PART NO.	TEMPERATURE	
		OPENS	CLOSES
MCCK-RCCK	309-0259	230 ± 6 (110° C)	190 ± 9 (88° C)
	309-0252	200 ± 5 (93° C)	160 ± 7 (71° C)
DJC-DJA,DJB	309-0196	375 ± 10 (190° C)	350 (177° C)
	309-0162	240 ± 6 (116° C)	195 ± 8 (91° C)
RDJC	309-0179	190 (88° C)	215 ± 5 (102° C)
RDJF	309-0179	—	—
JC	309-0162	240 ± 6 (116° C)	195 ± 8 (91° C)
JB	309-0196	—	—
MDJF	309-0156	250 ± 5 (121° C)	230 ± 7 (110° C)
MDJE	309-0156	—	—
MDJC	309-0156	—	—
MDJB	309-0156	—	—
MDJA	309-0156	—	—
MDJA	309-0151	200 ± 5 (93° C)	160 ± 7 (71° C)
MDJA	309-0192	290 ± 8 (143° C)	250 ± 12 (121° C)
MAJ	309-0002	160 ± 5 (71° C)	200 ± 7 (93° C)
LK	309-0002	180 ± 5 (71° C)	200 ± 7 (93° C)
DCK	309-0002	160 ± 5 (71° C)	200 ± 7 (93° C)

REV. 11-76



FOR HEAT EXCHANGER COOLING

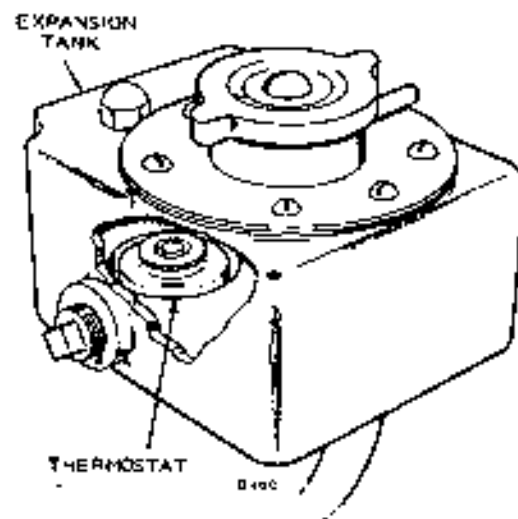

FIGURE 6-29. THERMOSTAT INSTALLATION

Testing Thermostats

The temperature of the cooling system is thermostatically controlled. A thermostat mounts at each cylinder head (two) and is housed in a thermostat cover. Water flows from the thermostat and cover through tubing to the exhaust manifold. If the thermostats become defective, replace them.

Check the thermostat for proper opening and closing; if a sticking or faulty thermostat is suspected, test as follows:

1. Remove thermostat from cylinder head.
2. Heat a pan of water to about 150°F (66°C). Check temperature using a thermometer immersed in water.
3. With thermostat suspended in water at a temperature of 150°F (66°C), thermostat should start to open.
4. After thermostat has opened completely (about 165°F [74°C]), remove it from hot water and allow it to cool in surrounding air. The thermostat should close within a short time.
5. If the thermostat sticks or does not operate properly, replace it with a new one.
6. Always install a new gasket when replacing the thermostat.

ANTI-FREEZE

Corrosion can shorten an engine's life by plugging up radiator cores, building up around hot spots near the exhaust valves, and settling in low areas of the block. The corrosive sediment insulates against proper heat transfer and holds heat in. Most of the metals used in cooling systems are susceptible to corrosion damage that causes coolant leaks and the temperature to rise above safe, normal limits.

Most anti-freeze manufacturers recommend a minimum 50-50 mix of ethylene glycol anti-freeze and water for winter and summer in closed water systems with a complete change every year to avoid corrosion and more extensive damage.

Corrosion inhibitors reduce the formation of rust in a cooling system. Corrosion protection can best be provided in winter by using anti-freeze containing the inhibitor.

PRESSURE CAPS

Pressurized cooling systems run far hotter than the boiling point of water (212°F [100°C]) at atmospheric pressure, so greater breakdown of anti-freeze and water solutions result. The average pressure cap (15 pounds [103.5 kPa]) raises the boiling point of the engine coolant to 265°F (132°C).

Defective pressure caps cause many cooling problems and should be replaced every two years or whenever they malfunction.

COOLING SYSTEM MAINTENANCE

The cooling system including the block and radiator or heat exchanger should be cleaned and flushed at least once a year. This is especially true in cold weather conditions or when preparing unit for extended storage (over 30 days or more).

The cooling system can work efficiently only when it is clean. Scale and rust in the cooling system slow down heat absorption and restrict water flow.

The thermostat is calibrated to open at 150°F ± 2°F (66°C). It should also be checked.

An appropriate anti-freeze mixture should be used in colder climates as necessary.

Water filters should be used in areas where the water is extremely hard and rust inhibitors cannot protect the cooling system from the formation of rust and scale.

Keep the radiator clean to provide maximum cooling. Remove all dirt, lint, etc. Keep the radiator cap closed during operation.

Check the fan belt tension periodically. For proper operation of the water pump, the fan belt should be light enough to prevent slipping.

Check the water pump for wear periodically. Loosen the fan belt and move the fan and water pump pulley back and forth. If wear is excessive, replace the bearing.

Cleaning

To clean the fresh water system, drain and fill with radiator cleaner. When chemical cleaning is done, always flush the cooling system to wash out deposits loosened by the chemical cleaning.

Only a clean cooling system can operate efficiently. Scale slows down heat absorption and restricts water flow. Flush the system at least once a year and more often if operation indicates clogged passages or overheating. To flush the engine, remove the thermostat and the water pump cover. Restrict the pump opening partially so the cylinder block fills with water. Attach the flushing gun nozzle to the thermostat opening and fill the block with water, then apply air pressure. Repeat the process until water coming from the block is clean.

If below freezing temperatures are expected, drain the engine or serious engine damage will result.

Draining Cooling System

The cooling system works efficiently only when it is clean. Scale and rust in the cooling system slows heat absorption and restricts water flow. Clean and flush the system at least once a year and more often if operation indicates clogged passages or overheating. Clean the cooling system with a dependable cleaning compound and follow the procedure recommended by the supplier.

Whenever draining the cooling system for changing anti-freeze solution or for out-of-service protection when only water is used, be sure to open all drains and hose connections where water could be trapped. See Figure 6-30.

The following drain plugs must be removed to allow complete flushing of the cooling system.

Radiator: One petcock lower right front corner.

Engine Block: One drain plug left front near water pump.

Water Pumps: One drain plug under cover or by loosening cover.

If an optional water jacket tank heater is used it should be drained and flushed also. The lower hose must be disconnected at the tank heater. There is no drain plug.

Further information concerning the location and part numbers for the various drain plugs throughout the unit is shown in the *Parts Catalog* for each engine or generator set.

Onan recommends the use of clean ethylene glycol anti-freeze solutions in closed cooling systems during normal operation and storage periods. Be sure anti-freeze solution will protect the cooling system during the coldest winter weather.

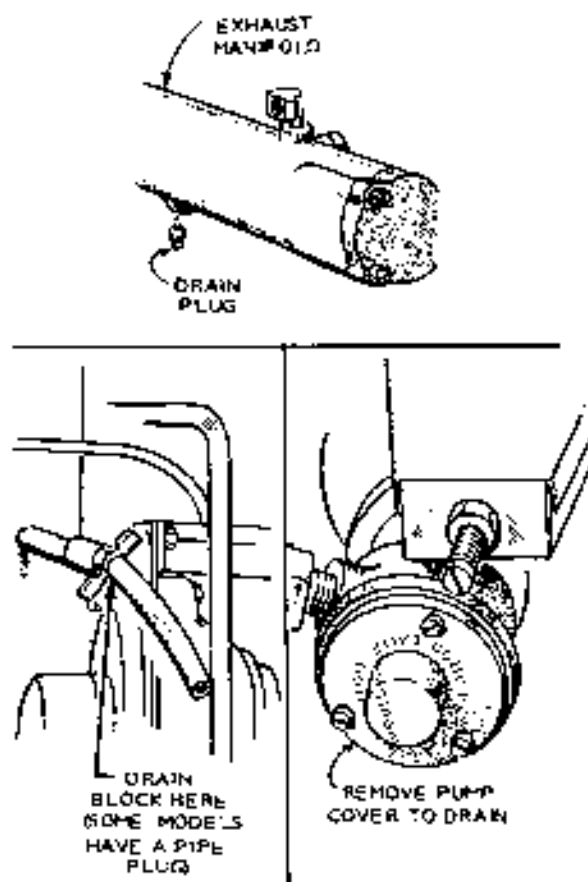

FIGURE 6-30. DRAIN LOCATION (J-SERIES)

Reverse Flushing

Immediately after draining the cleaning solution, flush the system; for best results, use reverse flushing. Flush the radiator first to allow the engine to cool as much as possible.

To flush the radiator:

1. Drain the system and disconnect radiator hoses at engine.
2. Secure flushing gun in radiator lower hose with a hose clamp, Figure 6-31.

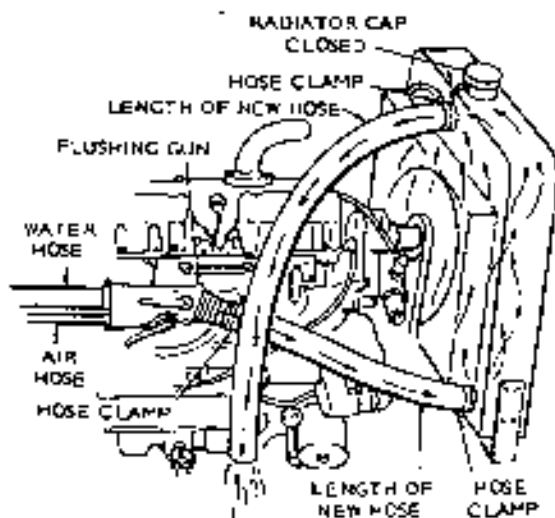

FIGURE 6-31. FLUSHING GUN INSTALLATION

3. Fill radiator with water.
4. Be sure radiator cap is on tight.
5. Apply air pressure gradually to avoid damage to radiator.
6. Shut off the air pressure and fill the radiator with water again and apply air pressure; repeat until water comes out clean.
7. Reconnect radiator hoses.
8. Clean and inspect the radiator cap.

To flush the engine:

1. Drain radiator or heat exchanger, cylinder block and exhaust manifold. Remove thermostats.
2. Remove the inlet and outlet hoses between the engine and radiator.
3. Close all drain plugs and attach the flushing gun nozzle to the water outlet, as near the exhaust manifold as practical. Restrict the normal inlet line opening until the system fills with water, then apply air pressure gradually. Repeat the process until the water from the cylinder block flows clean.
4. Remove flushing gun.

5. Reinstall thermostats, hoses and drain plugs and refill the system with the proper coolant.
6. When flushing is completed, check the system thoroughly for any leaks uncovered by the cleaning operations.

To flush heat exchanger:

1. Flush the engine water jacket as previously discussed.
2. First remove water outlet hose between engine water jacket to the heat exchanger.
3. Flush both fresh water side and raw water side of heat exchanger.
4. Remove rubber impeller pump cover to flush raw water side.
5. Flush the water-cooled exhaust manifold.
6. When flushing is completed, check the system thoroughly for leaks.

Testing Cooling System

The cooling system can be tested for two abnormal conditions: (1) insufficient water flow, and (2) air leaks.

1. To measure water flow, install a tank of known quantity at the water outlet. Run the engine until the thermostat opens and then measure the length of time necessary to fill the tank. From this, obtain the flow in gallons per minute (GPM). Minimum values are given in the engine data section. If water flow is below minimum, check pump operation or open supply valve, and inspect the passages and water lines for clogging.
2. Air leaks cause premature impeller failure. To test for air in the cooling system, run the engine, insert the cooling system outlet into a tank of water and watch for bubbles. If bubbles appear, inspect the cooling system thoroughly to find the source of air entry.

Repair Notes

The heat exchanger should not require any repair under normal service conditions. However, if it should become clogged, remove the ends and clean out the tubes.

Whenever making repairs on the cooling system, tighten all connections thoroughly. Use thread sealing compound on all threaded connections. This is especially important because of the damage air can cause.

All water lines should be 1/2 inch (13 mm) inside diameter or larger. Long runs of pipe or hose need larger inside diameter to reduce resistance. Remember, the final test is always correct water flow.

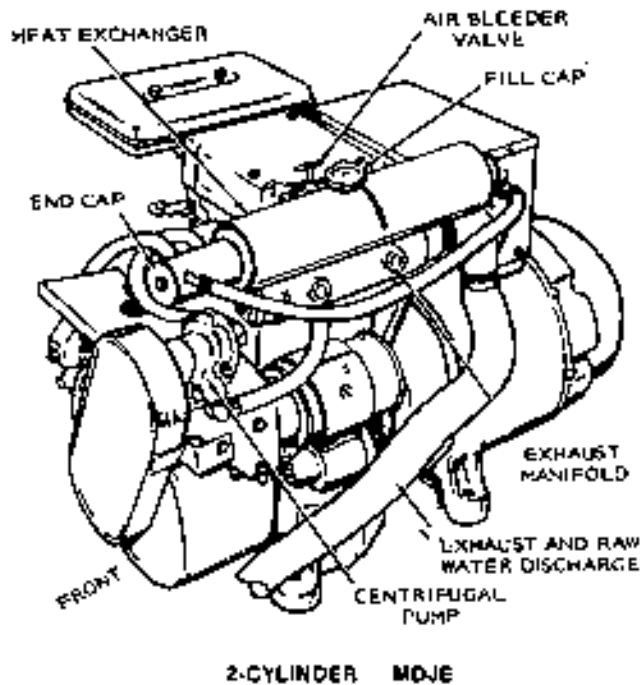

2-CYLINDER MDJE

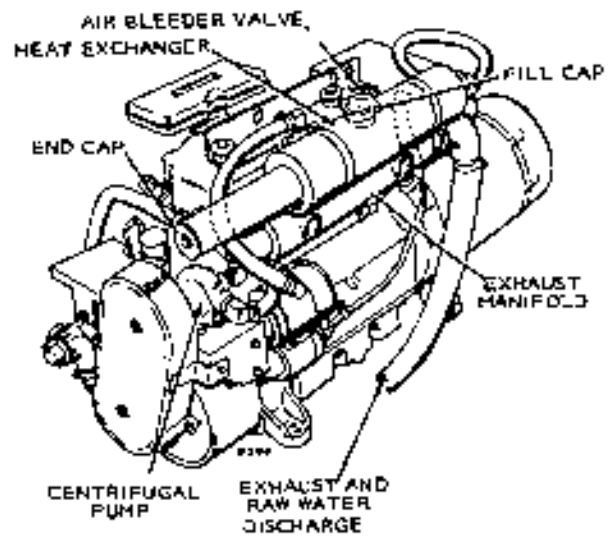

4-CYLINDER MDJF

FIGURE 6-32. TYPICAL HEAT EXCHANGER COOLING SYSTEMS

After making repairs on the cooling system, tighten all connections thoroughly. Use Permatex or thread sealing compound on all threaded connections to prevent leaks or the entry of air into the system.

Read instructions on Permatex sealer can before applying sealer to engine parts.

HEAT EXCHANGER KIT INSTALLATION — J-SERIES

Onan heat exchanger kits provide an efficient cooling system which protects your engine's water jacket against the effects of sea water and sediment.

The following instructions cover installation, preparation for operation, testing and heat exchanger maintenance. Read them thoroughly before beginning installation.

MJB and MDJB Kit No. 130-0914

1. Drain cooling system. Refer to Figure 6-32.
2. Remove belt guard (Figure 6-33), flywheel cover and flywheel. Remove two cap screws holding flywheel pulley and flywheel capscrew, then lift off pulley. Re-install flywheel capscrew part way and re-install pulley over it. Using pulley as a gear puller, tighten the two capscrews to pull flywheel loose.
3. Remove starter motor electrical connections. Remove starter motor rear mount and the two capscrews holding starter to mounting flange. Lift off starter motor.

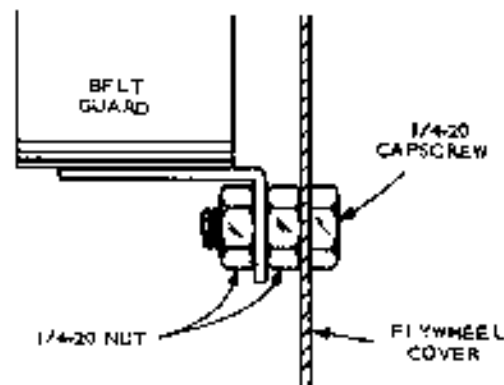

FIGURE 6-33. BELT GUARD MOUNTING (SEE STEP 11)

MJB ONLY: Disregard steps 3 and 4. Mount the new starter flange (step 5) using the flange spacer furnished with the kit and install the flange cover over the starter motor hole.

4. Remove starter flange from crankcase by removing three capscrews.
5. Mount new flange furnished in kit using old flange spacer and capscrews.

REV. 11-76

6. **5MJB MODELS ONLY**—Cut a notch in flywheel cover to accommodate starter flange. Cut notch to dimensions shown in Figure 6-34.
7. Mount flywheel and flywheel cover and install starter motor.

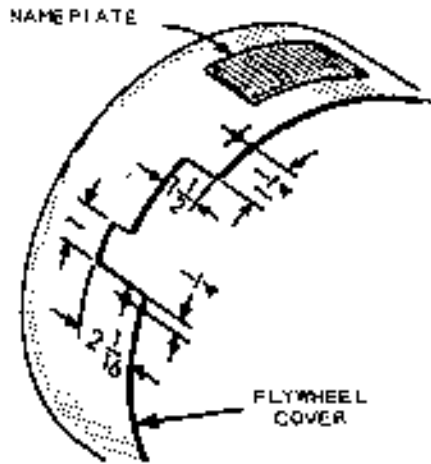

FIGURE 6-34. CUTTING NOTCH IN FLYWHEEL COVER (5MJB ONLY)

8. Remove governor adjusting nut and governor spring bracket. On diesels, reinstall the governor solenoid immediately with the capscrew toward the right.

9. Remove water line between water pump and engine block and remove brass elbow from block. Remove and discard gear cover capscrew holding water line support.
10. Mount water pump bracket on engine with capscrews furnished (Figure 6-35). Use two 5/16-18 x 3/4-inch capscrews to secure to starter motor flange; one 5/16-18 x 1-inch to gear cover; and two 1/4-20 x 5/8-inch to upper left hand corner of backplate.

For convenience, the nameplate can be moved to a more accessible position before mounting the bracket.

11. **EARLY MODELS ONLY**—Some early models were built without a hole and weld nut in the front surface of the flywheel cover to mount the belt guard.
 - a. If there is no hole, clamp belt guard to the heat exchanger bracket and mark location of lower mounting hole.
 - b. Remove flywheel and drill a 1/4-inch hole.
 - c. For easy removal, mount the capscrew as shown in Figure 6-33. The 1/4-20 nut isn't furnished.
 - d. The belt guard can be mounted on this assembly with a second nut and lockwasher.
 - e. Reinstall flywheel guard on engine.

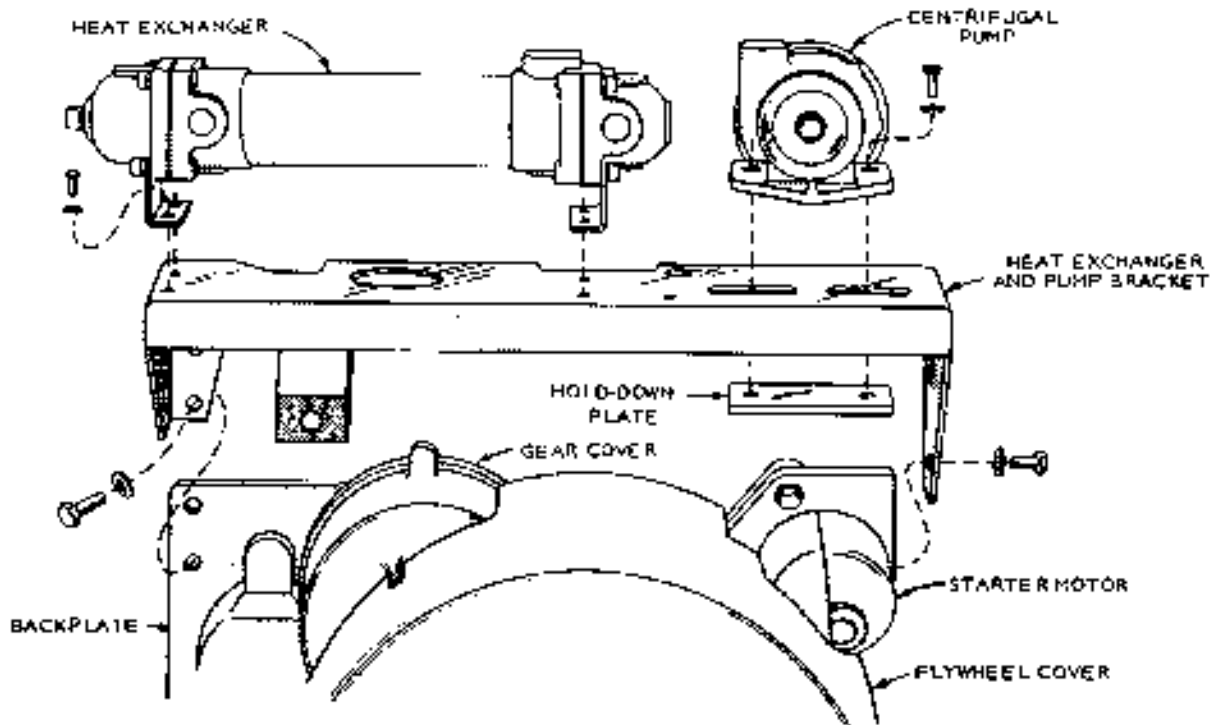

FIGURE 6-35. WATER PUMP MOUNTING BRACKET

12. Rotate manifold end for end; rearrange mounting flanges as needed for remounting on engine.
 - a. Disconnect exhaust manifold at engine mounting flange.
 - b. Remove pipe plug from bottom at manifold.
 - c. Remove exhaust elbow from manifold and swap it with 1-1/4 inch pipe plug at opposite end of manifold. Discard used 1-1/4 inch close nipple. Use new nipple furnished in kit to mount exhaust elbow at opposite end of manifold.
 - d. Install flush type 3/8 inch pipe plug in hole on bottom of manifold.
 - e. Install two 90-degree brass elbows (3/8 inch pipe to 1/2 inch hose) in threaded holes that were vacated on top of manifold. Direct outlet of rear elbow at exhaust pipe end about 45 degrees toward engine side. Direct outlet of front elbow toward the end to which it is near.
 - f. Reinstall manifold on engine using new gaskets furnished.
13. Mount centrifugal pump on bracket with the shaft pointing forward. Use hold-down plate furnished to secure pump (Figure 6-35).

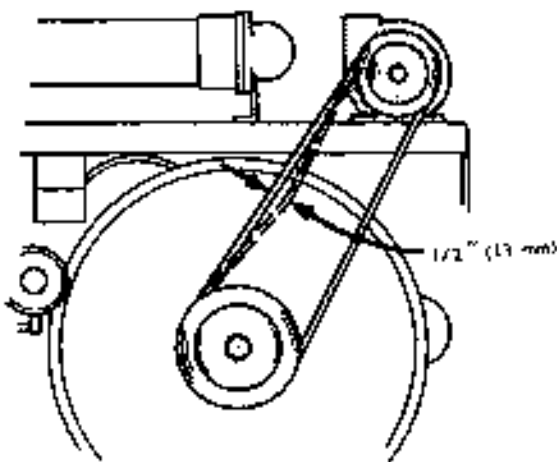

FIGURE 6-35. PUMP BELT TENSION

When rotating the pump body on its pedestal to adapt it to the engine, the pump body must be centered in a fore and aft direction on the impeller. Failure to do this will result in either the outer or inner face of the impeller rubbing on the pump body. When this happens, the pump generates enough heat to literally burn it up. You can't see this adjustment; it must be felt as you rotate the pump by hand. It must be free and not binding. This means the pump must be adjusted before the drive belt is on the pulley.

14. Mount pump pulley on fresh water pump; align it with crankshaft and drive pulley and secure.

15. Install belt over pump and drive pulleys. Adjust pump to allow about 1/2 inch belt deflection (Figure 6-36) and secure pump in position.
16. Remove and discard copper water line from thermostat housing to exhaust manifold, inverted male connector on thermostat cover, thermostat housing, and two studs from thermostat mounting surface.
17. Remove control box.
18. Drill and tap two holes in rear of cylinder head, Figure 6-37. Use a #21 drill and 10-32 tap. Mount new thermostat switch using 10-32 screws furnished in kit.

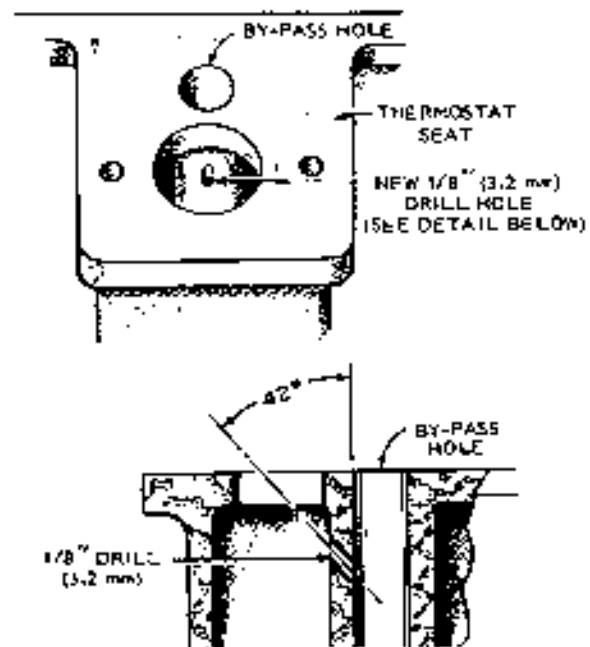

FIGURE 6-37. DRILLING FOR HIGH WATER TEMPERATURE SWITCH

CAUTION Do not use the switch removed from the thermostat cover. This switch operates at a lower temperature and would cause erratic operation when mounted on the cylinder head.

19. Remove thermostat and drill a 1/8-inch hole from thermostat compartment to by-pass hole, Figure 6-38. Be careful not to damage surface of thermostat seat.
20. Install control box.
21. Install gasket, thermostat housing and heat exchanger mounting bracket (in that order) from kit on the engine thermostat compartment. Install 1/8-inch nipple, 1/8-inch coupling and air vent on thermostat housing. Using two capscrews (5/16-18 x 2-1/2"), coat threads with sealing compound, secure heat exchanger bracket and thermostat assembly to engine.

MJC, MDJC, and MDJF Kit No. 130-0915

1. Drain cooling system.
2. Remove governor adjusting nut and governor spring bracket. On diesels, reinstall governor solenoid immediately with capscrew toward the right.
3. Remove water line between water pump and engine block. Mount water pump bracket on engine with the capscrews furnished, Figure 6-35. Use two 5/16-18 x 3/4-inch capscrews to secure it to the starter motor flange; one 5/16-18 x 1-inch to the gear cover; and two 1/4-20 x 5/8-inch to secure it to the upper left hand corner of the backplate.

For convenience, the nameplate can be moved to a more accessible position before mounting bracket.

5. **EARLY MODELS ONLY**—Some early models were built without a hole and weld nut in the front surface of the flywheel cover to mount the belt guard. If there is no hole, clamp belt guard to the heat exchanger bracket and mark location of lower mounting hole. Remove flywheel cover and drill a 1/4-inch hole. For easy removal at a later time, mount the capscrew as shown in Figure 6-34. The 1/4-20 nut isn't furnished. The belt guard can then be mounted on this assembly with a second nut and lockwasher. Reinstall the flywheel guard on the engine.
6. Rotate manifold end for end; rearrange mounting flanges as needed for remounting on engine.
 - a. Disconnect exhaust manifold at engine mounting flanges.
 - b. Remove pipe plug from bottom of manifold.
 - c. Remove exhaust elbow from manifold and swap it with 1-1/4 inch pipe plug at opposite end of manifold. Discard used 1-1/4 inch close nipple. Use new nipple furnished to mount exhaust elbow at opposite end of manifold.
 - d. Install flush type 3/8-inch pipe plug in hole on top of manifold and the square head plug on bottom of manifold.
 - e. Install two 90-degree brass elbows (3/8-inch pipe to 1/2-inch hose) in threaded holes that were vacated on top of manifold. Direct outlet of rear elbow at exhaust pipe end about 45 degrees toward engine side. Direct outlet of front elbow toward the end to which it is near.
 - f. Reinstall manifold on engine using new gaskets furnished.
7. Mount centrifugal pump to bracket with the shaft pointing forward. Use hold-down plate furnished to secure pump.

When rotating the pump body on its pedestal to adapt it to the engine, the pump body must be centered in a fore and aft direction on the impeller. Failure to do this will result in either the outer or inner face of the impeller rubbing on the pump

body. When this happens, the pump generates enough heat to literally burn it up. You can't see this adjustment; it must be felt as you rotate the pump by hand. It must be free and not binding. This means the pump must be adjusted before the drive belt is on it.

8. Mount pump pulley on centrifugal pump, align it with the crankshaft drive pulley and secure.
9. Install belt over pump to allow about 1/2-inch deflection to belt, Figure 6-36, and secure pump in position.
10. Remove and discard: copper water line from thermostat housing to exhaust manifold, inverted male connector on the thermostat cover, thermostat housing, thermostat and 4 studs from the thermostat mounting surface.
11. MDJC Spec A through C and MJC Spec A through D; remove control box.
12. MDJC Spec A through C and MJC Spec A through D; drill and tap 2 holes in rear of cylinder head, Figure 6-37. Use a #21 drill and 10-32 tap. Mount new thermostat switch using the 10-32 screws furnished.

CAUTION

Do not use the switch removed from the thermostat cover on MDJC Spec A through C and MJC Spec A through D. This switch operates at a lower temperature and would cause erratic engine operation when mounted on the cylinder head.

13. Remove thermostat and drill a 1/8-inch hole from thermostat compartment to the by-pass drilling, Figure 6-38. Be careful not to damage the surface of thermostat seat.
14. MDJC Spec A through C and MJC Spec A through D; install control box.
15. Install gaskets and water manifold from kit on thermostat compartment. Install 1/8-inch nipple, 1/8-inch coupling and air vent on water manifold. Using four capscrews (5/16-18 x 2-1/2-inch) and copper washers, coat threads with sealing compound, secure heat exchanger brackets and water manifold to engine. Install thermostat gasket and thermostat housing, using the two capscrews (5/16-18 x 1-1/4-inch) and copper washers furnished.
16. Using ring clamps furnished in kit, secure heat exchanger to its bracket.
17. Remove existing engine mounted water pump (raw water) and install a new pump furnished in kit.
18. Install plumbing fittings furnished as follows, using a thread sealing compound on each (see Figure B-4D for location and correct facing).
 - A close nipple, elbow and half nipple in the centrifugal pump (fresh water) inlet and outlet.
 - Hose elbow and reducer bushing at engine mounted water pump (raw water) outlet.
 - Hose adapter in the engine mounted water pump (raw water) inlet.

NOTE: MODEL MDJB CYLINDER HEAD SHOWN HERE
MODEL M; B CYLINDER HEAD IS SIMILAR.

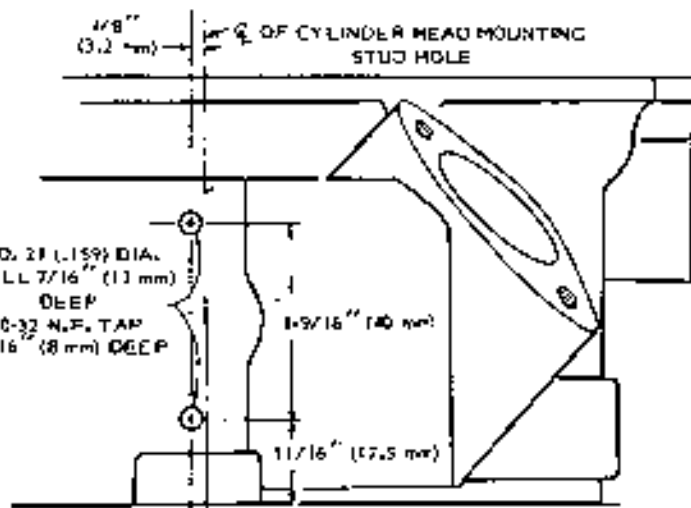

FIGURE 6-38. DRILLING BY-PASS

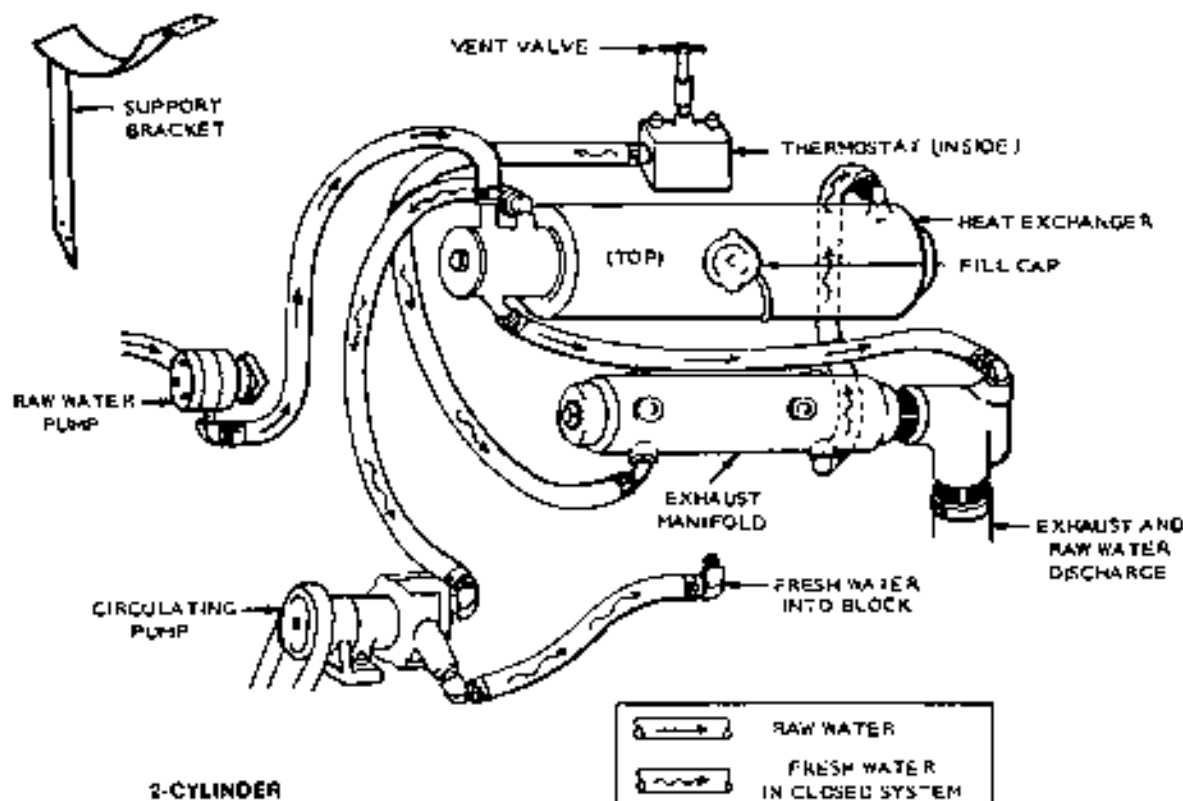

FIGURE 6-39. HEAT EXCHANGER HOSE SCHEMATIC

22. Using ring clamps furnished, secure heat exchanger to its bracket.
23. Install plumbing fittings furnished as follows, using a thread sealing compound on each:
 - Elbow hose fitting in centrifugal pump inlet
 - Nipple hose fitting in thermostat housing
 - 1/4 inch hose elbow fitting at engine mounted pump outlet
 - Elbow hose fitting at centrifugal pump outlet (side of pump); elbow hose fitting in cylinder block inlet; face all elbows as illustrated in Figure 6-39
 - Elbow hose fitting in exhaust elbow
23. Open air vent valve on thermostat housing.
24. Fill closed cooling system with fresh water or water and antifreeze mixture (5 quarts).
25. Operate unit for 10 minutes at full load; watch for leaks.
26. Shut down unit.

CAUTION After running unit 10 minutes, the closed cooling system is pressurized and hot. Open the 14-pound pressure cap slowly to vent pressure.

27. Slowly open pressure cap and check water level.
28. Fill system to top of heat exchanger. Check for and correct any leaks.

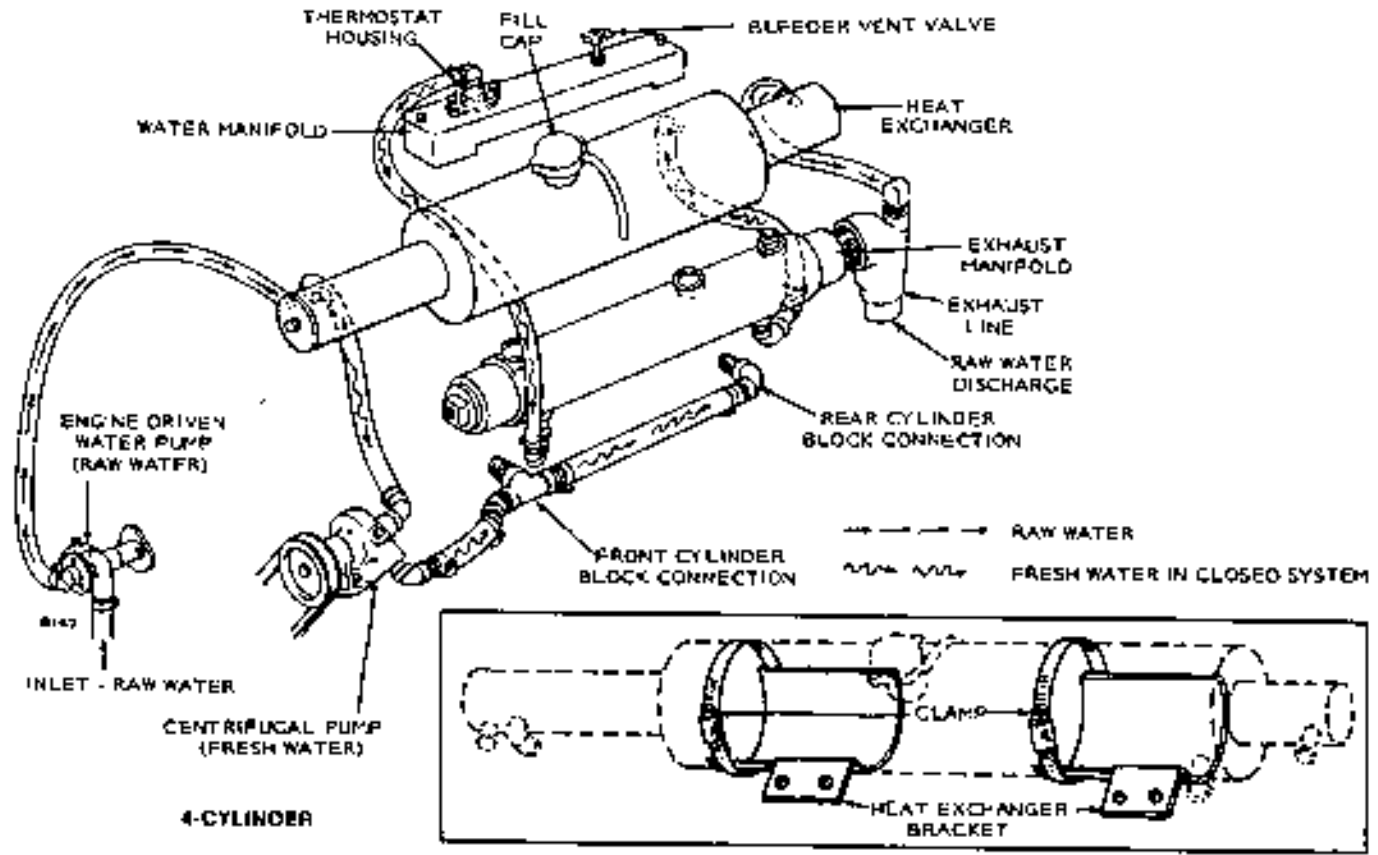

FIGURE 6-40. HEAT EXCHANGER HOSE SCHEMATIC (BEGIN SPEC D)

- Close nipple, elbow and half nipple in the rear cylinder block inlet.
 - (2) Close nipples, tee, 45-degree elbow, and (2) halfnipples in the front cylinder block inlet.
 - Hose elbow in the exhaust elbow.
 - Hose elbow in the thermostat housing.
 - Close nipple, (2) elbows, short nipple and a half nipple in the exhaust manifold (front).
 - Close nipple, street elbow, elbow and a half nipple in the exhaust manifold (rear).
 - Countersunk plug on top and square head plug on bottom of exhaust manifold.
19. Measure and cut hose to lengths required and install using clamps furnished. Use 3/4-inch hose for the fresh water connections and the 1/3-inch hose for raw water connections. See Figure 6-40.
 20. Open air vent valve on thermostat housing.
 21. Fill closed cooling system with fresh water or water and antifreeze mixture.
 22. Operate unit for 10 minutes at full load; watch for leaks.
 23. Shut down unit.
- CAUTION** After running unit 10 minutes, the closed cooling system is pressurized and hot. Open the 14-pound pressure cap slowly to vent pressure.
24. Slowly open pressure cap and check water level.
 25. Fill system to top of heat exchanger. Check for and correct any leaks

PREPARATION FOR OPERATION

If necessary, prime the engine mounted raw water pump. To do this, remove pump outlet hose at the heat exchanger inlet connection and fill hose and pump with water. Reconnect hose at heat exchanger when pump is primed. Remove the pressure cap on the heat exchanger and open the air bleeder vent valve on the water manifold. Fill the closed water system with fresh water and a rust inhibitor. If there is danger of freezing use an approved antifreeze. Close pressure cap when system is filled.

TESTING

Start the engine and following instructions in the operator's manual, adjust the governor spring tension for proper engine speed.

Before beginning regular operation, test the water flow through the raw water system. To do this, disassemble the raw water outlet hose at the discharge connection on the exhaust manifold. Using a separate tank to catch the raw water discharge, run the engine for one minute and measure the amount of water that flows from the discharge hose into the tank. The water flow must exceed 4 gallons per minute (gpm), Kit No. 130-0914 or 3.5 gallons per minute (gpm), Kit No. 130-0915. Otherwise a larger hose or a shorter hose must be installed on the raw water intake to the engine mounted pump.

The engine will not cool properly under all conditions unless water flow at the exhaust outlet exceeds the required flow rate.

When the necessary corrections have been made, the generating set is ready for regular operation.

SIPHON BREAK

The siphon break (anti-siphon) is a vacuum operated vent valve that opens the exhaust water discharge line to the atmosphere when the engine shuts down. The open vent valve prevents floatation water (sea water) from being siphoned into the exhaust manifold and cylinders on engines installed below the load waterline.

The siphon break kit is required for all marine (Aqualift muffler, raw water or heat exchanger) installations in which the exhaust water injection elbow is below load water level. Mount the siphon break no less than 12 inches above load water level. If space does not permit, the siphon break can be remotely mounted (within 5 feet from the exhaust water injection elbow). In all installations, the siphon break must be mounted vertically (threaded end of valve pointing down). Use pipe straps to secure the assembly to the frame or bulkhead. Use flexible rubber hose for connections.

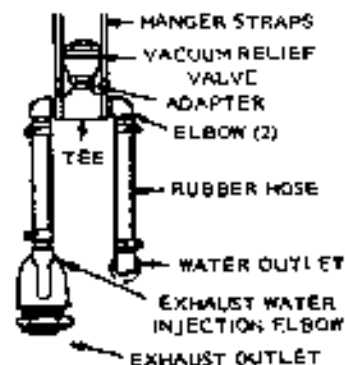

FIGURE 6-41. SIPHON BREAK ASSEMBLED

Kit Assembly

Assemble the siphon break as follows:

1. Install two elbows using adapters in opposite ends of Tee, Figure 6-41.
2. Install adapter in remaining hole of Tee.
3. Mount vacuum relief valve on Tee adapter.

Installation

1. Locate and hang siphon break vertically within 5 feet (1.5 m) of exhaust water injection elbow and 12 inches (305 mm) or more above the load waterline, Figure 6-42.
2. Disconnect exhaust water (raw) discharge hose at exhaust water injection elbow on heat exchanger or other models where this hose has been assembled.

If the hose is adequate, connect it to the siphon break inlet elbow. Otherwise, use new hose, step 3.

3. Connect exhaust water discharge hose between engine water outlet (raw water, aqualift, or heat exchanger) and siphon break inlet elbow, Figure 6-43. Turn elbow or replace with straight fitting to prevent crimps in hose.
4. Connect hose between siphon break outlet elbow and exhaust water injection elbow. Tighten all hose clamps to prevent leaks.

CAUTION Be sure the slotted opening in the vacuum relief valve is open to atmospheric pressure. The siphon break will not function if the relief valve slot is closed in any way.

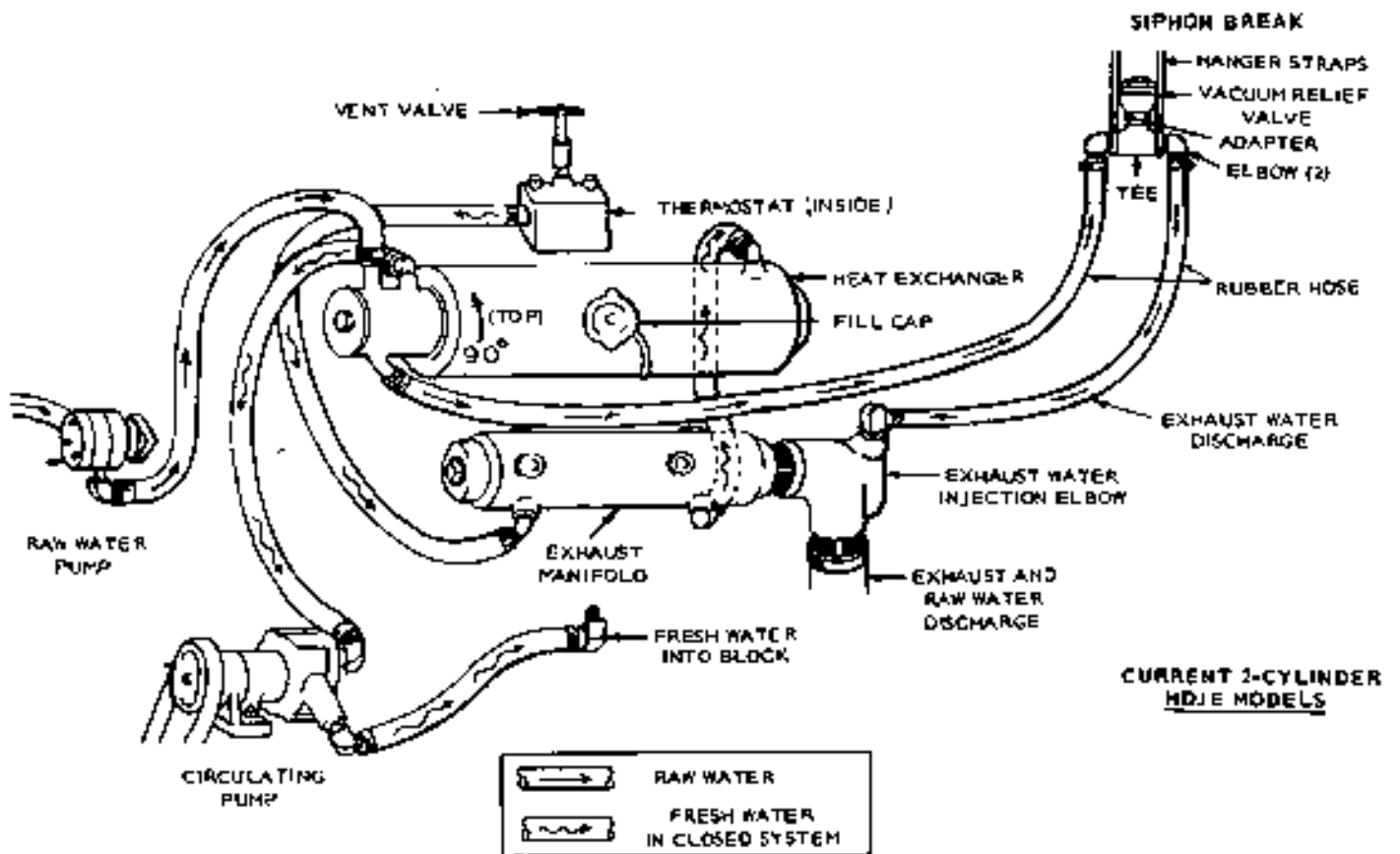

WARNING Do not remove pressure cap on heat exchanger until all pressure has been carefully vented. Otherwise, serious personal injury from scalding water or steam could result.

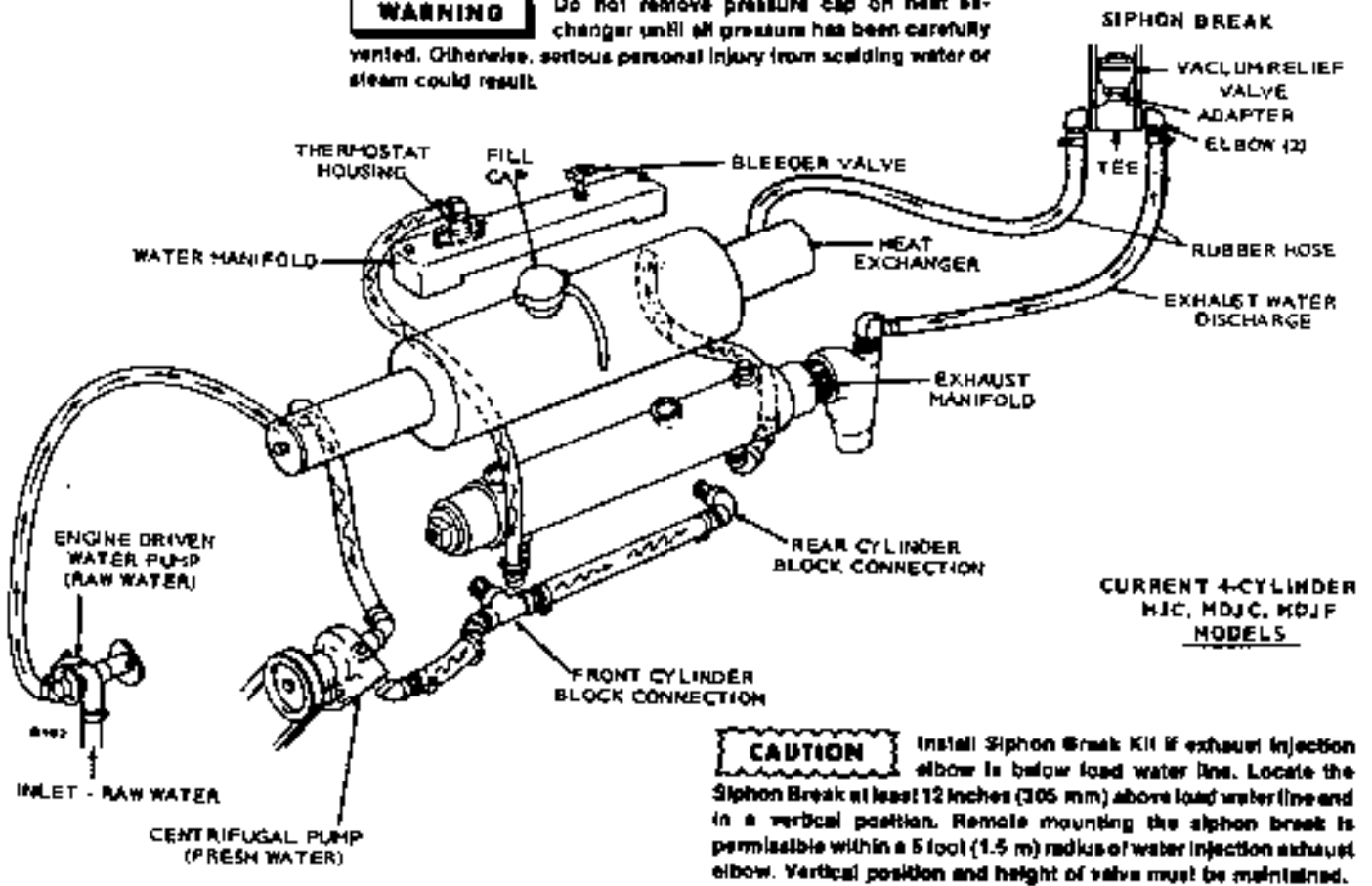

FIGURE 8-42. HEAT EXCHANGER HOSE SCHEMATIC WITH SIPHON BREAK

CAUTION Install Siphon Break Kit if exhaust injection elbow is below load water line. Locate the Siphon Break at least 12 inches (305 mm) above load water line and in a vertical position. Remote mounting the siphon break is permissible within a 5 foot (1.5 m) radius of water injection exhaust elbow. Vertical position and height of valve must be maintained.

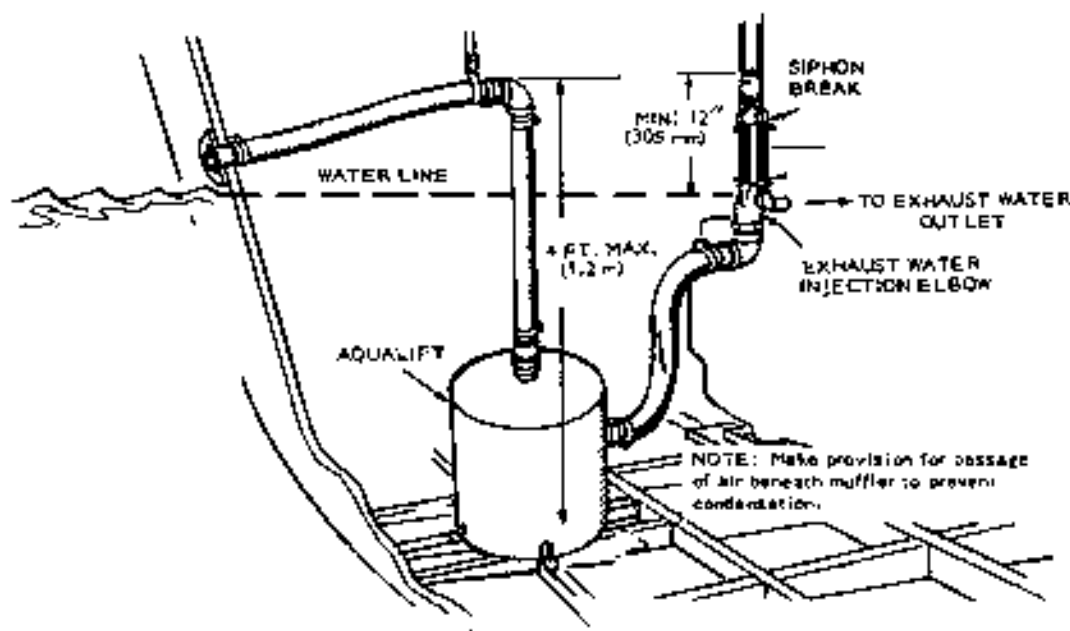

FIGURE 6-43. AQUALIFT INSTALLATION WITH SIPHON BREAK.

COOLING PROBLEMS FROM INTERNAL CORROSION

Air, which contains oxygen (21 percent by volume), gets into the cooling system causing serious problems because aeration of the water accelerates corrosion even at normal engine temperatures. Some air space is needed even in leak-tight systems because all closed systems require an expansion area. Additional air also enters through small leaks at hose connections, the water pump, or the vacuum valve in the pressure cap each time the engine shuts down and cools off. It is the oxygen in the coolant which causes the corrosion (rusting or pitting of ferrous metals) of internal engine surfaces. Turbulence in the circulated coolant mixes the air into the coolant. The minute mineral particles from corrosion circulate to all components of the cooling system, such as radiator cores. They then form deposits (scale) that eventually block small passages and impair radiation and heat transfer to the atmosphere.

Since this scale is a poor conductor of heat, the usual results are overheating, a clogged radiator, and pressure cap or thermostat malfunction. Heavier scale formations around the combustion chambers,

pistons, valve seats, and valve stems raise the engine operating temperature above normal and cause engine damage. Excessive operating temperatures may cause burned valves and seats, warped valve stems, or even cracked cylinder blocks or heads.

Larger particles or substances such as dirt and slum from vegetable growths and greases, or oil from leaky head gaskets also find ways to enter the closed cooling systems. All of these things add together to prevent circulation and cause engine temperatures to rise. Higher than normal engine temperatures reduce engine efficiency, cause apparent power losses, and increase gasoline and oil consumption.

Cooling efficiency losses are balanced by increased clearances, such as bearing wear and decreased frictional heat in a worn engine. Therefore, the cooling system must be thoroughly cleaned whenever an engine is rebuilt or new parts are installed. Otherwise, the increased frictional temperatures and expansion in the newer parts could damage the engine to a greater extent.

SECTION 7.

FUEL SYSTEM — GASOLINE

INDEX

MECHANICAL FUEL PUMPS	7-1
Description and Operation	7-1
Troubleshooting the Fuel Pump	7-1
Removal	7-2
Installation	7-2
Repair	7-2
BF ENGINE PULSATING DIAPHRAGM FUEL PUMP	7-3
Servicing Pulsating Diaphragm Fuel Pump	7-3
BENDIX ELECTRIC FUEL PUMPS	7-4
Disassembly	7-5
Assembly	7-5
ONAN ELECTRIC FUEL PUMP	7-5
Pump Data	7-5
COK AND NH HOME STANDBY FUEL FILTERS	7-6
CARBURETORS	7-6
Description and Operation	7-6
Carburetor Removal and Installation	7-8
Repair	7-8
BF Engine Carburetor	
Carburetor Cleaning and Inspection	7-10
Carburetor Disassembly and Repair	7-10
Removal	7-10
Replacing Needle Valve and Seat	7-10
Carburetor Float Adjustment	7-11
Carburetor Operation	7-11
Carburetor Adjustments	7-11
Initial Adjustments	7-11
Final Adjustments	7-11
Air Cleaner	7-12
BF, NH Power Drawer Carburetors	7-12
Carburetor Disassembly and Repair	7-12
Removal	7-12
Replacing Needle Valve and Seat	7-12
Carburetor Float Adjustments	7-13
Carburetor Cleaning and Inspection	7-13
Fuel Pump Filter Element	7-13
Air Cleaner Element	7-14

Fuel Solenoid	7-14
Carburetor Bowls.....	7-14
Governor Bail Joint.....	7-14
Electric Choke	7-15
CARBURETOR ADJUSTMENTS.....	7-15
VACUUM SPEED BOOSTER.....	7-16
AUTOMATIC CHOKES	7-16
General	7-16
Bi-Metal Coil	7-17
Choke Setting	7-17
Thermal Magnetic	7-18
Electric Solenoid—BF, NH Power Drawer	7-19
AIR CLEANER TYPES	7-20
Oil Bath Air Cleaner	7-20
Moistened Foam Air Cleaner	7-20
Dry Paper Air Cleaner	7-21
TABLE 7-1. CHOKES SETTINGS.....	7-17
TABLE 7-2. CHOKES OPENING DIMENSIONS	7-18
TABLE 7-3. CHOKES VOLTAGE RATINGS	7-18

MECHANICAL FUEL PUMPS

Description and Operation

Single action diaphragm fuel pumps (Figures 7-1, 7-2, 7-4) are standard equipment on all Onan gasoline and diesel engines except the BF which uses a pulsating diaphragm type of pump. A fuel sediment bowl filters engine fuel before it reaches the fuel pump.

The fuel pump is mechanically actuated by a rocker arm which rides on a lobe of the engine camshaft. A flexible diaphragm is operated up and down by a combination of rocker arm action and spring tension (Figure 7-1).

On the fuel intake stroke, the camshaft lobe causes the rocker arm to lift the diaphragm against the pressure of the diaphragm spring. This action pulls fuel from the gas line through the fuel sediment bowl. The same action draws the fuel through the intake valve into the pump inlet chamber and closes the outlet valve. As the camshaft lobe continues to rotate, the rocker arm relieves the pressure on the diaphragm spring allowing the spring to move the diaphragm toward the inlet and outlet valves exerting pressure on the fuel inlet chamber. This pressure causes the pump inlet valve to close and opens the outlet valve. The fuel is consequently forced through the pump outlet and into the carburetor.

Fuel is accepted by the carburetor only when the fuel inlet valve is opened by the float. When the specified fuel level in the float chamber is reached, fuel is shut off at the inlet valve.

With no demand for fuel from the carburetor, the diaphragm spring tension is not great enough to force the diaphragm against the float pressure in the inlet chamber of the pump. Thus, the rocker arm action continues, but the diaphragm remains stationary until the pressure against the carburetor float is relieved by a demand for fuel at the carburetor.

Troubleshooting the Fuel Pump

If fuel does not reach the carburetor, perform the following checks:

1. Check fuel tank to see if shutoff valve is open.
2. Make certain fuel tank cap vent is open
3. Remove fuel line from pump outlet and crank engine several times. On manual starting models, operate priming lever instead of cranking engine. Fuel should spurt from pump. If not, remove pump for repair or replacement.

If the pump delivers fuel, but the engine does not run properly, perform these tests with a pressure gauge before removing the pump.

1. Disconnect pump outlet line and install pressure gauge.
2. Test valves and diaphragm by operating priming lever a few times. The pressure should not drop off rapidly after priming has stopped.

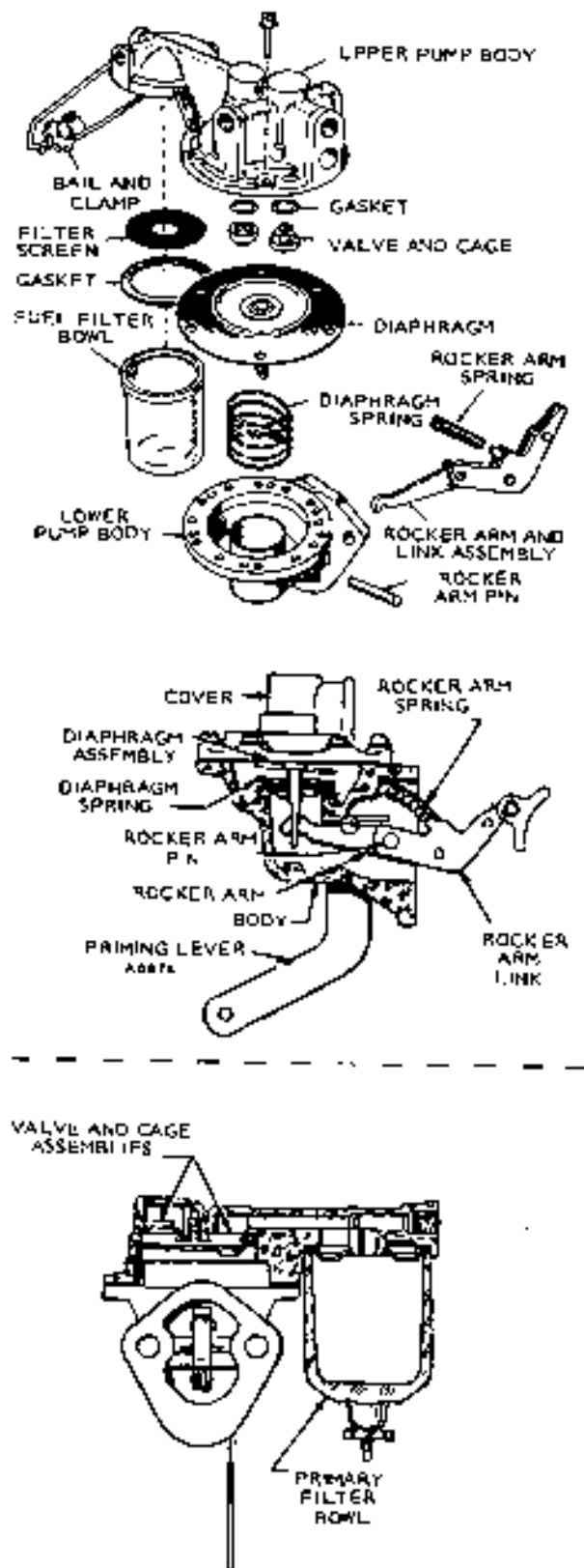

FIGURE 7-1. OCK SERIES MECHANICAL ACTUATED FUEL PUMP
CUTAWAY OF THE J SERIES MECHANICAL ACTUATED FUEL PUMP

3. Run engine at governor speed on fuel remaining in carburetor and measure fuel pump pressure developed. Pressure should measure between 2 and 3 psi with gauge held 16 inches above pump.

A low pressure reading indicates extreme wear in one part or significant wear in all parts of the pump. If pressure is above maximum, the diaphragm is too tight or the diaphragm spring too strong. A tight diaphragm is caused by fuel seeping under the diaphragm retainer nut and between the diaphragm layers, causing a bulge in the diaphragm. Low pressure or no pressure with little or no pressure leak, indicates a weak or broken diaphragm spring, worn linkage or leaky check valves. Any of the above conditions are cause for repair or replacement of the fuel pump.

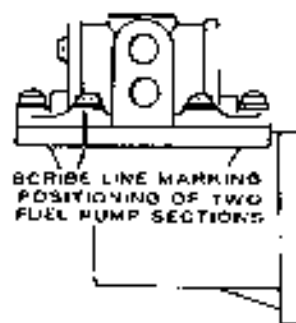

FIGURE 7-2. SCRIBE LINE

Removal

Follow this procedure when removing the fuel pump:

1. Remove fuel inlet and outlet lines from pump.
2. Remove two capscrews holding pump to engine. Discard gasket.
3. Notch pump body and cover with a file for reassembly in same relative position and remove screws holding body and cover together.
4. Tap body with a screwdriver to separate the two parts.
5. Install repair kit parts and reassemble fuel pump.

- c. Remove both valves and their gaskets from valve housing. Note position of valves in their housing so new valves can be correctly installed.
- d. Using a blunt punch, drive rocker arm pin out of pump (Figure 7-3).

Installation

Follow this procedure when installing the fuel pump:

1. Remove all gasket material from mounting pad pump flange. Apply oil-resistant sealer to both sides of new gasket and to threads of attaching bolts.
2. Position new gasket on pump flange and hold pump in position against mounting pad. Make sure rocker arm is riding on cam lobe. Turn crankshaft over until rocker arm is at low point of its stroke.
3. Press pump against pad, install attaching bolts, and alternately torque them to specifications.
4. Connect fuel inlet and outlet.
5. Operate engine and check for leaks.

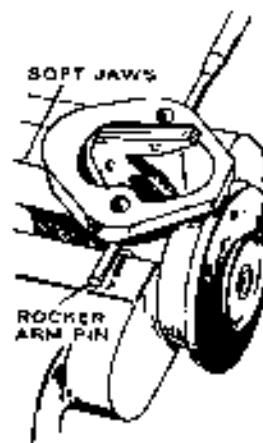

FIGURE 7-3. REMOVING ROCKER ARM PIN

Repair

1. Disassembly

- a. After fuel pump is removed from engine, scribe a line on flanges of pump body and valve housing to mark their original position (see Figure 7-2).
- b. Remove valve housing from fuel pump body (J series fuel pump valves are not supplied in the kit).

- e. Press diaphragm into fuel pump body and pull rocker arm outward to unhook diaphragm actuating rod from rocker arm link assembly.
- f. Remove diaphragm and diaphragm return spring, rocker arm and link assembly, and rocker arm return spring from pump body.
- g. Remove diaphragm actuating rod oil seal from pump body (Figure 7-1).
- h. Clean and inspect all fuel pump components and replace all unserviceable parts

Rev 10-75

2. Assembly

- a. Install inlet and outlet valves and their gaskets in their respective positions (Figure 7-1). Seat valves firmly.
- b. Lubricate diaphragm actuating rod.
- c. Position fuel pump diaphragm and spring assembly into pump body as shown in Figure 7-4.

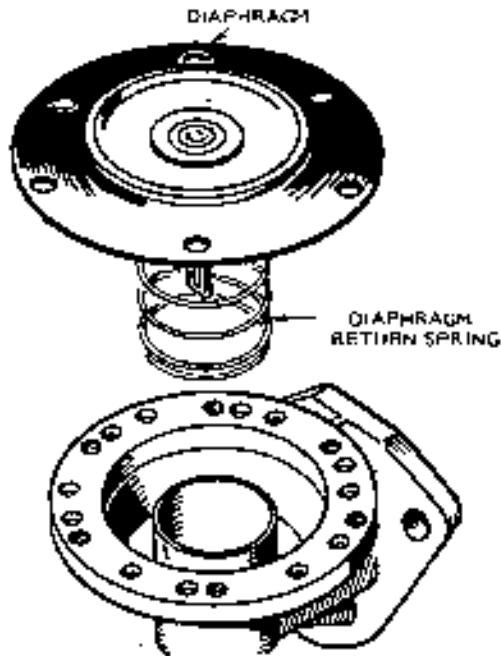

FIGURE 7-4. POSITIONING FUEL PUMP DIAPHRAGM

- d. Hold diaphragm assembly in pump body and position pump body so mounting flange faces up. Apply slightly more pressure to lower edge of diaphragm and insert rocker arm link assembly.
- e. Hook rocker arm link to diaphragm actuating rod.
- f. Install rocker arm return spring and hold it in place by cocking rocker arm slightly.
- g. Install rocker arm pin in pump body.
- h. Position valve body and pump body so two previously scribed marks align. Install all screws and lockwashers until they just engage pump body, being careful not to tear diaphragm fabric.
- i. Alternately and evenly tighten all screws.

BF ENGINE PULSATING DIAPHRAGM FUEL PUMP

Pulsating diaphragm fuel pumps use a combination of crankcase and spring pressure to work a diaphragm thus pumping fuel. This pump may be mounted to the side of the carburetor or, in some tractor applications, on the upper right hand corner of the blower housing. Refer to Figure 7-5 while reading the following functional description or servicing the pump.

On the downstroke of the engine piston, when the crankcase pressure is greatest, the pump diaphragm is forced back against the diaphragm spring compressing it and drawing fuel into the pump intake chamber. The fuel then passes through the intake reed valve into the output chamber side of the pump. On the compression stroke, when crankcase pressure is the lowest, the diaphragm spring forces the diaphragm out pushing fuel through the pump output reed valve into the output chamber and the fuel line.

Servicing the Pulsating Diaphragm Fuel Pump

1. Remove vacuum and fuel lines. Inspect lines for wear, cracking, etc.

On models where the fuel pump is mounted directly to the carburetor, no output fuel line exists. The pump cover containing the input and output chambers of the pump is an integral part of the carburetor body.

2. Scribe two lines (one each on opposite ends of pump) across pump parts. This will ensure correct alignment of pump parts with each other and carburetor when pump is reassembled.
3. Remove fuel pump attaching screws.
4. Holding pump carefully pull sections of pump apart. The diaphragm, plunger, return spring and plate, pump body and gaskets will now be loose.
5. Check parts for wear and damage. Replace with new parts where necessary.
6. The pump air bleed hole in pump base must be unclogged to allow unrestricted movement of pump diaphragm.

CAUTION A clogged diaphragm air bleed hole can cause diaphragm wear and seal damage while inhibiting pump operation.

7. Replace gaskets and reassemble pump as shown in Figure 7-5.
8. Install pump and replace lines. Make sure fuel line clamps are replaced on fuel line.

CAUTION Use care when reassembling the pump. All parts must be perfectly aligned or the pump will leak creating a fire hazard.

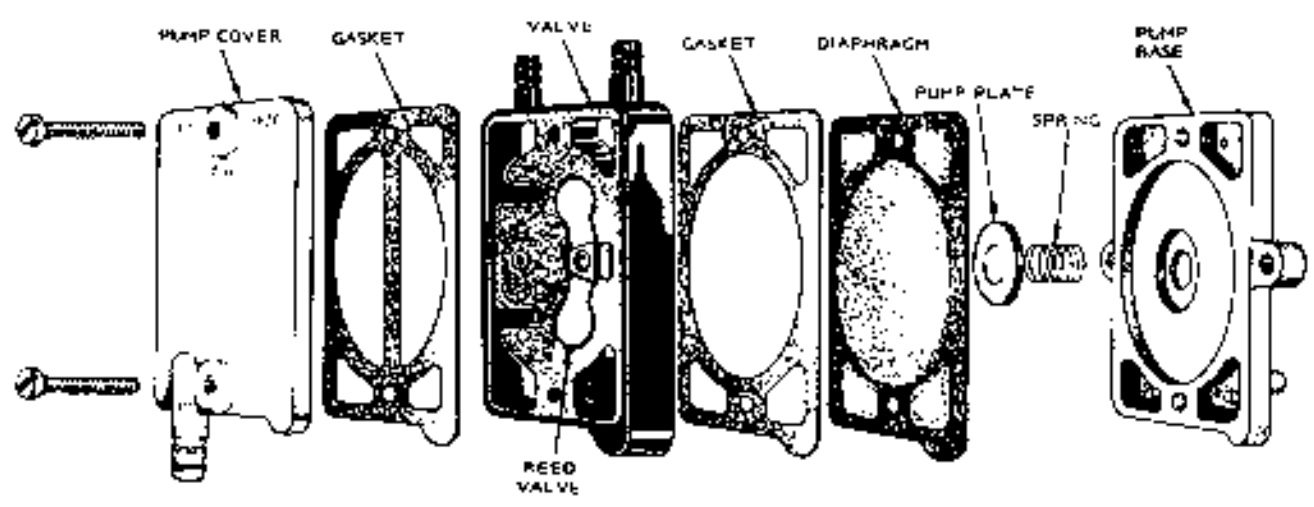
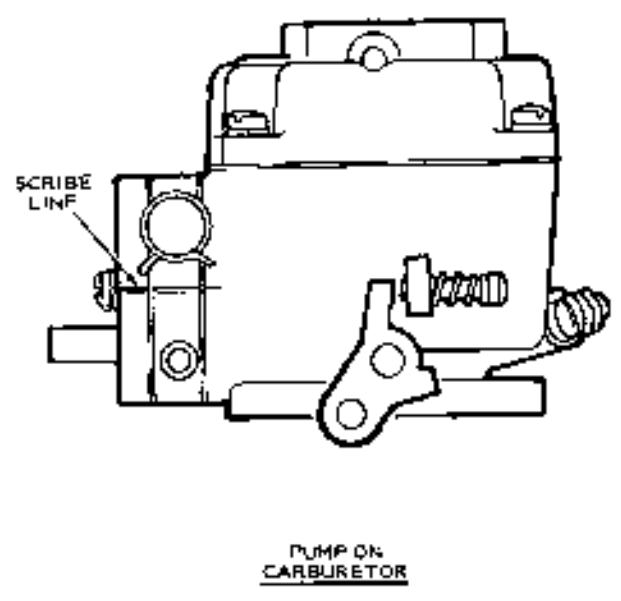
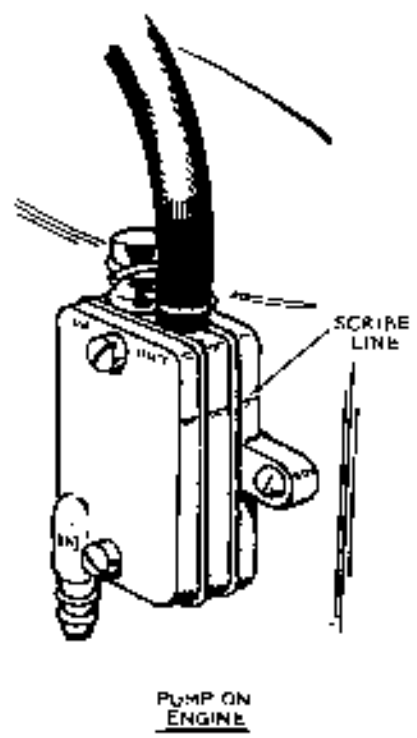

FIGURE 7-5. BF ENGINE PULSATING DIAPHRAGM FUEL PUMP

BENDIX ELECTRIC FUEL PUMPS

The following instructions cover the service procedure for the Bendix Electric Fuel Pump with code marking R-8 and after.

Service of these pumps is limited to cleaning the bottom cover, filter, plunger tube and plunger assembly

Disassembly

1. With 5/8-inch wrench, release bottom cover (1) from bayonet fittings. Twist cover by hand to remove from pump body.
2. Remove filter (4), magnet (3) and cover gasket (2), Figure 7-6. Wash filter in cleaning solvent and blow out dirt and cleaning solvent with air pressure. Check cover gasket and replace if deteriorated. Clean cover

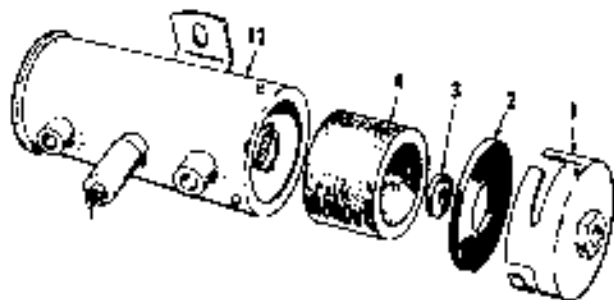

FIGURE 7-6. REMOVAL OF BOTTOM COVER, GASKET, MAGNET AND FILTER

3. Remove retainer spring (5) from plunger tube (11), using thin nose pliers to spread and remove ends of retainer from tube. Then remove washer (6), "O" Ring seal (7), cup valve (8), plunger spring (9) and plunger (10) from tube (11), Figure 7-7.

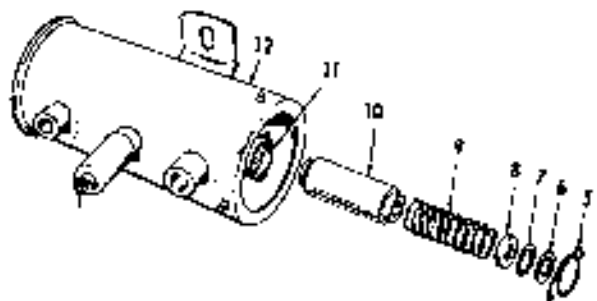

FIGURE 7-7. REMOVAL OF RETAINER, "O" RING, CUP VALVE, SPRING AND PLUNGER

4. Wash parts in cleaning solvent and blow out with air pressure. If plunger does not wash clean or if there are any rough spots, gently clean surface with crocus cloth. Flush the pump assembly in cleaning solvent. Blow out the tube with air pressure. To do a complete job, swab the inside of the tube with a cloth wrapped around a stick.

Assembly

1. Insert plunger assembly (10) in tube with buffer spring end first. Check fit by slowly raising and lowering plunger in tube. It should move fully without any tendency to stick. If a click cannot be heard, the interrupter assembly is not functioning properly in which case pump should be replaced.
2. To complete assembly, install plunger spring (9), cup valve (8), "O" Ring seal (7) and washer (6) as shown in Figure 7-7. Compress spring (9) and assemble retainer (5) with ends of retainer in side holes of tube (11).
3. Place cover gasket (2) and magnet (3) in bottom cover (1) and assemble filter (4) and cover assembly. Twist cover by hand to hold in position on pump housing. With 5/8-inch wrench, securely tighten bottom cover, Figure 7-6.

CAUTION Do not tamper with seal at center of mounting bracket at side of pump as it retains the dry gas, which surrounds the Electrical System, in the upper portion of the pump.

All pumps except HIGH CAPACITY pumps can be converted to either lower or higher pressure by simply changing the plunger return spring (9). However, if higher pressure is desired from a low pressure pump, plunger (10), as well as return spring (9), must be changed.

ONAN ELECTRIC FUEL PUMP

Every 100 operating hours or sooner, clean the filters. To gain access to the filters in the fuel pump (Figure 7-8), remove the four top Phillip screws and lift off the top filter assembly. Clean the two screen filters, reinstall and remount the top filter assembly. Be sure the gasket is in place.

Pump Data

1. Shut-off pressure 2 to 3½ psi (14 to 24 kPa).
2. Voltage range 9V to 15V.
3. Operating voltage 12 VDC minimum.

Instructions for removal and assembly of the points are supplied with the point repair kit.

WARNING Because of fire hazard, never expose fuel system to sparks, flame, etc.

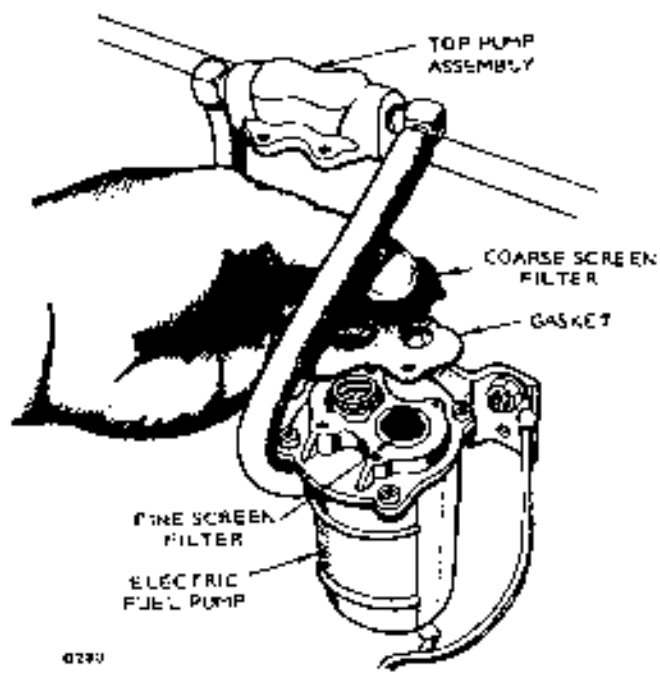

FIGURE 7-8. ONAN ELECTRIC FUEL PUMP

CCK AND NH HOME STANDBY FUEL FILTERS

Every 100 operating hours or sooner, clean the fuel filter elements. Remove the gas tank cap and fuel pickup assembly. Inspect the ball check and filter (Figure 7-9) and clean with compressed air.

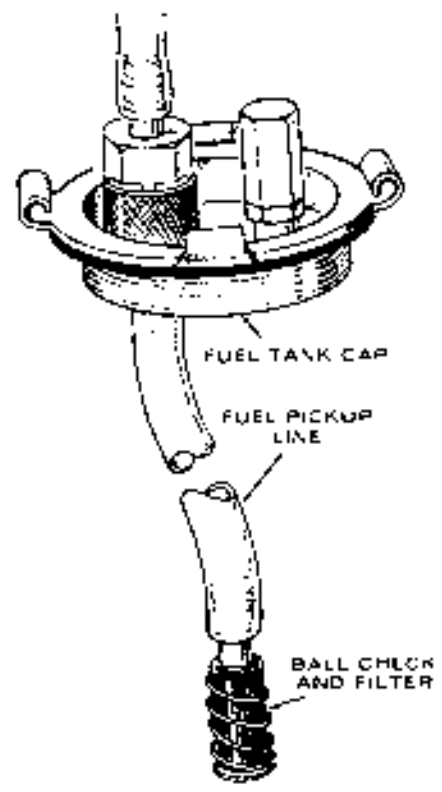

FIGURE 7-9. FUEL CAP AND PICKUP ASSEMBLY

CARBURETOR

Description and Operation

Onan engines currently in production use either a downdraft or a sidedraft single throat float-type carburetor. Figure 7-10 shows a downdraft-type carburetor commonly used on CCK engines. Figure 7-11 shows a sidedraft carburetor similar to those used on the AK, AJ, NB, NH and J series gasoline engines.

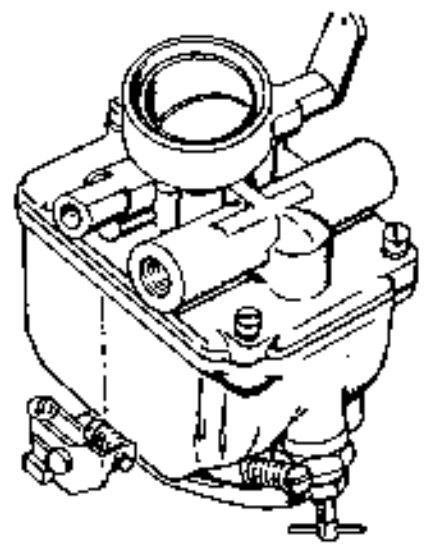

FIGURE 7-10. DOWN DRAFT TYPE CARBURETOR

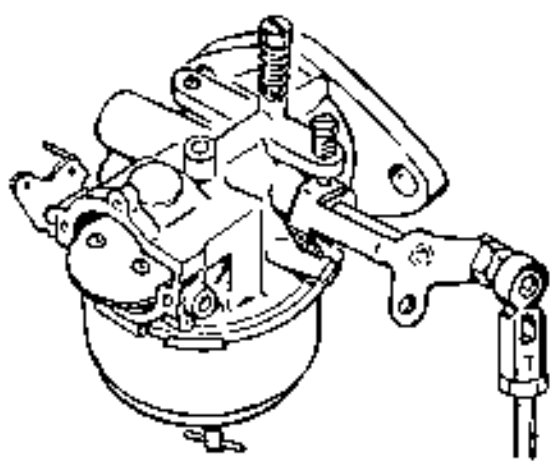

FIGURE 7-11. SIDE DRAFT TYPE CARBURETOR

These carburetors provide engine operation by controlling the proportions of fuel and air that are delivered to the engine cylinders for combustion. Air

is drawn into the carburetor air horn (Figure 7-12) by manifold vacuum. As air passes through the carburetor on its way to the cylinders, low pressure is created at the venturi of the carburetor. The fuel bowl is vented to the atmosphere and to carburetor air inlet pressure through a vent hole in the carburetor body assembly. The higher air pressure exerted on the fuel in the bowl forces the fuel to travel up through the fuel discharge channels and out into the air stream passing through the carburetor. The air and fuel vapor is mixed at this point and distributed into the engine cylinders for combustion.

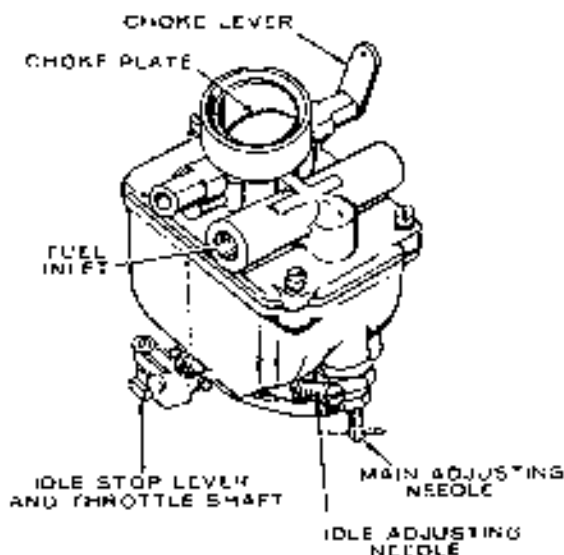

FIGURE 7-12 FUNCTIONAL CARBURETOR DIAGRAM

The fuel level in the carburetor bowl is extremely important to efficient carburetor operation. If the fuel level in the bowl is below the specified setting, a lean fuel to air mixture will result. A rich fuel to air mixture results from a higher than specified fuel level. The fuel inlet system of the carburetor maintains the fuel level in the carburetor bowl. Fuel enters the fuel bowl through the fuel needle valve (Figure 7-13). The fuel flow to the bowl is regulated by the distance the fuel needle valve is moved off its seat. Correct fuel pump pressure is a must if the carburetor fuel level is to be maintained within specified limits.

The fuel level in the carburetor bowl is maintained by the float and lever assembly which controls the fuel needle valve. The needle valve, which rides on the tab of the float and lever assembly, reacts to any change in height of the float and fuel level.

Most carburetors on Onan units come equipped with a high speed load adjusting valve and an idle adjust valve which controls the fuel to air mixture when the unit is idling.

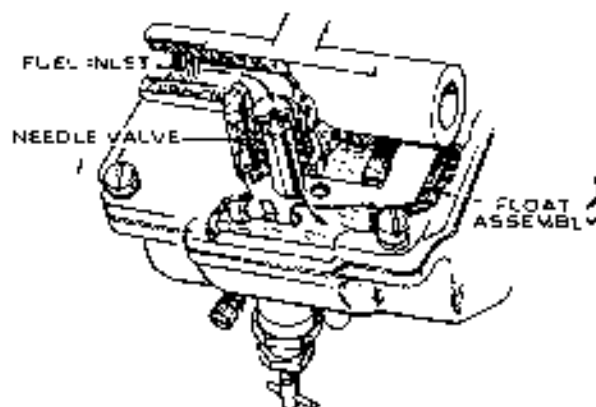

FIGURE 7-13. FUEL INLET SYSTEM

The main fuel supply system of the carburetor supplies the fuel required for engine operation under normal load conditions (Figure 7-14). This system begins to function when the air flow through the carburetor venturi creates a sufficient vacuum to start fuel flowing to the intake manifold. The vacuum at the discharge nozzle increases as the air flow increases.

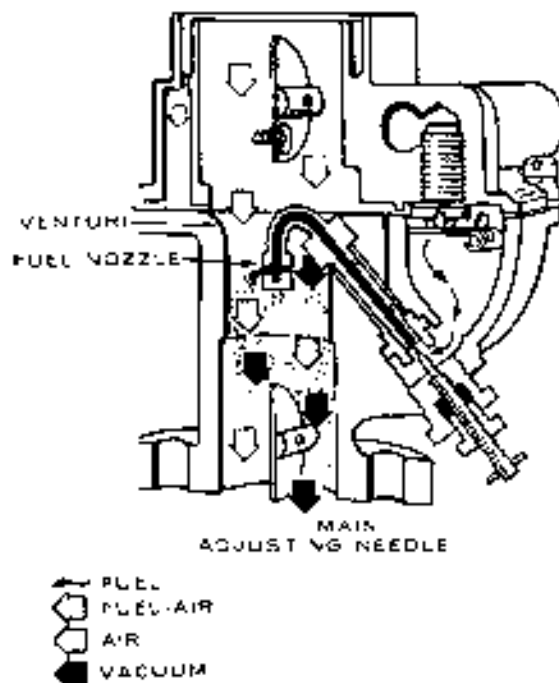

FIGURE 7-14. MAIN FUEL SUPPLY SYSTEM

Fuel entering the main jet, located at the bottom of the main well in the bowl, flows up through the main nozzle. Air from the high speed bleed channel enters the main well tube through a calibrated restriction at the top of the tube. Air passes through holes spaced along the tube, mixing the fuel as it flows up the main well. This fuel and air mixture, because it is lighter

Rev 10-75

than the straight fuel, responds faster to changes in venturi pressures. The mixture continues flowing up the main well, into the venturi where it is mixed with more air, and down into the cylinders for combustion.

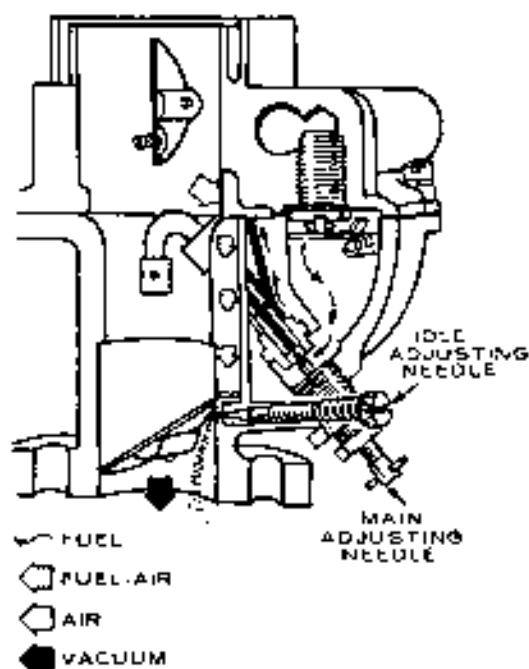

FIGURE 7-15. CARBURETOR IDLE SYSTEM

The idle system of the carburetor (Figure 7-15) functions when the engine is operating at low engine RPM or throttle position. It supplies the fuel-air mixture when the air flow past the carburetor venturi is insufficient to operate the main fuel system.

The range of the idle system operation may extend into the range of the main fuel system operation. Fuel flows from the main well up the idle well and through a calibrated jet. Filtered air from the carburetor air horn enters the idle bleed restriction and mixes with the fuel. The air bleed restriction also serves as a vent to prevent siphoning of fuel at high speeds or when the engine is shut off. The fuel-air mixture then passes down through an idle channel restriction and is transferred to the idle channel in the lower portion of the carburetor.

The fuel-air mixture passes down the idle channel, past two idle transfer holes, past the idle adjusting valve and is discharged below the throttle plate. The amount of mixture to be discharged is determined by the position of the idle screw needle in relation to its seat.

When starting an engine, a rich fuel to air mixture is desired. The carburetor choke should be closed to a point in relation to ambient and engine temperature (Figure 7-16). This choke setting then provides the necessary rich mixture.

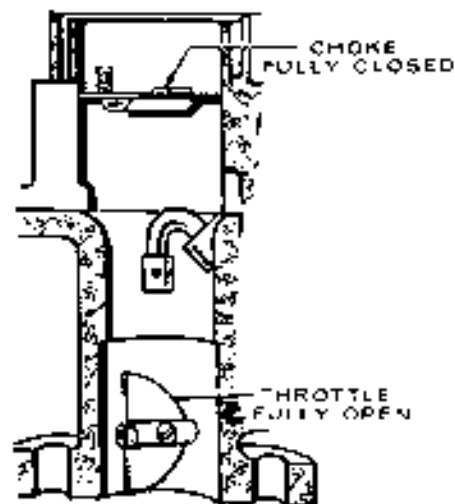

FIGURE 7-16. CARBURETOR CHOKE SETTING

Three types of choking methods are used on Onan engines: 1. manual, 2. electric, 3. bi-metal.

Manual chokes are controlled by the operator and must be continually supervised to ensure that the choke setting provides satisfactory engine performance. For detailed information on the electric and bi-metal chokes, see the automatic choke portion of this section.

Carburetor Removal and Installation

1. Remove air cleaner, fuel line, governor linkage and choke apparatus from carburetor.
2. Remove two carburetor mounting nuts and pull off carburetor (CCK engines require removing intake manifold to remove carburetor)
3. Reverse above steps to install carburetor on engine

Repair (See Figure 7-17)

1. Disassembly
 - a. Remove air cleaner adapter and choke from carburetor.
 - b. Remove main fuel adjustment needle and needle retainer.
 - c. Remove top of carburetor from carburetor base.
 - d. Remove carburetor float, lift out float valve and unscrew its seal.
 - e. Remove no load adjusting needle.
 - f. Remove throttle plate and throttle shaft.
 - g. Remove choke plate and choke shaft
 - h. Remove nozzle assembly.

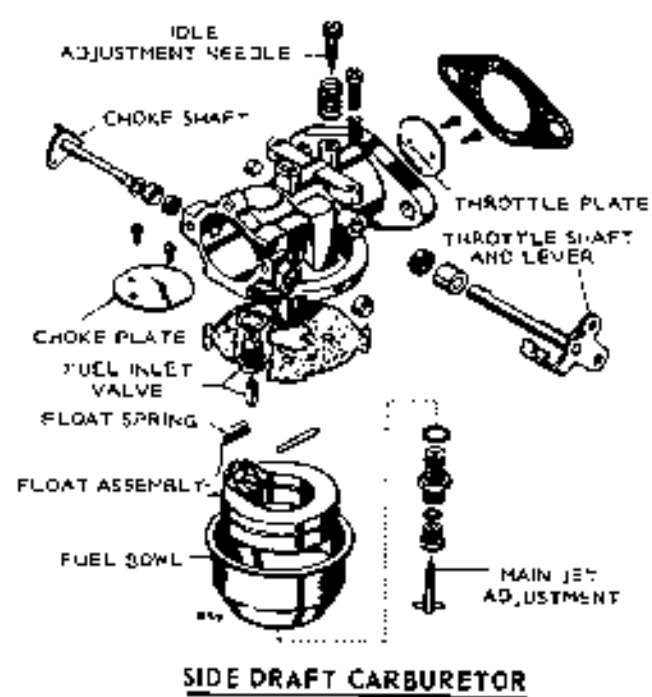
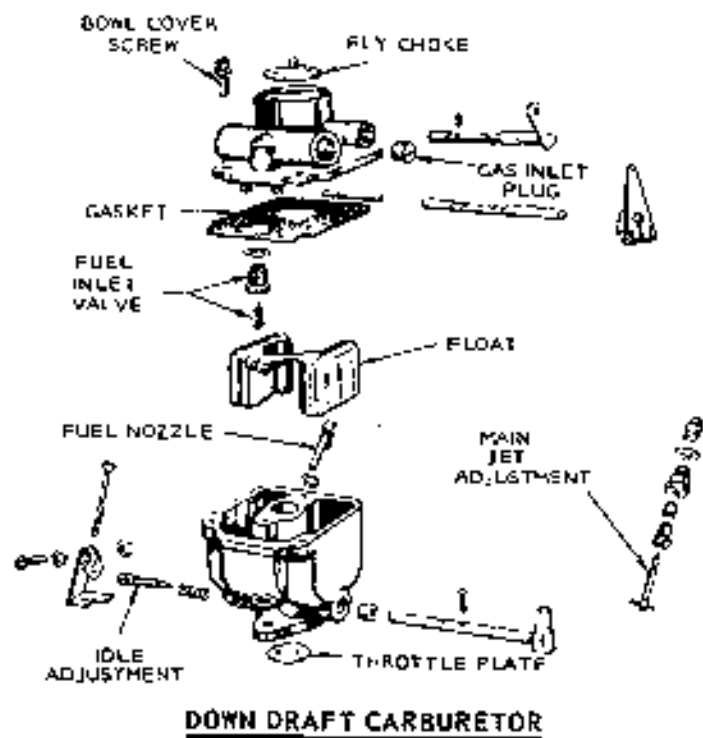

FIGURE 7-17. CARBURETOR ASSEMBLY

2. Cleaning and Repair

- a. Soak all components thoroughly in carburetor cleaner, following cleaner manufacturer's instructions. Clean all carbon from carburetor bore, especially in the area of the throttle valve. Blow out passages with compressed air. Avoid using wire to clean out passages.

- b. Check adjusting needles and nozzle for damage, Figure 7-18. If the float is loaded with fuel or damaged, replace it. The float should fit freely on its pin without binding. Invert carburetor body and measure float level.
- c. To adjust float level, bend small lip that needle valve rides on.
- d. Check choke and throttle shafts for excessive side play and replace if necessary.

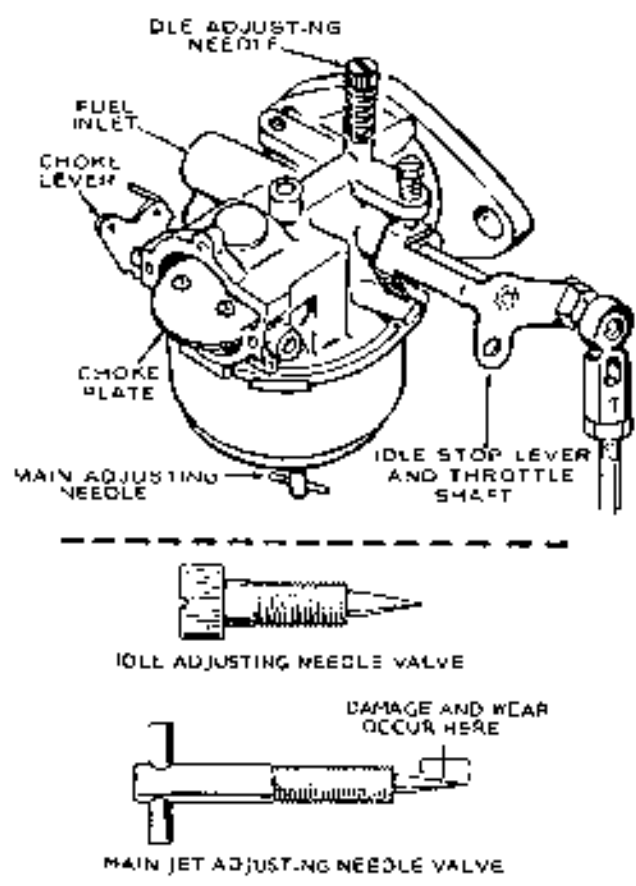

FIGURE 7-18. ADJUSTING NEEDLE INSPECTION

3 Assembly

- a. Install throttle shaft and valve, using new screws. The bevel on the throttle plate must fit flush with carburetor body. On valve plates marked with a "C," install them with the mark on the side toward idle port as viewed from flange end of carburetor. To center throttle valve (Bendix/Zenith Carburetor) back off stop screw, close throttle lever, and seat valve by tapping it with a small screwdriver, then tighten the two throttle plate screws.
- b. Install choke shaft and choke plate. Center choke plate in same manner as throttle valve. Always fasten plate in position with new screws.

- c. Install main nozzle, making sure it seats in body casting
- d. Install main fuel adjustment needle and its retainer.
- e. Install no load adjusting needle.
- f. Install intake valve seat and intake valve.
- g. Install float and float pin. Center pin so float bowl doesn't ride against it.
- h. Check float level.
- i. Install a new body-to-bowl gasket and secure the two sections together.
- j. Reinstall choke.
- k. Install air horn assembly.
- l. Install carburetor on engine.

Check the choke and throttle shafts for excessive side play and replace if necessary.

Carburetor repair and gasket kits are available from your nearest Onan Parts Center.

CARBURETOR DISASSEMBLY AND REPAIR (Figure 7-19)

Removal:

1. Remove air cleaner and hose.
2. Disconnect governor and throttle linkage, choke control and fuel line from carburetor.
3. Remove four intake manifold capscrews and lift complete manifold assembly from engine.
4. Remove carburetor from intake manifold.

Always work on carburetor in clean conditions.

Replacing Needle and Valve Seat:

1. Remove four screws from top of carburetor and lift off float assembly.
2. Invert float assembly as shown in Figure 7-20.
3. Push out pin that holds float to cover.
4. Remove float and set aside in a clean place. Pull out needle and spring.
5. Remove valve seat and replace with a new one, making sure to use a new gasket.
6. Install new bowl gasket.

BF ENGINE CARBURETOR

Carburetor Cleaning and Inspection

To clean the carburetor, soak all components thoroughly in a good carburetor cleaner, following the manufacturer's instructions. Be sure to remove all carbon from carburetor bore, especially in the area of the throttle. After soaking, clean out all passages with filtered, compressed air.

Check the adjusting needles and nozzle for damage. If float is loaded with fuel or damaged, replace it. The float should fit freely on its pin without binding.

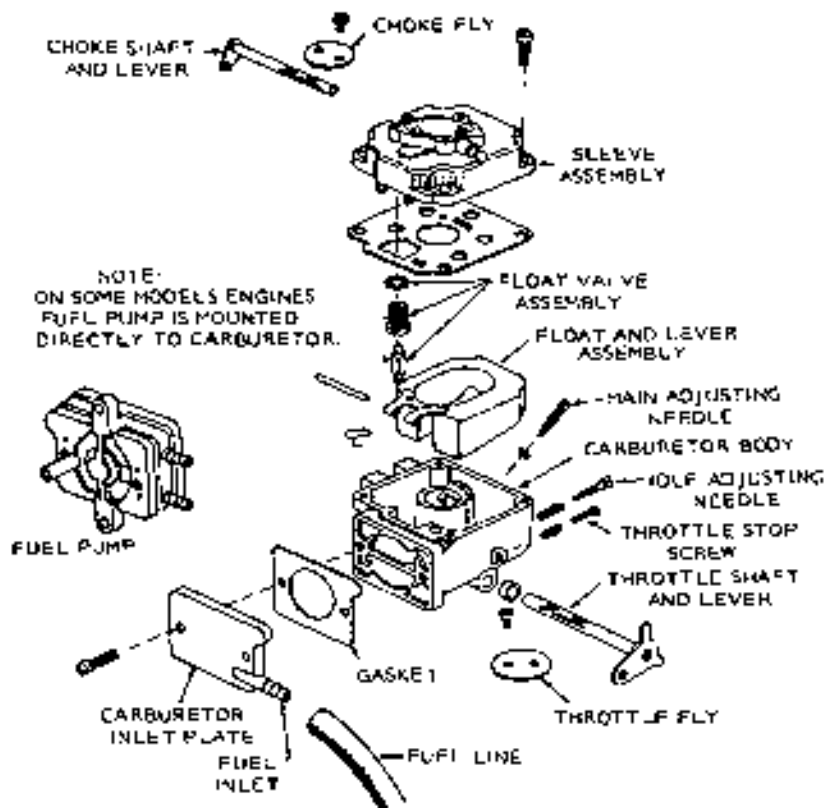

FIGURE 7-18. EXPLODED VIEW—BF ENGINE CARBURETOR

Rev 10-75

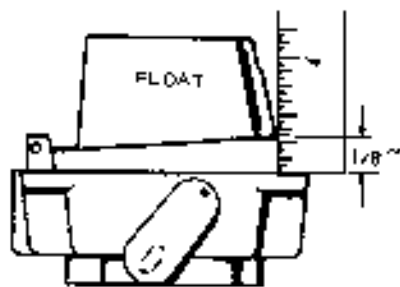

FIGURE 7-20. FLOAT ADJUSTMENT

7. Clip new needle to float assembly with spring clip. Install float.

Carburetor Float Adjustment:

1. Invert float assembly and casting.
2. With float resting lightly against needle and seat, there should be 1/8-inch clearance between bowl cover gasket and free end of float.
3. If it is necessary to reset float level, bend float tangs near pin to obtain a 1/8-inch (3.175 mm) clearance, Figure 7-20.

CARBURETOR OPERATION

The carburetor has a main fuel (high speed) adjustment and an idle fuel adjustment. The main adjustment affects operation under heavy load conditions (Figure 7-19). Idle adjustment affects operation under light or no load conditions. Under normal circumstances, factory carburetor adjustments should not be disturbed. If the adjustments have been disturbed, turn needles off their seats, 1 to 1-1/4 turn to permit starting. Then, readjust them for smooth operation.

CARBURETOR ADJUSTMENTS

The carburetor has a main fuel valve adjusting screw and an idle valve adjusting screw, Figure 7-21. A low speed adjustment screw is shown in Figure 7-22.

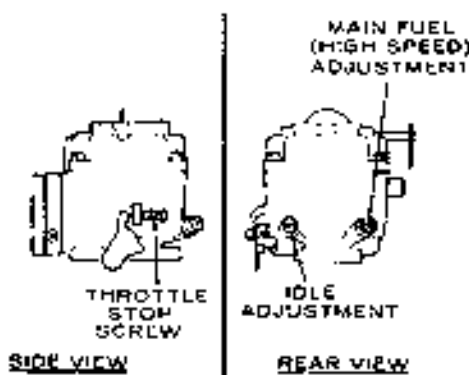

FIGURE 7-21. MAIN FUEL AND IDLE VALVE ADJUSTMENT

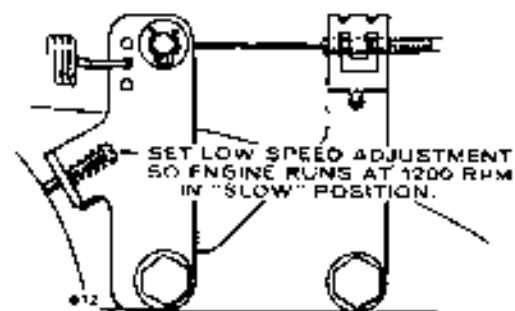

FIGURE 7-22. LOW SPEED ADJUSTMENT

Initial Adjustment:

1. Turn main fuel valve clockwise until it just closes.

CAUTION Valves may be damaged by turning them in too far.

2. Now open main fuel valve 1-1/8 turns counterclockwise.
3. Close idle valve in same manner and open it 1/2 to one turn (counterclockwise).
4. This initial adjustment will permit engine to start and warm up prior to final adjustment.

Final Adjustment:

1. Turn main fuel valve in until engine misses (lean mixture), then turn it out past point where engine runs smoothly until engine runs unevenly (rich mixture). Turn valve to mid-point between lean and rich so engine runs smoothly.
2. Hold engine at idle position and set low speed adjustment screw (Figure 7-22) until a fast idle is obtained (1200 rpm).
3. Hold throttle in idle position and turn idle adjustment valve in (lean) and out (rich) until engine idles smoothly.
4. Reset low speed adjustment screw so engine idles at 1200 rpm.
5. Release throttle—engine should accelerate without hesitation. If engine does not accelerate properly, readjust main fuel valve by turning out slightly.

Do not open main fuel valve more than 1/2 turn beyond maximum power point.

AIR CLEANER

CAUTION If air cleaner becomes too dirty, engine will not receive sufficient air causing loss of power, flooding, hard starting and overheating.

This engine is equipped with a paper element and a polyurethane pre-cleaner that must be removed, cleaned and oiled every 25 hours of operation, or more under extremely dusty conditions.

1. To clean pre-cleaner wash in water and detergent referring to Figure 7-23. Remove excess water by squeezing like a sponge and allow to dry thoroughly. Distribute three tablespoons of SAE30 engine oil evenly around pre-cleaner. Knead into and wring excess oil from pre-cleaner.

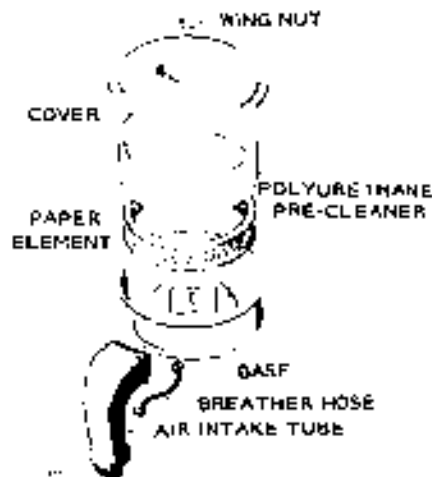

FIGURE 7-23. AIR CLEANER ASSEMBLY

2. Depending on conditions in which tractor is operating, inner paper element should be replaced whenever it becomes excessively dirty or oily

CAUTION Never run the engine with the air cleaner removed. Dirt will enter the engine and score the cylinders.

BF, NH POWER DRAWER CARBURETORS Carburetor Disassembly and Repair

Removal:

1. Disconnect fuel inlet hose, crankcase breather hose and air inlet hose, Figure 7-24.
2. Disconnect governor, throttle linkage, and choke control.
3. Remove two hold-down nuts and lift carburetor from intake manifold.

Always work on carburetor in clean conditions.

Replacing Needle and Valve Seat:

1. Remove 7/16-inch hex at base of fuel bowl and lift bowl from carburetor.
2. Push out pin that holds float to carburetor body.
3. Remove float and set aside in a clean place. Pull out needle and using a large screwdriver remove needle valve seat.
4. Install new valve seat and needle and replace float.
5. Adjust float.

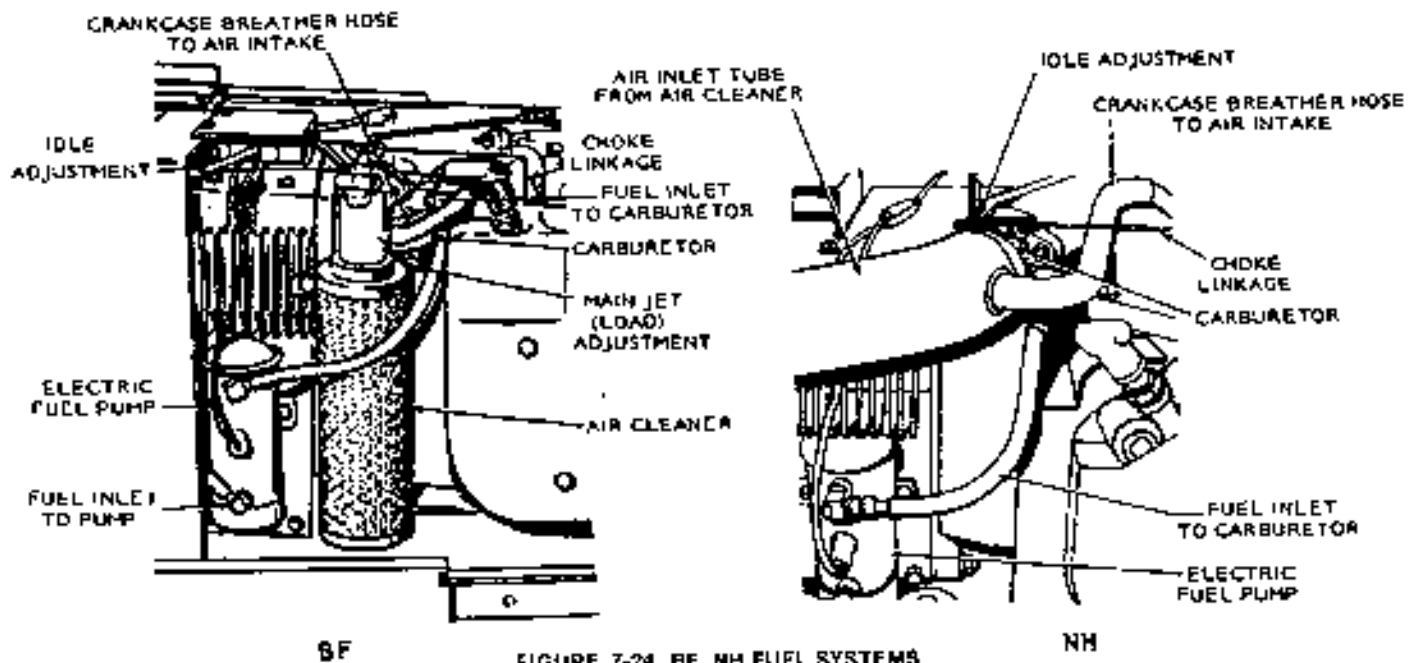

FIGURE 7-24. BF, NH FUEL SYSTEMS

Rev 10-75

CARBURETOR FLOAT ADJUSTMENT

1. Invert float and casting (Figure 7-25).
2. With float resting lightly against needle and seat, there should be .07-inch to .11-inch (1.8 to 2.8 mm) clearance between base of float and carburetor casting.

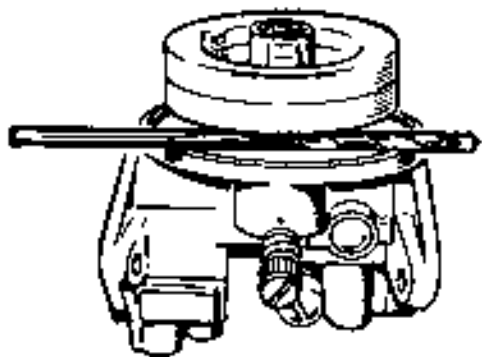

FIGURE 7-25. CARBURETOR FLOAT ADJUSTMENT

A drill bit can be used for this measurement. Use a 3/32-inch (2.38 mm) drill bit or any bit between .07-inch (1.8 mm), No. 50; and .11-inch (2.8 mm), No. 35.

3. If it is necessary to reset float level, remove float from carburetor and bend float tang near pin, to obtain correct float level.

CAUTION

Do not bend the float when installed; doing so may cause deformation of needle or seat.

4. Check float closely for signs of leakage. Repair or replace float if damaged or filled with gasoline.
5. Before assembling carburetor, remove filter screen from float bowl and clean both screen and base of float bowl.
6. Install new gaskets when reassembling.

CARBURETOR CLEANING AND INSPECTION

To clean the carburetor, soak all components thoroughly in a good carburetor cleaner, following the manufacturer's instructions. Be sure to remove all carbon from carburetor bore, especially in the area of the throttle. After soaking, clean out all passages with filtered, compressed air.

Check the adjusting needles and nozzle for damage. If float is loaded with fuel or damaged, replace it. The float should fit freely on its pin without binding.

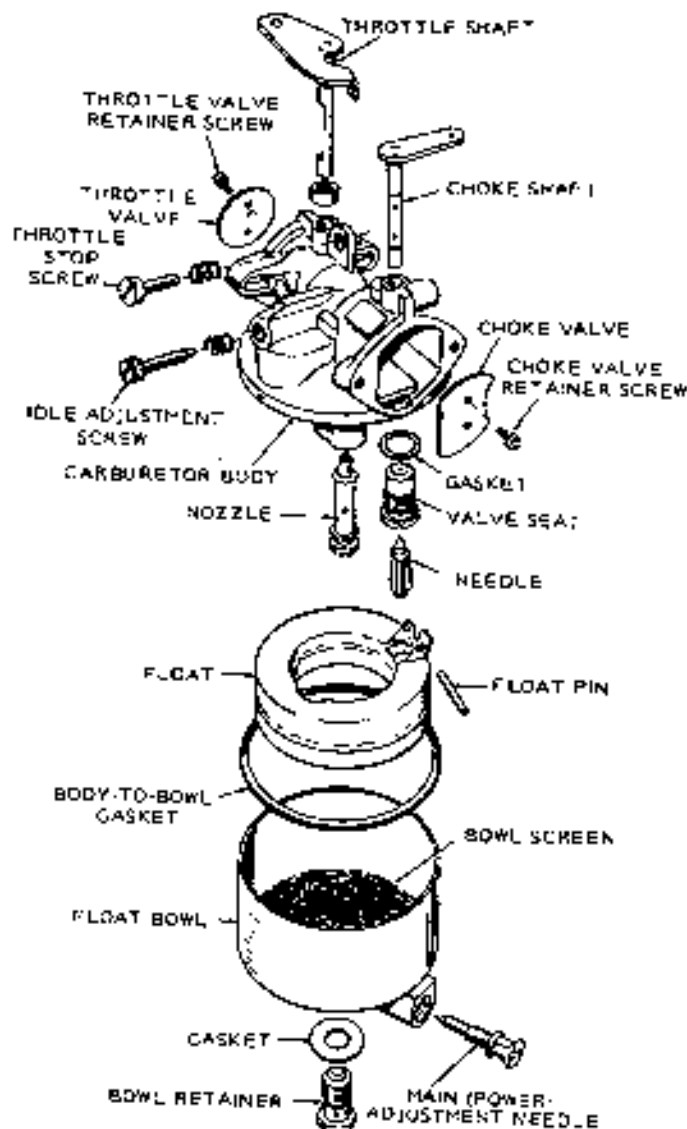

FIGURE 7-26. EXPLODED VIEW OF CARBURETOR

Check the choke and throttle shafts for excessive side play and replace if necessary. Figure 7-26 shows an exploded view of carburetor.

FUEL PUMP FILTER ELEMENT

Every 400 hours or sooner, drain fuel pump and check filter element (Figure 7-27). Remove fuel pump mounting screws and turn off hex nut on base of pump. If element appears dirty, replace with a new one. Be sure to replace gaskets when reassembling.

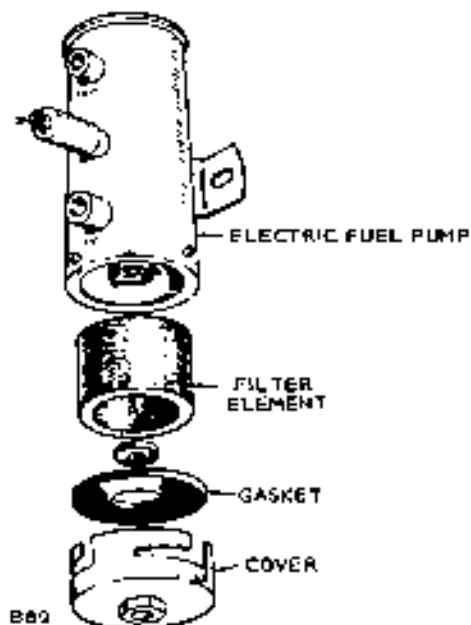

FIGURE 7-27. FUEL PUMP FILTER ELEMENT

FUEL SOLENOID

An electric fuel solenoid (Figure 7-29) mounts between fuel pump outlet and carburetor inlet. The solenoid opens during cranking and running. A defective solenoid will not allow engine to start.

CARBURETOR BOWL

Remove carburetor bowl every 500 hours and clean filter screen in solvent. Blow out with low pressure compressed air and reassemble, making sure gaskets are in place.

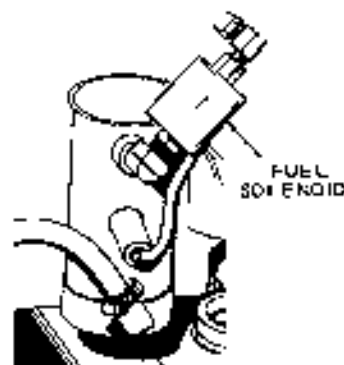

FIGURE 7-29. FUEL SOLENOID

AIR CLEANER ELEMENT

Check and clean element at least every 100 hours. Loosen wing nut to remove (Figure 7-28). Clean by lapping base lightly on a flat surface. Replace element at least every 500 operating hours. Clean or replace more often in dusty conditions.

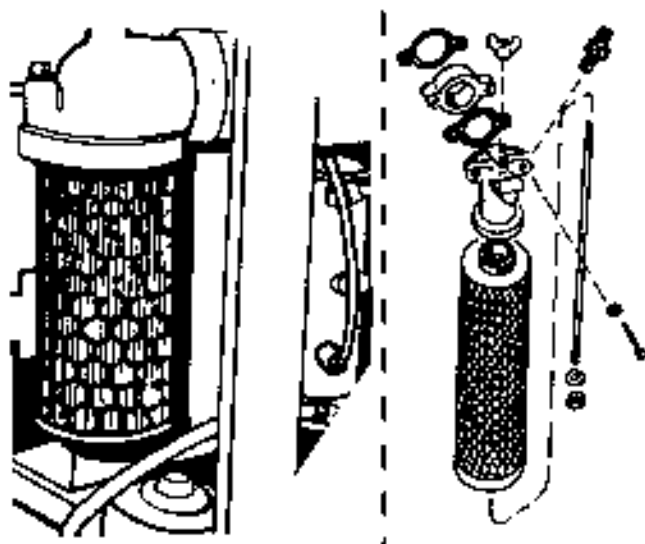

FIGURE 7-28. AIR CLEANER ELEMENT

GOVERNOR BALL JOINT

Every 200 hours or sooner, check the governor linkage for freedom of movement through its travel. Clean and lubricate ball joint with lubricating graphite, Figure 7-30.

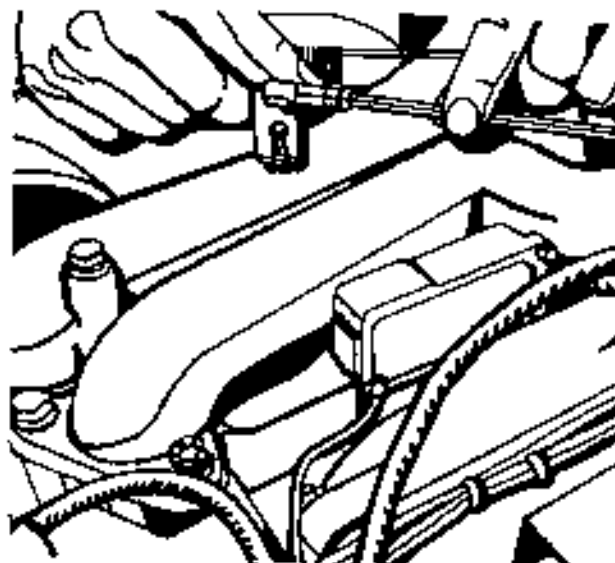

FIGURE 7-30. GOVERNOR BALL JOINT

Rev 10-75

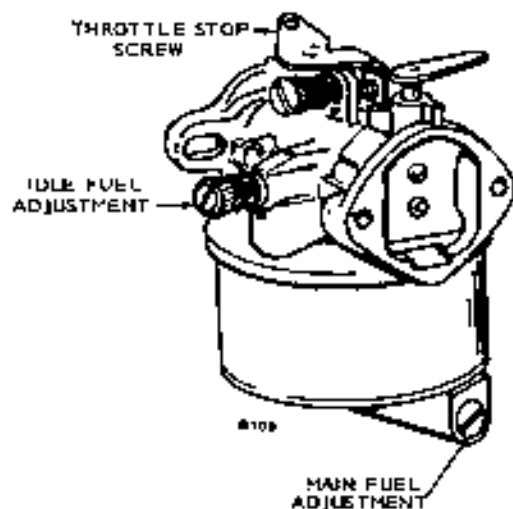

FIGURE 7-31. CARBURETOR ADJUSTMENTS

CARBURETOR ADJUSTMENTS

The carburetor has a main fuel (power) adjustment and an idle fuel adjustment, Figure 7-31. The main adjustment affects operation under heavy load conditions. Idle adjustment affects operation under light or no load conditions. Under normal circumstances, factory carburetor adjustments should not be disturbed. Normal settings are 1-1/4 turn open for main fuel jet and one turn open for idle fuel jet.

CAUTION Forcing the needle against its seat will damage it. The needle does not completely shut off fuel when turned fully in.

Before final adjustment, allow the engine to warm up. Make the idle adjustment under no load. Open the main jet until the engine runs smooth under acceleration with no load. Slightly more fuel may be needed (open about 1/4 turn further) when sudden load is applied or if operating in very cold weather.

Set the throttle stop screw (located on carburetor throttle lever) with no load connected and while running at a low speed setting. Turn the screw to give approximately 1/32 inch (0.79 mm) clearance between the screw and pin.

If the engine develops a "hunting" condition (alternate increase and decrease of engine speed), try correcting by opening the main adjusting needle a little more. Do not open more than 1/2 turn beyond the maximum power point.

VACUUM SPEED BOOSTER

Use a fine wire to clean the small hole in the short vacuum tube which fits into the hole in the top of the engine intake manifold (Figure 7-32). Do not enlarge this hole.

If there is tension on the external spring when the generator set is operating at no load or light load, it may be due to improper adjustment, restricted hole in the small vacuum tube, or a leak in the booster diaphragm or gasket.

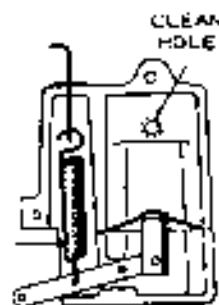

FIGURE 7-32. VACUUM SPEED BOOSTER

AUTOMATIC CHOKES

General

Automatic chokes are used on engines and generating sets which are started by remote or automatic control. Automatic chokes operate to close the carburetor choke valve when the engine is started cold and to gradually open the choke valve as the engine warms up. In this way, the proper gasoline and air mixture is provided for starting "cold" and during the warmup period.

If difficulties of readjustment result from extreme starting temperatures, check the OPERATOR'S MANUAL for your specific model.

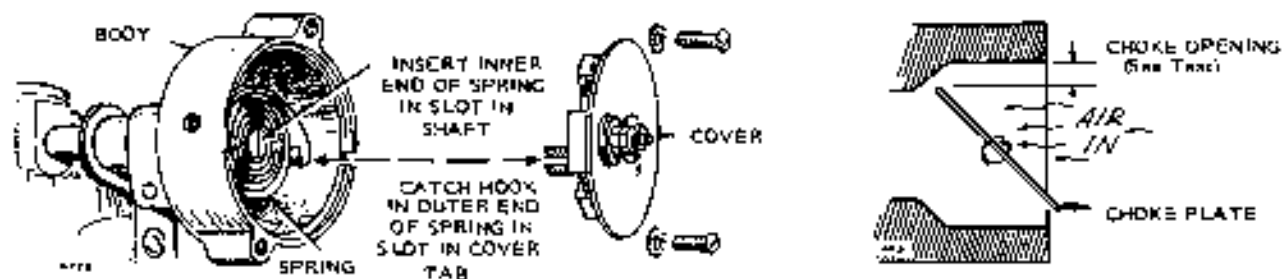

FIGURE 7-33. CHOKE ADJUSTMENT

Directions for adjusting the various chokes are given in the following pages. Several adjustments may be necessary in order to arrive at the correct adjustment. Let the engine cool off to the ambient air temperature between each adjustment.

Automatic chokes must be adjusted to provide the correct fuel and air mixture for starting the engine under various temperature conditions. If it starts, then stops after running a few seconds, the choke mixture may be too lean. If it starts, then runs rough and is sluggish after beginning to warm up, the choke mixture may be too rich.

Bi-Metal Coil

Figure 7-33 illustrates the bi-metal coil choke actuated by an electric heating element. Two different designs of this choke have been used.

This choke is mounted directly on the carburetor choke shaft boss. Its bi-metal coil may spiral either clockwise or counterclockwise inward from its fastening screw depending upon the carburetor used.

The inner end of the bi-metal coil engages the carburetor choke shaft. Carburetor choke is offset slightly on the shaft. A manual operating knob is usually provided on the opposite end of the choke shaft. The bi-metal coil is adjusted so that when the engine is "cold", the choke valve is nearly closed at the position which provides the proper starting mixture. As the engine starts, the increased force of air against the longer side of the choke valve tends to push it open against the tension of the bi-metal coil. The fluttering action resulting can be seen at the manual operating knob.

As the engine starts and warms up, current from the generator exciter is supplied to the electric heating element in the cover. Heat from the element causes the bi-metal coil to twist. The twisting action of the coil turns the shaft, gradually opening the valve. Heat from the element is sufficient to keep the choke open while the engine is running.

To adjust the choke shown in Figure 7-33, loosen the two mounting screws which secure the cover to the brackets. Refer to Table 7-1.

TABLE 7-1. CHOKE SETTINGS

ENGINES	AMBIENT TEMP.	CHOKE OPENING	
		INCHES	METRIC
CCK, AJ,	58	1/4 open	6.35 mm
AK, LK	66	1/2 open	12.70 mm
	76	3/4 open	19.05 mm
	82	open	open

Choke Setting

A clockwise rotation of the choke cover on the following models will give a richer mixture: JA, JB, JC, MJA, MJB, MJC, AJ, 2.5MAJ, AK, LK.

A counterclockwise rotation of the choke cover on the following models will give a richer mixture: CK, CCK, MAJ (all except 2.5MAJ).

Set the choke opening on early models (to Spec C) JA, JB, JC, MJA, MJB, MJC and RJC according to the local air temperature (ambient temperature). Different temperatures require a larger or smaller choke opening for maximum efficiency.

Loosen the choke cover screws (Figure 7-33) and check the choke opening by measuring the distance from the edge of the choke to the inside of the carburetor throat. Turn the choke cover **CLOCKWISE** to decrease or **COUNTERCLOCKWISE** to increase the choke opening according to Table 7-2.

Turn only approximately 1/8 inch (3.175 mm), then check by starting the engine. Let the engine cool off thoroughly between trials. Be sure to retighten the clamp screw after adjusting the choke.

TABLE 7-2. CHOKE OPENING DIMENSIONS

AMBIENT TEMPERATURE (Degrees F)		68	72	76	80	84	88	92	96	100
CHOKE OPENING (INCHES)	M, A, JA	1/64	3/64	1/16	3/32	7/64	1/8	9/64	13/64	13/64
	MJB, JB	3/16	7/32	1/4	9/32	5/16	11/32	3/8	13/64	1/16
	RJC, MJC, JC	0	1/64	3/64	1/16	3/32	7/64	1/8	9/64	11/64

During installation of a new heating element, check the voltage rating of the element for correctness. Late series choke covers use a stamped number and the early series use a color code to identify the various voltage ratings. Refer to Table 7-3 for voltage rating or stamped number identification.

When installing a new bi-metal coil, maintain the original direction of spiral inward from the fastening screw. Be sure the coil sets squarely in the housing so it will not bind.

If the electrically heated choke fails to operate, check to see there is current at the cover terminal. The engine must be running. The cover should become hot after a few minutes of operation. If there is current, check to see that the voltage of the heating element (see color code, Table 7-3) corresponds to the DC voltage of the set shown on the nameplate. See that the heating element is not burned out or broken. The bi-metal coil must not be damaged, not dragging in the housing nor the spiral improperly directed. Check for binding of the carburetor choke shaft or choke and correct if necessary.

TABLE 7-3. CHOKE VOLTAGE RATINGS

NUMBER	COLOR	VOLTAGE	ONAN PART NUMBER
6	YELLOW	6-8	153-0050, 153-0112
12	RED	12-16	153-0049, 153-0113
24	BLUE	24-28	153-0051, 153-0114
28	GREEN	28	153-0162
32	WHITE	32-40	153-0052, 153-0115
40	NOCOLOR	40	153-0116 Ungrounded 153-0330

For units other than the J series, set the choke wide open (but not under tension) at about 80°F (27°C) and check engine starting and running.

Thermal Magnetic

This choke uses a strip heating element and a heat sensitive bi-metal spring to control the choke position. A solenoid, actuated during engine cranking, closes the choke all or part way depending on ambient temperature. The bi-metal is calibrated to position the choke to proper opening under any ambient condition. Adjustment must be made with the bi-metal at ambient temperature. Do not attempt adjustments until the engine has been shut down for at least one hour. Loosen the screw which secures the choke body assembly. Refer to Figure 7-34 for the correct choke setting according to temperature. Use a drill rod or the shank of a drill to measure the choke opening. Rotating the choke body clockwise richens and counterclockwise leans the choking effect. Tighten the screw that secures the choke body.

If the choke does not operate or will not maintain its adjustment, disassemble it for repair. If it will not open, check for heating. Remove the choke cover and feel the insulating washer when the engine is running. It should be warm if the heater is working properly.

If the choke will not heat properly, check for a broken heater wire, high resistance connection or broken lead wires to the bi-metal and heater assembly. With the element at room temperature, check the heater resistance with an ohmmeter. The resistance should be about 30.6 to 37.4-ohms for a 12 volt system. If the heater is defective, replace it with a new one. When

AMBIENT TEMP (°F)	60	65	70	75	80	85	90	95	100
CHOKE OPENING (Inches)	1/8	9/64	5/32	11/64	3/16	13/64	7/32	15/64	1/4



FIGURE 7-34. CHOKE SETTING

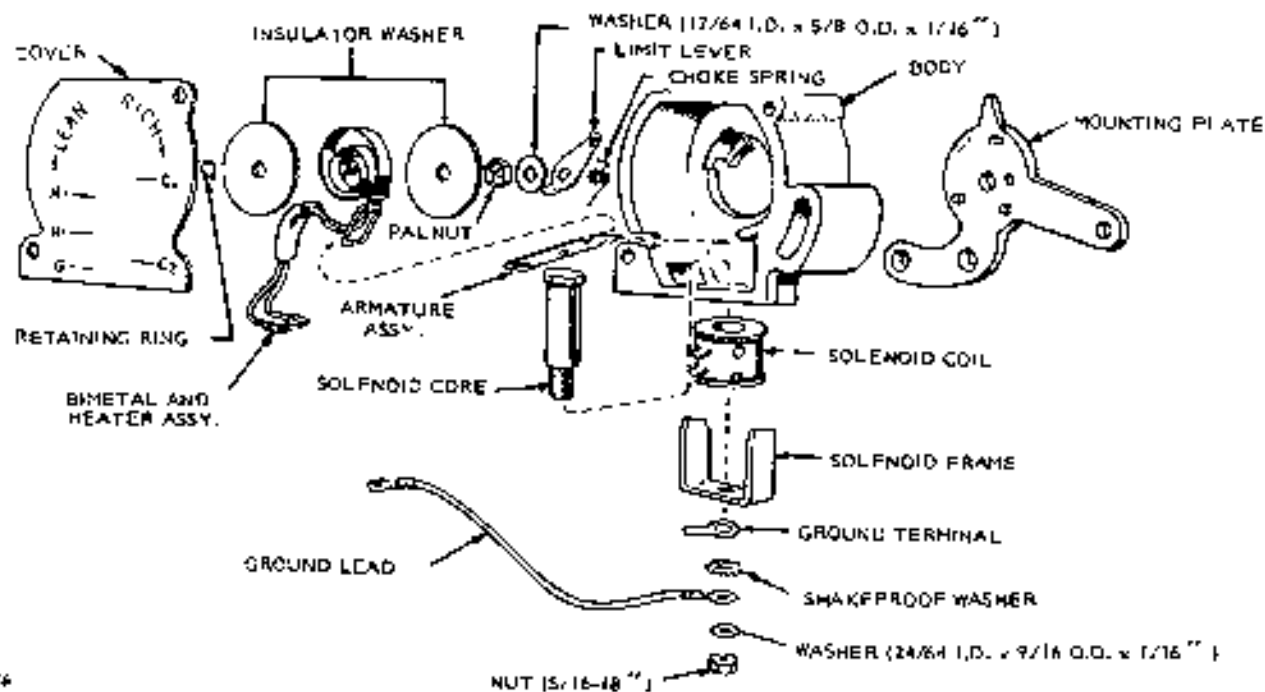

FIGURE 7-35. THERMAL MAGNETIC CHOKE

The start button is engaged, the solenoid should cause the spring-loaded armature to contact the solenoid core. If this does not occur, check for broken lead wires or a defective solenoid coil. There must be slack in the lead wires between the choke body and the bi-metal and heater assembly. The solenoid coil should have a resistance of 2.09 to 2.31-ohms in a 12 volt system, Figure 7-35.

When assembling the thermo-magnetic choke (Figure 7-35), connect the bi-metal and heater assembly as follows: lead tagged G to ground terminal on coil solenoid, lead tagged H to either of the H1 terminals on the solenoid core.

Electric Solenoid

The electric solenoid choke is of Sisson manufacture. Sisson chokes are used on some Onan engines and electric generating sets and are a combination of magnet and bi-metal.

The electric solenoid type of choke is shown in Figure 7-36. The magnetic coil and core assembly A is mounted at the top of the assembly. The hinged magnet arm B is connected by link C to a U-shaped bi-metal strip bears against the shaft plate E which operates the shaft F. Choke lever G is mounted on shaft F and is connected by suitable linkage to the carburetor choke lever.

When the start button on the engine is pressed, the magnet arm B is pulled upward. If the engine is being

started "cold", the bi-metal strip D is spread enough so that the lever C will move far enough to completely close the carburetor choke. This gives a rich choking mixture for starting. As soon as the engine starts and the start button is released, the magnet arm B drops down to a position determined by the bi-metal strip D opening the carburetor choke slightly. As heat from the manifold affects the bi-metal strip D, its ends come closer together, permitting the choke to open still wider. When the engine is started at operating temperature, the bi-metal strip ends are close together, preventing the magnet arm from pulling the shaft plate upward.

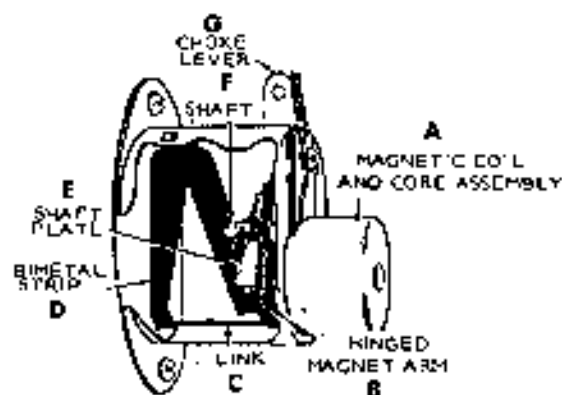

FIGURE 7-36. ELECTRIC SOLENOID

This choke should require no seasonal readjustment. If the adjustment has been disturbed, adjust in the following manner. The engine should be "cold." Disconnect the linkage to the carburetor choke shaft. Rotate the choke lever G in the closed choke direction until the hole in shaft F is aligned with the notch in the shaft bearing. Insert a 1/16-inch (1.59 mm) diameter rod through the shaft hole, engaging the rod in the notch of the mounting flange. This will lock the shaft in place.

Loosen the choke lever clamp screw enough to permit moving the lever on the shaft. The linkage to the choke lever must be properly in place. Remove the air cleaner connection from the carburetor air intake so that the choke can be seen. Adjust the choke assembly lever so that the carburetor choke is just closed or not more than 1/16-inch (1.59 mm) open. Tighten the choke lever clamp screw and remove the locking rod from the shaft.

Test the adjustment to see that when the choke lever is pulled upward to its limit, the choke is closed or nearly so. Press downward on the choke lever against the tension of the bi-metal strip to the limit of its travel. The choke should open completely. If the choke will not open completely, adjust the position of the choke shaft lever as necessary. Recheck the adjustment. If trial proves further adjustment is necessary, reinsert the locking rod and loosen the lever clamp screw. For a richer choke mixture, pull the lever upward slightly. For a leaner choke mixture, push the lever downward slightly.

Tighten the clamp screw and remove the rod from the shaft hole. When the engine is at operating temperature, the choke must be wide open.

The choke cannot operate properly if there is any binding in the connecting linkage, the choke assembly shaft or the carburetor shaft. To test the magnet of the choke assembly, hold a screwdriver blade 1/4 inch (6.35 mm) from the top center riveted post. When the start button is pressed, the magnet coil should be energized, pulling the screwdriver to the center post. If no magnetic pull is felt, check the choke electrical circuit. Replace the choke if the magnet coil is defective.

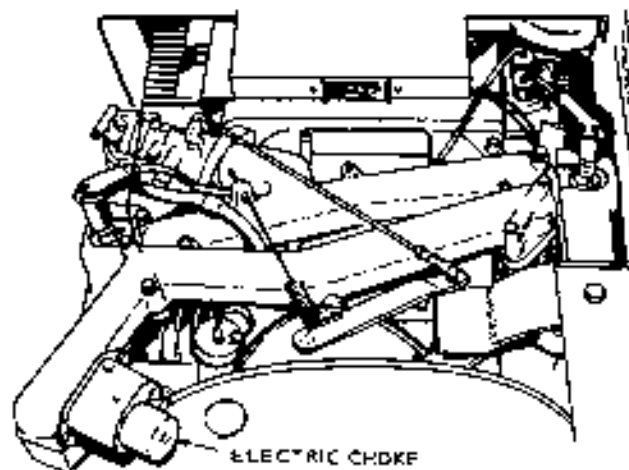

FIGURE 7-37. ELECTRIC CHOKE

Electric Choke BF, NH POWER DRAWER

Manually check movement of choke travel (Figure 7-37) to be sure it is not stuck open or closed. Voltage at choke should be 12 volts during start and drop to zero during run. If choke does not move at room temperature with 12 volts applied, replace.

This choke should not require any seasonal readjustment. If adjustment becomes necessary proceed as follows:

1. Remove clip and bushing.
2. Loosen choke lever clamp screw.
3. With lever fully forward (away from carburetor), adjust so choke valve is completely closed.
4. Tighten clamp screw.
5. Replace bushing and clip.

AIR CLEANER TYPES

Air cleaners remove dirt, dust and foreign particles from the carburetor intake air without reducing the airflow to the carburetor. Check the air cleaner every 100 hours of operation or more often when operating in extremely dusty or dirty conditions. A plugged air cleaner restricts intake air causing poor engine operation and excessive fuel consumption.

Onan uses one of three types of air cleaners:

- Oil Bath Air Cleaner, Figure 7-38 .
- Moistened Foam Air Cleaner, 7-39.
- Dry Paper Element Air Cleaner, Figure 7-40.

Oil Bath Air Cleaner: The oil bath air cleaner is remotely mounted with a flexible tube connecting the oil cup to the carburetor intake. This kind of cleaner uses clean crankcase oil and a wire screen filter element to remove dirt, lint, etc. from the air. Clean the sump and add new oil at each oil change.

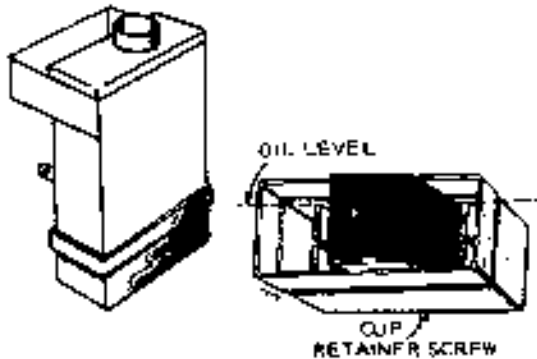
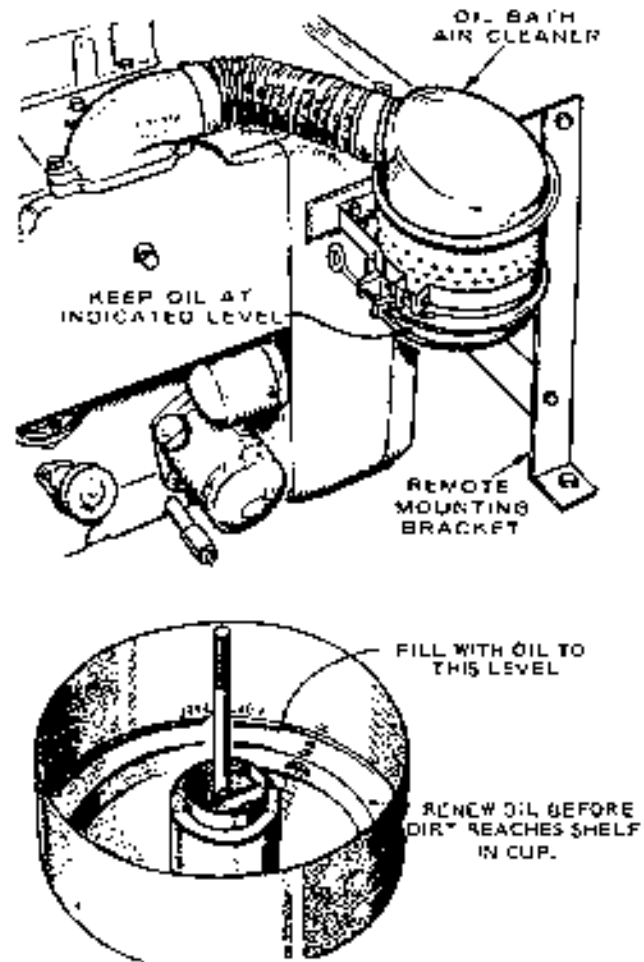

FIGURE 7-38. OIL BATH AIR CLEANERS

Moistened Foam Air Cleaner: This air cleaner consists of a synthetic sponge over a metal retainer. The base and cover are similar to those of the dry paper kind. Wash the sponge periodically, moisten in oil and squeeze dry

AFTER WASHING ELEMENT IN SOLVENT DIP IN ENGINE OIL AND SQUEEZE AS DRY AS POSSIBLE

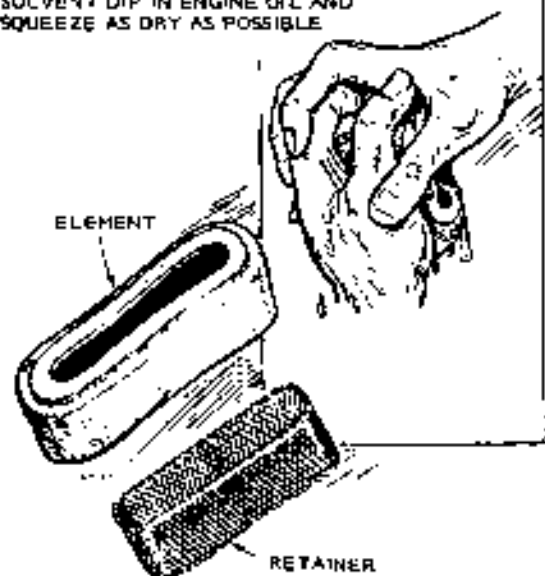
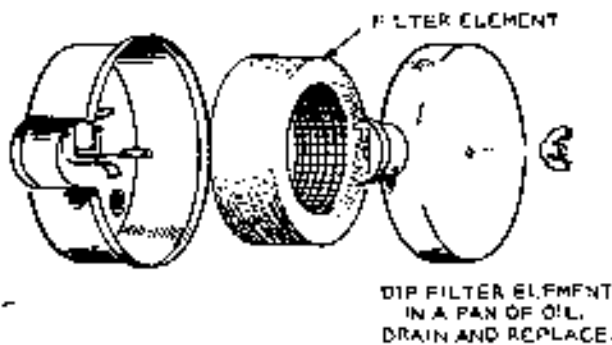
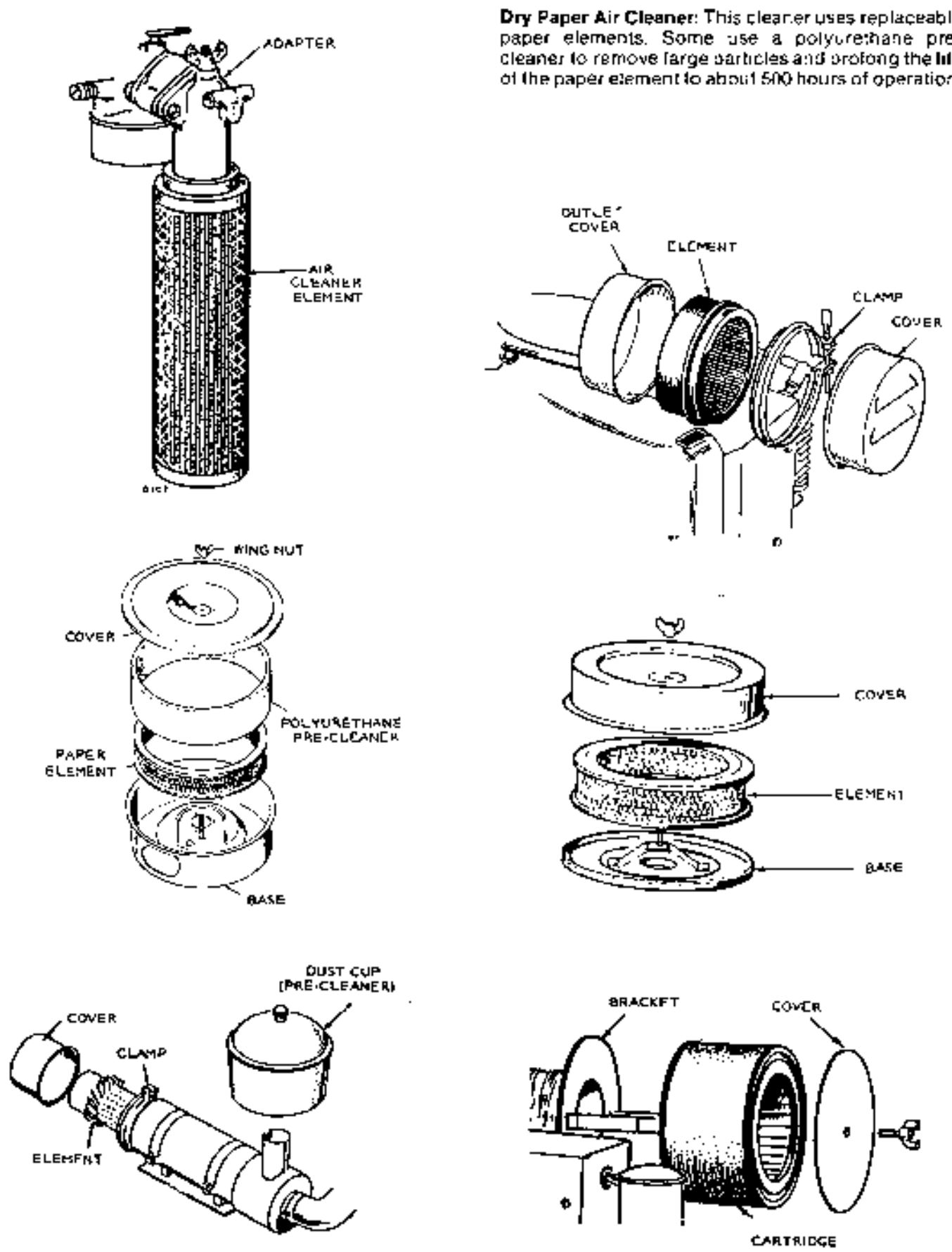

FIGURE 7-39. MOISTENED FOAM AIR CLEANERS

Rev 10-75



Dry Paper Air Cleaner: This cleaner uses replaceable paper elements. Some use a polyurethane pre-cleaner to remove large particles and prolong the life of the paper element to about 500 hours of operation.

FIGURE 7-40. DRY PAPER AIR CLEANER

Ray-10-75

SECTION 8. FUEL SYSTEM — GASEOUS

INDEX

SAFETY PRECAUTIONS WHEN WORKING WITH LPG.....	8-1
CARBURETOR (GAS)	8-1
GAS AS A FUEL.....	8-1
Operation	8-1
Adjustment.....	8-2
Removal and Disassembly	8-2
Repair and Assembly	8-2
IMPCO CARBURETOR (30 kW and up).....	8-2
CARBURETOR (GAS/GASOLINE).....	8-3
GASEOUS FUEL REGULATOR—OPERATION	8-3
Testing	8-4
Gas Regulator (Atgas)	8-4
Gas Regulator (Garretson).....	8-5
Solenoid Primer	8-5
Course Adjustment	8-5
Primer Test	8-6
Regulator Repair	8-6
EQUIPMENT ON CLASS B GENERATOR SETS.....	8-6
LPG Flame Heated Vaporizer.....	8-6
LPG Engine Mounted Vaporizer	8-8
LPG Air Heated Vaporizer.....	8-7
Vaporizer Adjustments	8-7
Vaporizer Service.....	8-8
IMPCO FUEL SYSTEMS	8-8
Fuel	8-9
Fuelcock and Filter	8-9
Vaporizer Coil	8-9
Regulator	8-9
Gas Carburetor.....	8-9
Carburetor Operation	8-10
Carburetor Adjustments.....	8-11
Initial Start Adjustments	
(at Factory or After Service or Maladjustment)	8-11
Checking Fuel at Carburetor	8-11
Carburetor Adjustments Without Exhaust Analyzer	8-11
Idle Screw and Idle Stop Adjustment	8-11

Carburetor Adjustments with Exhaust Analyzer.....	8-11
Main Power Adjustment.....	8-11
Idle Screw Adjustment.....	8-11
Throttle Stop Adjustment.....	8-12
TABLE 8-1. GAS-GAS/GASOLINE FUELED UNITS.....	8-1
TABLE 8-2. GASOLINE TO GASEOUS FUEL ADJUSTMENTS.....	8-4
TABLE 8-3. INLET PRESSURE TO SECONDARY REGULATOR.....	8-4
TABLE 8-4. VAPOR PRESSURES OF LP GASES.....	8-6

SAFETY PRECAUTIONS WHEN WORKING WITH LPG

1. Always close LPG tank shut-off valve when engine is left unattended between use.
2. Be sure LPG tank shutoff valve is closed before disconnecting tank from system.
3. Ignition switch must be in OFF position prior to disconnecting any electrical wires.
4. Check fuel system regularly for leaks. Use soap to locate leaks and recheck with soap after repairing leaks.
5. Keep a fire extinguisher handy for immediate use. A dry powder or carbon dioxide (CO₂) type is recommended.
6. Never use LPG for cleaning parts.
7. Do not use LPG near open flame. Work in a well ventilated area.

LPG is heavier than air and settles in low places.

CARBURETOR (Gas)

The gaseous fuel carburetor is similar to the gasoline model in size and shape, but differs in operation. The basic gas carburetor used on Onan units has two major sections, the idle circuit and the load circuit. See Table 8-1 for a listing of gas or gas-gasoline operated Onan engines.

TABLE 8-1.
GAS-GAS/GASOLINE FUELED UNITS

SERIES	GAS ONLY	GAS/GASOLINE
AK	X	X
AJ	X	X
LK	X	X
CCK	X	X
CCKA	X	X
CCKB	X	X
NH	X	X
NHA	X	X
NHB	X	X
NHC	X	X
BF		
NB	X	X
JB	X	X
JC	X	X
RJC	X	X

GAS AS A FUEL

Refer to Onan Technical Bulletin T-015 "Use of Gaseous Fuel with Onan Electric Generating Sets" for a detailed description and comparison between natural, manufactured, and Liquid Petroleum gases.

Onan recommends that HD-5 grade propane (95 percent propane) be used in the Onan LPG engines. Onan also recommends that natural or manufactured gases be at least 1000 BTU content for maximum efficiency, with a minimum of service.

Consult a reputable local gas distributor and NFPA (National Fire Protection Association) Pamphlet 58 for more specific information.

For additional information, refer to Onan Technical Bulletin T-015.

OPERATION

Fuel delivery depends on the demand created on the fuel inlet line of the carburetor, Figure 8-1. A small vacuum on the inlet line opens the fuel regulator, thus delivering fuel. (For a detailed description of carburetor operation see Section 7 of this manual.) For no load operation, the idle adjustment controls the quantity of fuel allowed through the idle port. The throttle is almost closed so increased vacuum on the engine side of the carburetor draws fuel through the idle passage. As the load increases, the flow of air through the carburetor draws fuel from the main fuel port located at the venturi.

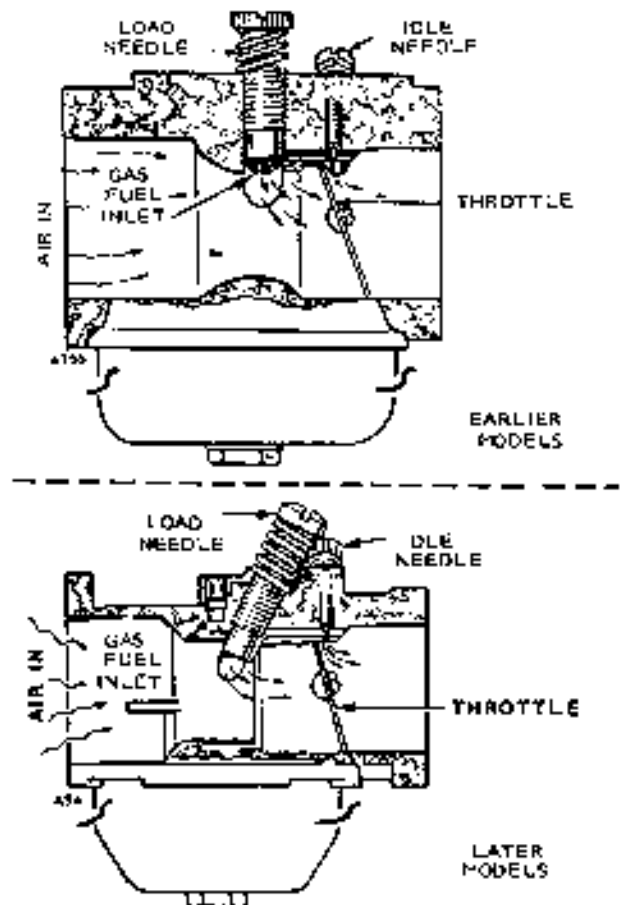

FIGURE 8-1. FUNCTIONAL DIAGRAM

Rev 10-75

Follow factory recommendations for timing as natural gas burns relatively slow. Late timing results in power loss, excessive heating of the exhaust valves and high exhaust stack temperatures. Propane requires a retarded spark setting from that specified for natural gas under load because the burning rate is faster than that of natural gas.

CAUTION With no vaporization of liquid fuel in the cylinder to help cool the valves during intake and compression cycles, excessive exhaust temperatures may burn or reduce the life of exhaust valves.

Gas fuel operation requires heavy duty spark plugs.

Adjustment

Set the carburetor gas idle adjustment and the gas load adjustment. Figure 8-2.

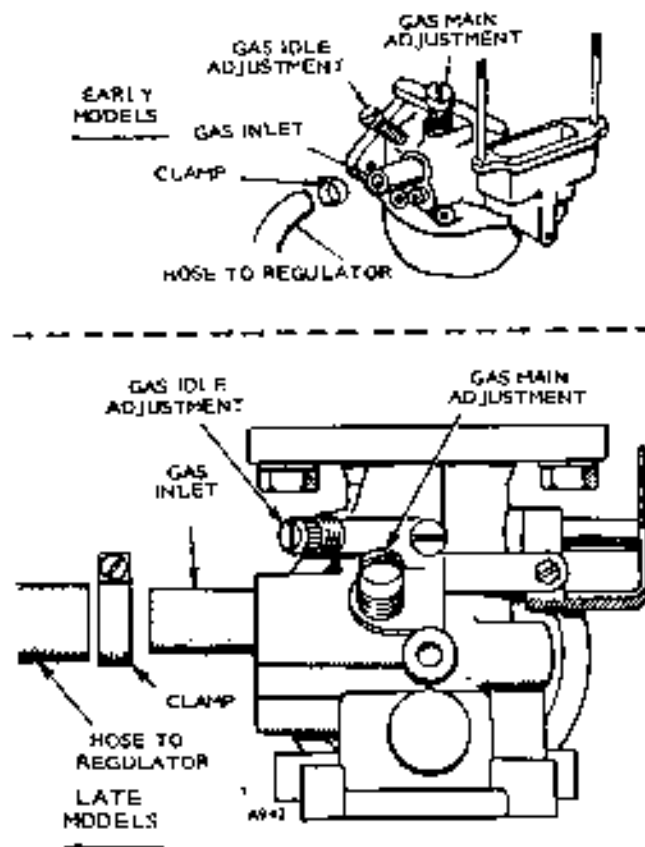

FIGURE 8-2. CARBURETOR ADJUSTMENT

If the carburetor is completely out of adjustment and the engine cannot be started, turn the idle and main adjustments into their seats. Open the idle adjustment between one and two turns. Crank the engine while opening the main adjustment until the engine starts.

Adjust the carburetor in the same manner as adjusting a gasoline carburetor (see Section 7 of this manual). Usually the idle adjustment will have little effect on high speed operation at which the engine is usually operated.

Removal and Disassembly

1. Remove fuel line and governor linkage from carburetor.

WARNING

Make sure the gas is turned off before disconnecting the fuel line to the carburetor.

2. Remove two carburetor mounting nuts and take off carburetor.
3. Remove float bowl.
4. Remove idle adjustment screw and main adjustment screw.
5. Remove throttle screws and plate and pull out throttle shaft.

Repair and Assembly

Clean the carburetor in a suitable cleaning solvent and blow out the idle passage. Check the idle needle for wear or damage and the main adjustment for worn threads. To assemble the carburetor, reverse the disassembly procedure.

IMPCO CARBURETOR (30 kW and up)

The Impco carburetor is available on Onan electric generating sets 30 kW and larger. See Figure 8-3. With the Impco carburetor, the gas pressure at the carburetor must be set at 3 ounces (5-inch water column) with the engine running at 1800 rpm at no load. If the pressure is excessive, adjust the Thermac regulator. Be sure to comply with all local regulations such as:

- Recommended electric shutoff valve
- Hand shutoff valve at fuel source
- Supply line filter

Use a short length of approved flexible connection between the supply pipe and the regulator inlet.

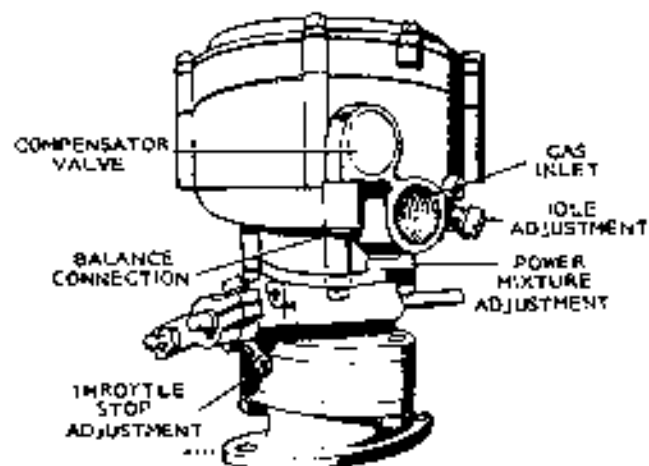

FIGURE 8-3. IMPCO CARBURETOR

Rev 10-75

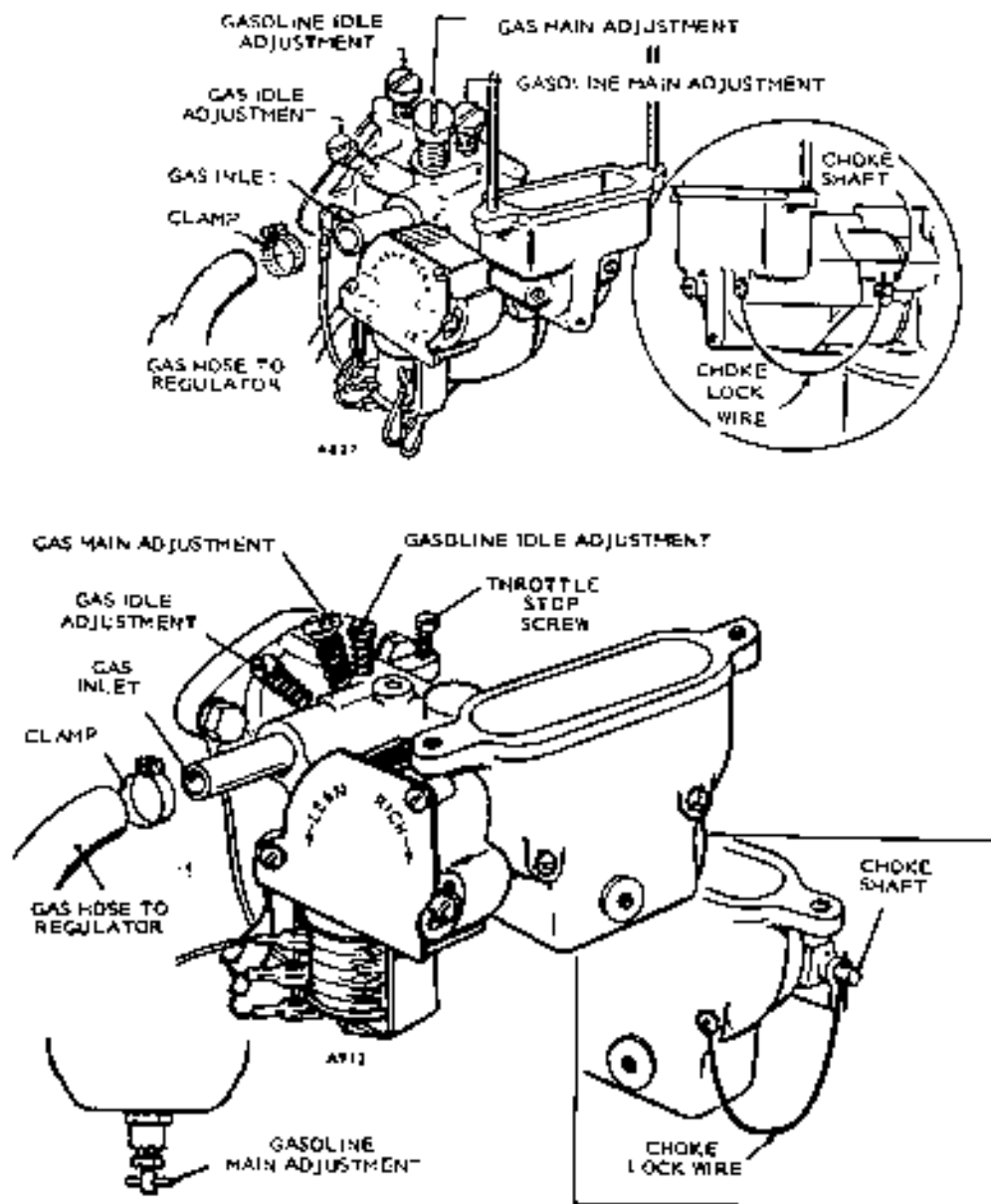

FIGURE 8-4. GAS/GASOLINE CARBURETOR AND ADJUSTMENT

CARBURETOR (Gas/Gasoline)

The gas/gasoline carburetor (Figure 8-4) functions on either gasoline or gaseous fuels. This carburetor consists of both a gas and gasoline carburetor on the same casting. Refer to Section 7 of this manual for information concerning the function of a gasoline carburetor and to the gas carburetor portion of this section for information concerning the operation of a gas carburetor. To switch carburetor operating fuels, follow the adjustment procedures detailed in Table 8-2.

GASEOUS FUEL REGULATOR—OPERATION

A demand type regulator (secondary regulator) opens on a small vacuum from the engine. It supplies fuel on demand and shuts off fuel flow when the engine is stopped. The regulator is a diaphragm with a linkage connecting it to a valve in the regulator. Vacuum from the engine moves the diaphragm, opening the delivery valve. Onan has used two models of regulators, the Algas regulator (earlier models) and the Garretson regulator (later models).

A primary regulator is required whenever the supply pressure is greater than the demand or secondary regulator can withstand, usually 8 ounces (.22 kg).

TABLE 8-2. GASOLINE TO GASEOUS FUEL ADJUSTMENTS

MODIFICATION	TO GASOLINE	TO GASEOUS FUEL
Gas supply valve	Close	Open
Carburetor float and needle valve	Replace if removed for gas	Remove if for extended operation on gas — reduces wear
Choke	Remove lock wire	Install lock wire
Spark plug gap	Set at .025" (.635 mm)	Set at .018" (.457 mm)
Gasoline fuel supply valve	Open	Close

**TABLE 8-3. INLET PRESSURE TO SECONDARY REGULATOR
(Straight Gaseous Fuel Only)**

MODEL	PRESSURE	MODEL	PRESSURE	MODEL	PRESSURE	MODEL	PRESSURE
AJ, AK, AH, CC, CCKB, JB, JC, RJC (Begin Spec F)	2 oz. to 6 oz. (.6 to .17 kg)	JC RJC (Spec A thru N)	6 oz. to 5 psi (.17 to 34.5 kg)	EK, FM	12 oz. (.34 kg) maximum (to thermac)	KB, KR, WA, WB, FT	12 oz. (.34 kg) maximum (to thermac)
						WF, WK*	20 psi (1.58 kg)

* - Usually only require one regulator (see text).

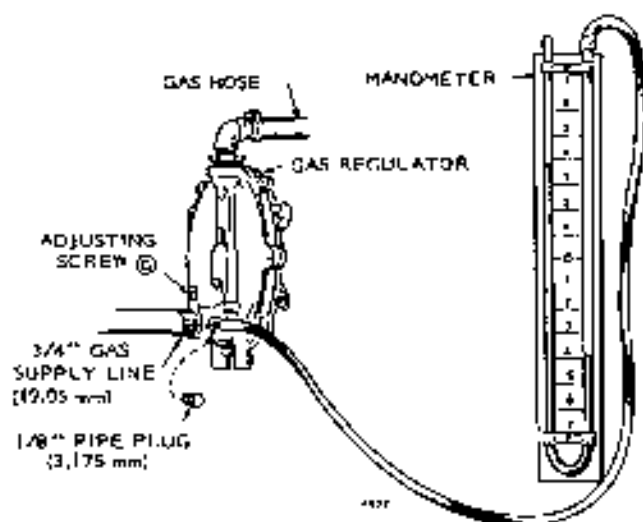

Testing

Blow into the diaphragm vent hole on the regulator cover; this should open the valve. An audible hiss indicates that the regulator is opening.

Use a water manometer for testing regulator inlet pressure, Table 8-3. (Inlet pressure must be within the limits specified for your regulator.) Use the chart in Figure 8-5 to convert the difference in water inlet between the two tubes to pressure in ounces.

CAUTION A soap bubble placed over the regulator outlet will not accurately test for regulator closing. The bubble's resistance when multiplied by the greater area of the regulator diaphragm, is enough to shut off this very sensitive demand type regulator.

kPa	OZ.	INCHES OF WATER*
0.431	1	1.7 — 43.9 mm
0.862	2	3.5 — 87.8 mm
1.293	3	5.2 — 131.7 mm
1.724	4	6.9 — 175.3 mm
2.155	5	8.7 — 220.9 mm
2.586	6	10.4 — 264.1 mm
3.018	8	13.8 — 350.5 mm
4.310	10	17.3 — 439.4 mm
5.172	12	21.0 — 533.4 mm
6.034	14	24.0 — 609.6 mm
6.896	16	28.0 — 711.2 mm

* - Indicates equivalent of water level difference in ounces

Gas Regulator (Algas)

The Algas regulator has no adjustments and features a positive lock-off if pressure increases above the regulator setting. Maximum inlet pressure is 5 psi (34.5 kPa) and minimum, 6 ounces (2.59 kPa).

The standard Onan supplied solenoid shut-off valve, #307-0312, locks off at a gas inlet pressure at 6 ounces (.22 kg). An optional valve is available with pressure rating to 5 psi (34.5 kPa), Figure 8-6.

FIGURE 8-5. REGULATOR TESTING

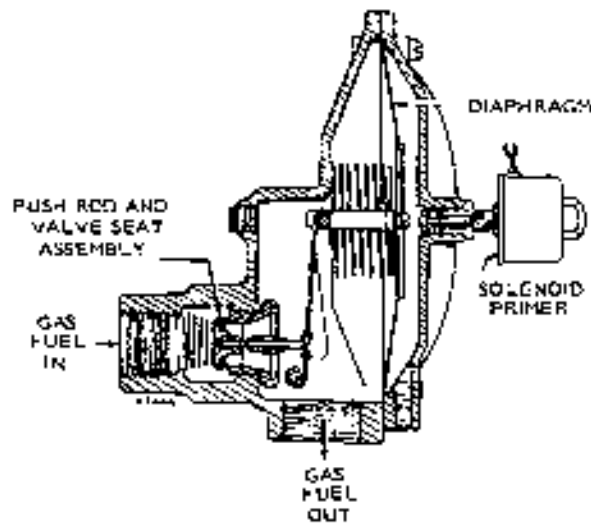

FIGURE 8-6. ALGAS REGULATOR

Gas Regulator (Garretson)

The maximum allowable inlet pressure is 8 ounces (.22 kg); minimum 2 ounces (.6 kg). If gas line pressure is greater than 8 ounces (.22 kg), install a primary regulator to reduce the pressure. The regulator has an adjustment to control the maximum pressure at which the regulator shuts off when there is no demand. To obtain maximum regulator sensitivity, adjust it to just shut off at your line pressure when there is no demand to prevent gas leaks. The factory adjusted shutoff is between 2 and 4 ounces (.6 and .11 kg). If gas line pressure is between 4 and 8 ounces (.11 and .22 kg), readjust the screw, Figure 8-7.

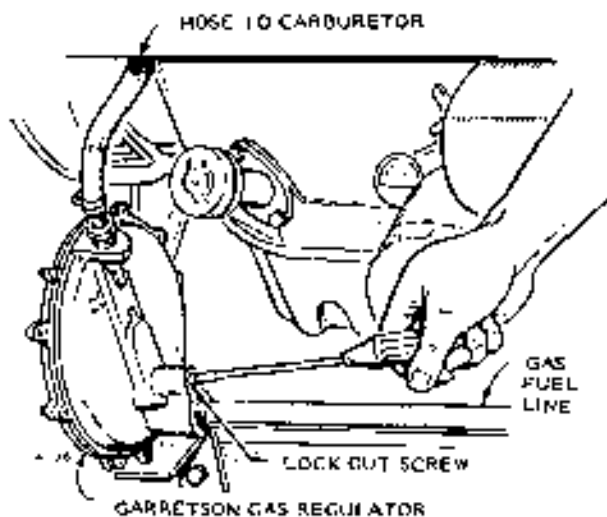

FIGURE 8-7. GARRETSON REGULATOR

To adjust the regulator, the gas line should be connected and the outlet hose removed. Make a coarse adjustment by turning the adjusting screw inward until the hissing of escaping gas at the outlet stops. Install a water manometer on the inlet side of the regulator to make the fine adjustment. With the gas on, cover the regulator outlet for a few seconds and then open. If the regulator is leaking, the pressure shown on the manometer will drop slightly or waver, indicating that the valve is opening. Turn the screw inward slightly and repeat the test. Continue until the manometer holds steady as the outlet is closed for a few seconds and then opened.

Solenoid Primer (Algas Regulator Only)

Algas regulators use an optional solenoid primer to provide quick engine starting. The primer (Figure 8-8) holds the regulator open during engine cranking. It can be adjusted for a rich or lean mixture by loosening the lock nut and turning the primer in or out. Turning the primer clockwise richens the mixture.

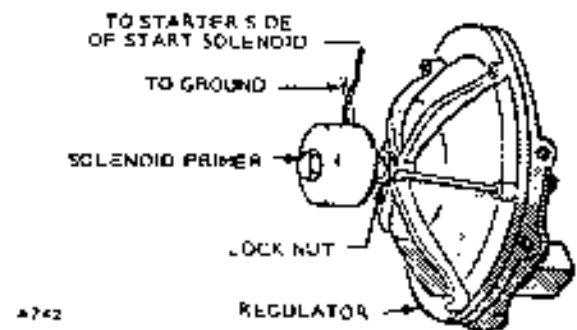

FIGURE 8-8. SOLENOID PRIMER

To adjust for proper priming of a cold engine, set the primer so a hot engine (one with gas in the regulator-carburetor hose and the carburetor) sounds slightly rough and produces slightly dark exhaust when the engine first starts firing.

Coarse Adjustment

1. Remove regulator-carburetor hose at regulator and apply battery voltage across primer.
2. Turn primer clockwise (richer) until you can hear a small flow of gas at outlet.
3. Remove voltage, connect hose and attempt to start engine.
4. If engine starts within 3 seconds, primer is correctly adjusted. If not, remove hose at regulator and crank engine for a few seconds to empty hose and carburetor of gas and readjust primer slightly.
5. Connect hose and attempt to start. Continue until engine starts within 3 seconds from an empty hose and carburetor.
6. When primer is properly adjusted, be sure regulator locks off when unit is stopped.

Primer Test

To test the primer, remove it from the regulator, noting the number of turns necessary to unscrew it and operate the start switch. The plunger must extend out. The wiring or primer solenoid may be defective or the plunger is stuck in the primer body.

Regulator Repair

If the regulator does not deliver fuel, check inlet pressure. If inlet pressure is within the required limits and the regulator won't deliver fuel or leaks, disassemble it for repair.

To disassemble regulator, carefully remove cover and separate the diaphragm from cover and body. A kit is available from Onan to repair the regulator.

If this regulator appears defective; won't open, won't close or delivers insufficient fuel, check the shut off pressure adjustment. A kit is available from Onan to replace both the diaphragm and valve.

EQUIPMENT ON CLASS B GENERATOR SETS

LPG Flame Heated Vaporizer

The LPG tank supplies liquid fuel to the vaporizer. LPG is actually a liquid under pressure of an average of 70 or more pounds per square inch depending on temperature. When released from this pressure, LPG easily volatilizes under normal temperatures depending on the actual content of the gas. Refer to Table 8-4 for temperature-pressure relationships. The vaporizer transforms the liquid fuel to a gaseous state and reduces the high tank pressure to a low outlet pressure of 3 psi (.08 kg).

The gas flows from the vaporizer to the inlet side of the regulator. Pressure is slightly greater than that of the vaporizer outlet pressure of 3 psi.

The throttle and venturi of the carburetor create a low vacuum when the engine is running. The regulator senses the vacuum and allows fuel to flow in proportion to the need.

The idle jet port is located in the area of the venturi. The pressure being lower than that of the regulator's 3 psi pressure setting allows fuel to flow into the carburetor by means of the idle jet port for starting and idling.

As the throttle opens, the vacuum decreases at the idle jet port. Fuel is then drawn through the larger high speed jet port and engine speed increases.

During gaseous fuel operation, one of the more critical adjustments is the valve tappet clearance. Be sure to check clearances frequently and adjust as required (while cold).

LPG Engine Mounted Vaporizer

Liquefied petroleum gas-fueled engines are equipped with a vaporizer system combined with a pressure-reducing regulator. Use only approved materials and methods to connect to the supply source. Install a liquid fuel filter in the supply line and an electric solenoid valve. An emergency hand shutoff valve should be provided.

Models shipped after June 15, 1967 have the Thermac pressure reduction valve installed upside down. When changing from natural gas to LPG vapor withdrawal, remove the spring and replace items 1 and 2, Figure 8-9. This valve now becomes a negative regulator or a zero pressure valve for vaporized propane. Pressure reduction is not needed with propane fuel.

TABLE 8-4. VAPOR PRESSURE OF LP-GASES

TEMPERATURE		APPROXIMATE PRESSURE (PSIG)			
		PROPANE		BUTANE	
(F)	(C)	PSI	(kPa)	PSI	(kPa)
-40	-40.0	3.6	25		
-30	-34.4	8.0	55		
-20	-28.9	13.5	93		
-10	-23.3	20.0	138		
0	-17.8	28.0	193		
10	-12.2	37.0	255		
20	-6.7	47.0	324		
30	-1.1	58.0	400		
40	4.4	72.0	497	3.0	21
50	10.0	86.0	593	6.9	48
60	15.6	102.0	704	11.5	79
70	21.1	120.0	828	16.5	114
80	26.7	140.0	966	22.0	152
90	32.2	165.0	1139	29.0	200
100	37.8	190.0	1341	37.0	255
110	43.3	220.0	1548	46.0	317

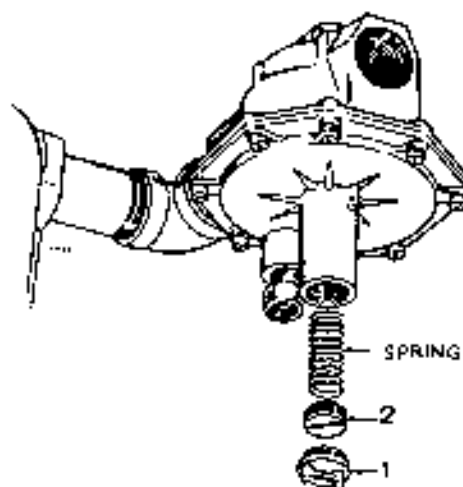

FIGURE 8-9. REGULATOR SPRING REMOVAL

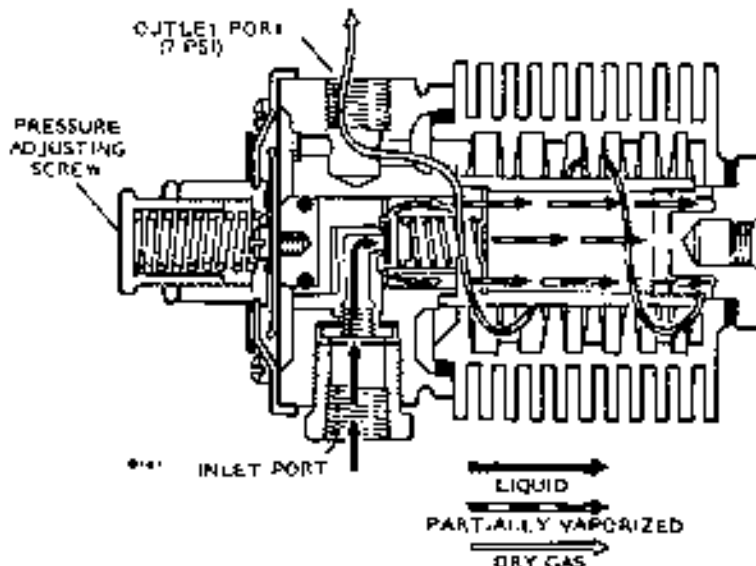
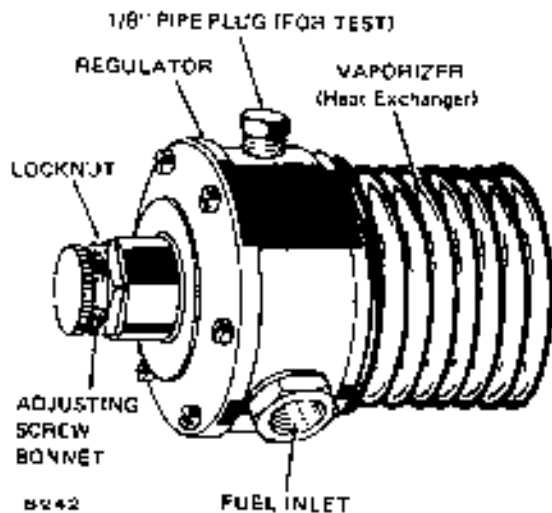

FIGURE 8-10. VAPORIZER-REGULATOR

The following points must be considered when choosing between a liquid withdrawal system and a vapor withdrawal system:

- The size of actual electric generating set for determining amount of fuel required.
- The ambient temperature for determining amount of fuel vaporization.

Generally, Class B units that are 85 kW and larger require an external side arm vaporizer and do not operate on the liquid withdrawal system.

LPG AIR HEATED VAPORIZER

The vaporizer-regulator consists of a high pressure regulator and vaporizer in a single unit, Figure 8-10. The regulator portion of the vaporizer-regulator reduces LPG tank pressure to a uniform outlet pressure of 7 psi. The vaporizer section installed in the path of the engine cooling air system furnishes the heat required to offset the cooling effect produced as the LPG fuel expands and becomes gas.

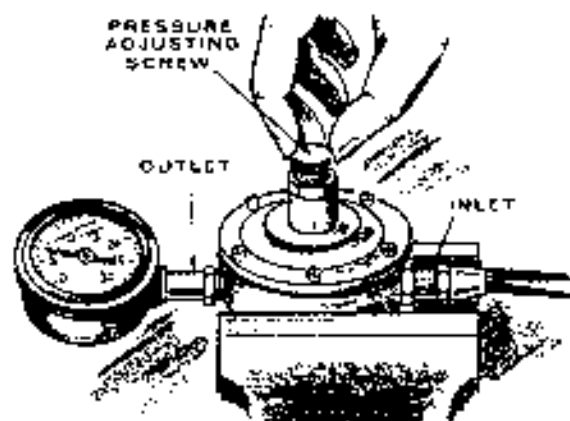

FIGURE 8-11. VAPORIZER ADJUSTMENT

The vaporizer reduces high pressure liquid fuel to low pressure gaseous fuel. Liquid fuel is admitted into the inlet port and passes through the fuel inlet or orifice. With the engine running, the pressure to the right of the valve seat and retainer drops to open the valve, a mixture of partially vaporized fuel enters the center tube (first stage cold chamber) of the vaporizer. The droplets of fuel are sprayed out of the end plug holes into the staggered portions of the cast heat exchanger. The swirling action of the fuel ensures complete vaporization. Dry gas leaves the exchanger through the outlet port at 3 psi.

Vaporizer Adjustments

Adjust the vaporizer to a working pressure of 7 psi whenever the pressure adjusting screw is moved or the unit is overhauled.

1. Place vaporizer in a vise or another suitable clamp. Attach an air hose from an air supply of 75 psi to inlet, Figure 8-11.
2. Attach a 0-10-30 or 0-10-50 psi pressure gauge to outlet.
3. Back off adjusting screw until only one or two threads are engaged. Apply air pressure to unit.
4. Turn pressure adjusting screw in slowly until a reading of 7 psi shows on gauge.

To obtain an accurate gauge reading, it may be necessary to partially unscrew gauge bleeding off some of the air. Then retighten gauge and readjust for 7 psi. If gauge indicator remains steady, the valve is not leaking. If pressure reading increases slowly, it indicates a leaking valve. Check the components of the vaporizer for correct assembly procedures. Replace defective parts.

5. Tighten lock nut on pressure adjusting screw. Turn off air pressure and remove gauge and air line.

Vaporizer Service

To repair the vaporizer, proceed as follows:

1. To free a sticking O-ring, take vaporizer out of casting by loosening tie bolt two or three turns. Tap lightly on tie bolt and on vaporizer head until O-ring water seal works free.
2. Check pressure with at least 60 psi air pressure at vaporizer inlet bushing.
 - a. Use a pressure gauge in vaporizer outlet which allows accurate readings in 3 to 10 psi range.
 - b. If vaporizer has only one gas outlet, connect a 1/4" pipe tee.
 - c. If second outlet has 1/8" pipe plug, remove it and set pressure adjusting bonnet to give a reading of 10 psi with no flow (thumb over 1/8" outlet).
 - d. The gauge should read 3 to 5 psi when 1/8" IPT test hole is open allowing full air flow and should return 7 to 10 psi with hole covered.
 - e. Erratic readings or creeping pressure readings mean that the vaporizer must be serviced.
3. Low pressure during flow test means valve is failing to open properly.
3. Soap or immerse unit in water to check for gas leaks around O-ring, gasket in base, and diaphragm.

If the test hole is 1/4" IPT instead of 1/8", drill a 3/16" hole in the center of a 1/4" pipe plug. Using this test orifice, perform the flow test above. This should give a 3 to 5 psi reading at 10 psi shutoff pressure.

All the above tests are useless if the pressure is below 60 psi.

IMPCO FUEL SYSTEMS

A typical liquid withdrawal LP gas fuel system consists of a vacuum fuel lock and filter, a vaporizer, a fuel regulator, and a gas carburetor connected by flexible hoses. Figure 8-12A. A pulse balance line is needed for one and two cylinder engines between the carburetor and regulator. A vacuum line is needed between the intake manifold and the fuel lock and filter. Some systems have a vacuum or solenoid operated fuel cutoff valve or both; the solenoid operated valve may be tied in with the ignition system.

The LPG vapor withdrawal system uses the same components as the liquid withdrawal system except for the vaporizer coil which is not used because the vapor is withdrawn from the top of the supply tank, Figure 8-12B.

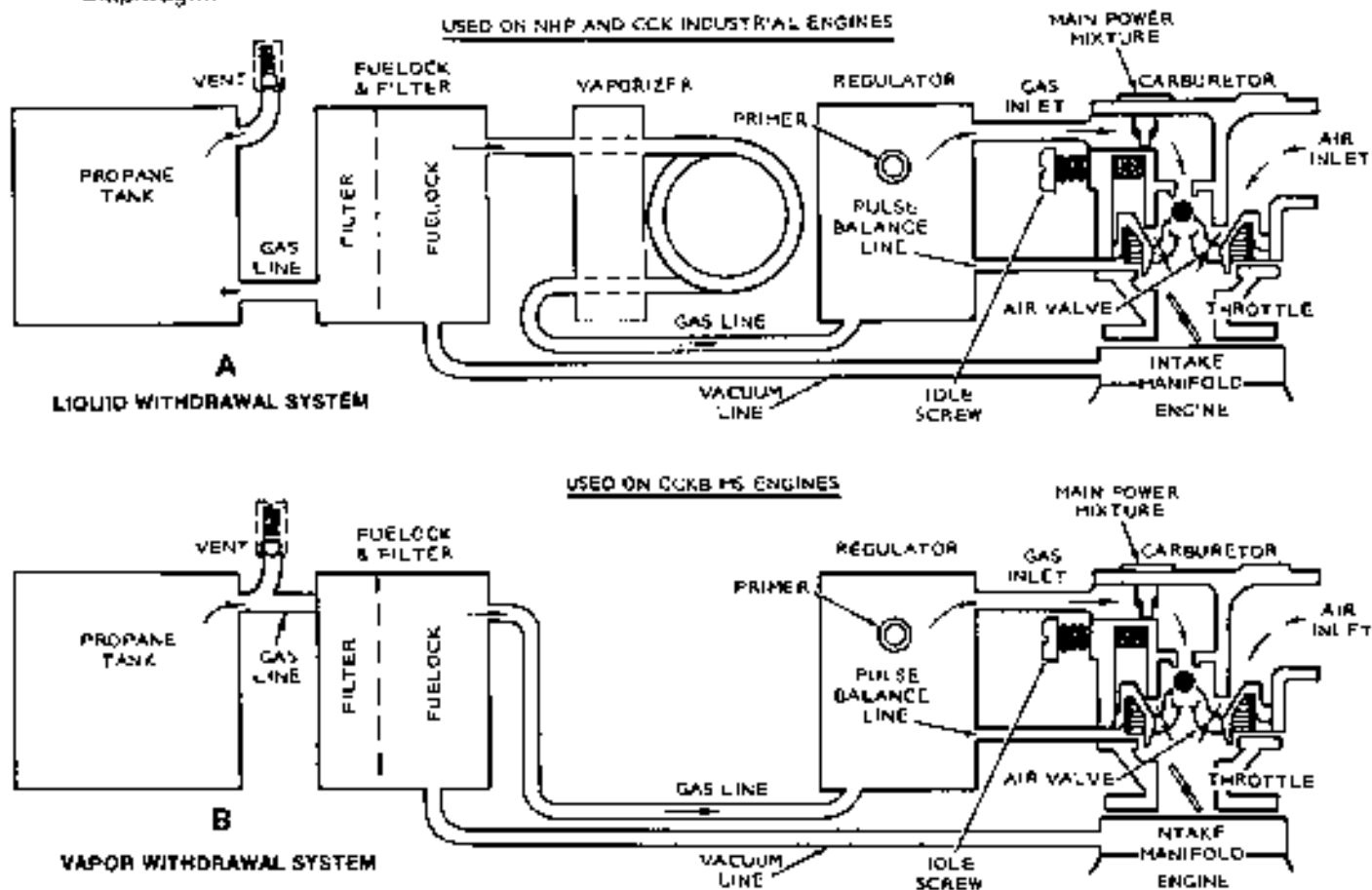

Rev 10-75

FUEL

The engine and carburetor operate on propane Liquefied Petroleum Gas—LPG. This discussion covers only systems and components used with propane liquid withdrawal applications.

Onan recommends that HD-5 Propane be used in Onan LPG engines.

FUELOCK AND FILTER

The IMPCO VFF30 is a vacuum operated fuelock and filter combined in one unit, Figure 8-13. It should be trouble-free and maintenance-free for extended periods. Normally, no adjustments or filter replacements are needed on a periodic basis, but repair kits and replacement filters are available for complete overhaul if a malfunction occurs. Each kit includes detailed and illustrated installation procedures and new replacement parts.



FIGURE 8-13. FUELOCK AND FILTER

The fuel inlet and outlet take 1/4-inch NPT fittings. The vacuum connection takes a 1/8-inch NPT fitting for a 7/32-inch I.D. hose. The fuelock opens with 2-inches water column at normal tank pressure.

The fuelock and filter unit replaces a separate line filter, an electric solenoid lockoff valve and a vacuum controlled switch required on earlier gas engine applications.

VAPORIZER COIL

The liquid propane vaporizer coil utilizes exhaust heat in its close wrap around either exhaust pipe. The vaporizer consists of a steel mounting bar and four coils of stainless steel tubing, Figure 8-14.

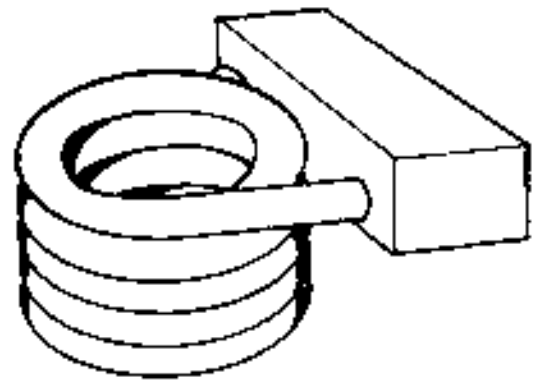

FIGURE 8-14. VAPORIZER COIL

REGULATOR

The IMPCO regulator is a two-stage regulator (LP Gas Converter) with a hand primer, Figure 8-15. It should be trouble and maintenance free for extended periods of operation. Repair kits are available for a complete overhaul if a malfunction occurs. The kit includes detailed and illustrated installation instructions. The secondary regulator lever assembly is subject to wear under heavy duty operation and may require replacement during an overhaul. The low pressure spring (blue) for vacuum control gives a negative 1-1/2-inch water column measurement on a manometer. The two vapor outlet ports and the LPG inlet have 1/2-inch pipe thread. The balance line connection is 1/8-inch pipe thread.

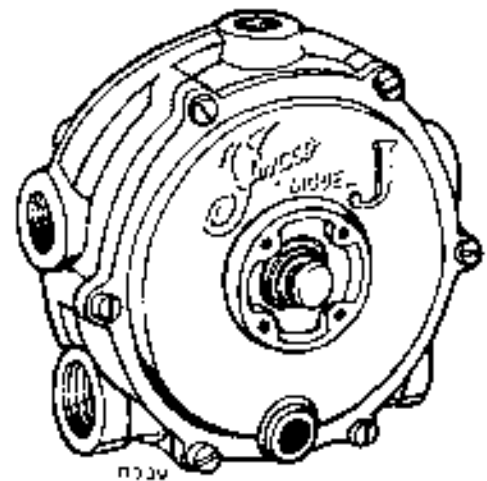

FIGURE 8-15. GAS REGULATOR

GAS CARBURETOR

The IMPCO carburetor or mixer (made special for Onan) employs a unique, moving venturi (air valve, metering valve and venturi combined) to measure airflow, to meter gas flow, and to mix the intake air and gas, Figure 8-16. The throttle controls engine speed and power in the same way as the carburetors on other gas or gasoline engines. An idle jet, a main jet (power mixture adjustment) and a throttle stop screw provide carburetor adjustments for maximum engine power and efficiency with low exhaust emissions.

Rev 10-75

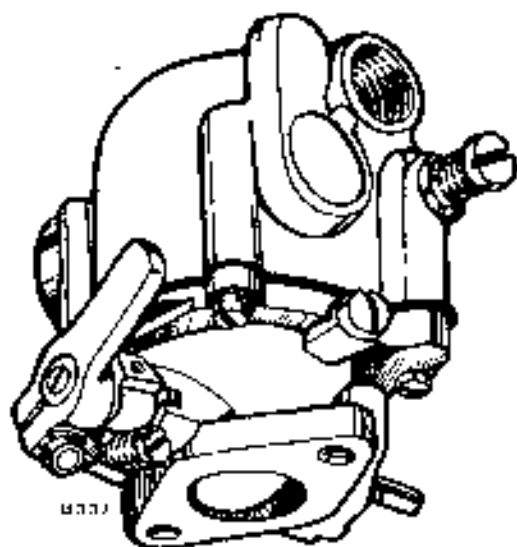

FIGURE 8-16. GAS CARBURETOR

CARBURETOR OPERATION

In operation, the moving venturi/air valve or air valve assembly opens in direct proportion to the breathing requirements of the engine to give optimum mixtures and good air/fuel distribution, Figure 8-17.

The air valve assembly operates in an up-and-down, piston-like motion inside the cylindrical cavity of the throttle body. When the engine is stopped, the air valve assembly is held in a closed position by a metering spring, Figure 8-17A. The gas passage in the throttle body is completely closed off by means of a synthetic rubber seat on the metering valve. When the engine is started, the air valve assembly moves downward off the gas passage inlet, allowing entry of gas into the venturi throat where it mixes with high-velocity intake air, Figure 8-17B. The higher the load demand, the greater the air and gas opening up to maximum throttle.

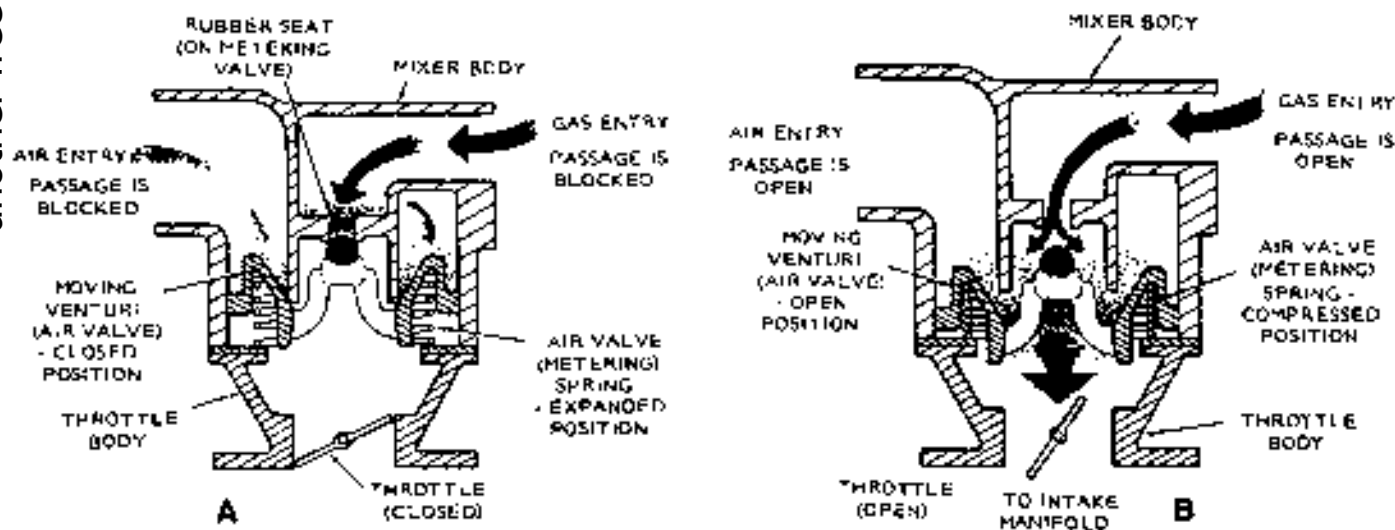
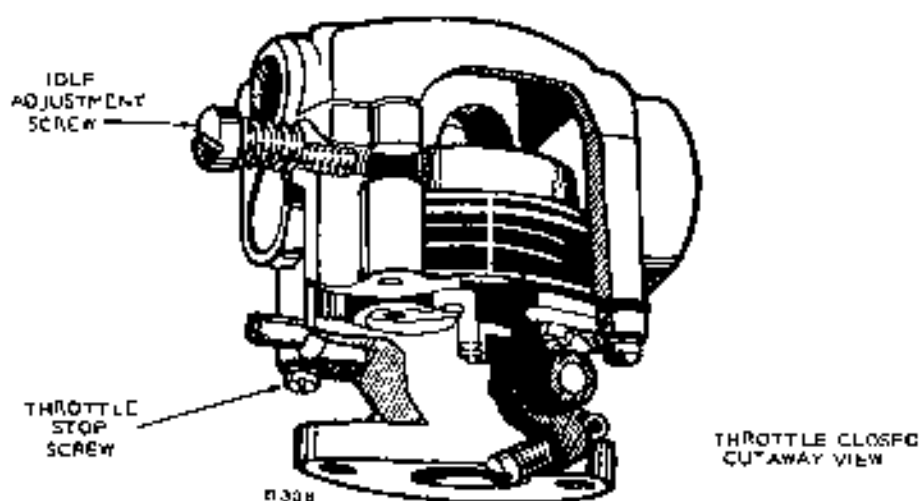

FIGURE 8-17. GAS CARBURETOR OPERATION

CARBURETOR ADJUSTMENTS

Gas engines with LPG carburetors maintain low exhaust emissions (Carbon Monoxide CO, Hydro Carbons HC, and oxides of Nitrogen NOx) as long as the carburetor is adjusted properly, the engine remains in good service condition, and high temperature, low ash crankcase oil is used.

INITIAL START ADJUSTMENTS (At factory or after service or maladjustment)

1. Set main power mixture to position shown in Figure 8-18.
2. Turn idle screw in fully clockwise.
3. Turn idle screw out 2-1/2 to 3-1/2 turns counter-clockwise.
4. Connect or turn on fuel supply to regulator.
5. Check (smell) for propane leaks.
6. Start engine—it should start within 20 seconds if fuel is available to carburetor.



FIGURE 8-18. INITIAL START ADJUSTMENT

CHECKING FOR FUEL AT CARBURETOR

WARNING Do not permit any flame, cigarette, or other igniter near the fuel system. Propane gas is highly flammable and potentially explosive in confined spaces. Use your sense of smell to detect leaks.

1. Disconnect fuel line at carburetor.
2. Momentarily, press primer button; you should smell gas at end of fuel line. If not, check fuel lines back to supply tank.

With experience, you should be able to feel gas pressure on the regulator diaphragm when you press the primer button.

3. Look for one or more shutoff devices.
4. On vacuum operated shutoff valve systems, close throttle (fully) to aid engine starting with better vacuum.
5. If fuel is present at carburetor, check ignition system or other engine malfunctions.

CARBURETOR ADJUSTMENTS WITHOUT EXHAUST ANALYZER

1. Run new engine at least ten hours at normal service load. Avoid high loads before proper adjustments are made.
2. Run engine at maximum throttle and normal load for ten minutes, or set main power mixture near mark between L and R as shown in Figure 8-18.
3. Set main power mixture as lean as possible without noticeable loss in power output. If frost develops and remains on regulator for more than five minutes, check for propane leaks and ensure that vaporizer coil wraps tightly around exhaust pipe.
4. If engine functions properly but frost remains on regulator, the carburetor power mixture is too rich. Adjust for maximum efficiency.
5. Recheck head bolt torque and valve lash after carburetor is adjusted.

IDLE SCREW AND IDLE STOP ADJUSTMENT

1. Run engine at idle speed (1200 rpm) for ten minutes.
2. Adjust idle screw for maximum speed, maximum speed should be attained when idle screw is turned fully clockwise into carburetor.
3. Set idle stop screw speed at 1350 rpm.
4. Turn idle screw out until engine speed slows to 1200 rpm.

CARBURETOR ADJUSTMENTS WITH EXHAUST ANALYZER

Exhaust analyzers (with at least ± 3 percent accuracy) should be infra-red equipment, but flame ionization can be used for measuring hydrocarbon emissions in parts per million n-hexane. All data is based on dry measurements which are obtained after removing all water vapor from the exhaust samples. A heat measurement will be about 15 percent less than for a dry measurement, if none of the water vapor is removed from the samples.

Main Power Adjustment:

1. Run engine at open throttle for normal maximum rpm for ten minutes or set main power mixture at mark between L and R as shown in Figure 8-18.
2. Adjust main jet for 1.0-plus 0.5-percent CO emission.
3. If frost develops and remains on regulator for more than five minutes, check for leaks and be sure vaporization coil wraps tightly around exhaust pipe.

When the fuel system functions properly, the regulator should be frost free after about five minutes running time.

Idle Screw Adjustment:

1. Run engine at 1200 rpm for ten minutes

- Using idle stop screw and idle mixture screw, set engine exhaust emissions for $.2 \pm .1$ percent CO at 1200 rpm on richest mixture possible.

If this condition is met, the CO emission will exceed .5 percent when idle screw is turned one half turn counterclockwise from setting attained in step 2.

- Return to 0.2 ± 0.1 percent CO idle screw setting.

At proper idle adjustment, the HC emission should be under 1000 ppm and CO₂ emission will be 8 to 10 percent

THROTTLE STOP ADJUSTMENT

- Adjust throttle stop clamp for maximum service load; throttle should be 20 degrees from vertical position at wide open throttle. Throttle travel from open to closed position should be 50 degrees.

CAUTION

Do not change the throttle stop to increase the throttle opening. Increasing the throttle opening beyond this point does not increase the power output of the engine because the carburetor is designed for even larger engines. It may, however, adversely affect governor operation.

- Check throttle linkage for freedom of movement.

SECTION 9. DIESEL FUEL SYSTEM

INDEX

DESCRIPTION	9-1
MAINTENANCE	9-1
Bleeding Fuel System	9-1
Beginning Spec S	9-1
Prior to Spec S	9-2
Water in Fuel Filters	9-2
Diesel Engine Compression Test	9-2
FUEL TANK AND LINES	9-2
FUEL TRANSFER PUMP	9-2
Testing	9-2
Transfer Pump Removal—Disassembly	9-3
Repair	9-3
Assembly	9-4
INJECTION PUMPS	9-4
PLB Injection Pump	9-4
Removal	9-4
Timing the PLB Pump	9-4
Depth Micrometer Method	9-5
Flowing the Pump	9-5
Maintenance	9-5
Installation	9-5
PSU Injection Pump	9-6
Repair	9-6
Removal	9-7
REPLACING AN INJECTION PUMP	9-7
Injection Pump Installation	9-7
Injection Pump Timing	9-8
Method 1, Calculation	9-8
Method 2, Flow Timing the Pump	9-8
NOZZLES	9-9
Inspection	9-9
Adjustment	9-10
Disassembly	9-10
Cleaning	9-10
Repair	9-10
Assembly	9-10
Installation	9-10

PREHEATING CIRCUIT	9-11
FUEL SOLENOID.....	9-11
TABLE 9-1. NOMINAL COMPRESSION PRESSURES	9-2
TABLE 9-2. SHIM THICKNESS	9-5
TABLE 9-3. PISTON DROP DATA.....	9-7
TABLE 9-4. INJECTION PUMP BUTTONS.....	9-8

DESCRIPTION

The diesel fuel system provides a means of filtering, transporting and delivering fuel in a fine spray to the engine cylinder at the correct time for ignition. The system consists of a primary fuel filter, fuel transfer pump, secondary fuel filter, injection pump and an injection nozzle. Figure 9-1 shows the fuel system beginning Spec S with dual filters. Only one filter was used prior to Spec S.

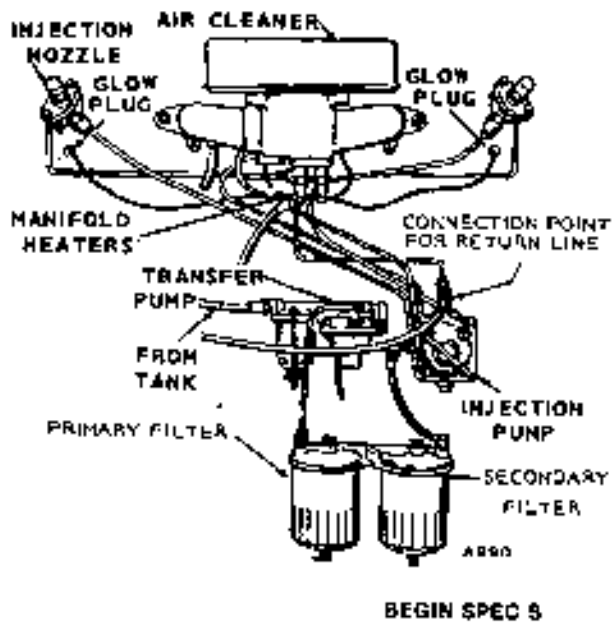
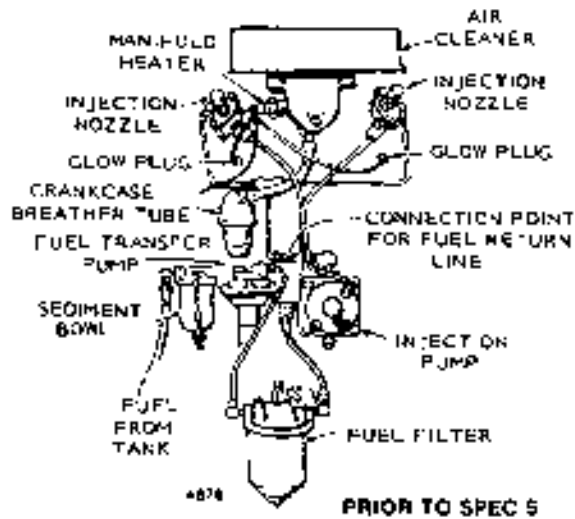

FIGURE 9-1. FUEL SYSTEM

The fuel transfer pump which operates directly off the engine camshaft, draws fuel from a supply tank and delivers it through two filters to the injection pump. The injection pump meters fuel and delivers it at high pressure to the injection nozzle at the correct time for ignition.

The injection nozzle opens at a set pressure, delivering fuel in a fine spray to the precombustion chamber for ignition.

Excess fuel is returned to the tank after each injection cycle by a fuel return line from the nozzle. An adapter combines the leak-off fuel with the flow-through fuel from the injection pump. A return line connected at this point returns the combined fuel back to the fuel supply tank.

CAUTION A diesel engine cannot tolerate dirt in the fuel system. It is one of the major causes of diesel engine failure. A tiny piece of dirt in the injection system may stop your unit. When opening any part of the fuel system beyond the secondary fuel filter, place all parts in a pan of clean diesel fuel as they are removed. Before installing new or used parts, flush them thoroughly, and install while still wet.

MAINTENANCE

In addition to the regular service periods (3000 hours), change the secondary fuel filter cartridge whenever the engine shows sign of starving from lack of fuel. Remove the secondary filter by removing the large cap screw in the center of the filter cover. Use care when replacing the filter cover.

BLEEDING FUEL SYSTEM

After replacing or cleaning the filters, bleed the fuel system of air.

Beginning Spec S: Starting with Spec S, the fuel filtration system has both primary and secondary fuel filters on a common mounting which is bolted to the oil fill tube. The engine cannot be run with either filter loose or missing, thus assuring proper filtration at all times.

Blood air from fuel system as follows: Disconnect the fuel return line. See Figure 9-2. Operate the hand priming lever on diaphragm type fuel transfer pump

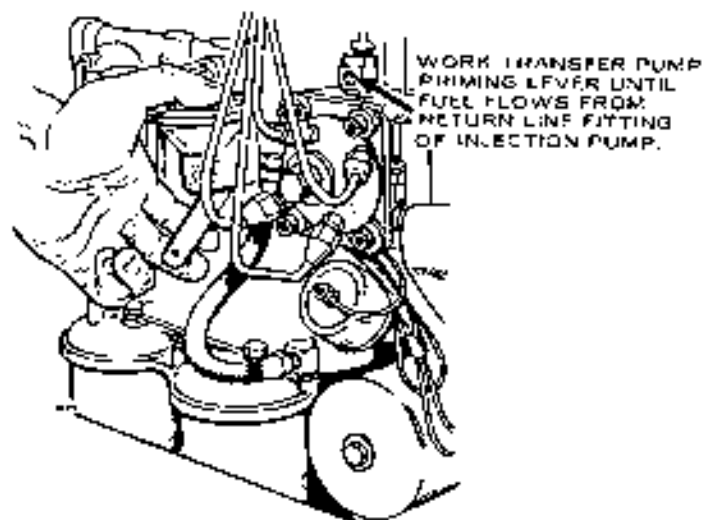

FIGURE 9-2. BLEEDING FUEL SYSTEM (BEGIN SPEC S)

Rev 10-75

until there are no air bubbles in fuel flowing from the fuel return line fitting. Then connect the fuel return line.

If the camshaft's pump lobe is up, crank engine one revolution to permit hand priming. When finished, return priming lever inward (disengaged position) to permit normal pump operation.

Prior to Spec S: Remove bleed plug from top of fuel filter on early models (prior to Spec S) Figure 9-2. Operate hand priming lever on transfer pump until all air bubbles clear fuel system. Reinstall bleed plug and return priming lever to inactive position.

Water in Fuel Filters: Drain water periodically as required from both filters. Replace primary filter every 600 hours and secondary filter every 3000 hours. When replacing filter, tighten screw until gaskets touch base, then tighten screw 1 to 1/2 turns.

Diesel Engine Compression Test

To ensure optimum performance, any internal combustion engine should have a certain nominal compression pressure and the compression should be relatively the same between cylinders. Acceptable variations are usually considered to be 15 to 20 psi between cylinders. The use of motor oil in cylinders to determine if low compression is due to piston rings or valves is not acceptable in diesel engines because they have very close clearances. Too much oil squirted in the cylinder may cause a hydrostatic lock damaging the piston, etc. Valve leakage in diesels can be detected by listening at the valve ports.

Table 9-1 shows nominal compression pressures for Onan diesel engines. There may be variations due to temperature, atmospheric conditions and altitude. These pressures are for a warm engine at cranking speed (about 300 rpm).

If there is a large variation between the cylinders at cranking speed, a compression test may be taken with the engine running at governed speed. Follow the instructions for the engine compression tester being used.

Perform compression check with the Onan compression tester listed in the *Tool Catalog* portion of this manual.

FUEL TANK AND LINES

Where a separate fuel tank is used, install so the vertical distance from bottom of the tank to the fuel pump does not exceed six feet. Auxiliary fuel pumps are available to provide an additional eight-foot lift.

Avoid gravity feed of fuel to the engine. Provide a siphon break if tank is above pump. When sharing a fuel tank, do not connect to an existing line at a point above the fuel supply level.

These diesel engines require a fuel supply line and a separate return line. Install the fuel supply line from tank to the 1/8-inch pipe inlet in the fuel pump. Connect fuel return line to fitting at injection pump. See Figure 9-2. Use approved flexible fuel lines at the engine to absorb vibration. Be sure there are no air leaks in the suction line.

Install a shut-off valve in the tank for service convenience.

FUEL TRANSFER PUMP

The transfer pump is located on the left side of the engine near the rear. If fuel does not reach the secondary filter, make the following checks before removing the pump.

1. Check fuel tank and see that shutoff valve is open.
2. Remove fuel line from transfer pump outlet and work priming lever on the pump. Fuel should spurt out of pump. If not, remove pump for repair or replacement.

Testing: If the transfer pump delivers fuel, test it with a pressure gauge or manometer. Perform these tests before removing the pump from the engine. Remove the pump outlet and install the pressure gauge, Figure 9-3.

TABLE 9-1. NOMINAL COMPRESSION PRESSURES

MODEL	SPEC LETTER	NOMINAL COMPRESSION PRESSURE*
RDJF, MDJE, MDJF	All	350-400 psi
DJA, DJB, DJC, RDJC, JDJA, JDJB, MDJC	A to N	300-350 psi
DJA, DJB, DJC, MDJA, MDJB, MDJC, RDJC	Begin Spec P	350-400 psi

* - Approximately 300 rpm.

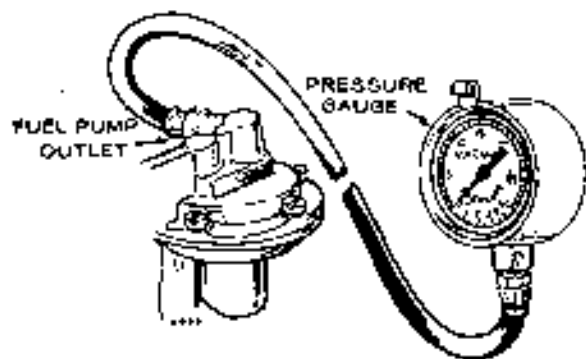

FIGURE 9-3. FUEL PRESSURE GAUGE

Test the valves and diaphragm by operating the primer lever a few times and watching the pressure. It should not drop off rapidly after priming has stopped.

Run the engine at governed speed on fuel provided by gravity feed and measure the fuel pressure developed. Pressure should be between 12 and 14 psi (82.8 and 96.6 kPa) with the gauge 16 inches (406.4 mm) above the fuel pump.

A low pressure reading indicates extreme wear in one part or some wear in all parts, and the pump should be overhauled or replaced. If the reading is above maximum, the diaphragm is probably too tight or the diaphragm spring too strong. This can also be caused by fuel seeping under the diaphragm retainer nut and between the diaphragm layers, causing a bulge in the diaphragm. Overhaul the pump and replace the defective parts.

Low pressure with little or no pressure leak after pumping stops indicates a weak or broken spring or worn linkage, and, in most cases, the pump should be replaced. Figure 9-4 shows the fuel transfer pump.

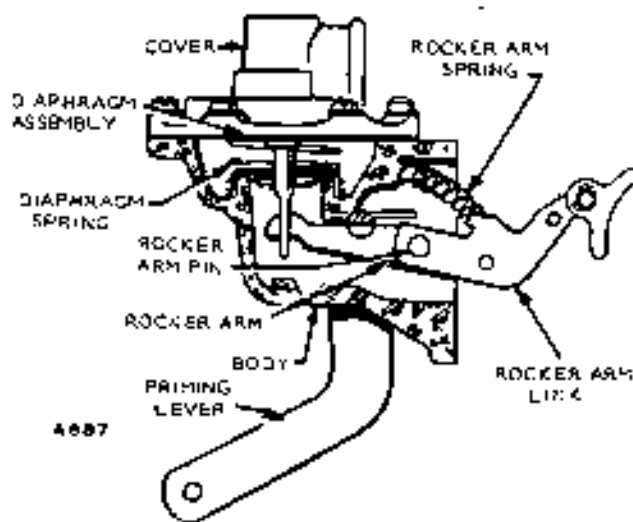
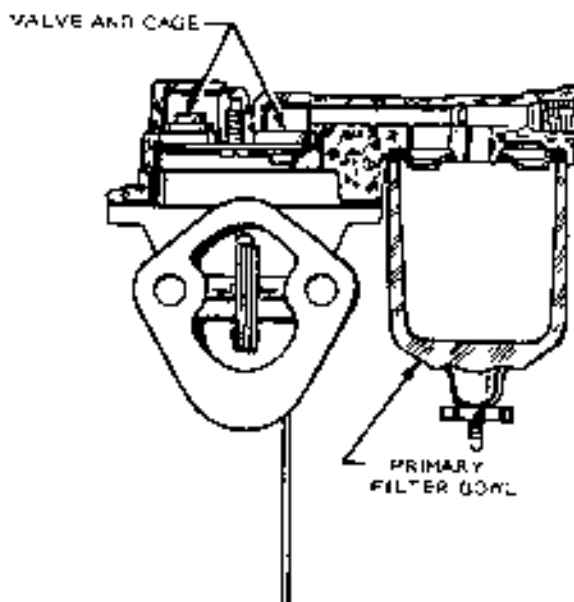

FIGURE 9-4. FUEL TRANSFER PUMP

Transfer Pump Removal—Disassembly

1. Remove pump inlet and outlet lines. Remove two cap screws holding pump to engine and lift it off.
2. Notch the pump cover and body with a file so they can be reassembled in same relative positions and remove six screws holding them together.
3. Tap body with a screwdriver to separate two parts. Do not pry them apart; this would damage diaphragm.
4. Remove screws holding valve plate to cover and lift out valve and cage assemblies.
5. Drive out rocker arm hinge pin.
6. Remove rocker arm, spring and link.
7. Lift out diaphragm assembly and diaphragm spring.

Repair: Transfer pump failure is usually due to a leaking diaphragm, valve or valve gasket. A kit is available for replacement of these parts. Because the extent of wear cannot be detected by the eye, replace all parts in the kit. If the diaphragm is broken, or leaks, check for diluted crankcase oil and replace.

Occasionally, failure is due to a broken or weak spring or wear in the linkage. In this case, replace the worn parts or install a new pump. Obtain replacement parts other than the repair kit from an original equipment parts distributor.

Assembly

1. When installing a new diaphragm, soak it in fuel before assembling. Insert diaphragm spring and soaked diaphragm into pump body.
2. Insert link and rocker arm into body and hook it over diaphragm pull rod. Align rocker arm with rocker arm pin hole and drive in pin. The priming lever must be in position shown in Figure 9-4 when installing rocker arm.
3. Compress rocker spring and install between the body and rocker arm.
4. Insert valve cages, gaskets and valve cover plate. Position inlet valve with spring showing and outlet valve with spring in cover recess.
5. Assemble cover to body with notch marks lined up. Install screws, but do not tighten.
6. Push rocker arm in full stroke and hold in this position to flex diaphragm.

The diaphragm must be flexed, or it will deliver too much fuel pressure.

7. Tighten cover screws alternately and securely, then release rocker arm.
8. Install pump on the engine and repeat pressure test.

INJECTION PUMPS

Onan J series engines use one of two possible injection pumps. The DJA engines use a model PLB American Bosch injection pump. The DJB and DJC engines use a model PSU American Bosch pump.

PLB Injection Pump

Figure 9-5 illustrates a cross section of the PLB injection pump. When the piston nears the end of the compression stroke, the plunger has been moved upward by the camshaft lobe thus closing the ports, trapping fuel, and forcing the delivery valve off its

seat. The fuel flow is up past the delivery valve and spring to the high pressure line leading to the injection nozzle. Injection continues until the helix on the plunger passes through the sleeve and fuel spills which drops the pressure rapidly. Delivery valve action aids in dropping line pressure and keeps fuel from draining out of the line. This forms a void between the injection pump and nozzle keeping the nozzle from opening on the next firing cycle.

The amount of fuel delivered is controlled by rotating the plunger, thus changing the length of its effective pumping stroke. The distance the plunger travels is always the same because the cam lift never varies.

Timing the pump to the engine determines the port closing point—the correct point is 17°BTC (before top center). The control sleeve position controls port opening and is, in turn, controlled by the throttle setting.

Removal

Remove the pump inlet and outlet lines. Remove the two cap screws holding the pump to the engine and lift it off. Don't lose the shims—they time the injection pump to the engine. Cap all openings in the pump and fuel lines to keep dirt out of the fuel system.

Timing the PLB Pump

Pump timing procedures determine the correct thickness of shims between pump and engine so port closing occurs at the proper time.

The most accurate method of injection pump timing is with a depth micrometer, Figure 9-6. However, if a depth micrometer isn't available, time it by *Flowing the Pump*.

Injection pump must be timed on the compression stroke, not the exhaust stroke.

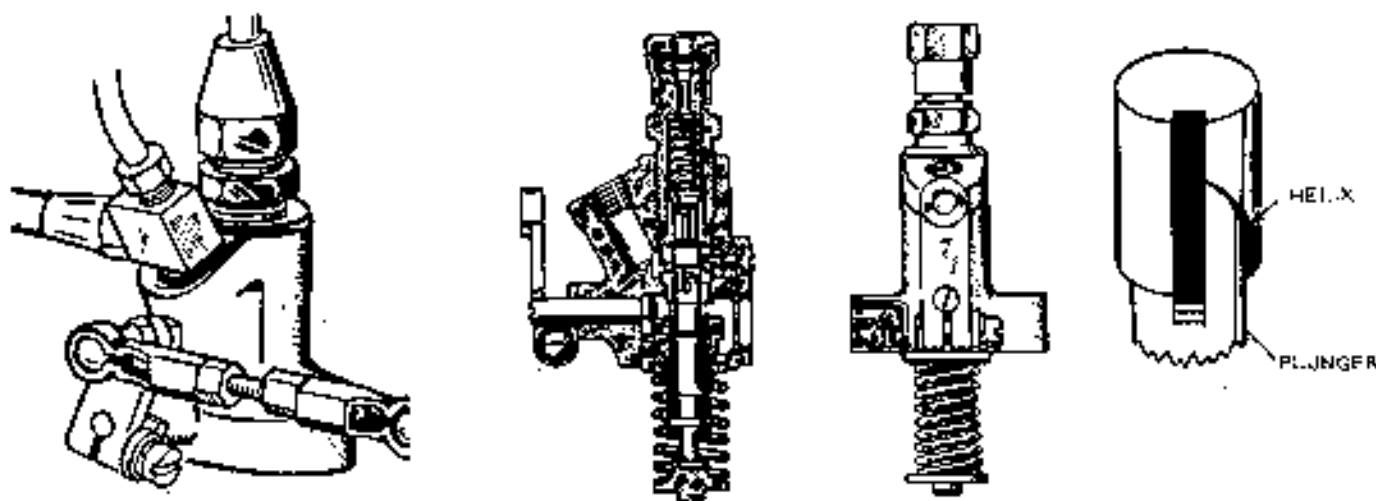

FIGURE 9-5. PLB INJECTION PUMP (DJA)

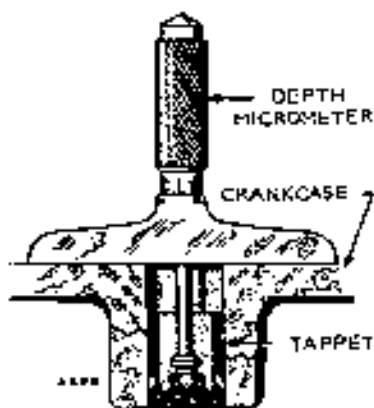

FIGURE 9-6. MEASURING WITH DEPTH MICROMETER

Depth Micrometer Method

1. Install pump tappet in its recess and position flywheel port closing mark (PC) at timing pointer on compression stroke.
2. Using a depth micrometer, measure distance from pump mounting pad on crankcase to tappet center, Figure 9-6.
3. Subtract the depth obtained in Step 2 from port closing dimension of pump (1.670-inch [42.4 mm]). The result is shim thickness necessary to correctly time pump.

Shim's thickness may vary from .005-inch to .052-inch (0.15 to 1.32 mm). If it does not fall within these limits, check camshaft and tappet for excess wear or improper assembly.

4. Select correct shims for required thickness.
5. Install pump.

Flowing the Pump

1. Install pump with .005-inch (0.15 mm) shims between pump and pad.
2. Loosen delivery valve holder to relieve pressure on spring, Figure 9-7.
3. Rotate flywheel to about 15 degrees before port closing (PC) point. Operate transfer pump hand primer lever and rotate flywheel slowly clockwise until all fuel stops coming out of pump outlet. This is port closing point.
4. Measure distance from point where port closing occurs to PC mark on flywheel using scale marked in tenths of an inch. Find thickness of shims to be added from Table 9-2.
5. Install pump.

Maintenance

Most fuel system troubles are not due to a faulty injection pump. Test the rest of the fuel system before condemning the injection pump.

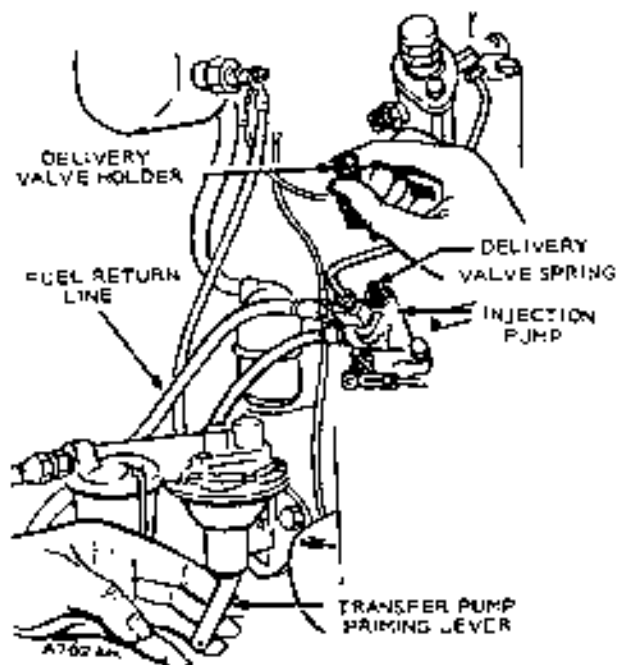

FIGURE 9-7. DELIVERY VALVE HOLDER AND SPRING

TABLE 9-2. SHIM THICKNESS

DISTANCE MEASURED STEP 4 (In.)	ADD THESE SHIMS	DISTANCE MEASURED STEP 4 (In.)	ADD THESE SHIMS
1	.010	1.7	.034
2	.014	.8	.038
.3	.018	.9	.042
.4	.022	1.0	.046
.5	.026	1.1	.050
.6	.030	—	—

Installation

Prior to mounting the injection pump to the cylinder block, follow steps 1 through 3.

1. Slide shim or shims (using proper thickness of shims for correct timing) over pilot until they are flat on pump flange, Figure 9-8.

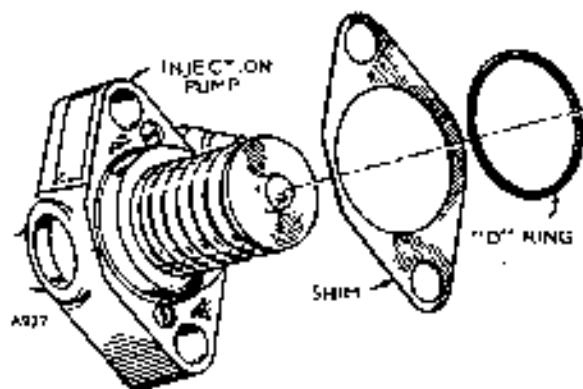

FIGURE 9-8. INSTALLING SHIMS

2. Dip seal ("O" ring) in engine lubricating oil.
3. Slide seal over pilot until tight against shim or shims.
4. With shims and seal in place, insert pump into cylinder block mounting pad and insert mounting screws.
5. Torque mounting screws (tighten alternately) to 18-21 ft. lbs. (24.4 to 28.5 N•m).
6. Install fuel inlet line and governor linkage.
7. Bleed pump and then install fuel outlet line.

PSU INJECTION PUMP

The American Bosch PSU injection pump is located near the center of the left side of the engine crankcase. A cam and gear on the camshaft drive the pump. The gear drives the pump face gear, providing fuel distribution to each cylinder in the proper order. The cam operates the pump plunger, producing pressure to deliver the fuel and open the nozzles. A control sleeve meters the fuel by controlling the length of time the plunger port is closed, maintaining pressure and the amount of fuel delivered in each stroke. Timing the pump to the engine determines the point of port closing. The port closing point is 19 degrees before top center (BTC) on all models beginning Spec P. The port closing point for models prior to Spec P is 21 degrees BTC. The position of the metering sleeve on the plunger controls the port opening and this depends on the governor setting.

Figure 9-9 illustrates the injection pump cross section. PSU models are single plunger, constant stroke, distribution type pumps. Fuel from the transfer pump enters the tapped hole (A) and flows into the fuel sump and through drilled passages to the fill cavity (B) directly above the plunger. As the plunger moves upward from camshaft action, the fill port (C) is sealed (this is the port closing point). As the plunger continues its upward stroke, the fuel which is forced through the delivery valve is conveyed through the drilled passage (D). At this time, this passage is in line with the annulus (E). A slot above the annulus on the plunger indexes with a drilled passage to the appropriate fuel outlet.

Injection continues until the spill port (F) rises above the fuel metering control sleeve (G). Duration of fuel injection is controlled by the position of the fuel metering control sleeve. Maximum fuel delivery occurs when this sleeve is in its uppermost position. Fuel flow stops (no delivery to nozzles) when the sleeve is at its lowest position. At this point the spill port is exposed and no pressure is developed. The dashed line on the plunger extending from the spill port to the top represents a drilled passage.

Figure 9-10 shows how the pump mounts on the engine block and meshes with the camshaft drive gear.

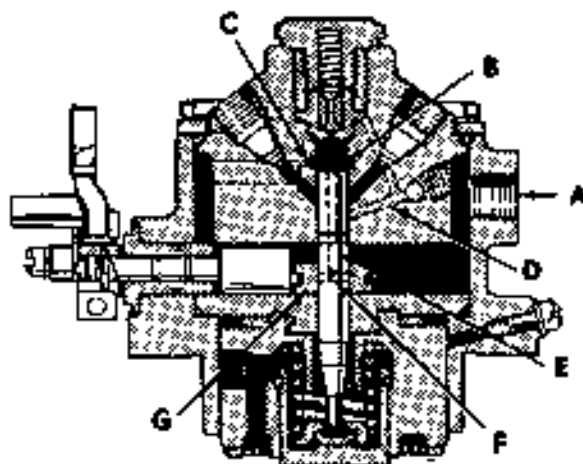

FIGURE 9-9. PSU INJECTION PUMP (DJB-DJC)

Repair: Most fuel system troubles are not due to a faulty injection pump; test the rest of the fuel system before condemning the injection pump.

Onan discourages field repair of the injection pump because of the exceptionally close tolerances between parts and the specialized equipment necessary for repair. The injection pump is an expensive part of the unit and even a particle of dirt as fine as talcum powder could score its working surfaces. If the rest of the fuel system is in working order and fuel delivery abnormal, remove the pump for replacement or repair. American Bosch maintains a world-wide repair service for these pumps.

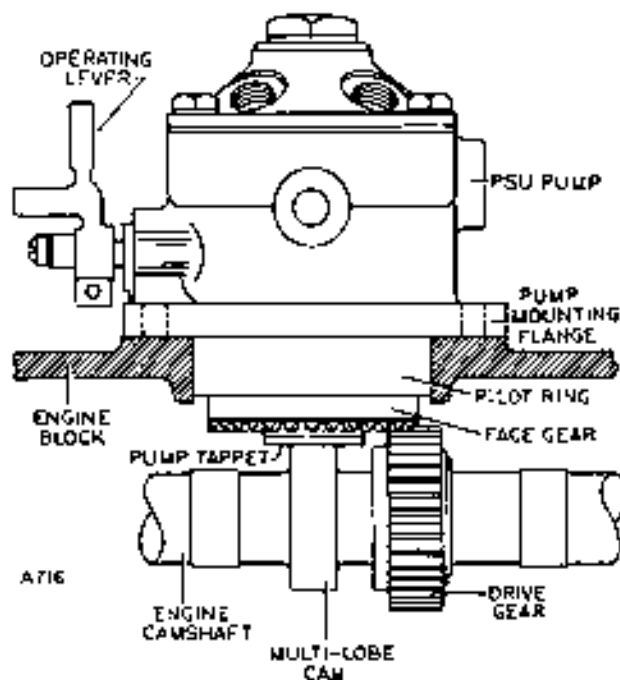

FIGURE 9-10. INJECTION PUMP IN RELATION TO ENGINE CAMSHAFT

Rev 10-75

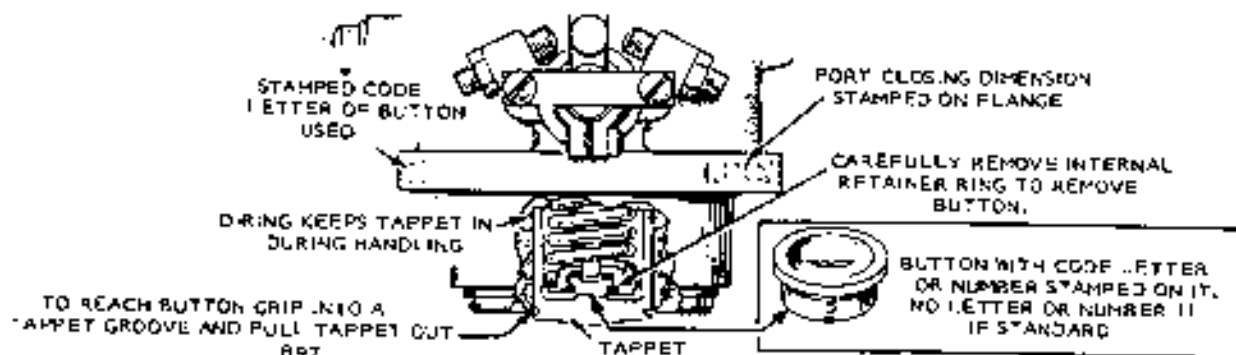

FIGURE 9-11. INJECTION PUMP BUTTON INSTALLATION

Removal: Remove the pump inlet, outlet, and return lines. Remove the four cap screws holding the pump to the crankcase and lift it off. Be careful to retain the shims between the crankcase and pump. The correct thickness of shims, as stamped on the crankcase, is important to proper pump operation; it provides the proper gear lash.

When removing the pump for replacement, record the button thickness and port closing dimensions stamped on the side of the pump mounting flange. Figure 9-11. These values are important in timing the new pump to the engine.

REPLACING AN INJECTION PUMP

Pump timing is critical. The injection pump on each engine must be timed to that particular engine by using a timing button of specific thickness. Each new pump has its own port closing dimension stamped on it. Use method 1 or 2 to determine the correct new button thickness.

CAUTION Do not change the pump mounting shims' total thickness. They are the correct thickness for proper pump gear to camshaft gear mesh.

The port closing (PC) mark is not stamped on replacement flywheels. Therefore, the PC mark must be established by measuring the piston drop with the cylinder head removed prior to injection pump timing. Since injection occurs at the port closing position, the PC mark can only be located by comparing the old flywheel with the new one, or by measuring the piston drop from its top center position on the compression stroke of number one cylinder. Piston drop data for DJA, DJB, and DJC engines is given in Table 9-3.

TABLE 9-3. PISTON DROP DATA

PISTON DROP		ENGINE	PORT CLOSING
Inches	mm		
0.102	2.59	All DJA	17 degrees
0.128	3.25	DJB & DJC (Begin Spec P)	19 degrees
0.155	3.94	DJB & DJC (Prior to Spec P)	21 degrees

Injection Pump Installation

1. Put No. 1 cylinder on compression stroke.
2. Turn flywheel to port closing mark (PC) on front cylinder compression stroke.
3. Remove timing hole screw located on pump mounting flange. Insert a 1/8-inch (3.175 mm) diameter wire into hole, Figure 9-12.

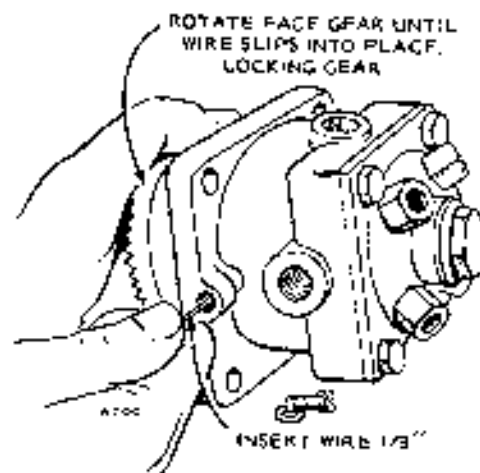

FIGURE 9-12. INJECTION PUMP

4. Rotate pump face gear until wire slips into place, locking gear in position.
5. Mount pump on crankcase (be sure shims are in place) and secure with screws. If "O" ring between pump and crankcase is worn, cracked or otherwise defective, replace it.
6. Remove 1/8-inch (3.175 mm) wire.
7. If pump was not timed, do it now, using Method 2.
8. Connect flexible fuel inlet line to pump inlet. Connect fuel return line.
9. Connect each fuel outlet line to proper pump outlet.
10. Connect linkage to governor.
11. Run engine and adjust governor maximum stop

Injection Pump Timing

Time the injection pump to the engine by using the proper thickness timing button between the pump plunger and tappet. It was timed to the engine when installed at the factory so the port closing for injection occurs at 19° BTC (21° BTC prior to Spec P). See Figure 9-13.

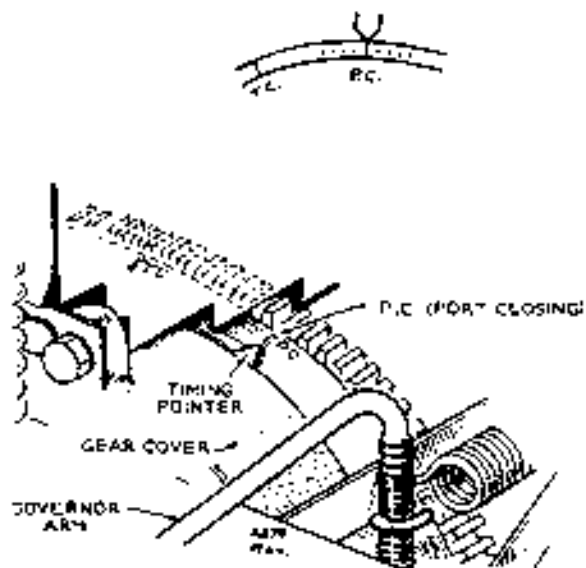

FIGURE 9-13. INJECTION PUMP TIMING

Use *Method 1* when replacing an old pump; if the port closing dimensions and button number of the old pump were recorded. Use *Method 2* if the dimensions are lost, and old pump is being retimed, or when replacing either the camshaft or crankshaft.

Remember, pump timing is critical.

Method 1, Calculation

This is a means for calculating the correct button thickness before the pump is installed. It requires the port closing dimensions and button thickness from the pump being replaced. Put the dimensions in the formula below and calculate the new button thickness. Determine the button code letter from Table 9-4.

Example

Part closing dimension of old pump	1.109
Button thickness of old pump	<u>-0.107</u>
	1.216
Port closing dimension of new pump	<u>-1.094</u>
Button thickness of new pump	0.122

Use button M or 12

Install the correct button in the pump (Figure 9-11) and install the pump following the instructions under *Injection Pump Installation*.

Method 2, Flow Timing the Pump

1. Install a standard timing button (not marked) in pump and install pump on engine steps 1 through 5 under *Injection Pump Installation*.
2. Remove delivery valve cap screw (Figure 9-14) and lift out delivery valve spring and delivery valve.
3. Rotate flywheel counterclockwise to about 15 degrees before port closing mark (PC). The pointer to indicate timing marks is located on the gear cover near the governor arm. Use a socket wrench on the flywheel cap screw to rotate the flywheel.

TABLE 9-4. INJECTION PUMP BUTTONS

GROUP 1			GROUP 2			GROUP 3		
CODE	PART NO.	SIZE	CODE	PART NO.	SIZE	CODE	PART NO.	SIZE
16 or S	147-0186	0.134	1 or A	147-0147	0.119	6 or F	147-0152	0.101
15 or R	147-0187	0.131	2 or B	147-0148	0.116	7 or H	147-0153	0.098
14 or P	147-0188	0.128	3 or C	147-0149	0.113	8 or J	147-0154	0.095
13 or N	147-0189	0.125	4 or D	147-0150	0.110	9 or K	147-0155	0.092
12 or M	147-0190	0.122*	5 or E	147-0151	0.107	10 or L	147-0156	0.089
			11 or Std.	147-0161	0.104			

* - Button 12 or M is in the mid-range of button sizes.

LATE MODELS

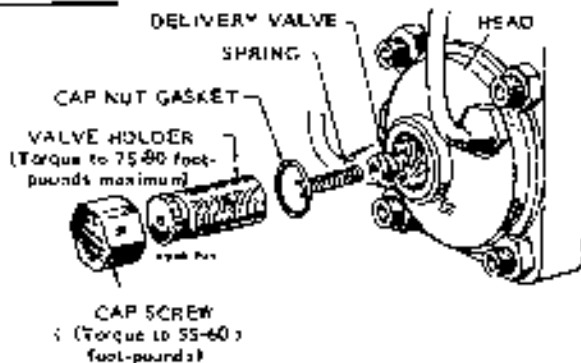

FIGURE 9-14. DELIVERY CAP AND VALVE SCREW

- Set throttle lever on pump to wide open position (compress stop solenoid plunger spring or remove stop solenoid assembly). Connect fuel line from pump to number 1 cylinder so that outlet is above the level of the injection pump (otherwise fuel will run out by gravity and give an inaccurate port closing). Connect lines from fuel supply to transfer pump, transfer pump to filter, filter to injection pump. Operate fuel transfer pump primer lever to obtain fuel pressure and very slowly rotate flywheel clockwise (from front of engine). Fuel will stop flowing from the end of the injection line on number 1 cylinder at the port closing point. Be sure you still have fuel pressure at the PC point. Check pressure by working primer lever at port closing; no fuel should flow from injection line.
- Check timing pointer. It will be within 0.5-inch (12.7 mm) on either side of port closing mark on flywheel. If timing pointer and port closing mark coincide, button thickness is correct. If not, measure distance from mark to point on flywheel below the pointer and determine proper button from Table 9-4.
- Remove pump and insert proper timing button, Figure 9-11.
- Repeat pump installation, steps 1 through 5 under *Injection Pump Installation*.
- Check port closing by repeating steps 1 through 3. Pointer should indicate port closing mark.
- Replace delivery valve disassembly. Torque valve to 75-80 ft. lbs. (102 to 108 N•m).
- Finish installation procedure.

NOZZLES

The American Bosch injection nozzles are the conventional inward-opening pintle type with adjustable opening pressure, Figure 9-15. They are factory adjusted to open at 1900 to 1950 psi (13.110 to 13.455 kPa). However, after several hundred hours of operation the nozzle pressure will decrease to approximately 1750 psi (12.075 kPa).

New nozzles are adjusted at 1800 psi (13.110 kPa). Nozzles used more than 10 to 15 hours are adjusted at 1750 to 1800 psi (12.075 to 12.420 kPa).

CAUTION Do not attempt to disassemble the nozzles or adjust nozzle pressure without the proper test equipment. A nozzle pressure tester is essential to do this work.

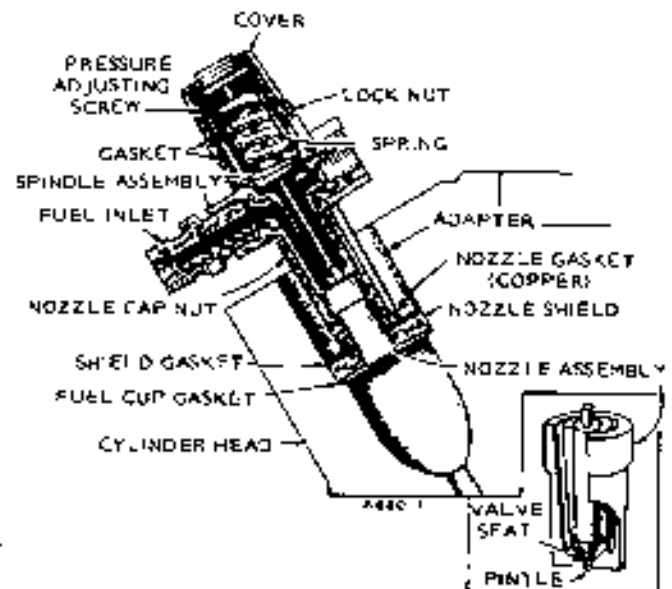

FIGURE 9-15. NOZZLE ASSEMBLY

Inspection: To inspect the nozzle spray pattern remove the nozzle from the cylinder head. Crank the engine, let the nozzle spray into the air and watch the pattern. The spray should be cone shaped with a solid appearing center surrounded by cloudlike fog in which the spray is evenly atomized. An apparent chattering of the nozzle is normal. See Figure 9-16.

If streamers are visible, the pattern is badly distorted or the nozzle drips before it reaches opening pressure, it is defective and must be cleaned or replaced.

WARNING Do not let the nozzle spray against your skin. The fuel can penetrate flesh and cause a serious infection.



FIGURE 9-16. NOZZLE SPRAY PATTERN

Rev 10-75

Adjustment: To adjust the opening pressure, remove each nozzle from the engine and remove the cap nut over the adjusting screw of each. Install the nozzle to be tested on a static fuel nozzle testing fixture (may be purchased from Onan). Following the instructions on the tester, adjust the opening pressure to 1750 psi (12.075 kPa) by turning the adjusting screw. Clockwise increases the pressure and counterclockwise decreases it. Do not try to adjust the pressure without a testing fixture.

Disassembly: When removing and disassembling nozzles, separate and label all components of each nozzle. Never interchange components between nozzles.

1. Remove each nozzle assembly from engine and remove fuel inlet and return lines.
2. Clamp nozzle holder body in a vise and remove nozzle cap nut and nozzle.
3. Install nozzle cap nut loosely to protect lapped surface for the holder body.
4. If necessary to further disassemble nozzle, reverse pressure adjusting screw and lift out spring and spindle assembly.

Cleaning: Work only in a clean room, on a clean work bench. Keep a pan of diesel fuel handy and a supply of clean, lint-free wiping rags.

Onan offers a kit to aid nozzle cleaning. See SPECIAL TOOLS section.

Never use hard or sharp tools, emery paper, grinding powder or abrasives of any kind.

Soak each nozzle in fuel to loosen dirt. Then clean the inside with a small strip of wood soaked in oil and the spray hole with a wood splinter. If necessary, clean the outer surfaces of the nozzle body with a brass brush but do not attempt to scrape carbon from the nozzle surfaces. This can severely damage the spray hole. Use a soft oilsoaked rag or mutton tallow and felt to clean the nozzle valve.

Repair: If cleaning will not eliminate a nozzle defect, replace the nozzle or take it to an authorized American Bosch service station. Do not attempt to replace parts of the nozzle except for nozzle and pintle assembly.

Assembly: Rinse both valve and nozzle thoroughly before assembly and coat with oil. The valve must be free in the nozzle. Lift it about 1/3 of the way out of the body. It should slide back to its seat without aid when the assembly is held at a 45 degree angle. If necessary, work the valve into its body with clean mutton tallow.

1. Remove all pressure on nozzle spring by adjusting pressure adjusting screw.
2. Clamp nozzle holder body in a vise.
3. Set valve in body and set nozzle over it.
4. Install nozzle cap nut loosely.
5. Place centering sleeve over nozzle (Figure 9-17) for initial tightening and then remove centering sleeve to prevent it from binding between nozzle and cap nut.
6. Tighten nozzle cap nut to specified torque.

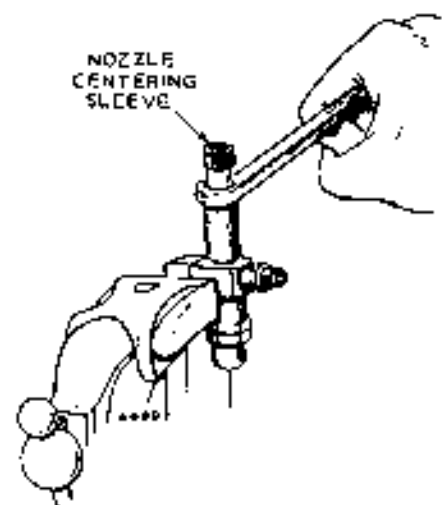

FIGURE 9-17. TIGHTEN NOZZLE

Installation: Before installing the injection nozzles in the engine, thoroughly clean each mounting recess.

A dirty mounting surface could permit blow-by, causing nozzle failure and a resulting power loss.

1. Install a new heat shield to head gasket in cylinder head recess.
2. Install heat shield, a new nozzle gasket and nozzle adapter.
3. Insert nozzle assembly into recess. Do not stroke tip against any hard surface.
4. Install nozzle flange and two cap screws. Tighten cap screws alternately to avoid cocking nozzle assembly. Tighten each to 20-21 ft. lb. (27-28 N•m).

PREHEATING CIRCUIT

This circuit consists of a manifold heater (two used on DJC) to heat the engine intake air in the intake manifold and glow plugs in each cylinder to heat the pre-combustion chamber. Used for engine starting, the manifold heater and glow plugs are wired in parallel and controlled by a preheat switch, Figure 9-18.

Check each heater by removing its lead, operating the preheat switch, and touching the lead to its terminal. If it sparks, there is continuity and the heater is working. If any components of this circuit fail, replace them. Do not attempt repairs on individual components. If there is still a question, check the component for heating.

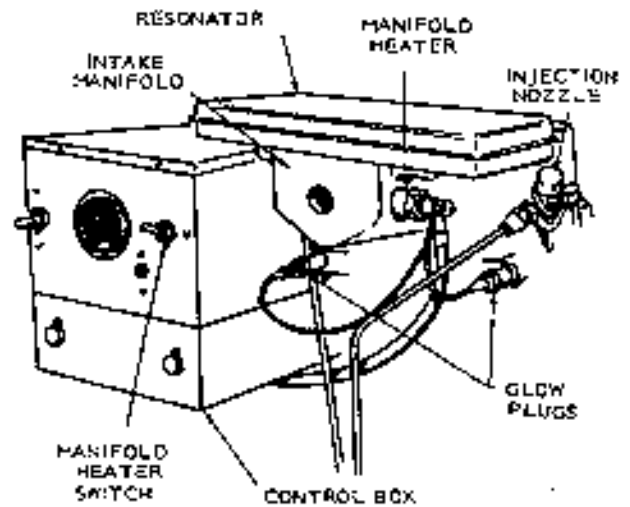

FIGURE 9-18. PREHEATING SYSTEM

FUEL SOLENOID

This solenoid is also referred to as a governor solenoid as it over-rides the governor, Figure 9-19. The solenoid is mounted on the cylinder air housing bottom pan and controls the injection pump operating lever. When energized, the plunger is in the solenoid body. When de-energized, the solenoid spring forces the plunger against the operating arm to shut off fuel. The solenoid has two coils. Both are energized for pulling the plunger up. When the plunger reaches top, it opens a set of contacts, de-energizing the pull-in coil. The other coil holds the plunger up.

To test the solenoid, check plunger operation and current draw with 12-volt input. Current draw with the plunger up should be about 1 amp. If it is much greater, the contacts did not open.

The solenoid plunger should be adjusted so it fully stops injection when in the de-energized position. To adjust the plunger length, screw the hex head cap screw and jam nut on the plunger bottom in or out. If the plunger sticks, remove the solenoid from its mounting plate and clean the plunger and recess in the solenoid.

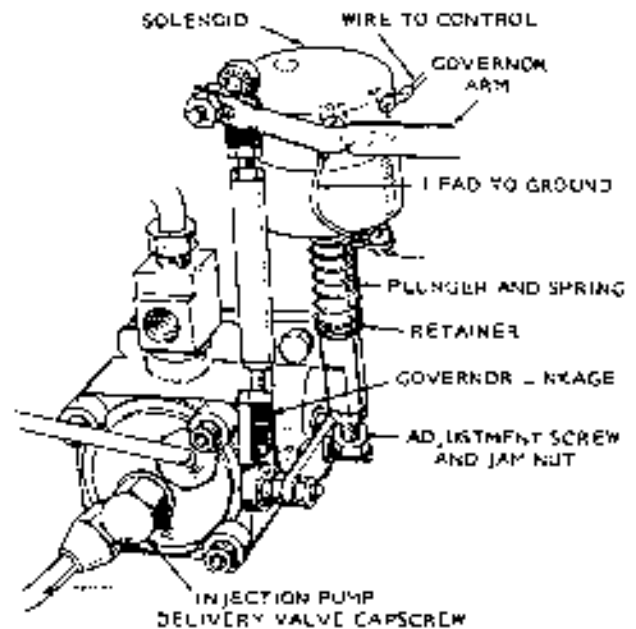

FIGURE 9-19. FUEL (GOVERNOR) SOLENOID

SECTION 10

IGNITION AND BATTERY CHARGING SYSTEMS

INDEX

Ignition System Description	10-2
Ignition System Components	10-2
Magnetos	10-2
Wiring	10-3
Ignition Coils	10-4
Ignition Coil Tests	10-4
General Instructions for Testing a Coil	10-5
Using an Ohmmeter to Test Coils	10-5
Breaker Points	10-6
Breaker Point Gapping	10-6
Testing Ignition Components	10-6
Battery Care	10-7
Battery Handling Safety—Warnings	10-8
Spark Plug Maintenance	10-8
Spark Plugs	10-8
AK, AJ, LK ENGINE SERIES	10-9
Magneto Ignition	10-9
Timing	10-11
ANTI-FLICKER MECHANISM	10-11
2.7 AJ Engines	10-12
CCK, CCKA, CCKB AND RCCK ENGINE SERIES	10-13
General	10-13
Engines Without Spark Advance Mechanism	10-13
Timing CCK Series Without Spark Advance Mechanisms	10-13
Timing Vacu-Flo Engines Without Spark Advance Mechanism	10-15
Engines With Spark Advance Mechanism	10-15
Spark Advance Mechanism	10-15
Timing Engines With Spark Advance Mechanism	10-16
Timing CCK Vacu-Flo Engines With or Without Spark Advance	10-16
BF-BG ENGINES AND BF POWER DRAWER SETS	10-17
Side Adjust Breaker Points (BF-BG Engines)	10-17
Top Adjust Breaker Points (BF-BG Engines)	10-18
Ignition Timing	10-18
NB ENGINE SERIES	10-19
Magneto Ignition	10-19
Breaker Points—Timing	10-19
NB Breakerless Ignition	10-20
Ignition Timing	10-20
NHA, NHB ENGINES AND NH POWER DRAWER SETS	10-21
Side Adjust Breaker Points	10-21
Ignition Timing	10-21
NHP-NHPV ENGINE SERIES	10-22
General	10-22
Top Adjust Breaker Points—Timing	10-22
Timing Check—Pressure Cooled Engine—NHP	10-22
Timing Check—Vacu-Flo Engines—NHPV	10-23

NHC-NHCV ENGINE SERIES	10-24
General	10-24
Timing Check—Pressure Cooled Engines	10-24
Timing Check—Vacu-Flo Engines	10-24
Top Adjust Breaker Points—Timing.....	10-25
NH ENGINE SERIES	10-26
Ignition Equipment	10-26
Side Adjust Breaker Points	10-26
Timing—Battery Ignition	10-26
Timing—Magneto Ignition.....	10-27
J-SERIES GASOLINE ENGINES	10-29
General	10-29
Testing	10-29
Battery Ignition (JB Electric and Remote Start Engines)	10-29
Breaker Points Mechanism	10-30
Magneto Ignition (JB, Manual Start)	10-31
Battery Ignition—JC, MJC, FJC Engines.....	10-32
Distributor	10-33
Breaker Points Adjustment	10-33
Timing JB-JC Vacu-Flo Engines.....	10-34
Dual Points and Coils.....	10-34
Dual Points Timing	10-35
Magneto Ignition	10-38
Fairbanks-Morse Magneto	10-38
Wico Magneto	10-38
SAFETY PRECAUTIONS FOR ALTERNATOR SYSTEMS	10-40
BATTERY CHARGING SYSTEMS	10-41
Flywheel Alternators	10-41
Description.....	10-41
General Troubleshooting Notes	10-41
Battery Check	10-42
Battery Voltage	10-42
20 AMP WICO System	10-42
Stator Output Check—Engine Running	10-43
Stator Winding Check—Engine Not Running	10-43
Flywheel Magnet Group or Rotor	10-43
DJC (Prior to Spec V) and DJB	10-43
Maintenance	10-44
Testing	10-44
Voltage Regulator	10-45
Indicator Light	10-45
Rectifier.....	10-45
Ammeter Test	10-45
20 Amp Synchro System	10-46
Rectifier Assembly Check	10-47
Regulator Assembly Check	10-47
9 and 15 Amp Pheion Systems	10-47
Testing	10-48
Belt Driven Alternators	10-51
Testing Diodes	10-51
SPARK PLUG MALFUNCTIONS	10-52
SPARK PLUG ANALYSIS	10-54

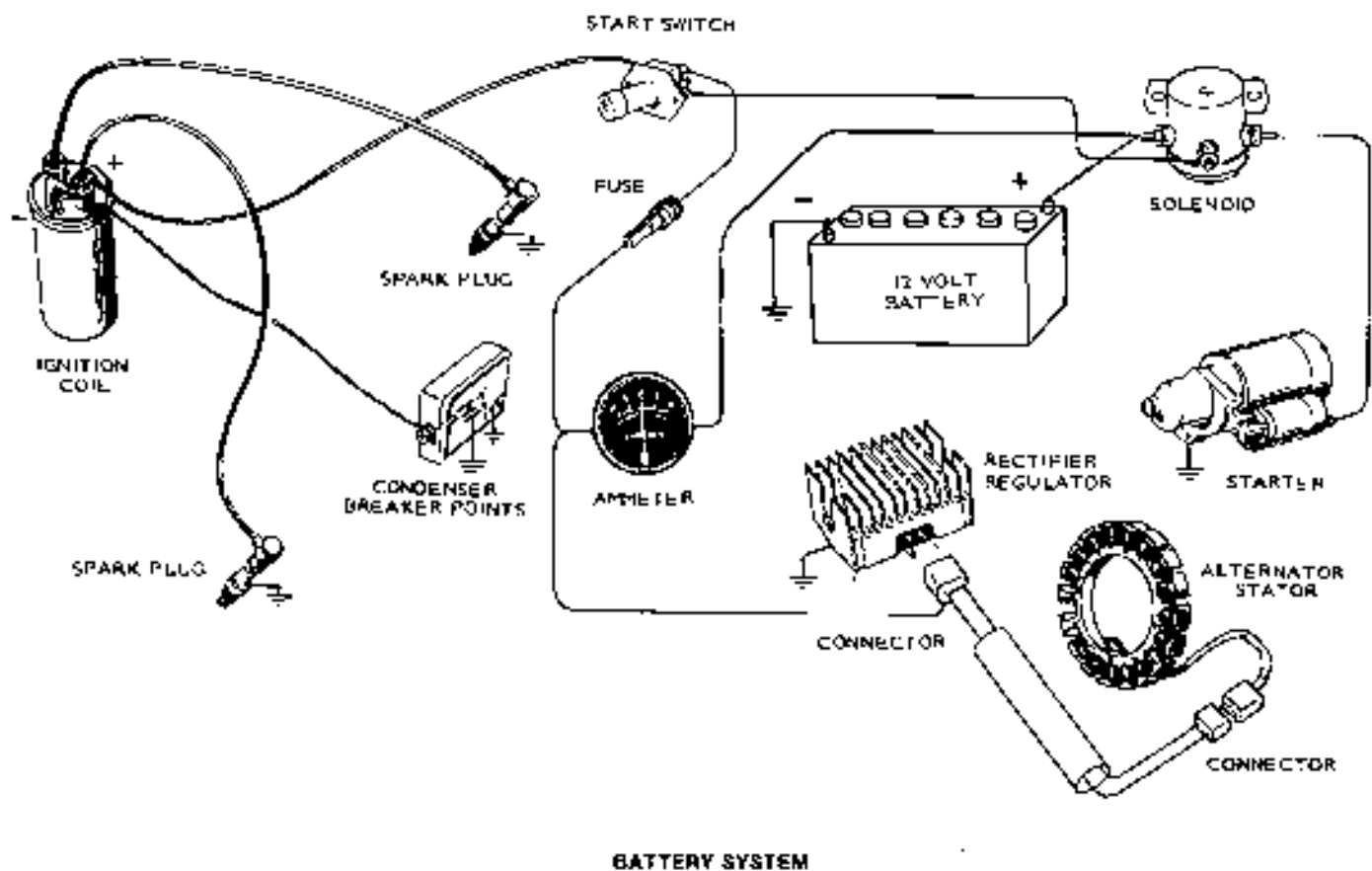

BATTERY SYSTEM

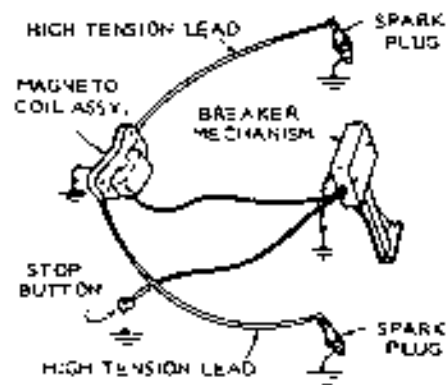
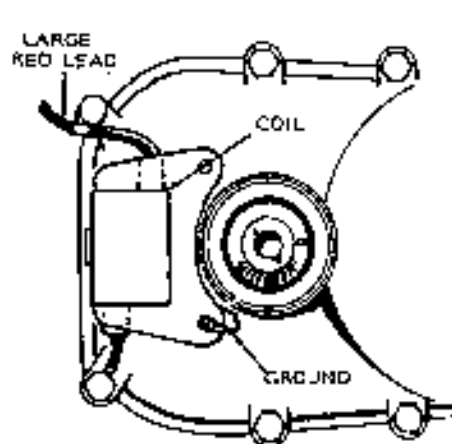

WITH SPARK ADVANCE MECHANISM

MAGNETO SYSTEM

FIGURE 10-1. TYPICAL IGNITION — CHARGING SYSTEMS

IGNITION SYSTEM DESCRIPTION

Ignition of the fuel-air mixture in an internal combustion engine is caused by a high voltage spark plug as the piston nears the top center of its compression stroke. The source of the electrical power for ignition voltage can be from either a magneto or a battery, and a DC generator or alternator. Figure 10-1. Magneto ignition systems are generally used on small engines which have no other requirements for electrical power such as a starting motor. Battery ignition systems are used on larger engines which can not be easily handcranked and have additional uses for the power a battery can supply. The heavy drain on a battery's current supply requires that an alternator or DC generator be a part of the engines electrical system to keep the battery charged.

Many of the engines in this section are equipped with either ignition system, magneto or battery, depending on the engines size and work load.

The electrical spark required for ignition must be of high voltage in order to jump the spark plug gap under high pressure, but the current flow can be relatively low. In either a magneto or a battery ignition system, the high voltage is produced by an ignition coil which has two separate windings. The primary winding has a few turns of heavy wire. The secondary winding has many turns of fine wire. Therefore, current flow at low voltage through the primary steps up to a very high voltage with low amperage as it is induced in the secondary. Whether the power source is a battery or a magneto doesn't matter.

What does matter are the interruptions in the primary current flow by the breaker points and the charging

and discharging of a condenser in the ignition circuit. These interruptions cause rapid changes in the coil. The changes in current flow produce high voltages (up to 20,000 volts) required by the spark plugs working under pressure and heat.

Exact timing of the spark with piston movement near the top of the compression stroke is essential for any engine to achieve maximum power and efficiency. Therefore, ignition timing depends upon the speed and design of each engine. Under normal running conditions, ignition occurs just before the piston reaches top center so that the progressive burning of fuel begins before the piston is driven downward on its power stroke by the hot, expanding gases.

IGNITION SYSTEM COMPONENTS

Magneto and battery powered ignition systems both use similar or even identical components and each of these components provide the same function in either ignition system. The major components of a typical ignition system are: a battery or magneto power source, low voltage wiring, high voltage spark plug leads, spark plugs, a single or twin coil, breaker points, and an ignition distributor on four cylinder engines.

Magnetos

A magneto is a small revolving field type generator. A laminated assembly and coil form the armature in which current is induced. A permanent magnet in the flywheel revolves around the armature and functions as the field. The current induced in the magneto coil completes its circuit through cam-operated breaker points to ground. This induced current is of a comparatively low voltage and cannot fire a spark plug. See Figure 10-2.

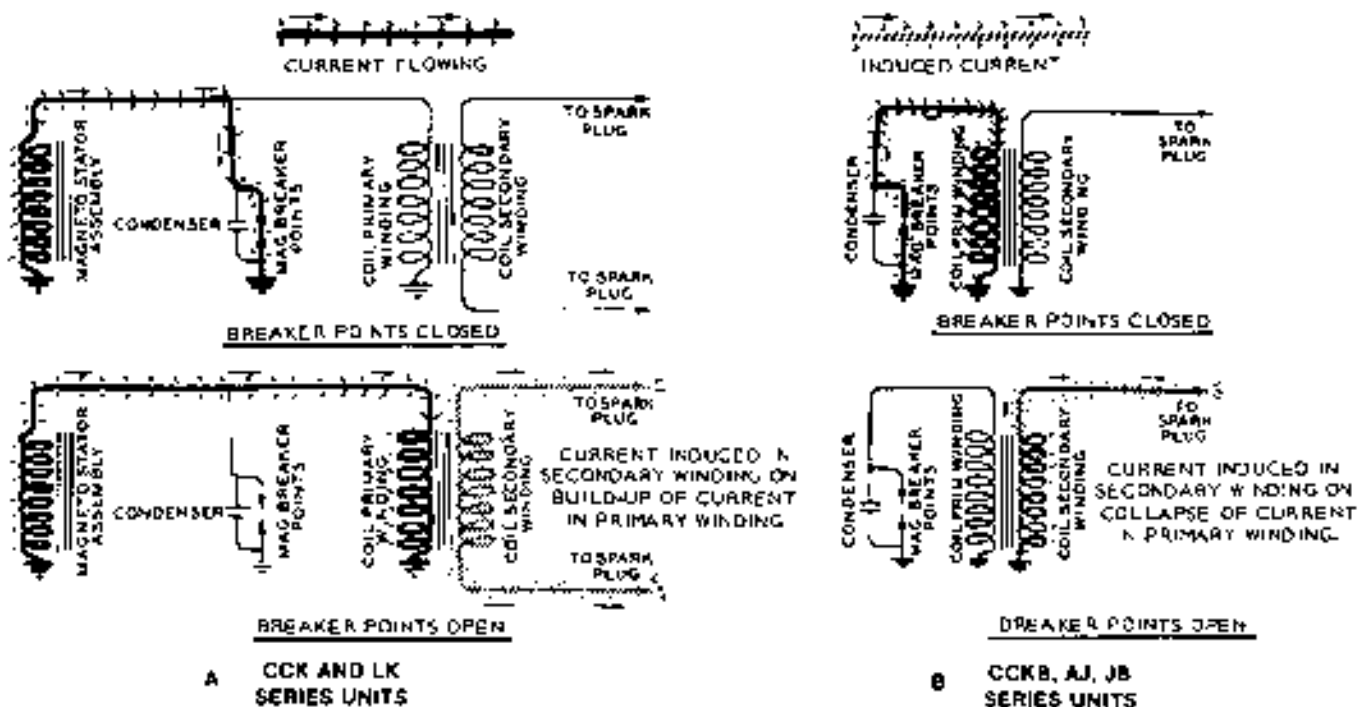

FIGURE 10-2. MAGNETO COILS

To step up the voltage to a usable point, a high tension winding is added, forming a transformer. Sometimes this high tension winding is wound on the same form with the magneto (low tension) winding (diagram A). An alternate method brings the low tension current out to a separate coil which contains both primary and secondary windings (diagram B). An advantage of the separate coil is that a battery can replace the magneto for special applications.

The operation of a set of breaker points, with a condenser in parallel, causes a change in current flow in the primary winding which in turn induces a high voltage in the high tension winding. This change can occur either on the buildup or collapse of the current in the primary winding. Units using the separate ignition coil use the break and buildup circuit. Units using the integral coil use the break and collapse circuit.

The breaker points must open at a time when the magneto is actually generating current — that is while the flywheel magnet is passing the armature. Also, because the change of current creates the high tension spark, the point break must occur at the proper firing time. The spark occurs at both spark plugs simultaneously on two cylinder engines. When one piston is at its firing position, the other piston is on its exhaust stroke. The spark that occurs in the exhaust stroke cylinder is "wasted", but eliminates the necessity for a distributor.

Timing the spark plug to fire when the breaker points separate, is critical to best engine performance. The spark must fire the fuel mixture at the split second when the piston is at the proper location in the cylinder to get the most power from the fuel charge.

Flywheel Magnet: The flywheel magnet (Figure 10-3) should retain its magnetism for the life of the unit. However, the magnet can accidentally be demagnetized. Hard blows or dropping can cause loss of magnetism. For this reason, a flywheel puller is preferred over the "knock off" method for removing a flywheel.

A more likely cause for loss of magnetism is an improper control panel connection on remote control generator sets, or by improperly converting a set using a separate high tension coil from magneto ignition to battery ignition.

On remote control type units, the engine stop (grounding) wire must lead only to the No. 2 terminal on the remote control terminal block. Number 1 terminal is a common ground and so the ignition circuit would be grounded if the stop wire were connected there. Remote terminals B+ and No. 3 are energized with battery positive current. If the engine stop wire were connected to either the B+ or No. 3 terminal, the battery current would flow through the magneto coil and, due to reversed polarity, tend to gradually weaken the magnet.

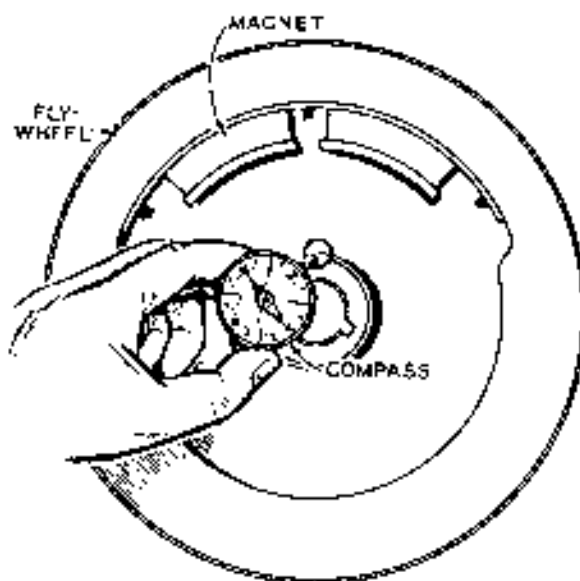

FIGURE 10-3 POLE ALIGNMENT

Remagnetizing the Flywheel Magnet: Many service shops have facilities for testing and charging flywheel magnets. In most cases, this shop equipment is adequate for charging any Onan flywheel magnet. However, some flywheel magnets require a very strong charge and if an attempt is made to recharge one of these on a small charger, the magnet may actually be weakened. Makeshift equipment will probably reduce the magnetism further. To recharge the magnet, it must have the correct polarity. The north seeking end of a compass needle must be attracted toward the leading magnet pole. If the magnetism is lost, return the flywheel to the factory for recharging.

A piece of steel held close to the magnets must be drawn strongly to them.

On single cylinder engines the magnet must be charged with correct polarity. All of the magnets on the single cylinder Onan engines are charged so that in checking with a magnetic compass, the NORTH seeking end of the needle should be attracted to the leading magnet pole. Be sure the charger is connected to charge with the correct polarity.

Wiring

Ignition wiring includes: one positive (B+) wire which carries the low voltage (6 or 12 volts) from the power source to the primary winding of the coil; one negative (-) wire which carries low voltage to the points and condenser (which may be in the distributor); and one or more high tension leads which carry the high voltage from the secondary winding of the coil to the spark plugs. The spark plugs, the condenser and the magneto coil are all grounded to

the engine making a complete circuit for the voltage back to the power source, Figure 10-1. The battery ignition coil is grounded through the breaker points and condenser.

Inspect ignition leads often for cracks or breaks in the insulation that may weaken the current before it reaches a plug, or a ground wire touching metal at some point may make operation unsatisfactory. If the coil terminal (or high tension lead attached to terminal) is too close to the pole shoe, (magneto coil) the spark may jump at this point.

Ignition Coils

The ignition coil is a transformer that steps up the battery voltage from about eight volts (normal voltage during engine operation) to about 20,000 volts for spark plug firing. The coil is composed of a core, a primary winding, insulators, secondary winding, sealing compound, bakelite cap, and the outside case and necessary terminals for primary and secondary windings. Figure 10-4.

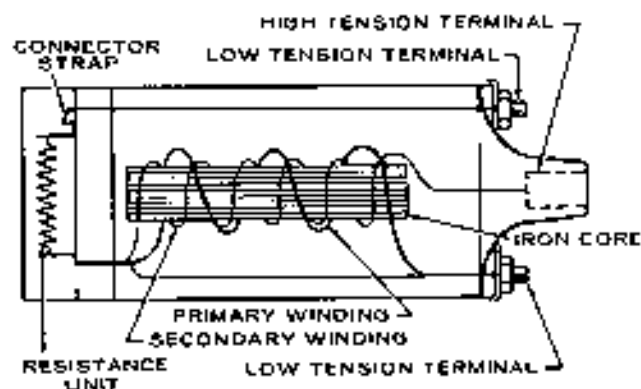

FIGURE 10-4. IGNITION COIL

The core of the coil is made up of a bundle of wires or laminations around which is wound the primary winding (a few turns of heavy gauge wire). The primary winding of the coil when energized by the battery creates the electromagnetic field that energizes the core of the coil to a certain magnetic strength.

If the breaker points are closed when the engine is switched on, current flows from the ungrounded post of the battery through the ammeter, through the primary winding of the coil and the primary lead to the points and back to ground on the engine. While the points remain closed, energy in the form of magnetic flux increases the magnetic strength of the coil until the points are opened by a cam or until saturation is reached.

As the points begin to open, the current tries to keep flowing in the primary circuit across the separating points because self-induction in the primary winding of the coil opposes any change in the amount of current flowing in the winding.

If it were not for the ignition condenser, connected across the points, the current would arc across the separating points, burning the points and draining off most of the energy just stored in the coil. Instead, the current charges the condenser during the first instant the points begin to separate and quickly stops the current flow in the primary. As the flow of current is halted, the magnetic fields in the coil decrease rapidly causing a high voltage to be induced in the primary and secondary windings of the coil. The high voltage is usually somewhere between 4,000 and 18,000 volts, the actual value depending on such variables as engine compression, speed, fuel mixture ratios, width of spark gap, spark plug temperatures, etc.

As each spark occurs at the plug gap the energy in the coil begins to drain rapidly through the secondary circuit and sustains the spark for a fraction of a second or for several degrees of crankshaft revolution. After the spark occurs at the plug gap following the point opening interval, the condenser discharges back through the primary circuit and the primary circuit returns to the normal battery voltage level to begin the next point closing and opening cycle.

The length of time that the points are closed and the primary current is flowing through the coil is called the "saturation period". The molecules in the iron core are being rearranged making the core into a magnet, the strength of which depends on the period of saturation. The shorter the time the points remain closed, the weaker the magnetic field will be.

When the breaker points open, stopping the current flow around the core of the coil, the core becomes demagnetized, its normal condition. The demagnetizing effect, which is a sudden change in the magnetic lines of force, is called the "collapse". Proper ignition timing is accomplished by a breaker-point mechanism actuated by a plunger and a cam on the camshaft.

Maintenance: Ignition coil terminals should be checked to make sure they are tight and in good condition. The coil insulation should be checked for burned or chipped places or cracks. The coil should be checked for loose soams, dents or punctures, and the coil tested electrically.

IGNITION COIL TESTS

Magneto and battery ignition coils can be tested either on or off of the engine using an ohmmeter or a magneto analyzer.

Coil Tests On The Engine

To test the coil on the engine, remove both spark plug leads; ground one to bare engine metal. Hold the other about 3/8 inch away from bare metal and crank the engine. A good spark should occur between the lead and engine. If not, the coil, flywheel magnets, or high tension leads are defective. Test the coil as follows:

1. With an ohmmeter, check resistance between lead to breaker points (disconnected from points), and a good ground on engine. Resistance should be about 0.6 ohms.
2. Remove both spark plug leads from plugs and measure resistance between the leads. Resistance should be about 11,000 ohms. If it is greater, either the leads or magneto high tension coils contain a high resistance or are open-circuited. The coil should be disconnected to test resistances of coil and leads separately. Inspect high tension terminals on coil for corrosion. If the resistance is low, the secondary winding is probably shorted and the coil must be replaced.
3. Check for shorting between primary and secondary circuits by measuring resistance from the breaker point lead to a spark plug lead. Any continuity indicates a defective coil.

CAUTION Onan engines use a 12 volt, negative ground system. The alternator must be connected to battery at all times when engine is running. Do not reverse battery cables.

Coil Tests Off of The Engine

The magneto coil is located behind the flywheel and is reached by removing the flywheel from the crankshaft using a flywheel puller. The battery ignition coil is usually clamped on the cylinder block and is easily removed.

GENERAL INSTRUCTIONS FOR TESTING A COIL

1. Remove engine magneto backplate assembly or ignition coil assembly.
2. Disconnect primary coil lead from breaker point assembly.
3. Disconnect high tension spark plug lead(s) at coil terminal.
4. Clean outside of coil with a cloth dampened in suitable solvent.
5. Inspect terminals for corrosion, looseness, cracks, dents or other damage. Look for evidence of electrical leakage (indicated by carbon runners) around high tension terminal. Coils found in this condition should be replaced.
6. Make a continuity test of coil windings with an ohmmeter. If this test indicates an open or short in the windings, replace coil.
7. When a coil passes all the above tests and still fails to operate, it should then be tested on coil and winding tester (magneto analyzer).

Before proceeding with tests refer to the tester manual for operating instructions.

CAUTION Do not use a 12-volt tester when testing 4-volt or 6-volt ignition coil because if the coil is connected to the tester for only a few seconds, it may burn out the windings in the coil! A 6-volt tester may be used but do not leave this coil on the tester over 15 or 20 minutes.

USING AN OHMMETER TO TEST COILS

To test primary and secondary windings within the ignition coil proceed as follows:

1. Use a Simpson 260 VOM or equivalent. Set ohmmeter at proper resistance scale.
2. Disconnect wires from spark plugs and connect one ohmmeter lead to each spark plug lead (wire). The ohmmeter reading should be 7,500 to 10,000 (10,800 to 31,200 ohms for coil number 166-0346). If unable to get a reading here, determine if the wires are at fault by connecting directly to the coil (hi-tension, castle terminals), Figure 10-5.

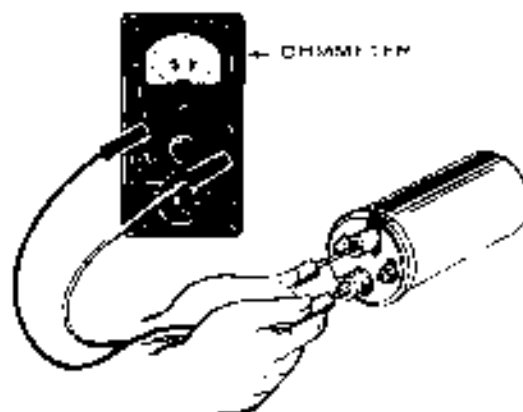

FIGURE 10-5. COIL TEST

3. If a spark plug wire is defective, install a new wire.
4. Install a new coil, if ohmmeter reads under 7,500 ohms or over 10,000 ohms (under 10,800 ohms or over 13,200 ohms for coil number 166-0346) when testing the secondary winding.
5. Use low scale on ohmmeter to check ignition coil primary winding.
6. Disconnect coil + and - primary leads and connect one ohmmeter lead to each terminal.
7. The ohmmeter should read .9 to 1 ohm; if not, install a new coil.
8. Set ohmmeter at its highest scale and connect one ohmmeter lead to a coil primary terminal and the other ohmmeter lead to either one of the coil secondary (hi-tension) terminals.
9. Disconnect all other coil leads.
10. There should be an infinite ohmmeter reading at this point.

11. If any of the above conditions are not met, replace coil. Refer to *PARTS CATALOG* for correct part number.

Refer to *Service Bulletin, Eng. 11 Section 20*, for additional coil test data.

BREAKER POINTS

The breaker points are a cam-operated switch that controls the exact timing of the ignition spark with each compression stroke of the pistons.

On breaker assemblies not mounted on a stator backplate (mounted separately on crankcase), a plunger actuates the points. If the plunger is worn or damaged, replace it. It may be necessary to shorten (dress) a new plunger to obtain the proper point gap. Clean the plunger if it becomes gummed up and causes irregular operation.

Breaker assemblies mounted on a stator backplate have a rubbing block that rides a cam surface on the crankshaft. Damage or wear of the rubbing block requires replacement of the point set.

Breaker Point Gapping

It is important that breaker points have the correct gap for easy starting, efficient operation, full power, proper cooling, etc. A retarded ignition causes overheating; an advanced ignition reduces efficiency.

Filing of points is not recommended. If filed, they must be polished smooth with a hone. Always check gap setting after servicing or replacing points. Points must be at full separation when checking gap. Points must be clean. The mating surfaces of breaker points must make contact evenly (Figure 10-6).

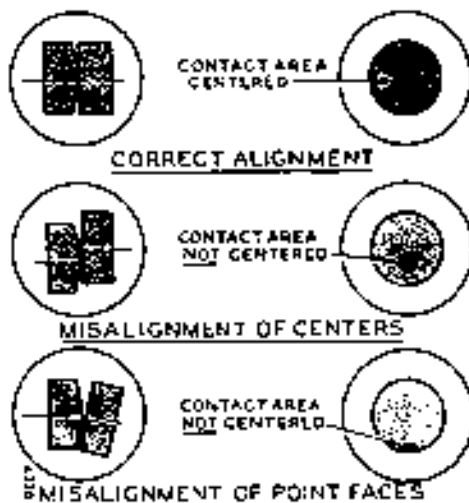

FIGURE 10-6. BREAKER POINT CONTACT

TESTING IGNITION COMPONENTS

The following test equipment is recommended for testing ignition components. Refer to *Tool Section 19* for tester data.

- Continuity Tester 420-0290
- AC-DC Multimeter Simpson 270
or equivalent 302-0195
- Magneto Analyzer 420-0235

The test units listed above are all good continuity testers, but the multimeter and the magneto analyzer are the most versatile units for testing all of the magneto and battery ignition system components and other electrical parts.

Continuity Testing

Continuity means a complete circuit exists, as it should, through the component or wire being tested. All continuity testers provide a separate low voltage source for "ringing" through individual electrical devices in checking for opens, shorts, or grounds that cause a component to be defective, Figure 10-7.

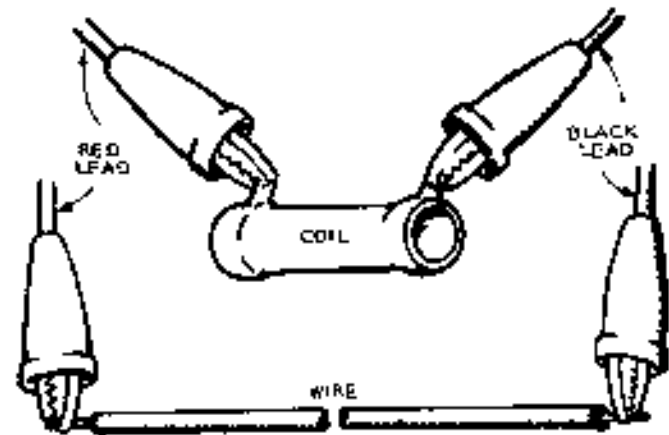

FIGURE 10-7. CONTINUITY TEST CONNECTIONS

Although continuity tests are quite simple, complications can result when the component being tested is connected to other circuit components by switches, relays, wires, or other electrical devices. For accurate results disconnect at least one end of the circuit being tested. Also, be certain that no voltage is applied to the device that could damage the tester.

Resistance Tests

Components such as resistors, coils, and lengths of wire that pass the continuity tests can be tested with an ohmmeter to determine their true resistance value. Components that do not meet the specified resistance values should be replaced without further consideration.

BATTERY CARE

CAUTION

Open engines use a 12 volt, negative ground system. The alternator must be connected to battery at all times when engine is running. Do not reverse battery cables. Damage to regulator or ignition coil could result if cables are reversed.

Inspect battery cells regularly. If cells are low on water, add pure or distilled water (no minerals) and recharge. If one cell is low, check case for leaks. Keep the battery case clean and dry. An accumulation of moisture will lead to a more rapid discharge and battery failure.

Keep the battery terminals clean and tight. After making connections, coat the terminals with a light application of petroleum jelly or non-conductive grease to retard corrosion. If battery will not hold a charge, replace it.

It is normal for an unused battery to self-discharge at a low specific rate in warm temperatures. The higher the charge, the higher the discharge rate.

CAUTION

A discharged battery (below 3/4 charge, 1.225 specific gravity) may freeze unless stored in a cool place above 32° F (0° C). Solid freezing of the electrolyte may crack the battery case and damage the positive plates.

Battery Testing

Two pieces of test equipment are readily available for testing lead-acid batteries: low voltage DC voltmeters and hydrometers.

Voltage Tests

A voltmeter, connected across the battery positive and negative poles will indicate its voltage before, during, and after charging. The voltmeter does not indicate the amount of charge.

Hydrometer Tests

A hydrometer (Figure 10-8) measures the specific gravity of the electrolyte in a battery, and thereby indicates how much electrical energy remains, or its state of charge. In cold or temperate climates at 80° F (26.7° C), a cell is fully charged when specific gravity is 1.265 times the weight of water; when specific gravity is only 1.120 times heavier than water, the cell is discharged. See Table 10-1. The electrolyte in most of today's new batteries is about 24% sulphuric acid by volume (35% by weight) and 76% water. The sulphuric acid content and the specific gravity of the electrolyte increases electro-chemically as the battery is charged up to maximum. Adding water, up to the proper level (1/4 to 1/2 inch [6 to 13 mm]) above separators in each cell temporarily lowers the specific gravity of the electrolyte. Low water does not mean the cell has lost any of its charge. The acid chemically combines with the soft lead plates during discharge periods and returns to the electrolyte during charging periods. Low water consumption indicates proper regulator settings.

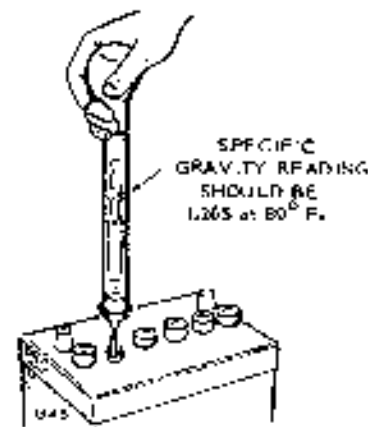

FIGURE 10-8. SPECIFIC GRAVITY TEST

CAUTION

Keep the battery electrolyte full up to the proper level to prevent damage to the plates. Avoid overfilling which can weaken the electrolyte. A battery that uses excessive amounts of water indicates overcharging which can damage the battery.

Table 10-1 shows typical Specific Gravity readings and percentages of normal charge at 80° F (26.7° C). A milder strength acid, less deteriorating to the separators and plates is used in tropical climates or where water never freezes, so the specific gravity of the electrolyte is lower overall.

TABLE 10-1

The following table gives the specific gravity values for typical batteries in various states of charge, these batteries having indicated gravities in the fully-charged state.

State of Charge	Specific Gravity as Used in Cold and Temperate Climates	Specific Gravity as Used in Tropical Climates
Fully Charged	1.265	1.225
75% Charged	1.225	1.185
50% Charged	1.190	1.150
25% Charged	1.155	1.115
Discharged	1.120	1.080

NOTE: 1. Always read the hydrometer in a vertical position with the surface of the electrolyte at eye level in the tube. Be sure the bulb floats in a sufficient amount of electrolyte and the electrolyte temperature compares with the temperature specified on the hydrometer for accurate results. The acid volume expands when warm and shrinks when cold so temperature is important when taking hydrometer readings.

Before reliable hydrometer readings can be taken, any added water must be thoroughly mixed with the heavier, underlying electrolyte by charging the battery prior to taking samples.

NOTE: 2. A battery with one or more cells that remain 0.050 specific gravity below the normal specific gravity readings, before and after charging, should be replaced.

NOTE: 3. Use tap water if it is free of scale-forming minerals; otherwise, add distilled water to the battery.

NOTE: 4. When water is added during freezing weather, the battery must receive a charge immediately to mix the water and electrolyte. If it is not mixed, the water will remain at the top and freeze.

NOTE: 5. Check the liquid level in each cell weekly by removing the vent plugs. Add water before the tops of the separators become exposed. **DO NOT OVERFILL.** See Figure 10-9.

NOTE: 6. Always keep the vent plugs in place and tight. Ensure the vent holes are free of dirt to allow gas pressure in cells to leave container.

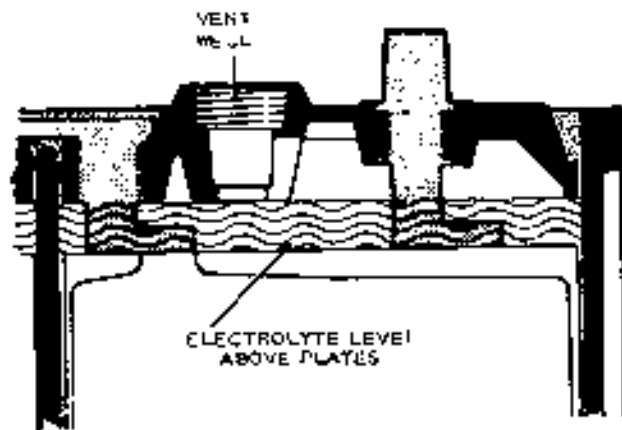

FIGURE 10-9. BATTERY ELECTROLYTE LEVEL

BATTERY HANDLING SAFETY — WARNINGS

WARNING

1. Always protect eyes, skin, and clothing against acid burns from spilled electrolyte when working with batteries. Keep lead acid batteries out of the reach of children.

SULPHURIC ACID ANTEDOTE:

External: Flush with lots of water.

Internal: Drink lots of water or milk; follow milk with milk of magnesia, beaten egg, or vegetable oil.

EYES: Flush eyes with water for 15 minutes and promptly get medical aid.

WARNING

2. Never wear rings or metal wristbands when working on batteries or electrical systems. Grounding a live circuit can be injurious to personnel.

WARNING

3. Do not permit smoking, sparks or flames near batteries especially during charging because hydrogen gas emitting from the cells is explosive. Always loosen vent caps on lead acid batteries during charging to allow gas bubbles to escape to the atmosphere. Refer to SAFETY Section at front of this manual for additional information.

SPARK PLUG MAINTENANCE

All Onan built engines use Onan spark plugs or equivalent standard automotive type plugs. Clean and inspect the spark plugs at regular intervals. Set the spark plug gap at 0.025 inch (0.64 mm) for gasoline and at 0.018 inch (0.46 mm) for gaseous fuel on the 1- and 2-cylinder engines, Figure 10-10. Set the spark gap at 0.035 inch (0.89 mm) on the 4-cylinder engines using either gasoline or gaseous fuel. When installing spark plugs, always use new plug gaskets. Install new spark plugs every 200 hours of operation.

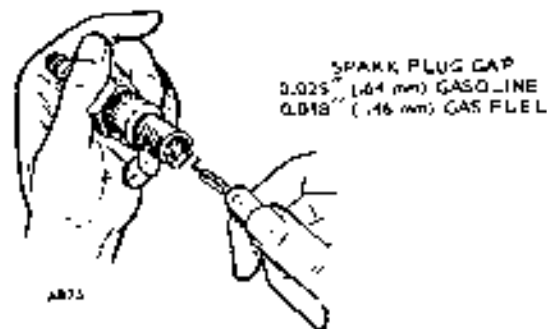

FIGURE 10-10. SPARK PLUG GAP

SPARK PLUGS

The spark plug is the medium through which the high tension or secondary voltage is converted into a spark to ignite the mixture of fuel and air in the combustion chamber of the engine. Spark plugs are subject to severe service during operation and require the same degree of careful inspection and care as the other components of the ignition system. See Figure 10-11 and pages 52-56 for spark plug service information.

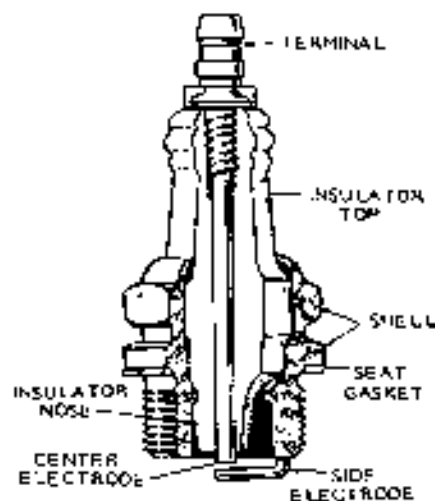

FIGURE 10-11. SPARK PLUG

AK, AJ, LK ENGINE SERIES

MAGNETO IGNITION

The single cylinder AK, AJ, and LK engines may be equipped with either magneto or battery ignition systems.

Magneto Removal

Access to the magneto ignition components involves removal of the air housings and blower wheel on the Vacu-Flu units or just the blower housings on the pressure cooled units. Loosen the flywheel bolt a few

turns. While pulling or prying outward on the flywheel, strike the flywheel bolt with a hammer. Remove the flywheel from the crankshaft. Examine the breaker points, Figure 10-12. Points which are not badly burned or pitted may sometimes be dressed smooth with a thin abrasive stone, or removed and dressed on any fine stone or hone. Badly burned or pitted points should be replaced. Adjust the gap between points at full separation as given in the

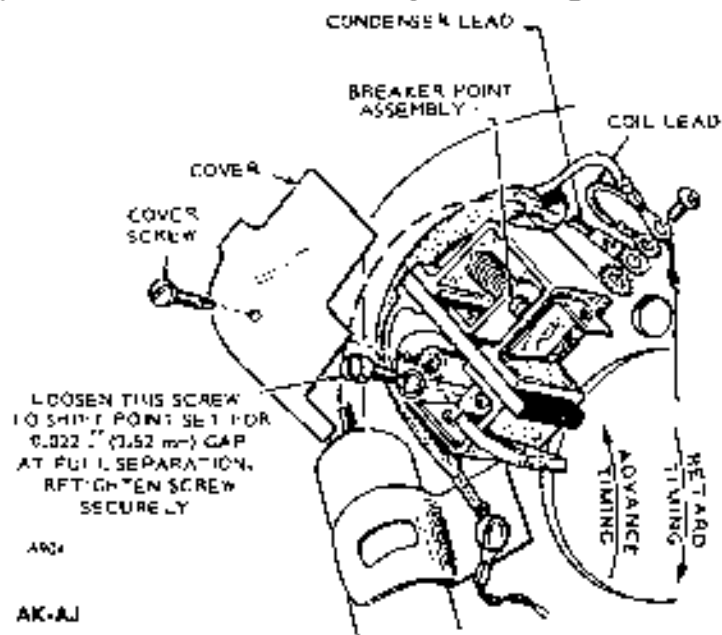
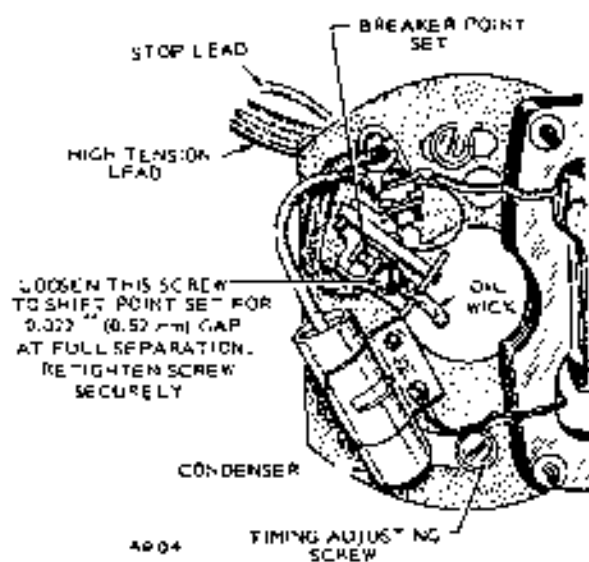

FIGURE 10-12. BREAKER POINTS

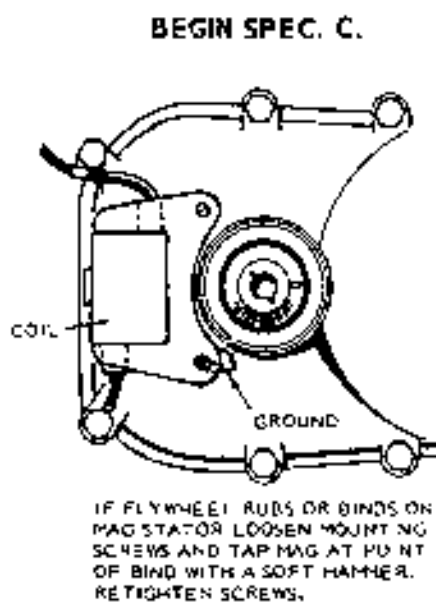
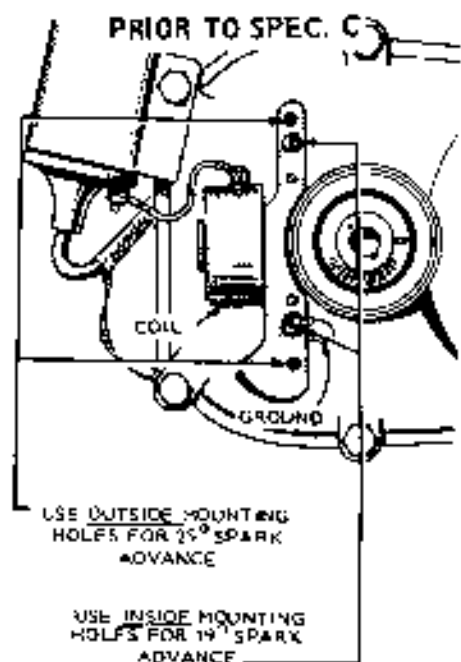
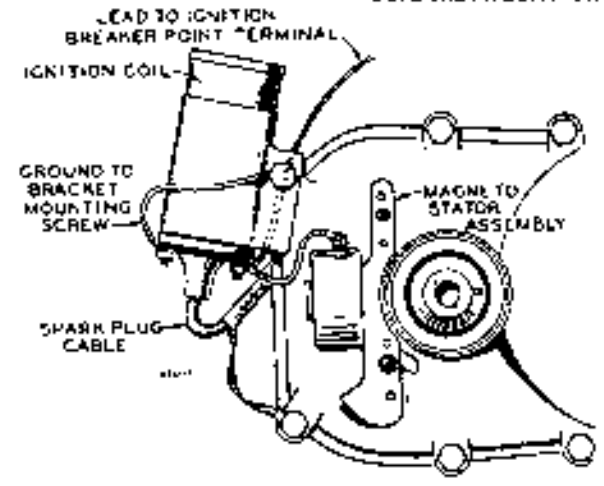

FIGURE 10-13. MAGNETO STATOR INSTALLATION

REV. 11-78

**PRIOR TO SPEC C
MAGNETO IGNITION
COIL INSTALLATION**



**TO SPEC E
BATTERY IGNITION
COIL INSTALLATION**

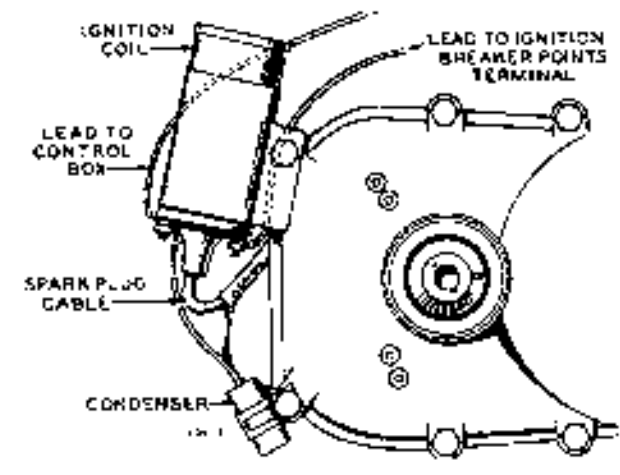

BEGIN SPEC E

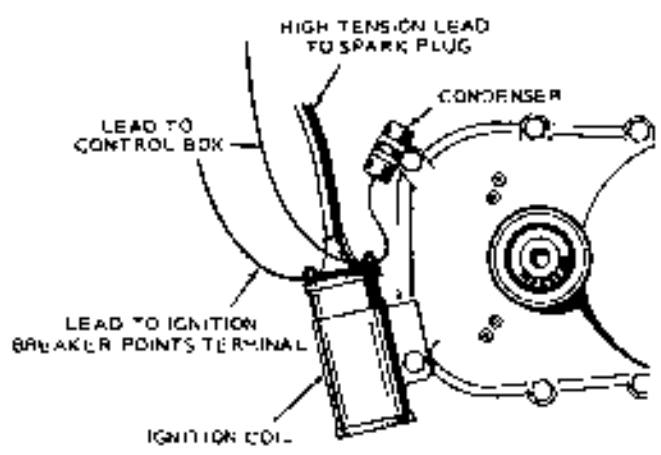

FIGURE 10-14. IGNITION COIL INSTALLATION (LK)

SPECIFICATIONS section of this manual. A defective condenser must be replaced with a new one of proper capacity. A flywheel magnet that has lost its magnetism should be remagnetized. If the magneto backplate has been loosened or removed, check the gap between the coil post holes and the flywheel. It should be .010 inch to .015 inch (0.25 to 0.38 mm). Too wide a gap will produce a weak spark.

Stator Installation

The stator is mounted behind the flywheel, Figure 10-13. It has two pair of mounting holes. Use the inside mounting holes for 19° spark advance. Connect the smaller coil lead (ground) to the stator mounting screw. Connect the larger coil lead to the ignition coil (either terminal). Be sure that the larger lead does not rub on the flywheel.

Coil Installation

See Figure 10-14 for coil connections for magneto ignition and battery ignition. The ignition coil is grounded on magneto ignition systems and not grounded with battery ignition systems. Spark occurs at the buildup of magneto current and at the collapse of battery current.

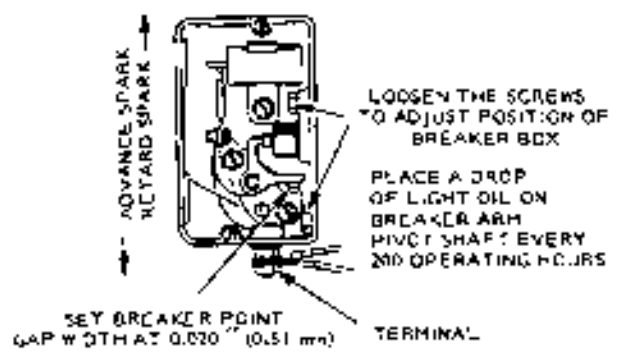

FIGURE 10-15. TIMING MARK AND BREAKER POINTS

Timing

Ignition timing is the same for manual-start engines with magneto ignition and remote-start engines with 12 volt battery ignition, Figure 10-15.

Replace burned or faulty points. If only slightly burned, dress smooth with file or fine stone. Measure gap with thickness gauge. Set gap at .020 inch (0.51 mm).

The spark advance is 19° before top center for all models. Set ignition timing as follows:

1. Remove breaker box cover.
2. Crank engine slowly by hand in direction of crankshaft rotation until painted witness mark on flywheel and TC mark on gear cover are exactly in line on the compression stroke, Figure 10-15.
3. Ignition breaker points must be correctly gapped. Crank engine to fully open breaker points (1/4 turn after top center). Loosen and move stationary contact to correct gap at full separation. Tighten contact and check gap.
4. Turn flywheel to left, against crankshaft rotation, until TC mark is about two inches past 25° mark on gear cover.

5. Turn flywheel slowly to right and note whether ignition points just separate when mark on flywheel aligns with 19° mark on gear cover (engine must be on compression stroke). If marks align as the points break, timing is correct. If not, loosen the breaker box mounting screws and shift the breaker box assembly slightly upward to retard the timing (points breaking too soon), or slightly downward to advance the timing (points not breaking soon enough).
6. Tighten the breaker box mounting screws securely after making an adjustment.
7. To accurately check timing with engine running, use an automotive type timing light.
8. To check timing without running the engine, connect a continuity tester across the breaker points. Touch one test prod to breaker box terminal (to which the lead to the coil is connected), and the other test prod to a good ground on engine. Turn crankshaft against rotation (backwards) until the points close. Then slowly turn crankshaft with rotation (forward) until points close. The lamp should go out just as the points break open.
9. Install breaker box cover.

ANTI-FLICKER MECHANISM

The anti-flicker mechanism is used on 1500 or 1800 rpm AC generator sets, to compensate for the power surge during the power stroke of the engine. The breaker points, located on the left side of the crankcase just behind the gear cover, are connected to a generator field resistor. A condenser connected

across the breaker points prevents sparking and burning of the contacts. Burned or pitted contact points are usually an indication of a defective condenser. The breaker point gap at full separation should be 0.020 inch (.51 mm). If points and condenser are in good condition, but light flicker is excessive, check for a defective resistor.

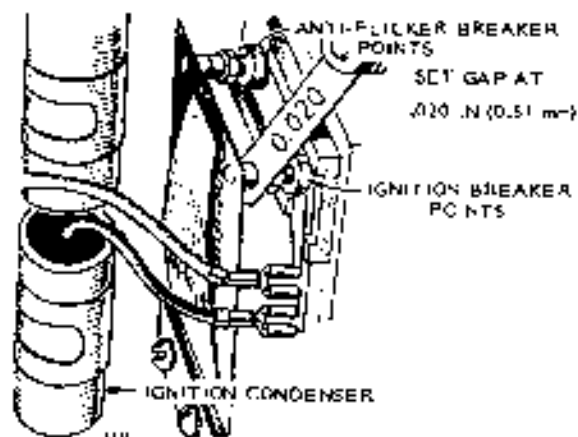
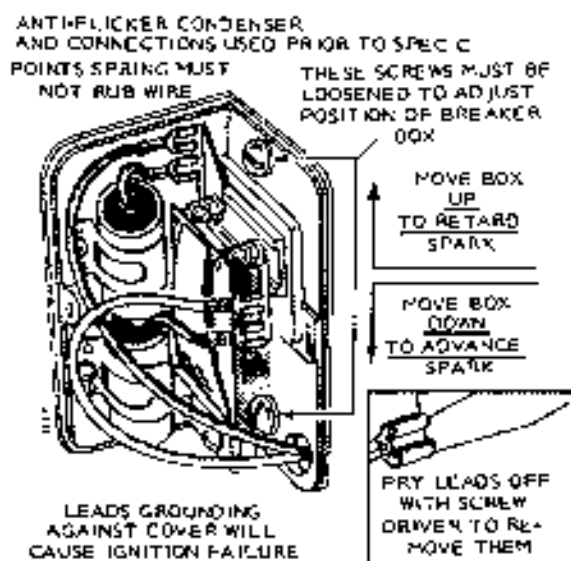

ANTI-FLICKER MECHANISM

REV. 11-76

BATTERY IGNITION (2.7 AJ ENGINES)

TIMING AND BREAKER POINTS

The breaker points should open at 22° BTC (see Figure 10-16.) Proper 22° BTC timing is obtained by setting breaker points and checking with a timing light.

The 22° BTC timing can be checked at timing hole on the front of blower housing (D) or at another timing hole on the side of the blower housing (C) just above the governor adjustment. Breaker point setting may vary from .017 - .024 inch (0.43 to 0.61 mm) to get proper 22° BTC timing.

1. Turn engine over slowly in a clockwise direction until the TC mark appears in middle of timing hole (D). Turn slightly beyond this point to ensure points are fully open.
2. Remove cover on breaker point box, loosen screws A and turn cam screw B to obtain .020 inch (0.51 mm) setting. Use a clean, flat feeler gauge.
3. Retighten screws A, replace breaker box cover and connect a timing light. With unit running and warmed up, notch should appear in timing hole C. (If front of blower scroll is accessible, direct the timing light to timing hole D. The 22° BTC mark should appear in this hole.)

SET BREAKER POINT GAP WIDTH AT .017 - .024 (.43 TO 0.61 mm) TO GET PROPER 22° BTC TIMING

PLACE A DROP OF LIGHT OIL ON BREAKER ARM PIVOT WHENEVER POINTS ARE INSTALLED OR ADJUSTED.

To adjust gap, loosen screws "A" with cam "B".

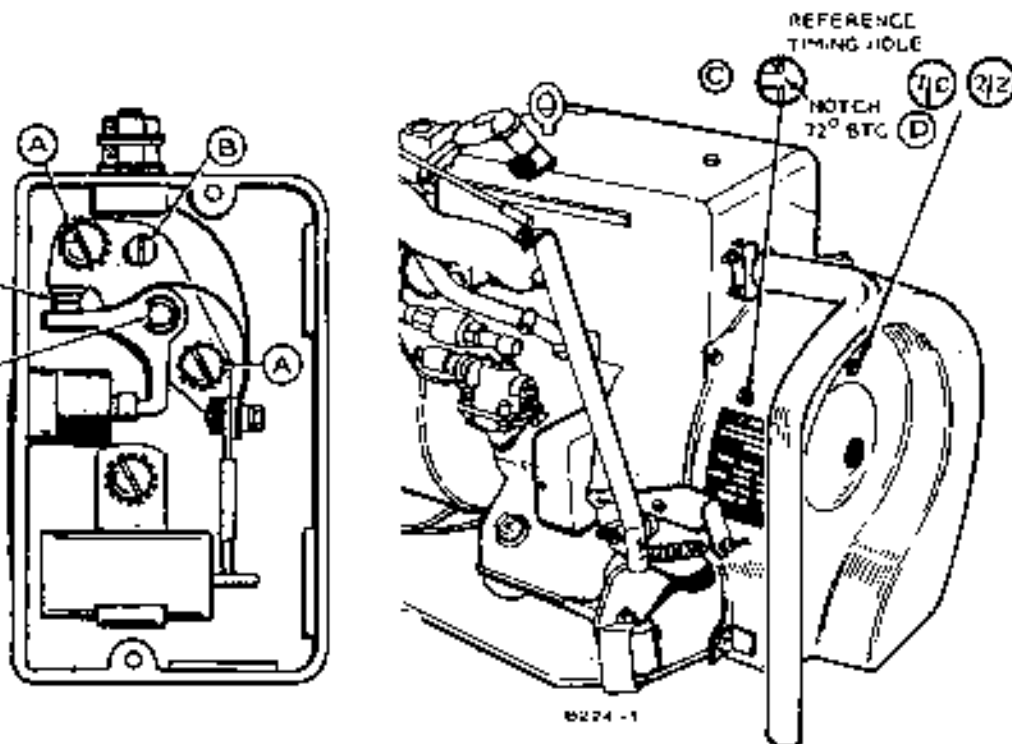
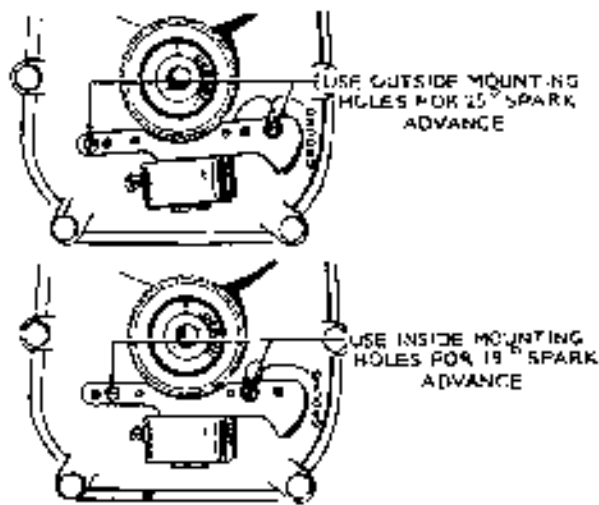

FIGURE 10-16. IGNITION AND TIMING ADJUSTMENTS (2.7 AJ VACU-FLO)

CCK, CCKA, CCKB, AND RCCK ENGINE SERIES



4649

If flywheel rubs on pole shoe loosen pole shoe mounting screws, tap pole shoe and retighten mounting screws.

A — MAGNETO STATOR ASSEMBLY

WARNING Do not use a 12 volt coil tester on CCK engines prior to Spec V or coil damage may result; use a 8 volt coil tester for these models. On CCK engines, beginning with Spec V, use a 12 volt coil tester.

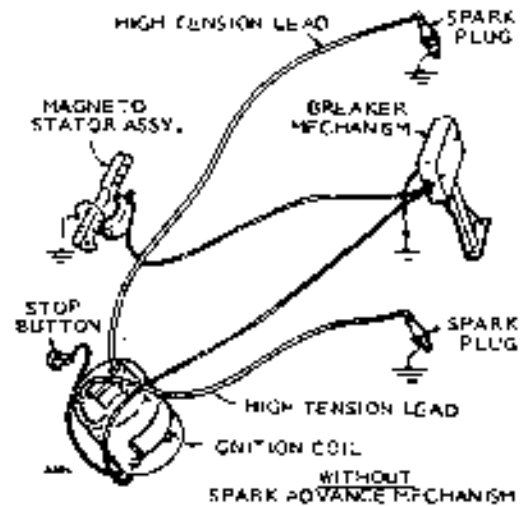

B — MAGNETO SYSTEM

FIGURE 10-17. MAGNETO IGNITION SYSTEM

GENERAL

The CCK series engines use a variety of different magneto and battery ignition systems. Some have a spark advance mechanism; some do not. In either case, the correct ignition timing position is stamped on the cylinder block near the breaker box. When the magneto ignition system is used, the stator assembly is mounted on the gear cover behind the flywheel.

ENGINES WITHOUT SPARK ADVANCE MECHANISM

These engines have a separate automotive type coil and are identified by a flat cover which is flush with the crankcase. The flywheel must be removed to expose the magneto stator assembly. The stator (Figure 10-17A) has two pairs of mounting holes. The innermost holes give 19° spark advance for engines with speed range of 1500 to 2400 rpm. The outermost holes give 25° spark advance for engines with speed range of 2500 rpm and above. Connect the smaller (ground) coil lead to the stator mounting screw.

Coil connections differ between magneto ignition engines and battery ignition engines. Refer to Figures 10-17B and 10-18A. The ignition coil is grounded on magneto ignition engines, but not grounded with battery ignition.

TIMING—CCK SERIES (Without Spark Advance Mechanism)

The ignition timing procedure is the same for manual-start engines with magneto ignition as for electric-start engines with 12 volt battery ignition.

The timing mark is 10° before top center for all models with engine speeds ranging from 1500 to 2400 rpm. Models with engine speeds of 2500 rpm and up use the 25° timing mark.

On engines with Vacu-Flo cooling, access to timing marks is obtained by removing the sheet metal plug from the top of the engine air housing. The timing marks, 19° and 25° are stamped on gear cover. Timing procedure follows:

1. Remove cover from breaker box (Figure 10-18B) to expose points and condenser. If the timing is very far off, attain an approximate setting by loosening the mounting screws and shifting the breaker box (and spacer if used) to align the witness marks on cylinder block and breaker box (or spacer).
2. Crank engine slowly by hand in direction of crankshaft rotation until timing mark on the flywheel and TC mark on gear cover are exactly in line, Figure 10-19.

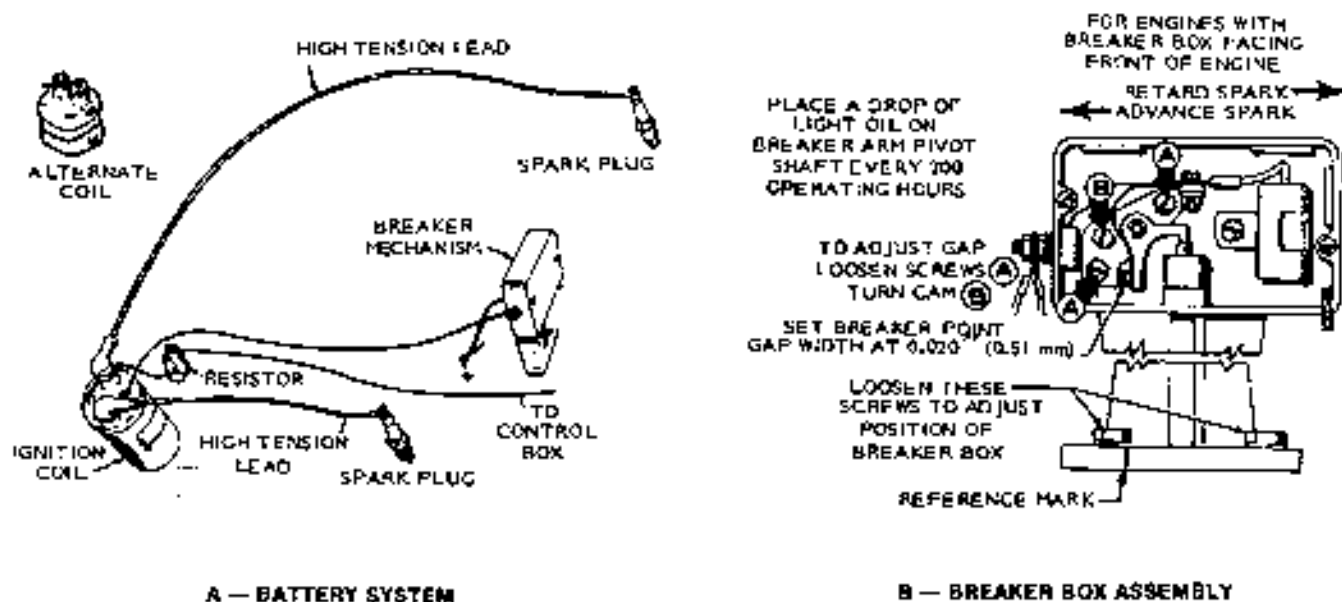

FIGURE 10-18. BATTERY IGNITION SYSTEM — WITHOUT SPARK ADVANCE MECHANISM

3. Adjust ignition breaker point gap to .020 inch (0.51 mm) at full separation.
4. Turn flywheel to left, against crankshaft rotation, until timing mark is about two inches past 25° mark on gear cover.
5. Turn flywheel slowly to right and note whether the ignition points just separate when the mark on flywheel aligns with correct degree mark (19° or 25°) on gear cover. If the marks align as the points break, timing is correct. If they do not, loosen the breaker box mounting screws and shift the whole breaker box assembly slightly toward the #1 cylinder to retard the timing (points breaking too soon), or shift it slightly away from the No. 1 cylinder to advance the timing (points not breaking soon enough).
6. Tighten breaker box mounting screws securely after making an adjustment (Figure 10-18).
7. To accurately check time at which spark occurs, an automotive type timing light may be used when the engine is running.
8. To accurately check the time at which spark occurs when not running the engine:
 - a. Connect a continuity tester across the ignition breaker points.
 - b. Touch one test prod to breaker box terminal (to which lead to coil is connected) and touch the other test prod to a good ground on engine.
 - c. Turn crankshaft against rotation (backwards) until points close.
 - d. Then slowly turn crankshaft with rotation.
 - e. The lamp should go out just as points break.
9. Reinstall breaker box cover.

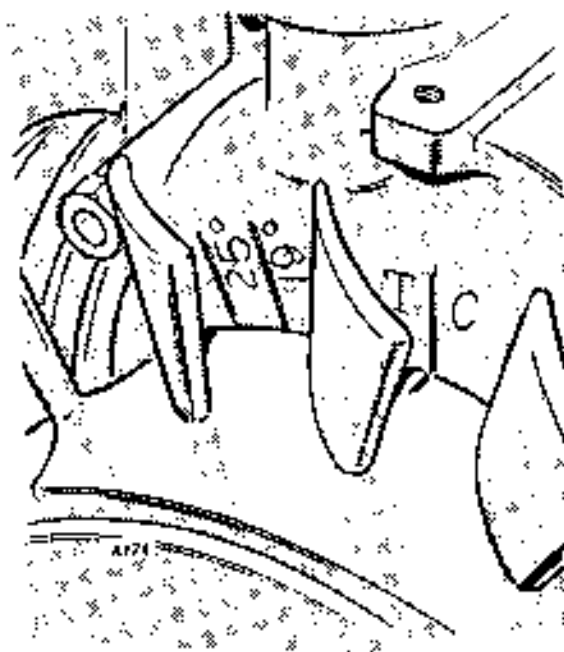

FIGURE 10-19. TIMING ENGINES WITHOUT SPARK ADVANCE

TIMING — VACU-FLO ENGINES WITHOUT SPARK ADVANCE MECHANISM

1. Remove dot button from top of blower housing, Figure 10-20.
2. Connect a timing light to either plug.
3. Start engine and run it at 1400 to 1600 rpm.
4. Viewing timing marks through round hole in blower housing, and using a timing light, TC (top center) flywheel mark should align with the 24-25° mark on gear cover.
5. If timing is incorrect, shift breaker box until correct timing is achieved.
6. Replace dot button.

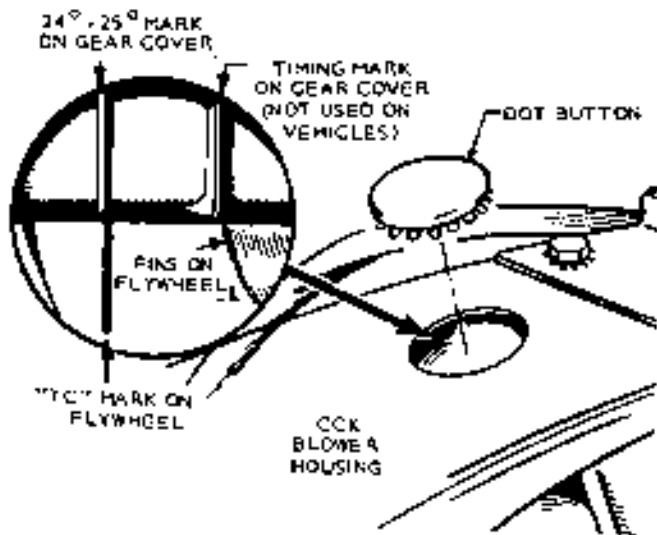

FIGURE 10-20. VACU-FLO IGNITION TIMING

ENGINES WITH SPARK ADVANCE MECHANISM

These engines are identified by a raised cup-shaped cover on the upper rear of the crankcase below the breaker box. When the magneto ignition system is used, the stator assembly is mounted on the gear cover behind the flywheel. Beginning Spec G, two washers are used on both mounting screws, between the gear cover and the stator assembly. Remove the flywheel to expose the stator assembly.

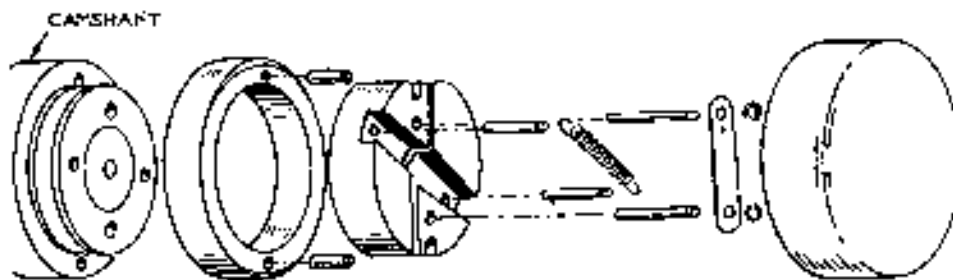

FIGURE 10-22. SPARK ADVANCE MECHANISM

The stator coil in these units has both a primary and a secondary winding. Therefore, a separate automotive type coil is not used.

The (larger) stator lead connects to the insulated terminal on the breaker box, Figure 10-21. Secure the stator lead properly to prevent it from rubbing on the flywheel. The smaller lead is grounded to the cylinder block.

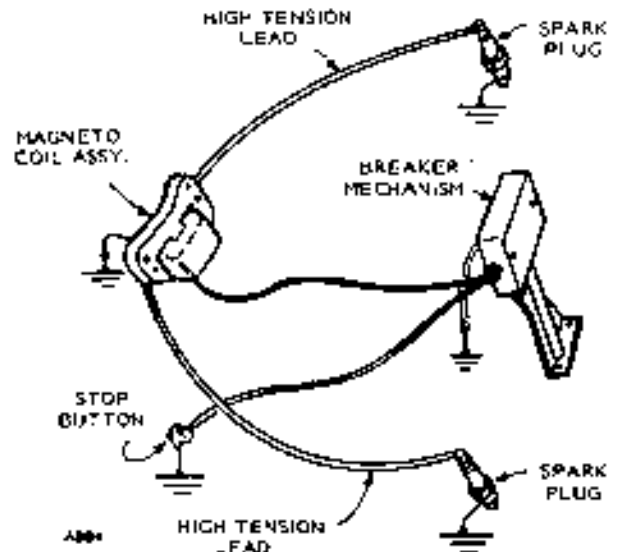

FIGURE 10-21. MAGNETO IGNITION WITH SPARK ADVANCE MECHANISM

SPARK ADVANCE MECHANISM

The spark advance mechanism, located on the rear end of the camshaft, is operated by centrifugal force, Figure 10-22. As engine speed increases weights push the cam to advance the spark, or release the cam retarding the spark as engine speed decreases.

If the spark advance mechanism should become dirty or gummy, causing the mechanism to stick closed (retarded), the engine will lack power. If the mechanism sticks open (advanced), the engine may possibly kick back on cranking. The spark advance mechanism can be reached for cleaning by either removing the cup shaped cover in the crankcase near camshaft opening (exposing the mechanism) or by removing camshaft from engine. Do not dent the cup shaped cover as it will interfere with the weight mechanism.

CAUTION

A 6 volt tester must be used to test the ignition coil. To avoid burning out the coil, do not use a 12 volt tester and do not leave coil on the six volt tester over 15 or 20 minutes.

TIMING (Engines with Spark Advance Mechanism)

The correct timing (5° stopped or at idle speed; 24° running at 1100 rpm or over) is stamped on the cylinder block near the breaker box. If the breaker points separate when the timing marks align (engine stopped), timing is correct. Timing is best adjusted with an automotive type timing light while the engine is running.

- **Timing Marks on Gear Cover:** Align the correct timing mark on the gear cover with the TC mark on the flywheel, Figure 10-23.
- **Timing Marks on Both Gear Cover and Flywheel:** Align either the TC flywheel mark with the correct timing mark on the gear cover or the correct timing mark on the flywheel with the TC mark on the gear cover, Figure 10-23.

Use only one TC mark and one set of timing marks.

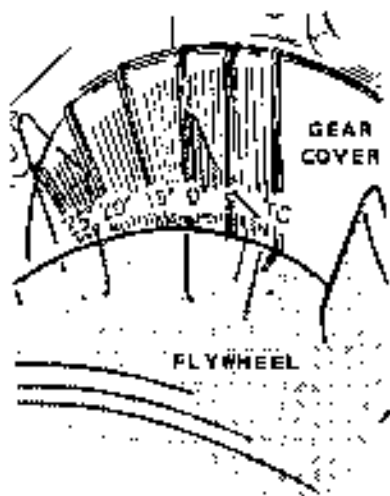
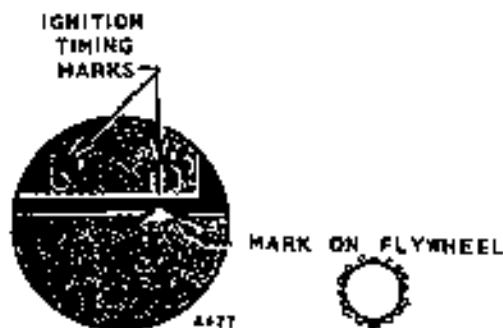

FIGURE 10-23. TIMING MARKS — CCK, CCKA AND CCKB WITH SPARK ADVANCE MECHANISM

TIMING CCK VACU-FLO ENGINES WITH OR WITHOUT SPARK ADVANCE MECHANISM

1. Remove dot button from blower housing, Figure 10-24.
2. Connect timing light to either spark plug.
3. Start engine and run it at 1400 to 1600 r/min.
4. Viewing timing marks through round hole in blower housing, and using a timing light, TC (top center) flywheel mark should align with the 25° mark on gear cover, Figure 10-24.
5. While watching timing marks with timing light, slow engine to below 800 rpm. If TC mark on flywheel disappears and then reappears when engine is brought back to speed, the spark advance mechanism is operating properly.
6. If spark advance mechanism does not react as outlined in Step 4, remove, clean and/or replace as necessary.
7. Replace dot button.



A — WITHOUT SPARK ADVANCE

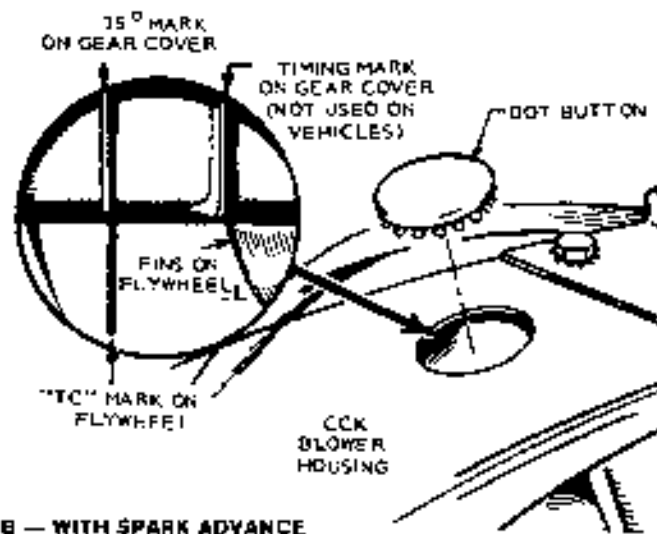

B — WITH SPARK ADVANCE

FIGURE 10-24. VACU-FLO IGNITION TIMING

REV. 11-78

BF-BG ENGINES AND BF POWER DRAWER SETS

The BF-BG engines and the BF Power Drawer electric generating sets are equipped with battery ignition systems with either side adjust or top adjust breaker points. The breaker point gap and the timing mark positions are not the same on all of these engines.

SIDE ADJUST BREAKER POINTS (BF-BG ENGINES)

To maintain maximum efficiency from the engine, change the breaker points every 200 hours of operation. Proceed as follows when engine is cold:

1. Remove two screws and cover on breaker box.
2. Remove spark plugs so engine can be easily rotated by hand. Check condition of spark plugs at this time.
3. Refer to Figure 10-25. Remove mounting nut (A) and pull points out of the box just far enough so screw (B) can be removed and leads disconnected.
4. Remove screw (C) and replace condenser with a new one.
5. Replace points with a new set but do not completely tighten mounting nut (A).
6. ON INDUSTRIAL ENGINES: Remove air intake hose that connects to blower housing. This provides an access to view timing mark, Figure 10-26.
7. ON POWER DRAWER UNITS: Remove dot button on blower housing. This provides access to view the timing mark, Figure 10-27.
8. Remove the air intake hose that connects to blower housing. This provides an access to view timing mark.
9. Rotate crankshaft clockwise (facing flywheel) by hand until timing mark on gear cover aligns with mark on flywheel. Turn another 1/4 turn (90 degrees) to ensure points are fully open.

The timing mark on the gear cover is different for each of the following engines:

- BG-Set Timing at 21° BTC
- BF-Set Timing at 25° BTC
- BF Power Drawer Set Timing at 26° BTC

10. Using a screwdriver inserted in notch (D) and a clean feeler gauge, adjust point gap to: 0.020 to 0.023 inch (0.51 to 0.58 mm) on BG engines or .025 inch (0.64 mm) on BF engines.
11. Check ignition timing.

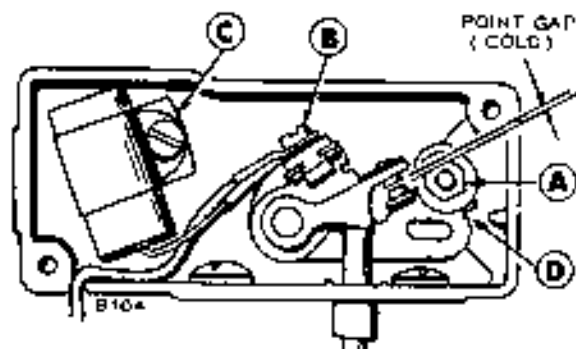

FIGURE 10-25. SIDE ADJUST POINTS

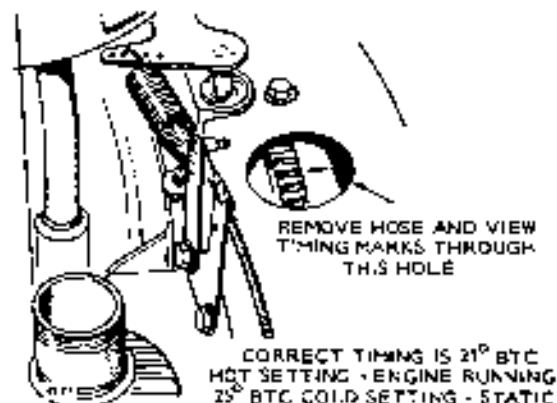

FIGURE 10-26. TIMING MARK — BF-BG ENGINES

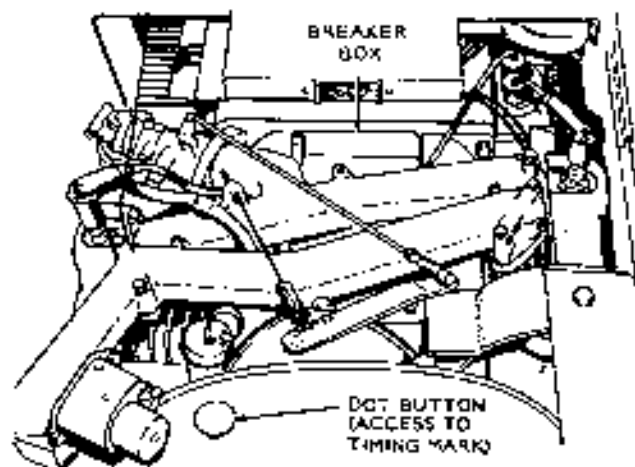

FIGURE 10-27. BF POWER DRAWER TIMING MARK

TOP ADJUST BREAKER POINTS (BF-BG ENGINES)

To maintain maximum engine efficiency, check the breaker points every 100 hours of operation and replace if necessary. Proceed as follows:

1. Remove spark plugs and rotate flywheel TC mark to 21° BTC (points open); then rotate it another 90 degrees clockwise to ensure points open fully.
2. Remove breaker box cover and unplug coil wire at coil (+) terminal.
3. Remove condenser (screw A) and detach condenser lead and coil lead (screw B), Figure 10-28.
4. Remove two Allen screws (C) and lift breaker assembly from engine.
5. Replace condenser and point assembly with new parts and reinstall using above procedure in reverse order of removal.
6. Using Allen wrench at screw (D) adjust point gap at .021 inch (0.53 mm) using a clean, flat thickness gauge.

Setting point gap accurately adjusts engine timing.

7. Replace breaker box cover and spark plugs.

If desirable, check ignition timing with a 12 volt test light or continuity tester.

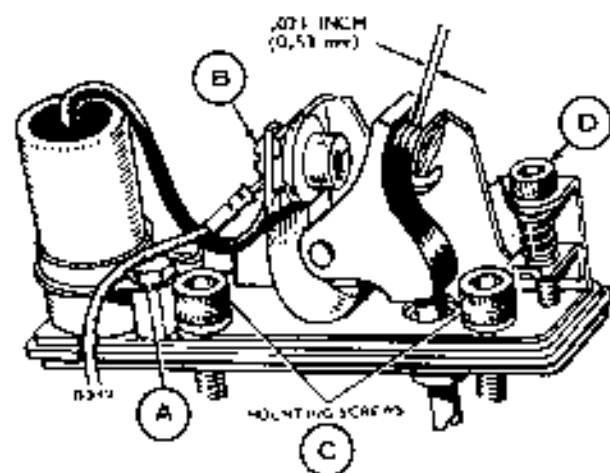

FIGURE 10-28. TOP ADJUST POINTS

IGNITION TIMING

The engine timing is preset at the factory. A non-movable breaker point box is used, however a slight timing change could be made by adjusting points.

Spark advance is set at 21° BTC (before top center) and should be maintained for best engine performance. Always check timing after replacing ignition points or if noticing poor engine performance. Proceed as follows:

Timing Check—Engine Running

1. To accurately check ignition timing, use a timing light with engine running at idle speed. Connect timing light according to its manufacturer's instructions. Either spark plug can be used as they fire simultaneously.
2. Remove air intake hose from shroud, Figure 10-29.
3. Start engine and check timing. The timing mark on the flywheel should center in the intake hose hole in the shroud.
4. Reinstall air intake hose.

Timing Check—Engine Not Running

If a timing light is not available, check the timing as follows:

1. Connect a continuity tester across the ignition breaker points. Touch one test prod to breaker box terminal to which the coil lead is connected and touch the other test prod to a good ground on engine.
2. Turn crankshaft against rotation (counterclockwise) until the points close. Then slowly turn the crankshaft with rotation (clockwise).
3. The lamp should go out just as the points open which is the time at which ignition occurs:
 - 21° BTC on top adjust BG engines
 - 25° BTC on all BF engines
 - 21° BTC on side adjust BG engines
 - 26° BTC on BF Power Drawer engines



FIGURE 10-29. BF-BG FLYWHEEL TIMING HOLE

NB ENGINE SERIES

MAGNETO IGNITION

On manual start NB models a magneto ignition is used. On electric start models an automotive type battery ignition is used.

BREAKER POINTS—TIMING

Measure the point gap with a thickness gauge and set at .020 inch (0.51 mm). To set the gap, crank the engine to fully open the breaker points (1/4 turn after top center). Loosen and move stationary contact to correct the gap at full separation. The mating surfaces of breaker points must make contact evenly. Point alignment is extremely important to proper engine operation and point life.

Adjustment of the breaker points affects the time that contacts are opened and closed. Timing of the spark plug firing, which occurs when the breaker points separate, is critical to best engine performance. The spark must fire the fuel mixture at the split second when the piston is at the proper location in the cylinder to get the most power from the fuel charge. Set the ignition timing as follows:

1. Remove breaker box cover.
2. Crank engine slowly by hand in direction of crankshaft rotation until top center mark on flywheel and 22° mark on gear cover are exactly in line on the compression stroke, Figure 10-30.
3. Adjust ignition breaker point gap to .020 inch (0.51 mm) at full separation.
4. Turn flywheel to left, against crankshaft rotation, until mark is about two inches past 25° mark on gear cover.
5. Turn flywheel slowly to right and note whether ignition points just separate when mark on flywheel aligns with 22° mark on gear cover (engine must be on the compression stroke).
 - a. If marks align as the points break, timing is correct.
 - b. If not, loosen breaker box mounting screws and shift breaker box assembly slightly upward to retard the timing (points breaking too

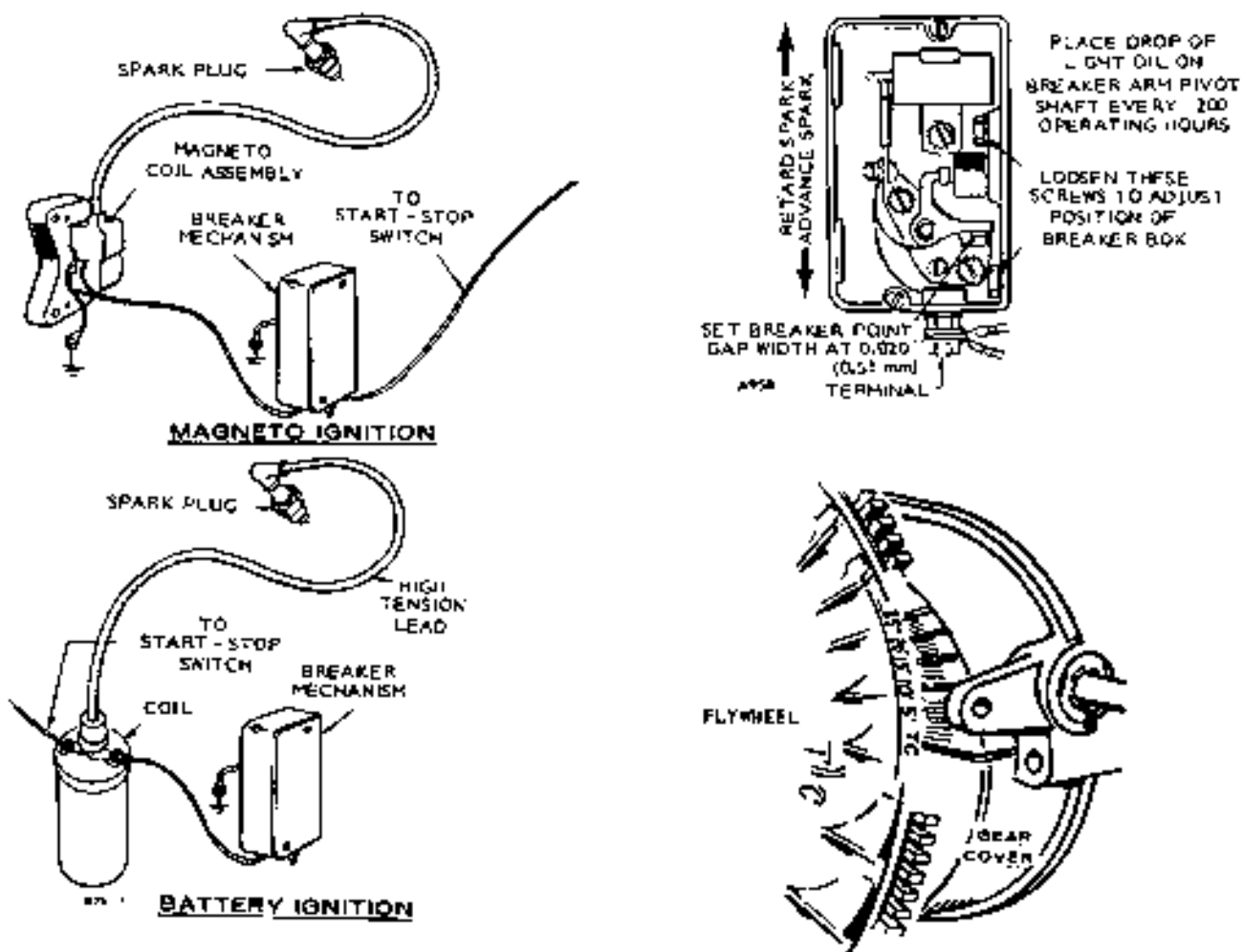

FIGURE 10-30. NB IGNITION SYSTEMS

REV. 11-78

soon), or slightly downward to advance the timing (points not breaking soon enough).

- c. Tighten breaker box mounting screws securely after making an adjustment.
6. To accurately check the timing at which spark occurs, engine not running.
 - a. Connect a continuity tester across the ignition breaker points.
 - b. Touch one test prod to the breaker box terminal (to which the lead to the coil is connected) and touch the other test prod to a good ground on the engine.
 - c. Turn crankshaft against rotation (backwards) until points close.
 - d. Then slowly turn crankshaft with rotation.
 - e. The lamp should go out just as points break open.
7. Reinstall breaker box cover.

NB—BREAKERLESS IGNITION

The NB engine is equipped with a flywheel mounted alternator which supplies voltage to both the ignition and battery charging circuits. The ignition system is a breakerless type. The battery charging circuit supplies about 10 amps maximum and 2 amps minimum battery charge rate.

IGNITION TIMING

The breakerless ignition is factory-set and should normally require no adjustment. However, if through accident or misuse, the ignition system gets out of adjustment, readjust as follows:

1. The outer rim of the flywheel has a dowel pin protruding about 3/16" from the surface. See Figure 10-31. When this pin passes below the breaker module assembly, the spark is discharged to the spark plug, thus firing the fuel mixture in the combustion chamber.
2. For proper ignition, the gap between this pin and the breaker module pin should be .008 inch (0.203 mm) when measured with a feeler gage.
3. To adjust, loosen mounting bolts A and tap the assembly lightly, up or down as need be, until proper gap is attained.
4. Tighten bolts A and recheck gap for accuracy.
5. The timing advance is preset at the factory and cannot be changed.

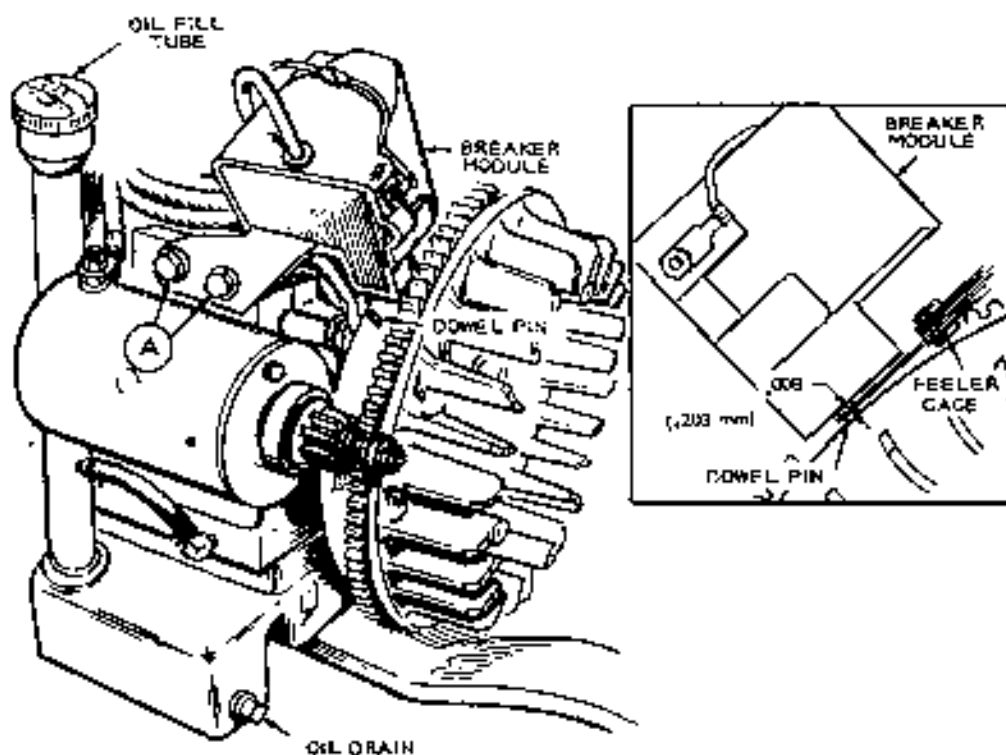

FIGURE 10-31. BREAKER PIN GAP ADJUSTMENT

NHA, NHB, ENGINES AND NH POWER DRAWER SETS

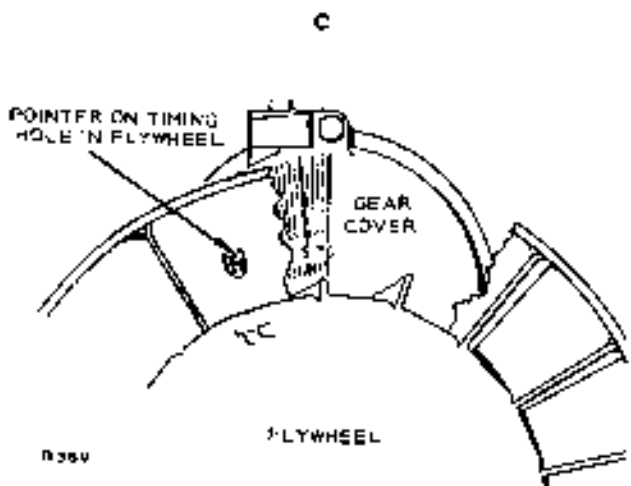
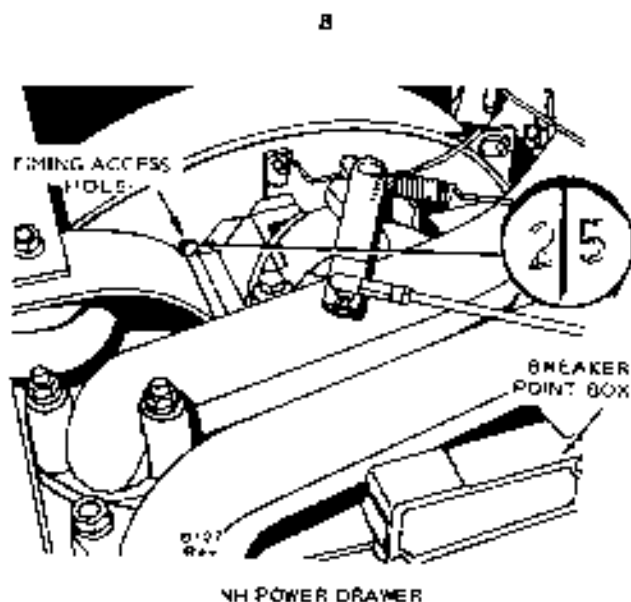
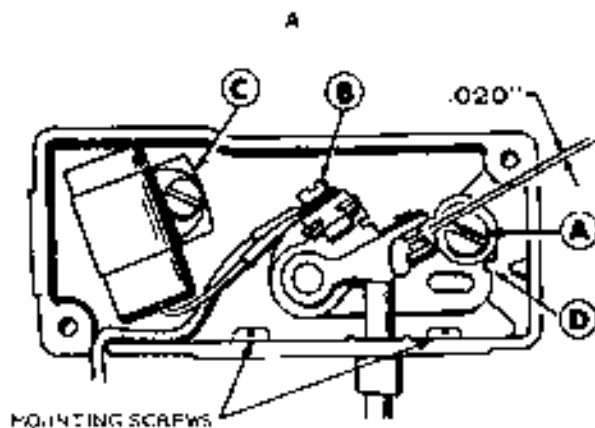

FIGURE 10-32. NHA, NHB, AND NH TIMING

SIDE ADJUST BREAKER POINTS

To maintain maximum efficiency from the engine, change the breaker points every 200 hours of operation. Proceed as follows when the engine is cold.

1. Remove two screws and cover on breaker box.
2. Remove spark plugs so crankshaft can be easily rotated by hand. If plugs have not been changed within last 200 hours, replace them with new plugs after setting breaker points.
3. Refer to Figure 10-32A. Remove mounting screw (A) and pull points out of box just far enough so screw (B) can be removed and leads disconnected.
4. Remove screw (C) and replace condenser with a new one.
5. Replace points with a new set but do not completely tighten mounting screw (A).
6. On NH Power Drawer units, a small hole on rear of blower housing provides access to view timing mark (Figure 10-32B).
7. Rotate engine by hand until 25° BTC mark on gear aligns with mark on flywheel. Turn another 1/4 turn (90°) to ensure points are fully open.
8. Using a screwdriver inserted in notch (D) on right side of points, move points until gap measures .020 inch with a flat thickness gauge. Tighten mounting screw and recheck gap. Timing is automatically set at 25° BTC when point gap is .020 inch (0.51 mm).
9. Check ignition timing.

IGNITION TIMING

The engine timing is preset at the factory. A non-movable breaker point box is used, however a slight timing change could be made by adjusting points. The engine is equipped with a battery ignition system. Spark advance is set at 25° BTC (before top center), and should be maintained for best engine performance. Always check timing after replacing ignition points or if poor engine performance is noticed. Proceed as follows:

Timing — Engine Running:

1. To accurately check ignition timing, use a timing light with engine running at idle speed. Connect the timing light according to its manufacturer's instructions. Either spark plug can be used as they fire simultaneously.
2. Start engine and check timing. Timing pointer on flywheel should line up with 25° mark on cover. The timing hole through the flywheel and the timing marks on the timing gear cover can be seen by looking through the flywheel blower screen, see Figure 10-32C.

Timing — Engine Not Running

If a timing light is not available, check the timing as follows:

1. Connect a continuity tester across ignition breaker points. Touch one test prod to breaker box terminal to which coil lead is connected and

- touch other test prod to a good ground on engine.
2. Turn crankshaft against rotation (counterclockwise) until points close. Then slowly turn crankshaft with rotation (clockwise).
3. The lamp should go out just as points open which is the time at which ignition occurs (25° BTC).

NHP-NHPV ENGINES

GENERAL

The engine is equipped with an automotive type battery ignition system. Both spark plugs fire simultaneously, thus the need for a distributor is eliminated. Spark advance is set at 25° BTC (before top center), and should be maintained for best engine performance. Always check timing after replacing ignition points or when poor engine performance is noticed.

TOP ADJUST BREAKER POINTS — TIMING

To maintain maximum engine efficiency, replace the breaker points every 100 hours of operation. Proceed as follows:

1. Remove spark plugs and rotate flywheel TC mark to 25° BTC (points open); then rotate it another 90 degrees clockwise to ensure points open fully.
2. Remove breaker box cover and unplug coil wire at coil (+) terminal.
3. Remove condenser (screw A) and detach condenser lead and coil lead (screw B), Figure 10-33.

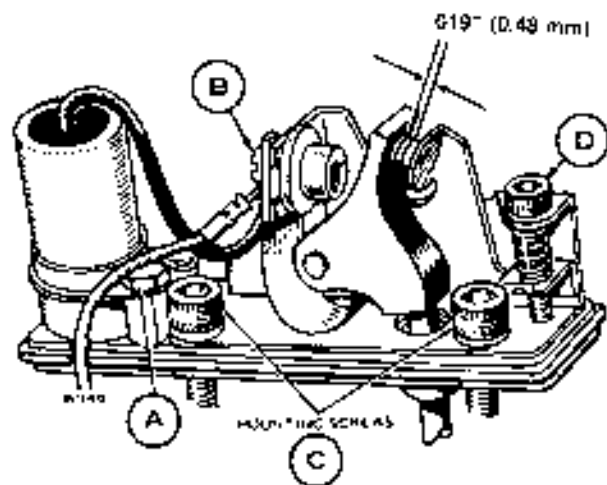

FIGURE 10-33. BREAKER POINT ADJUSTMENT

4. Remove two Allen screws (C) and lift breaker assembly from engine.
5. Replace condenser and point assembly with new parts and reinstall using above procedure in reverse order of removal.
6. Using Allen wrench at screw (D) adjust point gap at .019 inch (0.48 mm) using a clean, flat thickness gauge.

Setting point gap accurately adjusts engine timing.

7. Replace breaker box cover and spark plugs.

If desirable, check ignition timing with a 12 volt test light or continuity tester.

TIMING CHECK—PRESSURE COOLED ENGINE-NHP

The timing on the engine is preset at the factory. A non-movable breaker point box is used, however a slight timing change could be made by adjusting points.

Engine Running:

1. To accurately check ignition timing, use a timing light with engine running at idle speed. Connect timing light according to its manufacturer's instructions. Either spark plug can be used as they fire simultaneously.
2. Start engine and check timing. Timing pointer on flywheel should line up with 25° mark on cover. The timing hole through the flywheel and the timing marks on the timing gear cover can be seen by looking through the flywheel blower screen. See Figure 10-34.

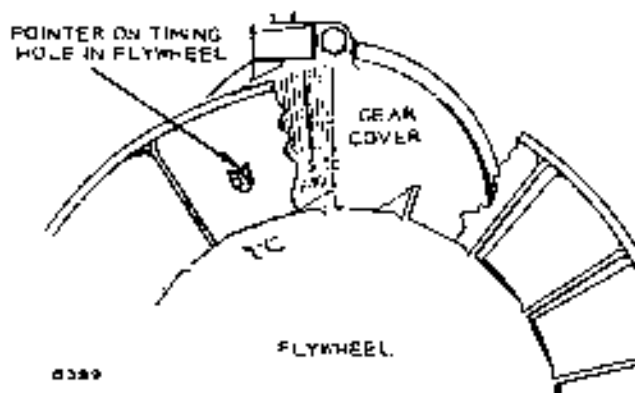

FIGURE 10-34. NHP FLYWHEEL TIMING HOLE

Engine Not Running: If a timing light is not available, check the timing as follows:

1. Connect a continuity tester across the ignition breaker points. Touch one test prod to the breaker box terminal to which coil lead is connected and touch the other test prod to a good ground on engine.
2. Turn crankshaft against rotation (counterclockwise) until points close. Then slowly turn crankshaft with rotation (clockwise).
3. The lamp should go out just as points open which is the time at which ignition occurs (25° BTC).

TIMING CHECK—VACU-FLO ENGINE-NHPV

Engine timing is advanced or retarded by opening or closing the breaker point gap. Setting the point gap at 0.019 inch (0.48 mm) is the most accurate method of timing the engine.

Dynamic timing (engine running) may be less accurate because the sight angle from the viewer to the flywheel scribe mark and timing pointer may vary $\pm 2^\circ$ from 25° BTC, Figure 10-35.

The timing pointer is mounted on the cylinder block above the oil filter; it is made accessible by removing the right hand shroud.

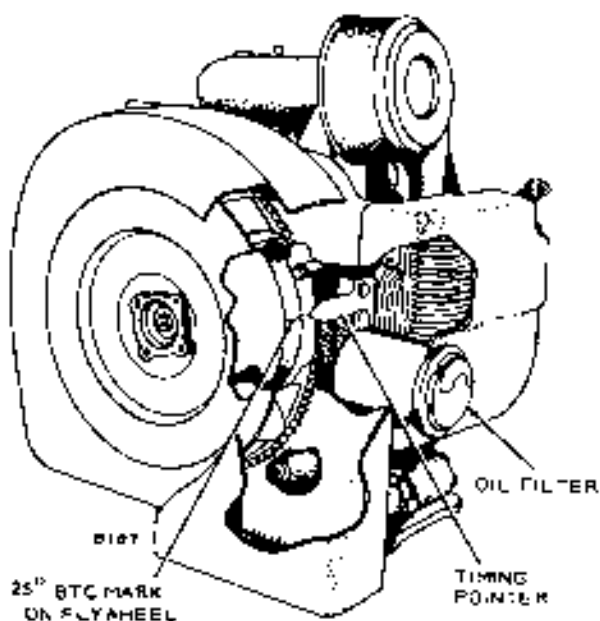

FIGURE 10-35. NHPV VACU-FLO ENGINE — TIMING MARK AND POINTER

NHC-NHCV ENGINE SERIES

GENERAL

The NHC and NHCV engines use battery ignition system. Both spark plugs fire simultaneously so a distributor is not required. Spark advance is set at 20° BTC (before top center), and should be maintained for best engine performance. Always check timing after replacing ignition points or when poor engine performance is noticed.

TIMING CHECK—PRESSURE COOLED ENGINE

The timing on the engine is preset at the factory. A non-movable breaker point box is used, however a slight timing change could be made by adjusting points.

Engine Running

1. To accurately check ignition timing, use a timing light with engine running at idle speed. Connect timing light according to its manufacturer's instructions. Either spark plug can be used as they fire simultaneously.
2. Start engine and check timing. Timing pointer on flywheel should line up with 20° mark on cover. The timing hole through the flywheel and the timing marks on the timing gear cover can be seen by looking through the flywheel blower screen. See Figure 10-36.

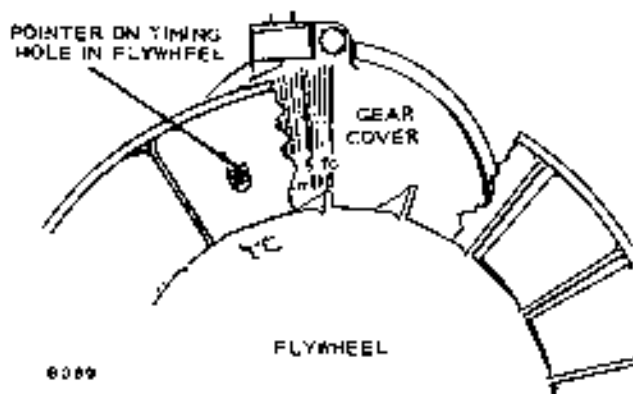

FIGURE 10-36. NHC FLYWHEEL TIMING HOLE

Engine Not Running

If a timing light is not available, check the timing as follows:

1. Connect a continuity tester across the ignition breaker points. Touch one test prod to breaker box terminal to which coil lead is connected and touch other test prod to a good ground on engine.
2. Turn crankshaft against rotation (counterclockwise) until points close. Then slowly turn crankshaft with rotation (clockwise).
3. The lamp should go out just as the points open which is the time at which ignition occurs (20° BTC).

TIMING CHECK VACU-FLO ENGINE

Engine timing is advanced or retarded by opening or closing the breaker point gap. Setting the point gap at 0.016 inch (0.41 mm) is the most accurate method of timing the engine.

Dynamic timing (engine running) may be less accurate because the sight angle from the viewer to the flywheel scribe mark and timing pointer may vary ± 2 from 20° BTC. Figure 10-37.

The timing pointer is mounted on the cylinder block above the oil filter; it is made accessible by removing the right hand shroud.

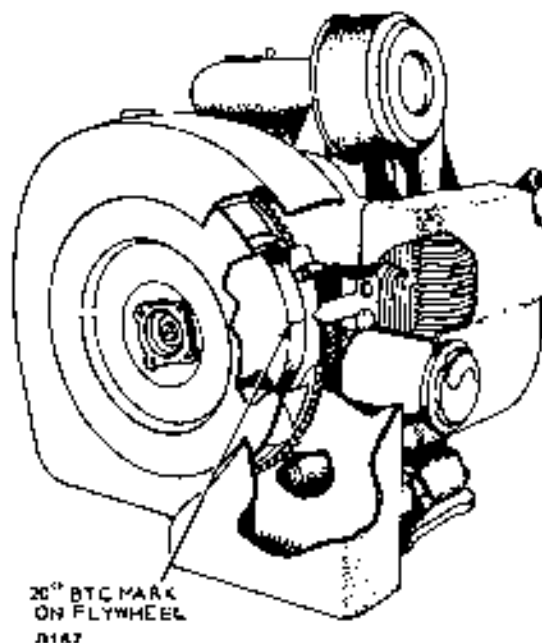

FIGURE 10-37. NHCV VACU-FLO ENGINE — TIMING MARK AND POINTER

TOP ADJUST BREAKER POINTS—TIMING

To maintain maximum engine efficiency, check the breaker points every 100 hours of operation and replace if necessary. Proceed as follows:

1. Remove spark plugs and rotate flywheel TC mark to 20° BTC (points open); then rotate it another 90 degrees clockwise to ensure points open fully.
2. Remove breaker box cover and unplug coil wire at coil (+) terminal.
3. Remove condenser (screw A) and detach condenser lead and coil lead (screw B), Figure 10-38.
4. Remove two Allen screws (C) and lift breaker assembly from engine.
5. Replace condenser and point assembly with new parts and reinstall using above procedure in reverse order of removal.
6. Using Allen wrench at screw (D) adjust point gap at .016 inch (0.41 mm) using a clean, flat thickness gauge.

Setting point gap accurately adjusts engine timing.

If desirable, check ignition timing with a 12 volt test light or continuity tester.

4. Replace breaker box cover and spark plugs.

CAUTION

This engine uses a 12 volt, negative ground system. Alternator must be connected to battery at all times when engine is running. Do not reverse battery cables.

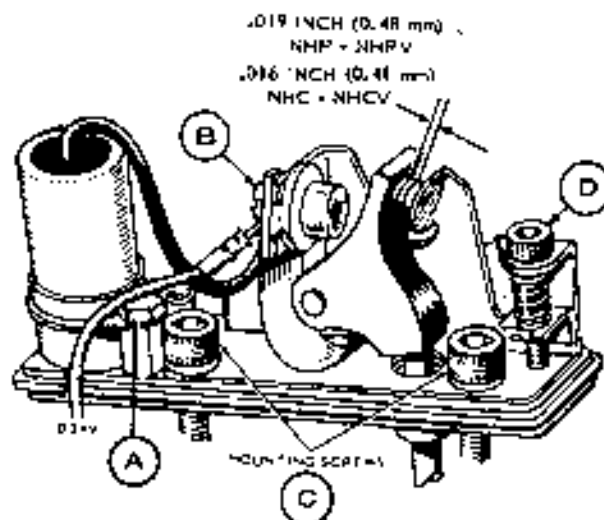

FIGURE 10-38. BREAKER POINT ADJUSTMENT

IGNITION EQUIPMENT

The *battery ignition* system timing procedures herein are for the standard pressure cooled and the optional or mobile Vacu-Flo cooled engine-generator sets. The timing point for all battery ignition models is at 22° before top center (BTC).

The *magneto ignition* system timing procedures herein are for the contractors model generator sets with the electric starter and an automatic spark advance mechanism. The timing point for magneto ignition models is 3° after top center (ATC) with the engine stopped and 22° BTC with the engine running at over 1500 rpm.

The breaker point removal and gapping procedure is the same for both the battery and the magneto ignition systems.

SIDE ADJUST BREAKER POINTS

Replace burned or faulty points. If only slightly burned, dress smooth with file or line stone. Measure gap with thickness gauge. Set point gap at .020 inch (0.51 mm).

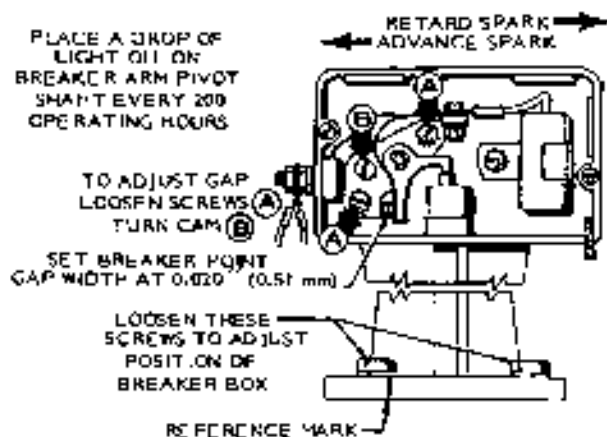

FIGURE 10-39. BREAKER POINTS

Breaker Point Removal and Gapping:

1. Remove breaker box cover, Figure 10-39.
2. Remove spark plugs so crankshaft is easily rotated by hand
3. Remove breaker point mounting screws and replace points with a new set. Do not completely tighten breaker point mounting screws at this time.

4. Rotate crankshaft clockwise by hand until TC mark on flywheel and TC mark (or correct degree mark) on gear cover align, Figure 10-40.
5. Turn point adjusting cam screw (B) until point gap is .020 inch (0.51 mm) and tighten mounting screws (A) as shown in Figure 10-39
6. Turn flywheel to left past timing marks. Now turn to right. Points should open when flywheel TC mark aligns with correct degree mark. If not, it is necessary to set the ignition timing.
7. Replace spark plugs.

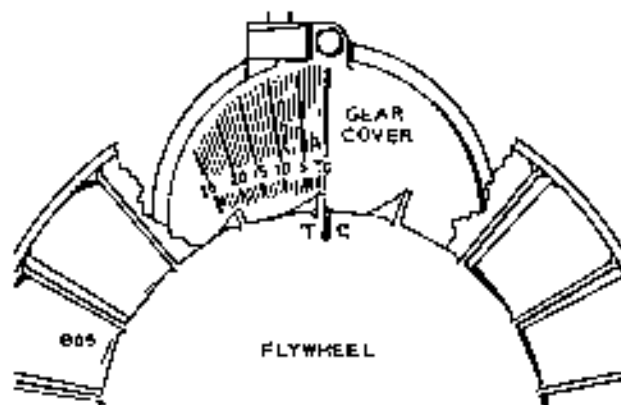

FIGURE 10-40. TIMING (PRESSURE COOLED)

TIMING—BATTERY IGNITION

The pressure cooled engine timing mark is observed by looking through the flywheel fan to the timing marks on the gear cover, Figure 10-40. Engine timing is set at 22° BTC (before top center) and should be maintained for best engine performance. Always check timing after replacing ignition points or if poor engine performance is noticed. Proceed as follows:

Mobile and other Vacu-Flo equipped engine timing marks are observed through a plugged hole in the engine shroud, Figure 10-41.

Timing — Engine Not Running

1. Connect a continuity tester across ignition breaker points. Touch one test prod to breaker box terminal to which coil lead is connected and touch other test prod to a good ground on engine.
2. Turn crankshaft against rotation (counterclockwise) until points close. Then slowly turn crankshaft clockwise.
3. Lamp should go out just as points open which is time at which ignition occurs (22° BTC).

Timing — Engine Running

1. To accurately check ignition timing, use a timing light when engine is running. Connect timing light according to its manufacturer's instructions. Either spark plug can be used as they fire simultaneously.
2. Observe timing mark through flywheel fan. On Vacu-Flo engines, remove dot button from timing hole, Figure 10-41.
3. Start engine and check timing. Mark on flywheel should line up with 22° BTC mark on cover.
4. If timing needs adjustment, loosen mounting screws on breaker box and move left to advance or right to retard timing.
5. Start engine to be sure mark on flywheel lines up with 22° mark on cover.
6. Tighten all screws, replace timing plug.

TIMING—MAGNETO IGNITION

The contractor's model NH Generator Set is equipped with electric start and magneto ignition. The magneto stator assembly is mounted on the gear cover and the flywheel must be removed to expose the magneto.

Spark Advance Mechanism (Contractor Model Only). The spark advance mechanism (Figure 10-42) is located on the rear of the camshaft. It is operated by centrifugal force. As the engine speeds up, the weights rotate the cam and advance the spark. The cam returns to the retarded position as the engine speed is decreased. If the mechanism should become

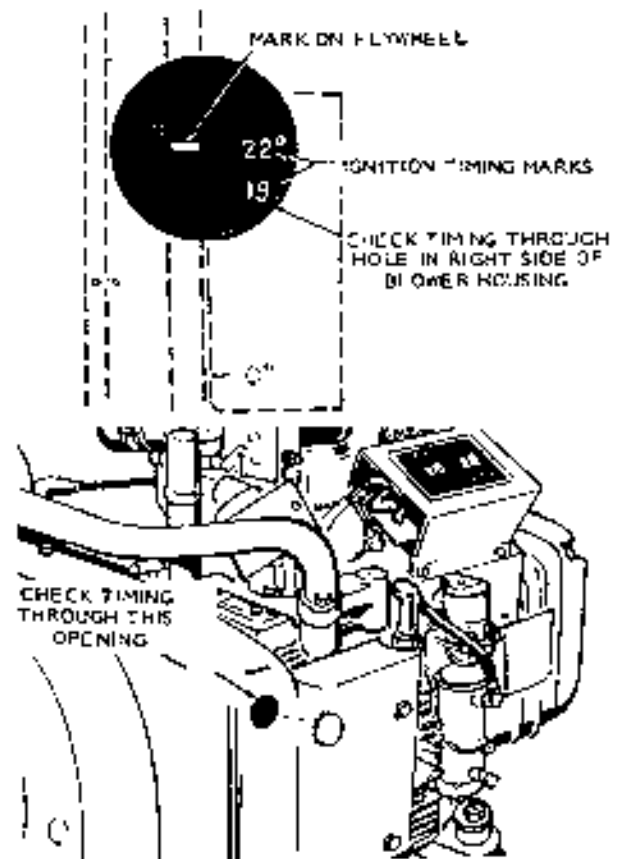

FIGURE 10-41. TIMING ACCESS HOLE (VACU-FLO)

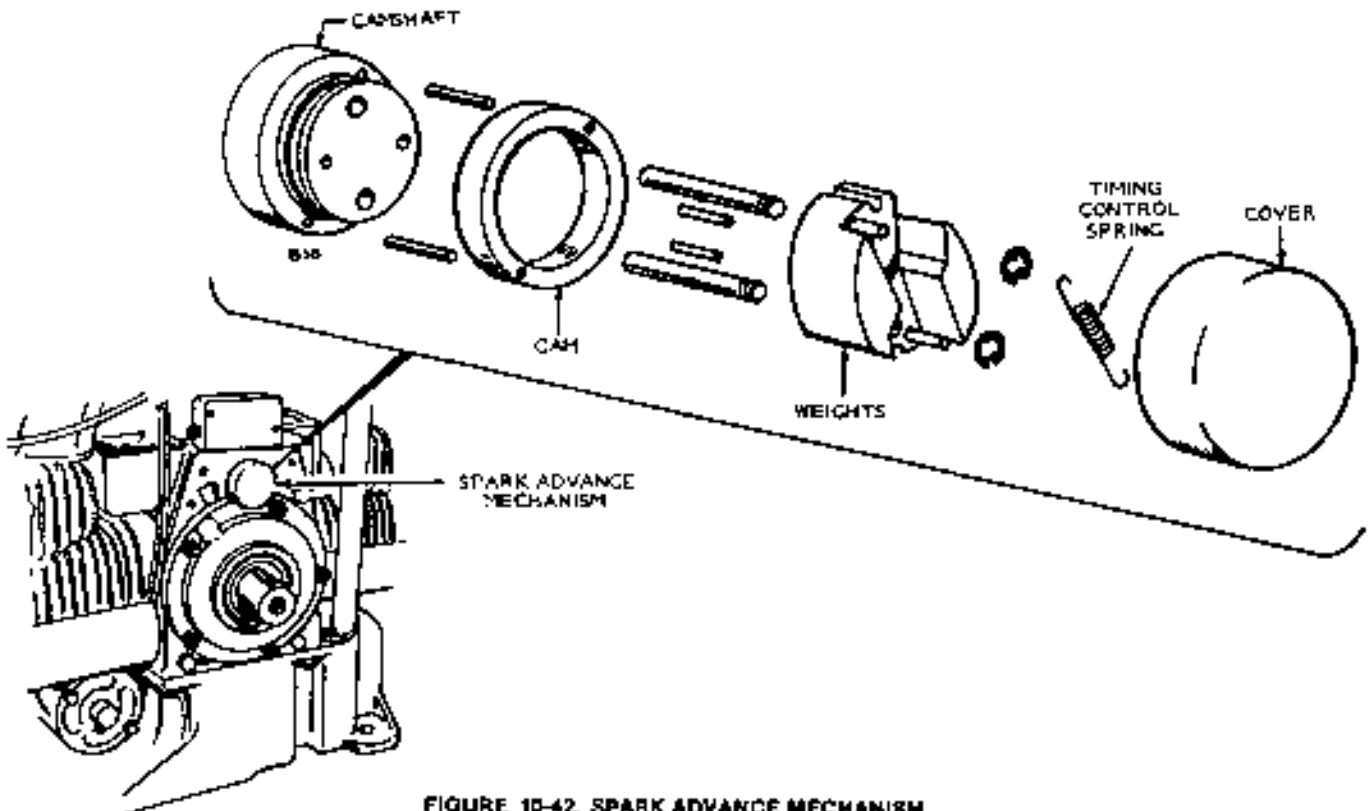

FIGURE 10-42. SPARK ADVANCE MECHANISM

REV. 11-78

dirty or gummy, it would remain closed (retarded), causing the engine to lose power. If the mechanism remains open (advanced), the engine would possibly kick back on cranking. The cam advance must be snap acting. Should the engine fail to pick up speed or tend to alternately increase and decrease speed, the mechanism may require cleaning.

The spark advance mechanism can be reached for cleaning by either removing the cup shaped cover in the crankcase rear camshaft opening to expose the mechanism or by removing the camshaft from the engine. Do not dent the cup shaped cover as it will interfere with the weight mechanism.

Checking Spark Advance Mechanism

1. The timing marks are visible through flywheel.
2. Connect timing light to spark plug.
3. Start engine and run at 3600 rpm.
4. View timing marks using a timing light. The TC mark on flywheel should align with TC mark on gear cover.
5. While watching timing marks with timing light, slow engine to below 800 rpm. If TC mark on flywheel disappears and then reappears when engine speed is increased, the mechanism is operated properly.
6. If spark advance mechanism does not react as described in step 5, remove, clean and/or replace as necessary.
7. Replace cover.

Timing — Engine Running

1. Install an automotive timing light on either spark plug lead.
2. Run engine at rated speed and check timing with light. If timing is incorrect, loosen breaker plate mounting screws and correct it by moving plate. Moving plate left advances timing, moving it right retards timing. Spark advance with engine running at 1800 rpm is 22° BTC. Tighten plate and recheck timing point.
3. Readjust timing if necessary, tighten breaker plate and then recheck ignition point gap.

Timing — Engine Not Running

1. Remove breaker box cover. If ignition timing is off, attain approximate setting (see *Breaker Points*). Install a continuity tester across breaker points so lamp lights when points are closed.
2. Rotate flywheel clockwise until TC mark on flywheel approaches timing pointer (Figure 10-41). Then slowly rotate flywheel clockwise until light goes out, indicating that points have opened at ignition point. If timing is correct, ignition occurs at 3° ATC.
3. If ignition timing isn't correct, align 3° ATC mark and timing pointer; then loosen breaker plate capscrews and rotate plate so light goes out. Rotating clockwise advances timing, counterclockwise retards it.
4. Tighten plate and recheck timing (Step 2). If timing is not correct, readjust plate.

GENERAL

Three different types of ignition systems cover the manual- and electric-starting models on two- and four-cylinder engines. The manual-starting two-cylinder model (JB-M) uses a magneto system. The two-cylinder remote and electric-starting engines (JB-R, JB-E) use a battery ignition system. The four-cylinder model (JC) uses a battery ignition system with an automotive distributor. Specially suppressed systems with two coils and two sets of breaker points are used on the MJC and some JC electric generating sets.

TESTING

Remove each plug, install the ignition wire to each plug and hold the plug base against bare engine metal. Crank the engine and watch the spark. A good blue spark indicates a healthy ignition system, a weak or yellow spark or no spark indicates a poor ignition system. Defective ignition can be caused by defective breaker points, coil condenser, or wiring. A good spark on all but one cylinder indicates a defective spark plug or a defective high tension wire.

BATTERY IGNITION (JB Electric and Remote Start Engines)

The JB engines (Figure 10-43) use a twin coil to fire both spark plugs simultaneously. One spark plug fires on the exhaust stroke while the other fires at the top of the compression stroke. A spark advance on the breaker point mechanism advances the spark from 5° ATC (after top center) at cranking speed, to 25° BTC (before top center) when running at rated speed, Figure 10-44.

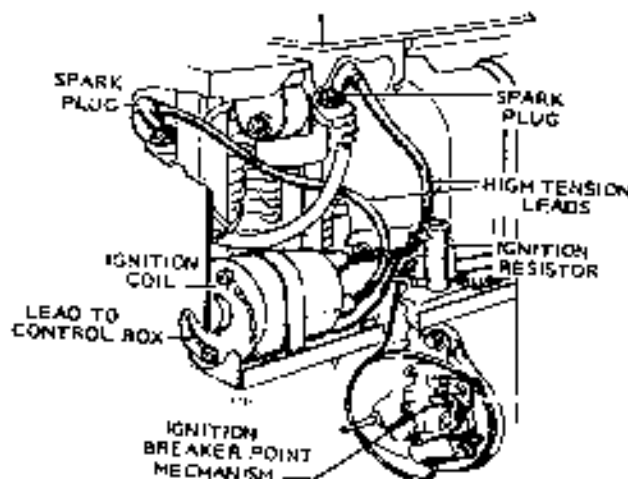

FIGURE 10-43. BATTERY IGNITION SYSTEM

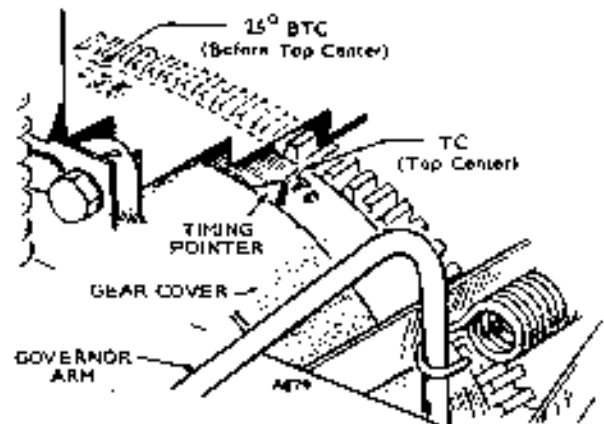

FIGURE 10-44. JB-JC TIMING MARK

Maintenance

Periodic maintenance should include:

- Checking ignition breaker point gap.
- Checking and cleaning spark plugs.
- Inspecting both low and hi-tension wiring.
- Checking ignition timing.

The JB engine with a flywheel magneto must always fire at 25° BTC, regardless of type of fuel. The JB engines have an automatic advance of 30°; the JC engines 26°.

Check the point gap with a .020 inch (0.51 mm) feeler gauge. Adjust gap by loosening the adjustment screw and moving the stationary contact. Tighten screw and check gap, Figure 10-45. Check points for cleanliness and pitting. Clean points with paper or gauze tape. If they are defective or excessively pitted, replace them.

Some early engines had no 5° ATC mark on the flywheel. On these models, open the breaker box and rotate the flywheel until the breaker points open to maximum gap.

Adjust the breaker point gap before timing the ignition.

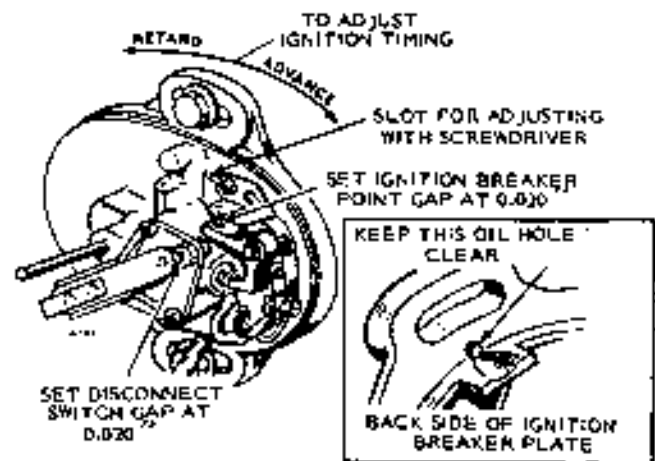

FIGURE 10-45. TIMING IGNITION WITH ENGINE STOPPED

Timing — Engine Not Running

1. Remove access door in air housing. Remove breaker point cover. Disconnect lead to ignition points and install a continuity tester and battery so lamp lights when points are closed.
2. Rotate flywheel clockwise until TC mark on flywheel approaches timing pointer, Figure 10-44. Then slowly rotate flywheel clockwise until light goes out, indicating that points have opened. This is the ignition point. If timing is correct, ignition occurs at 5° ATC.
3. If ignition timing isn't correct, align 5° ATC mark and timing pointer, then loosen breaker plate capscrews and rotate plate until light goes out. Clockwise rotation advances timing, counterclockwise rotation retards it, Figure 10-45.
4. Tighten plate and check timing, step 2. If timing isn't correct, readjust plate. If correct, connect ignition lead and install cover.

Timing — Engine Running

CAUTION Do not run the engine for more than a minute or two with access door open or removed. The engine overheats rapidly and can damage itself. Run without load.

1. Remove access door and install an automotive timing light on either of spark plug leads.
2. Run engine at rated speed and check timing with light. If timing is incorrect, loosen breaker plate mounting screw and correct it by rotating plate. Rotating clockwise advances timing; turning counterclockwise retards it. Tighten plate and recheck timing point.
3. Adjust timing at 25° BTC, tighten breaker plate and then recheck ignition point gap.

If the breaker points can't be adjusted to specifications, either the timing gear or camshaft gear is incorrectly installed, or the centrifugal advance mechanism is defective. Disassemble the breaker mechanism for repair.

BREAKER POINT MECHANISM

The breaker points operate from a cam located on the timing or start-disconnect gear. This gear is driven by the camshaft gear.

Disassembly:

1. Disconnect battery to prevent accidental shorts.
2. Remove breaker point cover and disconnect wires from start-disconnect switch (if used) and ignition breaker points.
3. Remove two capscrews holding breaker plate assembly and pull off plate.
4. Pull out cam and weight assembly. Be careful not to lose spacer mounted on gear shaft.

5. To disassemble breaker plate assembly, remove condenser and points and pull out plunger and plunger diaphragm.

Repair: Thoroughly clean the gear and cam assembly. The weights should move freely in and out without catching in either end position. Inspect the gear ramp for notches or other defects. If any part of the cam weight and gear assembly sticks, replace the complete assembly. Inspect the weight springs and compare them with Figure 10-46. If the cam is loose on the gear replace the complete assembly. Clean and inspect the bearing surfaces in the breaker plate and gear case. Clean the oil trickle holes into these bearings. Check the oil spray hole in the gear case to be sure it is open. If the breaker points won't maintain the proper gap, check for excess wear in both the cam and the ignition breaker plunger.

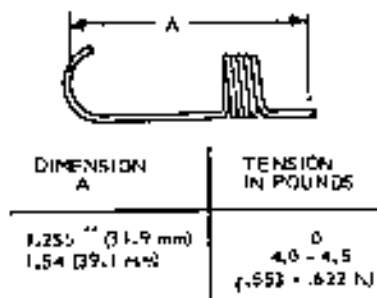

FIGURE 10-46. WEIGHT SPRING SPECIFICATIONS

Assembly:

1. Install springs on weight assemblies. Install cam on gear shaft, being sure to align timing marks, Figure 10-47, and install cam spring. Weights should snap outward between 1000 and 1075 rpm. If necessary, adjust by lightly bending one or both spring anchor pins toward center of gear.
2. Install spacer and thrust washer on gear shaft assembly and install assembly into gearcase, matching timing marks on timing gear and camshaft gear.
3. Install spring and plunger on end of shaft.
4. Install breaker plate. Install ignition plunger and diaphragm and diagram cup, Figure 10-48.
5. Install start-disconnect diaphragm (when used), and plunger, and install start-disconnect breaker points.
6. Adjust start-disconnect breaker point gap to .020 inch (0.51 mm).
7. Install ignition breaker points and adjust gap.
8. Time ignition.

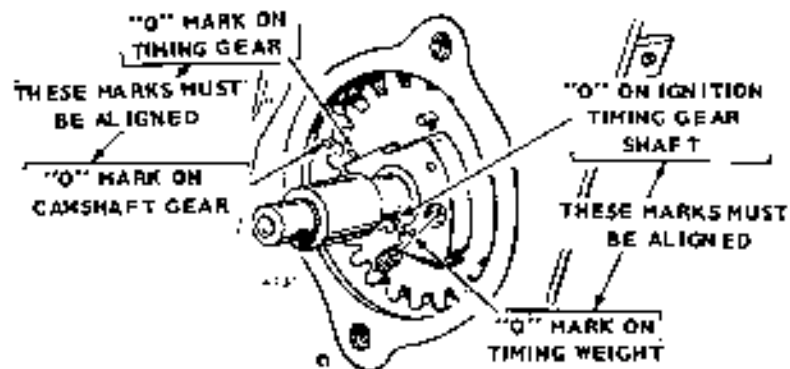
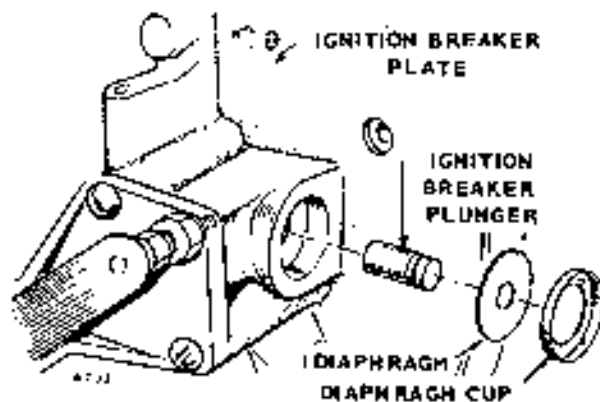

FIGURE 10-47. ALIGNING TIMING MARKS



Test this coil using a six-volt tester only.

MAGNETO IGNITION (JB, Manual Start Engines)

This ignition system is similar to the JB battery ignition except that it uses a magneto as a source of power. The magneto is behind the flywheel and consists of both stator and secondary windings, energized by permanent magnets on the flywheel. Figure 10-49 shows the magneto ignition system.

Maintenance, timing, condenser repair, and breaker repair are the same as for Battery Ignition on JB electric start engines.

FIGURE 10-48. BREAKER PLATE ASSEMBLY

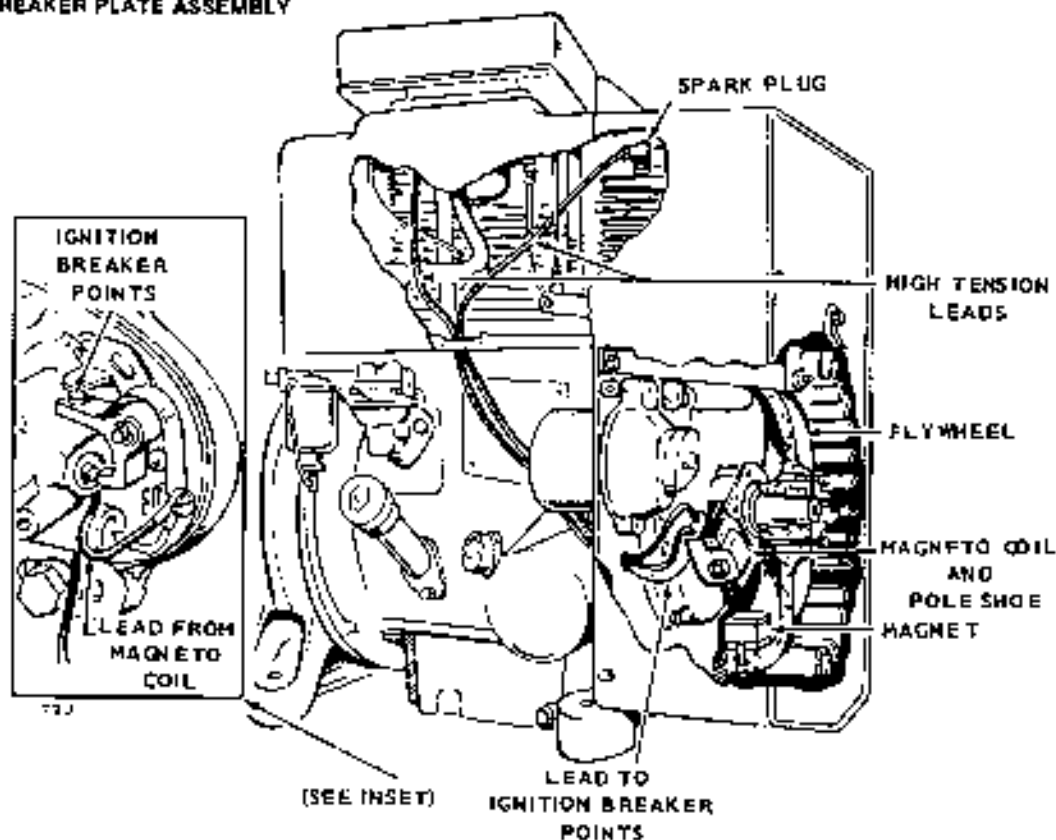

FIGURE 10-49. MAGNETO IGNITION SYSTEM (JB ENGINES)

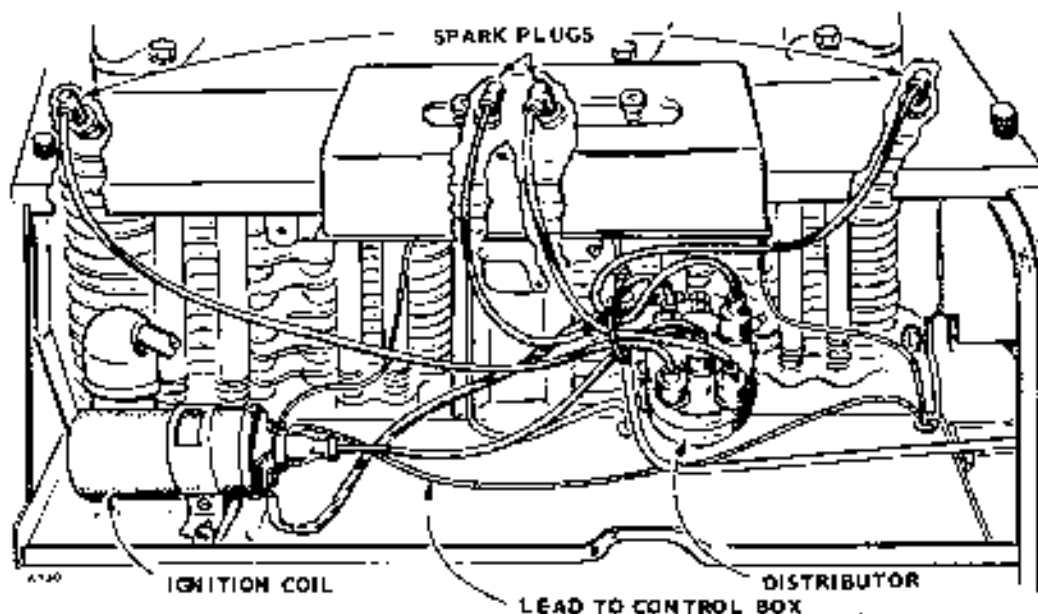

FIGURE 10-50. BATTERY IGNITION SYSTEM WITH AUTOMOTIVE DISTRIBUTOR (JC, RJC)

Magneto Coil

The magneto coil is reached by removing the flywheel. If the spark at the spark plugs is defective, first inspect the breaker points. To test the coil, remove both spark plug leads; ground one to engine. Hold the other about 3/8 inch away from bare metal and crank the engine. A good spark should occur between the lead and engine. If not, the coil, flywheel magnets, or high tension leads are defective. Test the coil as follows:

1. With an ohmmeter, check resistance between breaker point lead (disconnected from the points) and a good ground on the engine. Resistance should be about 0.6 ohms.
2. Remove both spark plug leads from plugs and measure coil resistance between leads: resistance should be about 11,000 ohms. If it is greater, either the leads or magneto high tension coils contain a high resistance or are open-circuited. The magneto should be removed to test resistances of the coil and leads separately. Inspect the high tension terminals on the coil for corrosion. If the resistance is low, the secondary winding is probably shorted and the coil must be replaced.
3. Check for shorting between primary and secondary circuits by measuring resistance from breaker lead to a spark plug lead. Any continuity indicates a defective coil.

The system includes an ignition coil, a distributor with spark advance, a condenser, single (or dual) breaker points, and spark plugs, Figure 10-51.

The primary or low voltage circuit includes the battery ignition switch, breaker points, primary winding of the ignition coil and condenser. The secondary or high voltage circuit includes the secondary winding of the coil, distributor rotor and cap, high tension wiring, and spark plugs.

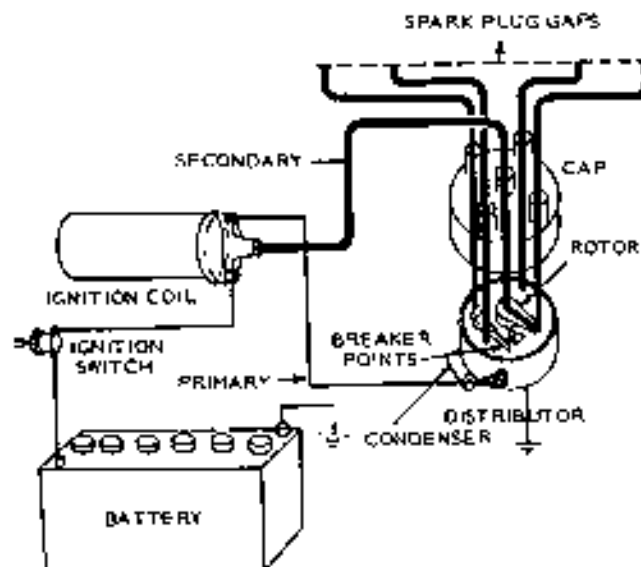

FIGURE 10-51. PRIMARY AND SECONDARY CIRCUITS

BATTERY IGNITION — JC, MJC, RJC ENGINES

The JC engines use a battery ignition system with an automotive distributor to produce and distribute spark, Figure 10-50.

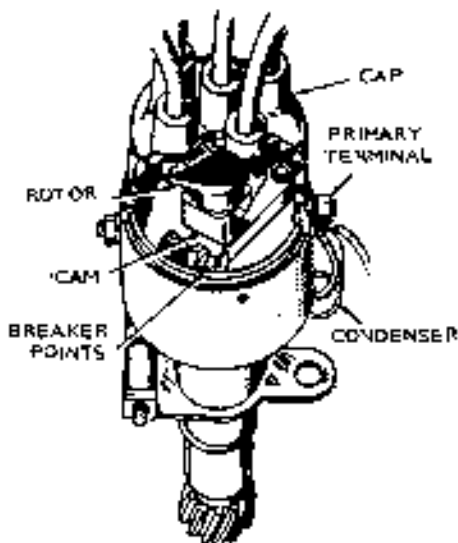

FIGURE 10-52. FOUR CYLINDER - DISTRIBUTOR - (SINGLE POINT SET)

DISTRIBUTOR

The ignition distributor (Figure 10-52) contains breaker points which open and close to cause a magnetic buildup and collapse in the ignition coil. This produces high voltage impulses in the coil secondary winding which are led through the distributor cap and rotor to the proper spark plug lead. The ignition points are actuated by a rotating cam which is gear driven off the engine camshaft.

When engine speed increases, the spark must be introduced into each cylinder so the fuel and air mixture can be ignited with enough time to burn, and deliver full power to the piston. On the four cylinder, J-series engines, a centrifugal advance mechanism is built into the distributor. Centrifugal advance weights throw out against spring tension as engine speed and distributor rotor speed increase. This causes a change in the position of the cam in relation to the distributor, opening the breaker points earlier in respect to the upward moving piston.

Maintenance

Periodic maintenance of the system should include oiling the distributor, cleaning and adjusting the breaker points, checking ignition timing, cleaning and adjusting the spark plugs, and inspecting the ignition system wiring.

At regular intervals, add 3 to 5 drops of medium engine oil to the oiler on the distributor. Add 1 drop of light engine oil to the breaker arm hinge pin and 3 to 5 drops to the felt in the top of the breaker cam and to the governor weight pivots. Wipe grease lightly on each lobe of the breaker arm. Don't over-lubricate the distributor.

BREAKER POINTS ADJUSTMENT

To adjust the breaker points, remove the distributor cap and rotor. Rotate the crankshaft to get maximum breaker gap. The gap should be between .018 inch and .022 inch (0.46 to 0.56 mm). At the same time, inspect the points for dirt or pitting. Dirty points can be cleaned with tape and solvent. If the points are pitted, they must be replaced. See Figure 10-53.

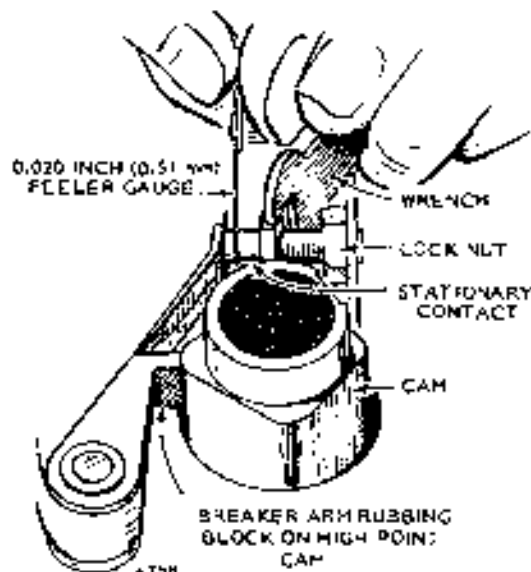

FIGURE 10-53. SETTING SINGLE BREAKER POINTS

Dual ignition points are adjusted in the same way. Adjust the point gap for each set to open .018 to .022 inch (0.46 to 0.56 mm) on high point of cam.

Check the distributor cap for cracks, carbon runners, corroded high tension terminals or excessively-burned rotor contacts.

Timing — Single Points Ignition

The single points ignition system may be timed either with the engine stopped or running. Before timing the ignition, be sure the breaker points are clean and properly adjusted. Set the timing at 25° BTC (running) of each compression stroke (35° BTC for gaseous fuel or combination gasoline-gaseous fuels).

Engine Stopped:

1. Disconnect low voltage lead to distributor and connect a test lamp and battery so lamp lights when breaker points are closed.
2. Remove spark plug from #1 cylinder and rotate flywheel clockwise until air is forced out of spark plug hole.
3. Observe timing pointer through upper dot button hole and continue rotating flywheel slowly until test lamp goes out, indicating that breaker points

have opened. If TC mark on flywheel and ignition timing pointer on gear cover are aligned, timing is correct.

- To adjust timing, align flywheel TC mark and timing pointer. Loosen distributor body and rotate it (clockwise if ignition occurred early and counterclockwise if late), until light goes out. Tighten distributor body in new position and check timing, step 3. If timing still does not occur at correct point, repeat step 4.

Engine Running:

- Remove access door and install an automotive timing light on spark plug for cylinder #1. Run engine at rated speed. Aim flashing timing light in through access door opening and toward flywheel. Remove upper dot button to view timing mark and pointer.

CAUTION Do not run the engine for more than a minute or two with the access door open or removed. The engine overheats rapidly and can damage itself. Run without load.

- The timing pointer on gear cover must indicate 25° BTC. To adjust timing, loosen distributor body clamp and rotate distributor body. If timing is early (25° mark to the right of the point), rotate distributor clockwise to retard ignition point, or counterclockwise to advance timing.

TIMING — JB AND JC VACU-FLO ENGINES

The procedures for timing Vacu-Flo engines is the same as for the standard JB-JC air-cooled engines, except for the location of the timing pointer. The pointer bracket is mounted on the backplate below the gear cover. It is viewed through the lower dot button hole on the left side of the engine shroud.

The TC mark and timing degree marks are stamped on the flywheels at the factory to correspond with the timing pointer at the most convenient position for viewing during timing.

Remove the lower dot button on the left side of the shroud for viewing and aligning the TC or 25° (35° for gaseous fuel) mark and timing pointer. The molded pointer on the gear cover has no function on Vacu-Flo engines.

Tighten distributor in its mount and recheck timing.

CAUTION If the relative position of the timing marks doesn't remain steady, the distributor may be defective. This can be caused by pitted or misaligned breaker points, incorrect breaker point spring tension, worn or loose breaker plate, or a worn distributor shell or bushing.

DUAL POINTS AND COILS

The MJC and some JC electric generating sets use a Radio Frequency Interference (RFI) suppressed battery ignition system with two separate coils, a distributor with spark advance and dual breaker points, two condensers, and four shielded spark plugs. Figure 10-54. The two condensers are mounted vertically between the two point sets inside of the distributor, Figure 10-55. This ignition system uses resistor spark plugs and shielded high tension spark plug leads to suppress ignition noise that causes radio interference. The major difference between the single points and dual point ignition systems involves timing. Maintenance, testing, repair, disassembly, assembly, and installation procedures for single and dual point distributors are almost identical. Therefore, separate timing procedures will be given here for dual points type ignition systems.

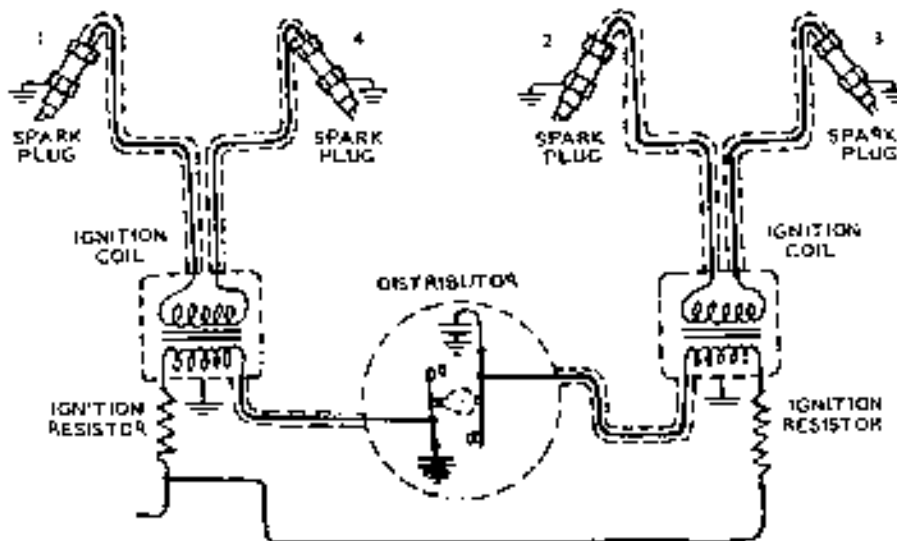

FIGURE 10-54. DUAL POINTS IGNITION SYSTEM

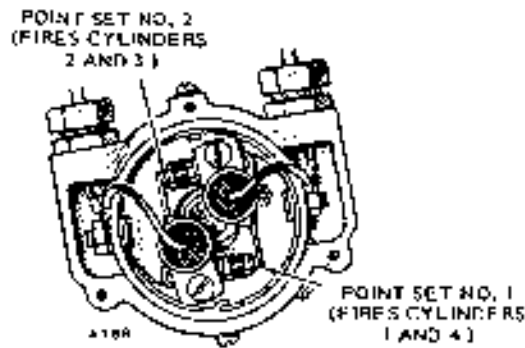

FIGURE 10-55. DUAL POINTS DISTRIBUTOR

DUAL POINTS TIMING

Ignition timing adjusts the distributor so the spark at each cylinder fires at the correct time for maximum power (25° BTC on each compression stroke). The dual points ignition timing system may be timed either with the engine stopped or running. Before timing the ignition, be sure both sets of breaker points are clean and properly adjusted to .018 to .022 inch (0.46 to 0.56 mm) Figure 10-56. Breaker point set No. 1 opens to fire cylinders 1 and 4 simultaneously and point set No. 2 opens to fire cylinder 3 and 4 simultaneously. One cylinder fires on the compression stroke while the other fires ineffectively on the exhaust stroke. Time engine as follows:

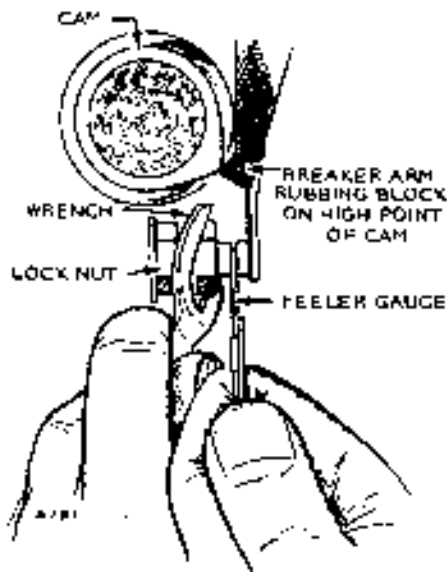

FIGURE 10-58. SETTING DUAL BREAKER POINTS

Engine Stopped:

1. Disconnect low voltage (primary) lead from coil No. 1 to distributor to isolate the coil. Connect a battery test lamp across No. 1 set of points to ground so lamp lights when breaker points are closed and goes out when points open.

2. Remove spark plug from No. 1 cylinder and rotate flywheel clockwise until air is forced out of spark plug hole on compression stroke.
3. Continue rotating flywheel slowly to point where test lamp goes out, indicating breaker points have opened. This is the ignition point and timing is correct if TC mark on flywheel aligns with the timing pointer. Otherwise, the distributor must be adjusted to advance or retard the spark.
4. To change timing, align flywheel TC mark at timing pointer. Then loosen the distributor lock screw and rotate the distributor (clockwise if ignition occurred early and counterclockwise if ignition occurred late) to point where light goes out.
5. Retighten distributor lock screw in new position and recheck timing, step 3. If necessary, repeat steps 3 and 4 until correct timing point is attained.
6. When the No. 1 set of points are properly timed, the No. 2 set of points should open at the proper time, if the gap is .018 to .022 inch (0.46 to 0.56 mm).

Engine Running:

1. Install automotive timing light to spark plug for Cylinder No. 1 following the manufacturer's instructions.
2. Run set at rated speed. Aim flashing timing light toward flywheel through lower dot button hole.
3. If timing pointer indicates 25° BTC, timing is correct for cylinders 1 and 4. Otherwise, loosen distributor lock screw and rotate distributor clockwise to retard and counterclockwise to advance ignition point. Tighten distributor lock screw and recheck timing with light.

If the relative position of the timing marks doesn't remain steady, the distributor is probably defective. Pitted or misaligned breaker points, incorrect breaker spring tension, and a worn or loose breaker plate, distributor shaft or bushing all affect proper timing.

Testing

Remove the distributor and test it on a commercial tester. Following the equipment manufacturer's instructions, check the centrifugal advance mechanism and cam dwell angle. The cam dwell angle should be 51 ± 3 degrees. Do not set breaker gap by cam dwell. With the proper point gap, if cam dwell is outside the above limits, check for worn distributor cam.

If a distributor tester isn't available, test as follows:

To check the spark advance mechanism, remove the distributor cap and rotate the rotor several degrees clockwise. If the advance mechanism is operating properly, the rotor will return to its original position.

Thoroughly inspect the breaker points and check to be sure the movable contact turns freely on its pivot.

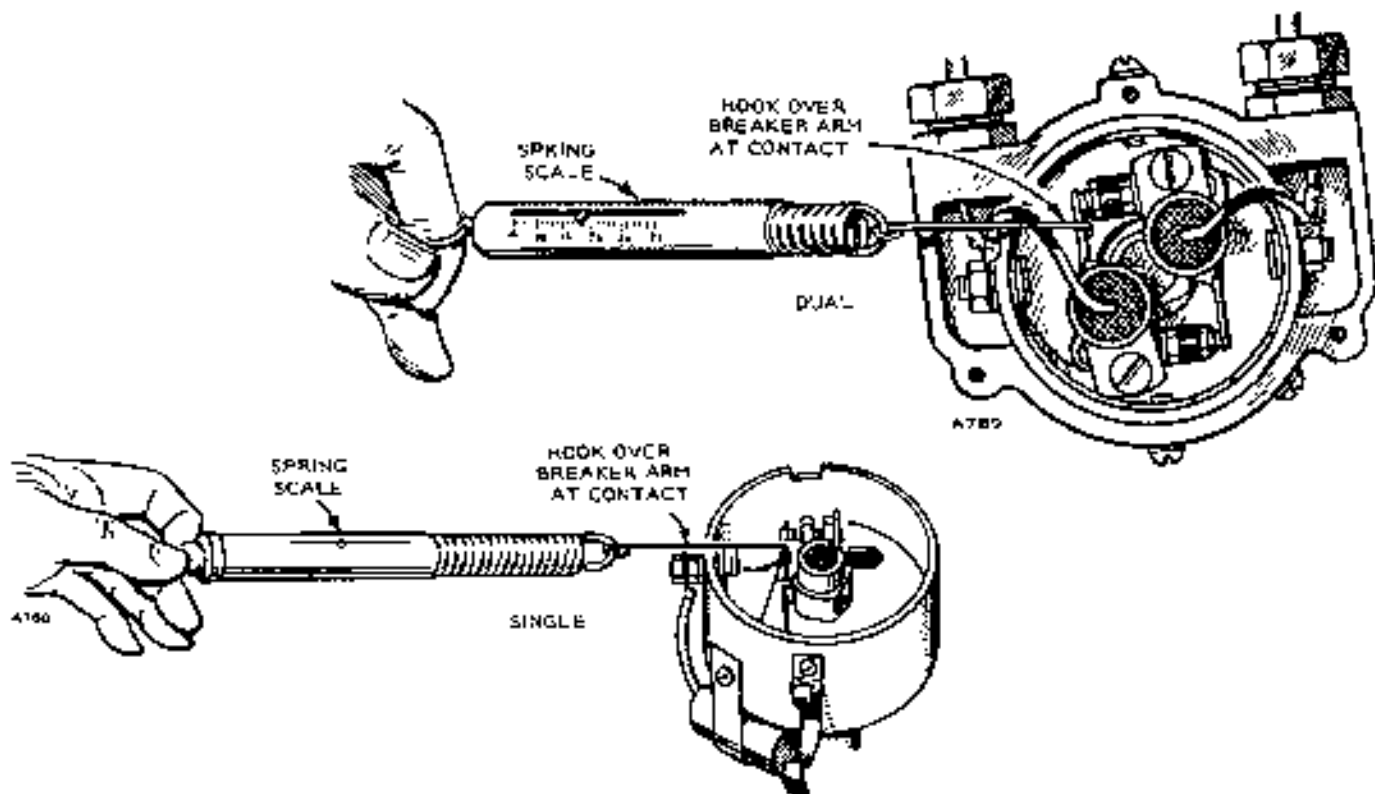

FIGURE 10-57. CHECKING BREAKER POINT SPRING TENSION

Using a spring scale, measure the tension of the points as they break contact, Figure 10-57. Tension should be 17 to 20 ounces (23.5-27.6 N). If it is greater, it causes excess wear; if less, it causes contact bounce. To adjust tension, refer to *Distributor Assembly*.

Removal and Disassembly

1. Remove distributor cap by releasing clips on distributor. Remove primary lead from distributor terminal.
2. Record distributor body position and rotor position for easier assembly in proper position.
3. Remove distributor hold-down capscrew and pull distributor out of crankcase.
4. Remove three screws holding breaker plate to distributor housing and loosen primary lead mounting terminal. Lift breaker arm off its hinge.
5. Rotate breaker plate counterclockwise about 45 degrees and pull it out of distributor body. Remove two centrifugal advance springs.
6. Remove spring clip (cam retaining spring) holding cam to drive shaft and lift out cam. The weights are now free and can be lifted out, Figure 10-58.
7. To remove drive shaft, grind or file off peened-

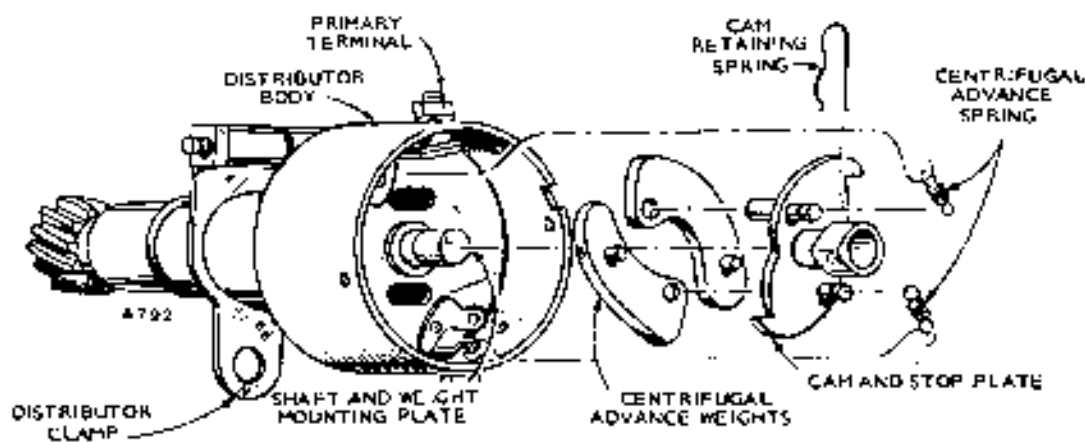

FIGURE 10-58. DISTRIBUTOR DISASSEMBLY

over end of pin holding drive gear to shaft. Drive out pin, then remove gear and pull shaft out through distributor body.

8. If necessary, press two bronze bearings out of distributor body.

Repair

Clean all components except the condenser, breaker points and bushings in light cleaning solvent. Inspect the centrifugal advance component for signs of wear and replace any that appear worn or otherwise damaged. Inspect the cam and shaft for wear or score marks. If either is scored, replace it.

To check bearing wear, set the drive shaft into the body and measure the side play at the top of the cam with a dial indicator. Mount the indicator on the distributor body, and measure the side play by pulling the shaft directly away from the indicator with a force of about five pounds. Side play should be less than .005 inch (0.13 mm). If not, the bearings must be replaced. Onan does not recommend field replacement of bronze shaft bearings unless the required equipment is available. This can be done by an authorized service station.

Distributor Assembly

1. Install shaft assembly with upper drive shaft thrust washer in distributor body. Install lower drive shaft thrust washer and drive gear. Install a pin through drive gear and shaft and peen it into place.
2. Check drive shaft end play, Figure 10-59. It should be between .003 and .010 inch (0.08-0.25 mm). If end play is too small, tap lower end of distributor drive shaft lightly with a soft hammer to increase play. If it is too great, check thrust washer installation or reinstall gear.

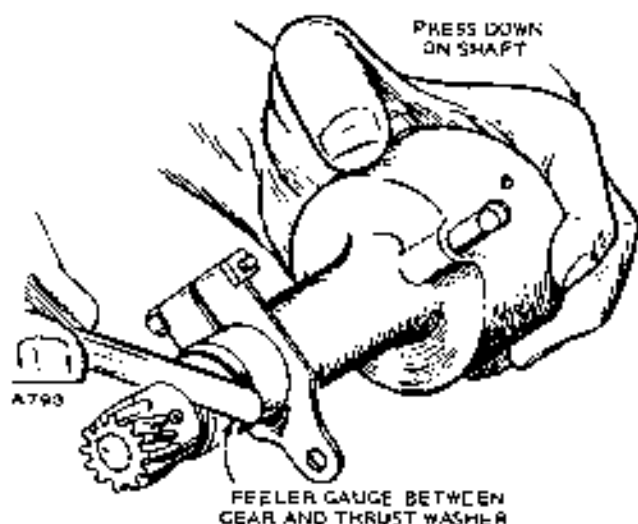

FIGURE 10-59. CHECKING DRIVE SHAFT END PLAY

3. Set centrifugal advance weights into place and install cam. Be sure pivots on cam fit into hole in each weight. Secure cam with spring clip and install weight springs.
4. Install and secure breaker plate.
5. Mount breaker arm on its pivot and place control spring end between end of terminal stud and square metal washer. Then tighten primary terminal.
6. Align contacts so they make contact at center. Bend stationary contact bracket, not breaker arm to align contacts.
7. Check tension of breaker spring with a spring scale hooked on arm at contact and held at right angles to contact surfaces, Figure 10-58. Tension should be 17 to 20 ounces. Adjust it by loosening screw holding end of contact spring and installing spacing washers or sliding end of spring in or out.
8. Rotate drive shaft to obtain maximum breaker gap and set gap for .020 inches (0.51 mm), Figure 10-56.

Distributor Installation

Install the distributor in exactly the same position as before removal. When setting the distributor into position, the rotor should be 1/8 turn counterclockwise from the position when removed, to allow the gears to mesh in proper position.

If the exact position of both distributor body and rotor was not recorded or the crankshaft was rotated, use the following procedure.

1. Remove spark plug from #1 cylinder. Place a finger over spark plug hole and rotate flywheel clockwise until cylinder builds up pressure. Continue rotating until TC mark of flywheel aligns with timing pointer.
2. Install rotor on distributor shaft and "O" ring on body.
3. While holding distributor in position shown in Figure 10-60 and the rotor 1/8 turn counterclockwise from the position shown, push the distributor into its mounting hole. If necessary, turn the rotor slightly to align teeth of gear. If the rotor is not in position shown in Figure 10-60 after the gears mesh, repeat the procedure, changing the gear alignment.
4. Install distributor clamp screw. If spark plug leads were removed from distributor cap, reinstall them in proper firing order, Figure 10-60. Time ignition system.

Ignition Coil and Condenser

The JC engine uses a standard automotive ignition coil mounted on the air shroud near the engine access door. Inspect and tighten the primary terminals. Inspect the secondary terminal and clean it if necessary.

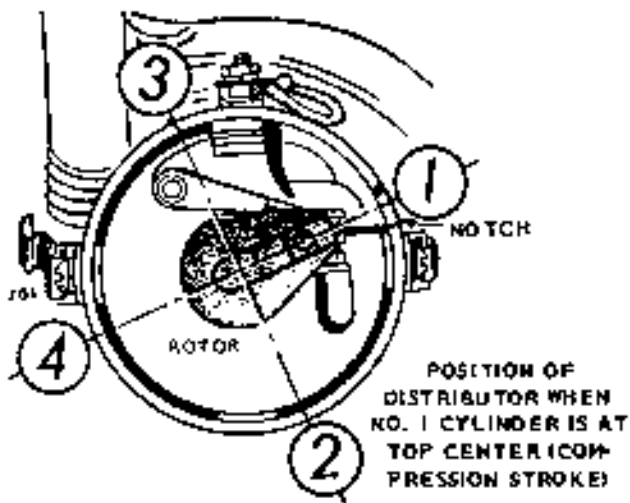

FIGURE 10-60. DISTRIBUTOR POSITIONING

Test the coil either on a standard automotive coil tester or by checking primary and secondary winding resistances. Resistance from the high tension terminal to the ground (-) terminal should be 7,000 to 10,000 ohms; resistance between the primary terminals, about 1 ohm.

The condenser is mounted on the outside of the distributor, Figure 10-59. Capacitance should be .25 to .28 mfd.

MAGNETO IGNITION

Magnetos (Wico or Fairbanks-Morse) are sometimes supplied with JC engines. If the magneto has been removed from the engine for any reason, it must be retimed to the firing order of the engine (1-2-4-3) at the time of installation. Follow the procedure below for installation instructions.

Align the flywheel 19-1/2 teeth before the TDC (top dead center) mark with the pointer on the front cover with No. 1 piston on compression stroke. This procedure is for both magnetos.

Fairbanks-Morse Magneto

Install a piece of ignition wire in the number one cylinder tension terminal. (See Figure 10-61 for firing order.) The other end should be stripped and held 1/2 inch from magneto body. Rotate the magneto drive gear clockwise until a spark is observed from the wire to the magneto body. (This occurs when impulse snaps). After the spark occurs, turn the drive gear counterclockwise until a slight click is heard, then turn clockwise, holding the gear against the impulse. Install magneto on engine; set the magneto in the mid position on the adjustment slots. Connect a timing light on the number one high tension lead; adjust timing when engine is running for the specific fuel being used.

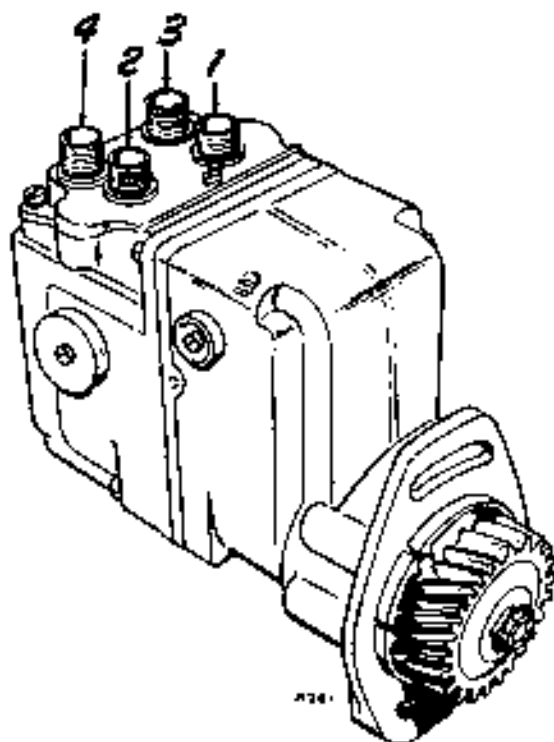

FIGURE 10-61. FAIRBANKS-MORSE MAGNETO

Wico Magneto

The timing procedure is the same as for the Fairbanks-Morse magneto except for locating and positioning the number one firing position on the magneto.

A timing window with an internal indicator is provided to locate the number one position, Figure 10-62.

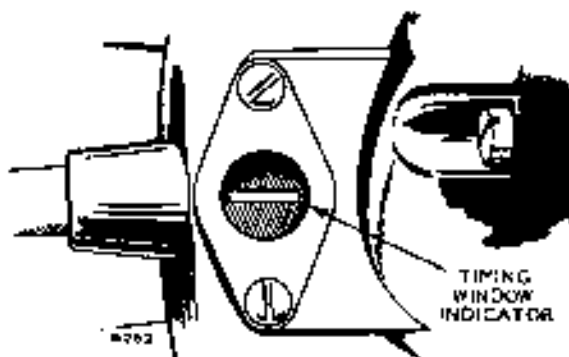

FIGURE 10-62. WICO MAGNETO

Rotate the drive gear counterclockwise until the indicator is observed in the window; continue rotation slightly more until a slight click is heard. This will be the impulse point. The impulse coupling will be locked when turning clockwise. Hold the gear against the impulse and install the magneto on the engine in the mid position of the adjustment slots. Use a timing light; adjust the timing for the specific fuel being used. Magneto firing order is clockwise when viewed from terminal end.

SAFETY PRECAUTIONS FOR ALTERNATOR SYSTEMS

- **Keep all electrical connections clean, tight, and wires intact.**
High resistance due to poor battery connections will cause excessively high rate of charging and cause the battery to use an abnormal amount of water.
- **All regulator checks and adjustments must be made under specified conditions.**
- **Reversed battery connections may damage the rectifiers, wiring, or other components of the charging system. Battery polarity should be checked with a voltmeter to be sure which terminal post is connected to ground before reinstalling battery.**
- **If booster batteries are used for starting engine they must be connected properly to prevent damage to the system.**
- **Anything that affects the battery or regulator affects voltage regulation.**
- **Do not use batteries of higher-than-system voltage either to boost a battery of lower voltage or in starting.**
- **Alternators must not be operated on open circuit with the field winding energized. High voltages will result, causing possible rectifier failure. Make sure all connections are secure.**
- **Do not attempt to polarize the alternator. No polarization is required. Any attempt to do so may result in damage to the alternator, regulator or circuits.**
- **The field circuit must not be grounded at any point. Grounding of the field will damage the regulator.**
If the field lead from the regulator to the alternator is grounded, the battery will charge excessively.
- **Grounding the alternator output terminal may damage the alternator and/or circuit components even when the system is not in operation.**
A short circuit between the stator leads to the rectifier will show a discharge on the ammeter and an undercharged battery will result.

BATTERY CHARGING SYSTEMS

FLYWHEEL ALTERNATORS

Most Onan gasoline and diesel industrial engines and garden tractor engines, and a few RV electric generating sets, use a flywheel alternator system for battery charging. Figure 10-63. Four systems currently are used. Wico (20 amp) Phelon (9 amp), Phelon (15 amp), and Syncro (20 amp). Some industrial engines use a belt-drive alternator.

DESCRIPTION

The flywheel alternator is a permanent magnet alternator and uses a solid-state voltage regulator-rectifier for controlling output. Major components of this flywheel alternator system are:

- The rotor or permanent magnet on the flywheel.
- The stator, a ring of coils mounted on the gear cover.
- The rectifier-regulator mounted on the engine block, and
- Attaching cables.

The rotor provides a rotating magnetic field while the stator magnets cut the field to produce an AC voltage which is rectified (converted) to DC by the rectifier-regulator for battery charging and engine controls.

The permanent magnet (rotor) is fastened to the flywheel by screws. It is fully supported by the flywheel and therefore has no bearings. The stator windings are encapsulated in an epoxy resin for protection from moisture. Cooling of the stator is from special fins on the rotor. The rectifier is located inside the blower housing and cooled by incoming engine air.

On some installations, a 30-ampere fuse is included in the battery charging system to protect the alternator in case the battery cables are accidentally reversed. The fuse is located behind the air housing door. Check the fuse before performing any tests.

A discharged battery indicates trouble in the charging system, but always check the battery for serviceability first.

GENERAL TROUBLESHOOTING NOTES

Keep these points in mind when testing or servicing the flywheel alternator:

1. Be sure output control plug (connector) is inserted properly. The plug must bottom in receptacle to eliminate any resistance due to a poor connection. Keep clean and tight.

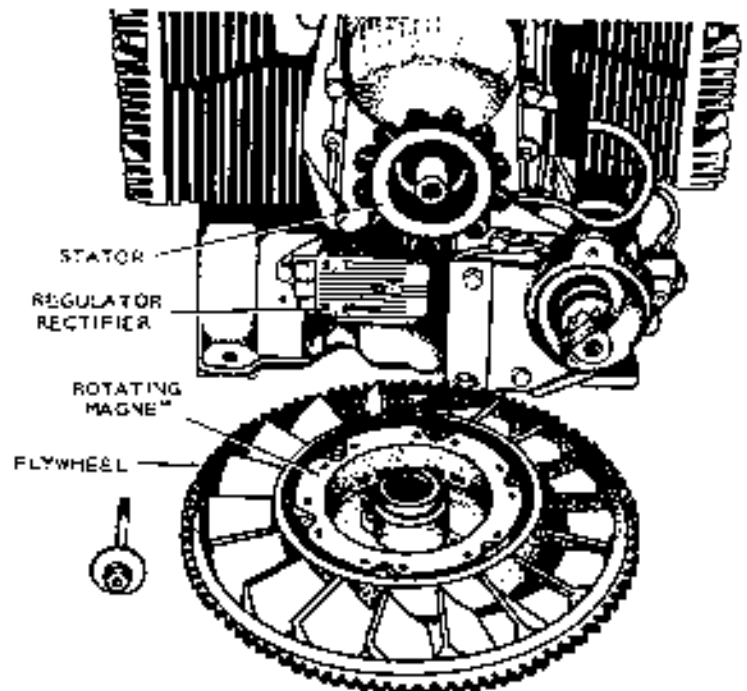

FIGURE 10-63. TYPICAL FLYWHEEL ALTERNATOR SYSTEM

2. Be sure regulator-rectifier output control has a good ground connection. Mating surface for mounting must be clean and fasteners tightened properly. On all Onan flywheel alternator systems, the regulator case is the ground for the system.
3. Make sure alternator stator leads are not shorted together.
4. Be sure all electrical connections are clean and tight.
5. Do not operate charging system without a battery. Damage will occur to regulator and battery ignition coil.

CAUTION

Never reverse battery leads. Reverse polarity will blow the fuse.

6. Check battery to be sure it is fully charged. If not, replace with a fully charged battery. Make sure of battery polarity (negative ground only). Otherwise system could be damaged.
7. Check voltages at battery, regulator and alternator terminals.
 - a. Measure readings while system is operating satisfactorily. This data will make is easier to

REV. 11-78

spot a trouble source when it occurs.

- b. Record separate readings taken from each engine, as they vary from system to system.
8. Check all accessories with an ammeter to make sure they are drawing rated amperes and are not loading the system excessively.

When electrical system trouble occurs there are three general areas to check:

1. Battery and associated wiring.
2. Regulator-Rectifier
3. Alternator

BATTERY CHECK

The battery often reveals the symptoms of a faulty electrical system. The battery is also the culprit in many cases. If the charging system is operating properly, you should expect and get long battery life. But even the best battery has a definite life expectancy and eventually it will fail.

Since batteries have a definite bearing on system operation, it is important to check them often as part of a periodic maintenance program.

Over-charging indicates high battery water usage. If specific gravity varies by more than .25 between cells, it is likely that one of the cells has failed, or is near the failing point. Replacing the battery is advisable.

Battery condition indicates potential problems and should be the first check for good electrical system maintenance. The better the care, the longer all components will last and the more profitable, trouble-free service you'll receive.

Battery Voltage

1. Connect a voltmeter across battery. Start engine and operate at 1800 r/min.
2. Voltmeter should read 13.4 to 14.0 volts. If not, check alternator output first, then install a new regulator-rectifier and retest. Be sure it has a good ground connection and the connector is properly seated.

TABLE 10-4.
WICO 20 AMP FLYWHEEL ALTERNATOR SYSTEM

ENGINE SERIES	APPLICATION
CCKA, NB	Garden Tractor
NH	Industrial Engine
DJBA	Industrial Engine
JR, JC	Industrial Engine
DJA, DJB, DJC	Industrial Engine

20 AMP WICO SYSTEM

Wico alternators and regulators, Table 10-4, can be identified by two yellow wires coming from stator assembly, Figure 10-64.

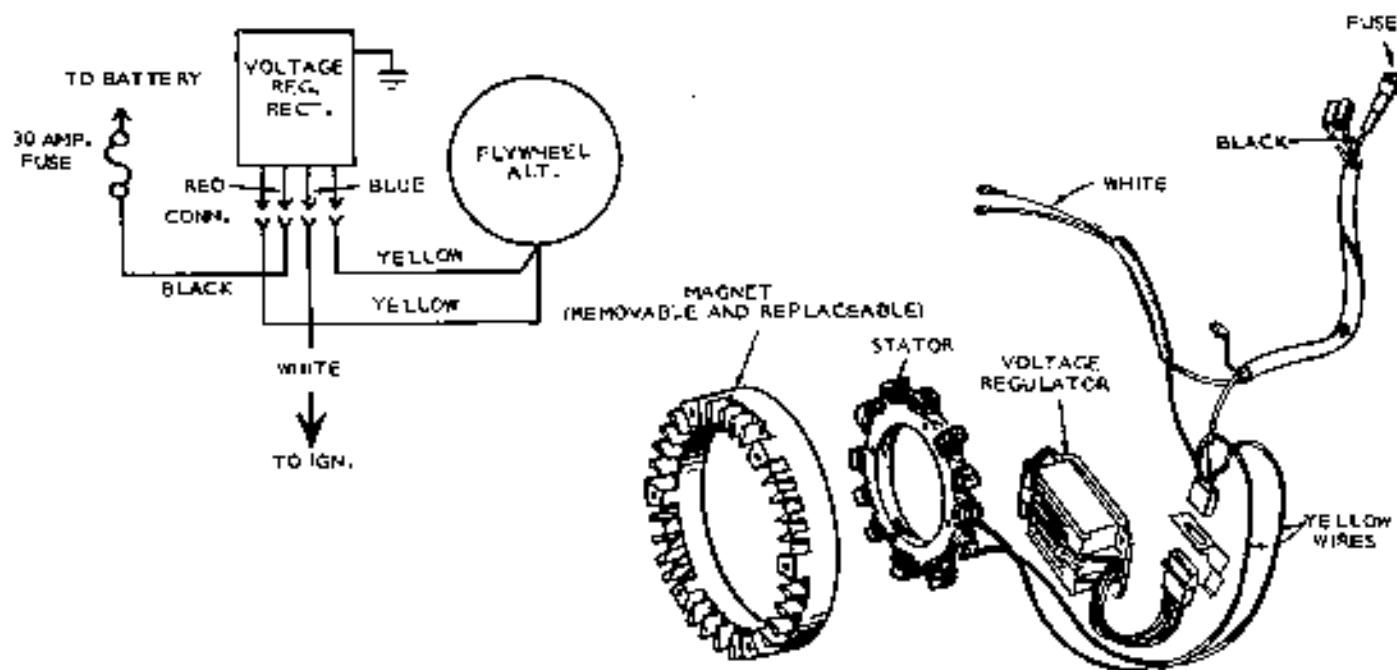

FIGURE 10-64. 20 AMP WICO SYSTEM

REV. 11-76

Table 10-5 lists the test values which apply to the 20 Amp Wico system.

**TABLE 10-5
TESTING 20 AMP WICO SYSTEM**

TEST	VALUE
Battery voltage - unit not running	12 volts DC
Battery voltage with unit running at 1800 rpm or more (fully charged battery)	13.4 - 14 volts DC
AC voltage from stator with plug disconnected and unit running at about 1800 rpm	17 volts AC + 10%
Ohmmeter reading at plug when checking two AC stator leads - unit not running	Less than 3 ohms

Stator Output Check - Engine Running

Voltmeter Test: With the engine running at 1800 r/min, remove connector at regulator and insert an AC voltmeter between the two yellow wires. The AC voltage should read from 17 to 30 volts.

If voltage is considerably less than these figures, either the alternator stator or rotating magnet group is defective. Test stator windings with an ohmmeter (engine not running). Stator winding values are usually less than one ohm. If readings are within limits, then the magnet group is defective.

Stator Winding Check — Engine Not Running

Voltmeter Test: For testing stator use a Simpson Model 270 V.O.M. or equivalent. Set voltage selector switch to DC+. Be sure test meter is in good condition and if battery powered, that the battery is good. Be sure the meter is zeroed before each reading and each time you change scales.

1. Disconnect connector plug at regulator. Zero meter on R x 1 scale.
2. Connect meter leads to the two outside terminals of the female plug (both yellow wires). Meter should read less than 0.8 ohms. This test checks stator winding for continuity. If no reading shows on meter, winding is open - replace stator.
3. To check for grounded stator winding, touch red meter lead to yellow wire plug and other meter lead to metal core. Meter should read infinity. If meter shows a reading then winding is grounded - replace stator.

Flywheel Magnet Group Or Rotor

To test the magnet group or rotor, lay a piece of ferrous (iron) material up against the magnets to be sure they are charged. If not, replace the rotor.

DJC (PRIOR TO SPEC V) AND DJB

Major components in this battery charging system are:

- A permanent magnet on the flywheel provides a rotating magnetic field;
- A group of coils mounted behind the flywheel on the gear cover cut the field to produce a voltage;

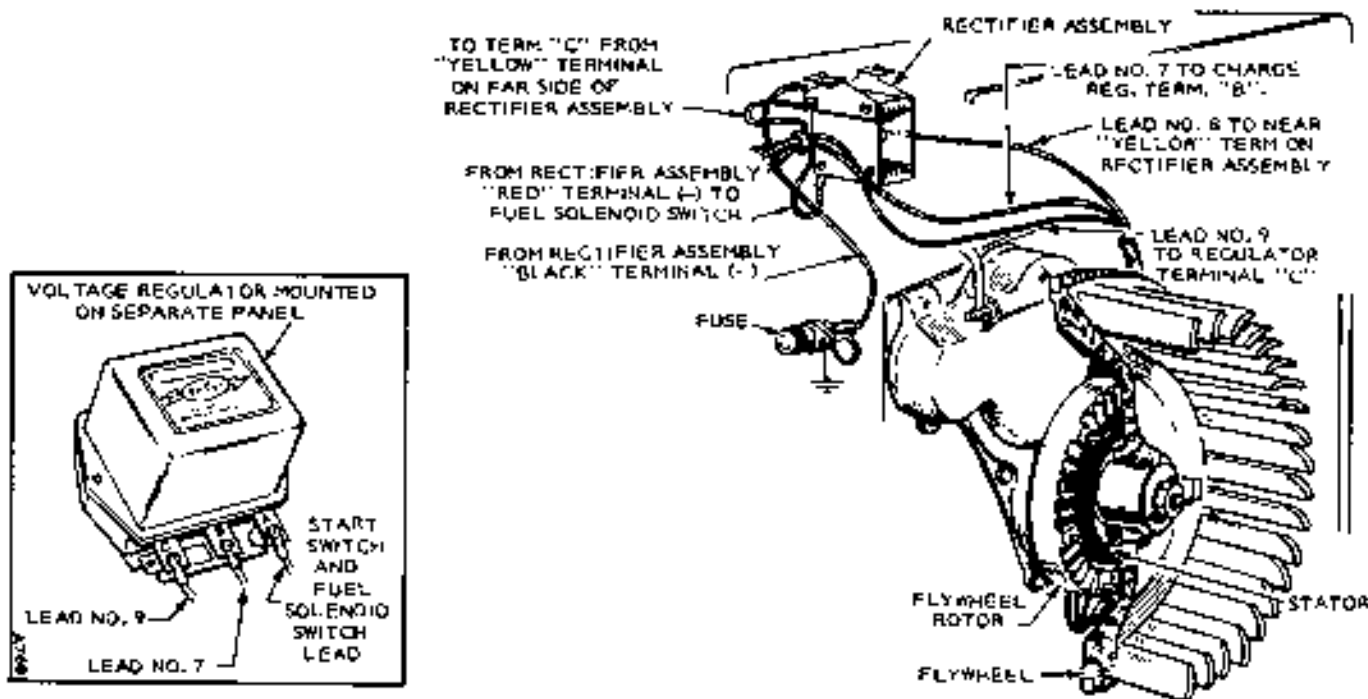

FIGURE 10-65. FLYWHEEL ALTERNATOR

REV. 11-76

- A two-step mechanical regulator controls the AC voltage to the rectifier, and
- A full wave rectifier converts the regulated AC to DC for battery charging. Alternator components are shown in Figure 10-65.

A fuse between the rectifier and ground protects the rectifiers from destruction should the battery be connected in the circuit with reversed polarity. The mechanical regulator cannot tolerate normal vibration of the engine, so it must be mounted on a separate panel.

The alternator develops two different rates of current output. The smaller output is connected in the charge circuit for a continuous low-rate charge. The larger output is controlled by the mechanical regulator which has two relays, one of which is voltage-sensitive. When battery voltage falls and the voltage-sensitive relay is de-energized, contacts close to provide a circuit to the other relay, which makes a circuit for the high-rate charge. See Figure 10-66 wiring schematic. The voltage at which the sensitive relay is energized varies with the temperature.

The final result is a charge rate of 12 amperes into a 70 amp hours, 12 volt battery when the engine is running at 1800 rpm. The maximum continuous DC load is limited to 10 amperes at 1800 rpm. Reverse current through the rectifiers is 5 to 10 milliamperes, so no special reverse current protection is needed.

Maintenance

Maintenance is limited to keeping the components in good condition. When the flywheel is off, clean the rotor and stator and check the wires. In general, see that all connections are secure and all components clean. If the alternator is operating satisfactorily, do not tamper with it.

Testing

To check alternator output, connect an ammeter between the red terminal on the rectifier and the ignition switch. With the engine running at 1800 rpm, the ammeter should indicate about 8 amperes into a fully discharged battery, and progressively less as the battery becomes charged. The regulator switches from high to low charge at about 14-1/2 volts and from low to high at about 13 volts. Current at low charge should be about 2 amperes. If output is unsatisfactory, do the following tests.

Rotor: To test for magnetism in the rotor, merely hold a piece of steel close to the magnet. If the steel is strongly attracted, the rotor is satisfactory. Strength of the magnet is a basic quality that will not change much over a period of time.

Stator: Disconnect the stator leads and test each one with a 12 volt test lamp for grounding. Touch one probe to the lead and the other probe to a good ground on the engine. None of the leads should show a ground, which will be indicated if the lamp lights. If the ground is indicated, replace the stator.

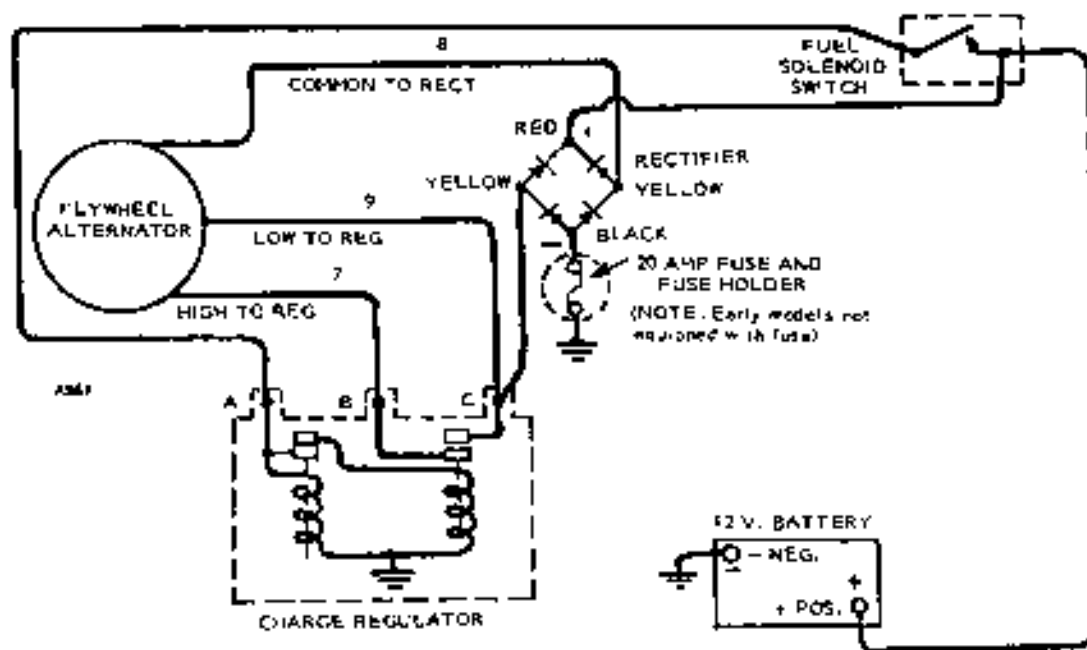

FIGURE 10-66. BATTERY CHARGING SCHEMATIC DIAGRAM

REV. 11-76

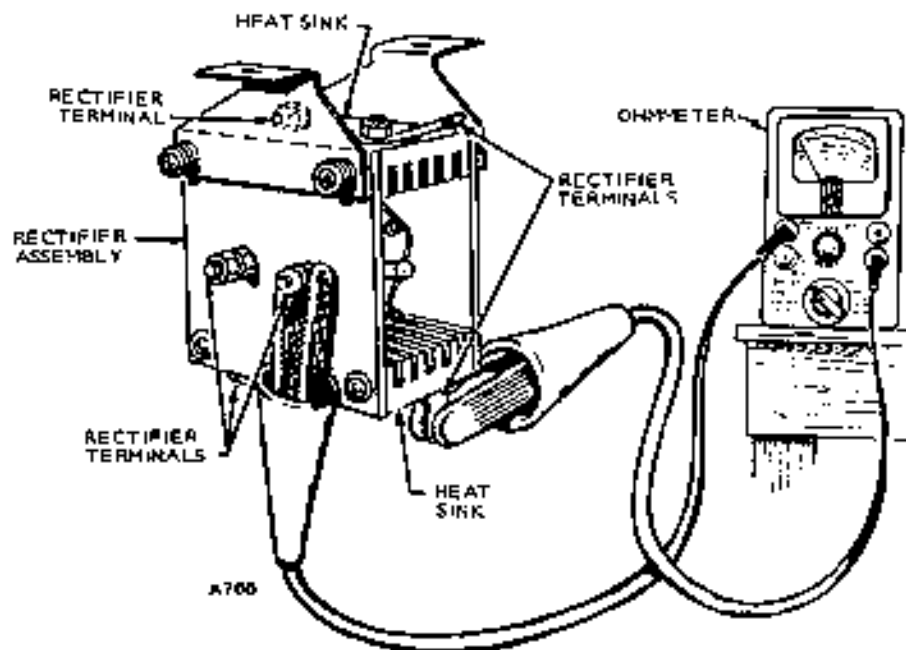

FIGURE 10-67. RECTIFIER TESTING

To test for shorted coils or opened circuits, use an ohmmeter, set to read the proper range of resistance. The resistance values are as follows:

- Lead 7 to 8 — 0.25 ohms
- Lead 8 to 9 — 0.95 ohms
- Lead 9 to 7 — 1.10 ohms

If the resistance varies over 25 percent from the above values, install a new stator and check for improved performance.

Voltage Regulator

If the low-rate charge is satisfactory, but high rate is not: (Refer to Figure 10-66).

1. Connect a jumper between terminals B and C.
2. Run engine and check charge rate at battery; it should be about 8 amperes.
3. If it is, either the regulator or its power circuit is defective.
4. With a 12 volt test lamp, check input to the voltage-sensitive coil at terminal A. If the lamp lights, input is sufficient and the regulator is defective.
5. If charge rate with B and C jumped is low, look to alternator or its wiring for cause.

Indicator Light

This light is used on engines with factory-mounted controls. The light mounts on the rear cylinder air housing, and lights red when the alternator is charging.

Rectifier

Completely isolate the rectifier assembly from the charging circuit by disconnecting all four wires. Test each rectifier separately with an ohmmeter, Figure 10-67.

1. With an ohmmeter, connect one test lead to rectifier lead and other test lead to rectifier base. Take the reading and then reverse test probes.
2. If the rectifier is good, one reading will be much higher than the other.
3. If a 12 volt test lamp is used, touch test probes together and observe brightness of bulb.
4. Touch probes across rectifier. If the rectifier is good, bulb will light dimly. If bulb lights brightly or not at all, rectifier is defective, and must be replaced.

Ammeter Test

1. Check the alternator for stator output by shorting between the regulator F terminal and ground with a screwdriver.
 - a. Operate engine slightly above idle speed, (1500 rpm) and note reading on ammeter.
 - b. All accessories must be turned off when this check is made.
 - c. If output is increased (note ammeter reading) the alternator or rectifier is not at fault.

- d. The trouble is probably due to an improper regulator voltage setting or a defective regulator.
 - e. Check regulator voltage setting.
2. If no output is obtained, the alternator is defective.
 3. Both field winding and stator winding should be checked with an ohmmeter.

20 AMP SYNCHRO SYSTEM

The 20 amp flywheel alternator systems use a separate regulator and a separate rectifier, Figure 10-68.

There are two black wires and one red wire coming from the stator assembly.

TABLE 10-6.
20 AMP SYNCHRO SYSTEM

ENGINE SERIES	APPLICATION
CCKB-M5/2440	Garden Tractor
NHAV, NHBV, NHCV, NHPV	Industrial Engines

Use a Simpson 260 (or equivalent) voltmeter-ohmmeter for testing Synchro stator resistance values, DC values, and AC voltage outputs from the stator with the plug disconnected and unit running at various engine speeds. Refer to Table 10-7.

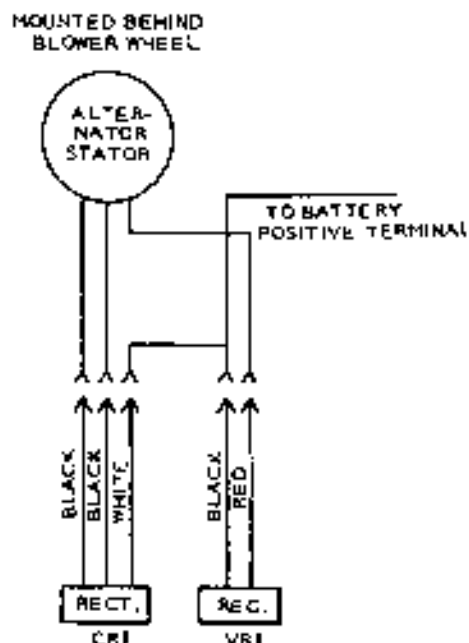
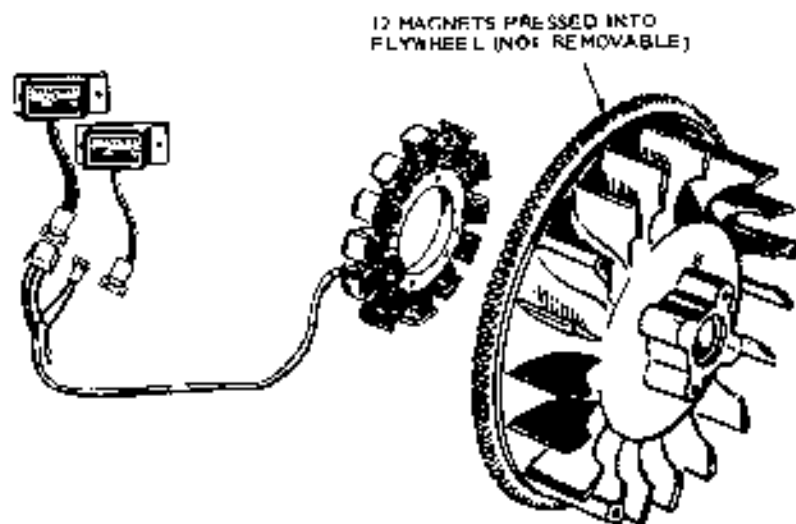

FIGURE 10-68. 20 AMP SYNCHRO SYSTEM

REV. 11-76

TABLE 10-7.
TESTING 20 AMP SYNCHRO SYSTEM

DC TEST	VALUE
Battery voltage - unit not running	12 Volts DC
Battery voltage with unit running at 1800 r/min or more	14.2 - 14.8 Volt DC

Resistance values (Ohms) are as follows between wire pairs.

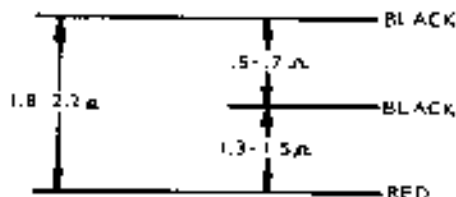

ENGINE RPM	USE SIMPSON 260 FOR AC VOLTAGES		
	RED TO GND.	BLACK TO GND. (Either Lead)	BLACK TO BLACK
500	35	8.5	17
1000	60	15	30
2000	115	29	58
3000	160	40	80
3600	185	46	92

Rectifier Assembly Check

Examine each of the two diodes for breakdown by connecting ohmmeter (Rx1 scale) from one black lead to white lead. Meter should read 10 ohms in proper polarity. A shorted diode would read zero resistance and would cause a short circuit through the lead winding when in operation. An open diode would read infinity in both directions indicating that replacement is necessary.

Regulator Assembly Check

To check for proper voltage regulation, attach a DC voltmeter to battery and operate engine at about 1800 r/min. Battery voltage will climb to the preset factory setting (14.2 to 14.8 volts)

Some installations may vary due to voltage drop in the length of ammeter harnesses. Other variations may stem from a loose connector in the harness or corroded battery leads. Low voltage readings at the battery mean poor battery connections.

To test regulator, remove connector. Using the Rx10,000 scale of your ohmmeter, connect one meter lead to red leadwire and other meter lead to regulator base. No deflection should be noted on the ohmmeter in either polarity. Next connect meter to black leadwire and base of regulator. Meter will deflect fully in one polarity with no deflection in the other.

Full Charge—Will Not Regulate: Check for broken leads at connection to regulator plates. To be sure regulator winding operates properly, connect red lead to ground and start engine. A maximum of 4 amperes should be noted. This would indicate stator winding is satisfactory. If so, replace regulator.

No Charge: If alternator does not charge when load is applied to battery, shut off engine and disconnect one red leadwire from regulator terminal. Be sure lead is taped or isolated from conducting engine parts. Once again, start engine. Alternator should charge to full output; if it doesn't, replace stator assembly.

9 AND 15 AMP PHELON SYSTEMS

The 9 amp system is used on some 1800 rpm RV electric generating sets.

The 15 amp system has two white wires coming from stator and is used on 3600 rpm (maximum) engines. Table 10-8 lists the engine and generator set series that use the 9 and 15 amp Wico systems.

TABLE 10-8. PHELON 9 AND 15 AMP SYSTEM

SERIES	APPLICATION	ALTERNATOR SYSTEM
4.0BF-1R/9000 4.0BF-1R/9500 6.0NH-1R/9000 6.0NH-1R/9500	Electric Generating Sets for Recreational Vehicles	Phelon 9 Amp @ 1800 rpm
BF CCKB-MS/2420 NHA, NHB, NHC	Garden Tractor Garden Tractor Industrial Engine	Phelon 15 Amp @ 3600 rpm

TABLE 10-9. TESTING 9 AMP PHELON SYSTEM

BASIC TEST	PROCEDURE	TEST VALUES
1. Battery	Battery Voltage - unit not running	12 VDC
2. Regulator	Battery Voltage after unit is running 3 to 5 minutes	13.6 to 14.7 VDC
3. Alternator Stator and Wiring with Fully Charged battery.	Ohmmeter reading from stator output - unit not running. Disconnect wire terminating at AC terminal of voltage regulator and wire terminating at BAT terminal of start solenoid. Insert AC voltmeter between these wires.	.2 to .6 Ohms
4. Alternator Stator and Wiring	Measure AC stator output voltage with unit running. Disconnect wire terminating at AC terminal of voltage regulator. Measure AC voltage (unit running) between this wire and BAT terminal of start solenoid.	28 VAC

TABLE 10-10. TESTING 15 AMP PHELON SYSTEM

BASIC TEST	PROCEDURE	TEST VALUES
1. Battery	Battery Voltage - unit not running	12 VDC
2. Regulator	Battery Voltage after unit is running 3 to 5 minutes	13.6 to 14.7 VDC
3. Alternator Stator and Wiring with Fully Charged Battery.	Ohmmeter reading from stator output unit not running. Check at plug	.11 to .19 Ohms
4. Alternator and Wiring	Measure AC open circuit stator voltage with unit running. Measure between two stator leads with plug disconnected and unit running at approximately 3600 rpm.	28 VAC

The flywheel alternator systems, Figure 10-69, have a one piece regulator-rectifier assembly. Various alternator problems are listed in Tables 10-9 and 10-10.

Testing

With the engine running between 1800-2600 r/min, observe the panel ammeter (if not already equipped, connect a test ammeter). If no charging is evident, proceed with the NO CHARGE TEST. If ammeter shows a constant higher charge rate, follow the HIGH CHARGE RATE TEST procedure.

No Charge Test: Perform as follows:

1. Check B+ to ground voltage using a DC voltmeter. See Figure 10-69 for wiring diagram.
2. If voltmeter reads 13.8 volts or higher, add a load to system to reduce battery voltage to below 13.6 volts.

3. Observe ammeter. If charge rate increases, consider system satisfactory. If charge rate does not increase, proceed with testing.
4. Disconnect plug from regulator-rectifier and test the AC voltage at the plug with engine running. If AC voltage reads less than 28 volts, at rated r/min; replace stator. If AC voltage is more than 28 volts, replace regulator-rectifier assembly.

High Charging Rate Test: Perform this test as follows:

1. Check B+ to ground voltage with a DC voltmeter.
2. If voltmeter reads over 14.7 volts, replace regulator-rectifier assembly.
3. If reading is under 14.7 volts, system is probably okay. Recheck battery and connections. If battery does have a low charge, but accepts recharging, system is okay.

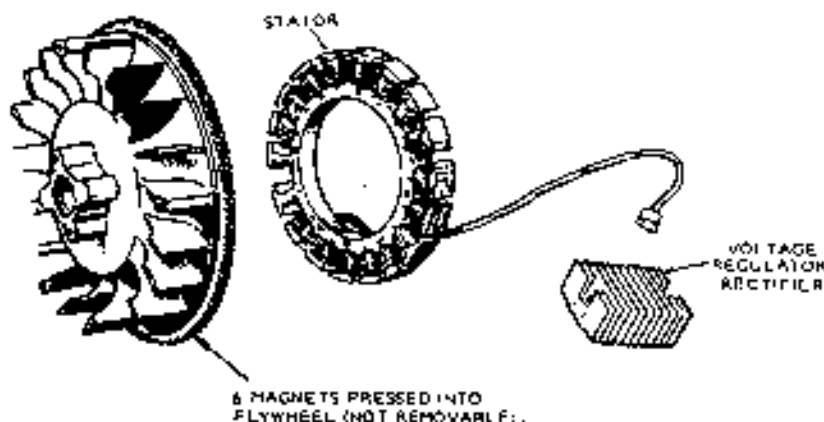
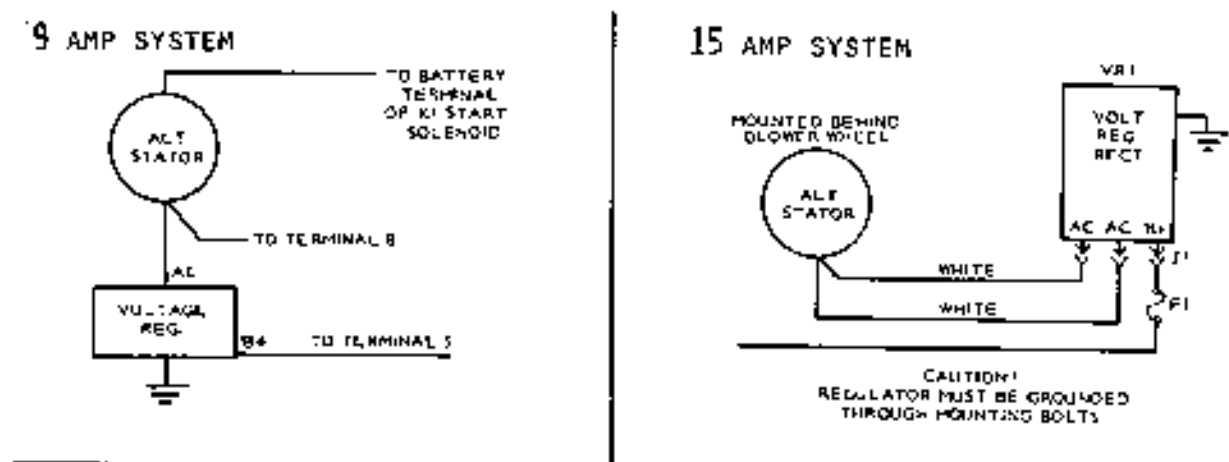

FIGURE 10-69. PHELON 9 AND 15 AMP SYSTEM

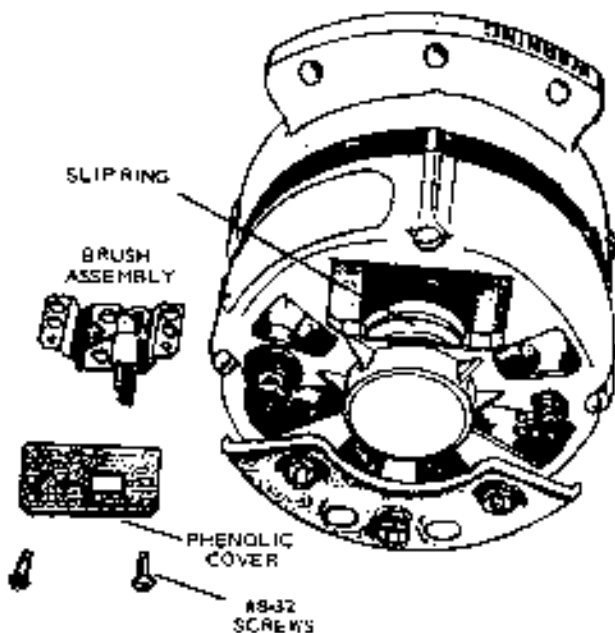

FIGURE 10-70. BELT DRIVEN ALTERNATOR

BELT DRIVEN ALTERNATORS

The belt-driven, 12 volt alternator (Figure 10-70) is used on CCKA, CCKB, RCCK, RDJE, RDJEA, RDJF and NH series engines as an optional item. The wiring diagrams for both top and side mounted alternators are shown in Figures 10-71 and 10-72. Alternator maintenance includes brush replacement and continuity tests.

Brush Assembly Removal

1. Remove three screws which fasten voltage regulator to alternator.
2. Disconnect regulator leads and remove regulator.
3. Remove two screws on phenolic cover and lift out cover and gasket.
4. Pull brush assembly straight up and lift out.
5. Reverse the procedure for assembly.

Brush Assembly Tests

1. Connect an ohmmeter or 12 volt test lamp to the field terminal and to the bracket. The test lamp shouldn't light or resistance reading should be high (infinite). If not, there is a short and the assembly must be replaced.
2. Move one ohmmeter lead from bracket to insulated brush. Use an alligator clip directly on the brush. Be careful not to chip it. Resistance reading should be zero (continuity).
3. Connect ohmmeter leads to the grounded brush and bracket. Resistance should be zero (continuity).

TESTING DIODES

Before checking diodes for shorts or opens, disconnect battery leads, voltage regulator, condenser lead, and diode leads from the harness and remove fuses. Check the condenser for shorts and for proper grounding.

Condenser capacity is about .2 microfarads.

When using an ohmmeter to test diodes for shorts and opens, check each diode twice by reversing the polarity of the negative and positive test lead connections.

1. Connect red and black test leads as shown in Figure 10-73 between the center post and the base.
2. A zero reading in both tests indicates diode is shorted.
3. A normal diode will show a high reading in one direction and a low reading in the opposite direction.
4. An infinite (very high) reading in both tests indicates the diode is open.
5. Before replacing a diode, coat the diode threads with silicone grease or light engine oil, and then tighten to 150-180 inch-pounds (17-20 N•m) of torque.

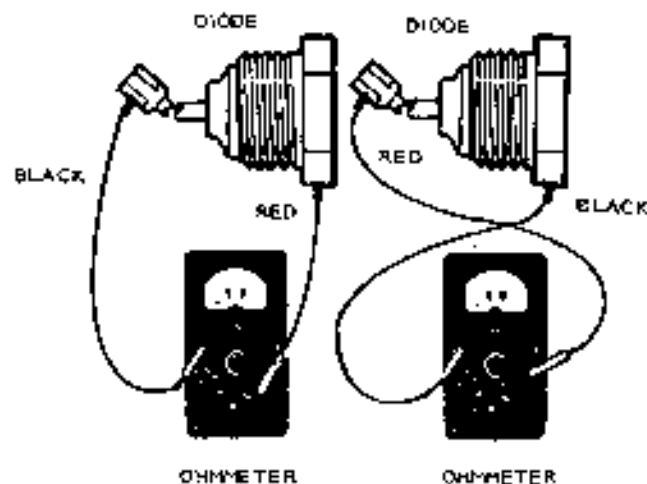

FIGURE 10-73. DIODE TEST CONNECTIONS

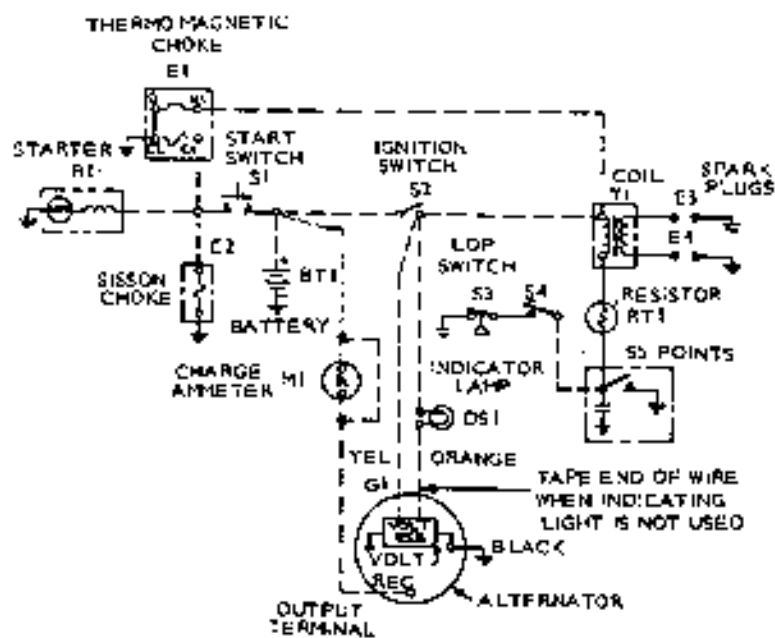

FIGURE 10-71. WIRING DIAGRAM FOR SIDE-MOUNTED ALTERNATOR (OMAN 191-0572)

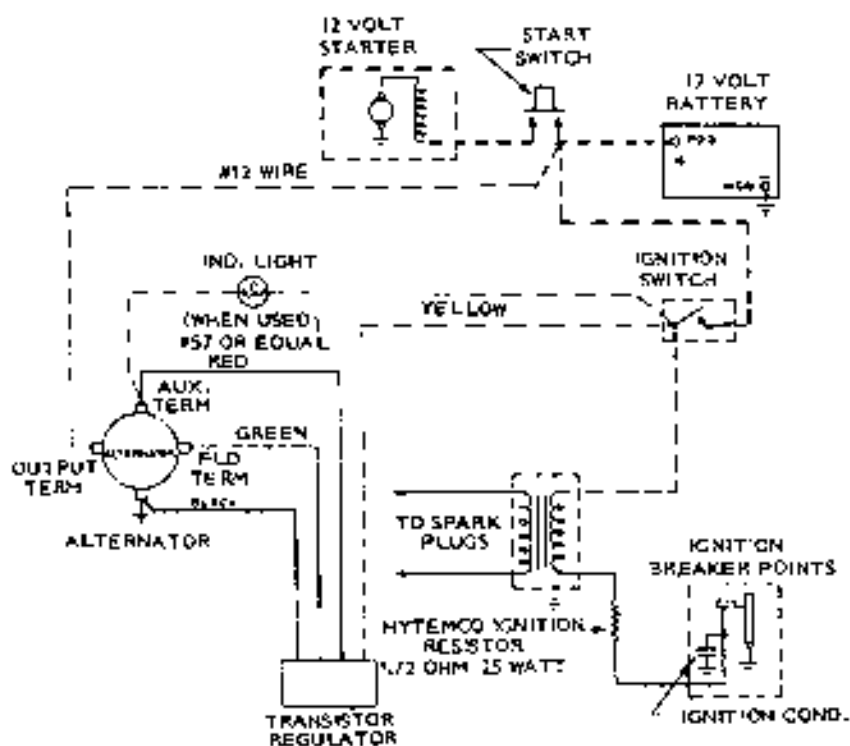

FIGURE 10-72. WIRING DIAGRAM FOR TOP-MOUNTED ALTERNATOR (OMAN 191-0543)

SPARK PLUG MALFUNCTIONS

Dirty fuel that causes fuel filters and carburetor jets to clog is probably the major cause of engine failure. Spark plugs that malfunction for one reason or another are also major causes of engine troubles. The following information describes and identifies several of the most common spark plug malfunctions.

NORMAL IGNITION

Normal ignition occurs when a spark of adequate energy is delivered at the correct instant across the electrode gap. Normal ignition requires spark plugs in good condition.

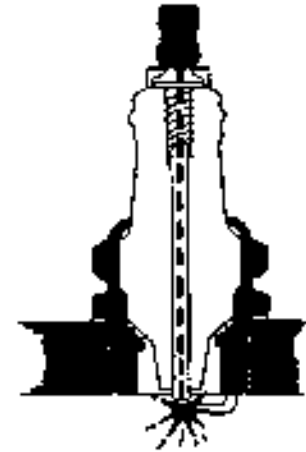

TRACKING IGNITION

Tracking ignition occurs when the spark, jumping from one deposit "island" to another, ignites the fuel charge at some point along the insulator nose. The charge does not actually misfire, but the effect retards ignition timing.

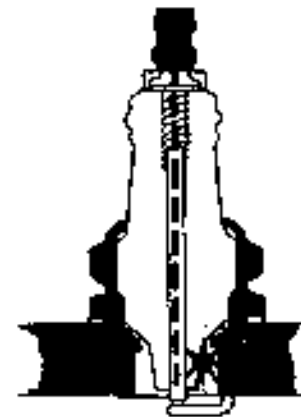

SURFACE IGNITION

Surface ignition occurs when some surface in the combustion chamber becomes hot enough to ignite the fuel charge. Usually this occurs before the spark and is then termed preignition. The source of this may be an overheated spark plug, valve or cylinder deposits.

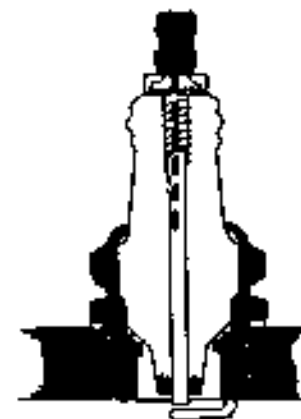

REV. 11-76

WIDE ELECTRODE GAP

Wide electrode gap exists when the spark plug electrodes are worn so badly that the ignition voltage is insufficient to jump the gap.

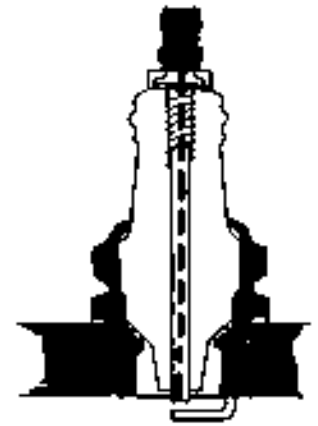

BRIDGED GAP

Bridged gap occurs when deposits fill in the gap between the center electrode and the side electrode. Coil voltage is consequently drained away without any spark occurring. A plug with this particular malfunction can often be cleaned and reinstalled.

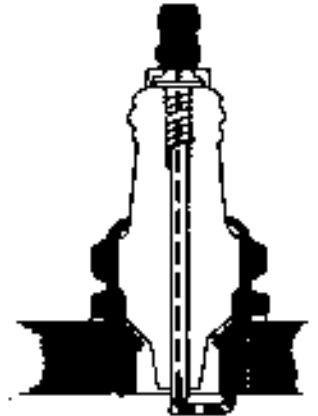

FLASHOVER

Flashover exists when voltage shorts over the outside of the insulator. Dirt, moisture, or a deteriorated boot are causes of flashover.

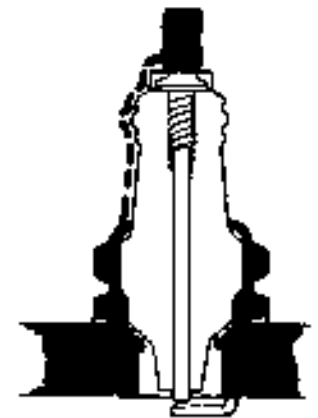

CRACKED INSULATOR

High voltage may short circuit to ground through a crack in the plug insulator. Replace such a plug.

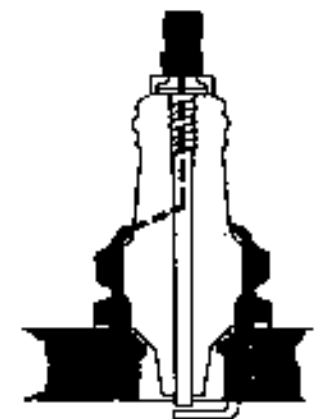

FOULED PLUG

Conductive deposits may form on the insulator surface draining away ignition voltage. Clean and test or replace plugs in this condition.

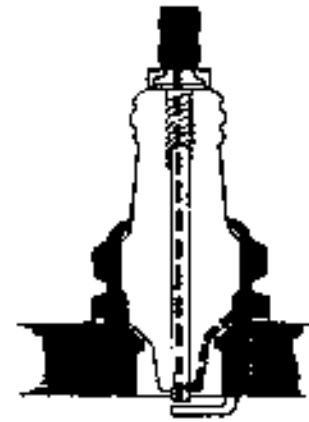

SPARK PLUG ANALYSIS

Determining the condition of spark plugs when removed from an engine often pin points the source of engine problems. When removing the spark plugs, place them in a tray or rack corresponding to cylinder position. This makes it easier to locate the trouble sources in your engine. See spark plug analysis that follows.

ALL PLUGS NORMAL

If all plugs have a light tan or gray colored deposits and a small amount of electrode wear (not more than about .005" gap growth), plugs can be cleaned, regapped and reinstalled.

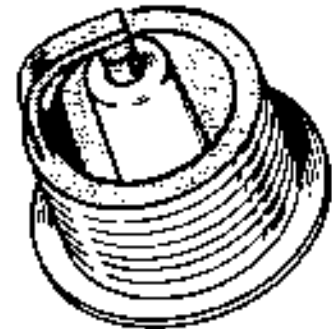

ONE PLUG FOULED

If one plug in a set is carbon fouled and the other plugs are normal, check the corresponding ignition cable for continuity. A compression check or cylinder leak test should also be performed on the cylinder.

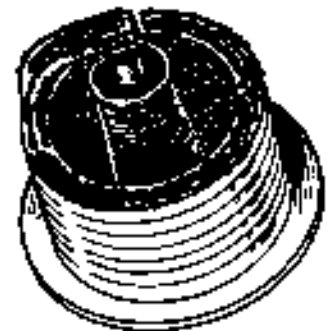

ALL PLUGS OIL FOULED

When all plugs are oil fouled, too much fuel is entering the cylinders during cranking. If the choke plate is operating properly, fouling is due to poor engine oil control.



ALL PLUGS WORN

If all plugs have tan or gray colored deposits and excessive electrode wear (.008" to .010" more than original gap), replace them. They are worn out from normal service.



ALL PLUGS OVERHEATED

When the entire set has dead white insulators and badly eroded electrodes, install the next colder plug.



ONE PLUG BADLY BURNED

If one plug has melted electrodes, preignition is the likely cause. Check for intake manifold air leaks and possible cross fire. Be sure that one plug is not the wrong heat range.



ALL PLUGS HEAVILY COATED

Heavy, easily flaked off deposits on the side electrode and shell are usually the result of "scavenger additives" used in certain brands of fuel. Replace the plugs.



REV. 11-76

ONE OR TWO PLUGS SPLASH FOULED

Some plugs in a relatively new set may have splashed deposits. This occurs after a long delayed tune-up. Accumulated cylinder deposits are thrown against the plugs at engine operating speeds. Clean and reinstall these plugs.



CHIPPED INSULATOR

Chipped insulators on spark plugs are most likely the result of severe detonation. Bending the center electrode during gapping can also cause the insulator to crack. Replace these spark plugs and check the engine for over advanced timing.



MECHANICAL DAMAGE

A broken insulator and bent electrodes can result from foreign objects falling into the combustion chamber. Because of valve overlap, objects can travel from one cylinder to another. Always clean out the cylinders to prevent this recurrence.



"QUESTION MARK" SIDE ELECTRODES

Improper use of pliers type gap tools will bend the side electrode and push the center electrode into the insulator assembly.



SECTION 11. GOVERNOR SYSTEM

GENERAL	11-1
CHECKING GOVERNOR OPERATION	11-1
REPAIRING THE GOVERNOR	11-2
GOVERNOR ADJUSTMENT	11-4
AK, AJ Generator Sets	11-4
Adjusting Governor (Battery Charging Unit)	11-4
Automatic Idle Adjustment	11-4
LKB Generator Set, LK Engines	11-5
Speed Adjustment	11-5
Sensitivity Adjustment	11-5
Governor Spring	11-6
Throttle Stop Adjustment	11-6
CCK, MCKK and NH Generator Sets	11-6
Vacuum Speed Booster	11-6
GOVERNOR ADJUSTMENT	11-6
Linkage	11-8
Speed Adjustment	11-8
Sensitivity Adjustment	11-8
Vacuum Booster Adjustment	11-8
NB Governor Adjustment	11-8
NB Welder Governor System	11-9
Linkage	11-9
Procedure	11-9
Speed Adjustment	11-9
JB, JC, DJB, DJC, MDJB, MDJC, MDJE and MDJF Engine Governor Systems	11-10
Maintenance	11-10
Adjustments	11-10
Speed Adjustment (Prior to Spec R)	11-10
Sensitivity Adjustment (Prior to Spec R)	11-10
Speed Adjustment (Begin Spec R)	11-11
Sensitivity Adjustment (Begin Spec R)	11-11
DJA, MDJA Governor System	11-13
RJC, RDJC, RDJF Governor Adjustment	11-13

CCK Industrial Engine Governor System	11-14
Linkage	11-14
Speed Adjustment	11-14
Sensitivity Adjustment	11-14
Throttle Stop Screw	11-15
Variable Speed Governor Adjustment	11-15
Two Speed Governor	11-16
Constant Speed Governor.....	11-17
CCKA Tractor Governor Adjustment	11-17
Low Speed Adjustment	11-17
CCKB TRACTOR GOVERNOR	11-17
Low Speed Adjustment	11-17
High Speed Adjustment	11-18
Cleaning	11-18
High Speed and Cable Adjustment	11-18
CCKB Constant Speed Governor	11-19
NH, NHA, NHB, NHC Industrial Engine Governor Adjustment	11-20
Linkage	11-20
Speed Adjustment	11-20
Sensitivity Adjustment	11-20
Variable Speed Governor Adjustment	11-20
BF Tractor Governor	11-21
BF Welder Governor Adjustments	11-22
Linkage	11-22
Speed Adjustment	11-23
BF/NH POWER DRAWER GOVERNOR ADJUSTMENT	11-23
Linkage	11-23
Speed Adjustment	11-23

GENERAL

The governor system automatically regulates engine speed as selected by the throttle, regardless of load conditions. Onan engines use a standard flyball governor on the camshaft gear of the engine.

Adjusting the throttle control for increased speed places additional tension on the governor control spring. The spring tension opens the throttle and the engine speeds up (Figure 11-1).

As engine speed increases, centrifugal force causes the flyballs (Figure 11-2) to extend outward. Doing this they push against the governor spool that rotates the governor arm. The governor arm rotation overcomes some of the spring tension and closes the throttle valve until the force against the throttle linkage equals the tension in the governor spring. The amount of fuel to air mixture is reduced and in this way the speed remains constant under various loads unless the throttle setting is changed.

If increased load is placed on the engine, it tends to slow down in speed. Centrifugal force is reduced on the flyweights and they recede. This reduces pressure on the governor linkage. Less tension on the spring allows the throttle valve to open proportionately, increasing engine horsepower without allowing the engine to decrease significantly in speed. Figure 11-3 shows a cutaway of a J-series engine identifying the flyballs and their relation to the governor shaft.

CHECKING GOVERNOR OPERATION

A delicate balance exists between the governor control and the governor flyballs. If the spring loses its tension, or if the governor parts wear, or any of the

control linkages become damaged or worn, the governor will not work properly.

Before checking the governor for faulty operation, see that all components of the engine are functioning properly. Then:

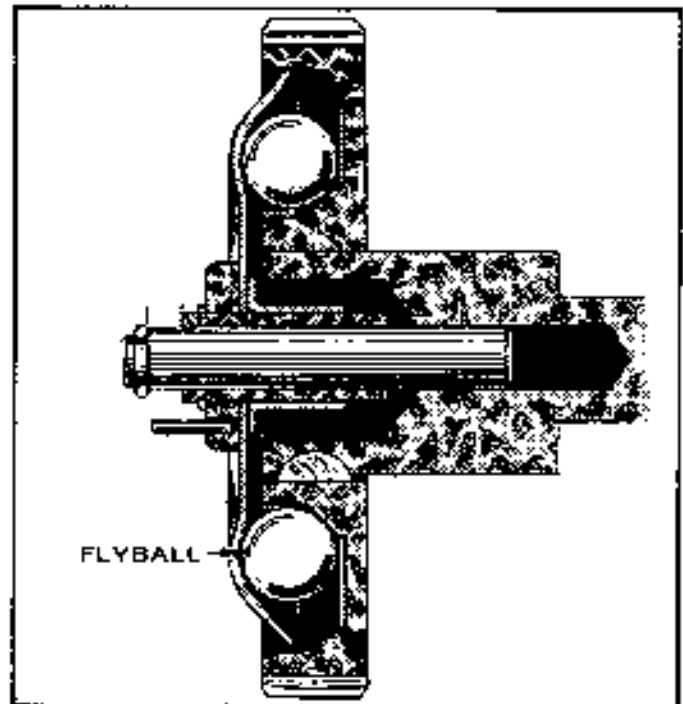

FIGURE 11-2. FLYBALLS

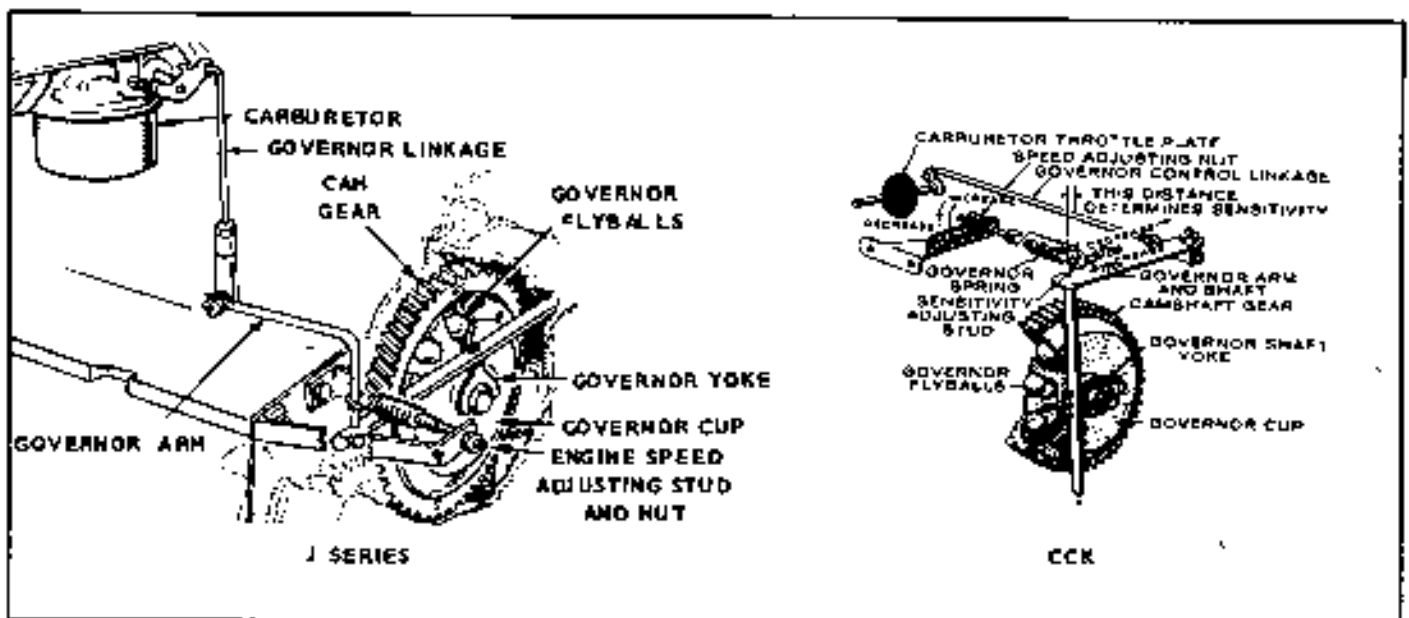

FIGURE 11-1. CENTRIFUGAL TYPE GOVERNORS

Rev 10-75

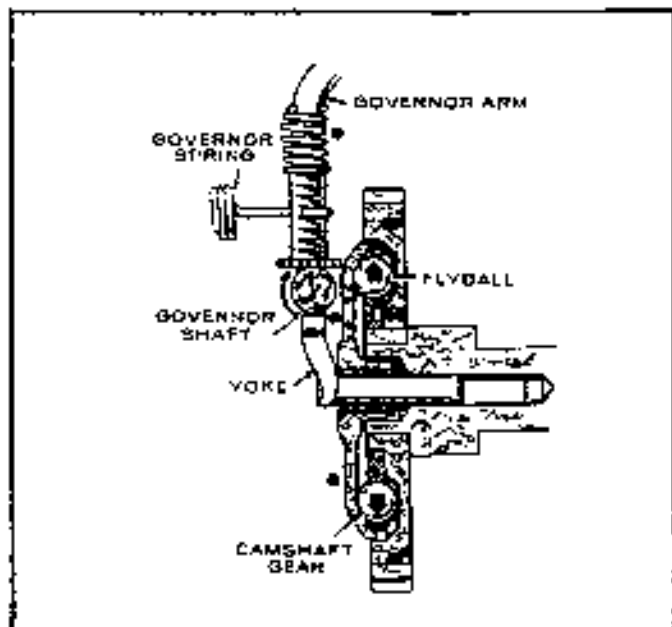

FIGURE 11-3. J SERIES CUTAWAY

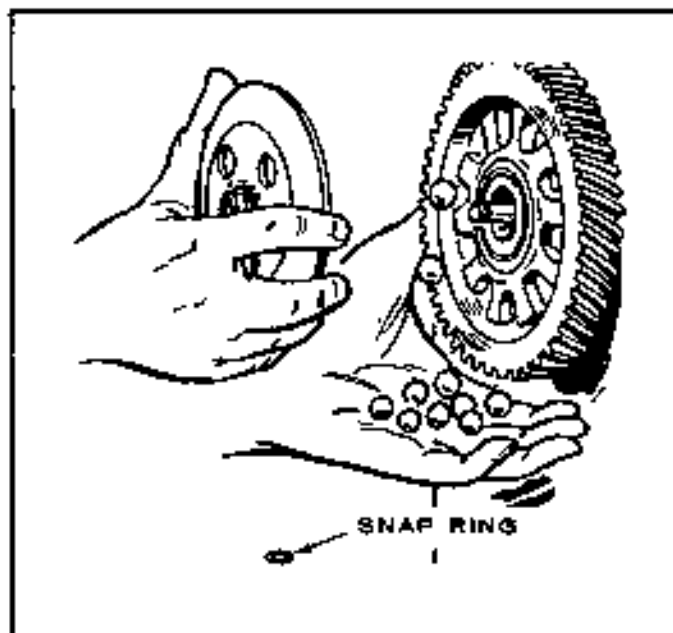

FIGURE 11-4. GOVERNOR CUP REMOVAL

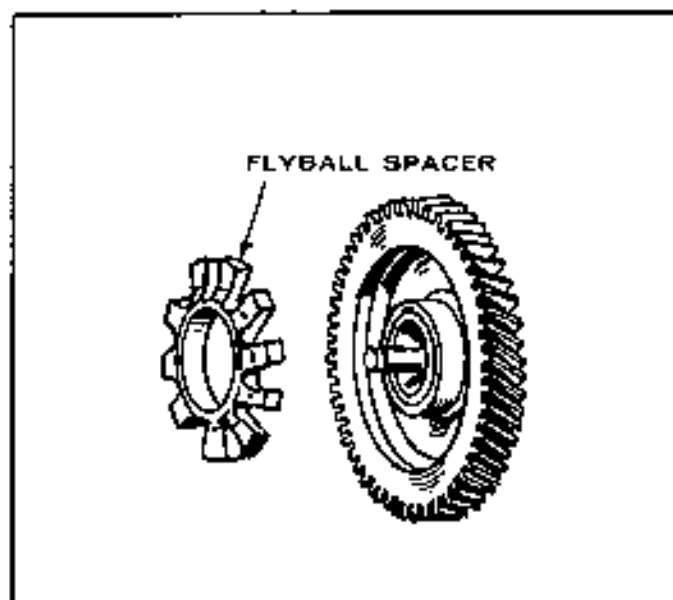

FIGURE 11-5. BALL SPACER

1. Check the condition of the governor linkage. Look for bent arm or worn connections. Check for free movement of the linkage.
2. Be sure the throttle valve is completely open when the engine is stopped.
3. Check the speed sensing portion of the system. Usually these parts give little trouble. If you have checked all other sources of trouble and still suspect the governor, follow the disassembly procedure in this section to reach the flyballs.
4. Check the recommended operating speed for the engine as listed on the nameplate of the unit. If the engine does not come up to speed, or surging occurs, or the engine overspeeds, follow the governor adjustment procedure in this section.

REPAIRING THE GOVERNOR

1. Disconnect and remove the governor linkage noting how to reassemble it. Draw a sketch or lay the parts out in the order of their disassembly. Figures 11-10 through 11-34 show many of the governor systems used on Onan engines.
2. Remove the engine gear cover.
3. Remove the snap ring that holds the governor cup to the camshaft gear (Figure 11-4). Be careful to catch the flyballs as the governor cup is removed.
4. Clean all governor parts thoroughly in a suitable solvent.
5. Replace with new parts any flyball that is grooved or has a flat spot; the ball spacer if its arms are worn or otherwise damaged (Figure 11-5) and the governor cup if its race surface is grooved or rough. The governor cup must have a free spinning fit on the camshaft center pin without excessive looseness or wobble.

6. When reinstalling the governor cup, tilt the engine so the gear is up. Equally space the flyballs on the gear, and install the cup and snap ring on the camshaft center pin (Figure 11-6).
7. On CCK engines the center pin extends out 3/4 inch (19.05 mm) from the end of the camshaft (25/32-inch [19.84 mm] on J-series engines). See Figure 11-7. This provides an in and out travel distance of 7/32 inch (5.56 mm) for the governor cup. Hold the cup against the flyballs when measuring. If the distance is less (the engine may race, especially at no load) remove the center pin and press a new pin in only the required amount. Otherwise grind off the hub of the cup as required.

CAUTION The camshaft center pin cannot be pulled outward nor removed without damage. If the center pin extends too far, the cup will not hold the flyballs properly.

8. Reinstall gear cover.
9. Reconnect governor linkage.
10. Adjust governor.

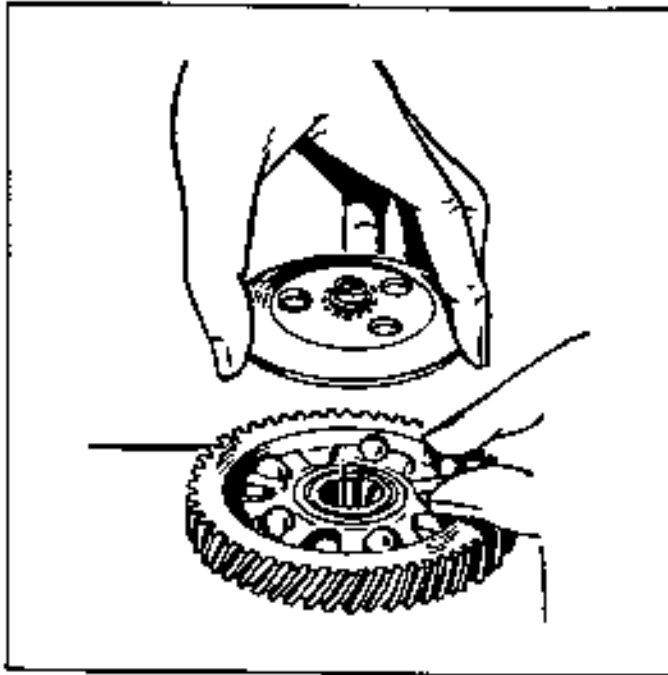

FIGURE 11-6. INSTALLING GOVERNOR CUP

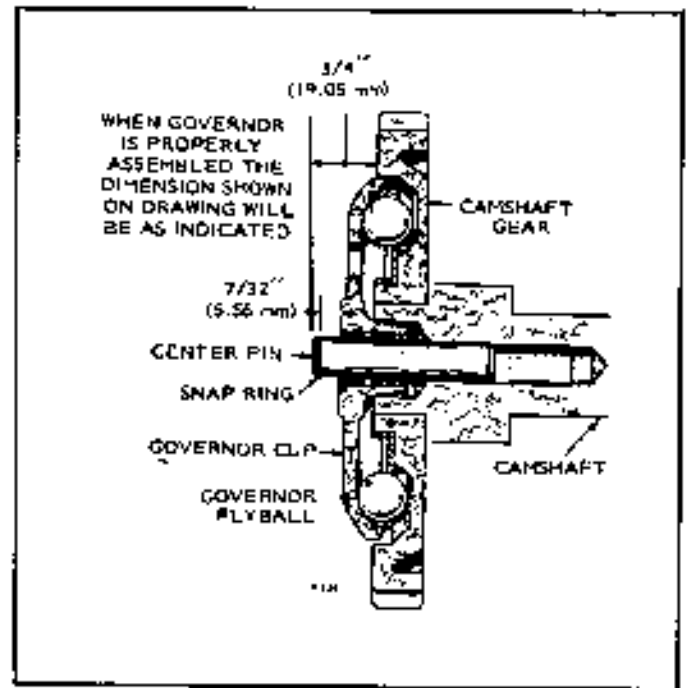

FIGURE 11-7. GOVERNOR CUP DETAILS

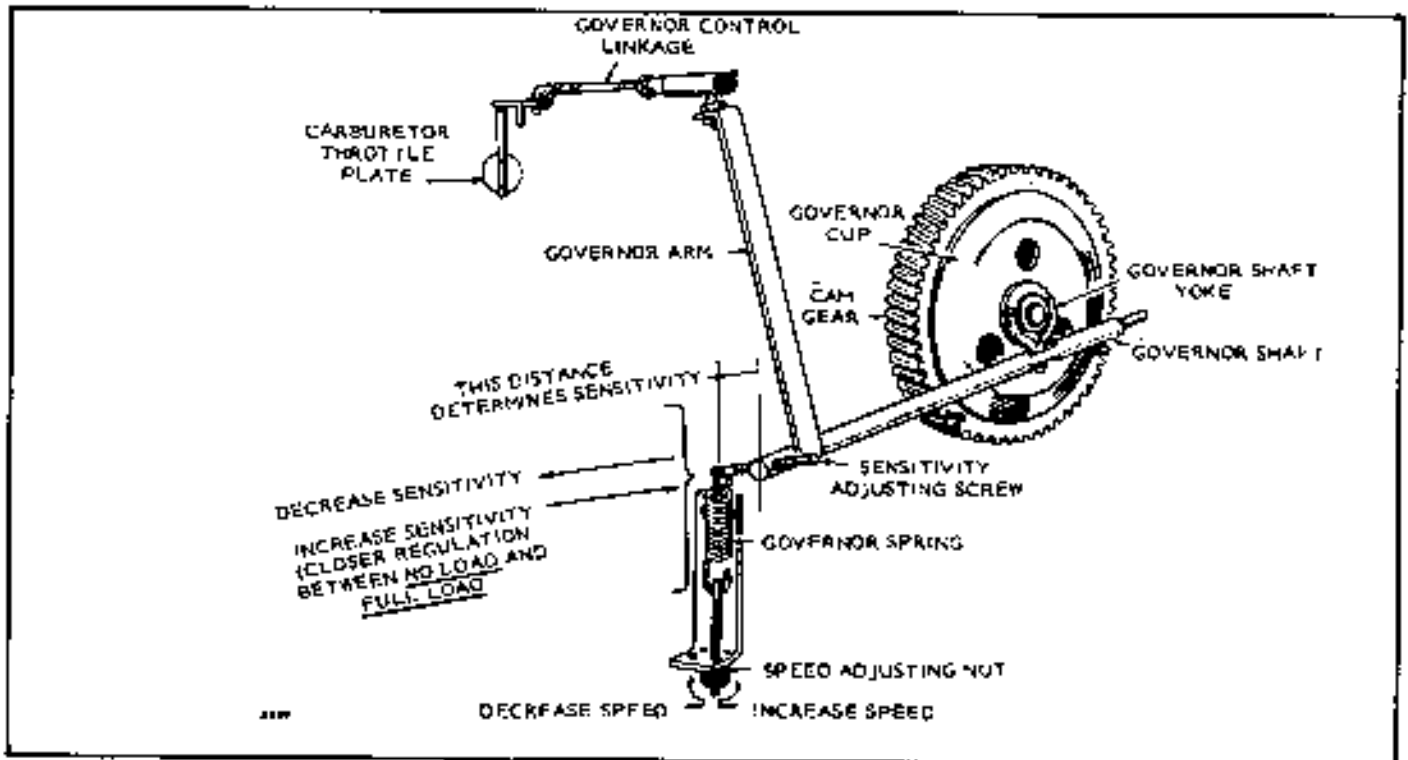

FIGURE 11-8. GOVERNOR ADJUSTMENTS

Rev 10-75

GOVERNOR ADJUSTMENT

Before making any governor adjustments, run the engine or generator set at light load until it reaches normal operating temperatures. On generator sets, engine speed determines voltage and frequency. Increased engine speed increases generator voltage and frequency, decreased engine speed decreases voltage and frequency. Use an accurate tachometer for adjusting the governor system on industrial engines. Connect a voltmeter or frequency meter (preferably both) to the generator output to correctly adjust generator set governors. Refer to the unit nameplate for all engine and generator set governor speed settings.

AK, AJ Generator Sets

Refer to Figure 11-8. Connect a voltmeter across the output of the governor. With no electrical load connected, adjust the speed adjusting nut to give a voltmeter reading of approximately 126 volts maximum for a 120 volt set. Apply a full rated electrical load. The voltage reading should be 108 volts or higher.

For 240 volt units, 252 volts at no load is maximum and 216 volts full load is minimum. The correct sensitivity adjustment gives the closest regulation without causing a hunting condition. If the voltage spread between no load and full load conditions is too great, move the end of the governor speed spring closer to the governor shaft. Test the governor action at various load conditions. If voltage regulation is good, but there is a tendency toward hunting at times, the sensitivity adjustment is too close or sharp. Turn the sensitivity stud outward slightly. Any change in sensitivity adjustment requires a speed readjustment.

When using a tachometer for adjusting the governor, engine speed at full load for a 60 hertz set should be approximately 1800 rpm for a 4-pole generator, or 3600 rpm for a 2-pole generator, with a spread of not more than 100 rpm between no load and full load for an 1800 rpm unit (200 rpm for a 3600 rpm unit). Engine speed at full load for a 50 hertz set should be approximately 1560 rpm for a 4-pole generator, or 3000 rpm for a 2-pole generator.

Adjusting the Governor (Battery Charging Unit): To adjust the governor on battery charging generators, turn the knurled speed adjusting nut (spring tension nut) to give the desired charge rate. The rate of charge is shown on the control box ammeter. The ability of the governor to keep the charge rate steady at the desired rate depends upon the distance between the center of the governor arm shaft and the governor arm end of the spring. If the governor tends to "hunt," or alternately increase and decrease speed, turn the sensitivity adjusting stud outward to move the end of the spring slightly away from the center of the governor shaft. Any change in the sensitivity adjustment will require a compensating change in the speed

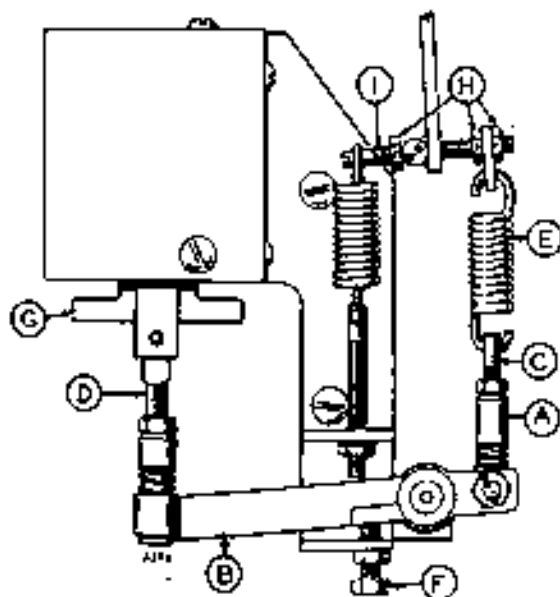

FIGURE 11-9. AUTOMATIC IDLE ADJUSTMENT

(spring tension) adjustment. Increasing sensitivity results in a slight decrease in engine speed. The desired adjustment is a setting that gives the closest regulation without hunting. Maximum speed at full load operation of battery charging units is approximately 2400 rpm, as specified on the nameplate.

Automatic Idle Adjustment

Some 3600 rpm models have a special idle device to drop engine speed to approximately 1800 rpm when the unit is operating at no load. The idle device automatically restores operating speed when an electrical load (100 watts or more) is connected.

Refer to Figure 11-9. Temporarily disconnect the flexible joint A from the lever B. The socket part slips off the ball part. Snap the idler switch on the outlet box to its OFF position. Adjust the governor for normal 3600 rpm operation under no load to full load conditions, with nuts H loosened. Tighten lock nuts H, with spring E as close to the end of the sensitivity screw as possible. Reconnect joint A to lever B. Turn stop adjusting screw F down for maximum lever movement.

Snap the idler switch to its ON position. With all electrical load removed, the solenoid should pull up and provide sufficient tension on spring E to override the tension of the regulating governor spring and reduce the engine speed to about 1800 rpm. If idle speed is too high, linkage C or D is too long. If idle speed is too low, linkage C or D is too short. With a full electrical load connected, the solenoid plunger should drop downward. Adjust screw F to just provide no tension on spring E, but without the spring being too loose. Be sure all lock nuts are tightened.

CAUTION

Never operate the set with the solenoid plunger G removed or unable to close completely, unless the control toggle switch is at its OFF position.

LKB Generator Set, LK Engines

The linkage and the position of the governor arm must synchronize the travel of the governor and the throttle plate so that the governor is in the wide open position when the throttle plate is in its wide open position and the governor is at its closed position when the throttle plate is at its closed position.

At wide open position, the lever on the throttle shaft should just touch the carburetor body or clear it by no more than 1/32 inch (0.79 mm). Change the length of the connecting linkage as necessary to obtain this setting by turning the ball joints on the threads of the link (Figure 11-10).

Speed Adjustment: The setting of the speed adjusting screw (Figure 11-10) determines the speed at which the engine operates. Connect a voltmeter or frequency meter (or use a tachometer if these are not available) to the output of the generator. Start the engine and allow it to warm up. Set the engine speed according to the nameplate.

Sensitivity Adjustment: The correct sensitivity adjustment gives the closest regulation without causing a hunting condition. If the voltage spread between no load and full load conditions is too great, move the end of the governor speed spring closer to the governor shaft. Test the governor action at various load conditions. If voltage regulation is good but there is a tendency toward hunting at times, the sensitivity adjustment is too close or sharp. Turn the sensitivity stud outward slightly. Any change in the sensitivity adjustment will require a speed readjustment.

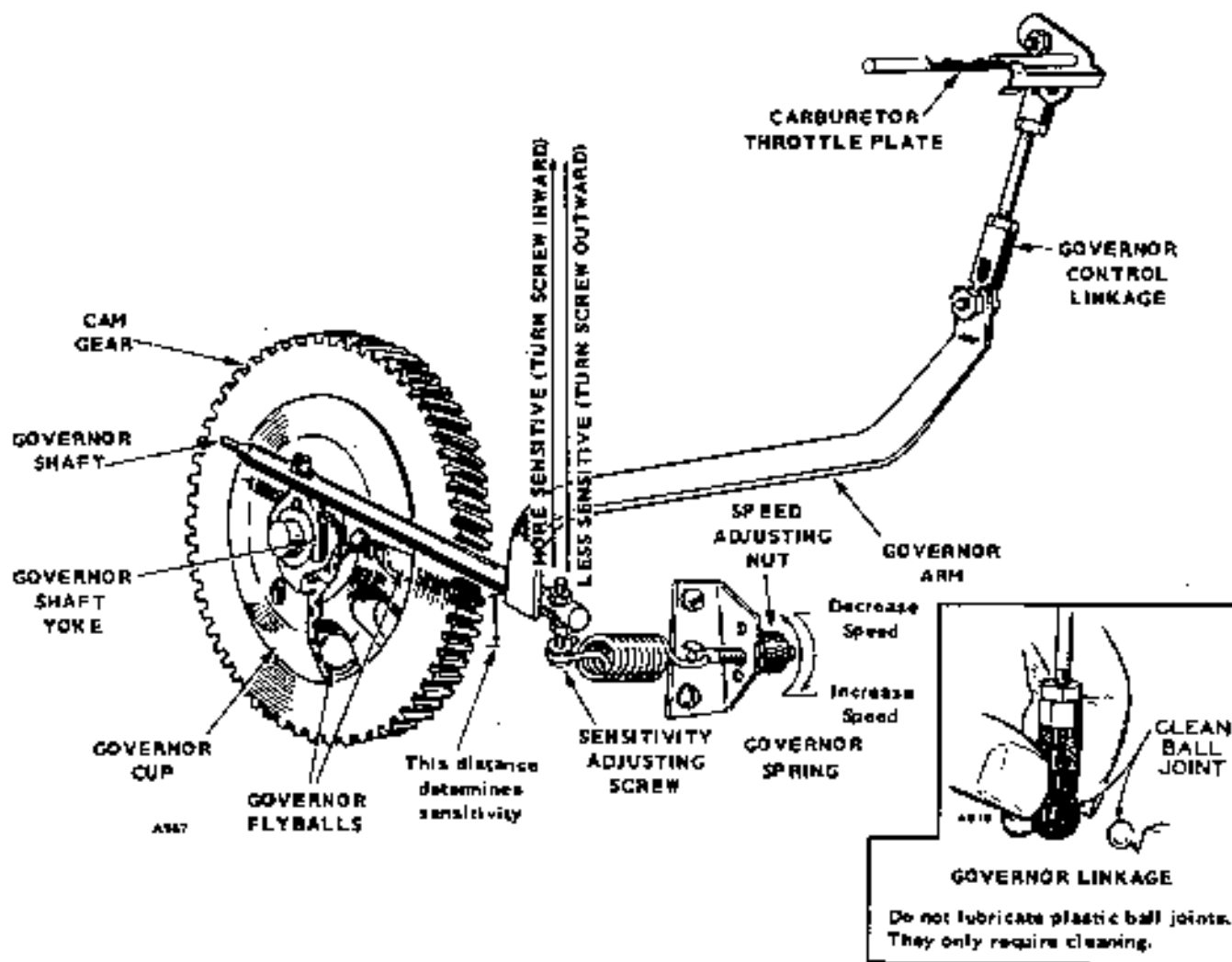

FIGURE 11-10. GOVERNOR ASSEMBLY

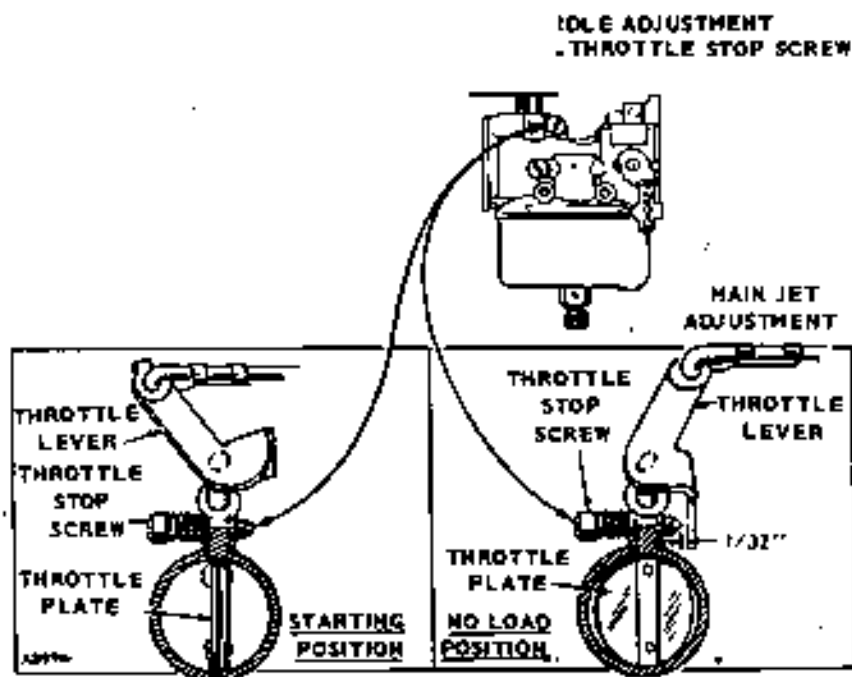

FIGURE 11-11. THROTTLE STOP ADJUSTMENT

Governor Spring: Springs become fatigued and lose their calibrated tension from long usage. Sometimes it is necessary to replace the governor spring to get proper regulation. It is difficult to determine whether a spring is fatigued. Usually, if all other adjustments have been properly made and the regulation is still erratic, replacing the governor spring and resetting the sensitivity and speed adjusting screws will correct the trouble.

Throttle Stop Adjustment: See Figure 11-11 for the throttle stop adjustment procedure.

CCK, MCCK and NH Generator Sets

The governor arm fastens to a shaft extending from the gear cover and connects by a ball joint and link to the carburetor throttle arm (Figure 11-12). Flyballs behind the cup on the camshaft gear actuate the governor arm. If the carburetor has been removed or the governor disassembled, readjust the governor.

Vacuum Speed Booster

Some generator sets have vacuum speed boosters. The vacuum booster is a separate auxiliary device that supplements the governor. As the generator load increases, the booster helps the governor by producing a slight increase in engine speed. This results in nearly a constant output voltage.

Engine vacuum actuates the booster which is mounted on the intake manifold. When the unit is

operating at half load or less, engine vacuum is sufficient to enable the diaphragm to overcome the internal booster spring tension. Under these conditions, the booster external spring is under no tension and the booster does not affect the governor action.

As the unit load increases, engine vacuum decreases. The booster internal spring tension overcomes the pull of the diaphragm and tension is put on the booster external spring. This tension helps the regular governor spring in its function by causing a slight increase in engine speed as the load is increased.

GOVERNOR ADJUSTMENT

The governor and vacuum booster control engine speed. See Figure 11-12. Rated speed and voltage appear on the unit nameplate. The engine speed on a 4-pole generator unit equals the frequency times 30. This means a 60 hertz unit must turn at 1800 rpm. The governor should not allow more than 2-1/2 hertz change from no load to full load.

1. Adjust the carburetor main jet for best fuel mixture while operating the unit with a full rated load.
2. Adjust the carburetor idle needle under no load condition.
3. Adjust the length of the governor linkage.
4. Check the governor linkage and throttle shaft for binding or excessive looseness.

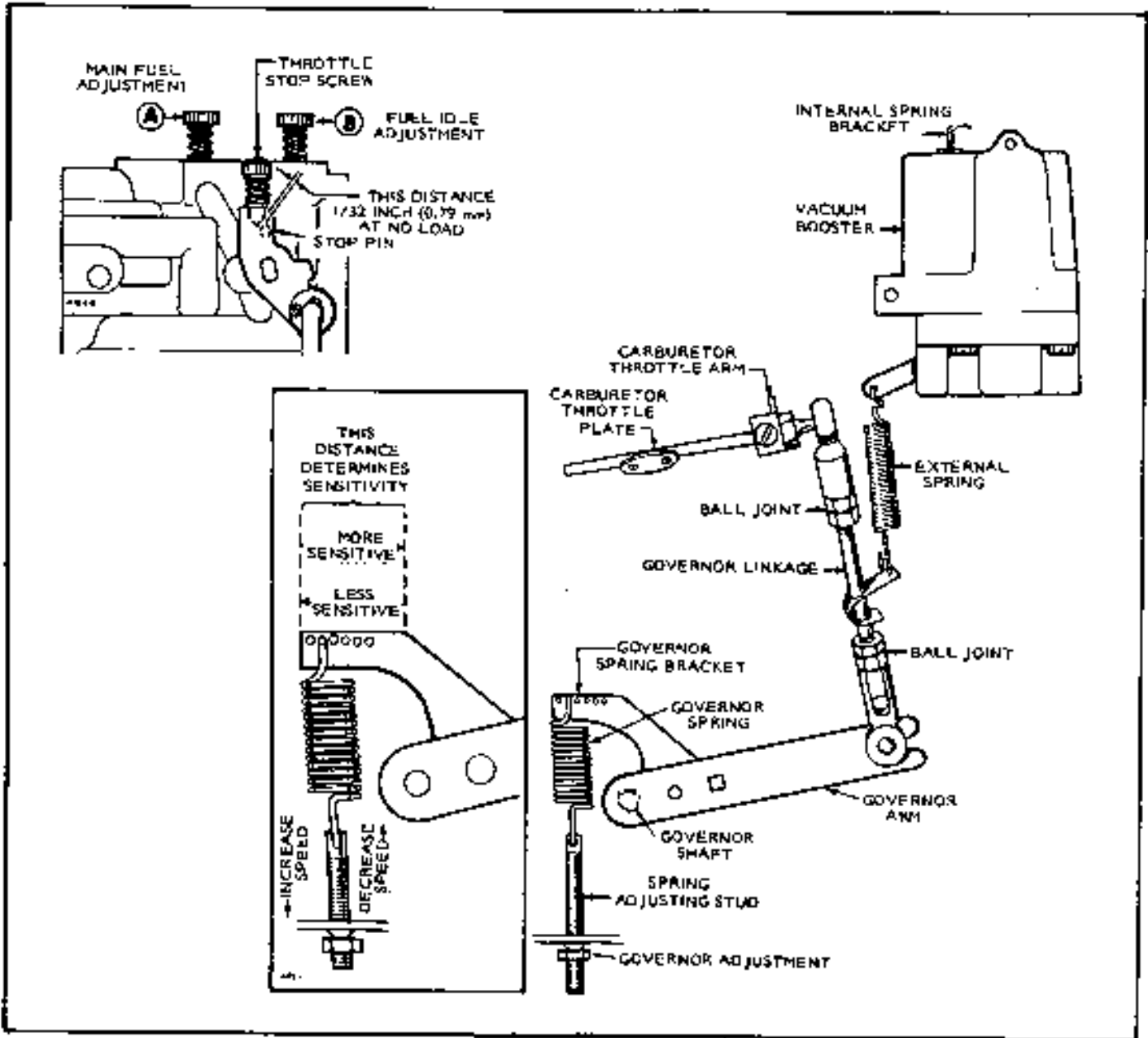

FIGURE 11-12. OCK, MCK, NH GOVERNOR ADJUSTMENTS

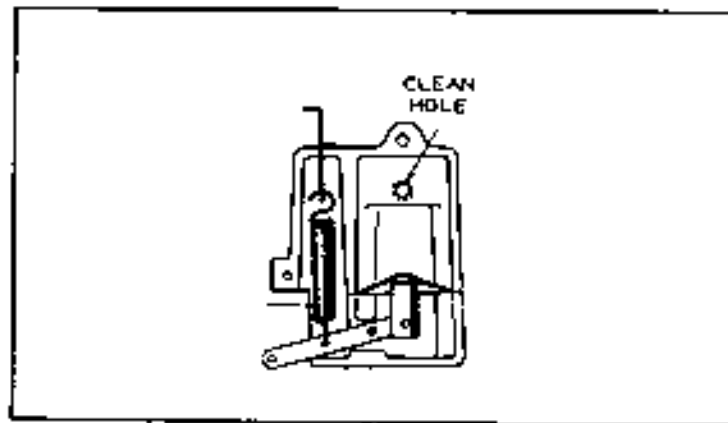

FIGURE 11-13. CLEANING SPEED BOOSTER

5. Adjust the governor spring tension for rated speed at no load operation with the booster disconnected (or held inoperative).
6. Adjust the governor sensitivity.
7. Check the speed adjustment.
8. Set the carburetor throttle stop screw.
9. Set the vacuum speed booster.

Linkage: Adjust the length of the linkage connecting the governor arm to the throttle arm by rotating the ball joint. Adjust the length so that with the engine stopped and the governor arm held in the closed throttle position, the stop screw on the carburetor throttle lever is 1/32 inch (0.79 mm) from the stop pin. This setting allows immediate control by the governor after starting and synchronizes travel of the governor arm and throttle shaft.

Speed Adjustment: With the warm-up unit operating at no load and with the booster external spring disconnected, adjust the governor spring tension. Turn the speed adjusting nut to obtain voltage and speed readings within the limits shown on the unit nameplate.

Sensitivity Adjustment: Check the voltage and speed with no load connected and then with a full load. Adjust the sensitivity to give the closest regulation (least speed and voltage difference between no load and full load) without causing a hunting condition.

To increase sensitivity (closer regulation), move the governor spring toward the governor shaft. Adjusting for too much sensitivity causes hunting. To decrease sensitivity, move the governor spring toward the outer end of the governor arm. Too little sensitivity results in too much difference in speed between no load and full load conditions.

Any change in the sensitivity adjustment usually requires a compensating speed (spring tension) adjustment.

On marine units, make all final governor adjustments with the flame and resonator mounted on the carburetor.

Vacuum Booster Adjustment

Adjust the booster after satisfactory performance under various load conditions has been obtained by governor adjustments without the booster.

Connect the booster external spring to the bracket on the governor link. With the unit operating at no load, slide the bracket on the governor link just to the position where there is no tension on the external spring. Apply full load and observe booster action. To increase or decrease response, change the cotter pin to another hole in the return spring strap. The booster is correctly adjusted when the speed does not drop more than 4 cycles with a sudden load application and recovers rapidly. Tighten the hold-down screw of the booster at each tune-up.

Using a fine wire, clean the small hole in the short vacuum tube that fits into the hole in the top of the engine intake manifold (Figure 11-13). Do not enlarge this hole. If there is tension on the external spring when the unit is operating at no load or light load, the booster may be improperly adjusted, the hole in the small vacuum tube may be restricted or the booster diaphragm or gasket may have a leak.

NB Governor Adjustment

Figure 11-14 illustrates the governor adjustment procedure for the NB generator set and industrial engine.

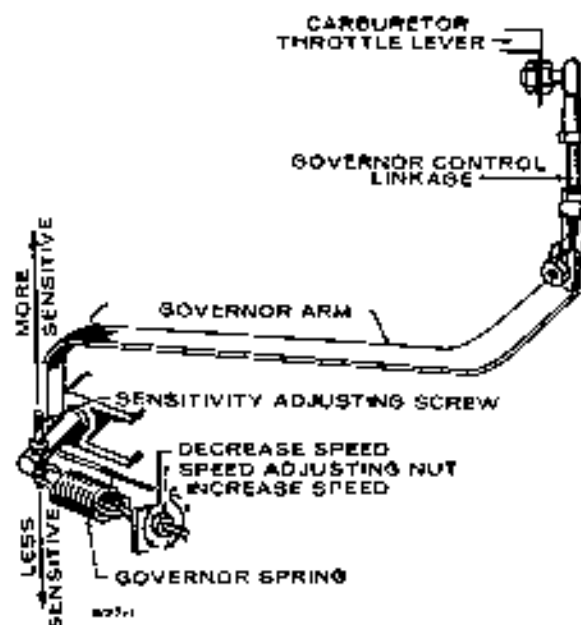

FIGURE 11-14. NB GOVERNOR ADJUSTMENT

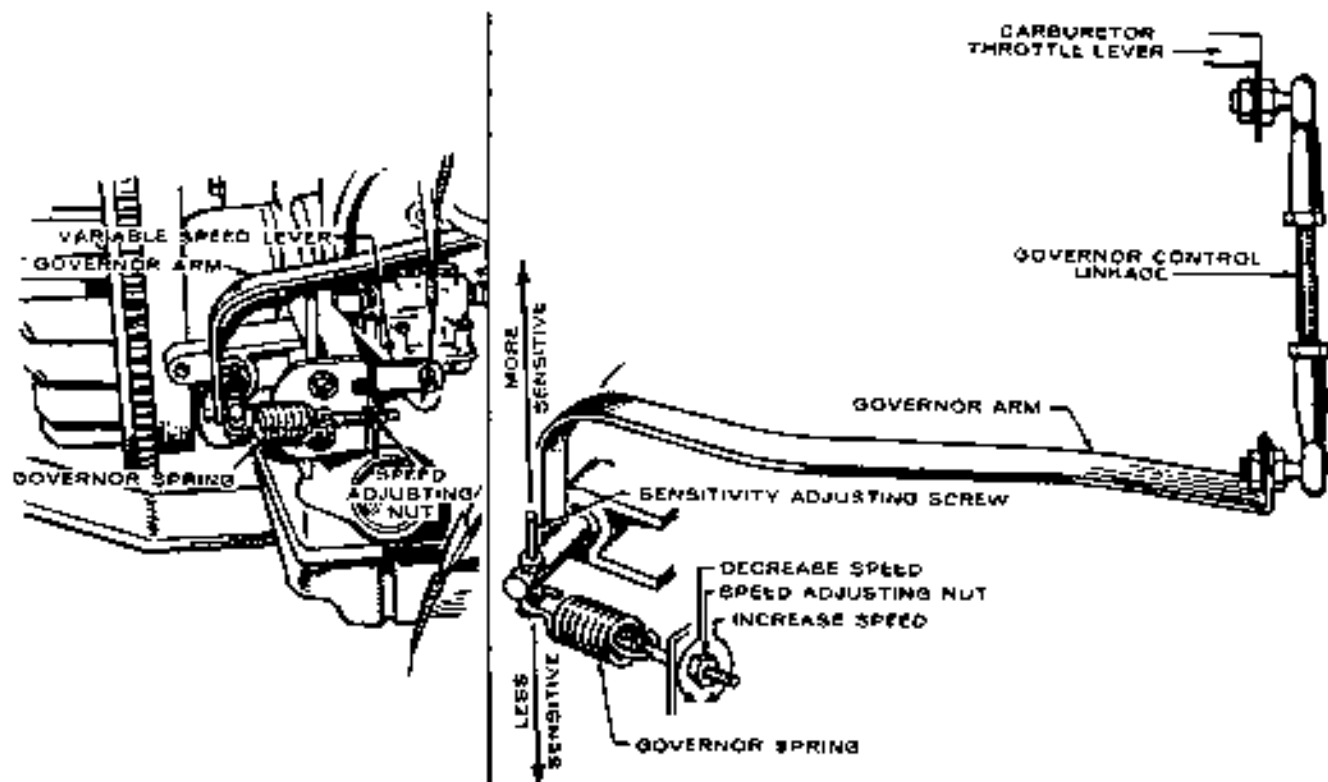

FIGURE 11-15. NB WELDER GOVERNOR ADJUSTMENT

NB Welder Governor System

Check the governor arm, linkage, throttle shaft and lever for binding condition or excessive slack and wear at connecting points. A binding condition at any point will cause the governor to act slowly and regulation will be poor. Excessive looseness will cause a hunting condition and regulation will be erratic. Work the arm back and forth several times by hand while the engine is idling. If either of these conditions exists, find where the trouble is and adjust or replace parts as needed.

Before making governor adjustment, allow the engine to reach normal operating temperature. If the engine is being run with the throttle wide open, either the governor is not properly adjusted or the engine is overloaded. After long usage, the governor spring may have become fatigued. If the regulation is still erratic after properly making all other adjustments, install a new spring (Figure 11-15).

Linkage: The engine starts at wide open throttle. Adjust the length of the linkage connecting the governor arm to the throttle arm by rotating the ball joint. Adjust length so that with the engine stopped and tension on the governor spring, the stop screw on the carburetor throttle lever is 1/32 inch (0.79 mm) from stop pin. This setting allows immediate control by the governor after starting and synchronizes travel of the governor arm and the throttle shaft.

Procedure:

1. Adjust the carburetor main jet for the best fuel mixture at full load operation.
2. Adjust the carburetor idle needle with no load connected.
3. Adjust the length of the governor linkage
4. Check the governor linkage and throttle shaft for binding or excessive looseness.
5. Adjust the governor spring tension for nominal engine speed at no load operation.
6. Check the rpm drop between no load and full load operation and adjust the governor sensitivity as needed
7. Recheck the speed adjustment.
8. Set the carburetor throttle stop screw.

Speed Adjustment: Approximately 3000 rpm is the recommended maximum full load speed for continuous operation. The speed must agree with the load requirements

Tension applied to the governor spring determines engine speed. Increasing spring tension increases engine speed. Decreasing spring tension decreases engine speed. The no load speed of the engine should be slightly higher than the speed requirements of the connected load.

If a speed adjustment is needed, turn the speed adjusting nut in to increase the speed or out to decrease the speed (Figure 11-15).

Adjust the tension of the governor spring for minimum speed. Adjust the throttle linkage so that shifting of the throttle speed lever will give a desired range of speeds. First, shift the lever to minimum (slow) position and with no load connected, adjust the spring tension for about 800-1000 rpm.

Adjust the sensitivity while operating at minimum speed to attain the smoothest no load to full load operation as follows:

The sensitivity of the governor depends upon the position of the arm end of the governor spring. A threaded stud on the governor arm provides for adjustment. To increase sensitivity, move the governor spring toward the governor shaft by loosening the upper locknut on the threaded stud and tightening the lower nut. To decrease sensitivity, reverse the procedure.

A too sensitive setting will result in a surging speed (hunting) condition, an alternate increase and decrease in engine speed. An opposite setting will result in too much speed variation between no load and full load conditions. Thus, the correct position of the governor spring will result in the most stable speed regulation without causing a surge condition.

Always recheck the speed adjustment after a sensitivity adjustment. Increasing sensitivity will cause a slight decrease in speed and will require a slight increase in the governor spring tension.

Adjust the throttle stop screw on the carburetor to allow a recommended minimum idling speed of 800-1000 rpm. (A lower minimum does not assure smooth operation under load.)

JB, JC, DJB, DJC, MDJB, MDJC, MDJE and MDJF Engine Governor Systems

The governor system controls engine speed with and without load. The system consists of a governor cup with steel flyballs on the camshaft, a yoke, shaft and arm; governor spring and adjusting screw; and linkage to the carburetor.

Variations in engine speed changes the position of the governor cup on its shaft. This change is transmitted by the shaft, arm and linkage to the carburetor throttle lever. Tension on the governor spring determines engine speed. The number of spring coils used controls sensitivity (speed drop from no load to full load). More coils give less speed drop from no load to full load (greater sensitivity).

Maintenance

Periodically lubricate the metal governor linkage with lubricating graphite or light non-gumming oil. Also, inspect the governor linkage for binding or excessive slack or wear.

Adjustments

Prior to Spec R, both the governed speed and the governor sensitivity are adjusted with the stud and nut on the front of the engine air housing (Figure 11-16). Beginning Spec R, the sensitivity is adjusted with an adjusting ratchet.

Speed Adjustment (Prior to Spec R): To adjust the governed speed, hold the governor spring stud in position and turn the governor spring nut with a wrench. For accurate speed adjustment, use a reed frequency meter on the unit's AC output. (A mechanical tachometer is not as accurate.) On generator sets set frequency and speed according to the nameplate.

Sensitivity Adjustment (Prior to Spec R): To adjust the sensitivity, turn the governor spring stud; counterclockwise gives more sensitivity (less speed drop). If the governor is too sensitive, a hunting condition occurs (alternate increasing and decreasing speed). Adjust for maximum sensitivity without hunting. See the engine nameplate for speed and sensitivity settings. After sensitivity adjustment, the speed may require readjustment.

Speed Adjustment (Begin Spec R): Adjust engine speed by turning governor speed adjusting nut (Figure 11-16). Turn nut clockwise to increase speed, counterclockwise to decrease speed.

Sensitivity Adjustment (Begin Spec R): Adjust sensitivity (no load to full load speed drop) by turning the sensitivity adjusting ratchet nut, accessible through hole in side of blower housing. If speed drops too much when a full load is applied, turn the ratchet nut counterclockwise to increase spring tension and compensate for reduced rpm. An oversensitive adjustment, approaching no speed drop when load is applied, may result in hunting condition (alternate increase and decrease in speed).

After adjusting speed and sensitivity, replace dot button in blower housing (air cooled units only) and secure speed stud lock nut.

If the governor is either too sensitive or not sensitive enough and cannot be adjusted with the stud or ratchet, the sensitivity can be coarsely adjusted by changing spring attachment on the governor arm. Moving this point further from the governor shaft decreases the governor's sensitivity.

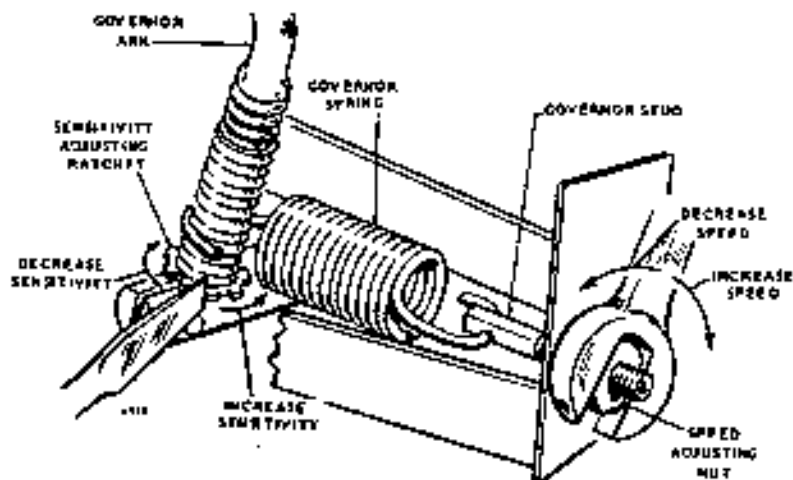
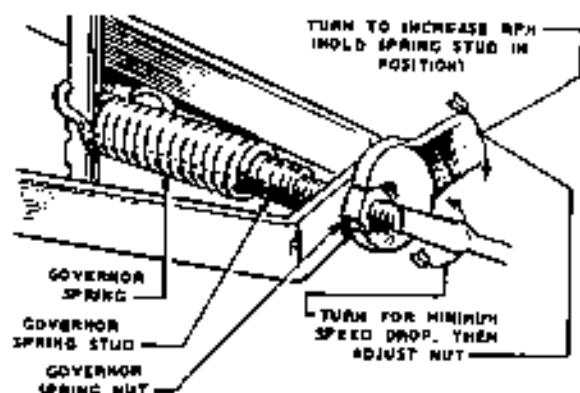
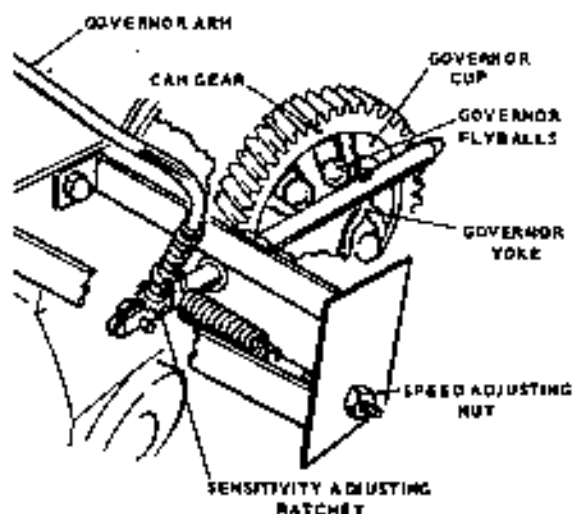

FIGURE 11-16. GOVERNOR ADJUSTMENTS

Standard spring only used for lowest speed. Auxiliary and standard springs are used for higher speeds.

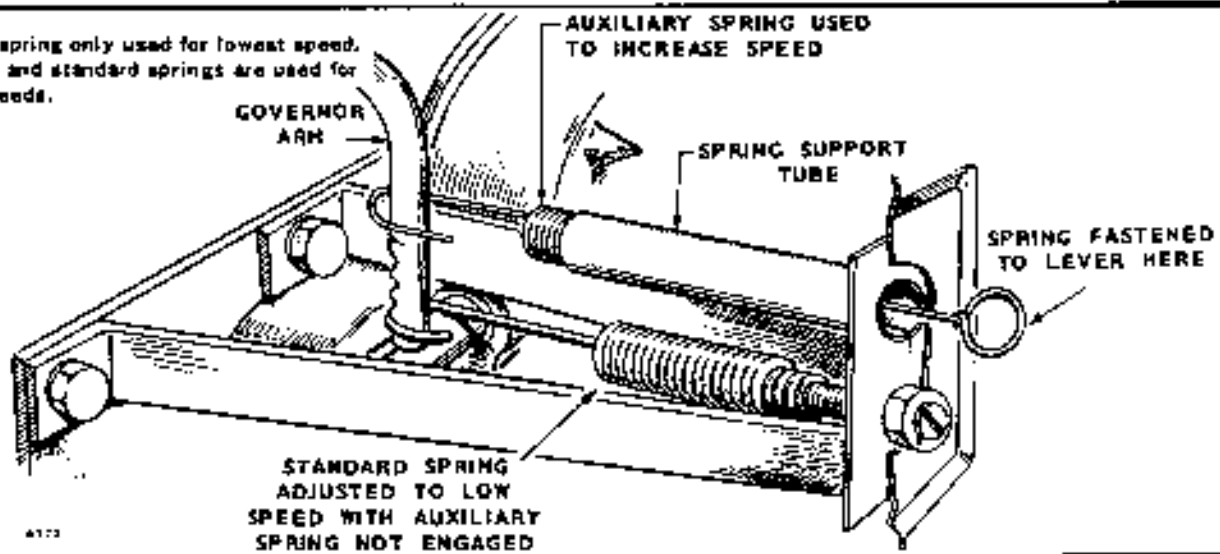

FIGURE 11-17. DJB, DJC VARIABLE SPEED GOVERNOR

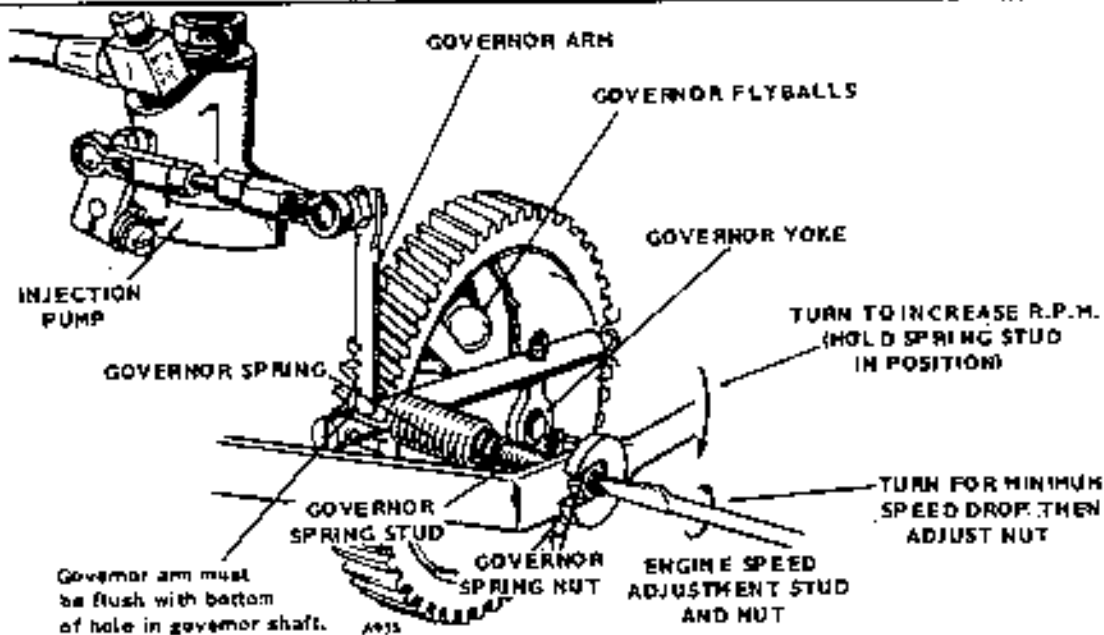

FIGURE 11-18. DJA GOVERNOR ASSEMBLY (PRIOR TO SPEC R)

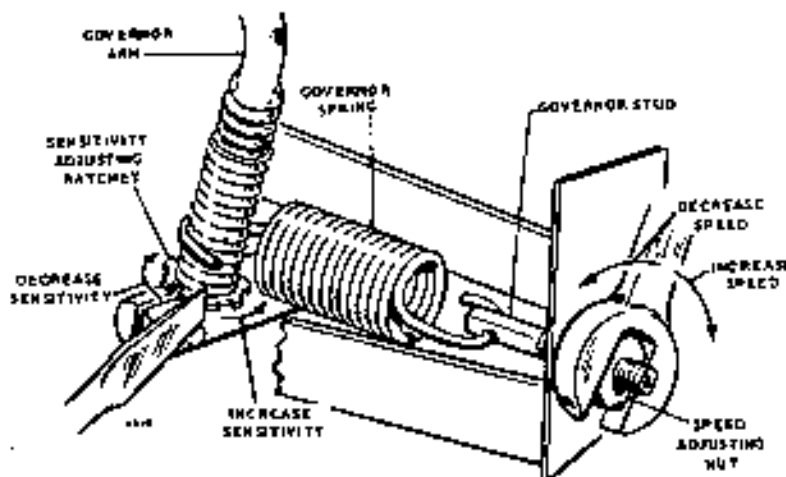

FIGURE 11-19. DJA GOVERNOR ADJUSTMENTS (SPEC R)

DJA, MDJA Governor System

Adjust engine speed by turning governor speed adjusting nut (Figure 11-18). Turn nut clockwise to increase speed, counterclockwise to decrease speed.

Adjust sensitivity (no load to full load speed drop) by turning the sensitivity adjusting ratchet nut accessible through hole in side of blower housing. If speed drops too much when full load is applied, turn the ratchet nut counterclockwise to increase spring tension and compensate for reduced rpm. An oversensitive adjustment, approaching no speed drop when load is applied, may result in a hunting condition (alternate increase and decrease in speed). Adjust for maximum sensitivity without hunting. The use of a

reed-type frequency meter will give the most accurate results. On generator sets, it should be possible to adjust for a sensitivity of less than 3 hertz, 2 hertz is usually attainable.

After adjusting speed and sensitivity, secure speed stud lock nut and replace dot button in blower housing (air cooled units only).

The governor cup disassembly and assembly is discussed earlier in this section.

RJC, RDJC, RDJF Governor Adjustment

Figure 11-20 illustrates the governor system adjustment procedure for the above generator sets.

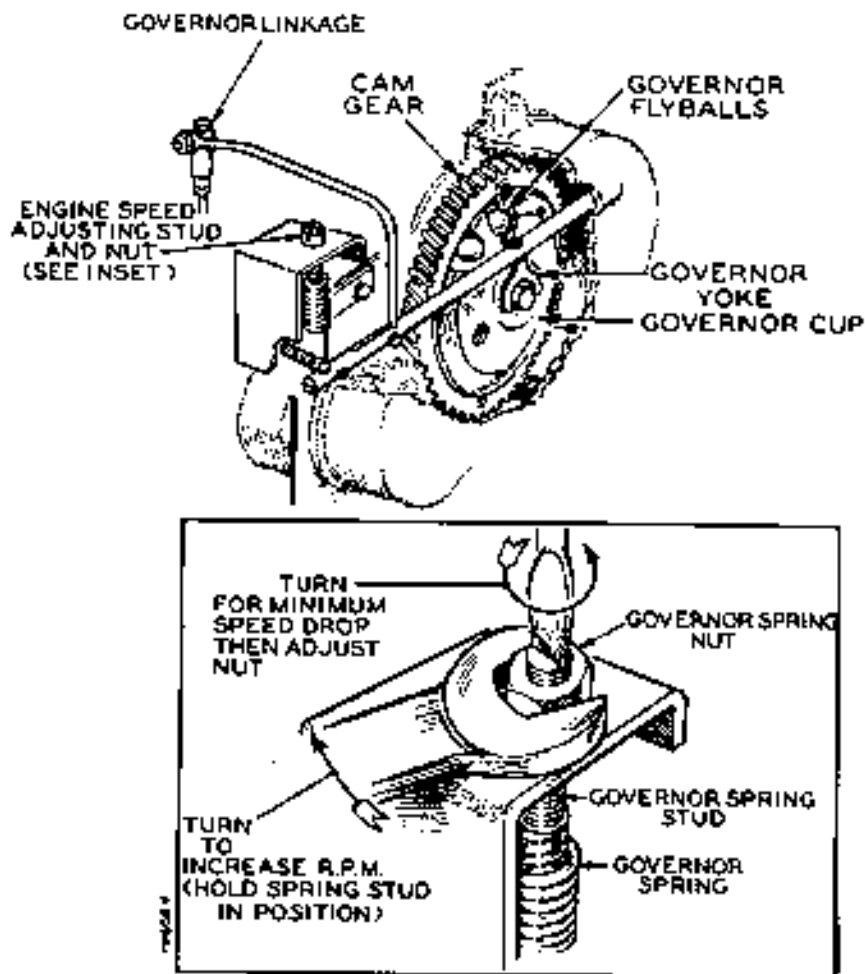

FIGURE 11-20. RJC, RDJC, RDJF GOVERNOR ADJUSTMENT (SPEC R)

CCK Industrial Engine Governor System

Where engine speed is governor controlled, the governor is set at the factory to allow a nominal engine speed of 2400 rpm at no load operation (unless another speed is specified when the engine is ordered).

If the engine is being run with the throttle wide open, either the governor is not properly adjusted or the engine is overloaded.

After long usage, the governor spring may have become fatigued. If the regulation is still erratic after properly making all other adjustments, install a new spring (Figure 11-21).

Check engine speed with a tachometer.

Check the governor arm, linkage, throttle shaft and lever for a binding condition or excessive slack and wear at connecting points. A binding condition at any point will cause the governor to act slowly and regulation will be poor. Excessive looseness will cause a hunting condition and regulation will be erratic. Work the arm back and forth several times by hand while the engine is idle. If either condition exists, find the trouble and adjust or replace parts as required.

Linkage: The engine starts at wide open throttle. Adjust the length of the linkage connecting the governor arm to the throttle shaft and lever by rotating

the ball joint. Adjust this length so that with the engine stopped and tension on the governor spring, the stop on the carburetor throttle shaft just contacts the underside of the carburetor bowl. This setting allows immediate control by the governor after starting. It also synchronizes the travel of the governor arm and the throttle shaft.

Speed Adjustment: Tension applied to the governor spring determines engine speed. Increasing spring tension increases engine speed. Decreasing spring tension decreases engine speed. The no load speed of the engine should be slightly higher than the speed requirements of the connected load. For example: If the connected load is to turn at 2310 rpm, set the no load speed of the engine at about 2400 rpm. Check speed with a tachometer.

If a speed adjustment is needed, turn the speed adjusting nut in to increase the speed or out to decrease the speed (Figure 11-21).

Sensitivity Adjustment: Engine speed drop from no load to full load must be within 100 rpm. Check the engine speed with no load connected and again after connecting a full rated load.

Governor sensitivity depends upon the position of the arm end of the governor spring. A sliding clip or grooved head stud on some models provides for adjustment. To increase sensitivity, shift the adjusting clip toward the governor shaft—or turn the adjusting

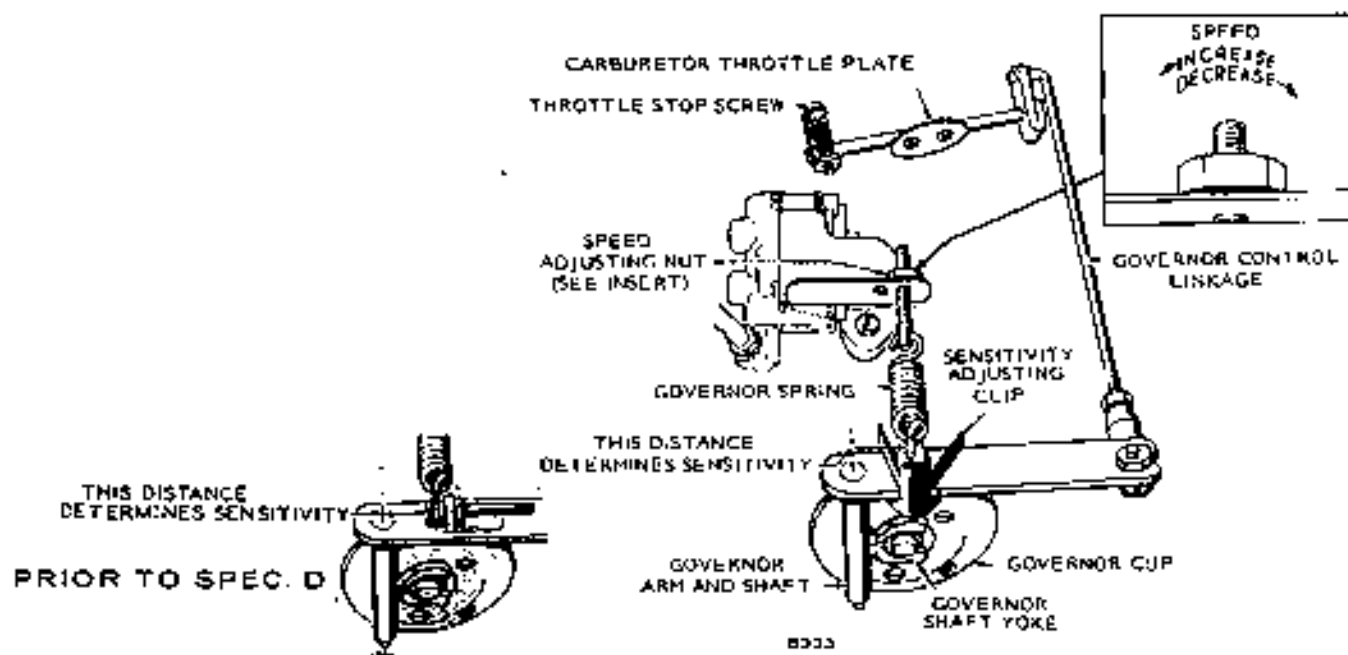

FIGURE 11-21. CCK GOVERNOR SYSTEM PRIOR TO SPEC D

stud clockwise. To decrease sensitivity, shift the adjusting clip toward the linkage end of the governor arm—or turn the adjusting stud counterclockwise.

Too sensitive a setting will result in a surging speed condition. An opposite setting will result in too much speed variation between no load and full load conditions. Thus, the correct position of the clip (or stud) will result in the most stable speed regulation without causing a surge condition.

Always recheck the speed adjustment after a sensitivity adjustment. Increasing sensitivity will cause a slight decrease in speed and will require a slight increase in the governor spring tension.

Throttle Stop Screw: The throttle stop screw should be set at 1/32 inch (0.79 mm) distance from the manifold when the engine is operating with no load connected (Figure 11-22).

Variable Speed Governor Adjustment: These engines are adapted for use where a wide range of speed settings is desired. Engine speed is controlled at any given point between minimum and maximum by simply adjusting the speed lever on the blower housing until the desired speed is reached.

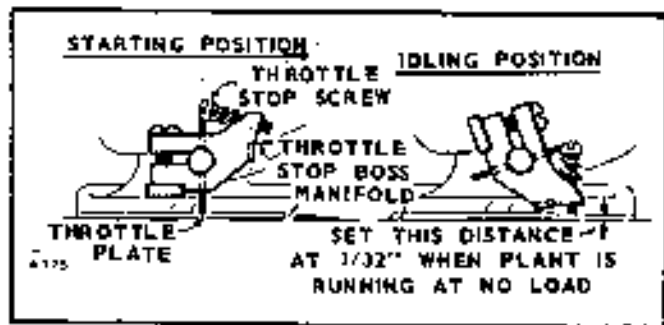

FIGURE 11-22. THROTTLE STOP SCREW

The variable speed governor design gives an automatic decrease in sensitivity when engine speed is increased resulting in good stability at all speeds.

To adjust the variable speed governor, refer to Figure 11-23 and the following:

1. Run the engine and make necessary carburetor adjustments
2. Adjust the throttle stop screw on the carburetor to a minimum idling speed of 1450 rpm so the governor spring can hold the engine speed at 1500 rpm. (A lower minimum does not assure smooth operation under load.)
3. Adjust governor spring tension for minimum speed. Shift the lever to the minimum (slow) position and with no load connected, adjust the spring tension for about 1500 rpm.
4. Adjust the sensitivity while operating at a minimum speed to attain the smoothest no load to full load operation as follows:

To decrease sensitivity (allow more speed drop from no load to full load operation): Move the governor spring outward to a different groove or hole in the extension (or on earlier models, turn the sensitivity screw outward) so that the point of pull by the spring is moved slightly away from the governor shaft.

To increase sensitivity (closer regulation by the governor that permits less speed drop from no load to full load operation): Move the governor spring inward to a different groove or hole in the extension (or on earlier models, turn the sensitivity screw inward) so that the point of pull by spring is moved slightly closer to the governor shaft.

5. Apply full load and shift the lever until the engine speed reaches the desired maximum speed. Set the screw in the bracket slot to stop lever travel at the desired maximum full load speed position. Approximately 3000 rpm is the recommended maximum full load speed for continuous operation. The speed must agree with the load requirements.

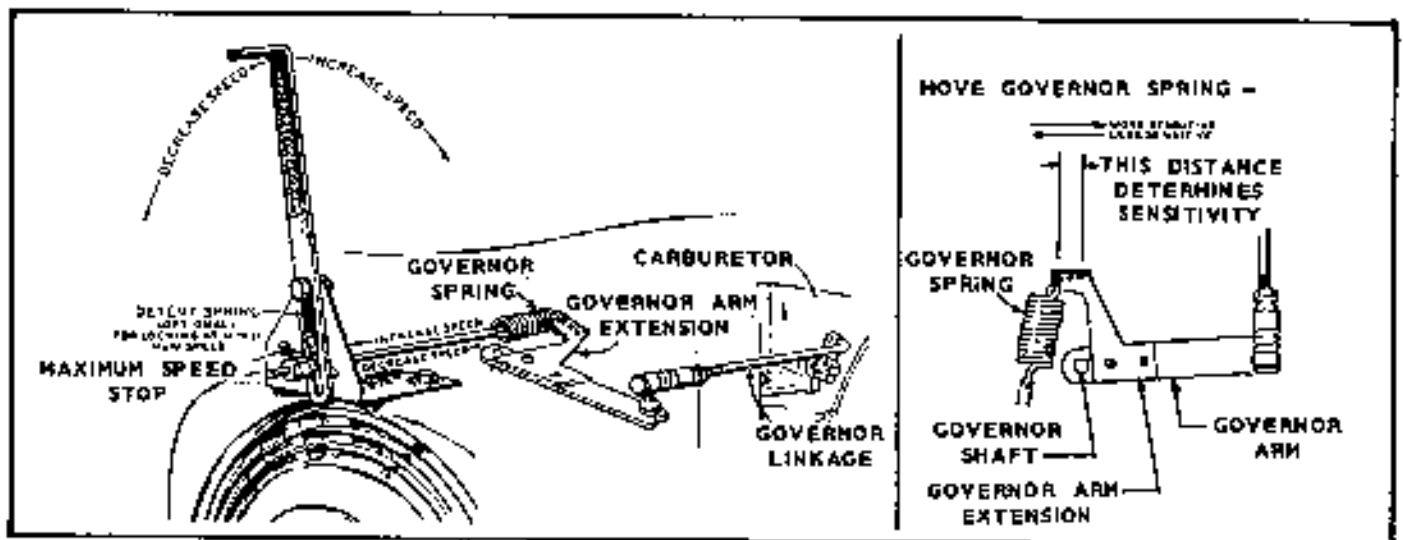

FIGURE 11-23. VARIABLE SPEED GOVERNOR

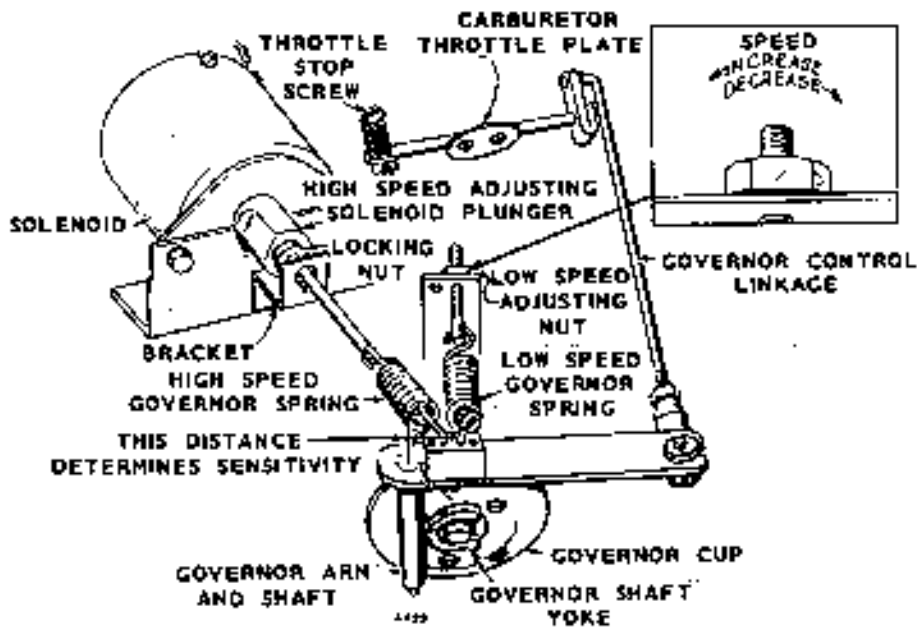

FIGURE 11-24. TWO SPEED GOVERNOR

Two Speed Governor (Electric Solenoid Type): Low speed is controlled by the low speed governor spring. High speed is controlled by both governor springs (low speed and high speed spring).

To adjust the two speed governor, follow the steps as outlined below and refer to Figure 11-24.

1. Run the engine and make necessary carburetor adjustment.
2. Adjust low speed spring tension for the desired low speed (recommended minimum idling speed of 1500 rpm for engines operating under load at idle speed). Decreasing spring tension decreases engine speed. Increasing spring tension increases engine speed.
3. Adjust high speed spring tension by turning the plunger on the adjusting stud (with locking nut loosened) so when the plunger is pulled all the way into the solenoid it gives the desired high speed. Approximately 3000 rpm is the recommended maximum full load speed for continuous operation.

CAUTION Extreme tension on the high speed governor spring will cause damage to the solenoid coil. Tension must be loose enough so that the plunger will pull all the way into the solenoid when operating at high speed. Improper tension does not allow the contact points to open within the solenoid. This condition causes the solenoid coil to overheat.

4. Adjust the sensitivity for high speed operation to attain the smoothest no load to full load operation.

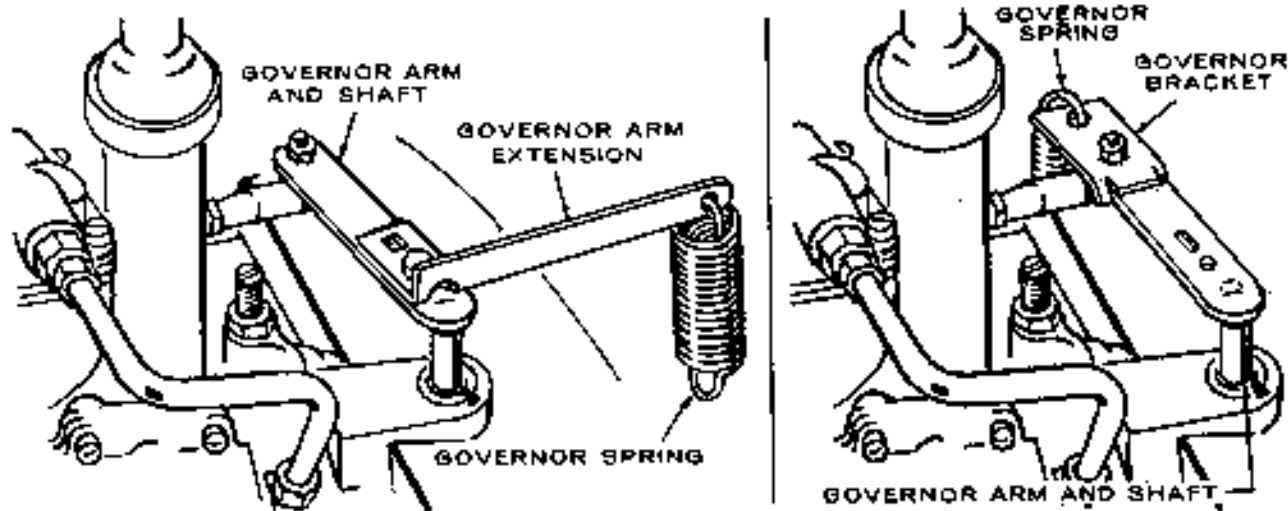

FIGURE 11-25. CONSTANT SPEED GOVERNOR

Rev 10-75

To decrease sensitivity (allow more speed drop from no load to full load operation): Move the high speed governor spring outward into a different hole in the bracket so that the point of pull by the spring is moved slightly away from the governor shaft.

To increase sensitivity (closer regulation by the governor that permits less speed drop from no load to full load operation): Move the high speed governor spring inward to a different hole of the bracket so that the point of pull by the spring is moved slightly closed to the governor shaft.

The low speed governor spring normally requires no sensitivity adjustment and can be moved to another hole in the bracket to allow proper adjustment of the high speed sensitivity. If sensitivity adjustment is required for low speed, move the low speed spring in the same manner as instructed for the high speed spring.

Constant Speed Governor: The CCK industrial engine comes from the factory equipped with either a front, right or left, or rear pull governor assembly. The customer must stipulate when ordering the governor desired.

On the front, right and left controlled models, connect the customer's throttle cable to the governor spring that is attached to the governor arm. On the rear controlled model, no governor arm is used. The governor spring attaches directly to the governor linkage bracket. See Figure 11-25 for an illustrated view of the constant speed governors.

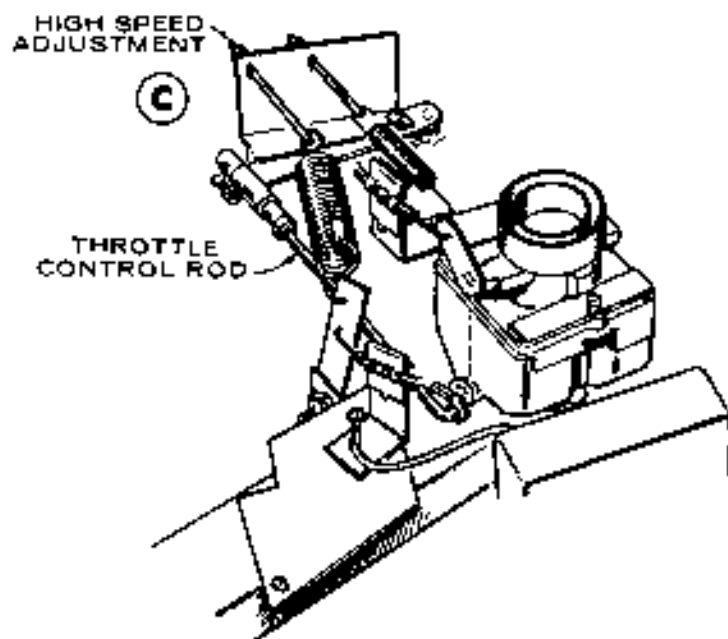

CCKA Tractor Governor Adjustment

Low Speed Adjustment: A tachometer (electric or mechanical) is required to accurately set the governor speed.

1. Use a screwdriver to accurately adjust the throttle stop screw (A) to 1000 rpm when carburetor throttle is held closed (Figure 11-26).
2. Readjust the carburetor idle mixture (B) so engine runs smoothly.
3. Check the adjustment made in Step 1 and readjust the minimum idle speed if necessary.
4. Adjust the nuts so the engine will run at 1200 rpm in the "slow" position. To increase speed, turn the nuts clockwise; to decrease speed, turn counterclockwise.
5. Turn the two nuts securely against each other so they will stay in position.

CCKB TRACTOR GOVERNOR

If the governor requires readjustment, observe the following:

Low Speed Adjustment: A tachometer is required to accurately set the governor speed.

1. Use a screwdriver to adjust the low speed stop screw so the engine runs at 1200 (\pm 100) rpm when the throttle is held closed.
2. Readjust the carburetor idle mixture so the engine runs smoothly.
3. Check adjustment made in Step 1 and readjust minimum idle speed if necessary.

IDLING POSITION

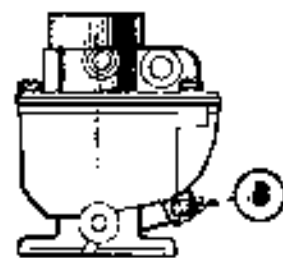
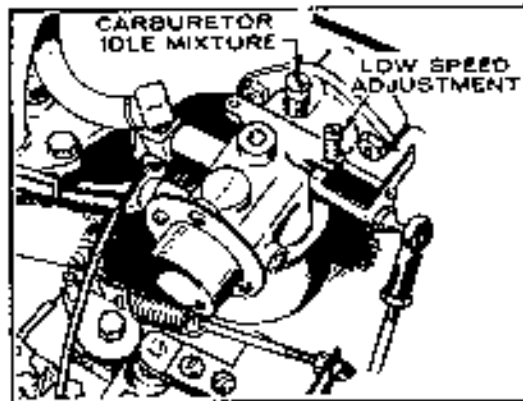
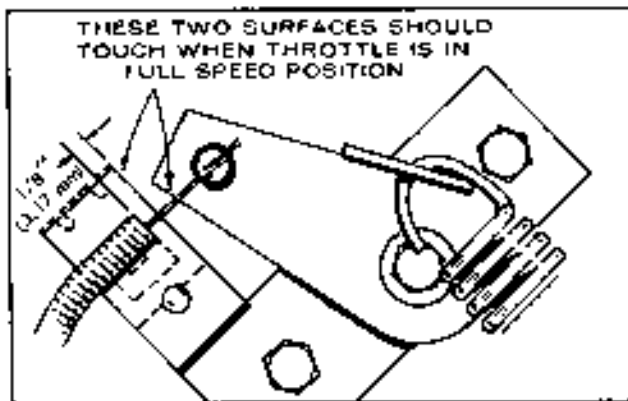

FIGURE 11-26. TRACTOR GOVERNOR ADJUSTMENT



CAUTION
USE 90° PLIERS TO AVOID BENDING PLATE WHEN REINSTALLING CABLE CLIP

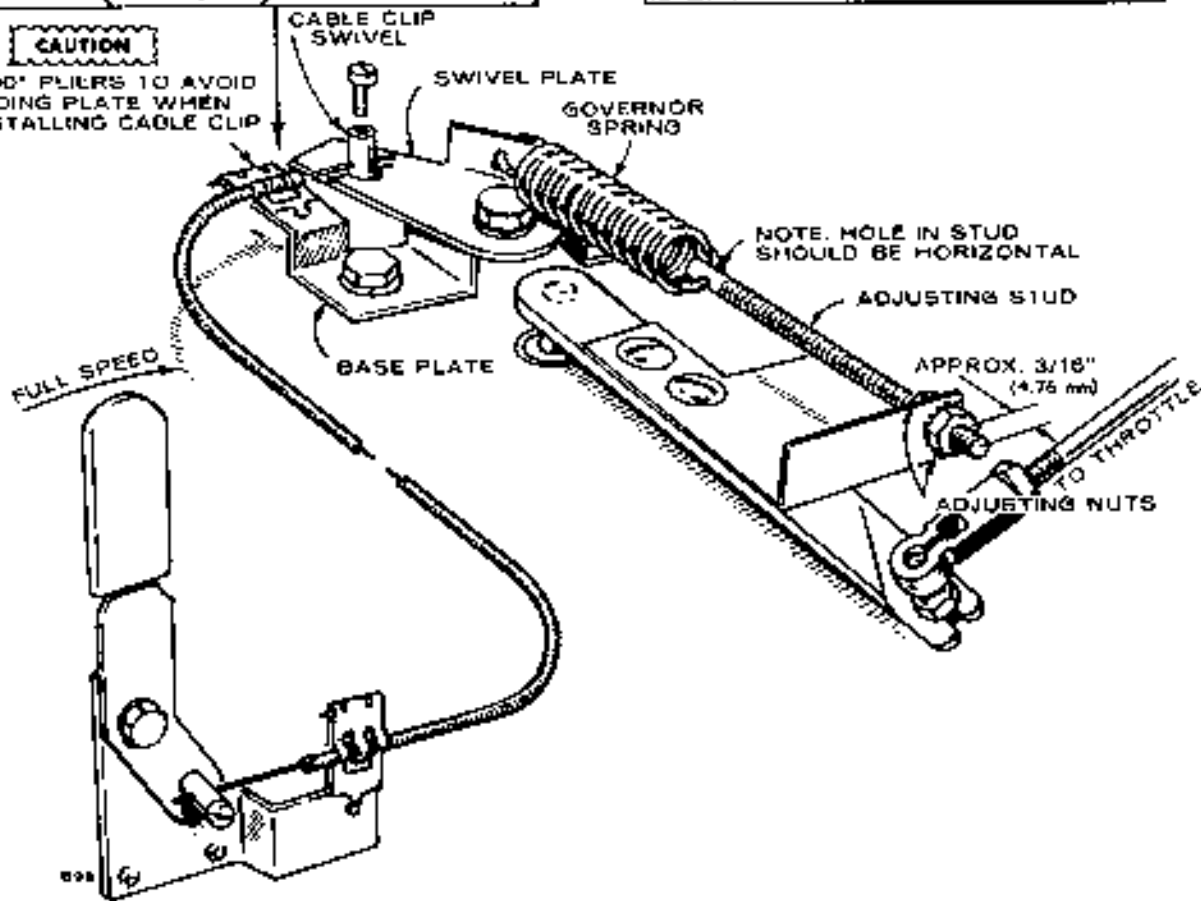

FIGURE 11-27. CCKB TRACTOR GOVERNOR

High Speed Adjustment:

1. Move the engine speed control all the way ahead to the "fast" position.
2. Turn the adjustment nuts (C) clockwise or counterclockwise as required so engine runs between 3800 and 3850 rpm.

CAUTION Engine was not designed to operate at speed greater than 3850 rpm.

3. Tighten the two nuts against each other so they will stay in position.

Cleaning: Inspect the governor linkage, springs, etc. for binding or wear. Clean often in dusty conditions. Blow dust and dirt from linkage with compressed air. Use an approved solvent and apply with a soft brush to remove excessive grease or oil.

High Speed and Cable Adjustment:

1. Move engine speed control on tractor to "fast" position.
2. With speed control in "fast" position, the speed control cable should be holding governor swivel against stop on governor base plate.

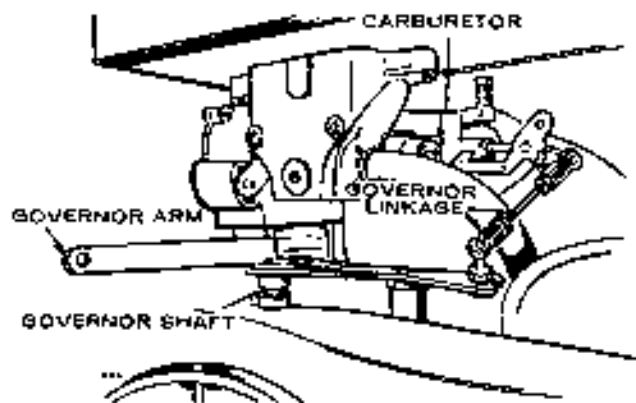

FIGURE 11-28. CCKB CONSTANT SPEED GOVERNOR

3. If speed adjustment is necessary, remove cable housing 1/8 inch (3.16 mm) from base plate mounting edge and using a 90° pliers reinstall cable clip.

CAUTION Bending the base plate will cause misalignment between swivel plate and the edge of base plate.

4. Back off from "fast" position on throttle control arm until inner cable moves forward about 1/16 inch (1.59 mm).
5. Hold the swivel plate against the stop edge and tighten the swivel screw. Recheck to see if control pulls swivel plate against the base plate.
6. With engine running, loosen stud adjusting nuts and turn toward spring (left) to increase or away from spring (right) to decrease the high speed. Tighten nuts and check speed.
7. Top speed at no load should be 3850 (+100) rpm.

CCKB CONSTANT SPEED GOVERNOR

The standard governor for the CCKB is a constant speed governor. It is equipped with a governor arm extension with either a right, front, left or rear pull from the governor arm. The governor spring is usually connected to a remote cable or rod to a console. No adjustments are made with this type of governor. Sensitivity is constant.

Check the governor arm, linkage, throttle shaft and lever for binding or excessive wear at connecting points. Binding at any point causes the governor to act slowly and regulation to be poor. Excessive looseness causes hunting and regulation is erratic. Work the arm back and forth several times by hand while the engine is idle. Replace parts as needed.

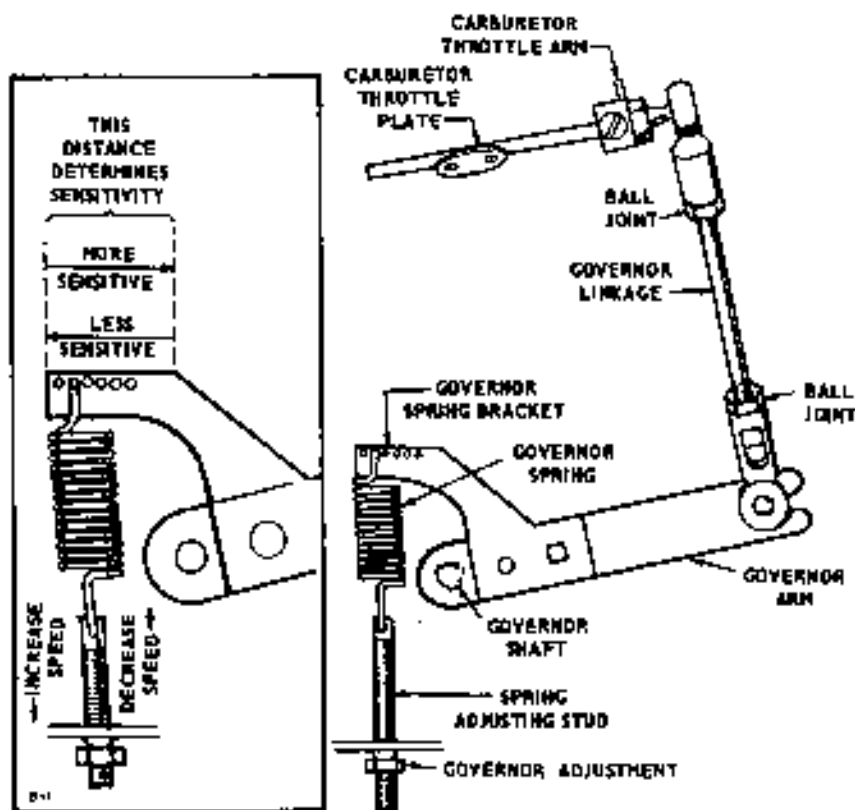

FIGURE 11-29. NH GOVERNOR ADJUSTMENTS

NH, NHA, NHB, NHC Industrial Engine Governor Adjustment

Where engine speed is governor controlled, the governor is set at the factory to allow a nominal engine speed of 3600 rpm at no load operation (unless another speed is specified when the engine is ordered). Proper governor adjustment is one of the most important factors in maintaining the power and speed desired from the engine.

Linkage: The engine starts at wide open throttle. Adjust the length of the linkage connecting the governor arm to the throttle arm by rotating the ball joint housing. Adjust the length so that with the engine stopped and tension on the governor spring, the stop on the carburetor throttle lever is 1/32 inch (0.79 mm) from the carburetor stop boss. This setting allows immediate control by the governor after starting and synchronizes travel of the governor arm and the throttle shaft.

Speed Adjustment: Tension applied to the governor spring determines engine speed. Increasing spring tension increases engine speed. Decreasing spring tension decreases engine speed. The no load speed of the engine should be slightly higher than the speed requirements of the connected load. For example: If the connected load is to turn at 3510 rpm, set the no load speed of the engine at about 3600 rpm. Check speed with a tachometer.

If a speed adjustment is needed, turn the speed adjusting nut in to increase the speed or out to decrease the speed (Figure 11-29).

Sensitivity Adjustment: The engine speed drop from no load to full load should be no less than 100 rpm. Check the engine speed with no load connected and again after connecting full load. Do not exceed 4000 rpm at no load.

The sensitivity of the governor depends upon the position of the arm end of the governor spring. A series of holes in the governor arm provides for adjustment. To increase sensitivity, move the spring toward the governor shaft. To decrease sensitivity, move the spring toward the linkage end of the governor arm.

If the setting is too sensitive, a hunting condition (alternate increase and decrease in engine speed) will result. If the setting is not sensitive enough, the speed variation between no load and full load conditions will be too great. Therefore, the correct sensitivity will result in the most stable speed regulation without causing a surge condition.

Always recheck the speed adjustment after a sensitivity adjustment. Increasing sensitivity will cause a slight decrease in speed and will require a slight increase in the governor spring tension.

Variable Speed Governor Adjustment: These engines are adapted for use where a wide range of speed settings is desired. Engine speed is controlled at any given point between minimum and maximum by shifting the speed lever on the blower housing until the desired speed is reached.

The design of the variable speed governor gives an automatic decrease in sensitivity when the speed is increased and the result is good stability at all speeds.

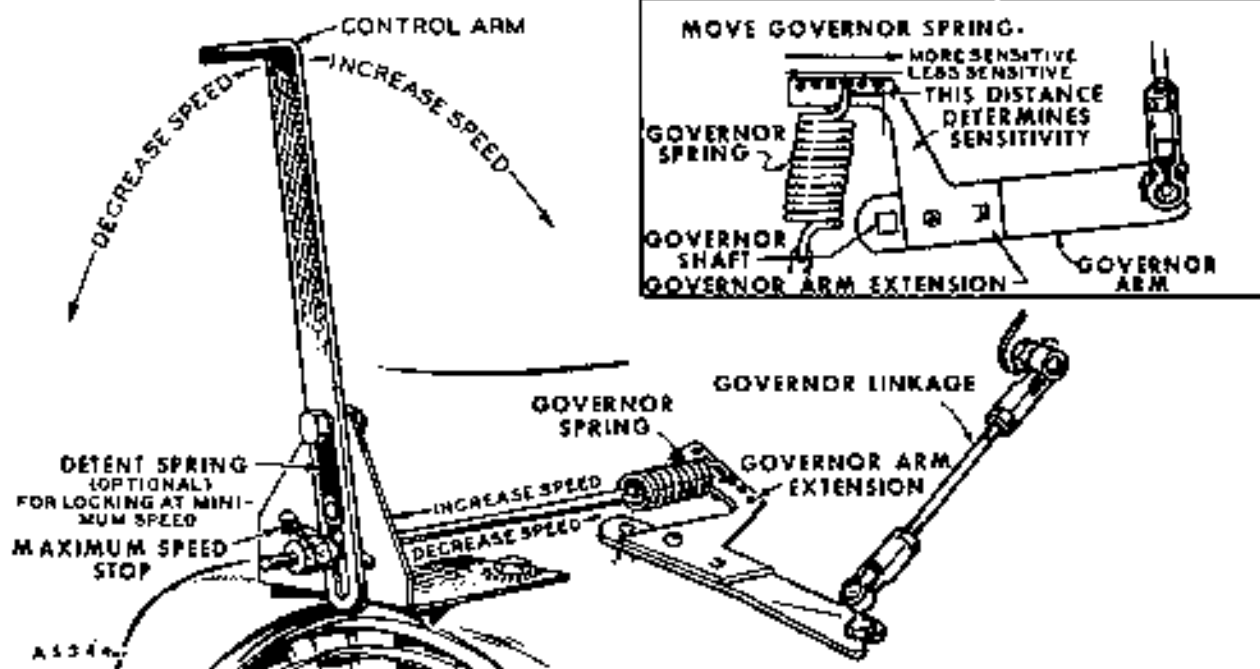

FIGURE 11-30. VARIABLE SPEED GOVERNOR

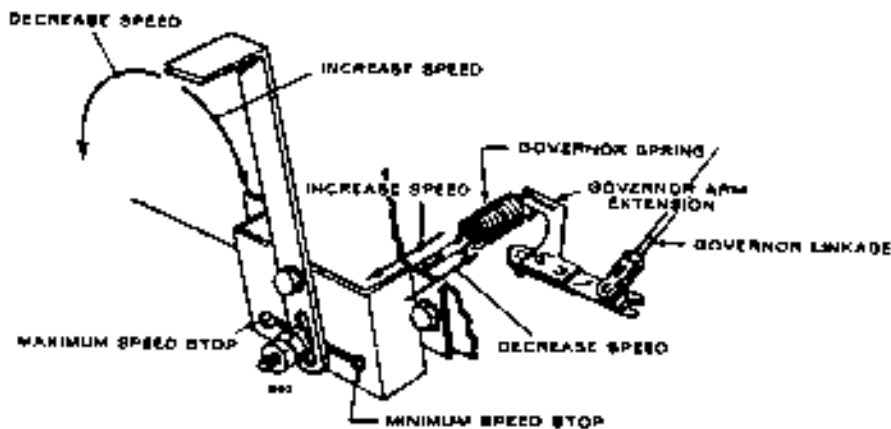

FIGURE 11-31. VARIABLE SPEED GOVERNOR

To adjust the variable speed governor, refer to Figure 11-30 and the following:

1. Run the engine and make necessary carburetor adjustments.
2. Adjust the throttle stop screw on the carburetor to allow a recommended minimum idling speed of 900 rpm. (A lower minimum does not assure smooth operation under load.)
3. Adjust the tension of the governor spring for minimum speed. Adjust the speed spring so that shifting of the speed lever will give a desired range of speeds. First, shift the lever to minimum (slow) position and with no load connected, adjust the spring tension for about 1500 rpm.
4. Adjust the sensitivity while operating at minimum speed to attain the smoothest no load to full load operation as follows:
 - To decrease sensitivity (allow more speed drop from no load to full load operation): Move the governor spring outward into a different groove or hole in the extension arm.
 - To increase sensitivity (closer regulation by the governor which permits less speed drop from no load to full load operation): Move the governor spring inward into a different groove or hole in the extension arm.
5. Apply a full load and shift the lever until the engine speed reaches the desired maximum speed. Set the screw in the bracket slot to stop lever travel at the desired maximum full load speed position. Approximately 3000 rpm is the recommended maximum full load speed for continuous operation. The speed must agree with the load requirements.

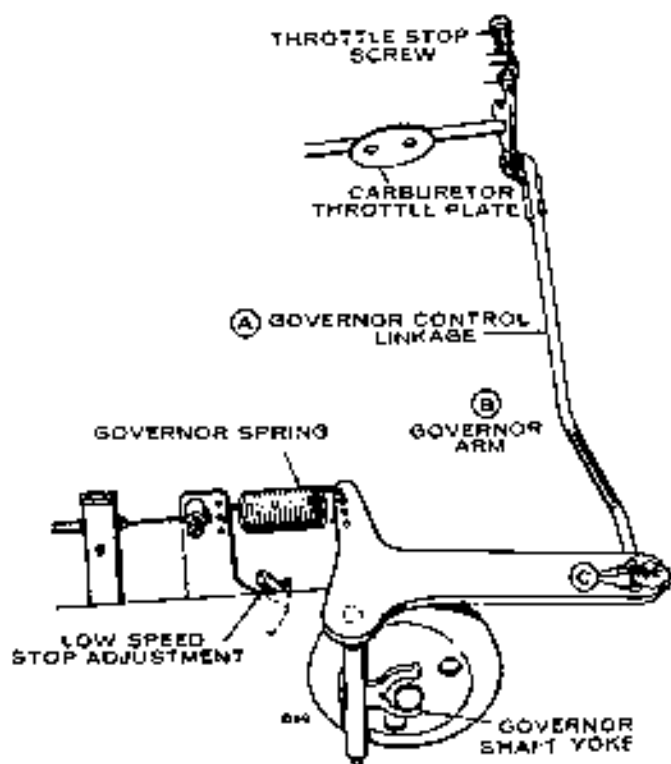

FIGURE 11-32. BF TRACTOR GOVERNOR

BF Tractor Governor

The BF tractor engines are adaptable to a wide range of speed settings. Shifting the throttle lever on the dash panel of the tractor controls engine speed.

Check the governor arm, linkage, throttle shaft and wear at connecting points. A binding condition at any point causes the governor to act slowly and regulation to be poor. Excessive looseness causes a hunting condition and erratic regulation. Work the governor arm back and forth several times by hand while the engine is idling to check for above conditions.

If the governor is hunting or not operating properly, adjust as follows and as shown in Figure 11-32.

1. Disconnect linkage (A) from one of the holes (C).
2. Push linkage (A) and governor arm (B) as far back (toward carburetor) as they will go.
3. Holding linkage and governor arm toward direction of carburetor, insert end of linkage into whichever hole (C) in the governor arm lines up the closest.

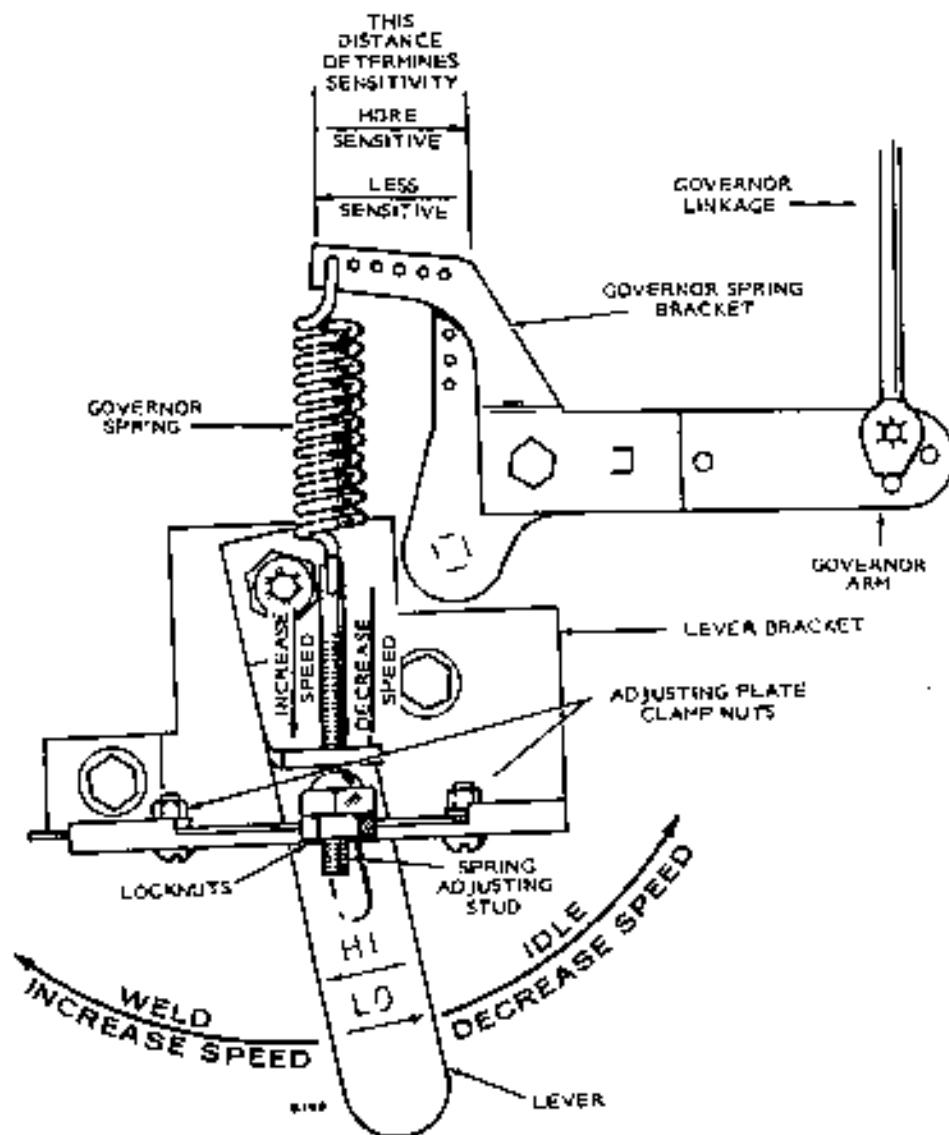

FIGURE 11-33. BF WELDER GOVERNOR ADJUSTMENTS

The governor control spring is factory set in the top hole of the governor control shaft bracket. To increase the sensitivity, move the spring loop into the hole nearest the control. To decrease the sensitivity, move the spring outward. After the sensitivity has been set, adjust the low speed with the adjustment screw on the control wire bracket.

BF Welder Governor Adjustments

Engine speed is controlled at idle (approximately 2200 to 2300 rpm) and maximum (approximately 3600 rpm) by shifting the governor control lever up for high speed and down for idle.

The design of the governor gives an automatic decrease in sensitivity when the speed is increased resulting in good stability at both speeds.

Allow the engine to reach normal operating temperature before making adjustments. If the engine is running with the throttle wide open, either the governor is not properly adjusted or the engine is overloaded.

Linkage: The engine starts at wide open throttle. The length of the linkage connecting the governor arm to the throttle arm is adjusted by rotating the ball joint. Adjust length so that with the engine stopped and tension on the governor spring, the lower stop on the carburetor throttle lever is 1/32 inch (0.79 mm) from the stop pin. This setting allows immediate control by the governor after starting and synchronizes travel of the governor arm and the throttle shaft.

Speed Adjustment: The tension applied to the governor spring determines engine speed: Increasing spring tension increases engine speed; decreasing spring tension decreases engine speed. The no-load speed of the engine should be slightly higher than the speed requirements of the connected load.

If a speed adjustment is needed, turn the speed adjusting in to increase the speed or out to decrease the speed.

The sensitivity of the governor depends on the position of the arm end of the governor spring. A threaded stud on the governor arm provides for adjustment. To increase sensitivity, move the governor spring toward the governor shaft by turning the screw in; to decrease sensitivity, move the governor spring away from the governor shaft by turning the screw out.

BF/NH POWER DRAWER GOVERNOR ADJUSTMENT

Governor adjustments on the 4.0BF and 6.0NH Power Drawers are the same. Before making governor adjustments, run the unit about 15 minutes under light load to reach normal operating temperature. If the governor is completely out of adjustment, make a preliminary adjustment at no load to first reach a safe voltage operating speed.

Engine speed determines the output voltage and current frequency of the generator. By increasing the engine speed, generator voltage and frequency are increased and by decreasing the engine speed, generator voltage and frequency are decreased. An accurate voltmeter or frequency meter (preferably both) should be connected to the generator output in order to correctly adjust the governor. A small speed

drop not noticeable without instruments will result in an objectionable voltage drop. Check engine speed with a tachometer.

Linkage: The engine starts at wide open throttle. Adjust the length of the linkage connecting the governor arm to the throttle shaft and lever by rotating the ball joint. Adjust this length so that with the engine stopped and tension on the governor spring the stop on the carburetor throttle lever just contacts the underside of the carburetor bowl. This setting allows immediate control by the governor after starting. It also synchronizes travel of the governor arm and the throttle shaft.

Speed Adjustment: With the warmed-up unit operating at no load, adjust the tension of the governor spring. Refer to the *Voltage and Speed Charts*. Check the voltage and speed, first with no load connected and again with a full load. Adjust the sensitivity to give the closest regulation (least speed and voltage difference between no load and full load) without causing a hunting condition.

To increase sensitivity (closer regulation), shift the spring toward the governor shaft.

An adjustment for too much sensitivity will cause alternate increase and decrease of engine speed (hunting).

To decrease sensitivity, shift the spring toward the outer end of the governor arm. Too little sensitivity will result in too much difference in speed between no load and full load conditions.

Any change in the sensitivity adjustment usually requires a compensating speed (spring tension) adjustment.

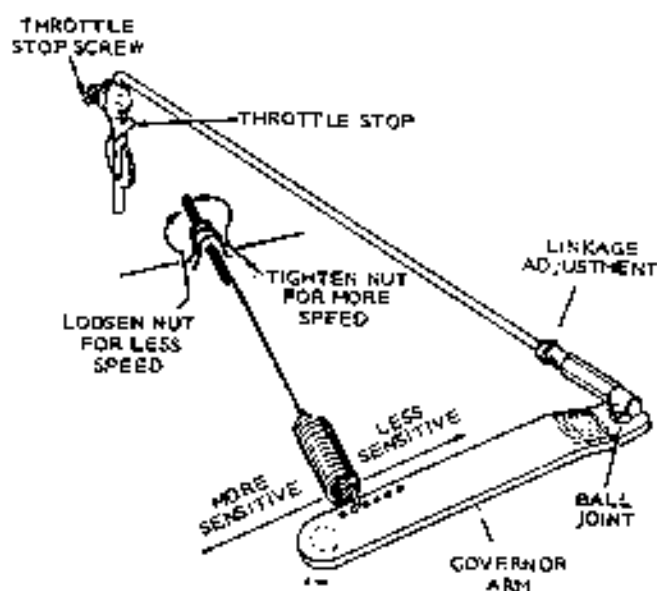

VOLTAGE CHART FOR CHECKING GOVERNOR REGULATOR	120 VOLT 1 PHASE 2 WIRE
MAXIMUM NO-LOAD VOLTAGE	126
MINIMUM FULL-LOAD VOLTAGE	110
SPEED CHART FOR CHECKING GOVERNOR REGULATION	
MAXIMUM NO-LOAD SPEED (RPM)	1890
HERTZ (CURRENT FREQUENCY)	63
MINIMUM FULL-LOAD SPEED (RPM)	1770
HERTZ	59

FIGURE 11-34. POWER DRAWER GOVERNOR ADJUSTMENTS

SECTION 12.

LUBRICATION SYSTEM

SPLASH LUBRICATION	12-1
PRESSURE LUBRICATION	12-1
MAINTENANCE	12-1
OIL PUMP	12-1
Inspection and Repair	12-1
Installation	12-3
BREATHER SYSTEM	12-3
OIL PRESSURE RELIEF VALVES	12-3
OIL LINES	12-5
VALVE COMPARTMENT OIL DRAIN	12-5
OIL FILTERS	12-5
OIL PRESSURE GAUGE	12-5
Oil Pressure Switch	12-6
LOW OIL PRESSURE CUT-OFF SWITCH	12-6
Pressure Switch	12-6
Emergency Relay	12-6
Centrifugal Switch	12-6
Disassembly	12-7
Repair	12-7
Assembly	12-7
LOW OIL PRESSURE CUT-OFF SWITCH FIELD INSTALLATION—CCK ENGINE	12-8
LOW OIL PRESSURE CUT-OFF SWITCH FIELD INSTALLATION—J SERIES	12-8
OIL COOLER (DJC Only)	12-8
TABLE 12-1. LUBRICATION SYSTEMS AND OIL FILTER NUMBERS	12-9

Onan engines use both splash and pressure lubrication. Table 12-1 lists the various Onan engines and their methods of lubrication. Engines equipped with full flow oil filters and the filter part number are also listed in Table 12-1.

SPLASH LUBRICATION

Splash lubricated engines use an oil dipper attached to the connecting rod. The dipper picks up oil and splashes it throughout the crankcase and valve area. When overhauling the engine, inspect the dipper for bends. Replace if damaged.

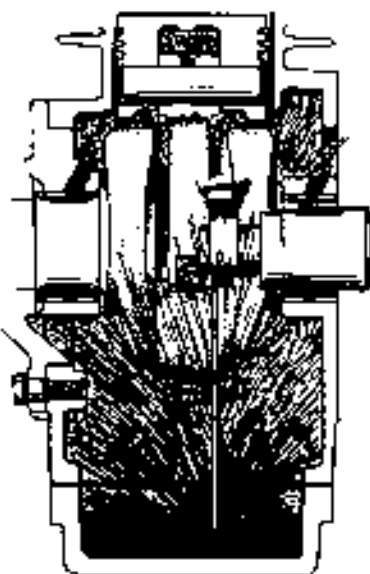

FIGURE 12-1. SPLASH LUBRICATION SYSTEM

PRESSURE LUBRICATION

The pressure lubrication systems used on most Onan engines are shown in Figure 12-2. The oil pump picks up the oil from the sump and pumps it through the oil filter—when a filter is used.

Not all engines are equipped with an oil filter. Table 12-1 illustrates which engines use oil filters.

After leaving the filter, oil moves through a drilled passage into the main oil gallery that extends the length of the cylinder block. The oil then flows under pressure to the main bearing journals and through drilled passages in the crankshaft, to the connecting rod bearings. Oil also flows under pressure from the oil gallery to the camshaft bearing bosses. On J series engines, oil is pumped through oil lines, to the top of the rocker box covers where fine holes in the oil lines allow it to spray over the rocker arms and valve assemblies. Oil then drains down through the pushrod holes lubricating the pushrods, tappets and cam lobes. On J series engines, oil spray also lubricates the camshaft and piston pins from a spurt hole in the connecting rod.

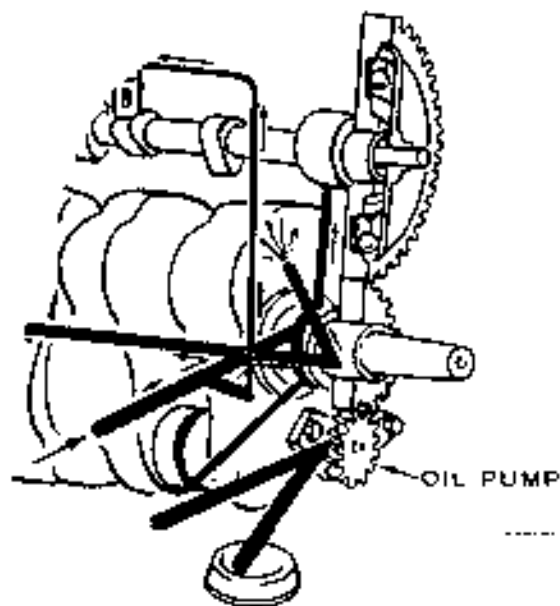

FIGURE 12-3. OIL PUMP LOCATION

All Onan engines use a crankcase breather system to aid in controlling exhaust emissions.

MAINTENANCE

Periodic oil system maintenance includes changing crankcase oil, replacing oil filter, cleaning the crankcase breather and cleaning the rocker box oil lines. Table 12-1 lists the oil filter part numbers for all Onan engines. See appropriate Onan Operator's Manual for recommended oils.

WARNING

Do not remove the oil dipstick while the engine is running. Oil can blow out of the oil fill tube causing injury.

OIL PUMP

A gear type oil pump is used on Onan engines. The crankshaft gear drives the pump that mounts on the front of the engine block (Figure 12-3).

Removal:

1. Drain crankcase oil.
2. Remove the gear cover and oil base (see Section 14 of this manual).
3. Unscrew the intake pump from the oil pump.
4. Loosen the two cap screws holding the pump and remove it.

Inspection and Repair

Except for gaskets, component parts of the oil pump are not available. If the pump is excessively worn, replace it. Disassemble the pump by removing the two

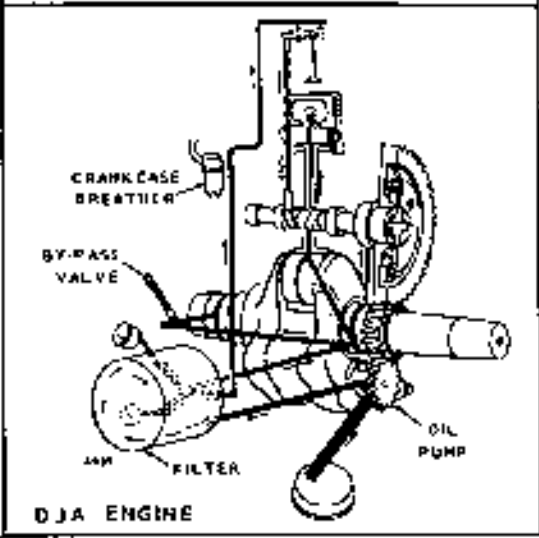
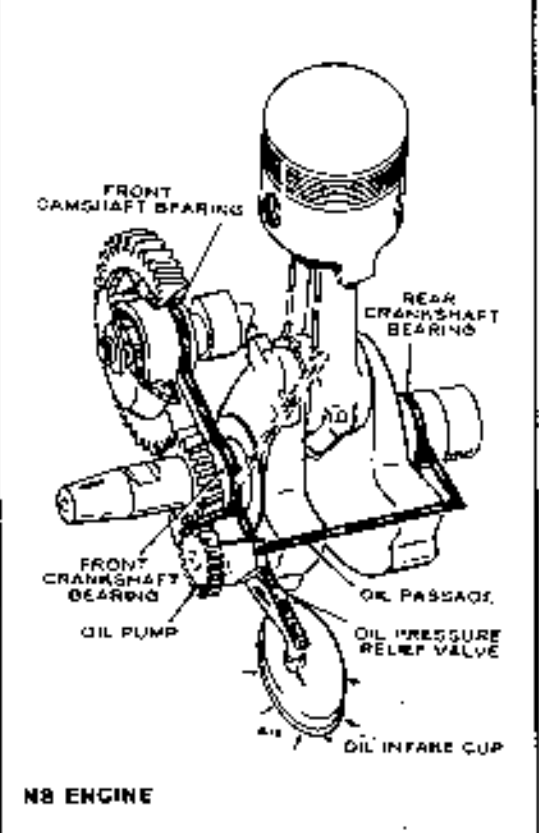
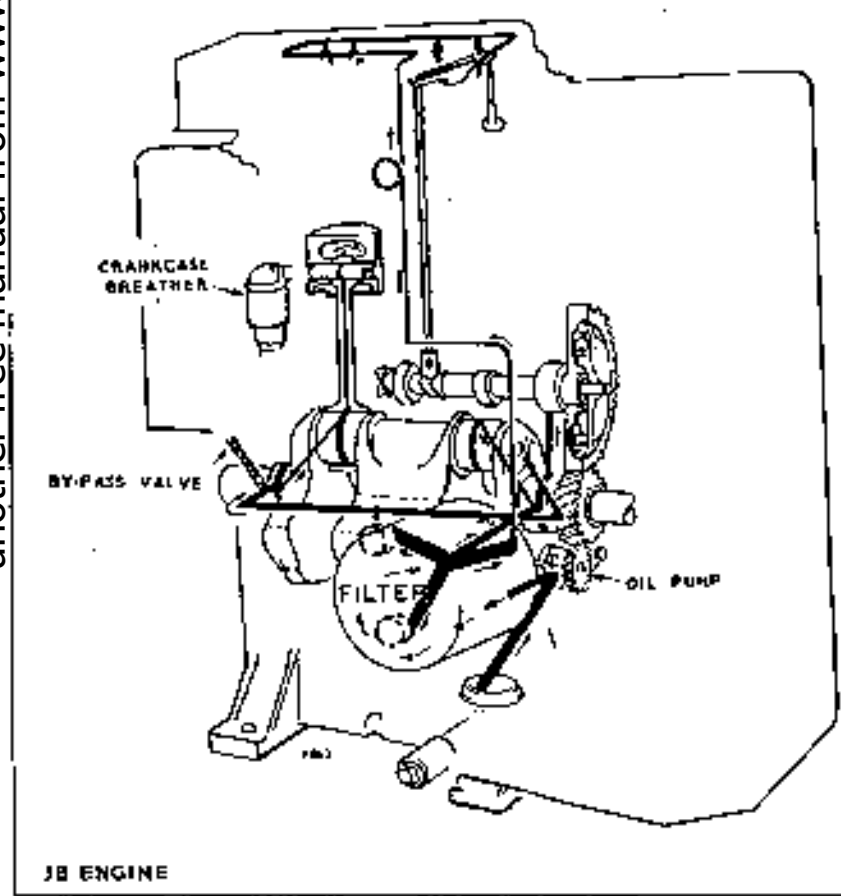
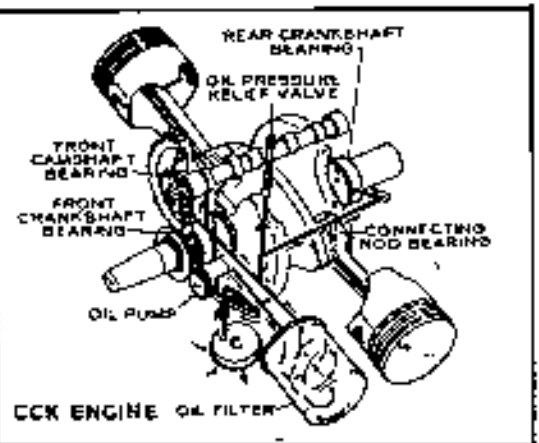
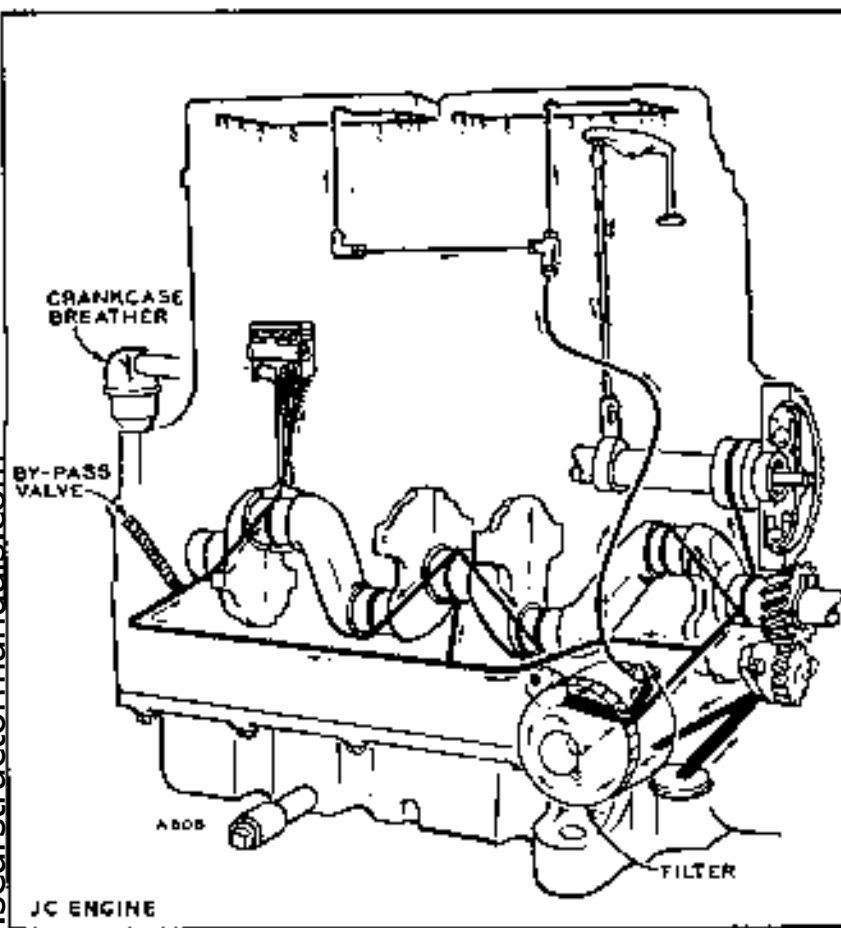

FIGURE 12-2. PRESSURE LUBRICATION SYSTEM

Rev 10-75

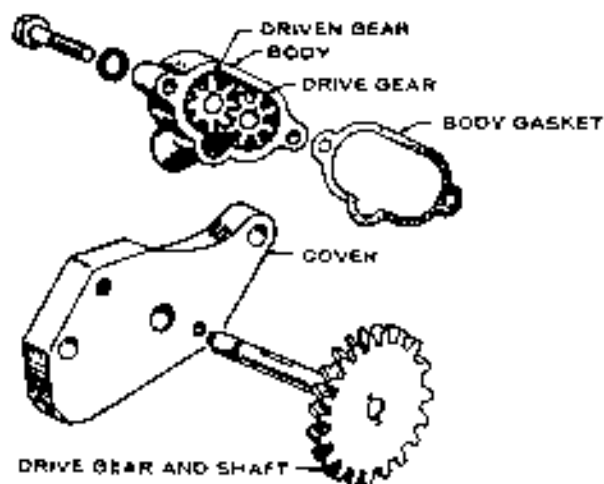

FIGURE 12-4. OIL PUMP ASSEMBLY AND GASKET

cap screws holding the pump cover to the body. Inspect for excessive wear in the gears and shafts. To improve pump performance, adjust the gear end clearance by changing the gasket thickness between the pump body and cover (Figure 12-4). Use the thinnest gasket that permits free movement of the pump shaft. Oil all parts when assembling the pump.

To measure the gear clearance between the pump gears and cover, place gears in the housing. As shown in Figure 12-5, place a straight edge on the pump body across the gears, then check the clearance with a feeler gauge. If excessive clearance is evident, replace the oil pump. If the clearance between the oil pump gear teeth is excessive, replace the oil pump.

Installation

Before installing, fill the pump intake and outlet with oil to ensure that it is primed. Mount the pump on the

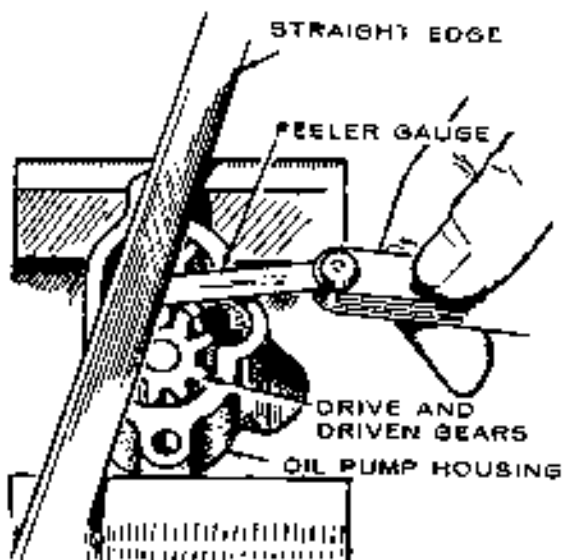

FIGURE 12-5. CHECKING OIL PUMP FOR WEAR

engine and adjust for .005 inch (0.127 mm) clearance between the pump gear and crankshaft gear. Mount the intake cup on the pump so it is parallel to the bottom of the crankcase. Install the gear cover and oil base. Fill crankcase with oil. Start engine and check for proper oil pressure.

BREATHER SYSTEM

All Onan engines have a crankcase breather system. Clean crankcase breathers after every 200 hours of engine operation with a suitable solvent. Figure 12-6 illustrates the types of breathers used.

OIL PRESSURE RELIEF VALVES

The oil pressure relief valve is in the engine oil line and controls oil pressure by returning excess oil back to the crankcase. The valve normally opens at 25 psi (173 kPa). A plunger sticking closed causes high oil pressure; a plunger sticking opened causes low oil pressure. To inspect the valve, see Figure 12-7.

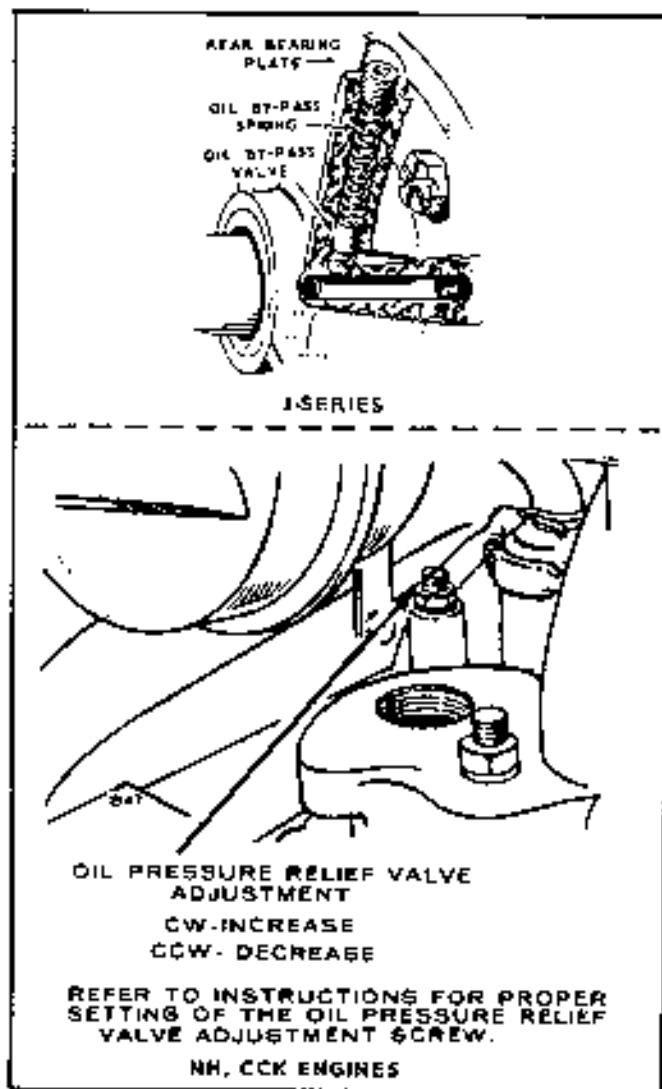

FIGURE 12-7. OIL PRESSURE RELIEF VALVES

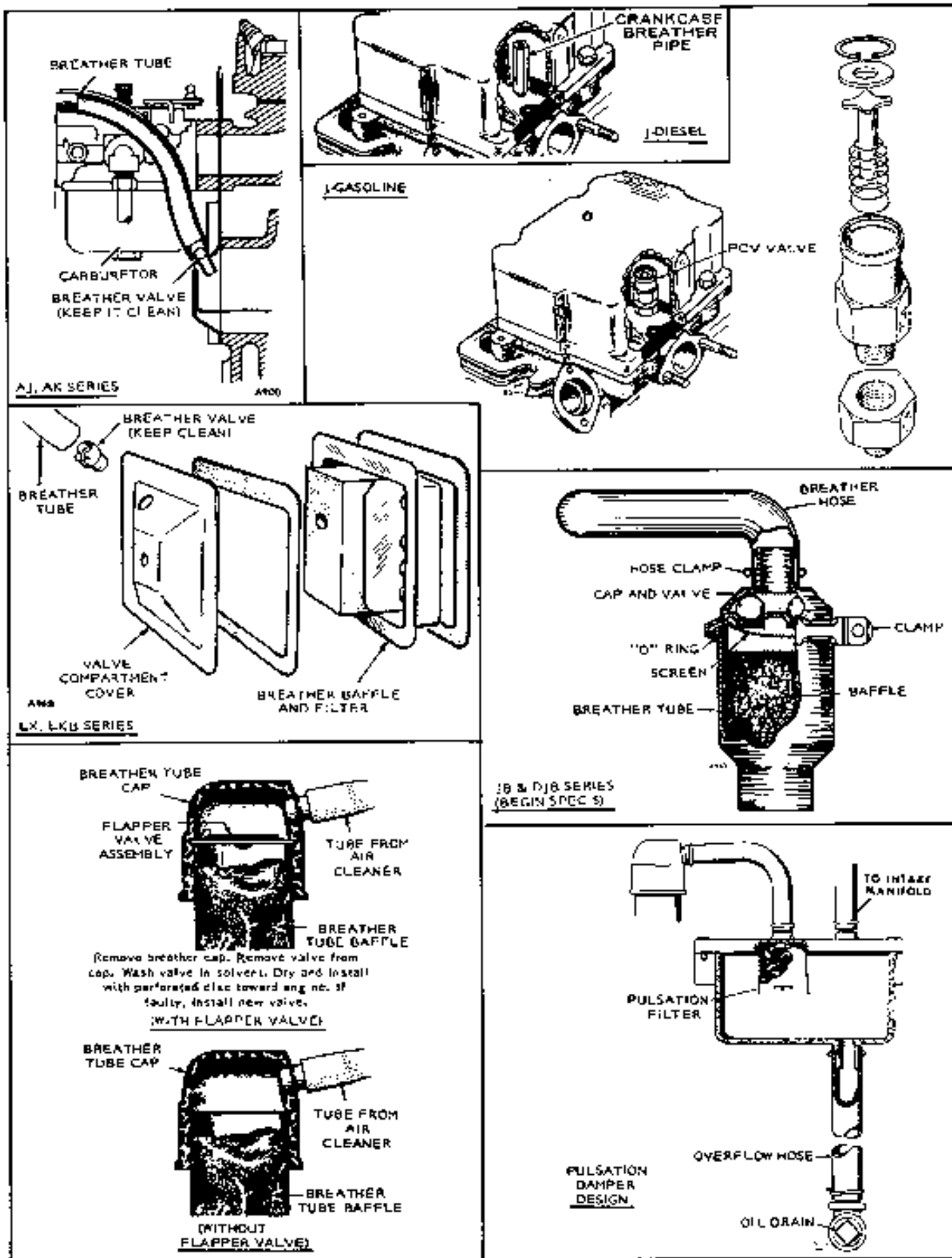

FIGURE 12-6. CRANKCASE BREATHING SYSTEMS

Rev 10-75

On J series generator sets, remove the generator to work on the relief valve.

1. Unscrew the recessed plug.
2. Lift out the spring and plunger assembly.
3. Determine the valve operation by comparing spring and plunger specifications following:

Plunger Diameter3365" to .3380" (8.5471 - 8.5852 mm)
Spring Free Length	2-5/16" + 1/16" (58.7375 - 1.5875 mm)
Spring Compression @ 1-3/16" (30.163 mm)	2.225 lb. (15.3525 kPa) 2.335 lb. (16.1115 kPa)

On CCK and NH engines, the oil pressure should be between 20 (138 kPa) and 35 pounds (242 kPa). To increase oil pressure, loosen the locknut and turn the stud inward. To decrease oil pressure, loosen the locknut and turn the stud outward. Tighten the locknut securely after making the adjustment.

OIL LINES

At engine overhaul time, carefully clean all oil lines with a suitable cleaning solvent. Blow them out with compressed air.

On J series engines flush the rocker box lines with cleaning solvent and use a fine wire to clean the line holes in the line (Figure 12-8). Reach the oil gauge passage by removing the oil filter mounting plate. All external oil lines, the rocker box oil line and the internal oil line to the rear bearing are replaceable if damaged.

VALVE COMPARTMENT OIL DRAIN

A drain hole from the valve compartment enters the crankcase. Periodically inspect this hole and keep unobstructed to provide proper drainage.

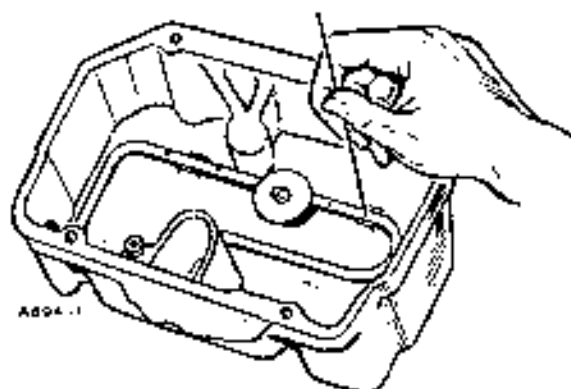

FLUSH ROCKER BOX OIL LINE WITH FUEL AND CLEAN HOLES WITH FINE WIRE.

FIGURE 12-8. CLEANING J SERIES OIL LINE

OIL FILTERS

Some Onan engines use a full-flow oil filter. Oil is filtered enroute to the bearings. A by-pass permits unfiltered oil to reach the bearings if the filter becomes clogged. Replace the oil filter after every 200 hours of engine operation. To change the oil filter:

1. Drain crankcase oil.
2. Place a drip pan below the filter.
3. Unscrew the oil filter counterclockwise, using both hands or an Onan filter wrench.
4. Clean the filter mounting area and lubricate the filter gasket with engine oil.
5. Turn the new filter on hand tight and then one additional half turn.
6. Refill the engine crankcase with the recommended oil, run the engine and check for oil leaks at the filter gasket.

CAUTION Do not over-tighten the oil filter. Be sure ring is installed around oil filter. This ring acts like an air seal and prevents loss of cooling air.

Change the oil filter more often if the oil becomes excessively dirty. This may occur during extremely dusty conditions or freezing temperatures. When filling the crankcase with new oil, allow 1/2 quart (.473 lit) extra to compensate for the new filter.

CAUTION Do not overfill crankcase. Do not use service DS oil. Do not mix brands or grades of motor oil.

OIL PRESSURE GAUGE

Some CCK, NH and J series units have oil pressure gauges (Figure 12-9). If faulty, replace it. Remove with

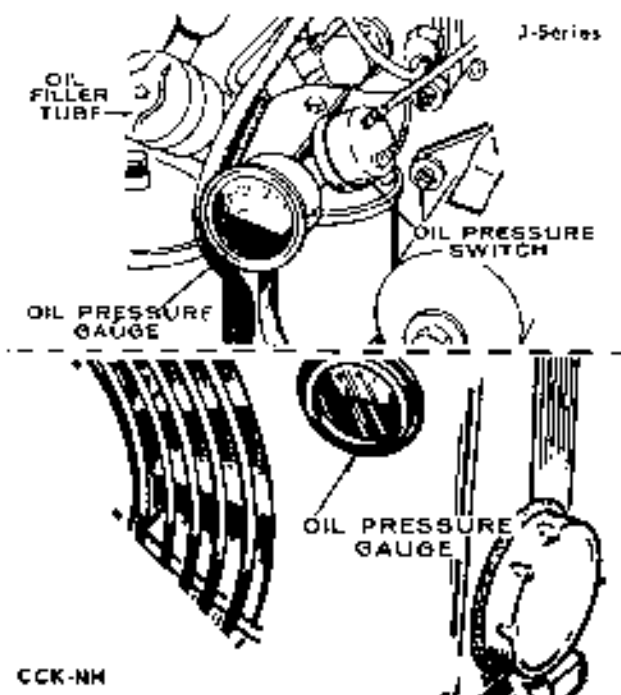

FIGURE 12-9. OIL PRESSURE GAUGE

a wrench and screw in a new gauge. Before replacing, check for a clogged oil passage.

Oil Pressure Switch

The nonadjustable oil pressure switch controls the decompression solenoid in the starting system, allowing it to energize only when the switch closes. This allows the engine to build up speed, during starting, before compression occurs. The switch closes at about 5 psi (35 kPa) under increasing oil pressure.

CAUTION This is not a low oil pressure protection switch. It will not protect the engine against slowly decreasing oil pressure.

If the decompression switch does not energize, check switch operation. Short the switch to ground when the engine has built up speed during starting. The governor solenoid should energize immediately and the engine should start.

CAUTION When the engine starts, check immediately for oil pressure. Shut the engine down if oil pressure does not build up within a few seconds. In this case, the lack of oil pressure is causing faulty operation, not the switch.

LOW OIL PRESSURE CUT-OFF SWITCH (Optional Equipment)

An optional low oil pressure cut-off switch is available on all J series engines and other two cylinder engines.

The low oil pressure switch is standard equipment on all Marine electric sets.

Either of two systems is used, depending on the application and whether the engine has factory-mounted controls or controls mounted by fabricator.

For engines with factory-mounted controls, the low oil pressure system includes a low oil pressure switch and a special start switch to jumper the cut-off switch during starting.

For engines with fabricator-mounted controls, the low oil pressure system includes a low oil pressure switch, emergency time delay relay, resistor and centrifugal switch.

Low Oil Pressure Switch: The switch (Figure 12-10) is located on the oil filter adapter plate below the oil filter on J series engines or off the oil pressure gauge line on other engines.

The system for engines with factory-mounted controls uses a normally open low oil pressure switch. A special start switch jampers the cut-off switch during starting to allow the engine to build up oil pressure and close the switch. The switch closes at 13 (90 kPa) to 15 psi (104 kPa) under increasing pressure. If oil pressure falls below 13 psi (90 kPa), the switch closes, energizing the emergency relay.

Emergency Relay (Time Delay): This relay is supplied loose and mounted by customer. The relay, used in

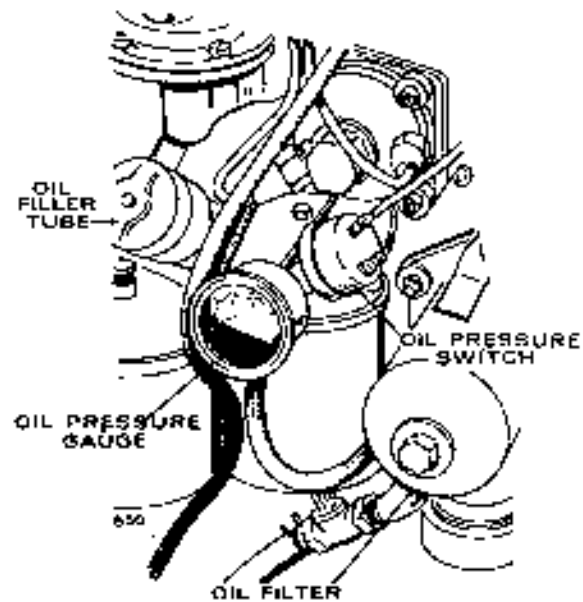

FIGURE 12-10. LOW OIL PRESSURE SWITCH

conjunction with a 1-ohm, 10-watt resistor, provides a 15 to 30-second time delay when starting, so the engine can build up sufficient oil pressure to open the low oil pressure cut-off switch. When oil pressure drops below 13 psi (90 kPa), the relay stops the engine and prevents it from restarting until the Reset button is pushed.

Centrifugal Switch (J Series): This switch (Figure 12-11) is mounted on the gear cover backplate and operates directly off the camshaft gear. Normally open, the switch closes when engine speed builds up to about 900 rpm. This allows the engine to build up sufficient oil pressure and the unit can be started.

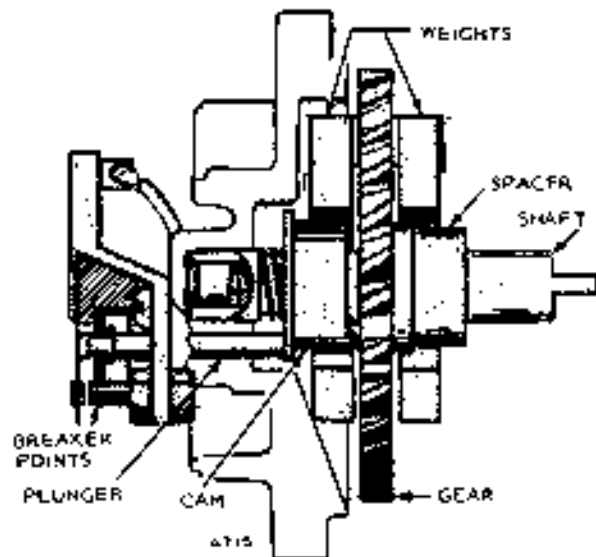

FIGURE 12-11. CENTRIFUGAL SWITCH ASSEMBLY

Rev 10-75

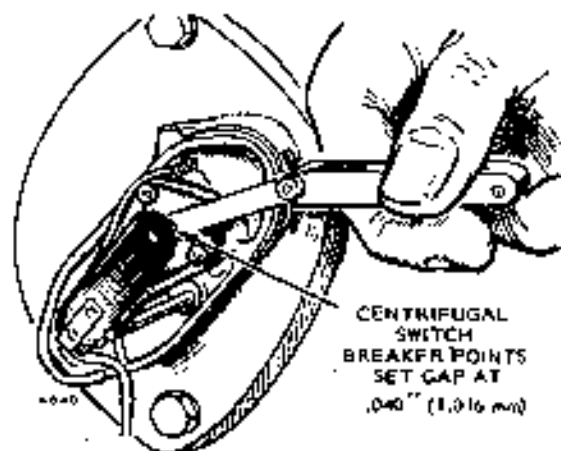

FIGURE 12-12. BREAKER POINTS

For correct operation, maintain the switch gap at .040 inch (1.016 mm). See Figure 12-12.

Check the contacts for dirt or pitting when adjusting the gap. Clean the contacts with paper or replace them if badly pitted.

Disassembly:

1. Disconnect the battery to prevent accidental shorts.
2. Remove the switch cover, revealing the point set.

3. Remove the point set assembly by removing the screws holding it to the plate. Pull out the plunger and plunger diaphragm.
4. Remove the centrifugal switch plate, revealing the cam and weight assembly.
5. Pull out the cam and weight assembly.

CAUTION Be careful not to lose the spacer mounted on the gear shaft behind the gear.

Repair: Thoroughly clean the gear and cam assembly, the bearing surfaces in the gear case and breaker plate, and the oil trickle holes to these bearings. Check the oil spray hole in the gear case to be sure it is open.

Check for wear in the spacer, fiber plunger and the spring loaded shaft plunger. The spacer must be at least .35 inch (8.89 mm) long. If not, replace it immediately. Push the weights outward; they should move freely. If they do not or if any part of the assembly is sticking or worn, replace the cam and weight assembly. If the cam is loose on the gear shaft, replace the assembly.

If the breaker gap cannot be maintained at .040 inch (1.016 mm), check the fiber plunger and spacer for wear.

Assembly:

1. Install the spacer on the shaft and install the shaft

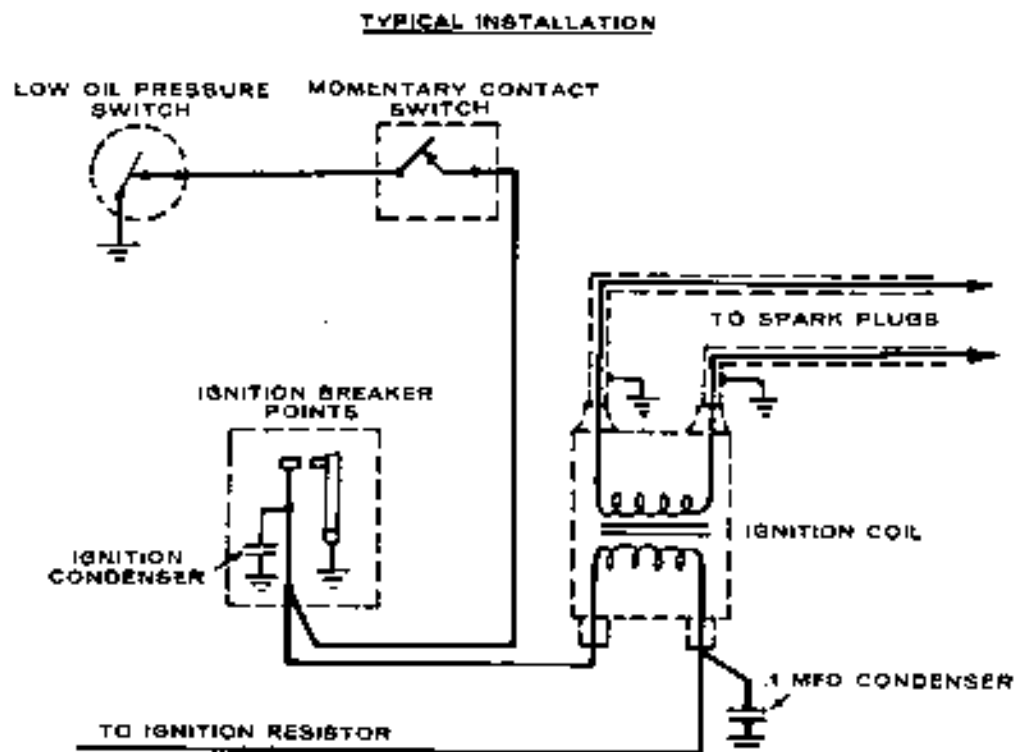

FIGURE 12-13. TYPICAL CCK INSTALLATION

assembly into the gear case. Match it with the cam gear.

2. Install the spring and plunger into the end of the shaft.
3. Install the breaker plate.
4. Install the plunger and diaphragm.
5. Install the breaker points on the breaker plate and set the gap at .040 inch (1.016 mm).
6. Install the switch cover and reconnect the battery.

LOW OIL PRESSURE CUT-OFF SWITCH FIELD INSTALLATION—CCK ENGINE

1. Remove the blower housing, oil pressure gauge line and elbow from the cylinder block. Discard the elbow.

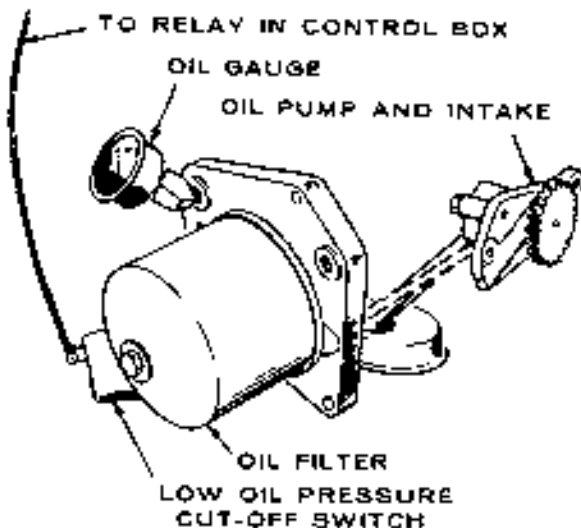
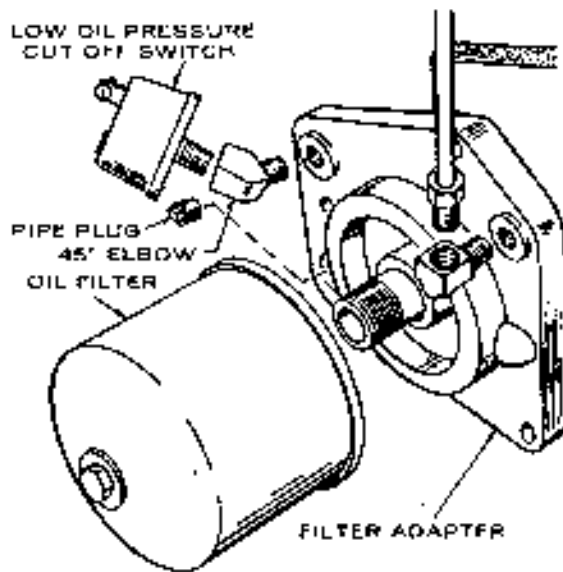

FIGURE 12-14. TYPICAL J SERIES INSTALLATION

2. Install a brass tee into the cylinder block.
3. Connect oil line to one end of the tee.
4. Install the low oil pressure switch into the other end of the tee.

Most units have an open space in the lower right corner of the blower housing. This hole can be enlarged to 1/2 inch (13 mm) diameter or a new hole drilled (allow enough space that the switch to be installed in this hole does not come in contact with the oil gauge).

5. Install the momentary contact switch in this hole.
6. Measure correct wire lengths needed; make electrical leads and wire as shown in Figure 12-13.

This installation procedure applies to units using oil pressure gauges with or without sending units.

LOW OIL PRESSURE CUT-OFF SWITCH FIELD INSTALLATION—J SERIES

1. Install the low oil pressure switch and elbow in the oil filter adapter (Figure 12-14).
2. Remove the knock out plugs from the control box and install the emergency relay.
3. Make wiring connections as indicated in the unit wiring diagram.

Appropriate wiring diagrams can be acquired through your Onan distributor.

OIL COOLER (DJC Only)

The oil cooler (Figure 12-15) mounts in the upper right hand corner of the blower housing facing the

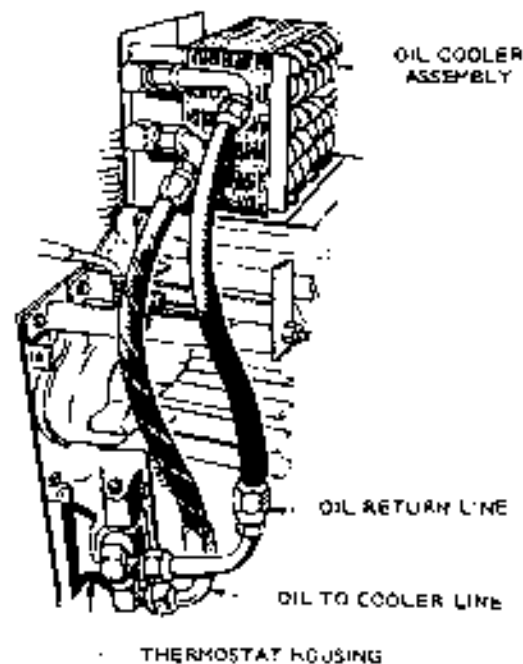

FIGURE 12-15. OIL COOLING SYSTEM—DJC

Rev 10-75

TABLE 12-1.
LUBRICATION SYSTEMS AND OIL FILTERS

	AK	AJ	MAJ	LK	LKB	CKK	CKKA	CKKB	MCKK	PH	NG	JB	MJB
SPLASH LUBRICATION		x	x	x	x						x		
PRES. LUBRICATION	x	x	x			x	x	x	x	x		x	x
OIL FILTER						x	x	x		x		x	x
FILTER NUMBER						*	*	*		*		*	*

- * 122-0323
- * 122-0185

	JC	RJC	RJC	DJA	MDJA	DJB	MDJB	MDJE	DJC	MDJC	MDJF	RDJC	RDJF
SPLASH LUBRICATION													
PRES. LUBRICATION	x	x	x	x	x	x	x	x	x	x	x	x	x
OIL FILTER	x	x	x	x	x	x	x	x	x	x	x	x	x
FILTER NUMBER	*	*	*	*	*	*	*	*	*	*	*	*	*

- * 122-0323
- * 122-0185

engine. Oil flow is controlled by a thermostat in the oil filter adapter casting. When the oil is cold, it goes through a passage directly to the full flow filter. As the oil heats up, the thermostat starts to open at 140° to 145° F (60° to 62.8° C) and is fully open at 165° F (73.9° C). The opening of the thermostat shuts off the passage to the filter. Oil is then diverted through the oil cooler before entering the filter.

Clean out all other oil lines and drillings with compressed air whenever the engine is disassembled or overhauled. Reach the oil gauge passage by removing the oil filter mounting plate.

Periodically, inspect the oil hose and connections. Keep the oil cooler fins clean.

SECTION 13.

EXHAUST SYSTEM

FIXED POSITION AND MOBILE EXHAUST SYSTEM	13-1
Testing Exhaust Back Pressure	13-1
Fixed Location Exhaust System	13-1
Mobile Installation	13-1
MARINE UNIT EXHAUST SYSTEMS	13-3
MATERIAL	13-3
EXHAUST COOLING WATER INJECTION	13-3
EXHAUST LINE INSTALLATION	13-6
MUFFLERS	13-6
Aqualift Marine Muffler Installation	13-7
Before Installing Aqualift	13-7
Aqualift Installation	13-8

FIXED POSITION AND MOBILE EXHAUST SYSTEMS

Exhaust systems for Onan engines are primarily the responsibility of the customer. The importance of exhaust systems, however, cannot be overemphasized. A poor or clogged exhaust system causes low power, overheating and engine damage. A poor exhaust system also increases back pressure which reduces engine efficiency.

WARNING Leaky exhaust systems emit noxious carbon monoxide fumes that are a potential safety hazard in enclosed areas. Have exhaust system checked by qualified service personnel. Figures 13-2 and 13-3 show typical exhaust systems used on Onan units.

Testing Exhaust Back Pressure

To test exhaust system back pressure, install a manometer adapter (tee) in the exhaust line near the manifold or use a condensation trap near the manifold as a manometer connection.

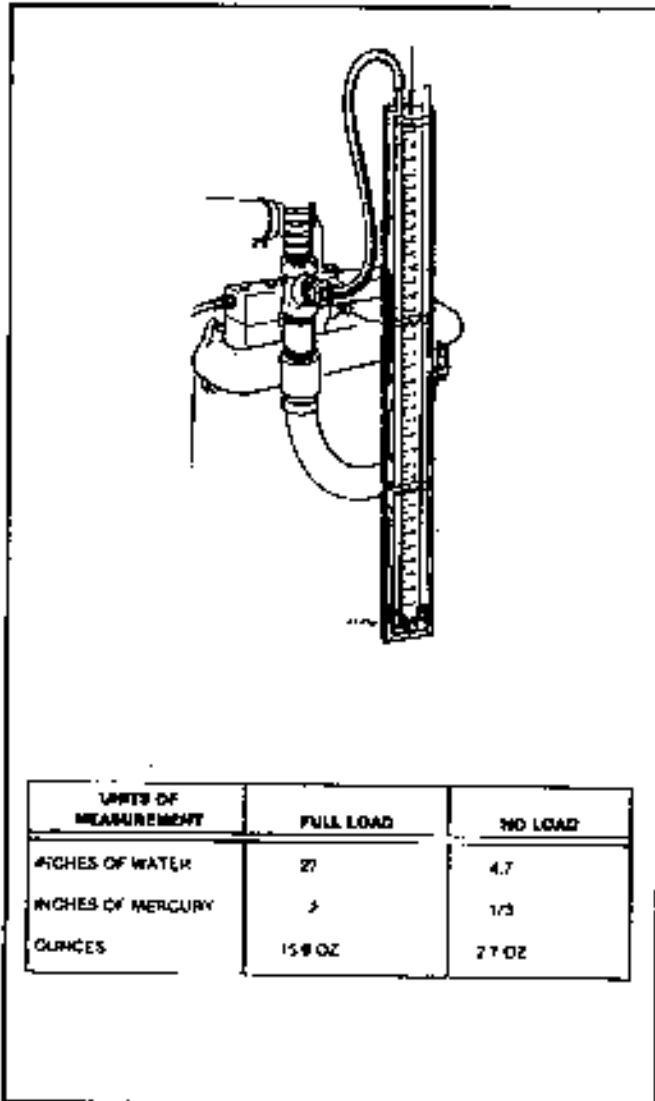

FIGURE 13-1. MEASURING EXHAUST BACK PRESSURE

Run the unit at full load and observe the manometer. (See Figure 13-1 for maximum values.) If the back pressure reading is higher than specified, disassemble and clean the exhaust system.

On units with factory installed exhaust systems, order replacement parts directly from your Onan distributor.

Fixed Location Exhaust System

Pipe exhaust gases outside any enclosure (Figure 13-2). Use pipe at least as large as the size of the outlet of the engine. Increase the pipe diameter one pipe size for each additional ten feet (3 m) in length. Use a flexible connection at the engine exhaust manifold. Provide adequate support for the piping.

Pipe fittings cause a resistance to the flow of exhaust gases and can result in a loss of engine power.

Use sweeping elbows in preference to standard pipe elbows, and keep the number of turns to a minimum. If the exhaust line runs upward at any point, install a vapor or condensation trap at the low point, with a provision for periodic draining (Figure 13-4). Shield or insulate the line if there is any danger of personal contact. If the line passes close to a combustible wall or partition, allow at least four inches (102 mm) clearance. If it passes through a combustible wall or partition, install a thimble as shown in Figures 13-2 and 13-4. Install a suitable muffler.

Mobile Installation

If the unit is permanently mounted, pipe the exhaust to a muffler mounted under the floor. If the unit is mounted on a slide-out tray, vent the exhaust through the air discharge duct. Flexible exhaust tubing (used between the unit and the muffler) absorbs unit vibration. If the exhaust line passes through a flammable floor or partition, insulate with asbestos-backed metal collars where it passes through these barriers. Exhaust lines may be asbestos wrapped to reduce heat radiation within the compartment.

Be sure flexible exhaust sections that are wrapped still retain their flexibility.

For all exhaust systems, support flexible lines and separate mufflers with automotive flexible tail pipe hangers. This eliminates exhaust noise transmission to the vehicle frame.

When installing mufflers other than those supplied with plant or, if the exhaust system is excessively complicated, check the exhaust back pressure (Figure 13-1). Exhaust back pressure at rated load, measured at the exhaust manifold, should not exceed three inches Hg. (76 mm) mercury column. Where a tapped hole is not provided, the manifold and/or a pipe coupling may be drilled and tapped. After measurement is made, plug the hole with an ordinary pipe plug.

Rev 10-75

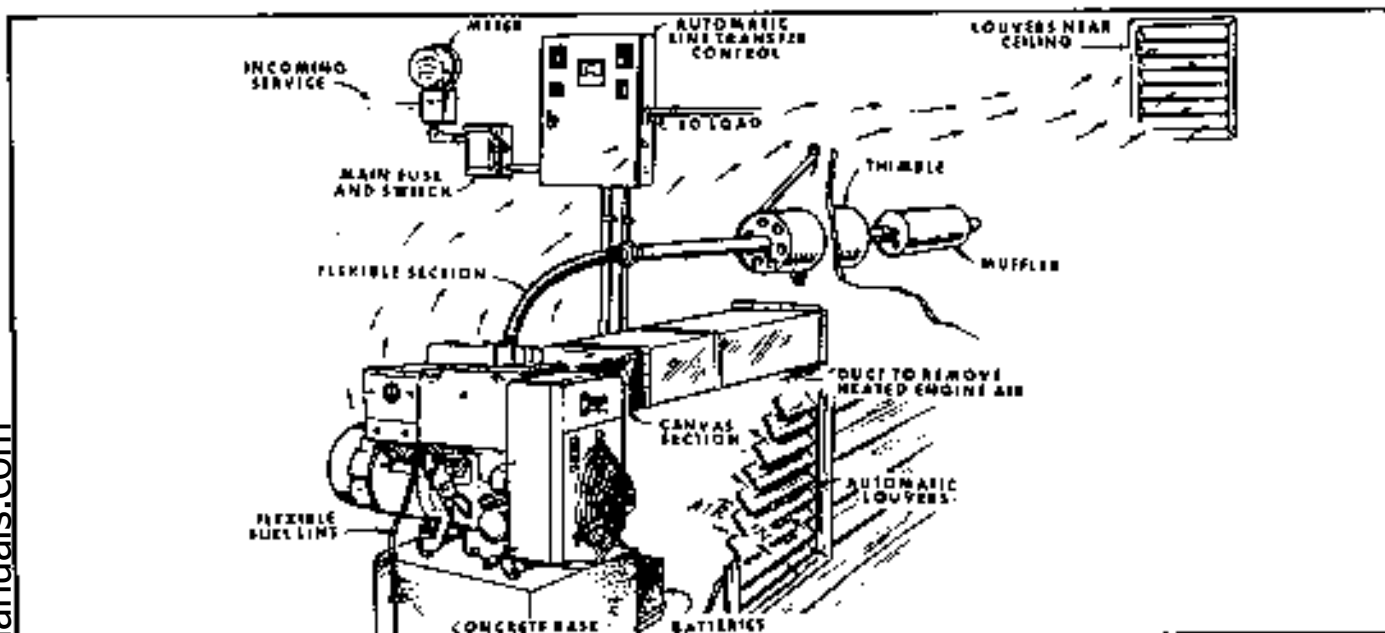

FIGURE 13-2. TYPICAL FIXED POSITION EXHAUST SYSTEM

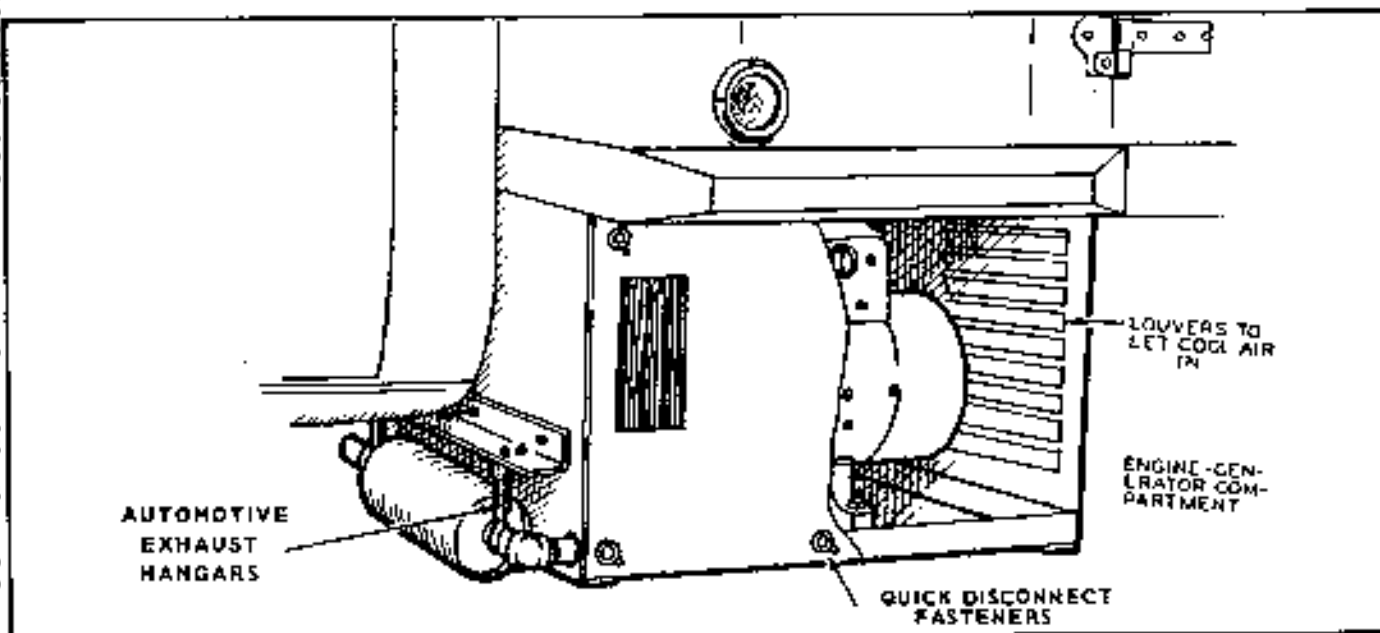

FIGURE 13-3. TYPICAL MOBILE INSTALLATION EXHAUST SYSTEM

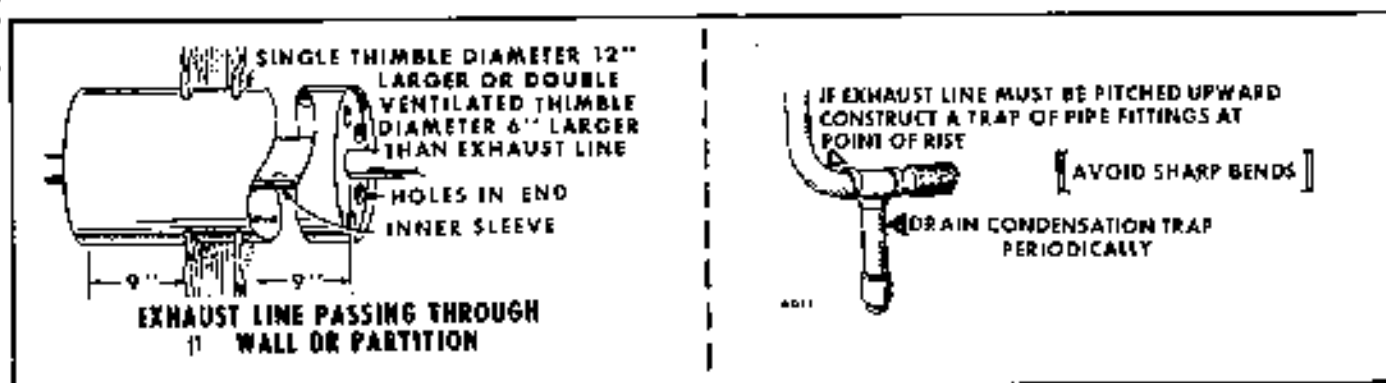

FIGURE 13-4. EXHAUST SYSTEM CONSIDERATIONS

MARINE UNIT EXHAUST SYSTEMS

Install all marine exhaust systems per Coast Guard regulations.

All exhaust systems for water cooled marine installations must meet these requirements:

- 1 Except for vertical dry stack systems, exhaust systems must be water cooled, the water to be injected as near to the plant as possible.
- 2 All exhaust system sections before the point of cooling water injection must be either water jacketed or effectively insulated.
- 3 The exhaust line must be installed so as to prevent back flow of water to the engine under any conditions and the exhaust outlet must be above the load waterline. Any water flowing back to the engine will damage it.
- 4 The exhaust system must not be combined with the exhaust system of any other engine.
- 5 Use an approved, flexible, non-metallic exhaust line section near the engine to allow for engine movement during operation.
- 6 Vertical dry stack exhaust systems must have spark arresters. The exhaust system between engine manifold and spark arrester must be either water jacketed or well insulated.

MATERIAL

Use exhaust line at least as large as the engine exhaust outlet (Table 13-1) but increase the entire line one pipe size for each ten feet (3 m) in length.

Either cast iron or wrought iron piping is recommended for exhaust lines. On gasoline installations, copper tubing is acceptable, providing it is approved for marine installation (wall thickness greater than .083 inch [2 mm]). On diesel exhaust systems, use copper tubing only for the water cooled section of line. Most

TABLE 13-1.
ELECTRIC PLANT EXHAUST OUTLET SIZES

PLANT MODEL	EXHAUST OUTLET SIZE
MAJ	3/4"
MDJA MDJB MDJE	1-1/8"
MDJC MJC MDJF	1-1/2"
MCKK	1"

installations today use flexible rubber hose for the water cooled section of the exhaust line because of the ease of installation and flexibility.

Be sure rubber hose used is designed for exhaust line use, such as heavy duty single braid reinforced rubber hose.

Provide adequate support for rubber hose to prevent sagging, bending and the formation of water pockets.

Install the flexible section of exhaust line between the engine and muffler (Figure 13-5). Do not connect the muffler directly to the exhaust manifold. Use rubber hose only in the water cooled sections of the exhaust system.

CAUTION Do not install rubber hose with sharp bends as this reduces efficiency and may cause eventual hose failure.

Metallic flexible line is not recommended except in below water line or dry pipe installations. When using metallic flexible exhaust line, install in straight lengths only.

EXHAUST COOLING WATER INJECTION

Cool the exhaust with the full electric plant cooling system water output. If a keel cooler is used (no water output), install a separate hull water inlet and use the

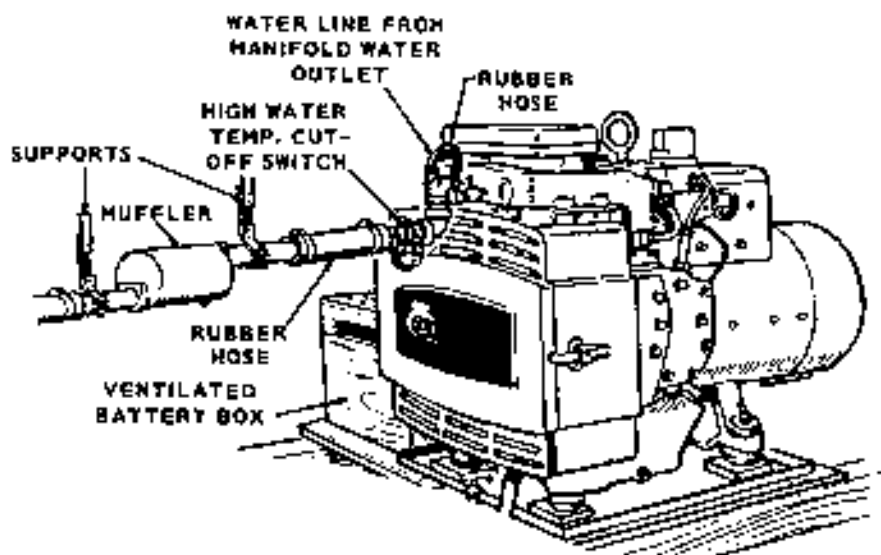

FIGURE 13-5. TYPICAL SMALL UNIT EXHAUST SYSTEM

Rev 10-75

TYPICAL INSTALLATION

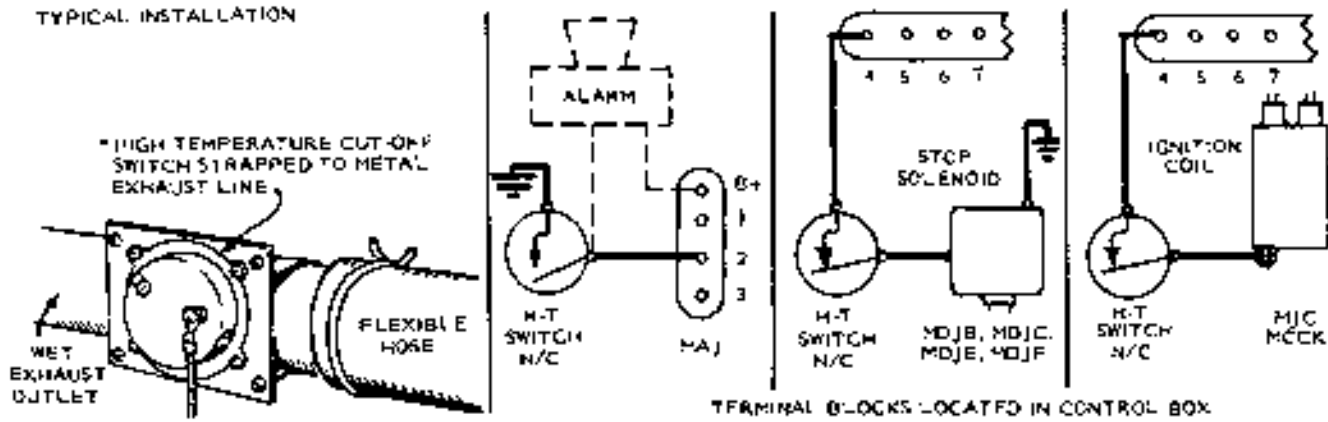

FIGURE 13-6. HIGH TEMPERATURE EXHAUST SHUTDOWN SWITCH

engine mounted neoprene impeller pump to provide exhaust cooling water. When installing a separate system to cool the exhaust, a device is required to indicate if the water fails. Mount a temperature operated switch on the exhaust line and connect it to operate either an alarm or to shut off the electric plant if the exhaust overheats (approximately 240°F [115°C]). Onan recommends high temperature exhaust shutdown switches for all types of marine installations (Figure 13-6).

One of the most important considerations of water injection is to keep the water from flowing back through the exhaust system into the engine. The two most frequent causes of water entering the engine are:

1. Momentum builds up by water sloshing in the exhaust line which causes the water to rush

forward into the engine when the boat pitches forward. This is especially true in installations where there is considerable length of straight exhaust line or where pockets allow water to gather. In most cases, you cannot install the exhaust line with enough downward pitch to prevent it from tilting toward the electric plant when the boat pitches, so a baffle of some type must be included in the exhaust line to prevent water from pouring into the engine.

2. Engine stopping creates a vacuum in the exhaust line. This could suck water back into the engine if the water was near enough. The vacuum results from two causes. On single cylinder diesel electric plants, the engine is stopped by a decompression mechanism that opens the exhaust valve. On other plants, the engine rocks against compression as it comes to a stop and, if an exhaust valve

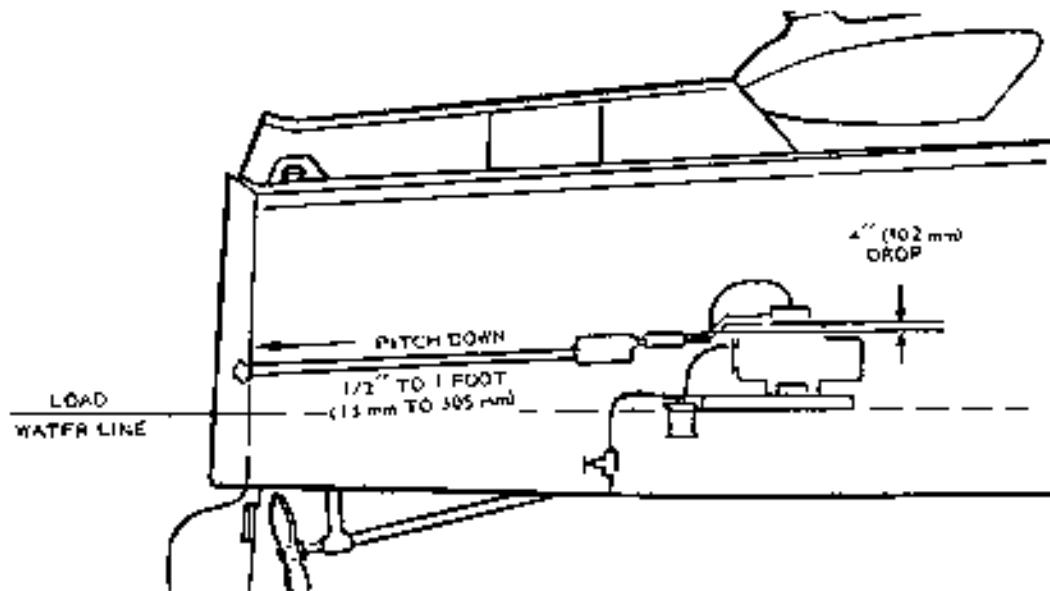

FIGURE 13-7. EXHAUST LINE INSTALLATION

WARNING: Inspect inject on exhaust elbows for corrosion, leaks and damage every 30 days.

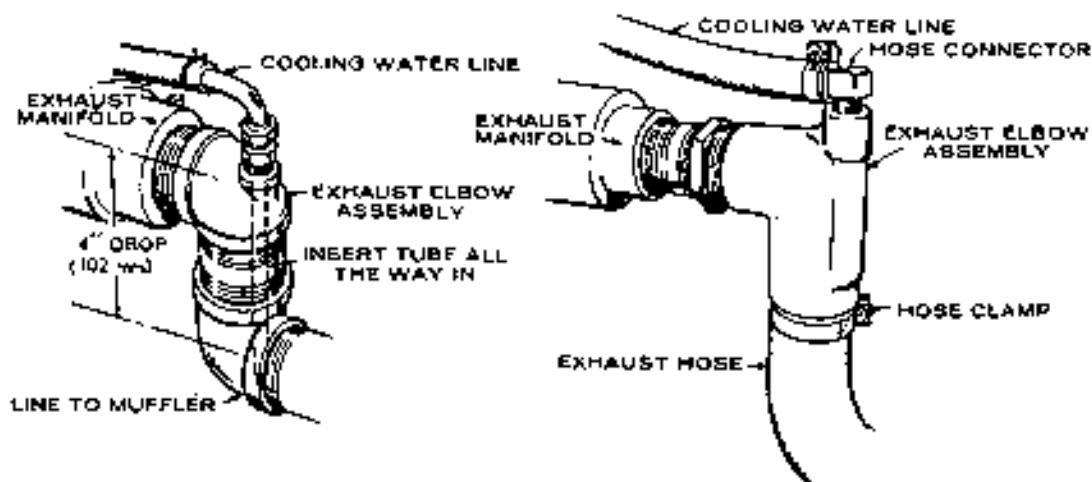

FIGURE 13-8. TYPICAL WATER INJECTION EXHAUST ELBOWS

is open, sucks a small amount of exhaust back into the cylinder.

There are several methods of eliminating water from the engine. All are based on separating the water injection point a few inches from the engine and installing a sharp drop in the exhaust line that water cannot normally overflow.

These methods are divided into two categories—above water line installation and below water line installation.

When installing an electric plant with the exhaust manifold one foot (305 mm) or more above the water load water line, inject the cooling water near the exhaust manifold. There are two kinds of exhaust elbows used. Most Onan marine units use a one piece

exhaust elbow while the rest use an elbow that has to be assembled (Figure 13-8). Make plumbing connections so cooling water is injected four inches (102 mm) below the manifold level.

For the exhaust elbow to be assembled, insert the water injection tube all the way.

As an alternative, some mufflers have an integral water inlet so water can be injected at the muffler and the muffler itself serves as an additional water barrier. Install this type of muffler as close as possible to the exhaust manifold, but with a section of flexible seamless metallic piping between muffler and manifold. Do not use the manifold as a muffler support; this puts excessive strain on the connecting exhaust line and can cause it to break.

When the electric plant is installed below or near the water line and an Aqualit muffler cannot be used

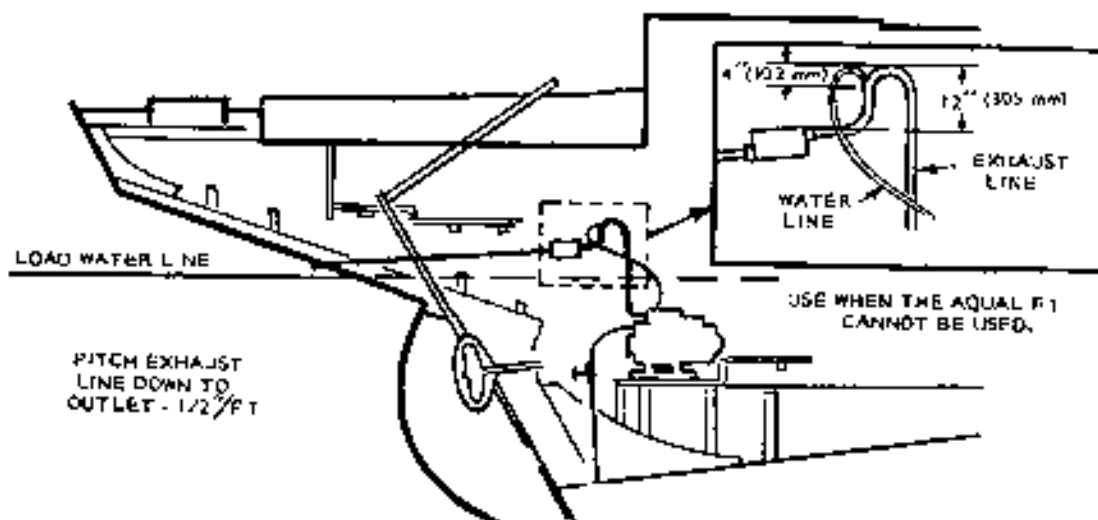

FIGURE 13-9. TYPICAL BELOW-WATER-LINE INSTALLATION, USING A RISER SYSTEM

Rev 10-75

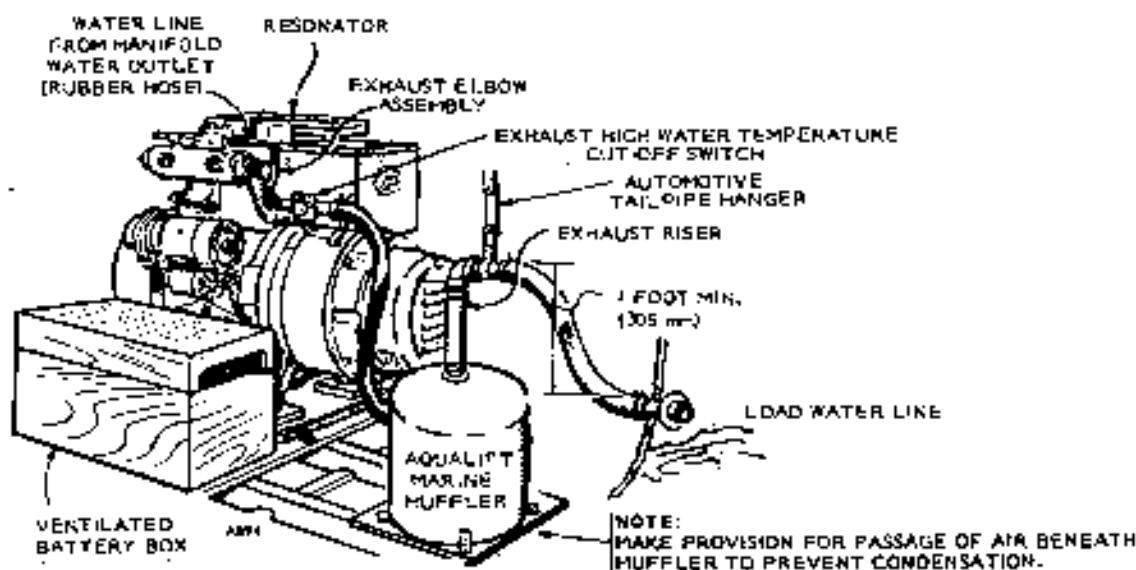

FIGURE 13-10. ABOVE-WATER-LINE INSTALLATION OF MDJB ELECTRIC PLANT

(Figure 13-9), the exhaust line must be run in a loop or hump above the water line to provide a water barrier and to raise the point of water injection above the water line (called a riser exhaust system). The higher point of the loop or hump should be at least 12 to 18 inches (305-457 mm) above the boat load water line (the higher the better). Inject exhaust cooling water on the outlet side of the hump and at least four inches (102 mm) below the bottom of the pipe at the top of the hump. When using this exhaust arrangement, install a condensation trap (Figure 13-10) as near the manifold as possible to catch any water condensing from the dry section of the exhaust line. Install either a valve or plug in the bottom of the trap to be drained at regular intervals.

To help break up the momentum of backwashing water in the exhaust line before the water backflows to the electric plant, install the muffler near the plant. Water rushing forward will pour into the muffler, dissipating its momentum.

EXHAUST LINE INSTALLATION

From the point where water is injected into the exhaust line, pitch the exhaust line downward toward its outlet with a slope of at least 1/2 in./ft (42 mm/m) of line. It allows draining during operation and also when stopped.

If possible, run the exhaust line without any dips or pockets. Low sections allow water to build up in the line, creating back pressure and noise. If there is a dip in the exhaust line, install a drain at the lowest point to drain the exhaust line for storage.

Water jackets for the dry section of exhaust line are usually specially made. Figure 13-10 shows a water jacket made for the hump of a below water level exhaust installation. The water jacket and hump were prepared from refrigeration type elbows.

The exhaust line should be as short as possible, with a minimum number of bends and gas tight throughout its length. Make the radius of any bend in the exhaust at least five times the diameter of the pipe. If metal piping is used, install either noncombustible hangers or blocks, such as automotive tailpipe hangers with vibration insulators to support it. Where the exhaust line passes through a non-watertight bulkhead, use a noncombustible packing.

Where exhaust lines pass through watertight bulkheads, the watertight integrity of the bulkhead must be maintained by installing graphite packing in stuffing tubes. In some cases, it will be to your advantage to run the exhaust line out the side of the boat, rather than out the transom as is normally done. This should be considered in cases where an excessively long line to the back of the boat could lead to water pocketing or excessive exhaust back pressure.

MUFFLERS

A marine muffler silences the electric plant. Some mufflers have provision for an exhaust line water inlet; others are cooled by water through the exhaust line (Figure 13-5). Onan recommends the highly efficient Aqualift muffler for electric plants (Figures 13-10 and 13-11) installed above or below the load water line.

CAUTION If the exhaust manifold of the engine is below the load water line, install the siphon break kit listed in the Aqualift installation instructions.

Follow any special installation instructions included with the muffler or electric plant. Placement in the exhaust line, of course, depends on the kind of muffler used, but always leave some tailpipe to improve silencing. Install the Aqualift muffler as near as possible to the electric plant. Inject exhaust

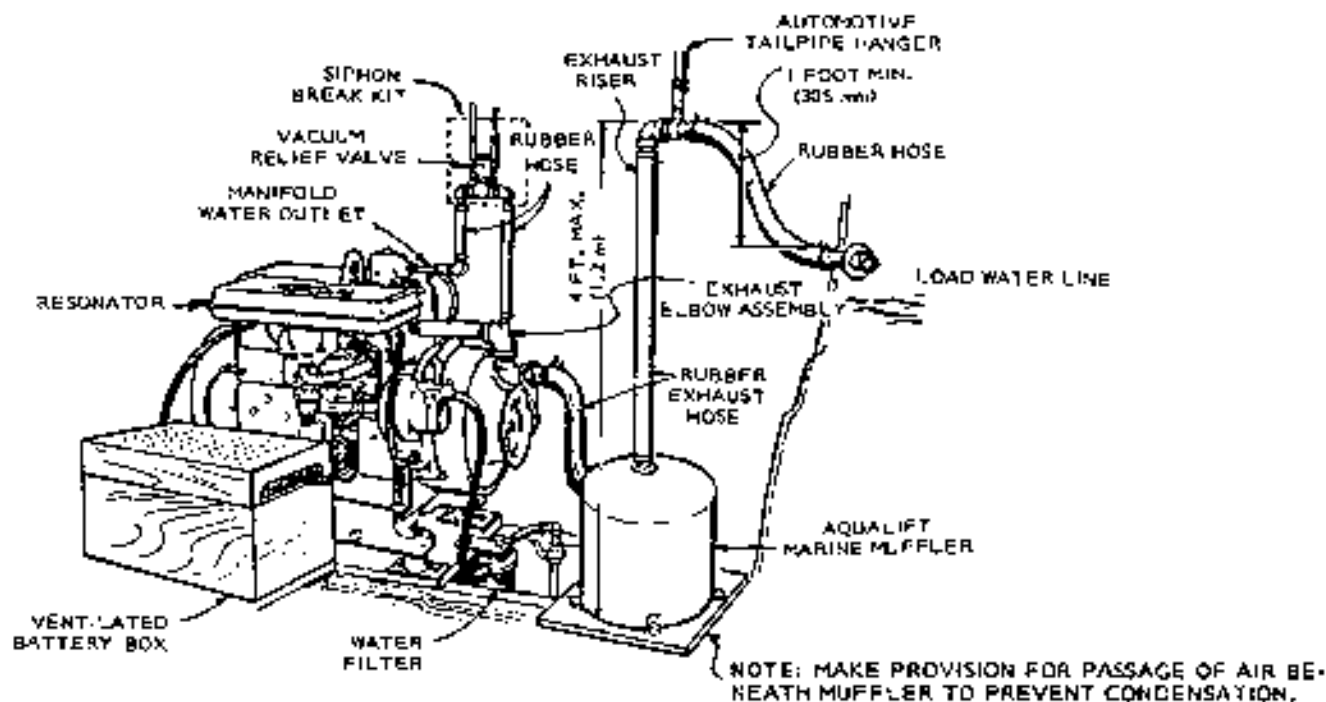

FIGURE 13-11. BELOW-WATER-LINE INSTALLATION OF MAJ ELECTRIC PLANT

cooling water at or before the muffler. If a neoprene muffler is used, install it near the plant but at least two inches (51 mm) after the water inlet to the exhaust line. Always leave at least 3 inches (76 mm) of exhaust line between a neoprene rubber muffler and engine.

Be sure any muffler is well supported and, in the case of a neoprene muffler, completely separated from the vessel's structure. If a neoprene muffler touches the vessel, it increases exhaust noise.

Aqualift Marine Muffler Installation

The Aqualift is a highly efficient marine muffler designed for above or below water line installations when water cooled exhaust systems are used. Because of installation variables, customers must provide the brackets, hoses and clamps required for installation.

Use only a flush type thru hull fitting. The strainer supplied is specifically for use with the Aqualift muffler. Install with the slots parallel to the keel. Do not use a hole type strainer in place of the Onan slotted strainer. If a hole type is used, suction pressure could be too great for the engine water pump to overcome.

DO NOT USE SCOOP TYPE WATER INLET FITTINGS when installing an Aqualift muffler with a marine electric plant. Forward

facing scoops develop sufficient ram pressure to force water past the plant's water pump, flooding the exhaust system where it may flow back, flooding the engine cylinders. This can happen only if the electric plant is not running and boat is underway.

Considerations Before Installation of the Aqualift Muffler

1. Nipple size must be the same as the engine exhaust manifold outlet. Exception. MAJ Series is 3/4 inch.

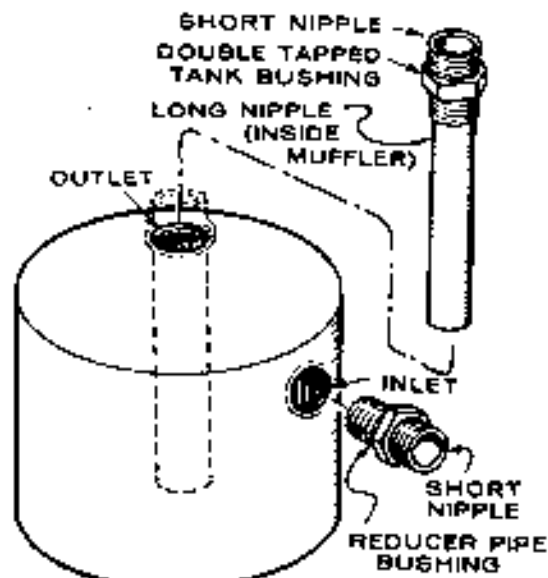

NOTE: LONG NIPPLE GOES INSIDE TANK

FIGURE 13-12. TANK AND NIPPLES

TABLE 13-2. PIPE FITTING PACKAGES

MODELS	PIPE SIZE	USE HOSE I.D.
MJC, MDJC, MDJF	1-1/2	2
MJB, MDJB, MDJE, MDCK	1-1/4	1-5/8
MAJ	1	1-5/16

Typical nipple sizes:

- Four cylinder J Series..... 1-1/2"
- One and two cylinder
J Series and MCOCK 1-1/4"
- MAJ Series 1"

2. The Aqualift muffler requires special fittings for proper installation and operation.
3. The muffler must be installed within ten feet (3 m) of the engine exhaust outlet.
4. There must be a pitch of one half inch (13 mm) per foot (i.e., a 2-1/2 inch [63.5 mm] drop for a five foot [1.5 m] run) in the exhaust tubing between the engine exhaust elbow and the muffler inlet. Muffler may be mounted below the level of the engine if necessary.
5. Select a location where the muffler can be fastened to a sturdy base with the outlet in a vertical position.
6. The distance from the base of the muffler to the upper elbow on the exhaust tubing from the muffler outlet must not exceed four feet (1.2 m), Figure 13-15.
7. A minimum drop of one foot (25.4 mm) is necessary between the upper elbow above muffler outlet and the exhaust outlet on the hull to prevent water from washing into the system (Figure 13-15).
8. Position the exhaust outlet on the hull so that a minimum of water will enter while at anchor or under way.
9. An increase of one standard pipe size for every ten running feet (3 m) of exhaust from the muffler to the exhaust outlet is necessary to prevent excessive back pressure.

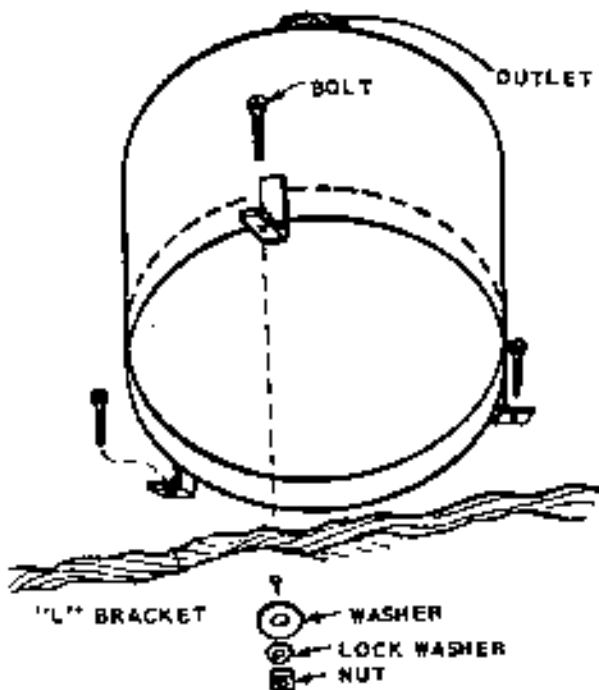

FIGURE 13-13. MOUNTING TANK

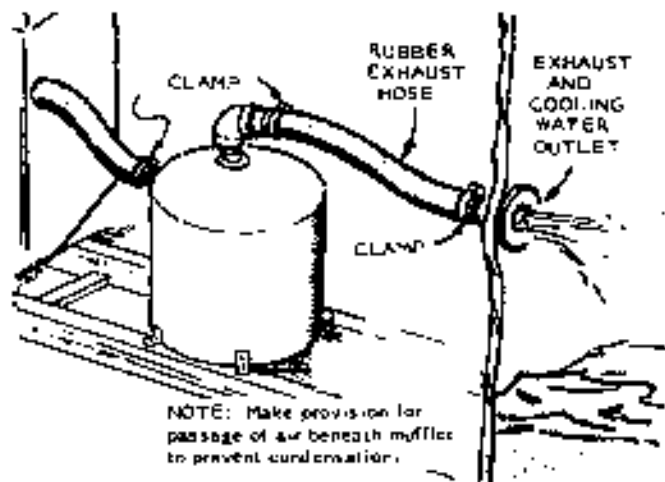

FIGURE 13-14. ABOVE-WATER-LINE INSTALLATION

CAUTION Welding on the muffler damages the interior protective coating, decreasing muffler life.

INSTALLING THE AQUALIFT MUFFLER

1. Secure the muffler to the predetermined location using the "L" brackets on the Aqualift muffler.
2. Connect the exhaust line to the marine elbow on the engine and to the exhaust inlet on the muffler.
3. Connect the exhaust line to the muffler outlet and to the upper elbow. Use a conventional automobile tail pipe hanger bracket to hang the upper elbow. Rigid pipe may be used in place of flexible hose for certain applications. See Figures 13-14 and 13-15.
4. Connect the exhaust line from the upper elbow to the exhaust outlet on the hull.

CAUTION Be sure all fittings are tight.

5. Start engine and check for leaks.

CAUTION Install Siphon Break Kit 155-0950 if exhaust injection elbow is below water line. Locate the siphon break at least 12 inches (305 mm) above load water line and in a vertical position. Remote mounting of the siphon break is permissible within a five foot (1.5 m) radius of water injection exhaust elbow. Maintain vertical position and height of valve. See Figure 13-15 for typical below water line installation.

Figure 13-16 illustrates a typical Aqualift installation on a MCOCK generating set.

Rev 10-75

Do not use scoop type water inlet fittings on electric plants using Aqualift muffler systems.

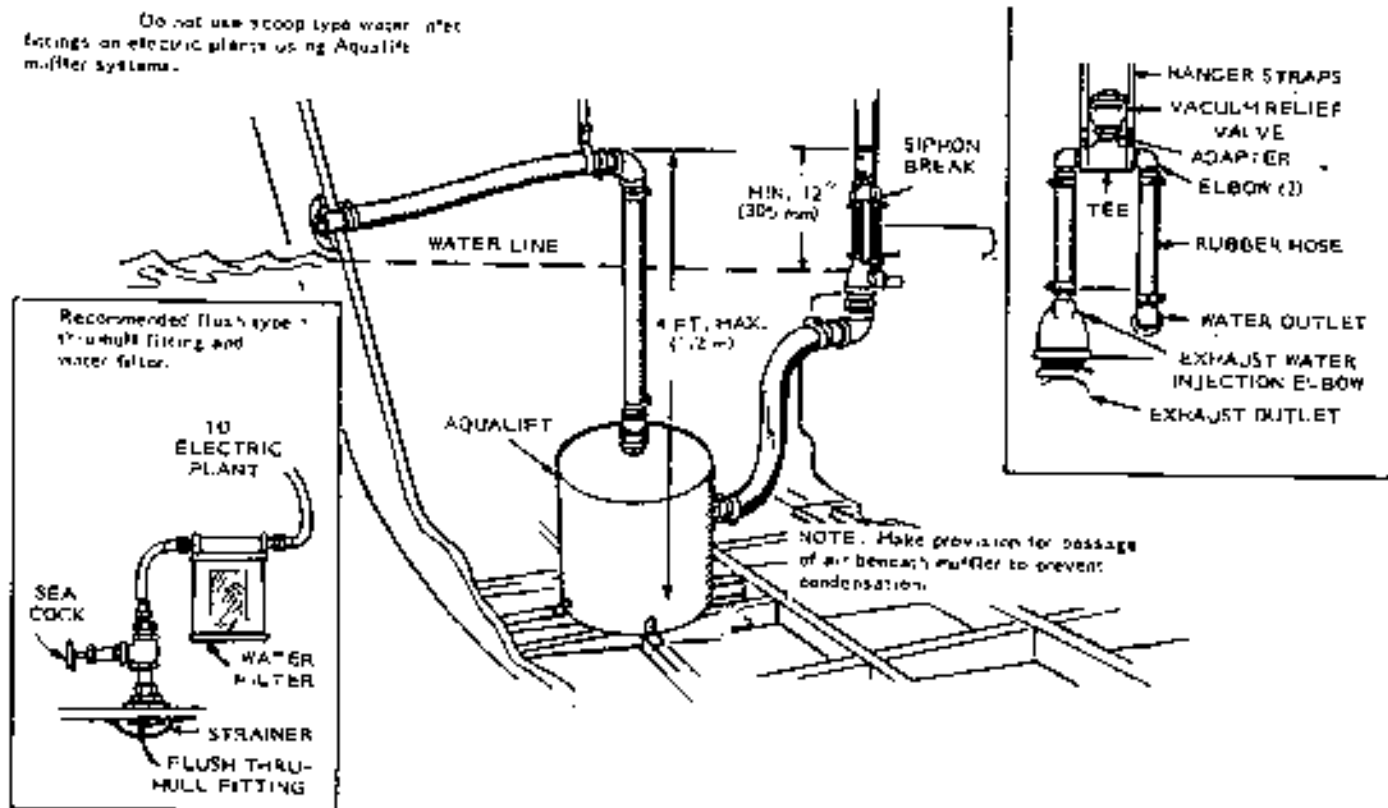

FIGURE 13-15. BELOW-WATER-LINE INSTALLATION

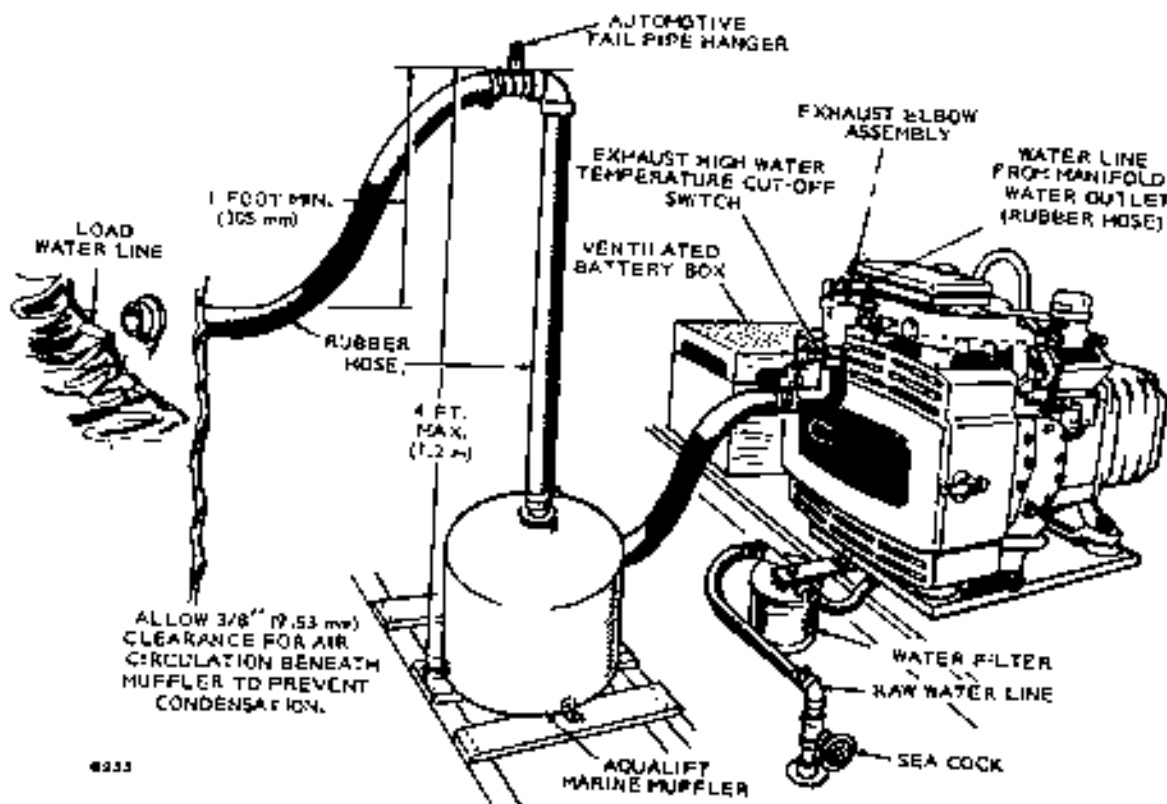

FIGURE 13-16. INSTALLATION USING AQUALIFT MARINE MUFFLER

Rev 10-75

SECTION 14.

GENERAL ENGINE DISASSEMBLY/ASSEMBLY

INDEX

GENERAL.....	14-1
DISASSEMBLY.....	14-1
PARTS CARE.....	14-1
ASSEMBLY.....	14-1
OPERATION.....	14-2
BREAK-IN PERIOD.....	14-2
FLYWHEEL REPLACEMENT.....	14-2
FLYWHEEL MARKINGS—DIESEL ENGINES.....	14-2
Port Closing.....	14-2
FLYWHEEL MARKINGS—GASOLINE AND GAS ENGINES.....	14-2
FLYWHEEL MARKINGS—TWO CYLINDER OPPOSED PISTON ENGINES.....	14-2
FLYWHEEL REMOVAL (Similar on all engines).....	14-2
RING GEAR.....	14-3
GEAR COVER.....	14-3
Governor Shaft.....	14-3
Gear Cover Oil Seal.....	14-3
Assembly, Gear Cover.....	14-4
CLEANING AND INSPECTING PARTS.....	14-4
Cleaning and inspecting.....	14-4
Hand Cleaning.....	14-4
Cold Spraying.....	14-5
Hot Tank Immersion.....	14-5
Cold Tank Immersion.....	14-6
Steam Cleaning.....	14-6

For detailed information on the Onan industrial engines, refer to the appropriate Service Manual for each engine listed below.

BF	965-0250
BG	965-0251
CCK	927-0253
CCKA	927-0253
CCKB	927-0404
DJBA	967-0423
DJB-DJC	967-0250
JB-JC	967-0462
NB	940-0401
NH	940-0402
NHA-V	940-0403
NHB-V	940-0403
NHC-V	940-0251
NHP-NHPV	940-0250
RCCK	927-0252
RDJE/RDJEA	974-0250
RDJF	974-0251

GENERAL

When complete engine disassembly is necessary, first remove all complete assemblies. Individual assemblies like fuel pump and carburetor can be disassembled and repaired at another time. Refer to various sections for detailed information.

Illustrated, step-by-step disassembly procedures are given in the following Onan Engine Training Manuals:

BF	932-0400
CCK	932-0401
NH	932-0403
J-Series Diesels	932-0407

Refer to *TOOLS* Section 19 for special tools.

DISASSEMBLY

Common sense dictates the order of disassembly and assembly.

The suggested disassembly procedure is as follows:

1. Drain crankcase and cooling system on liquid cooled models.
2. Disconnect all exhaust lines and electrical lines.
3. Remove all housings, shrouds, blower housings, air cleaner, control box, etc.

When removing control box, tag all wires according to their respective locations.

5. Remove flywheel, using a puller or pry-bar method.
6. Remove gear cover, being careful to protect oil seal from keyway damage.
7. Remove crank gear, using a gear puller and ring.
8. Remove all accessories such as fuel pump, oil filter, starter, generator, carburetor, gasoline or diesel fuel lines, spark plugs, etc.
9. On diesel engines remove injection pump, injectors, glow plug, etc.

10. Remove distributor.
11. Remove oil base, oil pump and cylinder head.
12. Remove valves, springs, rocker arm, lifters, etc.
13. Remove camshaft and gear assembly.
14. Remove connecting rods, pistons and bearings.
15. Remove center main bearing if applicable.
16. Remove rear bearing plate.
17. Remove crankshaft.
18. Remove front main bearing.

PARTS CARE

Keep all parts in their respective orders. Keep valve assemblies together. Return rod caps to their respective pistons. Analyze the reasons for parts failure. See specific sections of this manual covering dimensions of parts, tolerance and wear limits, specific engine data, etc.

ASSEMBLY

The engine assembly procedure is normally the reverse of the disassembly procedure, observing proper clearances throughout the engine. Use a torque wrench to assure proper tightness. Coat the internal engine parts with oil as they are assembled. After the internal engine parts are assembled, the crankshaft should rotate by hand freely. Use only genuine Onan parts and Onan tools when reassembling your engine.

1. Use proper bearing driver to install front main bearing after coating it with a light film of oil.
2. Insert rear main bearing in rear bearing plate.
3. Install crankshaft and rear bearing plate.
4. Install the center main bearing and bearing cap if applicable.
5. Install connecting rods, pistons and bearings.
6. Install camshaft and gear.
7. Install valve assemblies.
8. Install oil pump, oil base and cylinder head.
9. Install distributor.
10. On diesel engines install injection pump, injection nozzles, glow plugs, etc.
11. Install all accessories such as fuel pump, oil filter, starter, generator, carburetor, gasoline or diesel fuel lines, spark plugs, etc.
12. Install crank gear, aligning crank gear mark with cam gear mark.
13. Install gear cover and oil seal.
14. Install flywheel.
15. Install all housings, air cleaner, control box, etc.
16. Fill crankcase with oil and fill cooling system if applicable.

OPERATION

1. Start engine.
2. Check oil pressure.
3. Run engine about 15 minutes to bring up to operating temperature.
4. Check for oil leaks, exhaust leaks, loose electrical connections, tight fuel lines and tight exhaust connections.
5. Adjust governor for speed and sensitivity.

BREAK-IN PERIOD

Whenever new rings or pistons are installed or the cylinders are refinished, the engine must be run-in before regular operation can be resumed. Run the engine for 15 to 20 minutes at no load, about 30 minutes at 1/3 load, and 2 to 3 hours at 2/3 load. Regular operation can then be resumed. Avoid light load operation during the following several hours for best ring seating to control oil.

FLYWHEEL REPLACEMENT

Some replacement flywheels may be supplied without the timing markings. In that case, the flywheel must be fitted to its engine. The only accurate method of determining the top dead center (TDC) and port closing points is to measure the piston travel. This is a critical measurement and should be attempted only with accurate, dependable equipment.

1. With flywheel mounted, remove head and install a depth gauge over front piston.
2. Rotate flywheel to find the TDC position on the compression stroke and mark this point on the flywheel.

FLYWHEEL MARKINGS— DIESEL ENGINES

The flywheels on Onan J-series diesel engines are stamped at the Top Center (TC) and Port Closing (PC) positions at the factory assembly line. The TC mark is established, before the head is installed, with the No. 1 piston at Top Dead Center (TDC) on a compression stroke so the TC mark aligns with the timing pointer on the gear cover. The PC mark is established at the same time by rotating the flywheel counterclockwise from TC so the piston drops exactly .128 inch (3.251 mm) on the 2- and 4-cylinder engines and .102 inch (2.591 mm) on the 1-cylinder engines. White paint marks are also added at the TC and PC markings to make them easier to locate.

The timing pointer on all J-series engines is molded as a part of the gear cover. On vacu-flo engines, an other timing pointer is mounted on the left side of the block below the gear cover. A dot button hole is used to view these timing marks and pointer.

The exact timing for the fuel injection pump is established by measuring the shim thickness required for mounting the injection pump which is then installed. The proper shim thickness is stamped on

the engine block above the pump mounting boss and the timing button code number is stamped on the pump flange.

Port Closing

The port closing position occurs at 19° before TDC on the 2- and 4-cylinder diesels and at 17° before TDC on the 1-cylinder diesels.

On 2- and 4-cylinder diesels prior to Spec P (1966), the piston drop for PC was measured at .155 inch (3.937 mm); port closing occurred at 21° before TDC.

All replacement flywheels are also stamped before shipment from the factory to indicate the proper TC, PC, and other of the required timing marks.

FLYWHEEL MARKINGS—GASOLINE AND GAS ENGINES

The flywheels on Onan J-series gasoline and gaseous fuel engines are stamped at TC and 10°, 25°, and 35° BTC positions at the factory. A jig fixture is used to locate the markings exactly. White paint marks are also added along with the stampings at the TC and 25° positions for gasoline engine timing while yellow paint marks are added at the 10° and 35° positions for gaseous fuel engine timing.

On vacu-flo engines, the TC and other timing marks are offset from normal position 95° and a dot button hole is used for viewing the timing marks and pointer.

FLYWHEEL MARKINGS— TWO CYLINDER—OPPOSED PISTON ENGINES

The flywheel markings on the Onan opposed piston engines vary somewhat in that timing occurs at different degrees before TDC for one reason or another. In each case, the TC mark and maybe one or more timing positions (degree marks) are stamped on the flywheel at the factory. The timing marks (TC and 0° to 25°) are embossed on the gear cover. The timing marks on vacu-flo engines are located for use with a dot button hole and pointer. Refer to IGNITION Section 10 for specific engine timing procedures.

FLYWHEEL REMOVAL J-SERIES (Similar On All Engines)

1. Remove all housings. The flywheel has a tapered fit on the crankshaft. Use the flywheel puller referenced in the tool catalog in this manual.
2. Loosen flywheel mounting screw (Figure 14-1) a few turns.
3. Place the flywheel puller bar against flywheel screw and attach bar, using two 3/8-16 thread screws, in the holes in the flywheel.
4. Alternately tighten the screws until flywheel is free.

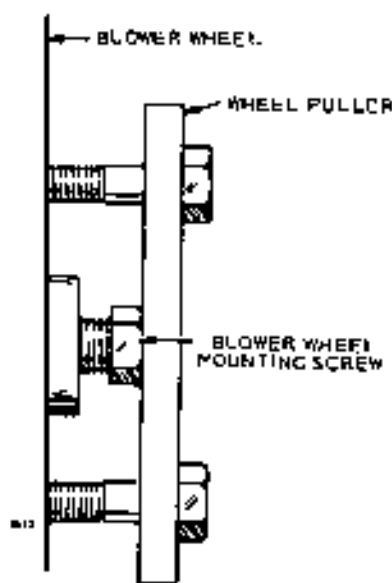

FIGURE 14-1. FLYWHEEL REMOVAL

RING GEAR

To remove the ring gear, if damaged, saw part way through, then break it using a cold chisel and heavy hammer, Figure 14-2.

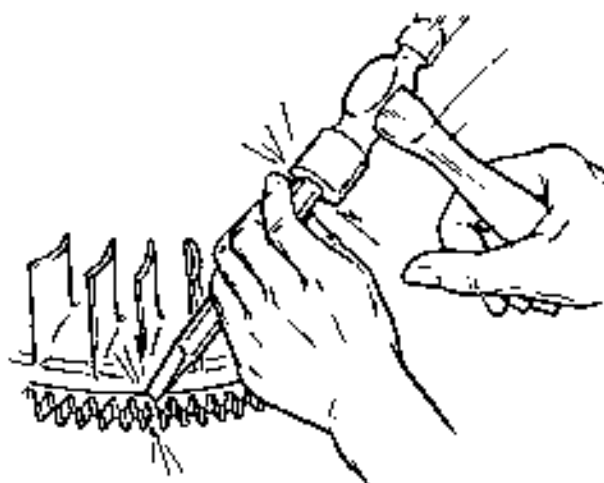

FIGURE 14-2. RING GEAR REMOVAL

To install a new ring gear, place it in an oven heated to 380° F — 400° F for 30 to 40 minutes.

CAUTION Do not heat ring gear with a torch because uneven application of heat can warp it.

When heated properly, the ring will fall into place on the flywheel. If it does not go on all the way by itself, drive it into place with a hammer. Do it fast and do not damage the gear teeth. The ring will contract rapidly and may shrink to the flywheel before it is in place. If this occurs, a new ring gear may be required.

GEAR COVER

To remove the gear cover, detach the upper governor ball joint. Remove the governor speed adjustment nut and governor spring bracket.

Remove the screws holding the gear cover to the crankcase. To loosen the gear cover, tap it with a soft hammer.

Governor Shaft

The governor shaft is supported by two sets of needle bearings. To remove the shaft, remove the yoke and pull the shaft from the gear cover. If the shaft is binding, clean the bearings. If loose, replace the bearings. To remove the larger bearing, drive both bearing and oil seal out from the outside of the gear cover. Remove the smaller bearing with an Easy-Out or similar tool. Press new bearings and oil seal into place.

Gear Cover Oil Seal

Replace the oil seal if damaged or worn. Drive the old seal out from inside the gear cover. Lay the cover on a board so the seal boss is supported. Using an oil seal driver, insert the new seal from the inside with rubber lip toward outside of gear cover (open side of seal inward) and drive it flush with the outside surface. During gear cover installation, use the driver to protect the oil seal, Figure 14-3.

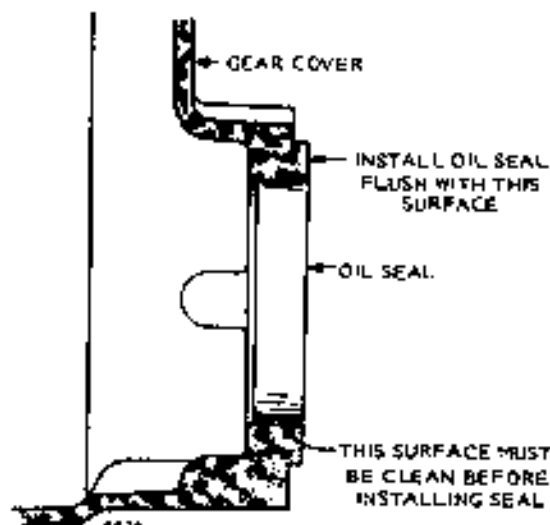

FIGURE 14-3. PROTECTING THE OIL SEAL

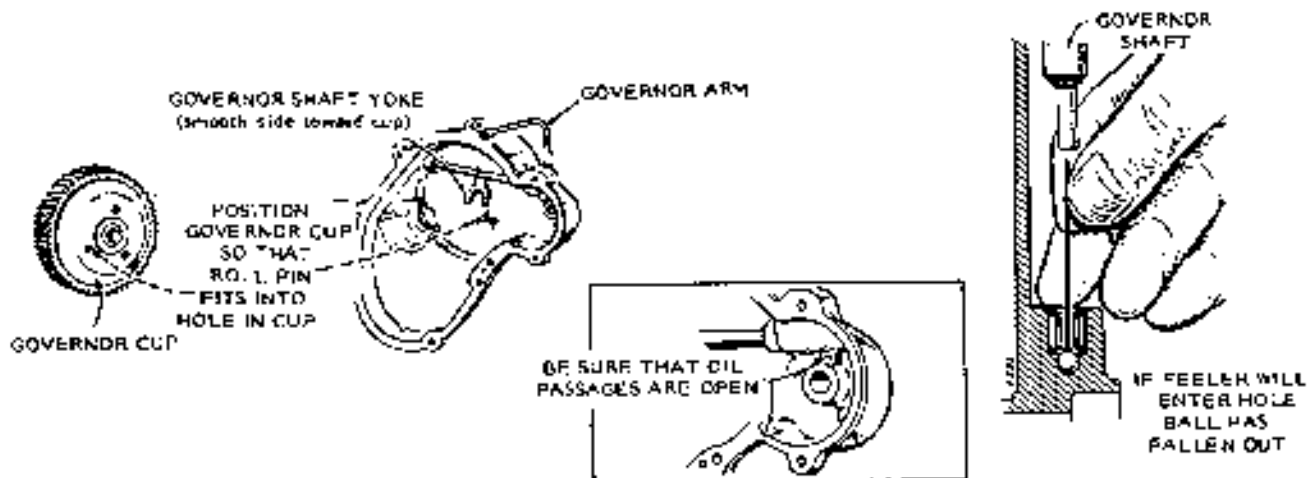

FIGURE 14-4. GEAR COVER ASSEMBLY

Assembly, Gear Cover

1. Work governor shaft to check for binding and see that governor shaft end-thrust ball is in place. Figure 14-4. Later models have a larger ball which will not fall out.
2. Turn governor yoke so smooth side is toward governor cup.
3. Turn governor cup so stop pin in gear cover will fit into one of the holes in cup surface, Figure 14-4.
4. Measure distance from end of stop pin to mounting face of cover. It should be 3/4 inch (19 mm). If it is not, replace the pin. Pin should be positioned with open end facing crankshaft seal.
5. Coat oil seal lip with oil or grease.
6. Set a piece of shim stock over crankshaft keyway to protect seal and install gear cover.
7. Tighten the mounting screws to 15 to 20 ft. lbs. Before tightening screws, be sure the stop pin is in the governor hole.

CLEANING AND INSPECTING PARTS

Clean parts are essential to proper inspection when overhauling an engine. A thorough inspection cannot be made unless all surfaces are cleaned of grease and dirt which might hide defects. After cleaning, each part must be inspected carefully and measured to determine the amount of wear that has occurred. New parts must be used to replace those which have been worn beyond allowable limits.

Cleaning and Inspecting

To avoid mixing parts, each of the subassemblies just removed will be disassembled, cleaned, inspected, and reassembled separately. It is possible that every subassembly need not be taken apart. If accurate troubleshooting has located the defective unit, only that assembly needs to be overhauled.

Wash parts in solvent and dry with compressed air. Do not use cloth to dry parts because of the danger of leaving lint in one of the passageways. In every case, gaskets, shaft seals, and "O" ring seals should be replaced to minimize the chances of leaks.

Blow-by and dirt unite with the oil to form sludge. The engine must be cleaned so that the newly installed parts will not be worn unduly because of the abrasives in the sludge.

The fact that an engine runs does not prove that it has been serviced properly. Every precaution should be taken to be sure that the engine parts are cleaned of all dirt, grit, and abrasive; dirt and grit are the primary causes of wear in any engine.

Cleaning of parts is accomplished in several different ways, depending on the equipment available. Five basic methods of cleaning parts are:

- hand cleaning
- cold spraying
- hot tank immersion
- cold tank immersion
- steam cleaning.

Three types of deposits which cleaning chemicals are called on to remove are: grease, carbon, and scale. No one chemical can do all three of these jobs, but two chemicals may be mixed to remove carbon and grease. Rust and scale require a special agent.

Hand Cleaning

Many parts of the engine are cleaned best by hand, especially where the block is not removed from the chassis. Carbon deposits are usually scraped by hand scrapers or with a wire brush. Soft metal parts, such as bearings, should be washed in cleaning solvent. Parts containing leather or impregnated material diaphragms must not be cleaned in tank solutions containing caustic alkalis.

Wire-Brushing Carbon: A solid core brush is used to clean the cylinder head, the top of the block, and the piston heads, while a flare-type wire brush is used for the upper cylinder walls and the recessed valve ports. An electric drill is used to drive the brush, which must be used lightly on aluminum heads and pistons to avoid scoring. It is generally necessary to use a small screwdriver to remove carbon deposits from pocket areas which otherwise would form an insulator and prevent heat from transferring readily into the coolant.

Valves: Hold each valve firmly against a revolving wire brush. Be sure that all carbon and especially gum are removed and not merely burnished. Heavy accumulations under the head can be removed by chipping off the carbon with a heavy screwdriver or a scraper.

Valve Guides: Valve guides require very careful cleaning. Carbon and gum left in the guide will deflect the pilot and result in inaccurate work. Any remaining gum will cause the valve to stick, which will burn the valve face and seat. Using an electric drill and the correct size guide cleaning tool, run the cleaner up and down the full length of the guide. A few drops of lacquer thinner from an oil can will help to dissolve the gum and the carbon. Pay special attention to the top of the guide to reveal any irregularity which might cause the pilot to seat improperly when reconditioning the valve seat.

Carbon and gum are removed from the valve head and stem by means of a wire brush. Be sure that the gum is removed completely, not just burnished onto the stem.

Valve Springs: Clean the valve springs, keepers, and spring retainers in cleaning solvent. Do not use any cleaner which will remove paint, as the springs are painted to prevent corrosion. Count the number of springs and associated parts before and after cleaning to prevent loss and consequent trouble in the final assembly.

Pistons: Pistons can be cleaned in a good carbon-removing solution after which the carbon is removed by scraping. The ring grooves must be cleaned of all carbon. The best device to do this is a ring groove cleaning tool. The width of the blade must be the same as the width of the ring. In case no tool is available, an old piston ring can be broken in half, and the resulting sharp edge will do an excellent cleaning job.

CAUTION

Be very careful not to damage or nick the sides of the ring groove, as this surface must be perfectly flat to assure a seal against the new ring.

Clean out the oil return holes with a drill the same size as the original holes.

Oil Lines: Clean all oil lines with solvent under pressure and finally with compressed air to be sure that they are open. Oil lines which operate under low pressure may sludge to the point where no oil will flow. These lines must be removed to be cleaned properly.

Oil passageways in the crankshaft can be cleaned by using a small wire brush. It is especially important to clean these holes after reboring and honing because grinding chips and abrasives find their way into them and are carried into the new bearings by the lubricating oil. Unless removed, they embed themselves into the bearing metal and scrape grooves in the crankshaft.

Cold Spraying

The outside of an engine can be cleaned by cold spraying. The chemical is sprayed over the engine and the loosened grime washed off with water. The chemical softens the dirt and loosens the bond. The grime and the grease are removed by flushing with a hose.

Spray the solvent all over the engine. Work it in with a stiff brush if the dirt is caked heavily. Allow it to stand for about 15 minutes, and then flush away with a pressure rinse. The more pressure used, the better.

Quicker results are obtained if the engine is run until hot before spraying. Protect the distributor, coil, starter, and generator with rubber hoods during spraying and rinsing. Sections of old inner tubes are excellent. Dry by running the engine after rinsing.

Hot Tank Immersion

Where available, a hot immersion tank is one of the most efficient and economical means of cleaning parts. The work is placed in the hot solution and the cleaning goes on while the mechanic is busy on actual repair work.

Soft metals, such as aluminum, babbitt, etc., should not be placed in the hot tank because the heavy-duty type cleaners usually attack these softer metals. Agitating the parts or the solution makes cleaning more effective. A hot tank, using a caustic solution, removes most types of soil. The parts should be rinsed with a high-pressure water hose after cleaning.

WARNING

Alkaline compounds must be handled with a scoop instead of your hands. Care must be taken in introducing these compounds into hot tanks to avoid boil-overs. Add the material to the water—never the water to the material! Pour the chemicals slowly to be sure that they all dissolve; stir if necessary.

Never introduce heavy-duty type materials into a full tank of hot water—fill the tank partially with cold water, add the materials, then fill the rest of the tank with hot water. In all cases, add the materials slowly.

Cold Tank Immersion

Large cold tanks are generally used for degreasing and decarbonizing smaller parts such as fuel pump and carburetor parts.

For cleaning of large parts, agitation-type tanks are more efficient than static tanks. The more agitation, the quicker and the more thorough the cleaning action.

The purpose of chemical cleaners is to loosen the deposits, not to remove them. Detached grime contaminates the solution. As soon as carbon and paint have been loosened, the work should be removed and rinsed with a hose.

Steam Cleaning

Steam cleaners get their name from the fact that steam is used to generate pressure and is also a by-product of heating the cleaning solution. Steam itself has little cleaning power. It will loosen some soils, but it does not dissolve them, break them up, or destroy their clinging power. Rather good machines generate as little steam as possible. Modern surface cleaning depends on a chemical solution to dissolve dirt, destroy its clinging power, and hold it in suspension. Steam actually hinders such a solution, but heat helps its physical and chemical action. Cleaning is most efficient when a hot solution reaches the work in heavy volume.

SECTION 15.

CYLINDER HEADS AND VALVES

INDEX

GENERAL	15-1
GENERAL INFORMATION	15-1
Carbon	15-1
Corrosion and Wear	15-1
Valve Head Margin	15-2
Misalignment	15-2
Width of Seat	15-2
Locating Valve Contact Area	15-2
Interference Angle	15-3
Stems and Guides	15-3
Gaskets	15-3
Bolting Head to Block	15-3
Tappet Clearance	15-4
Valve Springs	15-4
Ignition	15-4
Timing	15-4
Carburetion	15-4
Preventive Maintenance Summary	15-5
Troubleshooting Valves	15-5
Disassembly	15-6
L-Head Valve Train	15-6
Overhead Valve Train	15-7
Inspection	15-7
Repair	15-8
Valve Guide Removal	15-8
Valve Guide Installation	15-9
Valve Seat Insert Removal and Installation	15-10
Valve Seat Installation	15-10
Cylinder Head Gasket Sealant	15-13
Application	15-13
Valve and Head Installation	15-13
L-Head Valve Adjustment	15-13
Overhead Valve Adjustment	15-14
Decompression Release	15-14
Valve Cooling	15-15
Intake Manifold and Valve Ports	15-16
Valve Lift and Timing	15-16
Intake Valves	15-16
Exhaust Valves	15-16
Valve Cam Lobes	15-17
Flywheel Function	15-17
Engine Vibration and Balance	15-17

GENERAL

This section contains service information concerning cylinder heads and valves. For critical dimensions, clearances and compression levels pertaining to particular model engines see the *SPECIFICATIONS* section of this manual.

GENERAL INFORMATION

The following text and associated illustrations apply to all Onan gasoline engines and diesels where applicable.

CARBON

Carbon, a by-product of combustion, is an enemy to efficient performance. Carbon prevents heat dissipation. Clean metal is a good heat conductor but carbon insulates and retains heat. This unduly increases combustion chamber temperatures and encourages warping and burning.

Unburned carbon residue gums valve stems and causes them to stick in the guide. Deposits of hard carbon with sharp points projecting become white hot and cause preignition and "pinging".

Carbon fouls spark plugs, resulting in engine miss and wasted fuel. Valves and seats are pitted and burned when held open by carbon particles. Carbon formation cannot be entirely eliminated but is minimized by high quality unleaded fuel and valve tuneups.

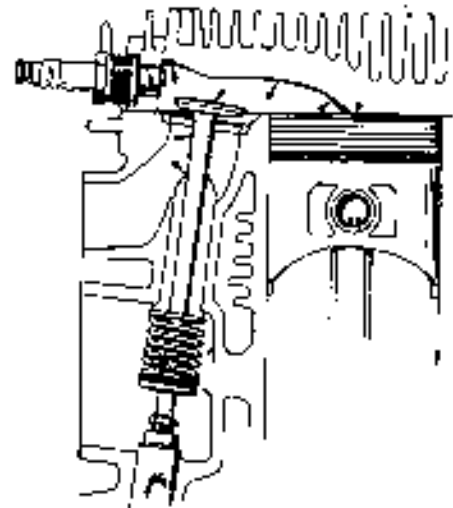

CORROSION AND WEAR

Warping, burning, pitting and out-of-round wear attack the exhaust valve. It is exposed to the high temperatures of exhaust gases. The intake valve's job is relatively light.

Burning and pitting are caused by the valve failing to seat tightly, permitting exhaust blowby. This condition is often traced to hard carbon particles on the seat. It may also be due to weak valve springs, insufficient tappet clearance, warpage and misalignment.

Warping occurs chiefly in the upper stem due to its exposure to intense heat. Out-of-round wear follows when the seat is pounded by a valve whose head is not in line with the stem and guide.

Oil and air are sucked past worn intake valve stems and guides into the combustion chamber, causing excessive oil consumption, forming carbon, and diluting carbonized fuel.

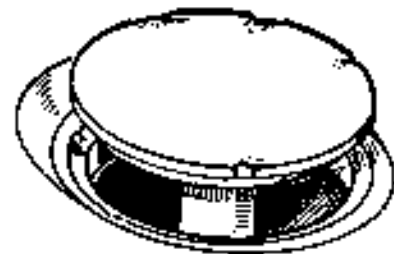

VALVE HEAD MARGIN

Scrap and replace any valve that cannot be entirely refaced with definite margin maintained. The amount of grinding necessary to true a valve face is an indication of the head warpage from axis or centering of its stem. With excessive warpage, a knife edge will be ground on part or all of valve head due to the considerable amount of metal that must be removed to completely reface. Heavy valve heads are required for strength and to dissipate heat. Knife edges lead to breakage and burning, and to preignition due to heat localizing on edge.

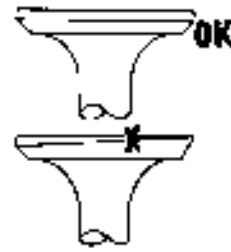

MISALIGNMENT

Misalignment is a product of wear, warpage and distortion. Wear, perhaps hastened by insufficient or improper lubrication, will eventually create sloppy clearances and consequent misalignment.

Warpage of the entire engine block is not uncommon, usually due to excessive heat caused by a clogged cooling system. More frequently the valve guide warps because of the variation in temperature over its length. The top of the guide is near combustion-chamber heat, while the bottom of the guide is cooled by water jackets.

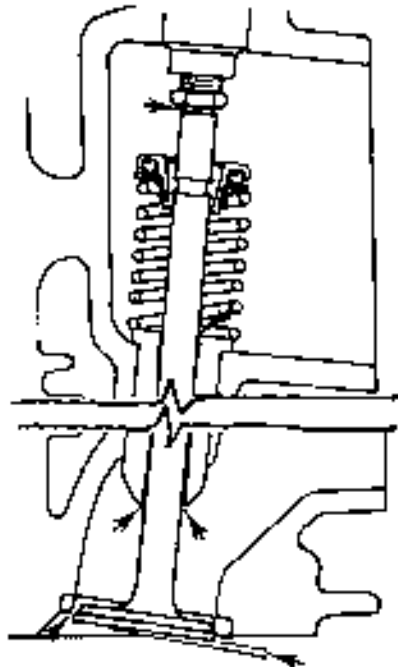

Distortion, caused by unequal tightening of cylinder-head bolts, often upsets alignments and clearances.

Any wear, warpage or distortion affecting the valve guide, destroys its function as an accurate bearing to keep the valve head concentric with its seat, and prevents leak-proof seating.

WIDTH OF SEAT

The tendency is usually to grind seats too wide when reconditioning. The seat width in many engines should be less than 1/8 inch (3.18 mm). Always have seat narrower than valve face. Follow engine manufacturer's recommendations in this as in all other technical matters. If necessary to narrow seat, use 15° stone. Seats too narrow prevent valve head from rapidly dissipating its heat to block. If new insert seat is installed, regrind to make concentric with the guide.



LOCATING VALVE CONTACT AREA

Maximum valve life is greatly dependent upon proper location of the area of contact between the valve and valve seat. Top figure shows correct position. Contact area can be located by using dividers across outer edge of seat to determine diameter. Then, using a flat grinding stone, remove metal at top of seat until correct diameter is obtained. Dress upper line of valve and valve seat contact area to a sharp edge at top of seat. Check concentricity of ground surface after grinding operation.

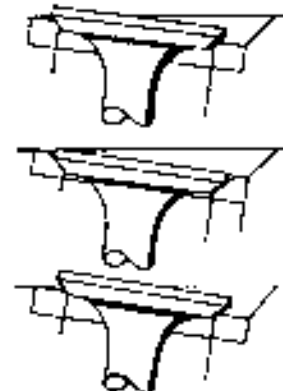

INTERFERENCE ANGLE

The interference angle method of reconditioning is advantageous where face deposits have been troublesome and where both the valve and seat are made of relatively hard materials. With this method, different seat and face angles are used and line contact between the valve face and seat occurs. In general, the position of the seat contact on the valve face should be approximately 1/16 inch (1.59 mm) below the upper edge of the valve face.



STEMS AND GUIDES

Always check valve stems and guides for wear. Use a Hole Gauge if available. Follow engine manufacturer's directions for replacement of valves and guides which are worn extensively. Too much clearance in the intake guide admits air and oil into combustion chamber, upsetting carburetion, increasing oil consumption, and making heavy carbon deposits. Sloppy exhaust guide clearance causes misalignment and bad seating, resulting in fast valve and seat wear. When clearance with stem exceeds original clearance by .002 inch (0.05 mm), generally speaking, replace either valve or guide or both, as may be necessary. Always regrind seat to make concentric with the newly installed guide.

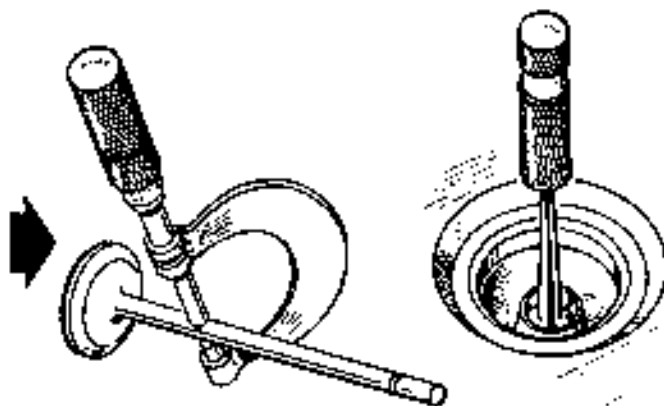

GASKETS

Gaskets make a seal between two metal surfaces, compensating for any slight difference that may exist between the surface of each part. To be effective, gaskets must be leakproof against air, water, oil and fuel. Gaskets used on head and manifold must also resist extreme heat and pressure. Assemble valve reconditioning job with new gaskets and install carefully according to instructions. Lost compression and resulting troubles are frequently traceable to leaking gaskets.

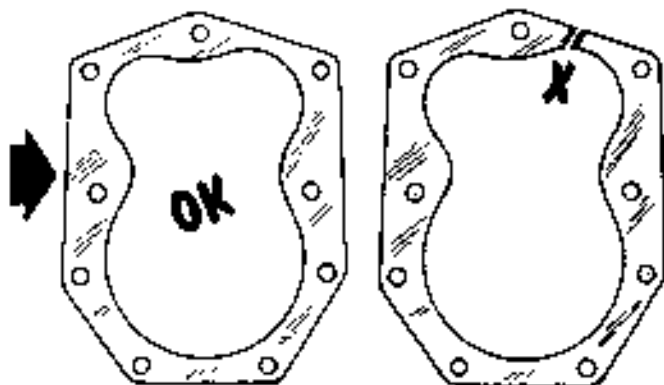

BOLTING HEAD TO BLOCK

Use torque wrench to uniformly tighten cylinder head studs to a predetermined tension. It is dangerous guesswork to depend on the "feel" of an ordinary wrench. The tightening of any one stud nut by less than one half turn will distort the head and block to a measurable degree. This distortion will seriously affect alignments and clearances, resulting in lost compression and fast wear, with oil and fuel wasted. Engine or tension wrench manufacturers will furnish recommended order or sequence for tightening down cylinder head studs, with amount of tension to be used.

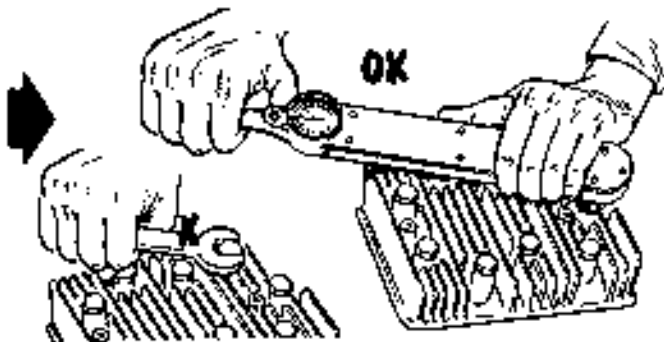

TAPPET CLEARANCE

Some of today's engines have hydraulic valve lifters for tappets which do not require adjustment. Others have tappets which should be adjusted according to engine manufacturers specifications. On this latter type of tappet, the correct clearance contributes to quiet engine operation and long valve and seat wear. Insufficient clearance causes the valve to ride open resulting in lost compression and burning. Too much clearance upsets timing and shortens valve life above its seat, preventing maximum intake and exhaust. Also check clearance between tappet and guide. Replace if clearance exceeds .006 inch (0.15 mm). Sloppy fit between tappet and guide permits tappet to strike valve stem end off center, causing side thrust on valve stem with excessive wear and bad seating.

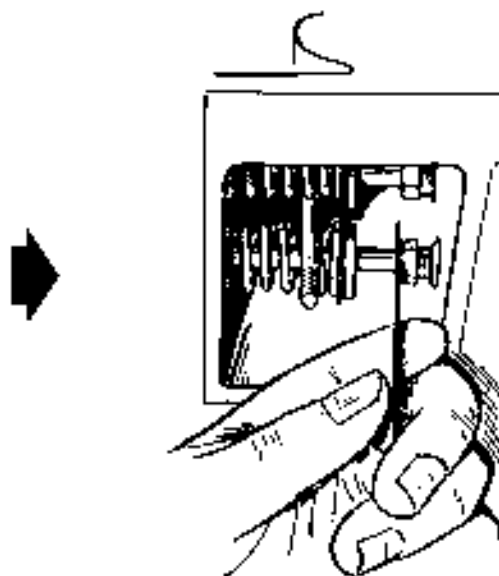

VALVE SPRINGS

Test valve springs for uniform strength. Use regular valve spring tester for accurate check — or place springs on end on a level surface (see that spring ends are flat) and use any straight edge to determine irregularity in height. Unequal or cocked valve springs will undo in the assembled job all the precision that has been put into it. Spring tension too weak allows valves to flutter. Spring tension too heavy causes "stretched" valves. Either condition aggravates wear on valve and seat with possible valve breakage.

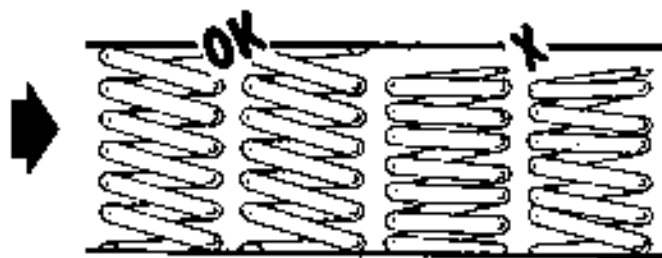

IGNITION

As part of every valve job, inspect and test spark plug electrodes and insulation. Clean electrodes and adjust gap with gauge according to manufacturer's specifications. A good spark is necessary for complete combustion. Check the ignition system (coils, distributor, generator, wiring, etc.) upon which the spark depends.

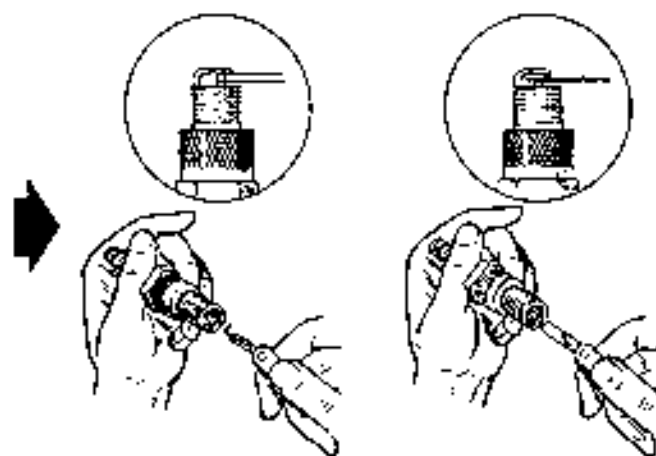

TIMING

Adjust ignition timing with close and careful accuracy. Incorrect timing will cancel all benefit of precision reconditioning. The initial or basic setting determines the relative advance of the automatic control at all speeds. If high octane fuel is used, spark timing may be set for peak performance.

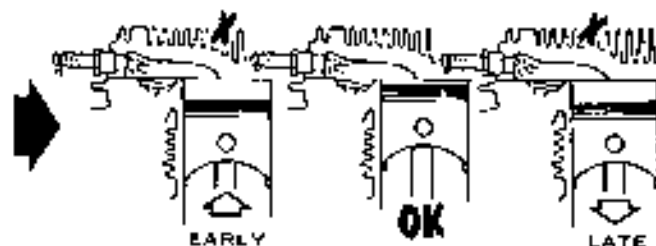

CARBURETION

Wash air cleaner thoroughly. Clean carburetor carefully and adjust air-fuel ratio according to manufacturer's instructions. The air-fuel mixture is governed by such factors as engine design, type and severity of service, and average load speed. Mixtures too rich waste fuel, foul spark plugs, form excessive carbon deposits, dilute lubrication and cause "lipping" at low speeds. Mixtures too lean raise combustion chamber temperatures and shorten life of valves, seats and spark plugs.

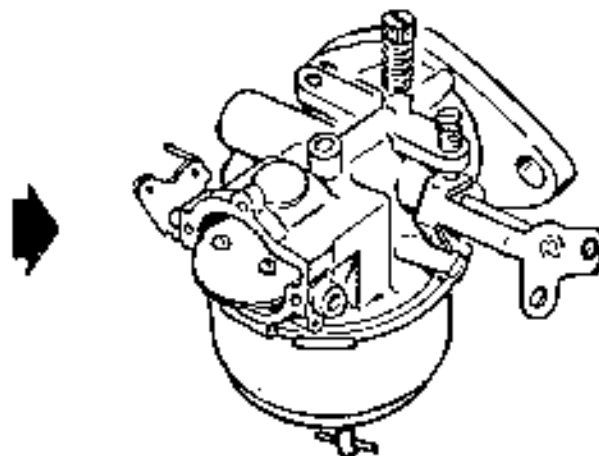

PREVENTIVE MAINTENANCE SUMMARY

The life expectancy of an engine depends on many things, the most important of which is regular maintenance. No two engines of uniform horsepower wear alike even under similar conditions. In addition to the general servicing procedures, the following factors can extend an engine's life with less operating expense, improved running conditions, and increased availability for work.

- Keep dirt out; it causes most of the wear in an engine.
- All bearing surfaces require lubricating oil to: (1) reduce friction, (2) lubricate and cool pistons, cylinders and bearings, (3) complete the seal between rings and pistons and cylinders, and (4) scavenge the engine of dirt and other wear particles by circulation into the filter.
- Regulate the right quantity of fuel to combustion chamber at right time and in condition to burn readily and completely with an unrestricted supply of air.
- Maintain clean engine cooling system to keep temperatures within specifications — 160° to 190° F (70° to 90° C).
- Prevent rust, scale, and corrosion by using approved coolants in water-cooled engines.
- See that engine breathes free y without intake or exhaust leaks or restrictions; valves, pistons, and rings must seal properly.
- Check for external oil leaks; tighten capscrews, fittings, and connections, and replace gaskets as required.
- Do not operate engine beyond maximum rated speed; overspeeding may damage pistons, valves, valve seats, cam lobes, or cause injection problems.
- Check oil level and pressure; low oil pressure indicates a faulty gauge, diluted lube oil, worn bearings, bearing failure, or a sticking pressure relief valve

- Regular checks by the operator and service personnel can detect signs of trouble before failure of one part leads to the ruin of other good parts.
- Preventive maintenance amounts to checks, adjustments, service, and minor repairs that extend the engine's life.
- Set up and follow a well-planned schedule. Use check lists to reduce service time and to be sure nothing is overlooked.

TROUBLESHOOTING VALVES

The cylinder compression test is the best way to determine the condition of valves.

NB engine uses a camshaft decompression device. When checking this engine for compression pressure, increase exhaust valve clearance to .020 (0.51 mm), then readjust after testing is complete.

An internal combustion engine has a certain nominal compression pressure which should be relatively the same in all cylinders. Variation between cylinders is due to deposit buildup, fits and clearances, valve lash, etc. Acceptable variations are usually considered to be 15 to 20 psi (104 to 138 kPa) between cylinders.

Refer to *Tools, Section 19* for compression tester offered in the Onan Tool catalog for diesel engines. Other compression testers are more common.

Testing Compression

The compression tester is used to determine the condition of valves, pistons, piston rings and cylinders.

To check compression:

1. Run the engine until thoroughly warm.
2. Stop engine and remove all injection nozzles or spark plugs.

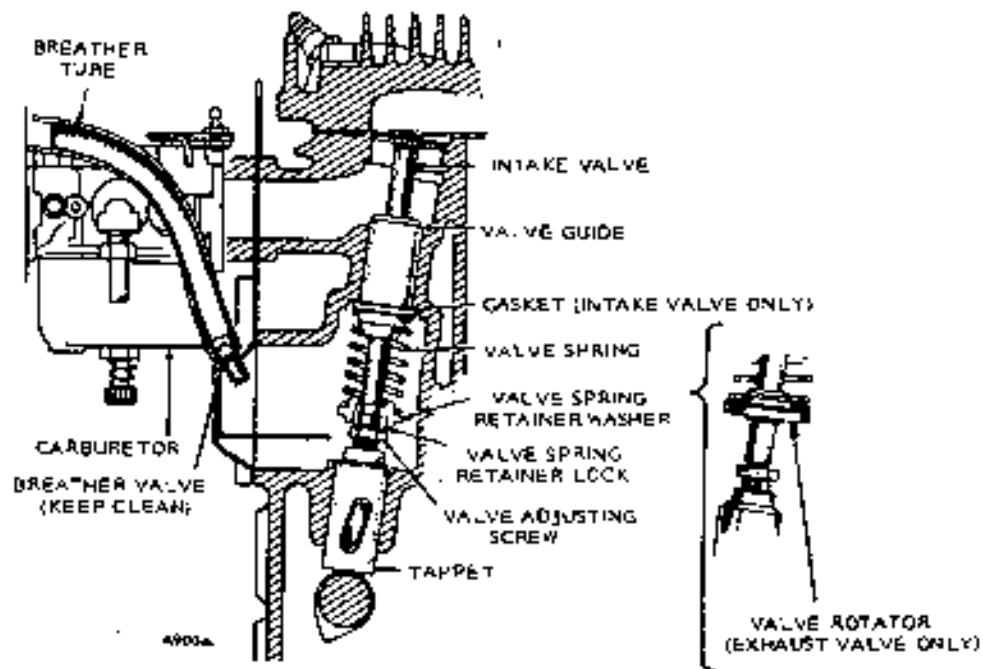

FIGURE 15-1. VALVE ASSEMBLY — ALL SINGLE CYLINDER ENGINES

NOTE: USE A STANDARD AUTOMOTIVE-TYPE WRENCH TO ADJUST THE TAPPETS.

NOTE: SEE VALVE TAPPET CLEARANCES IN TEXT.

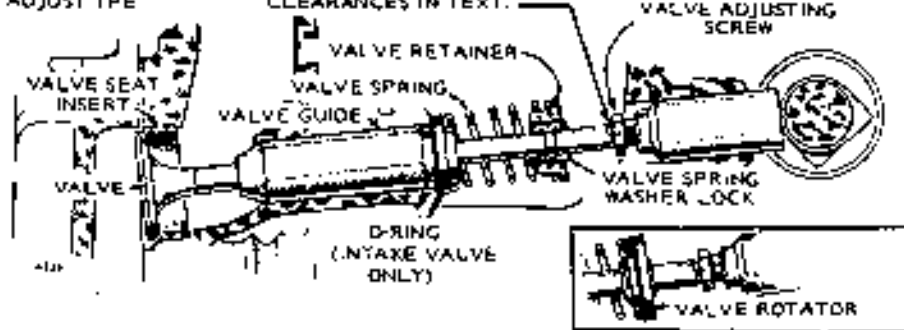

FIGURE 15-2. VALVE ASSEMBLY — ALL TWO-CYLINDER OPPOSED-PISTON ENGINES

3. Insert the compression gauge in one nozzle or spark plug hole.
4. Crank the engine and note the reading.
5. Squirt a small amount of SAE 30 oil into the cylinder and repeat the check.

CAUTION High compression diesel engines have very close clearances. Too much oil squirted in the cylinder may cause a hydrostatic lock and damage the piston when the engine is cranked with the compression tester installed.

- a. If cylinder pressure increases considerably, the rings are probably worn.
- b. If the pressure increases slightly, the valves are probably worn.

Refer to *Dimensions and Clearances, Section 4* of this manual. Tables 4-1 and 4-2 list compression pressures for Onan engines. There may be variations

due to temperature, atmospheric conditions and altitude. These pressures are for a warm engine at cranking speed (about 300 rpm).

DISASSEMBLY

Valves, tappets, rocker arms and push rods must be kept in order when removed from the cylinder head and then returned to their original location during reassembly.

L-head Valve Train (Figure 15-1 and 15-2):

1. Remove valve cover plate. Remove breather tube, baffle and filter.
2. Remove capscrews holding each cylinder head to cylinder block.
3. Remove each head. If it sticks, rap it sharply with a soft hammer. Don't use a pry.
4. Using a valve spring compressor, disassemble the valve spring assemblies, Figure 15-3.

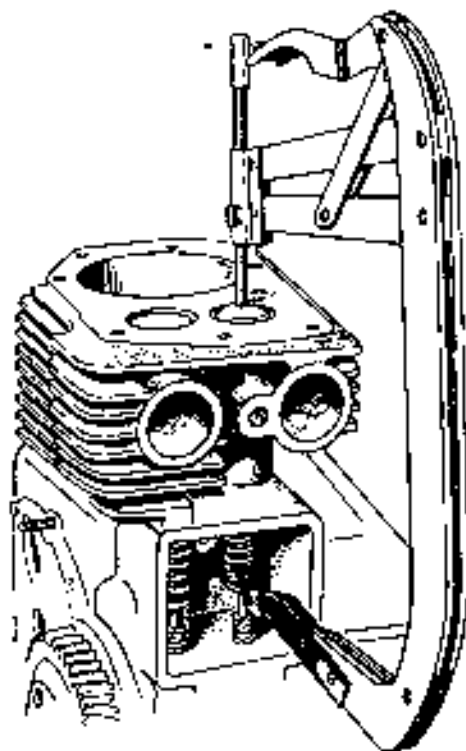

FIGURE 15-3 VALVE SPRING COMPRESSOR

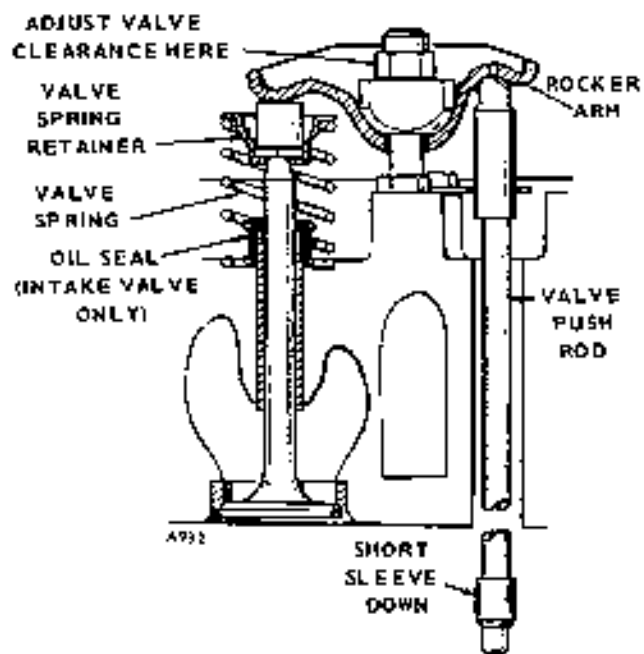

FIGURE 15-4. VALVE ASSEMBLY

Overhead Valve Train (Figure 15-4):

1. Remove rocker box cover, spark plugs and connecting oil lines to cylinder heads. Remove intake and exhaust manifolds.
2. Remove capscrews holding each cylinder head to cylinder block.
3. Remove each head. If it sticks, rap it sharply with a soft hammer. Don't use a pry.
4. Remove rocker arms and pushrods.
5. Use a valve spring compressor to disassemble valve spring assemblies.

INSPECTION

1. Use a petroleum solvent to clean carbon and any gasket material from all surfaces. If necessary, use a metal scraper.
2. Inspect cylinder head gasket surfaces for cracks, nicks or burrs.
3. Replace head if it is cracked.
4. Remove all burrs and nicks with an oil stone.
5. With a straight edge and thickness gauge, check the flatness of the cylinder head, Figure 15-5. The

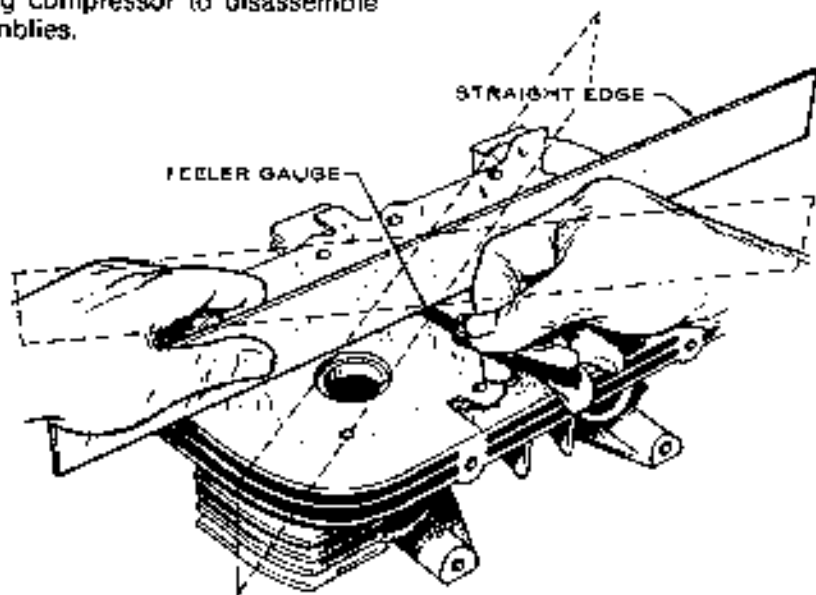

FIGURE 15-5. CHECKING CYLINDER HEAD FLATNESS

specification for flatness is a maximum of .003 inch (0.08 mm) over the complete length of cylinder head.

6. Inspect valve seat inserts for cracks, looseness or excessive wear. Replace the inserts if any of these conditions exist.
7. Replace if the width exceeds specifications or if they are pitted.
8. Check valve guide to valve stem clearance, Figure 15-5.

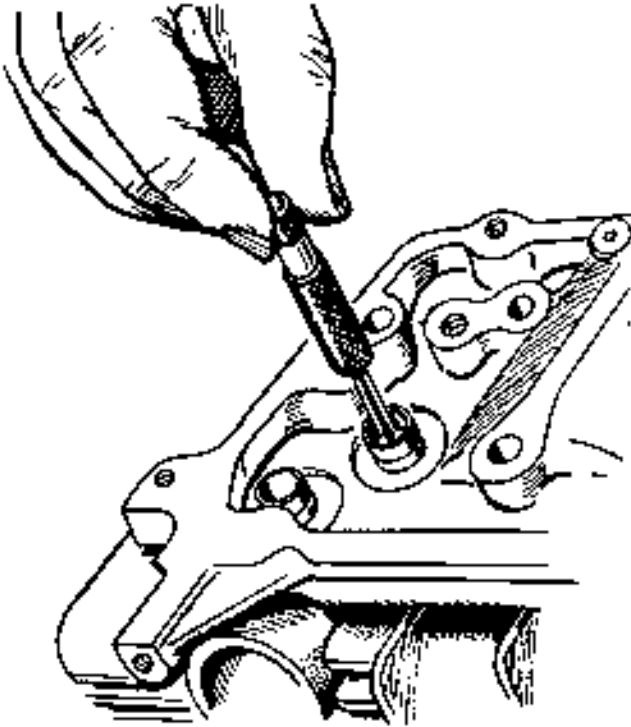

FIGURE 15-5. MEASURING VALVE GUIDE INNER DIAMETER

If the proper clearance cannot be obtained by replacing the valves, replace the valve guides.

9. Every valve must have a minimum of 1/32 inch (0.79 mm) margin, Figure 15-7. If the valve has less margin than this, it will heat up excessively. It very likely will retain that heat during the compression stroke and preignite the mixture, causing loss of power and economy. This valve is also susceptible to warping and breakage.

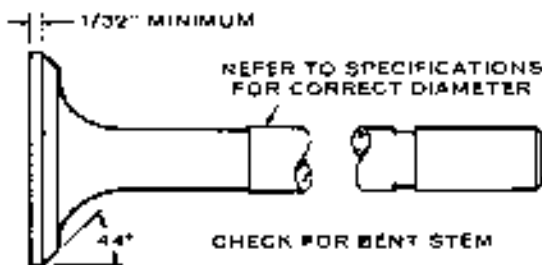

FIGURE 15-7. VALVE MARGIN

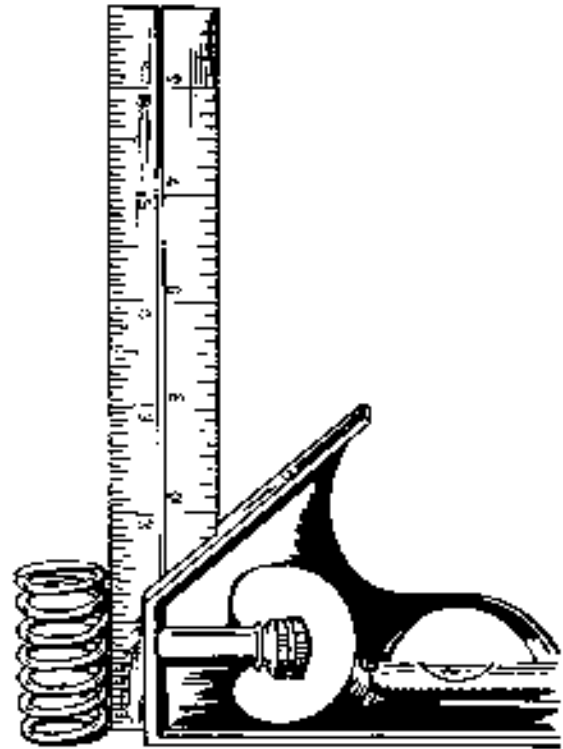

FIGURE 15-8. CHECKING VALVE SPRING SQUARENESS

Not all valves can be reconditioned. A badly warped valve must often be replaced because the excessive grinding required to make it seat correctly removes the margin. To make a valve gas tight, every trace of pitting must be removed from the valve face and seat. Deeply pitted or cul valves must sometimes be replaced because the grinding removes the margin.

10. Discard valve springs that show evidence of rust. Check each spring for squareness as shown in Figure 15-8.

Discard valve springs that are not within 1/16 inch of being square. Check the spring tension of each spring. If the spring pressure is seven or more pounds below specifications, replace the spring.

11. If the pad at the valve end of the rocker arm has a grooved radius, replace the rocker arm. Do not attempt to true this surface by grinding. Inspect the rocker arm for excessive wear at the fulcrum seat and the push rod seat. Check the rocker arm stud for looseness or stripped threads.

REPAIR

Valve Guide Removal

1. Before removing valve guides, use an electric drill with a wire brush to remove carbon and other foreign material from top surface of guides. Failure to perform this operation may result in damage to the guide bores.

REV. 9-76

- Use a guide driver to remove the old guides, on J-series engines. Figure 15-9. On L-head engines, drive the guides out with a hammer and punch. On J-series engines; use a press to remove the guides.

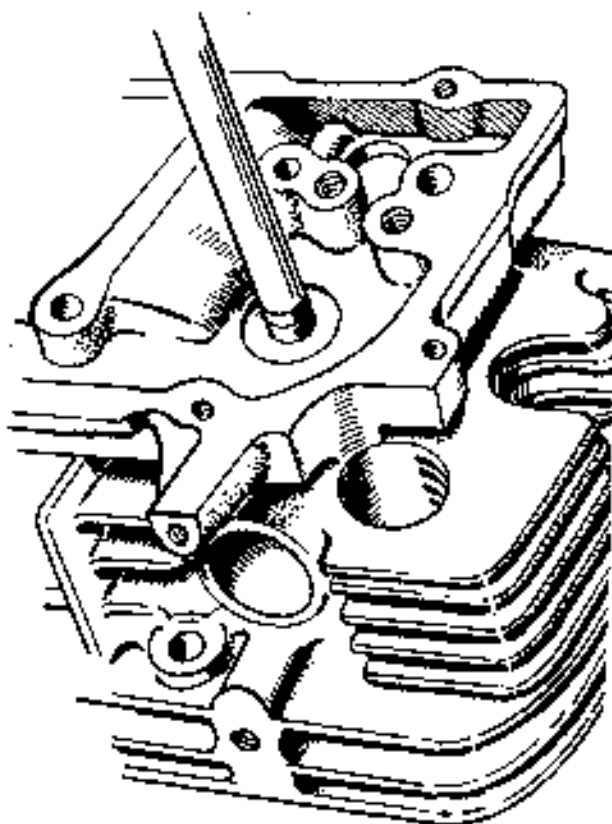

FIGURE 15-9. VALVE GUIDE REMOVAL

Valve Guide Installation

- A gasket must be used on the intake valve guide for the AJ, AK, LK and LKB engines. No gaskets are used on the CCK, CCKB, NH or the J-series engines.
- On L-head engines, place gasket (where required) on intake valve guide and install intake and exhaust valve guides from within valve chamber. On J-series, install guides in cylinder head. A suggested method of installation is illustrated in Figure 15-10.
- Run a small polishing rod with crocus cloth through valve guide holes to clean out carbon and other foreign materials.

Be careful not to enlarge the guide hole.

- Coat the outer edge of new guide with oil. Place guide, notch up, in cylinder head and press in until guide protrudes $11/32$ inch (8.73 mm) from rocker box side of head.

Be careful not to ream or hone the valve guides oversize or the engine will use an excessive amount of oil.

- Place proper valve guide reamer in a drill press (if not available, use an electric drill) to ream guides to proper size. Two different size reamers are used on the J-series

Intake guide — size .342" to .343"

Exhaust guide — size .344" to .345"

- Use polishing rod and crocus cloth to obtain a good smooth honed finish after reaming.
- Thoroughly wash cylinder head in solvent after reaming and honing is completed.

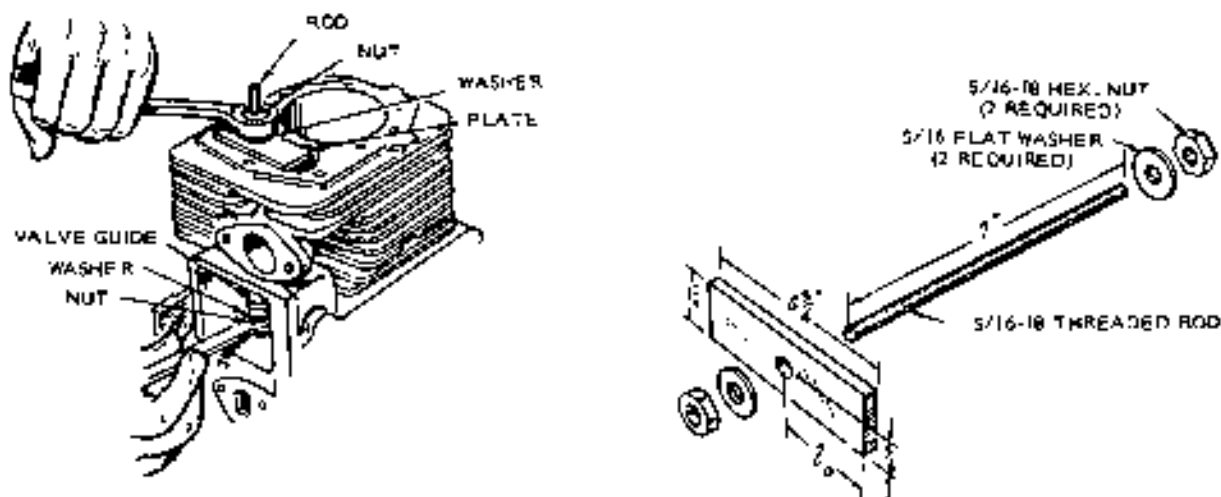
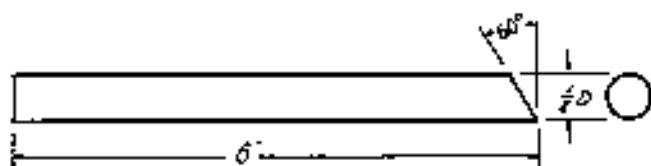

FIGURE 15-10. VALVE GUIDE INSTALLATION (L-HEAD)



VALVE SEAT REMOVAL TOOL

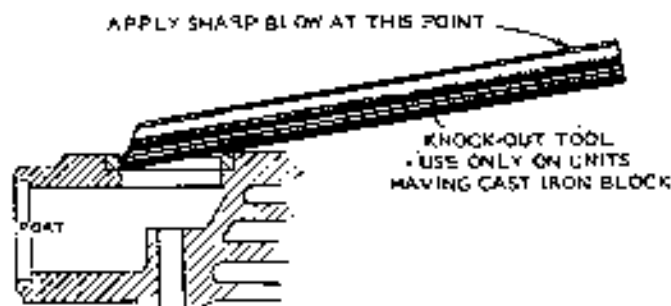

FIGURE 15-11. VALVE SEAT REMOVAL

Valve Seal Insert Removal

1. For engines with cast iron cylinder blocks (except J-series) use the knockout tool as shown in Figure 15-11. Insert tool under valve port side of the valve seat with the square end extending over the cylinder bore. With the sharp edge of the tool at the joint between the seat and its recess in the cylinder block, strike the end of the tool a sharp blow with a light hammer. This blow should crack the seat insert, after which it may be removed.

CAUTION Repeated blows may damage the surface of the counterbored recess.

2. A valve seat remover mounted in a drill press should be used to remove valve seats from J-series engines, Figure 15-12. Set the tool to cut 1/64 inch (0.40 mm) from the edge and bottom of the seat. The remaining rind is easy to remove.

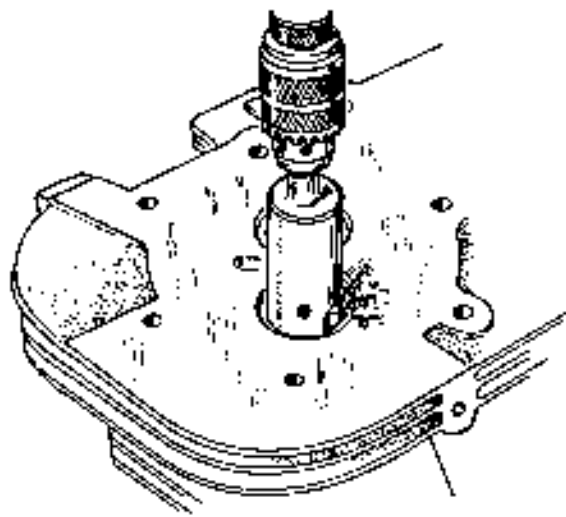

FIGURE 15-12. REMOVING VALVE SEATS - J-SERIES

3. For engines with aluminum cylinder blocks, use a standard 3/4 inch or 1 inch pipe tap depending on the seat diameter, Figure 15-13. Place a small piece of flat steel or a flat washer on the top of the valve guide for the tap to bottom against. Turn the pipe tap in until the seat starts to turn in the crankcase recess. Continue to turn the tap and pull outward to remove the seat. If the valve guide is pushed downward by the tap, be sure to push it back into the proper position. Because a slight amount of recess metal will be removed by this operation, an oversize replacement seat must be used.

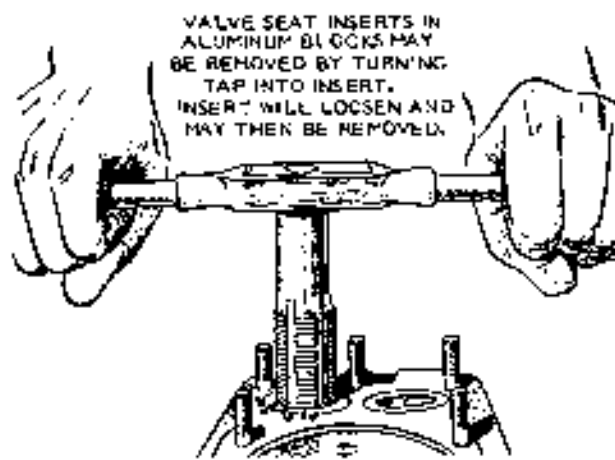

FIGURE 15-13. REMOVING VALVE SEAT FROM ALUMINUM BLOCKS

Valve Seat Installation

After the old seal has been removed, clean out any carbon or metal burrs from the seat insert recess.

1. The easiest and most accurate method of installation involves slowly heating the cylinder block to 325° F (163° C) and chilling the valve seat insert in dry ice for one-half hour. Use the proper driving tool and hammer to install the insert.

REV. B-76

2. Insert the pilot of the tool in the valve guide hole in the cylinder block and quickly drive the valve seat insert in so that the insert goes evenly to the bottom of the counterbored recess in the cylinder block.
3. Make certain that the valve seat insert rests solidly on the bottom of the recess all the way around its circumference, Figure 15-14. Refer to the Tools section for proper valve seat driver for each series of engines.

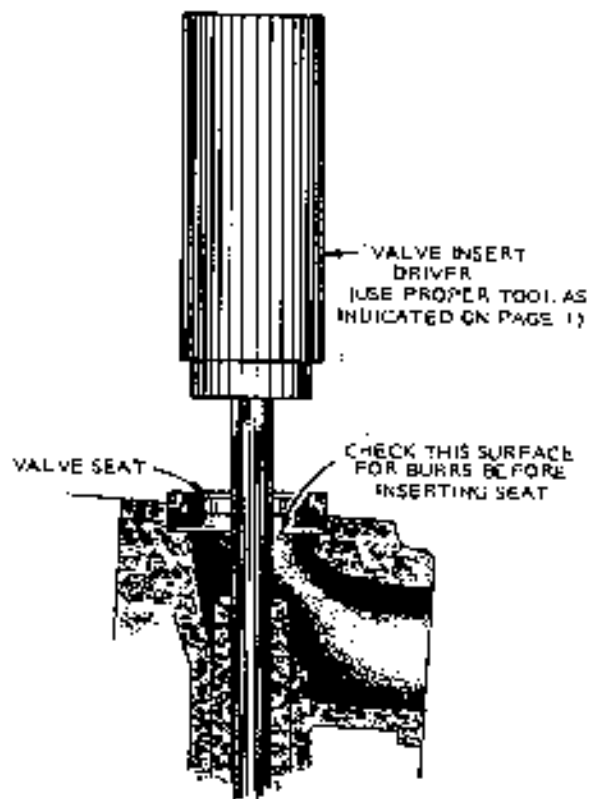

FIGURE 15-14. INSERTING NEW VALVE SEAT

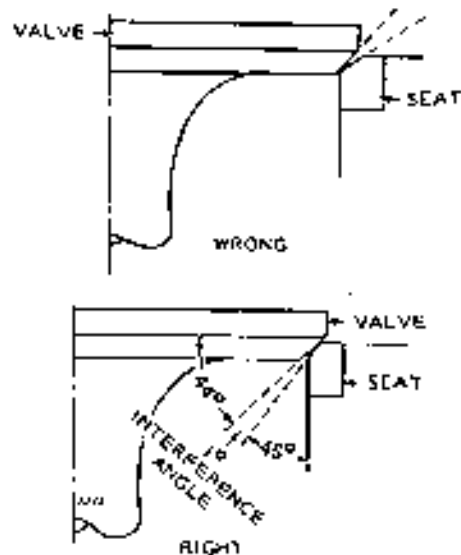
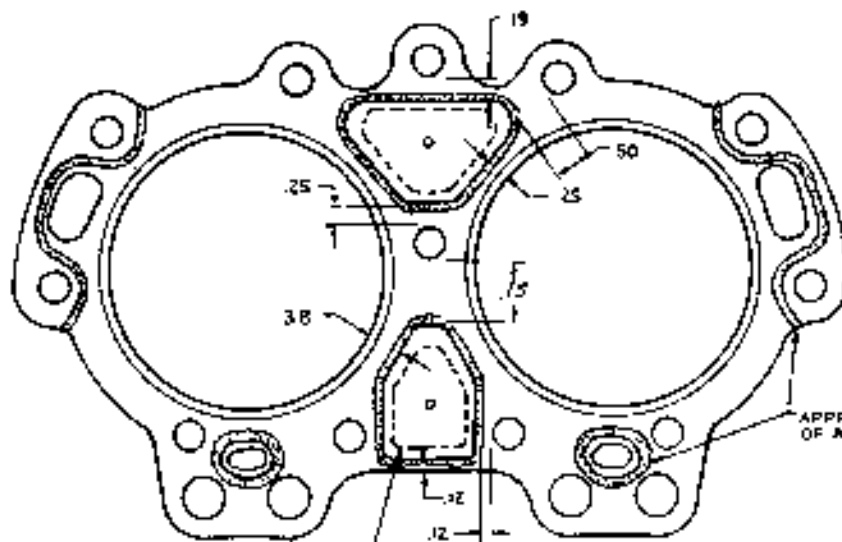

FIGURE 15-15. VALVE SEAT FACE

The valve FACE angle is 44° , Figure 15-15. The valve SEAT angle is 45° . This 1° interference angle results in a sharp seating surface between the valve and the top of the valve seat. The interference angle method of grinding valves minimizes face deposits and lengthens valve life.

Valves should not be hand lapped, if at all avoidable, since the sharp contact may be destroyed. This is especially important where stellite faced valves and seats are used. Valve faces should be finished in a machine to 44° . Valve seats should be ground with a 45° stone, and the width of the seating area should be $1/32$ to $3/64$ inch (0.79 to 1.19 mm) wide. Grind only enough to assure proper seating.



NOTE:

1. BEAD SHOULD BE .01-.06 THICK. BOTH SIDES OF GASKET. RTV APPLIED ON ONE SIDE MAY BE MADE ON FINISHED SURFACE OF BLOCK.
2. GASKET TO BE INSTALLED BEFORE RTV HARDENS.
3. MINIMUM CURE TIME BEFORE OPERATING ENGINE - 1 HR. (WATER AND WATER VAPOR WILL ACCELERATE CURING OF RTV RUBBERS).

FIGURE 15-16. HEAD GASKET — RTV SEALANT APPLICATION

REV. 9-76

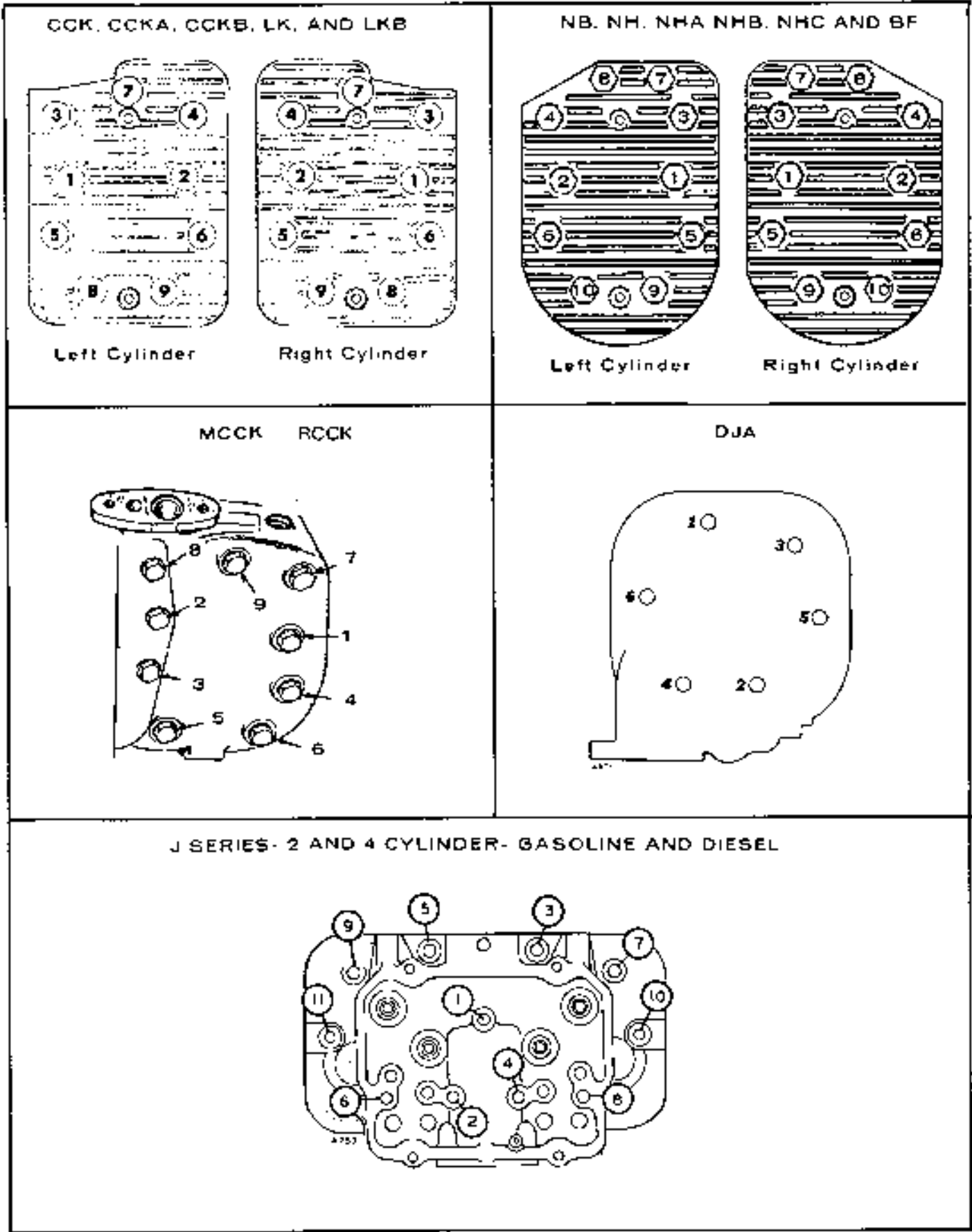

FIGURE 15-17. CYLINDER HEAD BOLT TORQUE SEQUENCE

REV. 9-76

CYLINDER HEAD GASKET SEALANT

The cylinder head gaskets on all 2 and 4 cylinder, water-cooled, diesel engines (DJ series industrial or generator sets) require a Room Temperature Vulcanizing (RTV) Sealant around the water passages between the gasket, head, and block whenever the head gaskets are replaced. The RTV sealant must be used along with each new head gasket.

Onan recommends the White RTV Sealants such as:

- Dow-Corning Sifastic RTV Silicone Rubber Adhesive #732
- General Electric White RTV Sealant

Application

Apply sealant bead .03-.06 inches thick at six places on both sides of the head gasket according to dimensions shown in Figure 15-16. The sealant may also be applied to the finished surface of the block and just one side of the gasket.

CAUTION The gasket must be installed before the RTV Sealant hardens (within one half hour). Do not use excessive sealant as it could squeeze into the cored holes or into the piston compression chamber and affect valve operation.

One hour is the minimum cure time before operating the engine. Water and water vapor accelerate the curing time of the RTV sealant so water or coolant can be added to the engine after the head bolts are torqued to specifications. Engine heat completes the curing process. Refer to Table 15-1 for additional gasket installation and torquing instructions and valve adjustments.

VALVE AND HEAD INSTALLATION— TWO CYLINDER OPPOSED ENGINES

1. Insert tappets in crankcase holes.
2. Install valves, springs and guides.
3. Check each valve for a tight seat; make pencil marks at intervals on the valve face and observe if the marks rub off uniformly when valve is rotated part of a turn in seat. If seat is not tight, regrind valves.
4. Using a valve spring compressor, compress each valve spring and insert the valve spring retainer and retainer locks.
5. Set valve clearance to specifications listed in Section 4.
6. Install heads and gaskets to cylinder block.
7. Tighten head bolts to correct torque following the sequence in the appropriate illustration, Figure 15-17. See Specifications, Section 4 for correct torque values.
8. Install exhaust manifold, oil lines, spark plugs and carburetor.
9. On water cooled units, install thermostat assembly and fill cooling system.

On an overhauled engine, retighten the cylinder head bolts and check valve clearance after the first two hours of operation.

J-SERIES VALVE AND HEAD INSTALLATION

1. Replace push rods and tubes in their proper locations. Be sure the bottom of each tube has a spring, two steel washers, and an O-ring and the top end has an O-ring.
2. Push a valve stem oil seal onto each intake valve guide and clamp in place. Then oil inside surface of each seal.

Diesel engines built before June, 1962 had no valve seals.

3. Oil stem of each valve lightly and insert each in its own guide.

Check each valve for a tight seal with an air pressure type tester. If a tester is not available, make pencil marks at intervals on the valve face and observe if the marks rub off uniformly when valve is rotated part of a turn in seat. If seat is not tight, regrind valves.

4. Using a valve spring compressor, compress each valve spring and insert the valve spring retainer and retainer locks.
5. Install head assembly and new gasket to cylinder block.

On four cylinder models, observe this special procedure to align the heads and prevent air leaks. Refer to Cylinder Head Gasket Sealant information.

- a. Assemble heads and gaskets to block and install the capscrews, but do not tighten.
- b. Install intake manifold to heads and tighten nuts to proper torque (four cylinder only).

Use Never-Seez, Fel-Pro C5-A or equivalent thread lubricant when installing cylinder head bolts. Apply on threads and between head of bolt and flatwasher.

6. Tighten cylinder head bolts finger-tight.

Installing manifold now aligns all four exhaust ports with the exhaust manifold before the heads are torqued down.

7. Tighten cylinder head bolts in sequence shown in Figure 15-17 to 25-30 ft. lbs. (34-41 N•m).
8. Tighten cylinder head bolts in same sequence to 44-46 ft. lbs. (60-62 N•m).
9. Retighten head bolts as in Step 8.

CAUTION Cylinder head bolts on DJ series water-cooled units that have been overhauled must be retorqued after 1/2 hours to 2 hours of operation. (Not necessary on new units from factory.)

Torque cylinder head bolts on air cooled diesel engines to 37-40 ft. lbs. (50-54 N•m).

10. Diesel engines: Install exhaust manifold, nozzles,

glow plugs and oil lines.

Gasoline engines: Install exhaust manifold, oil lines, spark plugs and carburetor.

11. Install valve stem caps.
12. Install push rods, rocker arms and rocker arm nuts.
13. Set valve clearance to Specifications listed in Section 4.
14. Install rocker box covers.
15. On water cooled units, install thermostat assembly and fill cooling system.

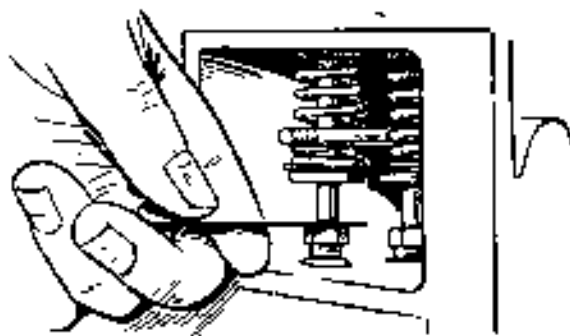

FIGURE 15-18. L-HEAD ADJUSTMENT

L-HEAD VALVE ADJUSTMENT

Tappet clearance (Figure 15-18) may be easily checked after removing the valve compartment cover and the blower housing.

1. Crank the engine by hand until the intake valve (the one nearest the carburetor) opens and closes.
2. Continue turning the flywheel slowly until the mark on the flywheel is in alignment with the "TC" mark on the gear cover.
3. The correct tappet clearance for both the intake and exhaust valves appear in the Specifications Section 4.
4. Tappets are fitted with self locking adjusting screws. Use a 7/16 inch wrench for the screw, and a 9/16 inch wrench for the tappet when making any adjustment.

OVERHEAD VALVE ADJUSTMENT

The valves are adjusted cold. After the cooling period, adjust No. 1 cylinder first and the rest in the firing order.

To adjust valve clearance on each cylinder, proceed as follows:

1. Rotate flywheel clockwise until cylinder having its valves adjusted is up on a compression stroke and the TC mark on the flywheel lines up with the timing pointer on the gear cover, then turn 10-45 degrees past TC to be sure lifter moves off ramp of cam.

In this position, both valves will be closed and the rocker arms are free to move slightly indicating maximum clearance.

2. Using a feeler gauge, check clearance between rocker arm and valve. See Figure 15-19.
3. Increase or reduce clearance until proper gap is established. Adjust with lock nut which secures rocker arm to cylinder head. Refer to Specifications, Section 4 for correct valve clearance for your particular engine.

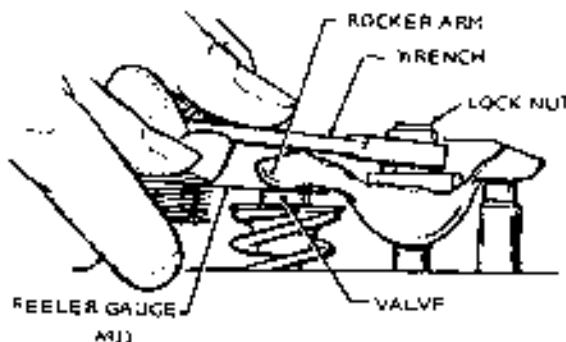

FIGURE 15-19. VALVE ADJUSTMENT

DECOMPRESSION RELEASE

The decompression release mechanism (Figure 15-20) holds the exhaust valve open long enough for cranking speed (rpm's) to build up without opposition from compression. The release solenoid energizes when starting speed is attained to release the exhaust valve for operation as long as the engine runs. The solenoid deenergizes when the engine is shut down allowing the release mechanism to open the exhaust valve and stop the engine by decompression.

1. Before adjusting the decompression mechanism, the valves must be set for the correct clearance.
2. With piston 10 degrees to 45 degrees past TDC on power stroke, hold arm in decompression position (tension against spring). Turn set screw so it just touches exhaust rocker arm. The release arm must be tight against snap ring during adjustment. Then turn screw exactly one revolution clockwise. Original factory setting is marked with white or yellow paint.

CAUTION

If screw is tightened more than one turn, piston could hit exhaust valve.

3. Hold the set screw and lock it into position with the attached nut. Turn the nut hand tight plus 1/4 to 1/2 turn to lock the mechanism.
4. When reassembling the rocker cover, remove the solenoid, dip the plunger "O" ring in oil and reinstall when cover is on the engine. Align solenoid so terminal "SW" is above terminal "IGN."

REV. 10-76

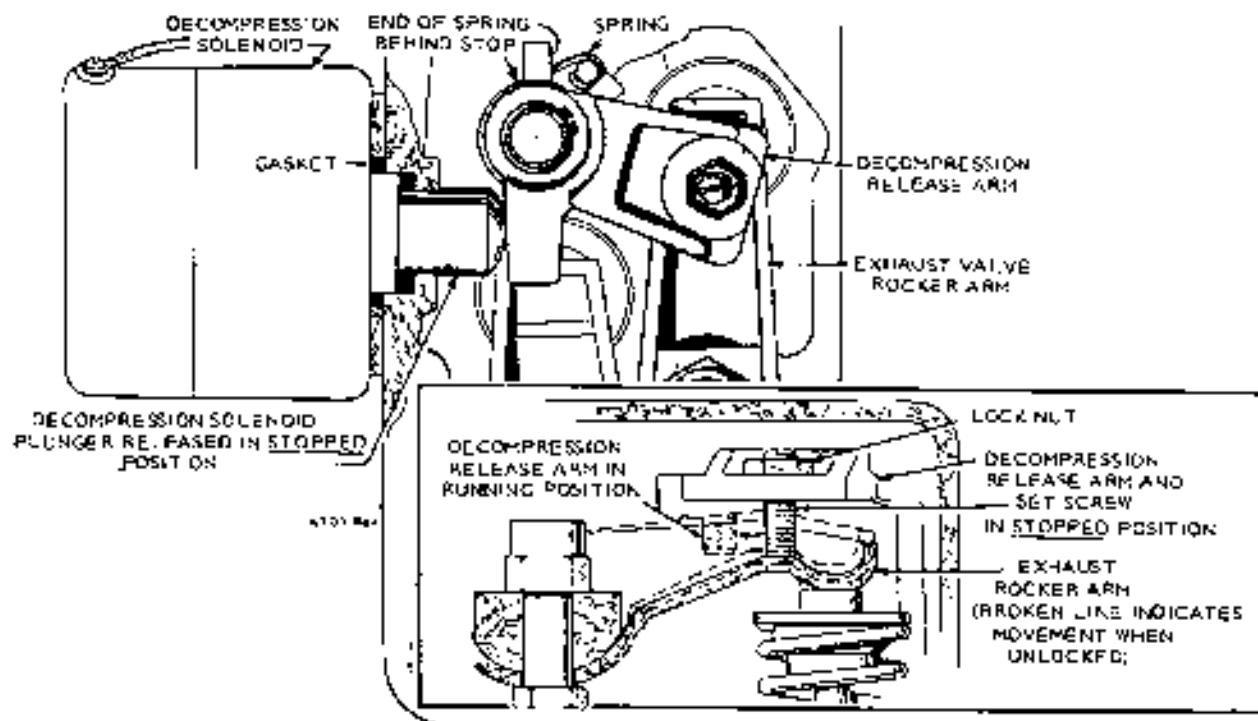

FIGURE 15-20. DECOMPRESSION MECHANISM

VALVE COOLING

Valve cooling is a critical part of engine performance. The exhaust valve transfers its heat through the stem to the guide which in turn conducts the heat to the cylinder head. Figure 15-21. Heat is also transferred from the valve seat to the head. Providing adequate cooling air or cooling water to the valve area is of prime importance because the cylinder head contains most of the combustion chamber. It becomes hot on the power stroke and must be cooled quickly and uniformly to retain its physical strength and shape and to prevent hot spots from developing in the combustion chamber causing pre-ignition.

The piston is cooled, to some extent, by oil splashing against the underside of it. The piston rings transmit heat from the piston to the cylinder walls. This heat plus the heat from the combustion flame must be dissipated to the atmosphere by the cooling fins on an air-cooled engine or by circulating water on water-cooled engines.

If engine cooling is inadequate, the oil temperature runs too high and the oil breaks down causing excessive carbon and varnish buildup and sticking rings. The cooling air requirements of an air-cooled or water-cooled engine takes between 5- and 10-percent of the available engine power.

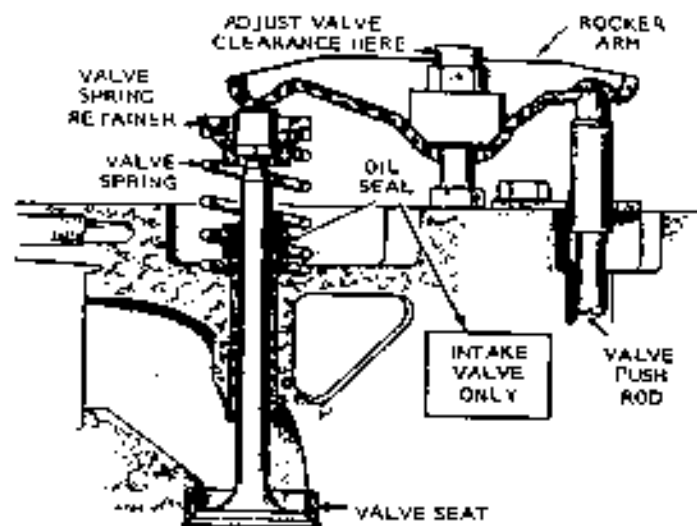

FIGURE 15-21. VALVE MECHANISM

INTAKE MANIFOLD AND VALVE PORTS

The intake manifold, valve ports and throat area of the pre-combustion and combustion chambers must be of such size and shape that air can flow through with minimum restriction. Accumulations of carbon or lead deposits in these areas will definitely decrease the engine's maximum power.

VALVE LIFT AND TIMING

Intake and exhaust valve timing and the amount of valve lift are extremely important to the four stroke cycle engines, Figure 15-22.

Intake Valves

An intake valve begins opening slightly before the piston reaches top center (TC) on the exhaust stroke. The intake valve must be open enough before the piston passes TC and starts downward to draw air unrestricted into the cylinder. It must then open fast and far enough to allow maximum airflow through the intake valve port at a rapid rate. Since air in motion has inertia, we keep the intake valve open as the piston moves beyond bottom center (BC). It remains open long enough to pack air into the cylinder until the pressure buildup tends to reverse air movement and then closes quickly. In high rpm engines, the closing point may be 35° to 65° of crank travel beyond BC.

Both valves, intake and exhaust, are closed during the compression stroke and during most of the power stroke.

Exhaust Valves

A cam begins opening the exhaust valve before bottom center is reached on the power stroke and allows it to close quickly before the intake valve opens near the end of the exhaust stroke, Figure 15-23. In this way, some of the energy from the expanding exhaust gases is sacrificed on the power stroke, but the exhaust valve remains open long enough to completely clear the cylinder of exhaust gases before the intake valve starts opening.

Ordinarily, the intake valve does not feel excessively high temperatures because it is cooled by the incoming fresh air; it is also closed all during the compression, power, and exhaust strokes. The exhaust valve, however, receives the full blast heat of the exhaust gases which can dissipate only through the open valve and its seat. At wide open throttle, the exhaust valve gets red hot. To withstand such temperatures, the valve head must be of stainless steel or it will corrode very rapidly. Therefore, the face of the valve is coated with chrome-cobalt to provide sufficient hardness and corrosion resistance.

IO - INTAKE OPENING - 19° BTC
TC - INTAKE CLOSING - 50° ABC
EC - EXHAUST OPENING - 50° BDC
EO - EXHAUST CLOSING - 15° ATC

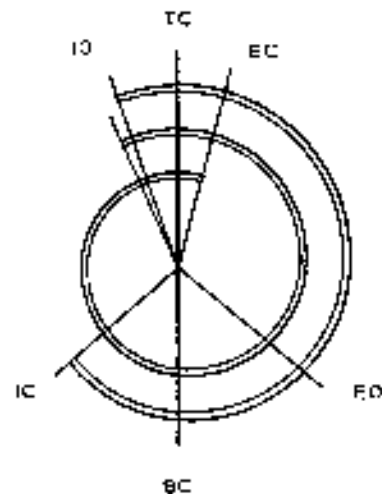

FIGURE 15-22. VALVE TIMING (J-SERIES)

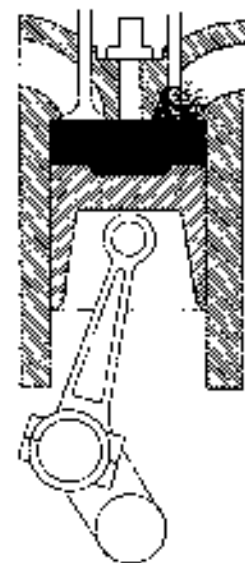

FIGURE 15-23. EXHAUST VALVE (DIESEL)

VALVE CAM LOBES

Valve cam lobes (Figure 15-24) are designed in an egg-shaped oval contour to provide:

- Clearance of a few thousandths of an inch during part of the cycle when the valves must be closed.
- A shape that causes valve rotation.
- A ramp for engaging the valve and starting its lift.
- A portion that accelerates the valve to maximum opening velocity.
- A section that decelerates the valve to a stop on the nose of the cam.
- The opposite half of the cam lobe that allows the valve to close by a similar sequence.

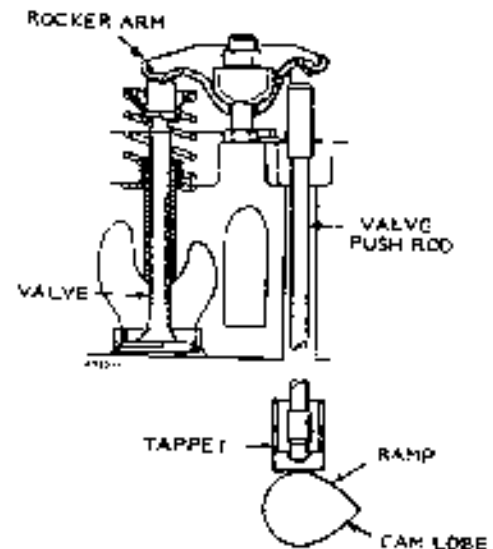

FIGURE 15-24. VALVE CAMMING

FLYWHEEL FUNCTION

An engine produces its power during the power stroke only. Therefore, the flywheel function is to provide each piston with sufficient momentum to carry it through the other three strokes without much loss of speed, Figure 15-25.

Flywheels are designed somewhat on the light side to reduce engine weight. The equipment being driven by the engine is depended on to assist flywheel action. At best, there is always some slowing down between power strokes and subsequent speeding up during the power strokes. This is called cyclic irregularity and it becomes important on certain applications where couplings, drive pulleys, or clutches are used.

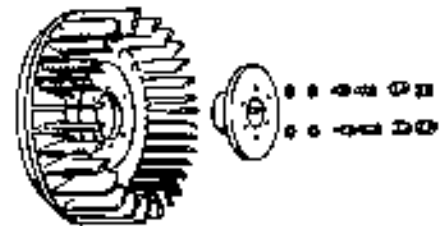

FIGURE 15-25. TYPICAL FLYWHEEL

ENGINE VIBRATION AND BALANCE

In a single cylinder engine, the reciprocating action of the piston and connecting rod causes a shaking action which must be balanced as well as possible. The reciprocating unbalance is counteracted by counterweighing the crankshaft with 59 percent to 75 percent of the weight of the piston and rod. The added weight is placed on the crankshaft opposite the crank throw, Figure 15-26. The balance of multi-cylinder engines is more complex, but the same principles apply.

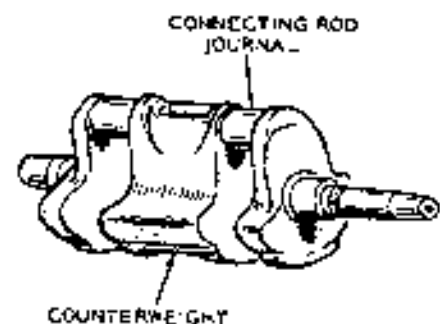

FIGURE 15-26. CRANKSHAFT BALANCE

SECTION 16.

PISTONS, RINGS, CONNECTING RODS, BEARINGS, AND CYLINDER BLOCK

INDEX

PISTONS AND CONNECTING RODS	16-1
Removal	16-1
Cleaning	16-1
Inspection	16-2
Repair	16-2
Assembly	16-4
Installation of Piston in Cylinder	16-5
CYLINDER BLOCK	16-6
Inspection	16-6
HONING PROCEDURE ..	16-7

PISTONS AND CONNECTING RODS

Removal

Observe the following procedure when removing pistons and connecting rods from the engine:

1. Remove cylinder head and oil base pan from engine.
2. Remove ridge from top of each cylinder with a ridge reamer before attempting piston removal, Figure 16-1. Forcing the piston from the cylinder before reaming may cause damage to the piston lands.

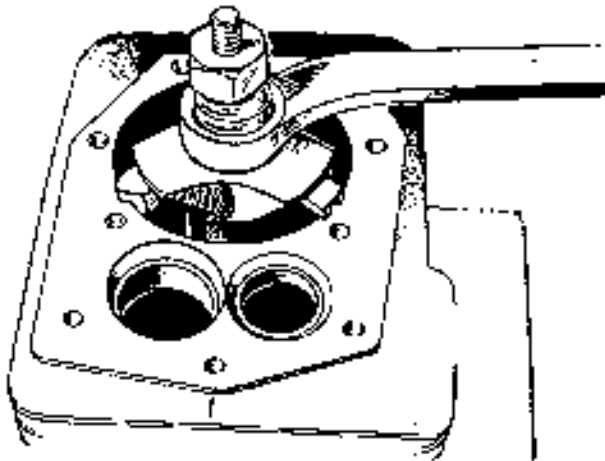

FIGURE 16-1. REMOVING RIDGE FROM CYLINDER

3. Turn crankshaft until piston is at bottom of its stroke and remove connecting rod bolts. Lift rod bearing cap from rod and push rod and piston assembly out through top of cylinder using a hammer handle. Avoid scratching crankpin and cylinder wall when removing piston and rod.

Mark each piston and rod assembly so they can be returned to their respective cylinders after overhaul. Keep connecting rod bearing caps and bearings with their respective rods.

4. Remove piston rings from piston with a piston ring spreader as shown in Figure 16-2. Remove piston pin retainer and push piston pin out.

Cleaning

1. Remove dirt and deposits from the piston surfaces with an approved cleaning solvent.
2. Clean the piston ring grooves with a groove cleaner or the end of a piston ring filed to a sharp point, Figure 16-3. Care must be taken not to remove metal from the groove sides.

Do not use a caustic cleaning solvent or wire brush for cleaning pistons.

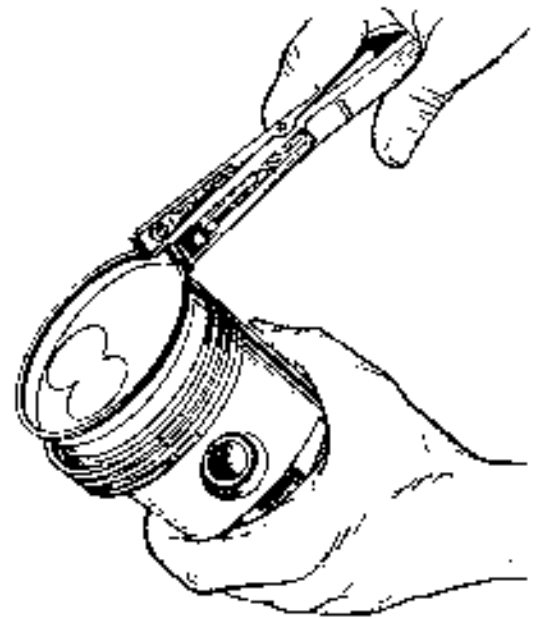

FIGURE 16-2. REMOVING PISTON RINGS

3. When cleaning connecting rods in solvent, clean the rod bore and back of the bearing inserts. Blow out all passages with compressed air.

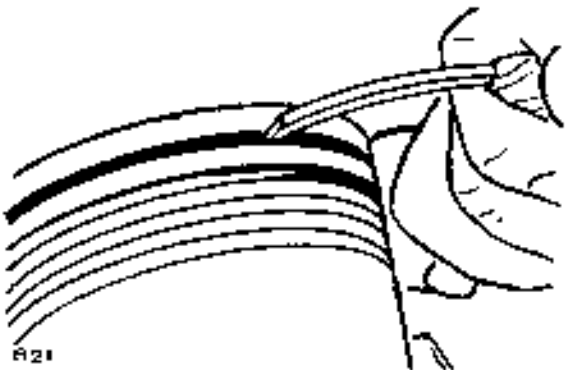
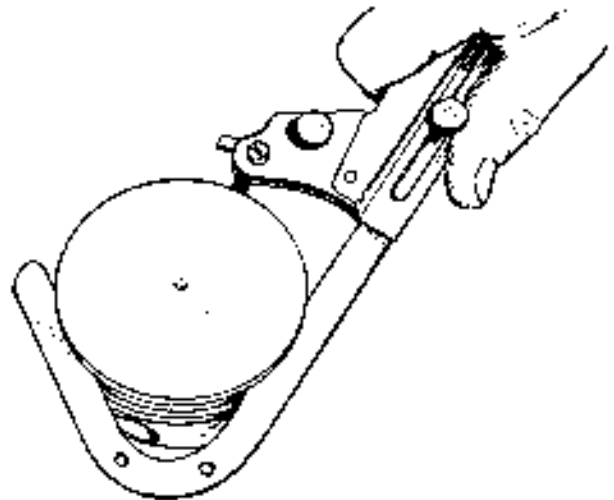

FIGURE 16-3. PISTON GROOVE CLEANING

Inspection

The following text contains inspection procedures concerning pistons, connecting rods and rod bearings.

1. Piston Inspection

- Inspect pistons for fractures at ring lands, skirts and pin bosses. Check for wear at ring lands using a new ring and feeler gauge as shown in Figure 16-4.

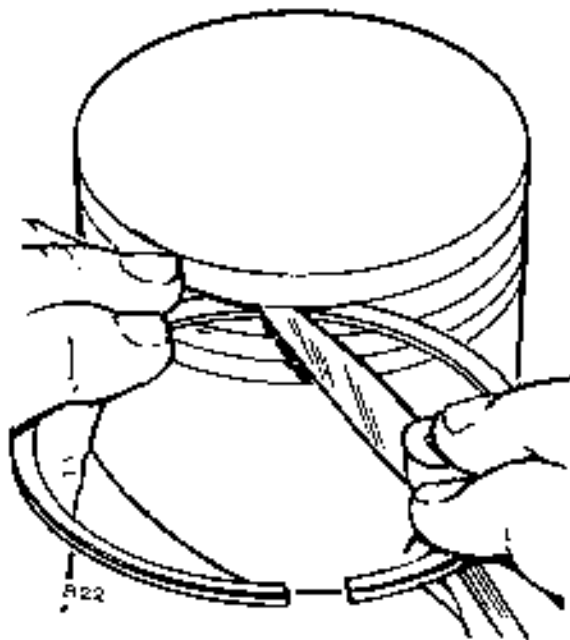

FIGURE 16-4. CHECKING RING SIDE CLEARANCE

- Replace the piston when the side clearance of the top compression ring reaches 0.008 inch (0.20 mm) for gas or gasoline engines and 0.006 inch (0.15 mm) for diesel engines.
 - Replace pistons showing signs of scuffing, scoring, worn ring lands, fractures or damage from preignition. Excessive piston wear near edge of top ring land indicates preignition.
- ### 2. Connecting Rod Inspection
- Replace connecting rod bolts or nuts with damaged threads. Replace connecting rods with deep nicks, signs of fractures, scored bores or bores out of round more than 0.002 inch (0.05 mm).
 - Use a new piston pin to check the pin bushing for wear. A push fit clearance is required and varies from engine to engine (see *TABLE OF CLEARANCES, Section 4*). If a new piston pin falls through a dry rod pin bore of its own weight, replace the bushing.
- ### 3. Connecting Rod Bearing Inspection
- Inspect bearings for burrs, breaks, pitting and

wear. Replace bearing inserts that are scored, have the overlay wiped out, show fatigue failure or are badly scratched.

- If bearings appear to be serviceable, check them for proper clearance. If they exceed the specified clearances listed in Section 4, Replace them.
- ### 4. Checking Bearing Clearance With Plastigauge
- Make certain that all parts are marked or identified so that they are reinstalled in their original positions.
 - Place a piece of correct size Plastigauge in the bearing cap the full width of the bearing insert about 1/4 inch off center (Figure 16-5).

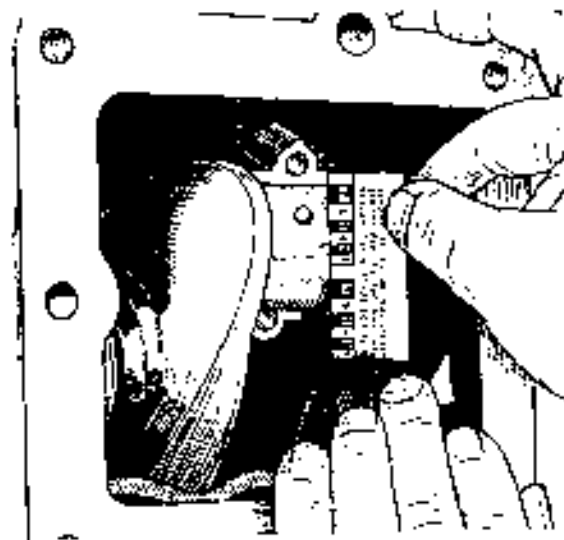

FIGURE 16-5. MEASURING BEARING CLEARANCE WITH PLASTIGAUGE

- Rotate crankshaft about 30 degrees from bottom dead center and reinstall bearing cap. Tighten bolts to the torque specified in the *Table of Torques and Clearances*. Do not turn the crankshaft.
- Remove bearing cap. Leave flattened Plastigauge on part to which it has adhered and compare widest point with graduations on Plastigauge envelope to determine bearing clearance.

Repair

1. Connecting Rod Bushing Replacement

- Press out the old bushing with a press and proper driver.
- After checking to be sure the right bushing is used, carefully press the new bushing in with the same driver used to remove the old one. Most Onan engines use precision bearings

Rev 9-76

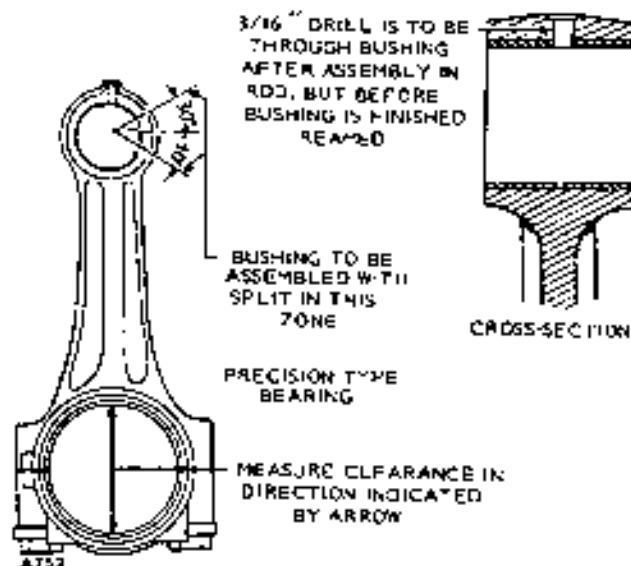
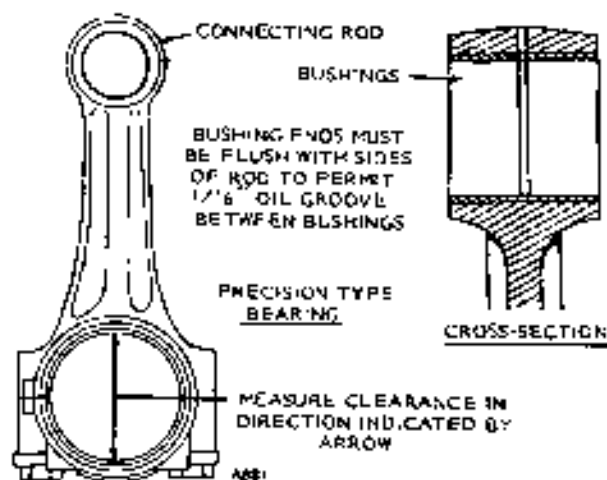

FIGURE 16-6. CONNECTING ROD BUSHINGS

that do not require reaming. Be sure that the oiler holes are at least half open to permit sufficient oiling of the pin.

On all diesel engines, two bushings are used for the connecting rod pin. Press one bushing in from each side until it is flush with the face. This will leave a 1/16 inch to 7/64 inch (1.6 to 2.78 mm) oil groove in the center (see Figure 16-6).

The piston pin bushing on the JB and JC requires a 3/16 inch (4.78 mm) drilling through the counterbored hole in the top of the connecting rod after installation, Figure 16-6. The bushing can then be finish reamed making sure the oil spray hole remains open.

- c. Check all bushings for push fit of the piston pin.

2. Connecting Rod Alignment

- a. Place connecting rod in an alignment fixture such as Onan Connecting Rod Aligning Set. This set can be used on all but AJ and AK models which require the "Small Rod Adapter."
- b. Straighten or replace connecting rods twisted more than 0.012 inch (0.31 mm) or bent more than 0.005 inch (0.13 mm).

3. Fitting Pistons

- a. Proper piston tolerances must be maintained for satisfactory operation.
- b. Measure piston as shown in Figure 16-7 to be sure total piston-to-cylinder clearance follows specifications. See Section 4 for piston dimensions.

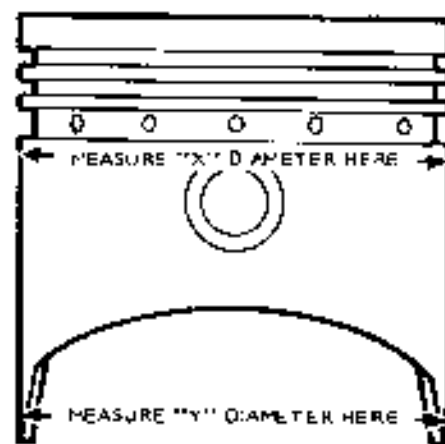

FIGURE 16-7. POSITIONS FOR MEASURING DIAMETERS OF PISTONS

4. Fitting Piston Rings

- a. Install piston ring in cylinder bore. Invert piston and push ring to end of ring travel, about halfway into bore, which trues the ring end gap. Check the gap with a feeler gauge as shown in Figure 16-8.
- b. The practice of filing ring ends to increase the end gap is not recommended. If the ring end gap does not meet specifications, check bore size for correct set of rings. A cylinder bore that is 0.001 inch (0.03 mm) undersize will reduce the end gap 0.003 inch (0.08 mm).

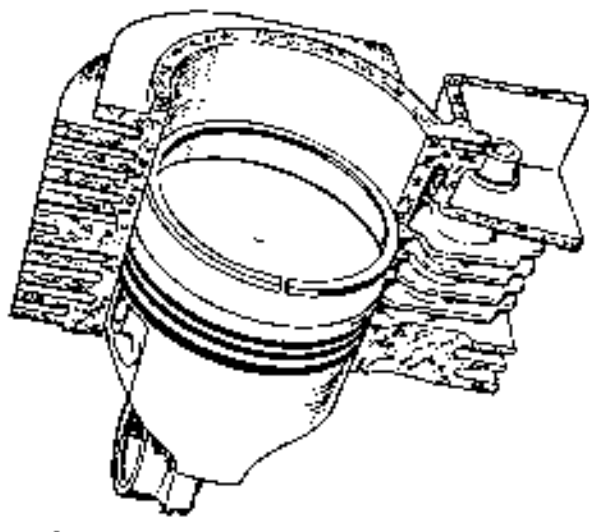

FIGURE 16-8. POSITIONING OF PISTON RING AND MEASURING OF END GAP

5. Rod Bearing Replacement (Piston in engine)

- a. Rotate crankshaft until connecting rod to which bearing is fitted is down.
- b. Remove connecting rod cap. Push connecting rod up into cylinder and remove bearing insert from rod and cap.
- c. Clean crankshaft journal and bearing inserts.
- d. Install new bearings in connecting rod and cap and pull connecting rod assembly down firmly on crankshaft journal.
- e. Insert a piece of Plastigauge on lower bearing surface according to directions in this section and install and torque the rod cap. Remove rod cap and measure clearance of new bearing according to Plastigauge width.
- f. When new bearing clearance has been checked and is found to be satisfactory, apply a light coat of engine oil to the journal and bearings.
- g. Install and torque rod cap.

Assembly

1. Lubricate all parts with engine oil.
2. Position a piston on its respective rod and install the pin.

On J-Series spark ignition engines, be sure the oil squirt hole in the rod is on the camshaft side with the indentation in the top of the piston facing the front of the engine, Figure 16-9.

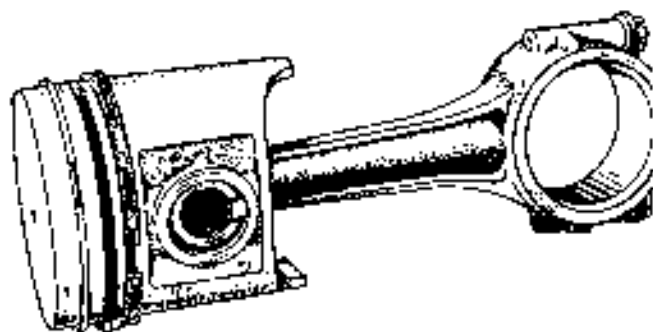

FIGURE 16-9. CONNECTING ROD ASSEMBLY FOR USE ON J-SERIES SPARK IGNITION ENGINES

On J-Series diesels built after Spec P, the valve reliefs in the piston head face the same direction as the stamped reference numbers on the connecting rod, Figure 16-10.

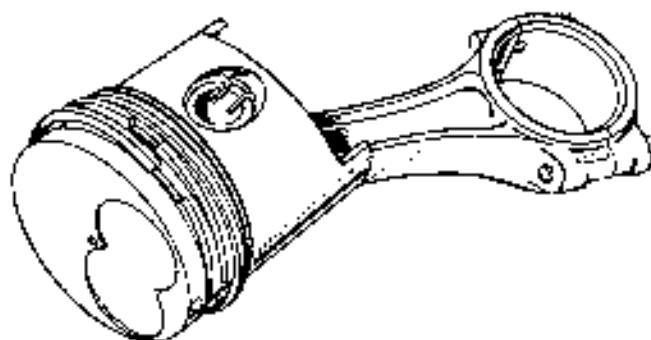
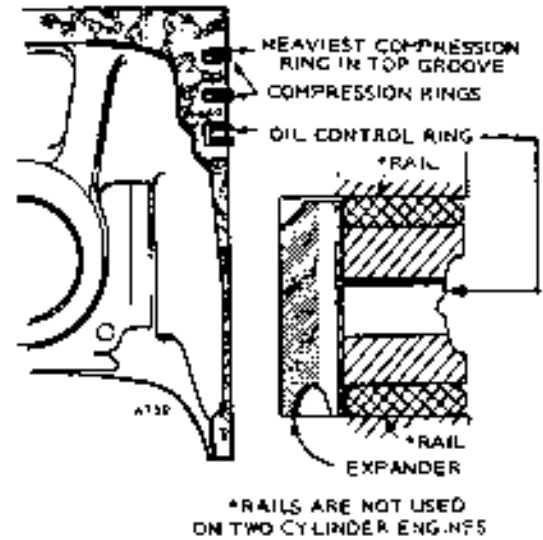
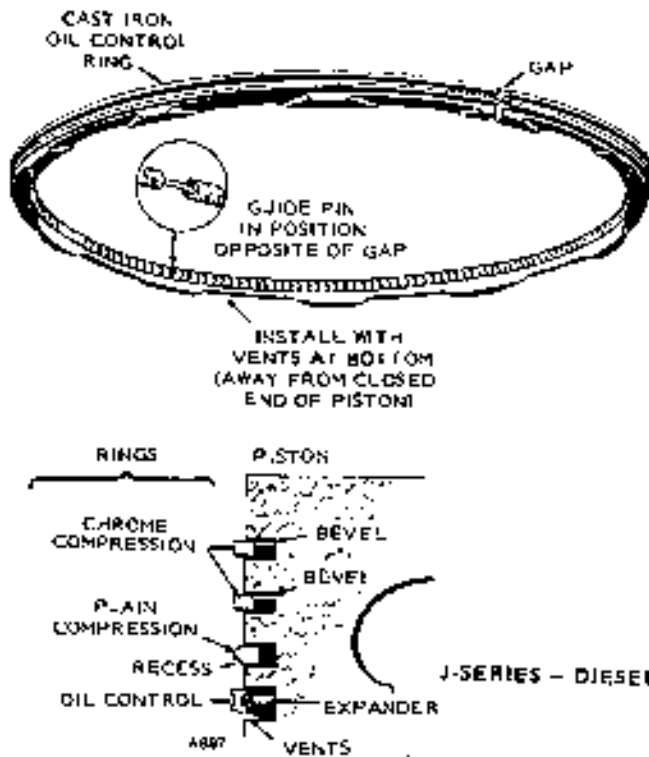

FIGURE 16-10. CONNECTING ROD ASSEMBLY FOR USE ON J-SERIES DIESEL ENGINES

CAUTION

On NHC-NHCV aluminum block, opposed piston engines, the wavy spring washer must be placed on the end of the wrist pin that faces the front of the engine on No. 1 piston. The spring washer must face the rear of the engine on No. 2 piston. Otherwise end thrust will wear out the keeper snap ring prematurely.

Since replacement rods do not have stamped reference numbers, use the bearing lock groove as a reference point because it is on the same side of the connecting rod as the stamped numbers. The number one connecting rod is not marked with a stamped number on the JB, DJA and DJB.



AK, AJ, LK, LKB, NB, CCK, CCKB, NH

FIGURE 16-11. PISTON RINGS

3. Install rings on pistons starting with the oil control ring, figure 16-11. Use a piston ring spreader to prevent twisting or excessive expansion of the ring.

Some oil control rings and all compression rings have a dot or the word "top" on one side of the ring to indicate which side faces the top of the piston. Unmarked piston rings can be installed either way. If the oil control ring has a coil expander, install the expander first, then close it until the coil ends butt. The joint should be 180 degrees from the gap of that ring.

4. Always place chrome compression rings at top of piston and plain compression ring next to oil control ring.

Installation of Piston in Cylinder

1. Turn crankshaft to position number one rod bearing journal at bottom of its stroke.
2. Lubricate number one piston assembly and inside of cylinder. Compress rings with a ring compressor as shown in Figure 16-12. Install bearing insert in rod.
3. Position piston and rod assembly in cylinder block.

CAUTION The valve recesses on the top of each piston must face toward the camshaft side of the block so the recesses align with the valves in the head. Otherwise, the piston will strike the valves at the top of their upward strokes.

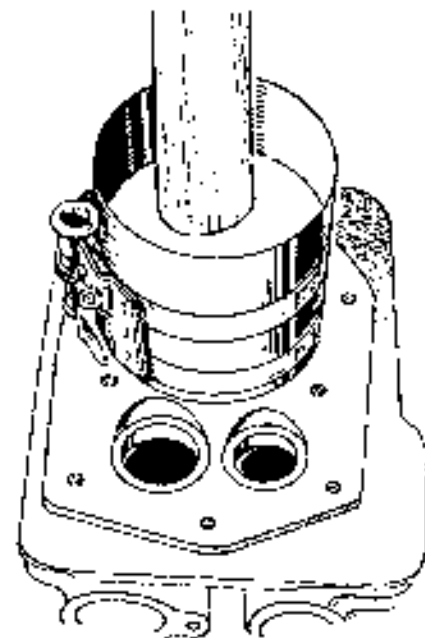

FIGURE 16-12. INSTALLING PISTON

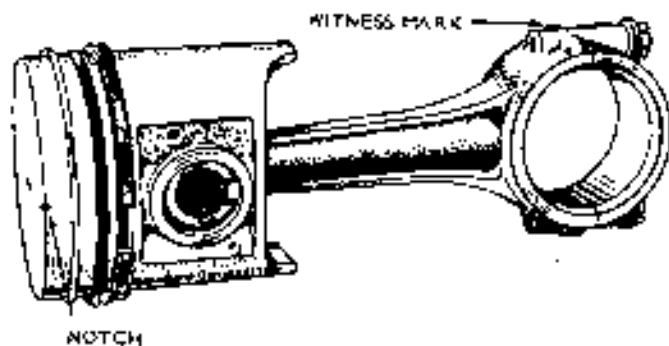

FIGURE 16-13. WITNESS MARKS

Some pistons are notched as shown in Figure 16-13. Install the piston so the notch faces the front of the engine.

The connecting rod numbers should always face the camshaft side except on the NH, which faces opposite the camshaft. The number one piston rod is rarely stamped.

All L-head engines, except the NH, have witness marks (Figure 16-13) which face the camshaft side. The NH rod has an oil squirt hole which must be on the camshaft side.

4. Tap piston down into bore with handle end of a hammer until connecting rod is seated on journal. Figure 16-12. Install the bearing cap on the rod with the witness marks and stamped reference numbers matching the marks on the rod. Install and tighten the bolts to the specified torques.

The bearing cap must be tapped several times to properly align it with the connecting rod. Clearance varies on the journal if this is not done. Install the remaining pistons and rods in the same manner. Crank the engine by hand to see that all bearings are free.

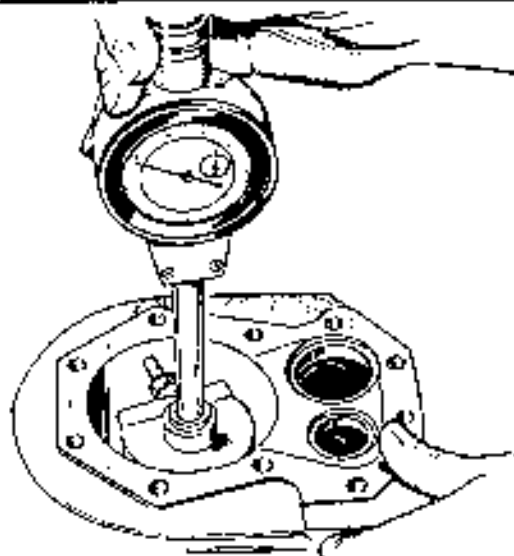
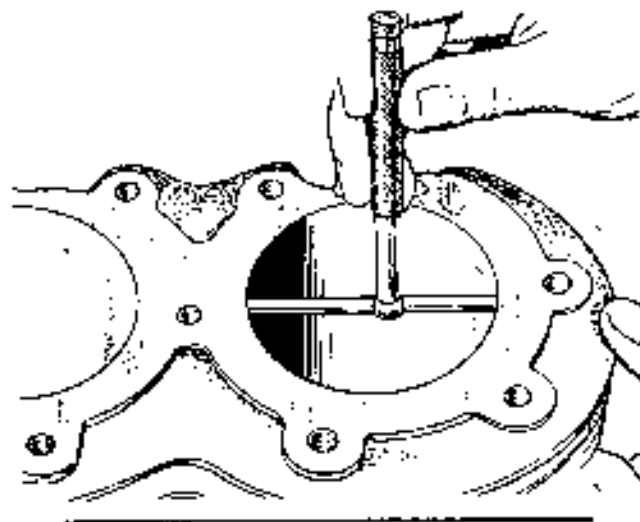

FIGURE 16-14. METHODS OF MEASURING THE DIAMETER OF A CYLINDER

measurements should be taken at four places — near top and bottom of piston ring travel.

4. Referring to Figure 16-15, measure cylinder diameter and record the readings as follows:
 - a. Measure reading A across top of cylinder where greatest piston ring wear occurs.
 - b. Measure reading B across cylinder at bottom of piston ring travel.
 - c. Measure reading C across top of cylinder where greatest ring wear occurs.
 - d. Measure reading D across cylinder at bottom of piston ring travel.
5. Compare reading A with reading B, then compare reading C with reading D to determine cylinder taper due to wear.

If taper exceeds 0.005 inch (0.127 mm), rebore and hone cylinder to accommodate the next oversize piston.

CYLINDER BLOCK

Inspection

1. Make a thorough check for cracks. Minute cracks may be detected by coating suspected area with a mixture of 25 percent kerosene and 75 percent light motor oil. Wipe the part dry and immediately apply a coating of zinc oxide (white lead) dissolved in wood alcohol. If cracks are present, the white coating will become discolored at defective area.
2. Inspect cylinder bore for scoring. Check Welch plugs for a tight, even fit and the fins for breakage.
3. Check cylinder bore for taper, out of round and wear with a cylinder bore gauge, telescope gauge or inside micrometer, Figure 16-14. These

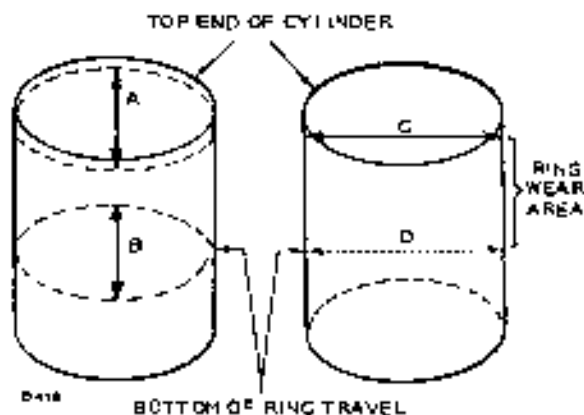

FIGURE 16-15. CYLINDER BORE MEASUREMENT

6. Reading A compared to C and reading B compared to D indicates whether or not the cylinder is out of round.

If cylinder is out of round 0.002 inch (0.051 mm), rebores and hone cylinders for next oversize piston.

HONING PROCEDURE

1. A hone can be used to rebores a cylinder. Figure 16-16. Remove stock to 0.002 inch (0.051 mm) less than finished bore with coarse hone (100 grit), then complete honing with finish hones (300 grit).
2. Anchor block solidly for either vertical or horizontal honing. Use either a drill press or heavy-duty drill which operates at about 250 to 450 rpm.
3. Lower hone into cylinder until it protrudes 1/2 to 3/4 inch (13 to 19 mm) past end of cylinder. Rotate adjusting nut until stones come in contact with cylinder wall at narrowest point.

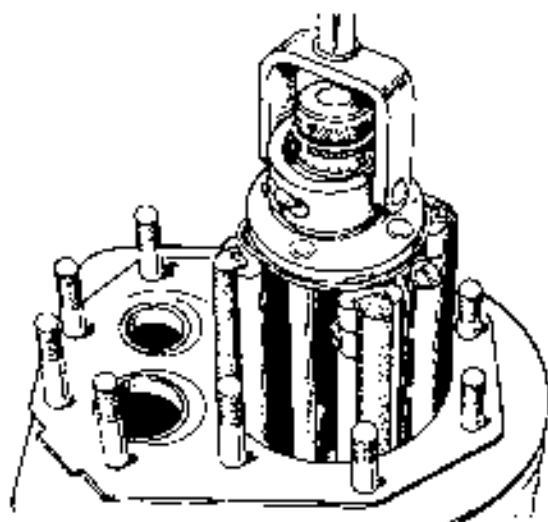

FIGURE 16-16. HONING CYLINDER

4. Loosen adjusting nut until hone can be turned by hand.
5. Connect drill to hone and start drill. Move hone up and down in the cylinder about 40 cycles per minute. Usually the bottom of the cylinder must be worked out first because it is smaller. When cylinder takes a uniform diameter, move hone up and down all the way through the bore. Follow the hone manufacturer's recommendations for wet or dry honing and oiling the hone.
6. Check diameter of cylinder regularly during honing. A dial bore gauge is the easiest method but a telescoping gauge can be used. Check the size at six places in the bore; measure twice at the top, middle and bottom at 90-degree angles.
7. When the cylinder is about 0.002 inch (0.051 mm) within the desired bore, change to fine stones and finish the bore. The finish should not be smooth but as shown in Figure 16-17. The crosshatch formed by the scratching of the stones should form an angle of 32 degrees. This can be achieved by moving the hone up and down in the cylinder about 40 cycles per minute.

8. Clean cylinder block thoroughly with soap, water and clean rags. A clean white rag should not be soiled on the wall after cleaning is complete.

CAUTION

Do not use a solvent or gasoline since they wash the oil from the walls but leave the metal particles.

9. Dry crankcase and coat it with oil.

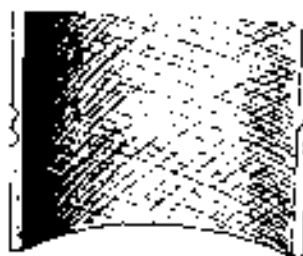

PRODUCE CROSS HATCH SCRATCHES FOR FAST RING SEATING



AVOID THIS FINISH

FIGURE 16-17. CORRECT HONE FINISH

SECTION 17.

CRANKSHAFT AND MAIN BEARINGS

INDEX

GENERAL	17-1
Troubleshooting.....	17-1
CRANKSHAFT REMOVAL	17-2
INSPECTION	17-2
CRANKSHAFT REPAIR AND REPLACING	17-3
MAIN BEARINGS	
General.....	17-3
Bearings.....	17-3
Front Main Bearing Installation.....	17-4
Crankshaft Installation.....	17-5
Crankshaft Endplay.....	17-6
Front and Rear Main Bearing Oil Seals.....	17-6
CAMSHAFT AND BEARINGS	17-7
Removal of Camshaft.....	17-7
Inspection and Repair.....	17-8
Camshaft Gear.....	17-8
Camshaft Bearings.....	17-8
Installation of Camshaft.....	17-10

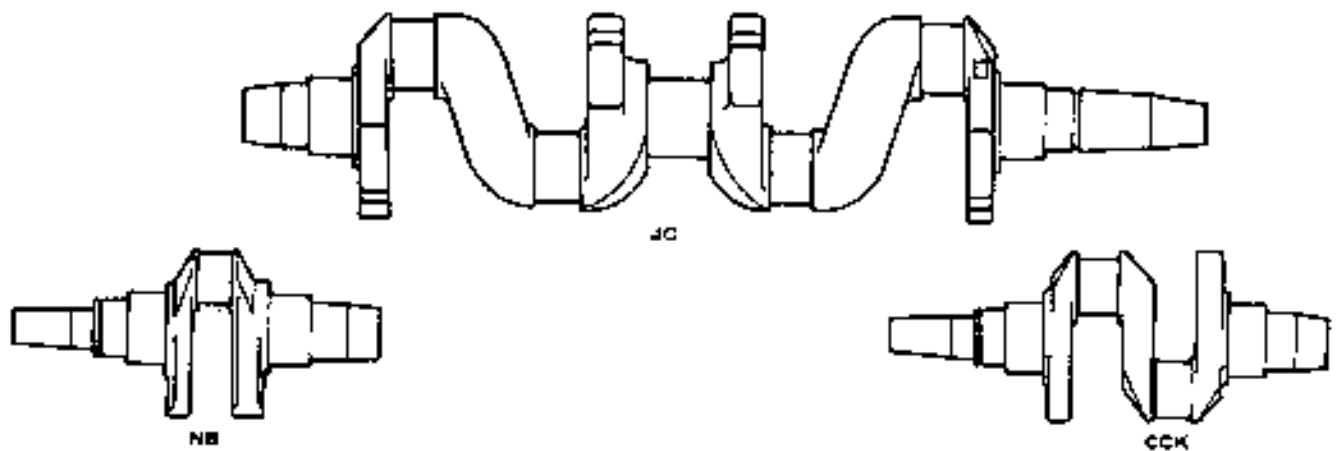

FIGURE 17-1. CRANKSHAFTS

GENERAL

Onan engines use a counterbalanced, cast iron or ductile iron crankshaft. On diesel engines, to increase the shaft's fatigue durability, the crankpin fillets are shot-peened during manufacturing. Figure 17-1 illustrates typical crankshafts used on Onan engines. On one and two cylinder engines the crankshaft rides on two bearings; the front one housed in the engine crankcase and the rear one housed in the rear bearing mounting plate. The four cylinder J-Series models use an additional split center main bearing.

Troubleshooting

Expecting to receive good service from your engine after overhaul means learning to recognize crankshaft problems. Worn crankshaft main bearing journals allow too much play between the crankshaft and bearings, causing low oil pressure and the oil seal to leak. A partially sheared keyway or twisted shaft also throws timing off.

Check for the following when diagnosing crankshaft problems.

1. **Excessive Vibration:** Excessive vibration indicates a bent crankshaft.
2. **Noisy Operation:** Worn bearings, especially rod bearings increase engine noise.
3. **Leaky Crankshaft Oil Seals:** Oil leaks could indicate a bent crankshaft, bad oil seals, worn bearings or a combination of the above.
4. **Chronic Timing Problems:** Chronic timing problems not eliminated by engine tune-up indicate crankshaft wear.
5. **Bent or Warped Crankcase:** If you cannot rotate the crank by hand either way, this could indicate a bent crankshaft, a seized bearing, seized piston, hydraulic lock, jammed starter, etc. Bent crankshafts are checked with a dial indicator either in lathe centers or vee blocks. If a new crank is installed and binding, a warped crankcase could be the cause.

6. **Crankshaft Endplay:** Before removing the crankshaft, check the endplay (Figure 17-2) to determine if it is excessive or not. Too much endplay allows the shaft to move back and forth, causing excessive pounding of the bearings and thrust washers. Too little endplay causes excessive pressure against the thrust washers.

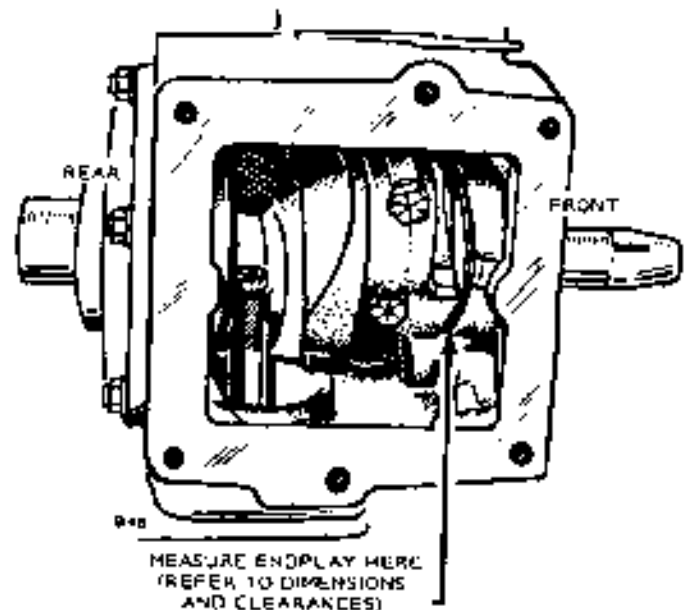
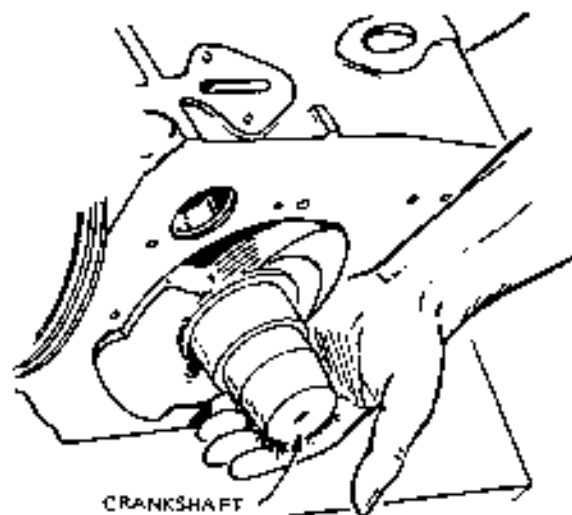

FIGURE 17-2. CRANKSHAFT ENDPLAY



CRANKSHAFT

FIGURE 17-3. CRANKSHAFT REMOVAL

CRANKSHAFT REMOVAL

1. Remove lock ring and retaining washer from in front of crankshaft gear. Figure 17-3.
2. Pull off crankshaft gear, using proper gear puller. See *Tool Section*.
3. Remove oil pan, cylinder head or heads, piston or pistons and connecting rod.
4. Remove bearing cap (J-Series).

Label each bearing cap for eventual replacement on its journal. Bearing caps should not be returned to their journals facing the opposite direction they originally faced. Scribe a line on the bearing housing and bearing cap before bearing removal.

5. Remove rear bearing plate from crankcase.
6. Remove crankshaft through rear opening in crankcase. On four cylinder J-Series models, catch the upper half of the center main bearing support as it slides off its mounting surface. See Figure 17-4.

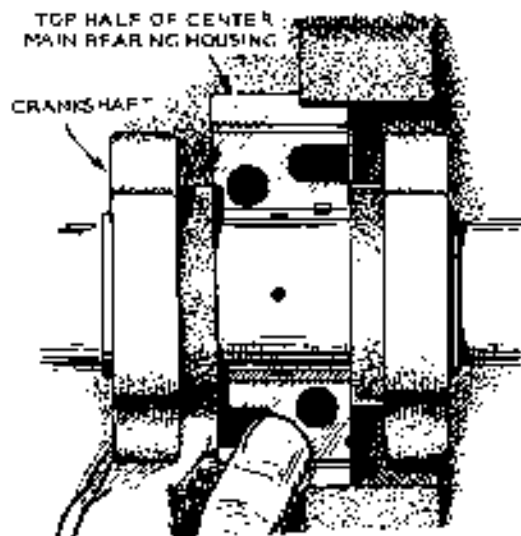

FIGURE 17-4. CATCHING CENTER MAIN BEARING SUPPORT

INSPECTION

Clean the crankshaft in a suitable solvent and blow out all oil passages. Check the journals for out of round, taper, grooving or ridges, Figure 17-5. Look for ridges or grooves on either side of the oil hole areas. This indicates infrequent oil changes. If the journal dimensions are not within limits (see *SPECIFICATIONS* section of this manual), or if the journals are scored, regrind the crankshaft.

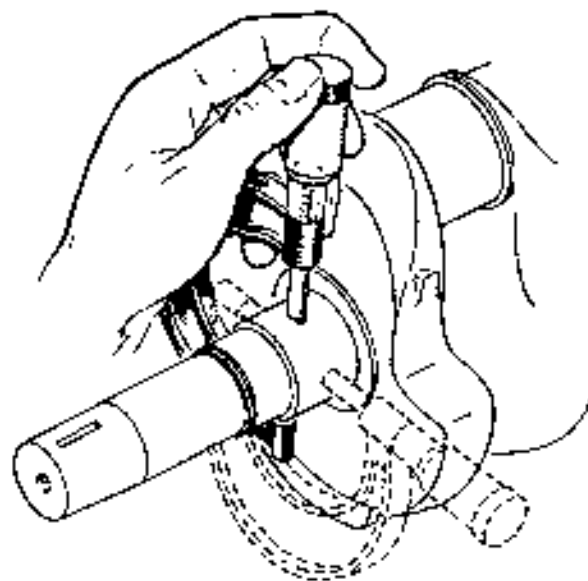

FIGURE 17-5. MEASURING CRANKSHAFT JOURNAL

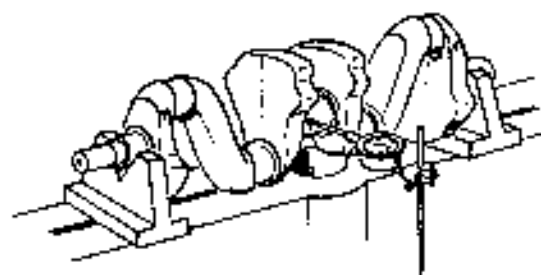

FIGURE 17-6. CHECKING CRANKSHAFT RUNOUT

Place the crankshaft on "V" blocks to check the runout at the center journal with a dial indicator. Replace the shaft if runout exceeds .003 inch (0.08 mm), Figure 17-6. Replace the crankshaft gear if worn or chipped. Measure each journal in at least four places to determine the wear, out of round and taper, Figure 17-7. If the out of round is in excess of .005 inch (0.13 mm), the taper more than .001 inch (0.03 mm), or wear more than .002 inch (0.05 mm), regrind the shaft for the next undersize bearings or replace the shaft, Figure 17-8.

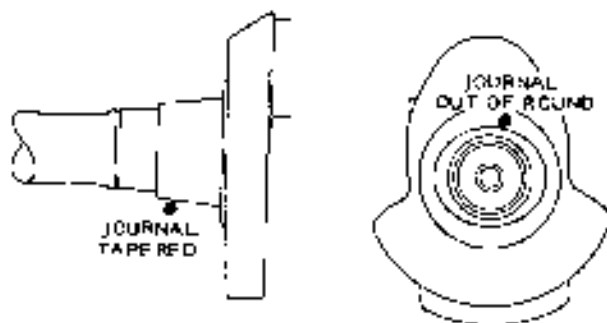

FIGURE 17-7. OUT OF ROUND AND TAPER

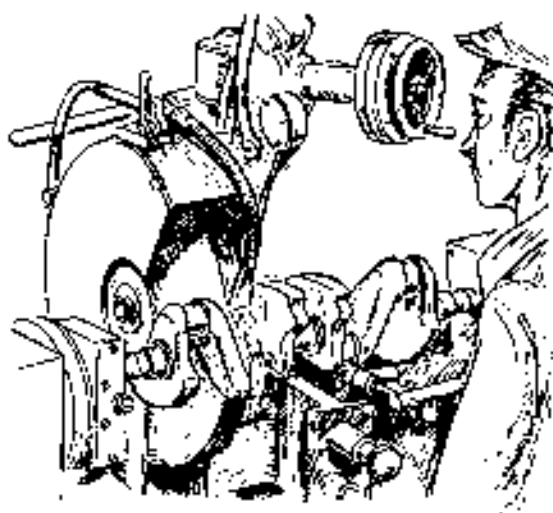

FIGURE 17-8. CRANKSHAFT REGRINDING

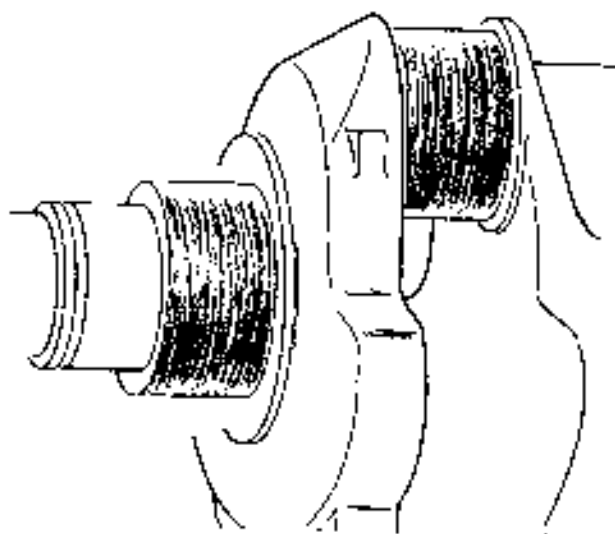

FIGURE 17-9. SCORED AND WORN CRANKPINS AND JOURNALS

CRANKSHAFT REPAIR AND REPLACING MAIN BEARINGS

General

On engines which are subjected to full load operation over long periods of time it is important that the crankshaft journals and crankpins be round, smooth and straight. Regrinding a crankshaft requires accuracy, precision machinery and an experienced operator. Any crankshaft having journals or crankpins which exceed the minimum or maximum specifications shown in Section 4 must be reground. Crankshafts with rough or scored journals or crankpins must be reground, Figure 17-9.

Shot-peening the NHC engines prior to Spec B and diesel engine crankshafts require special care. In addition to machining, the crankshaft must be shot-peened and super finished. Failure to shot-peen the crankpin fillets causes early failure due to cracking. See Figure 17-10 for shot-peening data concerning diesel J-Series and NHC (prior to Spec B) engines.

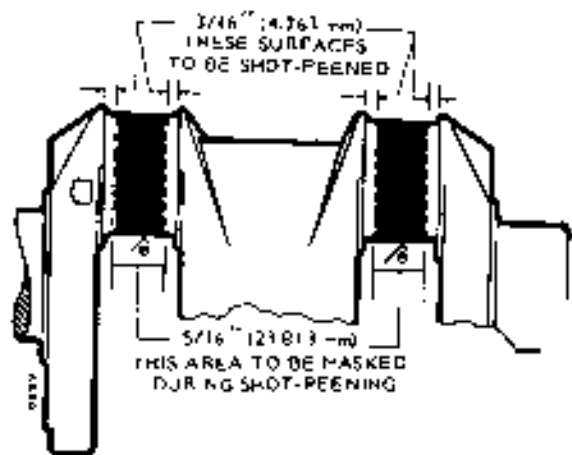

FIGURE 17-10. SHOT-PEENING DIESEL CRANKSHAFTS

Proceed as follows.

Mask off connecting rod bearing areas.

2. Almen gauge reading .012-A.
3. Peen with .019 inch (4.83 mm) diameter cast steel shot.
4. Peen for 30 seconds on each crankpin fillet.

Undersize bearings are available to rework the crankshaft to .010 inch, .020 inch and .030 inch (0.25 mm, 0.51 mm and 0.76 mm) undersize.

Bearings

Examine the old rod and main bearing. Look at the backs of the rod bearings for evidence that the rod bores are oversized and unfit for further use. If a rod bearing has failed for no apparent reason or if the backs of the bearings indicate excessive movement or

excessive heat, check rod alignment and possible enlarged bore size. Main bearings that are warped, scored, show signs of being overheated or are otherwise damaged. Indicate that the main bearing bores in the block and rear main bearing plate should be checked for proper dimension.

If the front main bearing seat is damaged beyond the point where a new bearing can be effectively press fit in place, discard the entire engine block.

A new rear main bearing seat can be installed by replacing the rear main bearing plate. Check main bearing bore alignment on a line boring machine.

Front Main Bearing Installation: Crankshaft main bearings are precision type (Figure 17-11) and do not require line reaming or line boring after installation. They are available in .002 inch, .010 inch, .020 inch and .030 inch (0.05 mm, 0.25 mm, 0.51 mm and 0.76 mm) undersize. Before attempting to install the bearing, the bearing bore may be heated. This expands the bore and allows for easier seating of the bearing. The bearing may also be cooled to shrink it, providing easier installation.

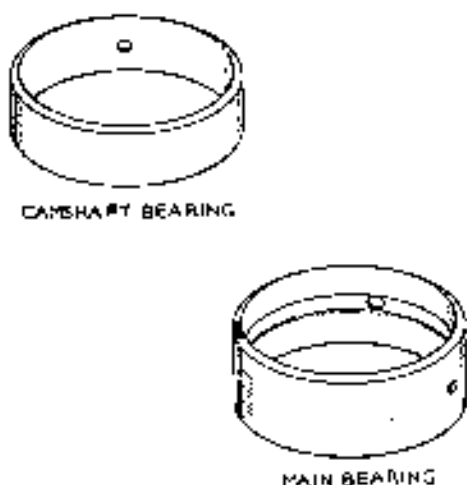

FIGURE 17-11. PRECISION TYPE BEARING

If the bearing bore has been heated or the bearing cooled, oil the bearing and tap it lightly into place (Figure 17-12) using Onan tool as indicated in tool catalog in this manual. Make sure oil holes are lined up.

All engines except NH series after Spec C use thrust washer bearings along with the front and rear main bearings. NH engines after Spec C use a thrust washer and main bearing for the rear bearing plate while the front of the engine uses a one piece bearing. All NH engines should now use the one piece bearing for overhaul or repair, Figure 17-13.

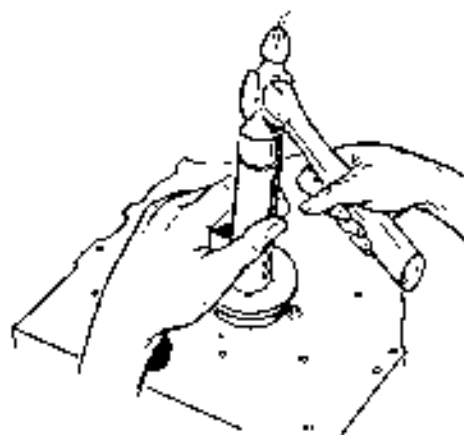

FIGURE 17-12. BEARING SEATING

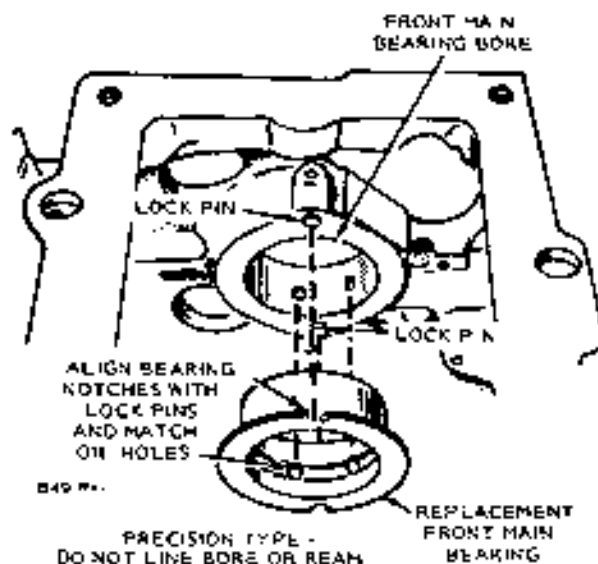

FIGURE 17-13. FRONT MAIN BEARING INSTALLATION—NH ENGINE

Before installing the front bearing on NH engines, use the Locktite Bearing Mount furnished in the bearing kit. Use the towelette in the package to clean the outside of the bearing and the bearing bore in the block.

WARNING Breathing vapor from towelette and prolonged contact with skin can be harmful. Be sure area is well ventilated.

On all engines, always align the oil holes in the bearing with the oil holes in the bearing bore. Oil passages must be at least one half open.

In the rear bearing plate (Figure 17-15), install the bearing flush to 1/64 inch (0.397 mm) below the end of the bore, using a bearing driver. (See Onan Tool Catalog in this manual for the correct tool number.) If a special combination tool is not available and it is necessary to remove the lock pins with side cutters or easy-out tool, always insert new lock pins.

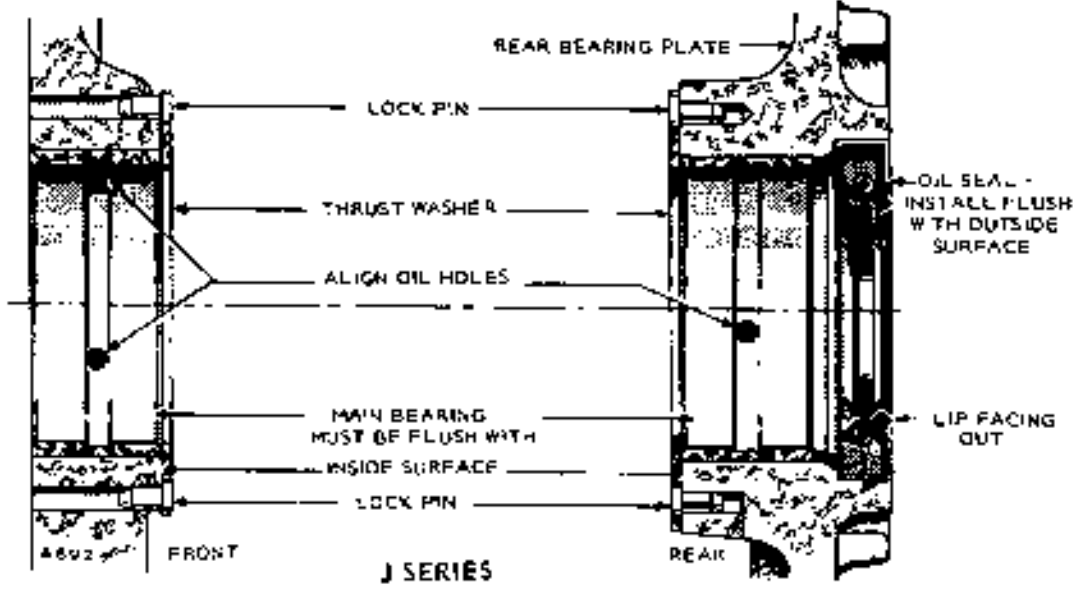
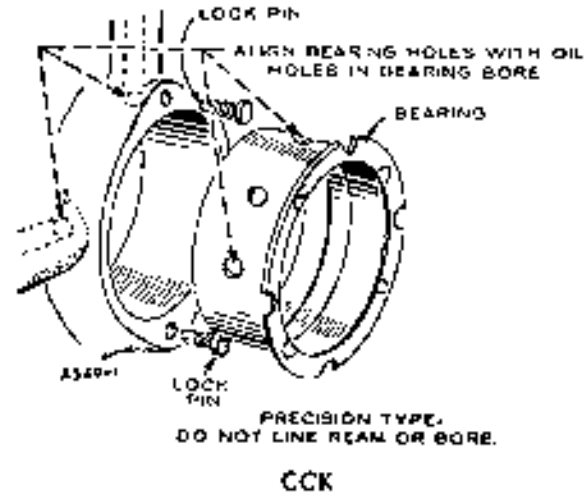
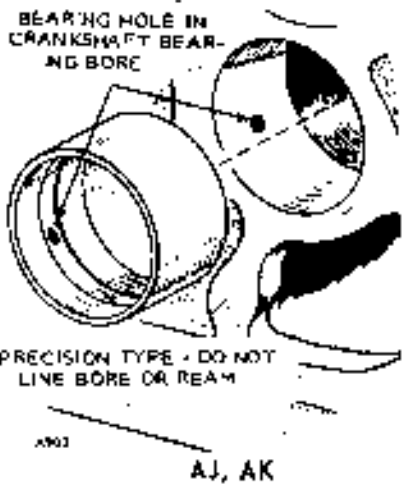

FIGURE 17-14. MAIN BEARING INSTALLATION

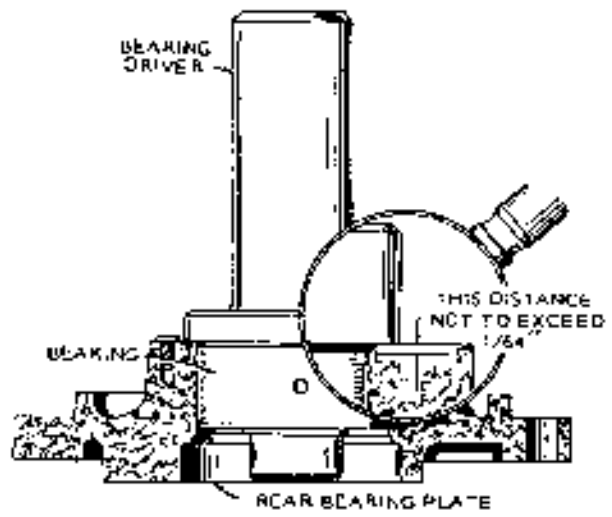

FIGURE 17-15. REAR BEARING PLATE BEARING INSTALLATION

Crankshaft Installation

After each installation step, check the crankshaft to be sure it is not frozen into place.

1. Oil bearing surfaces and install crankshaft from rear of crankcase through rear bearing plate hole.
2. With rear bearing plate gasket in place and rear end plate bearing lubricated, slide thrust washer (grooves toward the crankshaft) and plate over end of crankshaft.

CAUTION Line up notches of thrust washer with lock pins before tightening down and plate or the lock pins and thrust washer will be damaged.

A light film of oil on the thrust washer may hold it in place while installing the crankshaft.

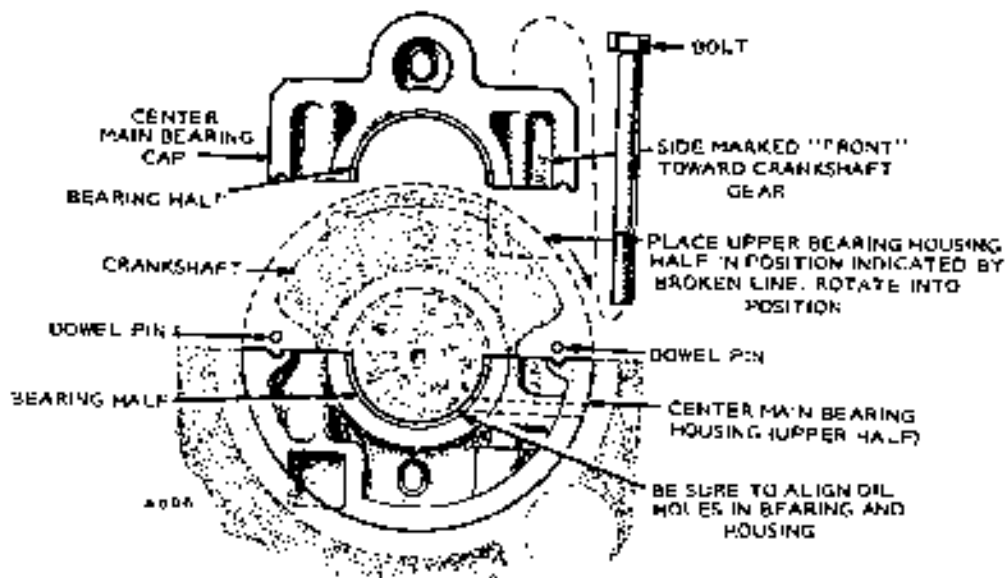

FIGURE 17-16. CENTER MAIN BEARING INSTALLATION—J-SERIES

3. Torque down bearing plate.
4. Heat timing gear on an electric burner or oven to about 350° F (177° C). Install a new crankshaft key and drive the gear into place. Install retaining washer and lock ring.
5. *Four Cylinder J-Series Engines Only:* Set upper half of the center main bearing (Figure 17-16) on crankshaft and rotate it into place. The side of the bearing marked front must be toward the crankshaft gear. Set the two position dowels on the upper bearing mount. Install the center main bearing cap and torque the bolts to 97 to 102 ft. lbs. (132 to 138 N•m).
6. Check crankshaft endplay.
7. Install piston assemblies.

Crankshaft Endplay

After the rear bearing plate is tightened (using the torques recommended in the *SPECIFICATIONS* section of this manual), check for crankshaft endplay, Figure 17-17.

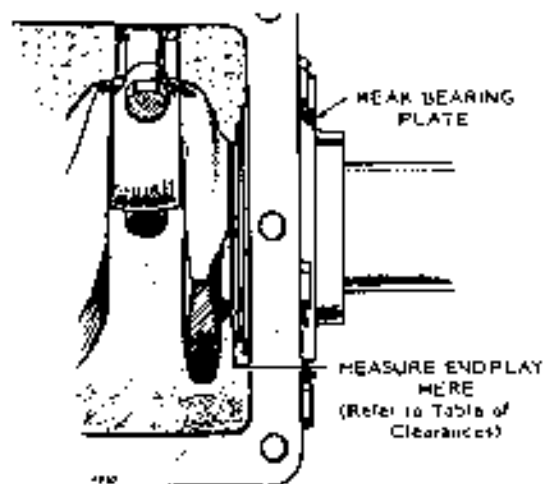

FIGURE 17-17. CRANKSHAFT ENDPLAY

If there is too much endplay, remove the rear bearing end plate and add a shim between the thrust washer and plate, Figure 17-18. Reinstall the end plate, lining up the thrust washer and shim notches with the lock pins. Torque the end plate and recheck for crankshaft endplay. If gaskets of more than .015 inch (0.38 mm) total thickness are required, use a steel shim of the proper thickness and a thin gasket on each side of the shim. This avoids excessive gasket compression and maintains bolt torque.

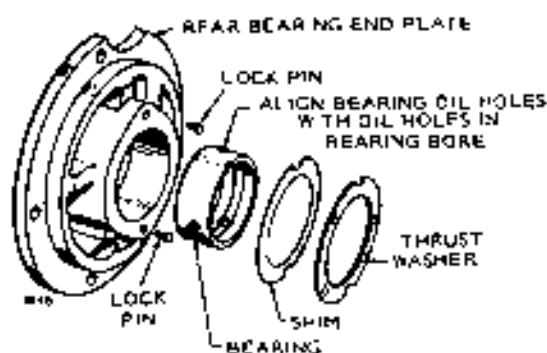

FIGURE 17-18. SHIM INSTALLATION

Front and Rear Main Bearing Oil Seals

The front engine oil seal is located in the gear cover and the rear main oil seal is located in the crankshaft end plate. The rear bearing plate must be removed to replace its oil seal. Follow these instructions when changing front or rear seals.

1. Drive oil seal out from inside, using appropriate bearing plate or gear cover driver (see tool section).

2. Before installing seals, fill space between the seals with a fibrous grease or stiff cup grease. This improves sealing, Figure 17-19.

Use heavy fiber or cup grease in space between seals to improve seal.

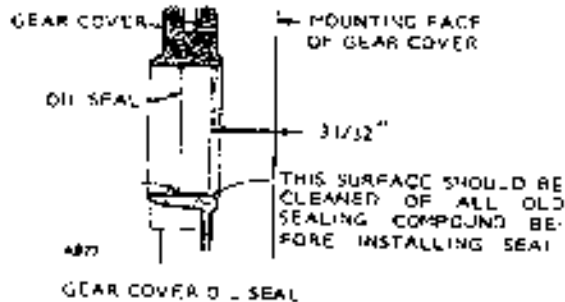

GEAR COVER OIL SEAL

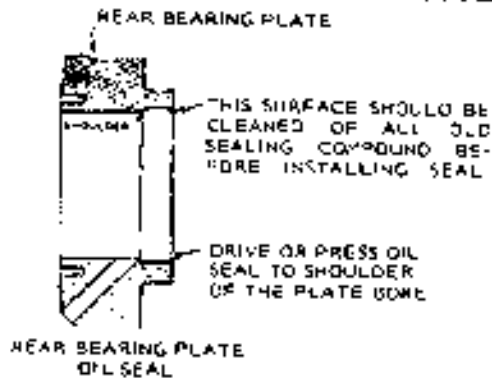

REAR BEARING PLATE OIL SEAL

FIGURE 17-19. GEAR COVER AND REAR BEARING PLATE OIL SEALS

3. Lay gear cover on a bench so seal boss is supported. Using a gear cover driver, insert a new seal from inside with the rubber lip toward the outside of the gear cover (open side of seal inward) and drive it flush with the outside surface.

On NH engines, tap gear cover oil seal inward until it is $3/32$ inch (24.81 mm) from the mounting face of the gear cover. Install the new style, thin open face seal, $5/16$ inch (26.18 mm) from mounting face of the cover.

4. When installing bearing plate oil seal, tap new seal in until it bottoms flush with rear surface of bearing plate, Figure 17-20. Use a seal expander or place a piece of shim stock around the end of the crankshaft when replacing the bearing plate to avoid damaging the seal. Remove shim stock as soon as plate is in place.

Engines equipped with some types of reduction gear assemblies do not use a rear oil seal. The reduction gear assemblies are oiled directly from the engine crankcase. See instructions on the case of the reduction gear assembly.

CAMSHAFT AND BEARINGS

The camshaft is a one piece machined casting, driven through gears by the crankshaft. The camshaft rides on sleeve bearings pressed into the crankcase, Figure 17-21. In addition to opening and closing the valves, the camshaft operates the fuel pump and breaker points.

Removal of Camshaft (J-Series Engines But Similar on all Engines)

1. Remove rocker arms and pushrods from valve chambers.
2. Remove fuel pump from engine. Remove distributor (RJC only).

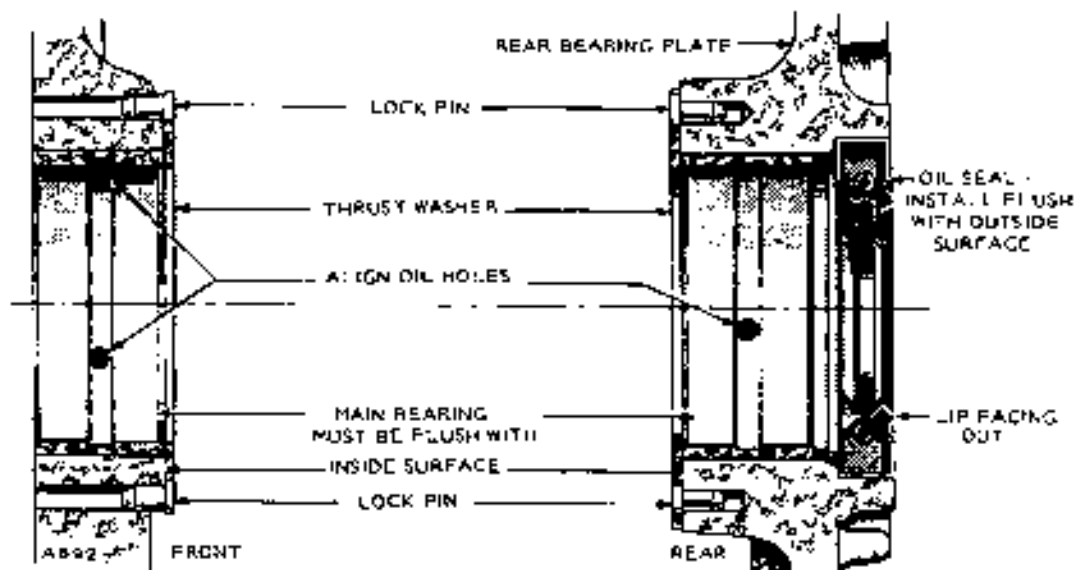

FIGURE 17-20. INSTALLING REAR BEARING PLATE OIL SEAL

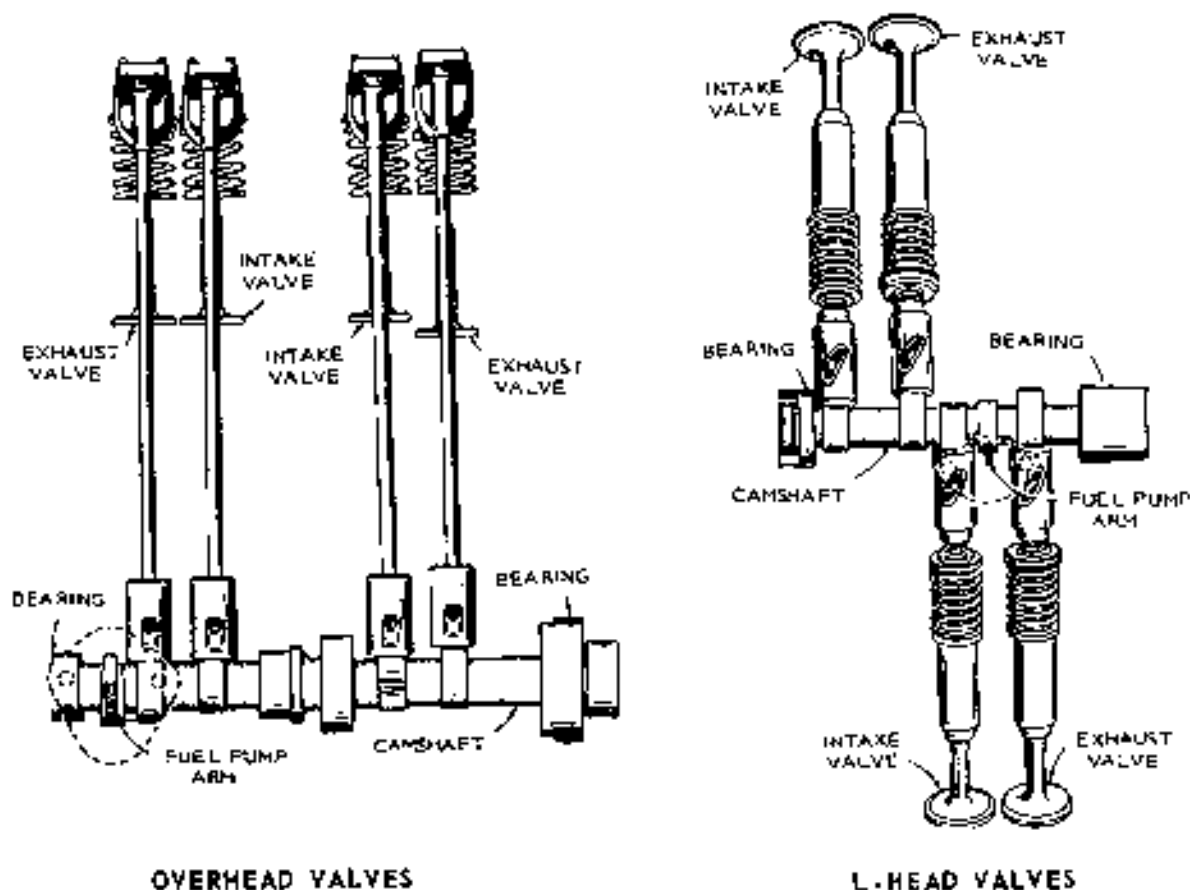

FIGURE 17-21. CAMSHAFT

3. Remove injection pump and fuel transfer pump from engine (diesel engines only).
4. Remove crankshaft gear retaining washer by removing lock ring on crankshaft.
5. Lay engine on its side to avoid dropping tappets and remove camshaft assembly as a group. If necessary, pry it out with a screwdriver placed between camshaft gear and crankcase.
6. Remove tappets from camshaft end of pushrod holes.

On four cylinder J-engines, either the oil base or cylinder heads and pushrod tubes must be removed to remove the tappets. Tappets on all other engines can be removed from the valve chamber or camshaft side of tappet bores by reaching inside the crankcase after cam is removed.

Inspection and Repair

Inspect the cam lobes carefully. If the camshaft is badly worn or scored, replace it (see *SPECIFICATIONS* section of this manual for cam dimensions). Inspect the tappet faces which ride on the cam lobes for signs of fatigue. Measure the camshaft journals with a micrometer for wear.

Valve cam lobes (Figure 17-21) are designed in an

egg-shaped oval contour to provide:

- Clearance of a few thousandths of an inch during part of the cycle when the valves must be closed.
- A shape that causes valve rotation.
- A ramp for engaging the valve and starting its lift.
- A portion that accelerates the valve to maximum opening velocity.
- A section that decelerates the valve to a stop on the nose of the cam.
- The opposite half of the cam lobe that allows the valve to close by a similar sequence.

Camshaft Gear: The camshaft gear is press fit on the camshaft and driven at 1/2 the crankshaft speed. To remove the gear, use a hollow tool or pipe that will fit inside the gear bore and over the center pin. Press the camshaft out of the gear bore. Be careful; not to damage the center pin.

Camshaft Bearings: Camshaft bearings must be replaced if the camshaft clearance is greater than specified in the *SPECIFICATIONS* section. Replace bearings with cracks, breaks, burrs, excessive wear or other damage. To check the rear camshaft bearing, remove the expansion plug at the rear of the crankcase.

Use a press or suitable driving plug to remove the camshaft bearings. Support the casting to avoid damaging the bearing bore during removal and installation. Use oil on the bearings to reduce friction when installing and again on bearing surfaces after installation. Use the bearing driver listed for your engine in the tool catalog in this manual.

Replacement camshaft bearings (Figure 17-22) are precision type and do not require line reaming or line boring after installation. Place the bearing on the crankcase over the bearing bore with the lubricating hole (front only) in the proper position, Figure 17-22. Be sure to start the bearing straight. Press the front bearing in flush with the outside end of the bearing bore. Press the rear bearing in until just past the ignition plunger hole (Figure 17-23) on one and two cylinder models, except J-Series. On J-Series engines, press the rear bearing flush with the bottom of the expansion plug recess.

another free manual from www.searstractormanuals.com

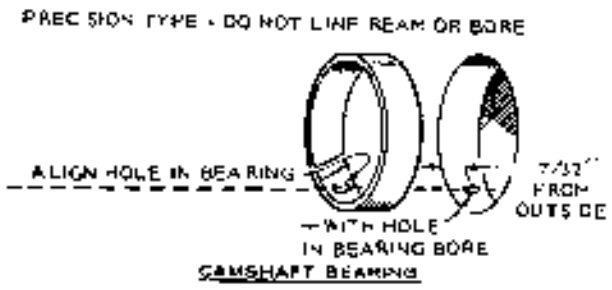
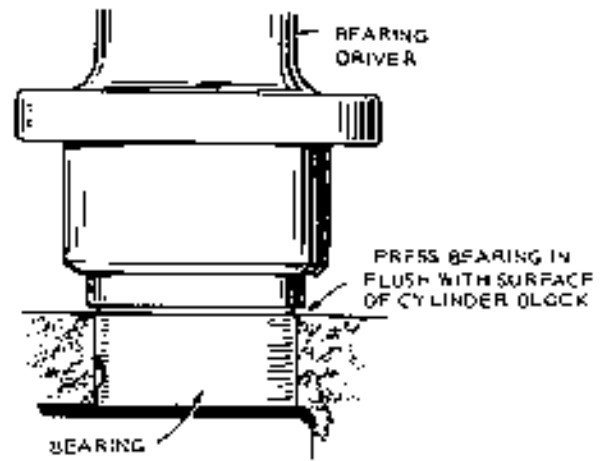
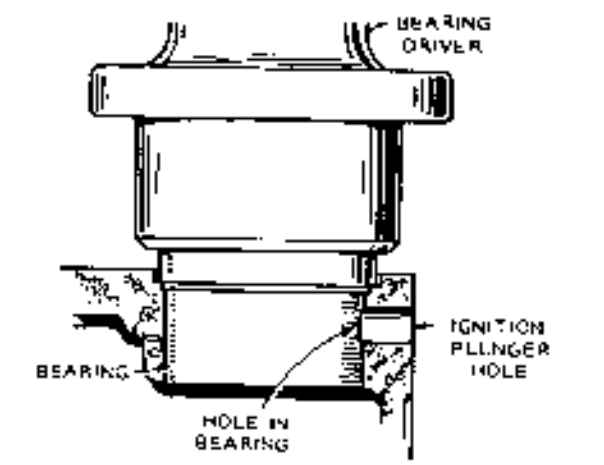

FIGURE 17-22. ALIGNMENT OF PRECISION TYPE BEARING



FRONT CAMSHAFT BEARING



REAR CAMSHAFT BEARING

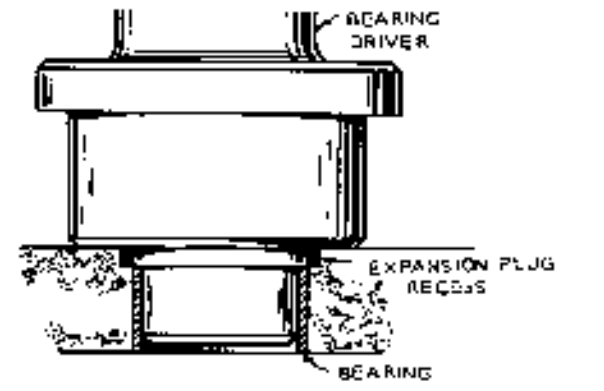

REAR CAMSHAFT BEARING

J SERIES

FIGURE 17-23. PRESSING IN REAR BEARING

Installation of Camshaft (J-Series Engine, But Similar on all Engines)

1. Install key and press camshaft gear on its shaft.
2. Install governor components.
3. Slide thrust washer on to shaft. Measure camshaft endplay (Figure 17-24). See *SPECIFICATIONS* section for clearances.
4. Lay engine on its side or end and insert pushrod tappets.
5. Install camshaft assembly in engine. Align timing marks on camshaft gear and crankshaft gear, Figure 17-25.
6. Replace fuel pump and pushrods. Install and retune distributor (RJC only).
7. Install fuel transfer pump (J-Series diesel engines).
8. When engine is reassembled, install injection pump following the steps for injection pump installation in the *DIESEL FUEL SYSTEM* section of this manual. This step is critical.

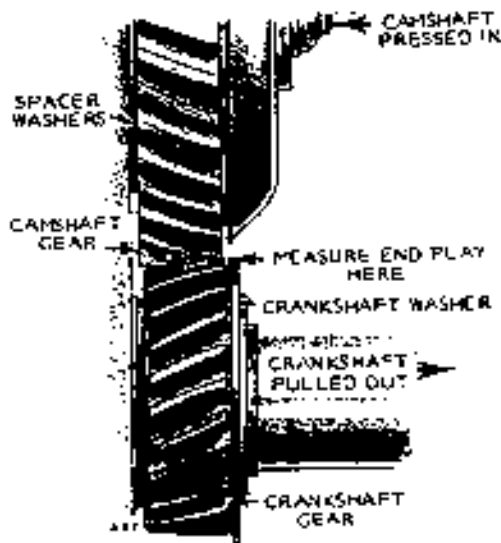

FIGURE 17-24. MEASURE CAMSHAFT ENDPLAY

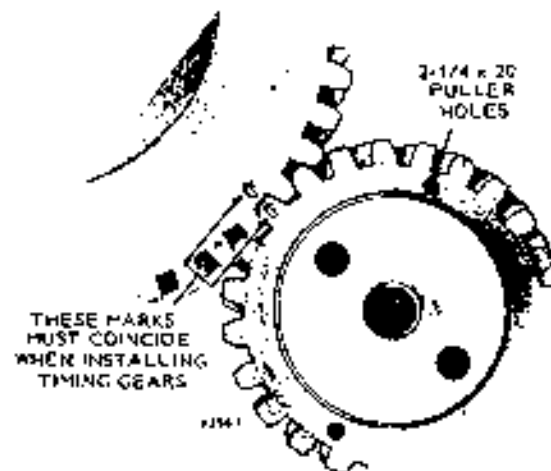
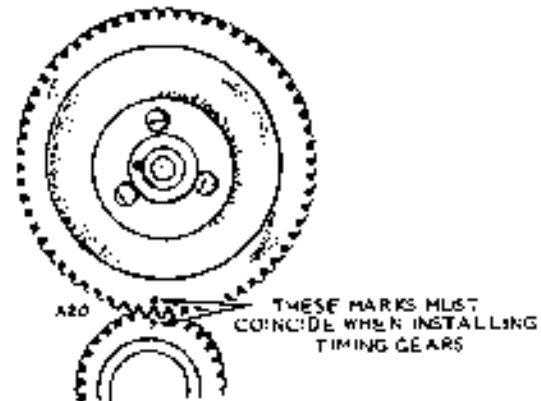

FIGURE 17-25. ALIGNING TIMING MARKS

SECTION 18.

STARTING SYSTEMS

AK, AJ MANUAL STARTERS	18-1
Starter Installation	18-1
Starter Disassembly	18-1
Cord Replacement	18-1
Rewind Spring Replacement	18-1
Starter Assembly	18-1
Troubleshooting	18-3
LK, CCK, NB, NH MANUAL STARTERS	18-3
Readi-Pull Starter	18-3
Installing CCK Starter Units Prior to Spec D	18-4
Installing Read-Pull Starter CCK Units Spec D and Later, LK, NB and NH Units	18-5
AUTOMOTIVE TYPE ELECTRIC STARTING	18-6
TROUBLESHOOTING AND MAINTENANCE OF AUTOMOTIVE TYPE STARTING SYSTEMS	18-7
Cranking Motor	18-7
Solenoid Shaft	18-7
Testing Solenoid Shift Starter	18-7
Bendix Drive	18-7
REPAIR OF STARTING UNIT	18-8
Disassembly	18-8
INSPECTION OF PARTS	18-10
Testing of Armature for Shorts	18-10
Testing of Armature for Grounds	18-10
Testing of Armature for Open Circuit	18-10
Testing Commutator Runout	18-10
Testing Armature Shaft Runout	18-10
Testing Field Coils for Grounds	18-10
Testing Field Coils for Open Circuit	18-11
Inspection of Brushes	18-11
Inspection for Brush Spring Tension	18-11
Assembly	18-11
Inspection After Overhaul	18-11
Adjusting Pinion Clearance	18-12
EXCITER CRANKING	18-12
BF, NH POWER DRAWER UNITS	18-13
Starter Removal	18-13
STARTER DISASSEMBLY	18-13
CLEANING PARTS	18-14
INSPECTION OF PARTS	18-14
BRUSH REPLACEMENT	18-15
Brush Springs	18-15
Overrunning Clutch	18-15

REASSEMBLY.....	18-15
TESTING AND ADJUSTING	18-16
Adjusting Pinion Clearance	18-16
No Load Test.....	18-17
BF TRACTOR STARTER.....	18-17
Starter Disassembly	18-17
INSPECTION OF PARTS	18-17
BRUSH SERVICE.....	18-17
Brush Inspection	18-17
Brush Spring Inspection	18-17
STARTER ASSEMBLY	18-17
REASSEMBLY (SPEC B).....	18-18
INSPECTING REASSEMBLED STARTER.....	18-18
No Load Test.....	18-18

AK, AJ MANUAL STARTERS

Starter Installation: Follow each step in proper sequence. Refer to Figure 18-1 for visual aid.

1. Remove the flywheel screw. Leave the existing rope sheave in place. The washers and screw are also reused. The sheave provides easier emergency cranking than the starter cup.
2. Secure cup no. 2 by placing lock washer no. 26 and flat washer no. 24 between cup and capscrew no. 23 (Figure 18-1).
3. Assemble the mounting ring no. 3 (sometimes called bracket) to the starter (if not already so attached) using the four screws no. 4 and selecting the correct one of four possible positions to give the desired direction of rope pull.
4. Prior to Spec G, use only no. 22 nuts on the engine housing.
5. Failure to center the starter properly will damage the starter. Distortion or shifting of the blower housing on the engine may cause incorrect alignment. Place the starter against the engine blower housing and be sure the centering pin, no. 19, engages the center hole of the cup and flywheel mounting capscrew while the starter mounting holes align.

If the centering pin does not extend a sufficient length to engage the center hole of the capscrew, use a pair of pliers to pull the pin out farther.

Use toothed washers and screws no. 21 to mount the starter securely to the blower housing.

6. Operate the starter to see that the installation is satisfactory. After the starter is mounted on the engine, there should be clearance of approximately 1/8 inch (3 mm) between cup no. 2 and rotor face no. 17. Maintain a minimum clearance of 3/32 inch (2 mm) between capscrew no. 23 and starter shaft.
7. During operation, the starter friction shoe plates roughs the cup. This condition is normal.
8. When operating the starter, slowly pull out at least six inches (153 mm) of cord, then give a fast steady pull. By this method, cord is less apt to break due to a false start and engine backfiring.

Starter Disassembly:

WARNING

Improper disassembly may cause rewind spring to release wildly and cause personal injury.

1. Avoid losing spring no. 8 by holding washer no. 7 in position with hand while removing triangular retainer ring no. 6 with a screwdriver (Figure 18-1).
2. Remove the following parts and assembly: Large washer no. 7, brake spring no. 8, washers no. 9 and 10, friction shoe assembly (including parts no. 11, 12, 13 and 14).
3. To prevent spring rotation of rotor (rope sheave) no. 17, hold cord as shown in Figure 18-1 while

removing four screws. Continue to hold rotor and cover as shown and remove mounting ring no. 3 and middle flange no. 5. Now relieve the tension of the rewind spring by slowly releasing hold and allowing spring to unwind.

4. Prevent rewind spring no. 18 from escaping from cover (and causing personal injury) by carefully lifting rotor no. 17 only 1/4 inch (6 mm) away from the cover and detach inside spring loop from rotor (Figure 18-1).

If spring should escape, replace it in the cover easily by coiling the spring in turns.

5. Clean the starter parts. Gummy grease and dirt may cause sluggish performance.

Cord Replacement:

1. First perform procedure given for starter disassembly.
2. Tie single knot in end of new cord (Figure 18-1).
3. Thread cord through rotor hole and out through rotor cord groove, pulling knot into cavity. Then wind rope on rotor. Replace handle, tying a double knot.
4. Perform procedure given for starter assembly.

Rewind Spring Replacement:

1. First perform procedure given for starter disassembly.
2. Starting with the inside loop, remove rewind spring no. 18 carefully from cover no. 20 by pulling out one loop at a time, holding back rest of turns.

The spring must be wound in crankshaft rotation direction starting from the outermost coil of the spring.

3. Spring holders furnished with replacement springs simplify the assembly procedure. Place spring in proper position as shown in Figure 18-1, with the outside loop engaged around the pin. Then press spring into cover cavity, thus releasing the spring holder.
4. Lubricate the shaft with a film of light grease. Lubricate the rewind spring with a few drops of SAE20 or SAE30 oil. Under extremely dusty operating conditions, if performance indicates a dirty condition, then use only powdered lubricating graphite on the spring or do not lubricate it at all. Avoid lubrication of the brake washers.
5. Perform procedure given for starter assembly.

Starter Assembly:

1. First complete installation of rewind spring and cord.
2. Place rotor no. 17 (complete with handle and cord wound in proper direction) into cover no. 20 and hook the inside loop of spring no. 18 to rotor with the aid of a screwdriver or other slender tool. Prevent the unhooking of the rewind spring from

PARTS SEQUENCE

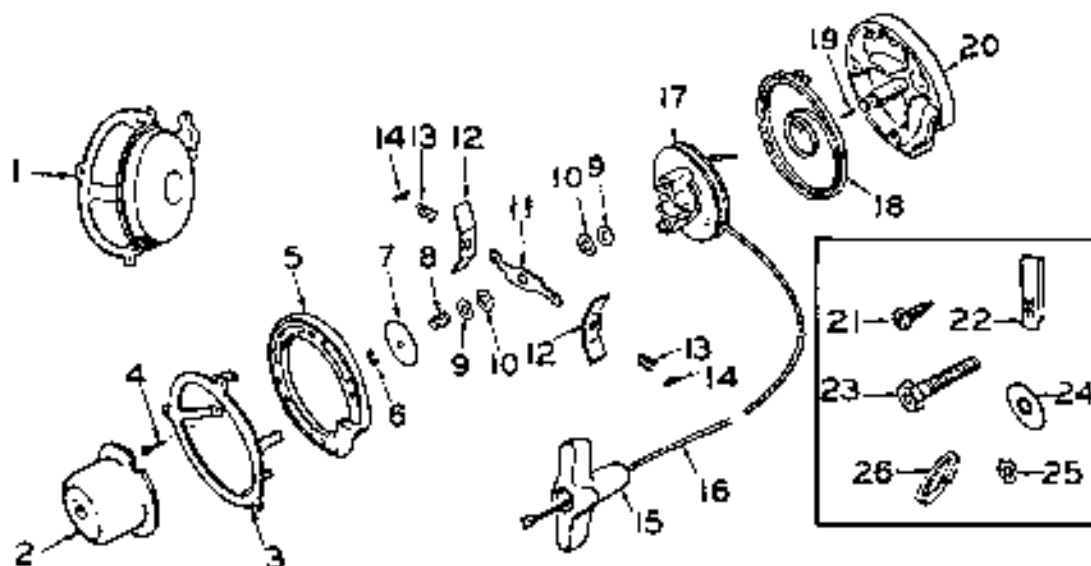

SECURE CUP

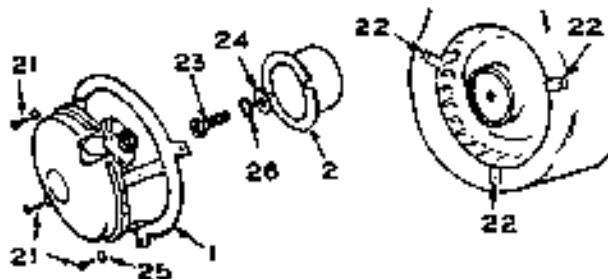

AVOIDING SPRING LOSS

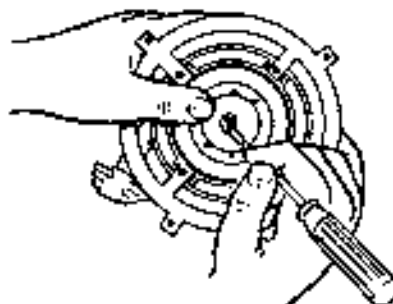

PREVENT SPRING ROTATION

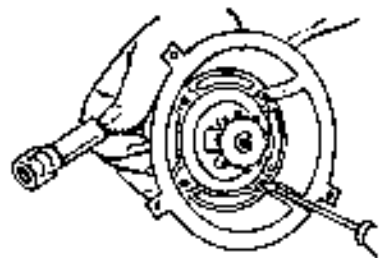

LIFTING ROTOR



SINGLE KNOT
DOUBLE KNOT



SPRING POSITIONING

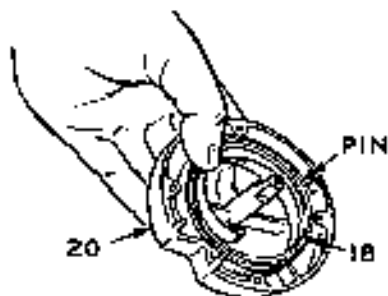

SHARP EDGE

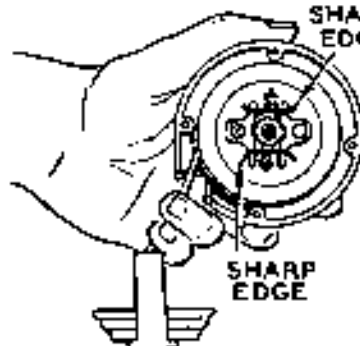

SHARP EDGE

FIGURE 18-1. SERVICING THE RECOIL STARTER

the rotor by keeping slight tension on the spring until later, when the middle flange is installed.

3. Install the following parts and assembly: Washers no. 9 and 10, friction shoe assembly (see Figure 18-1 for positions) (including parts no. 11, 12, 13 and 14), spring no. 8, farger washers no. 7 and truarc retainer ring no. 6.
4. Wind the cord in the proper direction onto the rotor, then add two additional turns of the rotor and cord for proper tension. A fatigued spring condition may require more additional turns to attain desired tension of the rewind spring.
5. With tension held on the cord, place middle flange no. 5 against cover no. 20, then install mounting ring no. 3 in position for desired direction of pull and continue as instructed under starter installation.

Troubleshooting: If friction shoe fails to function and engage with the cup, check for failure of brake spring no. 8. Check for lubrication getting onto brake washers no. 10 and check for proper position of friction shoe sharp edge and friction shoe lever.

Periodically, observe if starter assembly has shifted away from centering with crankshaft.

A broken rewind spring should be replaced with a new one.

Extend the life of a fatigued rewind spring by adding turns of the rotor to increase tension and then reinstalling the middle flange. Or, try forming new loops and coiling spring inside-out.

LK, CCK, NB, NH MANUAL STARTERS

Readi-Pull Starter: Refer to Figure 18-2 showing the manual starter disassembled.

WARNING The recoil spring may unwind and cause injury if allowed to release wildly when starter is disassembled or assembled.

The sheave hub bearing (16) has a recess that was packed full of grease at the factory. Normally, no additional lubrication is required. However, if the starter is disassembled for some other reason, add grease to the bearing and to the spring pawls (11) where they contact the ratchet arm (13).

To install a new rope or internal parts, remove the starter from its mounting ring by removing the four clamping screws.

To install a new rope, rotate the sheave (10) with crankshaft rotation direction to fully tighten the spring (8). Back up only as necessary to align the hole in the sheave with the slot in the cover (5). Clamp the rope to the sheave. When released, the rope will wind on the sheave.

To install a new recoil spring:

1. Remove the sheave from the cover.
2. Wind the spring, with its rivet heads outward, forming a coil small enough to be inserted in the recess of the starter cover. It may be necessary to tie the spring with a piece of wire to prevent its unwinding during installation.
3. Place the spring in the cover recess in crankshaft rotation direction.
4. Remove the tying wire if used.
5. While holding the spring to prevent its unwinding, install the inside end of the spring on the roll pin (7) in the cover.
6. With the pull rope removed, install the sheave assembly in the cover so that the tab on the sheave enters the outside end loop of the recoil spring. Be sure the thrust washer (9) is in place.
7. Then install the pull rope.

Spring breakage is much less common than spring fatigue due to long usage. In either case, replace the spring. Cleaning and lubricating the pawls and ratchet arms in the rope sheave improves a sluggish

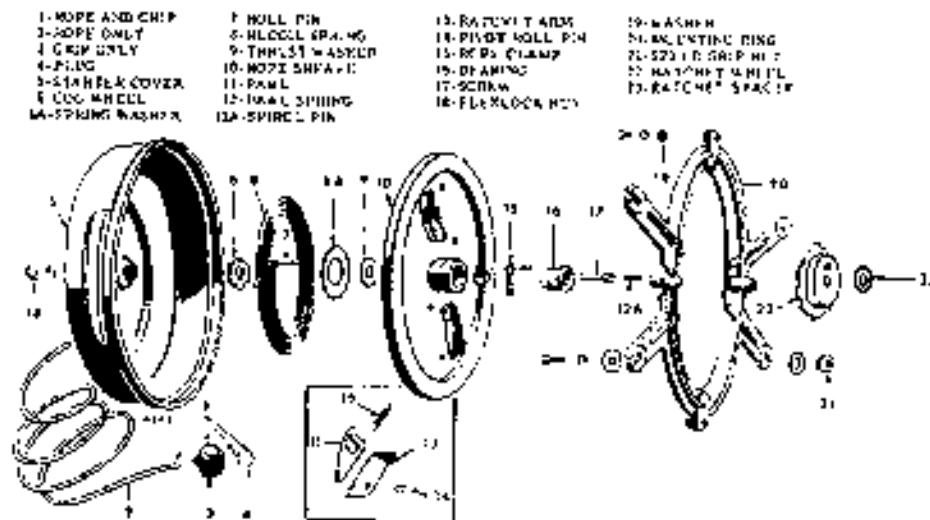

FIGURE 18-2. READI-PULL STARTER

acting recoil. To temporarily extend the life of a fatigued spring, try rewinding it *inside out* (rivet heads inward).

To install a ratchet arm (13) in the sheave, first remove the pawl (11). The ratchet arm fits in only the correct position. Install the spring pawl with its flat edge against the ratchet arm.

The anti-back lash cogwheel (6) is an easy press fit on the starter cover.

Installing the CCK Starter Units Prior to Spec D: Refer to Figure 18-3. The blower housing on the engine must be as rigid as possible. Examine the blower housing carefully. If the mounting holes are worn or if the blower housing is otherwise damaged, replace it with a new one. Proceed as follows to install the complete starter kit:

1. Refer to the installation drawing. Do not change the flywheel mounting screw. New screws (if

furnished) are needed on other model engines only.

2. Install the new ratchet wheel (1) to the blower wheel, using the two special head screws and lock washers provided. A 3/8-inch, 12-point socket or closed end wrench fits these screws. Tighten securely.
3. Four special nuts are supplied for mounting the starter to the blower housing. If the blower housing is not already fitted with similar mounting nuts, remove the blower housing and install the nuts in the square holes (2) in the blower housing. Reinstall the blower housing, tightening securely in place.
4. Note the two small holes drilled through the starter cover. Pull out slowly on the starter rope while sighting through one of these holes. When the starter is turned a partial turn, the open-center roll pins in the starter rope sheave aligns with these two holes. While holding in the aligned position, insert a ten penny common nail through

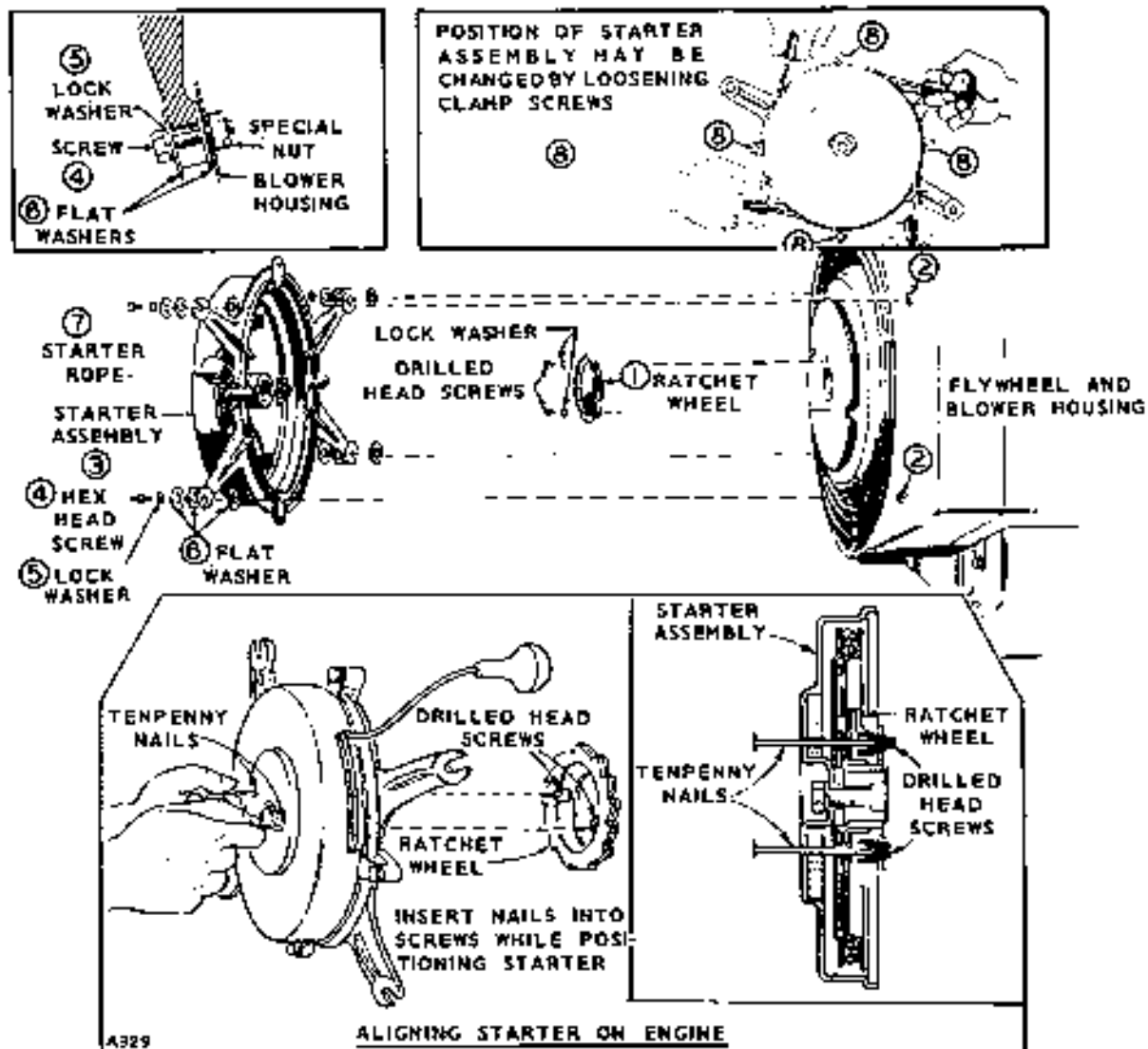

FIGURE 18-3. INSTALLING STARTER ON ENGINE (PRIOR SPEC D)

Rev 10-75

each of the holes. Push the nails in up to their heads.

5. Install the starter assembly (3) to the blower housing, making sure that the nail ends enter the pilot holes in the ratchet wheel mounting screws. It will probably be necessary to turn the flywheel a partial revolution to allow proper alignment. While holding in position, mount the starter, using a hex head screw (4), lock washer (5) and two flat washers (6) at each mounting arm (Figure 18-3). Tighten the mounting screws securely. Remove the nails.
6. The direction of pull on the starter rope is adjustable to fit the requirements of the individual installation. See detail B. To change the direction of pull, loosen the four clamp screws (8) and turn the starter in its mounting ring to the desired position. Tighten the four clamp screws securely. Try the starter several times, making sure that the pull rope will not rub against one of the clamp screws.
7. Occasionally, check the operation of the starter, making sure the starter is properly centered (step 5 above). See that the blower housing mounting screws are tight. If the blower housing tends to shift, its mounting holes may have become worn or oversize. If the blower housing tends to weave or distort during starter operation, installation of a new housing is recommended.

Installing the Readi-Pull Starter CCK Units, Spec D and Later, LK, NB and NH Units: See that the engine blower housing is in good condition. If the mounting holes are worn or if the blower housing is otherwise damaged, replace it with a new one. Refer to Figure 18-4.

1. Install the new ratchet wheel (1) against rope sheave (11), using lock washer (10) and flywheel mounting screw (9). Discard the large flat washer from engines so equipped. Engage drive hole with flywheel boss.
2. Four special nuts are supplied for mounting the starter to the blower housing. If the blower housing is not already fitted with similar nuts, remove the blower housing and install the nuts as shown in detail A. Reinstall the blower housing, lightening securely in place.
3. Install centering pin (12) in starter center screw (14) allowing 3/8 inch (10 mm) to protrude. For reinstallation, adjust pin depth.
4. Center the starter assembly over the ratchet wheel with the centering pin engaging the center hole of the flywheel mounting screw. While holding in position, mount the starter, using a hex head screw, lock washer and two flat washers at each mounting arm as shown in detail A. Tighten the mounting screws securely.
5. The direction of pull on the starter rope is adjustable to fit the requirements of the individual

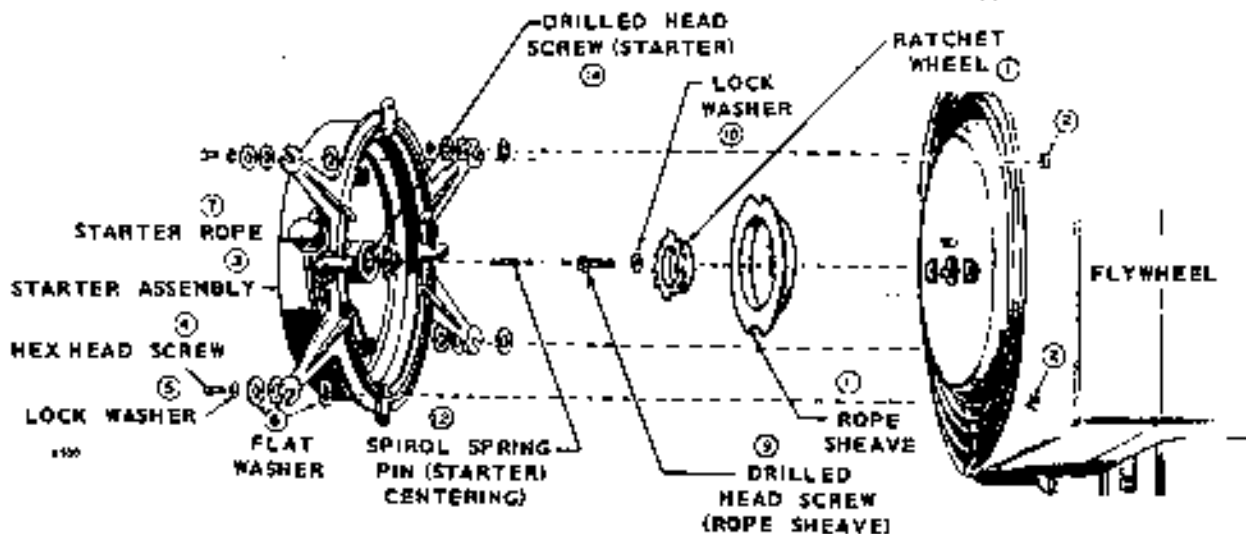
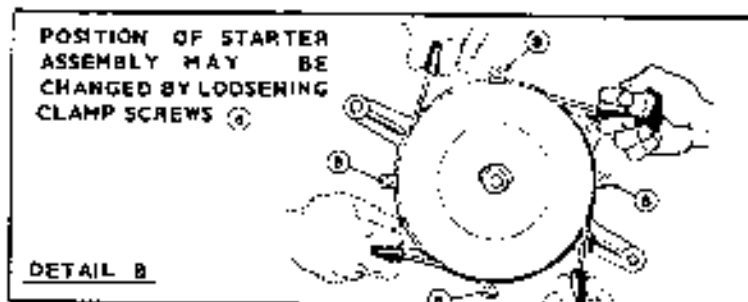
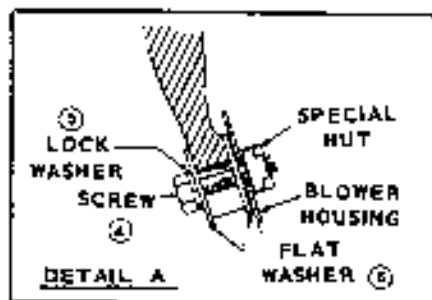

FIGURE 18-4. INSTALLING STARTER KIT (SPEC D AND LATER)

installation. See detail B. To change the direction of pull, loosen the four clamp screws (3) and turn the starter in its mounting ring to the desired position. Tighten the four clamp screws securely. Try the starter several times, making sure the pull rope does not rub against the clamping screws.

protects the starter from damage before it can be disengaged from the flywheel

CAUTION If the starter button is held down too long after the engine starts, the over-running clutch will burn up, causing severe damage to the starter motor.

The bendix drive starting system is mounted on a shaft that extends from the starter motor. This shaft has spiral threads that match similar threads located on the inside of the bendix pinion (Figure 18-6). The threaded bendix screw shaft is flexibly driven by a heavy spiral spring. When the starter motor is not operating, the bendix pinion is retracted so the bendix drive clears the flywheel ring gear. When the starter button is pressed activating the starter motor, the starter shaft and bendix pick up speed rapidly. The internally threaded bendix pinion, being a loose fit on the threaded sleeve, lags behind and does not pick up speed as rapidly as the sleeve, but instead moves axially, influenced by the sleeve threads. This axial movement engages the drive pinion with the flywheel ring gear and starts to crank the engine. The drive pinion and ring gear teeth are beveled on the ends to assure their engaging properly. The spiral spring on

AUTOMOTIVE TYPE ELECTRIC STARTING

Onan industrial engines and generating sets using revolving field generators are equipped with automotive type electric starters. Two types of electric starters are used—the solenoid engaged starter and the bendix engaged starter.

The solenoid engaged starter is shown in Figure 18-5. When the starter button is pushed, battery current energizes the start solenoid, causing it to pull its core in. This causes an arm on the starter to shift the starter pinion into engagement with the flywheel ring gear. At the same time, the contacts in the solenoid close allowing the starter motor to turn. With this starting system, the starter motor remains engaged until the starter button is released. An over-running clutch

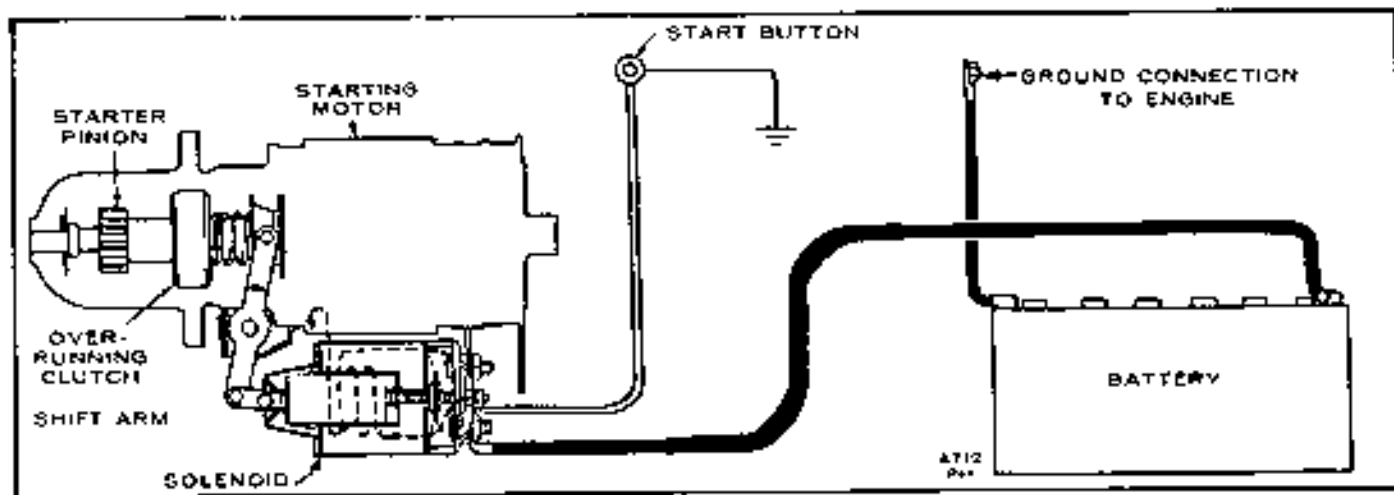

FIGURE 18-5. SOLENOID SHIFT STARTER

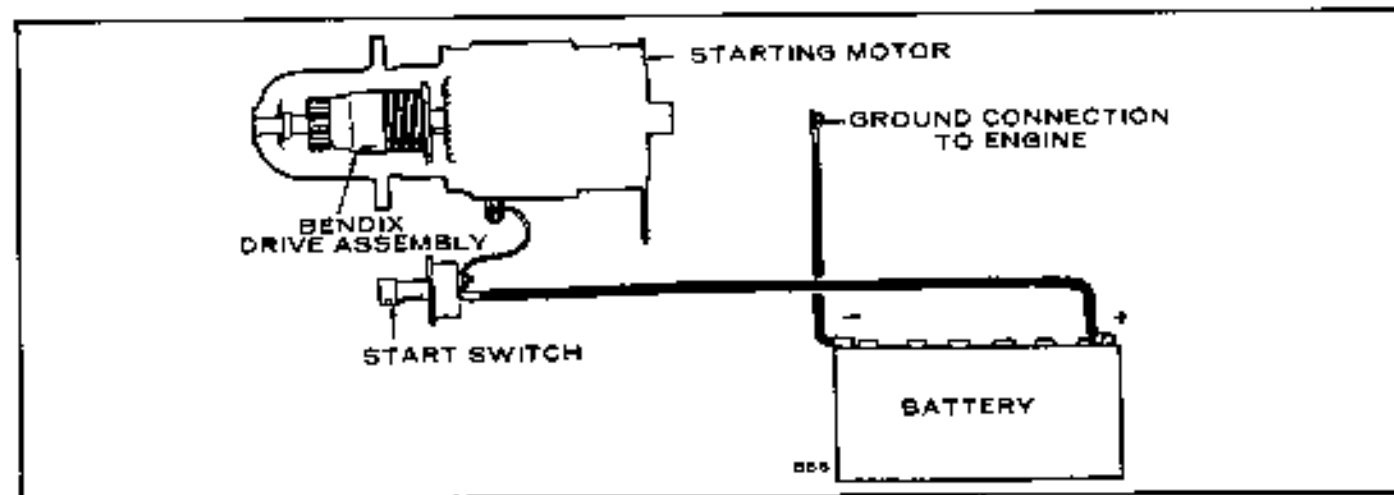

FIGURE 18-6. BENDIX TYPE STARTER

Rev 10-75

the bendix absorbs the shock of picking up the cranking load. As the engine starts and picks up speed, the process is reversed. The bendix pinion is kicked out of engagement with the flywheel ring gear. The ring gear accelerates the pinion beyond the speed of the starter and forces the pinion out of mesh with the ring gear.

TROUBLESHOOTING AND MAINTENANCE OF AUTOMOTIVE TYPE STARTING SYSTEMS

Cranking Motor: For proper cranking motor operation with a minimum of trouble, follow a periodic maintenance procedure. Periodic lubrication, inspection of the brushes and commutator as described in this section ensures long cranking motor life. Periodic disassembly of the cranking motor for a thorough overhaul is recommended as a safeguard against accumulations of dust, grease and parts wear.

Lubricate all bearings with 8 to 10 drops of light engine oil (SAE #20). Lubricate the cranking motor drives with a few drops of light engine oil.

CAUTION Never oil the commutator. Oil on the commutator reduces the cranking ability of the motor.

Keep the commutator clean by using No. 240 sandpaper. Never use emery cloth.

If the commutator is out-of-round or has high mica, remove it from the cranking motor. Turn the commutator down on a lathe, being careful to remove only enough material to true up the commutator and remove high mica.

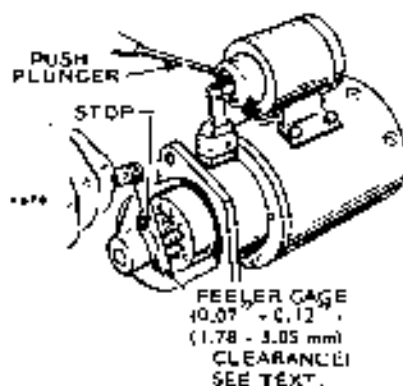

Replace worn brushes. If brushes wear rapidly, check for excessive brush spring tension and roughness or high mica on the commutator.

Solenoid Shift: Periodically inspect solenoid and shift lever for proper operation. Keep the solenoid shift lever free of dirt and excess grease.

The over-running clutch is packed in a special high melting point grease and after its initial assembly, needs no further lubrication. This clutch prevents the engine from turning the starter motor at too high a speed, once it is started.

CAUTION Do not subject the over-running clutch to grease dissolving or high temperature cleaning methods. This may cause the clutch to lose some or all of its grease.

If the pinion does not turn freely in the clutch in the over-running direction, or the clutch tends to slip in the opposite direction, replace the assembly. A worn clutch indicated by excessive looseness of the pinion requires replacement.

Never attempt to repair or relubricate a defective clutch.

The clearance between the pinion and the housing should be approximately 1/8 inch (3 mm) when the pinion is in the operating position.

Testing Solenoid Shift Starter Cranking

Bendix Drive: The teeth of the bendix pinion are chamfered on only one side and specially rounded and polished to make the automatic meshing with the flywheel ring gear more efficient. The bendix is designed so if the ends of the pinion teeth meet end to

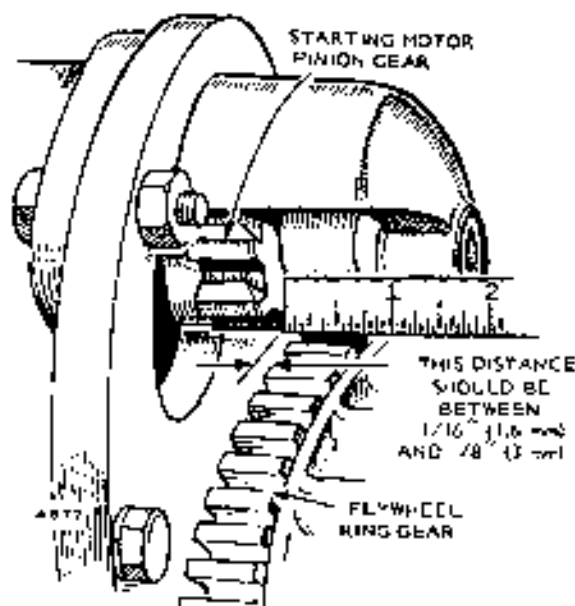

FIGURE 18-7. PINION CLEARANCE

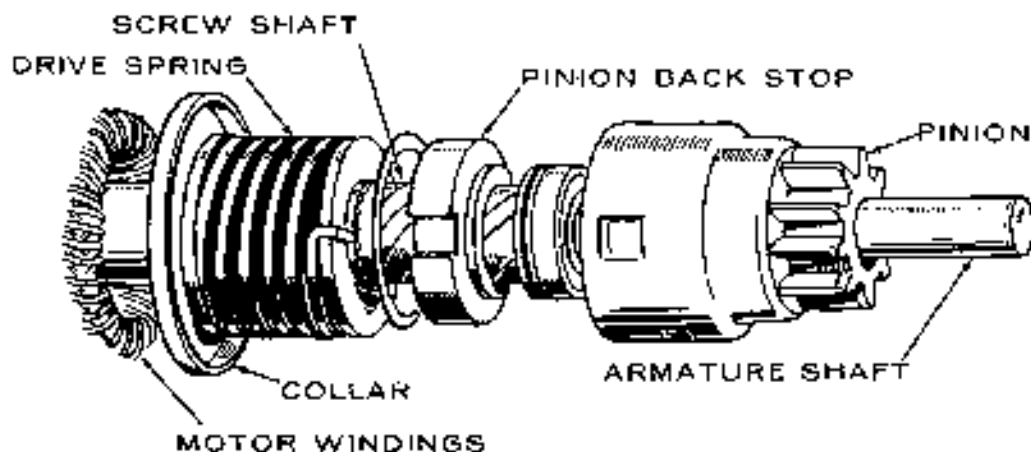

FIGURE 18-8. BENDIX ASSEMBLY

end with the ring gear teeth, and, keeping in mind that the threaded screw shaft is freely mounted on the bendix drive shaft, the bendix assembly can move back slightly against the pressure of the driving spring.

The longitudinal movement of the screw shaft permits the pinion to turn slightly farther and enter the flywheel ring gear.

Use the correct length of drive spring when making replacements. The length of the drive spring controls the longitudinal movement of the bendix pinion (meshing and unmeshing of the pinion and flywheel ring gear).

Keep the bendix drive shaft free of rust, burrs or bends so the screw shaft can move freely along it. A damaged bendix pinion necessitates the replacement of the assembly. Lubricate the threads of the screw shaft with SAE #10 engine oil.

Onan recommends replacement of faulty bendix drive units and provides no further service information concerning their repair. For further bendix repair information, contact the manufacturer of your starter motor.

REPAIR OF STARTING UNIT

CAUTION Never use steam or high pressure water to clean starting units while on or off the engine or damage to the component will occur.

Disassembly

1. Remove all wires to the starting unit. Tag each wire so that it can be reinstalled in its original position.
2. Remove the solenoid.

The solenoid spacers are mounted with the steel spacer toward the bracket (Figure 18-9).

3. Remove the starter motor thru-bolts and divide the starter into three main assemblies—the front bracket, the housing and the rear bracket. Some bendix model starters use short screws to hold the three starter sections together (Figure 18-9). The spacing washers shown on the solenoid starter in Figure 18-9 are used for adjustment of the thrust gap of the armature shaft and are located between the rear bracket and the commutator shaft.

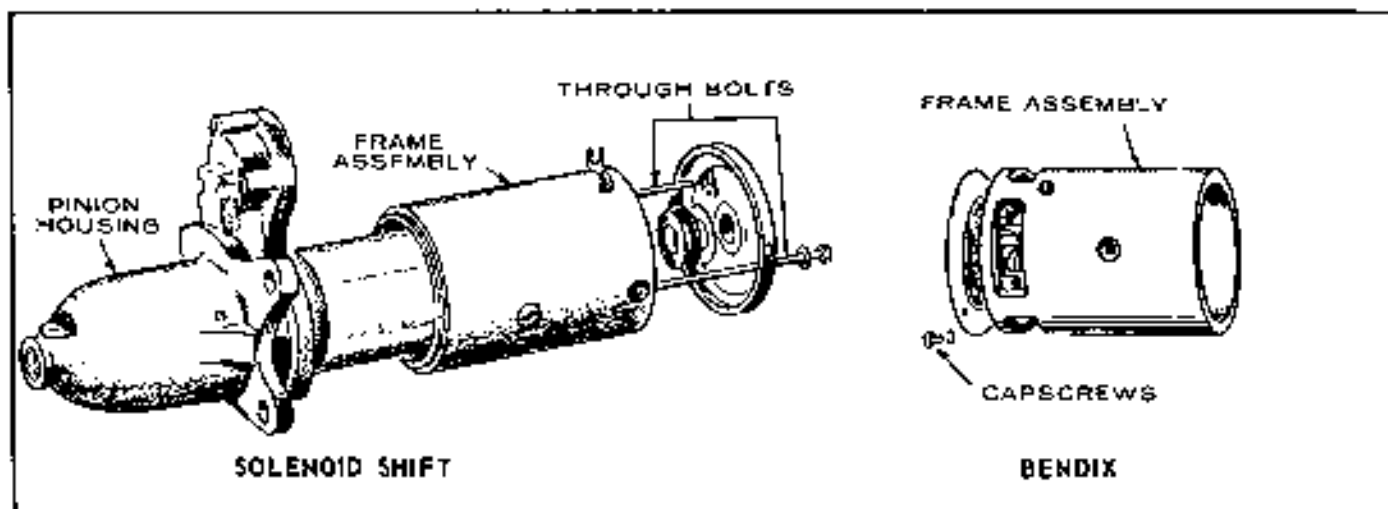

FIGURE 18-9. REMOVING THROUGH BOLTS

Rev 10-75

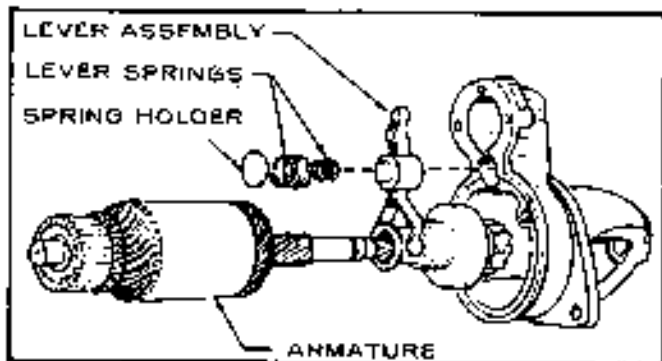

FIGURE 18-10. REMOVING THE ARMATURE

On the solenoid shift models, the steel spacing washer is on the commutator side.

- 4 On the solenoid shift units remove the armature from the front bracket. Be careful not to miss the small steel washer used in the end of the armature shaft. Remove the shift lever at the same time the armature is removed. Remove the spring holder, lever springs and retainer prior to the lever (Figure 18-10).
- 5 On the bendix drive starters, the entire assembly mounts on the armature shaft (Figure 18-11). When disassembling the bendix starter, pay particular attention to the various parts and their positioning in the starter assembly. If the gears of the bendix pinion are damaged, replace the entire pinion. Inspect the screw shaft for rust and burrs.
- 6 On solenoid shift models, remove the ring after driving the pinion stopper toward the pinion gear using a cylindrical tool (Figure 18-12). Remove the overrunning clutch and the pinion stopper at the same time.
- 7 Remove the brushes from the brushholder and inspect them. Replace brushes that are worn to one half of their original size. Remove the brush springs from the holder and examine them. Replace brush springs that appear abnormally weak (Figure 18-13).
8. Remove the pole shoes if necessary by removing the flathead machine screws that anchor them to the frame

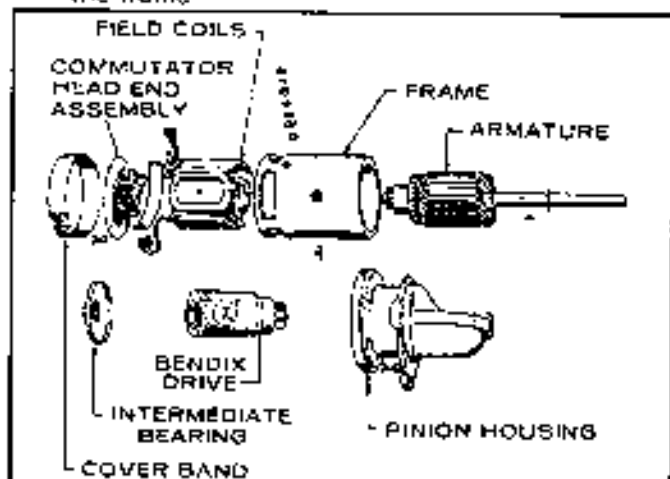

FIGURE 18-11. BENDIX DRIVE STARTER

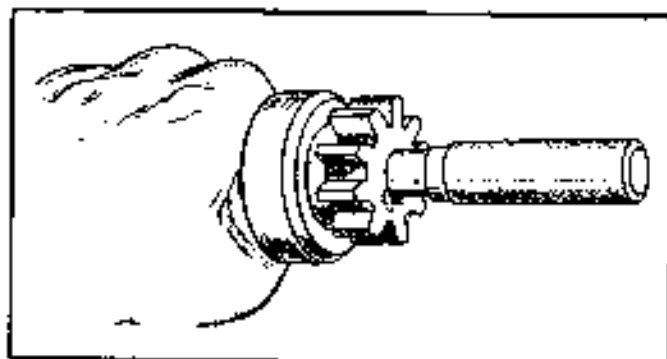

FIGURE 18-12. REMOVAL OF RING

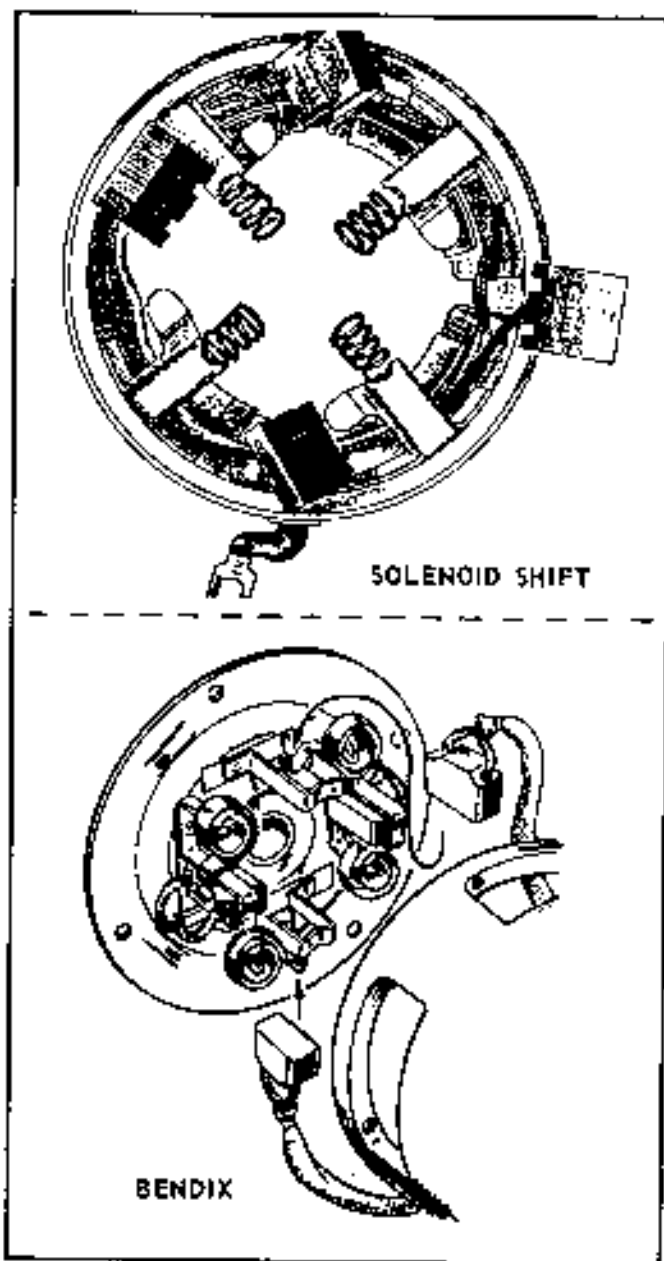

FIGURE 18-13. BRUSHES

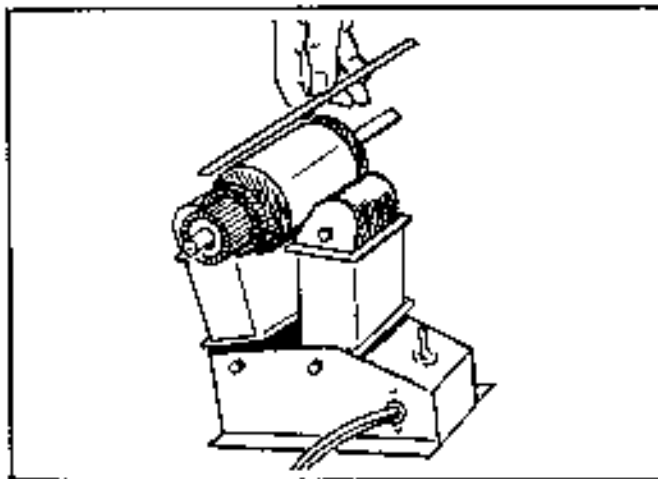

FIGURE 18-14. ARMATURE SHORT CIRCUIT TEST

INSPECTION OF PARTS

Testing the Armature for Shorts: Place the armature in the growler and hold a thin steel blade parallel to the core and just above it, while slowly rotating the armature in the growler (Figure 18-14). A shorted armature causes the blade to vibrate and move toward the core. Replace a shorted armature.

Testing the Armature for Grounds: Touch the armature shaft or core and the end of each commutator bar with a pair of ohmmeter leads (Figure 18-15). If the ohmmeter reading is low, it indicates a grounded armature. Replace the armature.

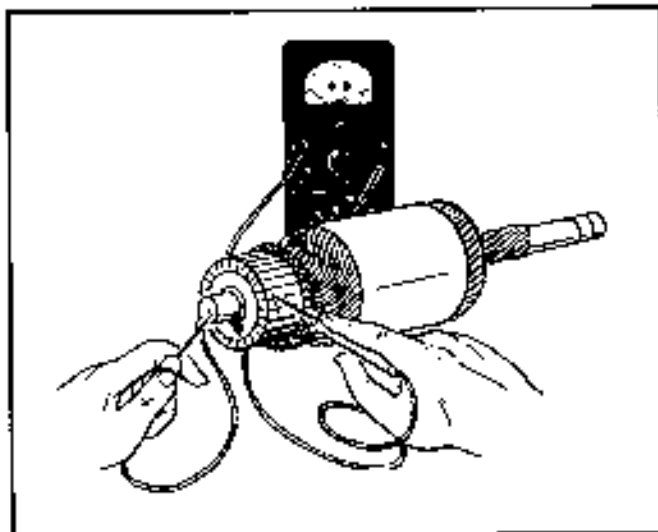

FIGURE 18-15. ARMATURE GROUND TEST

Testing the Armature for Open Circuit: The most common place for an open circuit to occur is at the commutator riser bars. Inspect the points where the conductors are joined to the commutator bars for loose connections.

Testing Commutator Runout: Place the commutator in a test bench and check runout with a dial indicator (Figure 18-16). When commutator runout exceeds .004 inch (.102 mm), reface the commutator

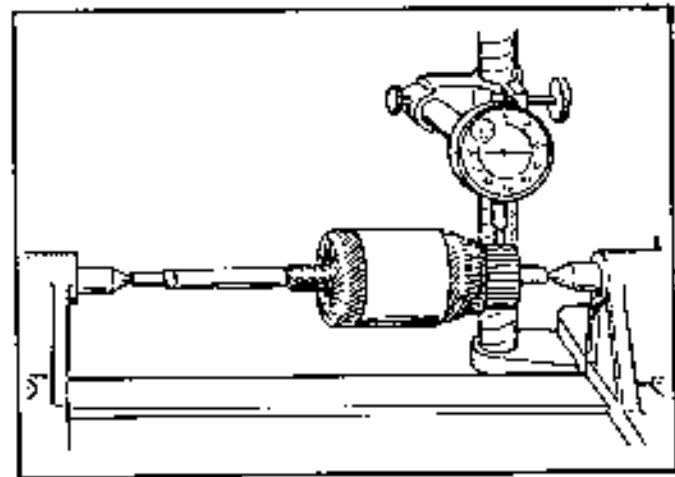

FIGURE 18-16. CHECKING COMMUTATOR RUNOUT

Testing Armature Shaft Runout: Check the armature shaft as well as the commutator. Straightening a bent armature is possible, but if the shaft is worn, a new armature is required (Figure 18-17).

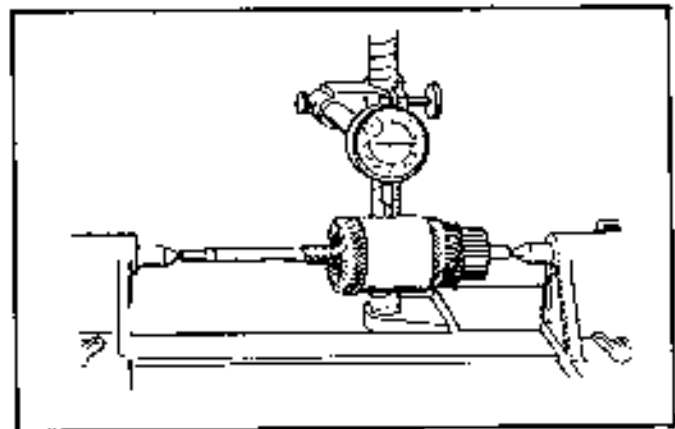

FIGURE 18-17. CHECKING ARMATURE SHAFT RUNOUT

Testing Field Coils for Grounds: Place one lead on the connector and the other on a clean spot on the frame after unsoldering shunt field coil wire. If the ohmmeter reading is low, the fields are grounded either at the connector or in the windings (Figure 18-18).

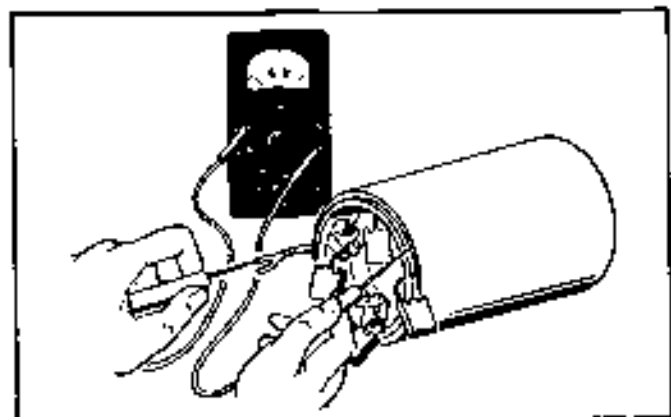

FIGURE 18-18. FIELD COIL GROUND TEST

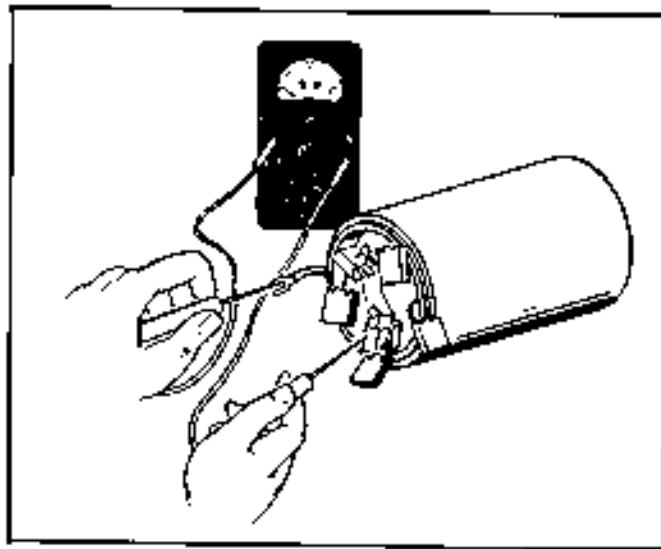

FIGURE 18-19. FIELD COIL OPEN CIRCUIT TEST

Testing Field Coils for Open Circuit: Place one lead on the connector and the other on a clean spot on the brushholder (Figure 18-19). If the ohmmeter reading is high, the field coil is open. Check all four brushholders in the same manner.

Inspection of Brushes: When brushes are worn more than .3 inch (7.6 mm), replace them. Figure 18-20 shows the wear limit. See that the brushes move smoothly in the brushholders.

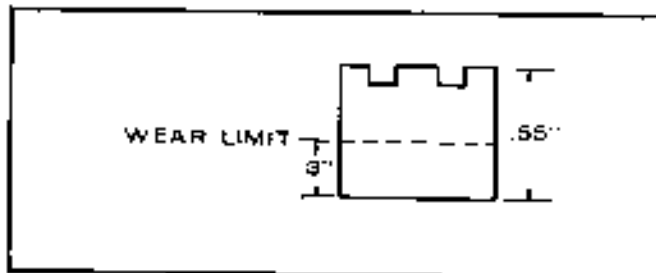

FIGURE 18-20. BRUSH WEAR LIMIT

Inspection for Brush Spring Tension: Measure brush spring tension with a tension meter (Figure 18-21). Push the brush into its holder and take the reading just as the brush slightly projects from the brushholder. On a new brush the spring tension should measure 29 to 38 ounces (822 to 1077 g).

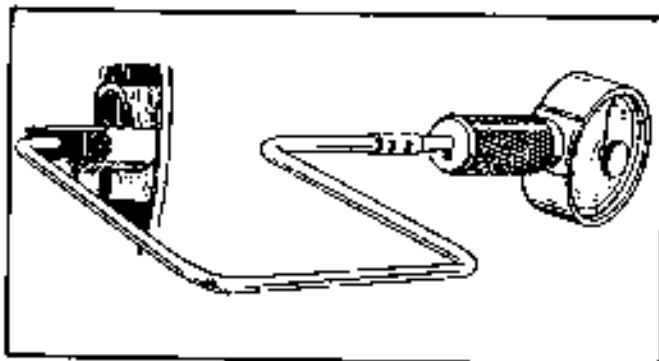

FIGURE 18-21. BRUSH SPRING TENSION TEST

Assembly: Inspect the parts in accordance with the procedure described in *Inspection of Parts*. Make the necessary repairs. Reassembly is the reverse of the disassembly procedure. Take the following precautions:

1. Clean all the parts carefully with a dry cloth and compressed air if available.

CAUTION Do not immerse bearing equipped parts in cleaning fluid. Clean them with a brush dipped in mineral spirits. Do not immerse the overrunning clutch in cleaning solvent. Thoroughly dry all parts that have come in contact with cleaning solvent.

2. Apply 20 weight oil to the armature shaft and splines. Apply grease (Shell Albania No. 2 or equivalent) sparingly on the shift lever pin, the joint of the shift lever and plunger, the plunger and spacing washers at the end of the shaft.
3. To mount the overrunning clutch, insert the pinion stopper into the armature shaft and apply the ring rigidly to the groove of the shaft. For insertion of the ring, use the tool shown in Figure 18-22 and pull the pinion stopper up.

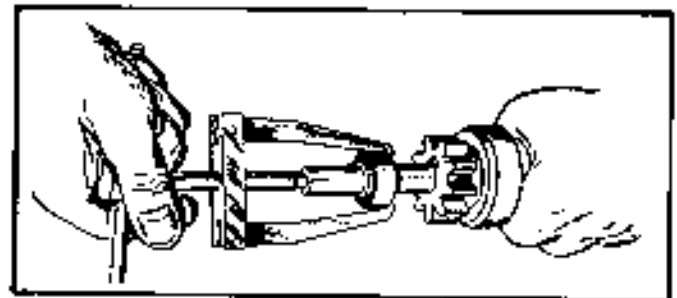

FIGURE 18-22. MOUNTING OVERRUNNING CLUTCH

4. Use spacing washers to adjust the armature so an end play of .004 inch to .020 inch (.102 to .508 mm) exists.
5. Tighten the thru-bolts on the solenoid shift starters to a torque of 35 to 44 foot pounds (47 to 60 N•m).

Inspection After Overhaul:

1. For no load test, wire the starting motor as shown in Figure 18-23. With the motor running the meter readings should be as follows.

Speed 3700 rpm minimum
Voltage 11.5 volts
Current Draw 60 amp maximum

The wire for the above test should be at least 14 gauge and as short as possible. If anything is wrong in the test, check the following items:

- Annealed brush springs
- Improperly seated brushes
- Insufficient armature endplay
- Shorted, open or grounded armature
- Grounded or open field coil
- Poor electrical connections
- Dirty commutator

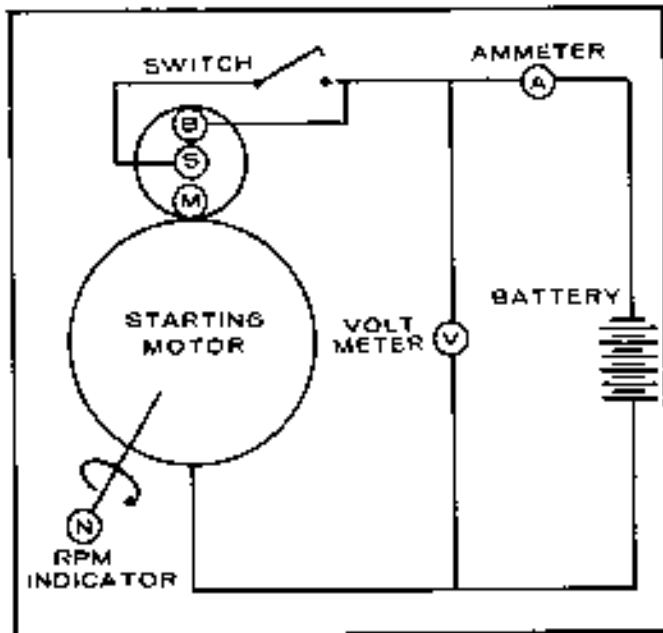

FIGURE 18-23. NO LOAD TEST WIRING

2. **Adjusting Pinion Clearance:** Connect the battery to the starting motor (Figure 18-24). This allows the starter motor pinion to slide and stop. Measure the clearance between the end of the pinion and pinion stopper when the pinion is pushed lightly toward the commutator end. The clearance should be .02 inch to .06 inch (508 to 1.524 mm). Adjust for proper clearance by removing the magnetic switch attaching screws and select the proper thickness of fiber packings (Figure 18-25).

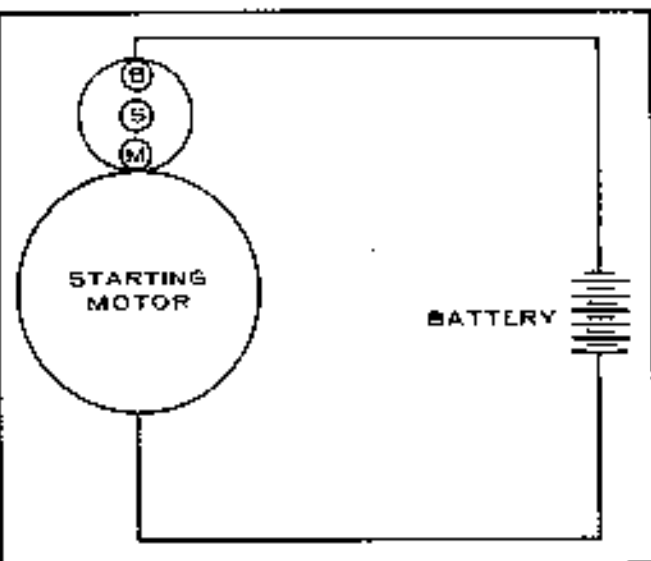

FIGURE 18-24. BATTERY CONNECTIONS

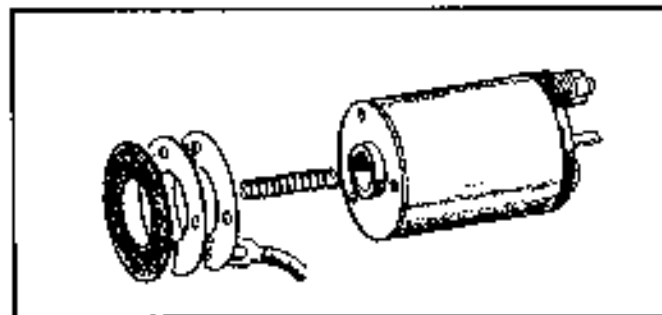

FIGURE 18-25. ADJUSTING PINION CLEARANCE

EXCITER CRANKING

Onan electric generating plants with revolving armature generators use the generator as a starting motor for the engine. The battery supplies the starting current through a series field winding and the DC section of the armature (Figure 18-26).

CAUTION Poor starter performance may damage the generator. If the starter does not crank over the engine compression stroke, high currents passing through the armature may burn out the commutator.

Keep the battery, cables and generator in good operating condition

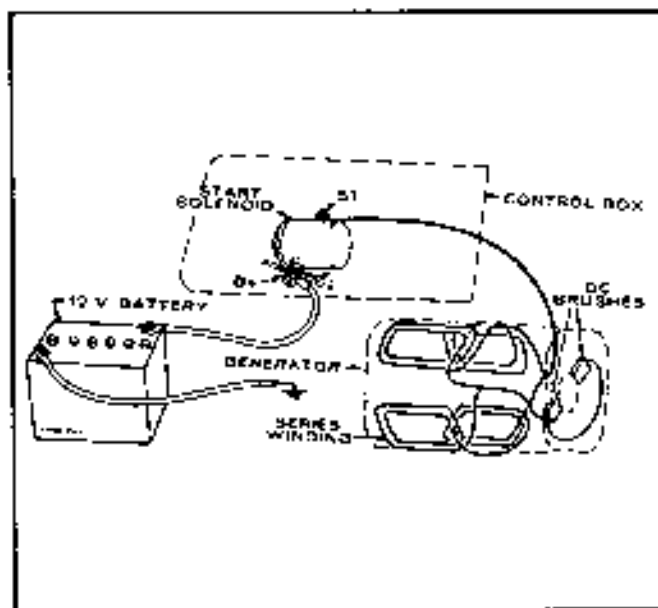

FIGURE 18-26. EXCITER CRANKING

BF, NH POWER DRAWER UNITS

Starter Removal

Starter removal requires removal of the generator set from its slide rails and mounts.

1. Remove blower scroll from front of engine (four screws).

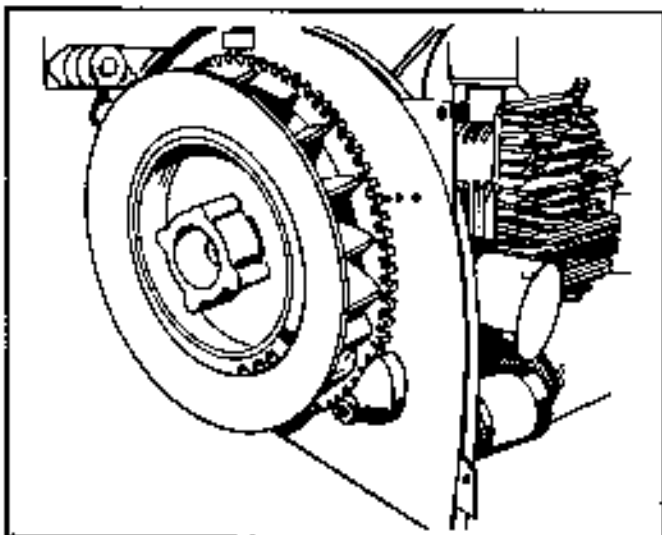

FIGURE 18-27. BLOWER SCROLL REMOVED

2. Remove flywheel with a flywheel puller or loosen center cap screw and direct a sharp blow to loosen. It helps to pull forward on one side of flywheel when striking with a hammer. If using this procedure be sure to leave center cap screw loosely in place or blower wheel will fall on floor.
3. Remove left and right hand air shrouds that cover cylinder heads.
4. Remove exhaust manifold.
5. Remove blower scroll backing plate (two screws on bottom—two on gear cover).

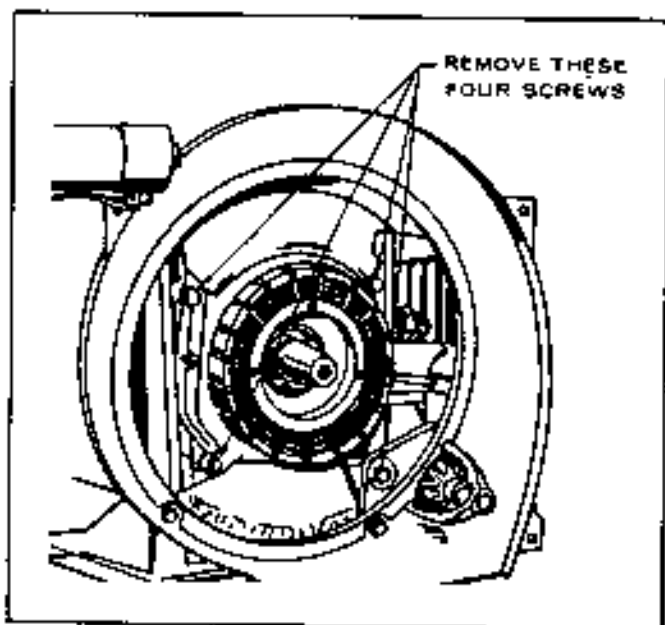

FIGURE 18-28. REMOVING BACKING PLATE

6. Disconnect heavy wire that connects to starter.
7. Remove two starter hold-down studs and lift out starter.

Starter Disassembly

Disassemble the starter as follows:

1. Loosen the nut that attaches the solenoid motor terminal to the field coil connector lead and take off the connector lead

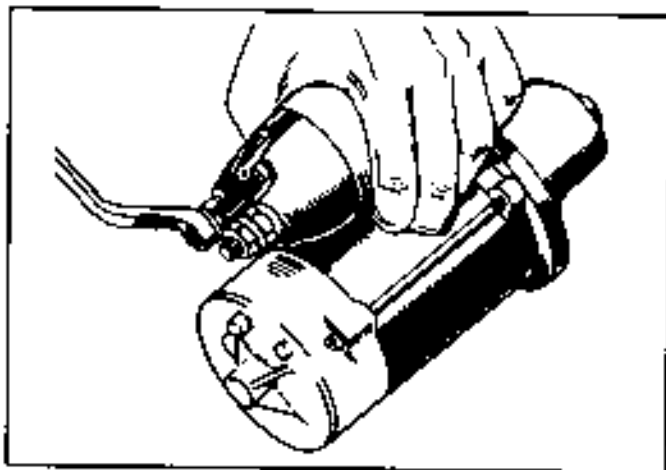

FIGURE 18-29. CONNECTOR LEAD REMOVAL

2. Loosen the retaining screws and remove the solenoid from the front bracket. Simultaneously, the fibre washers, the return spring and the solenoid plunger are removed.

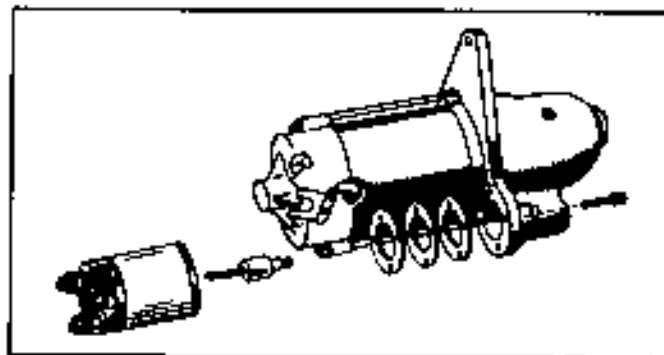

FIGURE 18-30. SOLENOID REMOVAL

3. Unscrew the through bolts and separate the yoke with the rear bracket from the front bracket.

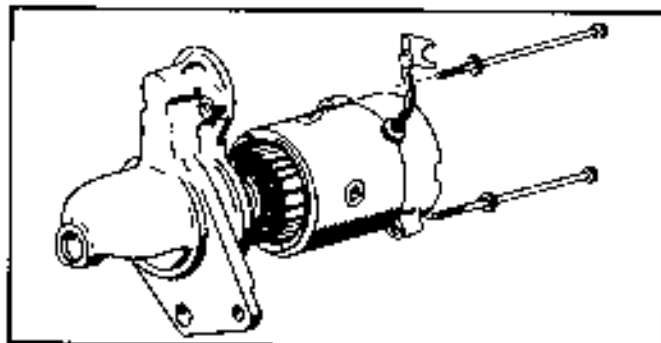

FIGURE 18-31. YOKE SEPARATION

Rev 10-75

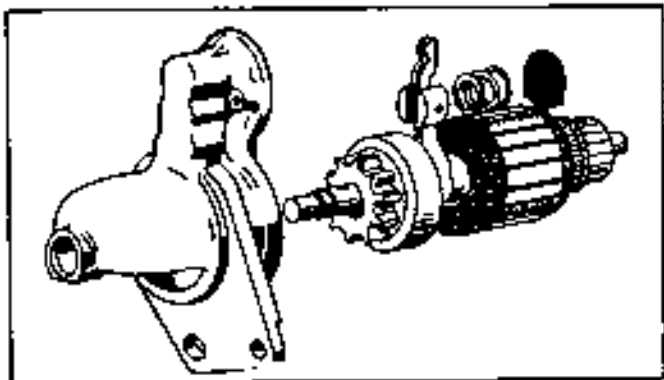

FIGURE 18-32. ARMATURE REMOVAL

4. Remove the armature from the front bracket. Simultaneously, the shift lever, the lever spring and the spring holder are removed.

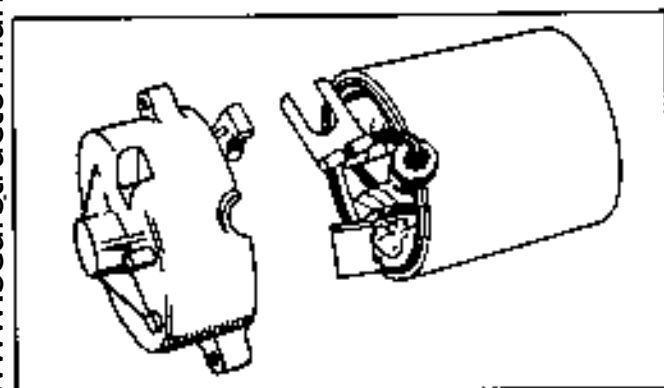

FIGURE 18-33. REMOVAL OF REAR BRACKET

5. Removing the insulated brush from the brush holder permits separation of the rear bracket from the yoke
6. If it is necessary to remove overrunning clutch, put a metal cylinder of suitable size over the end of armature shaft so it rests on the stop ring. Then tap the cylinder lightly with a hammer, the stop ring towards armature and lock ring. Removing ring from groove in shaft so the overrunning clutch and the stop ring is removed from the armature clutch.

Cleaning Parts

CAUTION 1. Do not immerse parts in cleaning solvent. Immersing the field coil, yoke assembly, armature and solenoid will damage the insulation. Wipe these parts with a cloth only.

2. Do not immerse the overrunning clutch in cleaning solvent. The clutch is prelubricated at the factory, and solvent will wash lube from clutch.

3. Wash all other parts in solvent and dry the parts.

Inspection of Parts

See Figures 18-34 for parts inspection information.

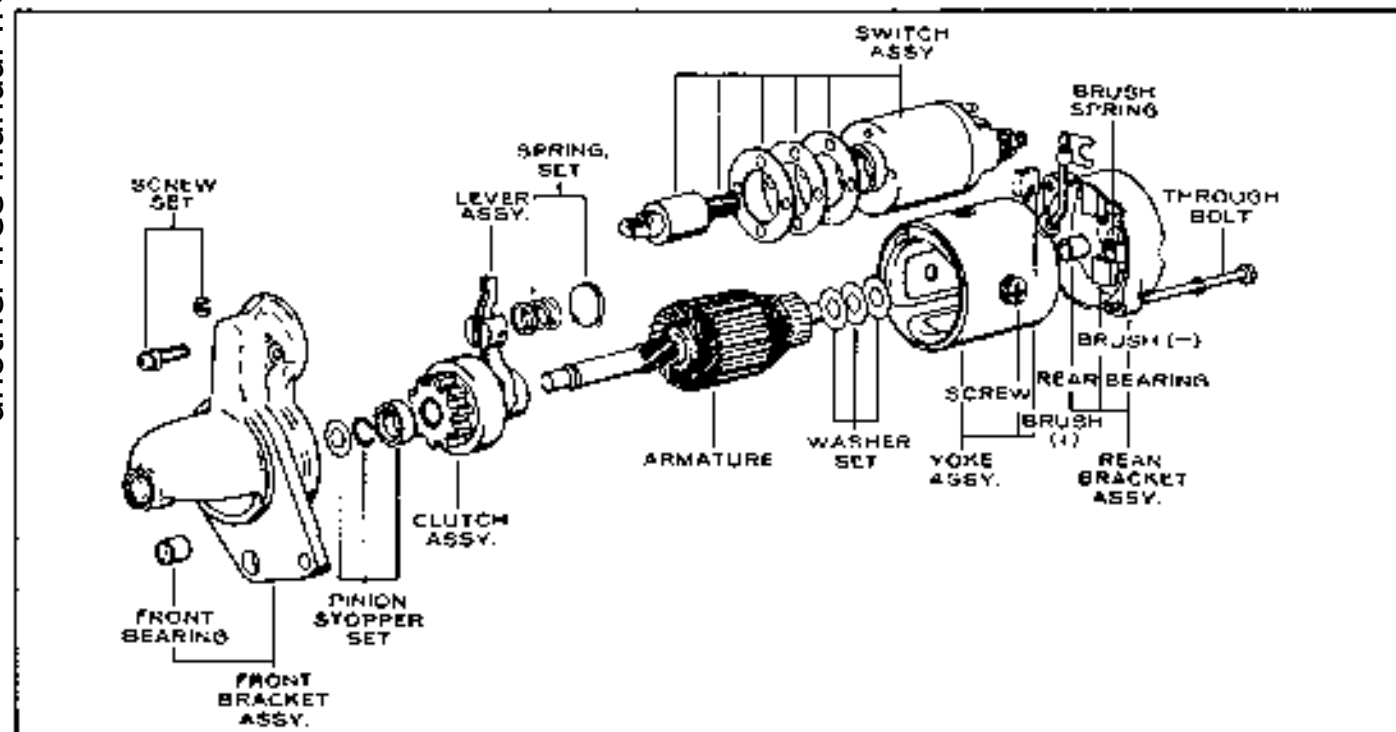

FIGURE 18-34. EXPLODED VIEW OF STARTER

Rev 10-75

Brush Replacement

Replace brushes that are worn out to the wear limit line. Replace brushes after removing the rear bracket.

When resoldering the brushes, make a low resistance connection, using a high temperature solder and resin flux.

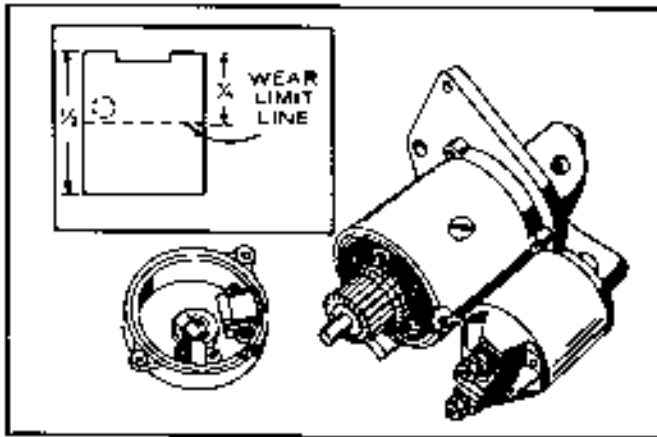

FIGURE 18-35. BRUSH WEAR LIMIT

Brush Springs: Take the spring tension using a push-type spring scale until the top of a new brush protrudes 1/16 inch (1.59 mm) from the brush holder. Spring tension should be 36 to 48 ounces (1020 to 1360 g). See Figure 18-21.

Overrunning Clutch: The pinion gear should rotate smoothly in one direction (not necessarily easily), but should not rotate in opposite direction. If pinion gear does not function properly, or if pinion gear is worn or burred, replace the overrunning clutch.

Reassembly

Reassembly is the reverse of disassembly. Note the following.

1. Lubricate armature shaft and splines with a very light grade oil. A medium or heavy oil and grease may cause faulty operation in cold weather.

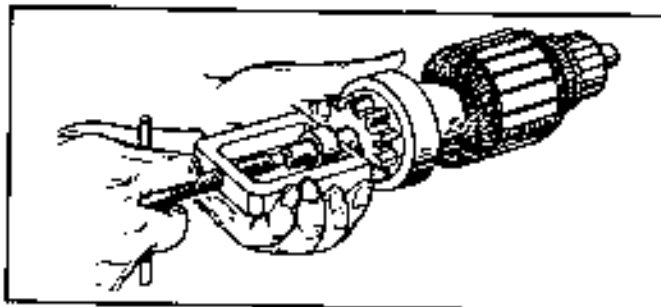

FIGURE 18-36. INSTALL OVERRUNNING CLUTCH

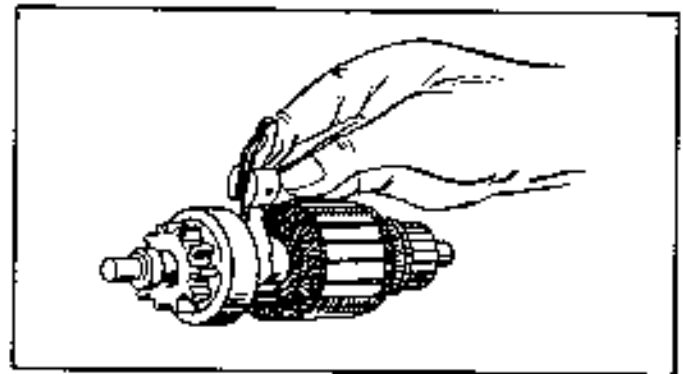

FIGURE 18-37. SHIFT LEVER INSTALLATION

2. Install the overrunning clutch assembly, the ring on the armature shaft. Drive pinion stopper far enough on shaft to install stop ring. Then using a puller (Figure 18-36), pull stopper against ring.
3. Apply a small amount of Lubriplate on the shift lever pivot pin and lever holders. Install the shift lever over the clutch assembly with position indicated in Figure 18-37. This is important; if the shift lever is not properly positioned the pinion gear travel is restricted causing a locking in the clutch mechanism.

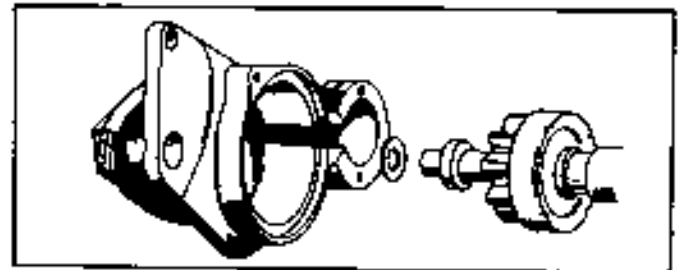

FIGURE 18-38. ARMATURE INSTALLATION

4. Place the thrust washer on the drive end of the shaft. Slide the armature with the lever into the front bracket.
5. Place the lever spring and the spring holder into the front bracket with the direction shown in Figure 18-39.

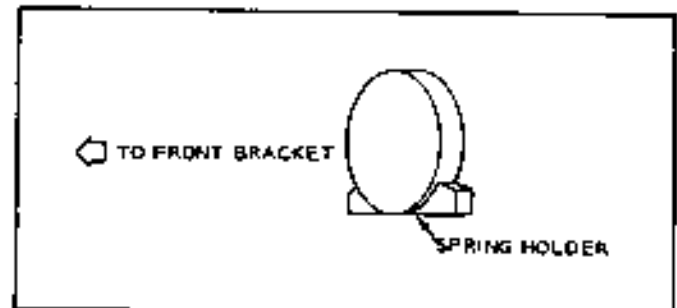

FIGURE 18-39. LEVER SPRING POSITION

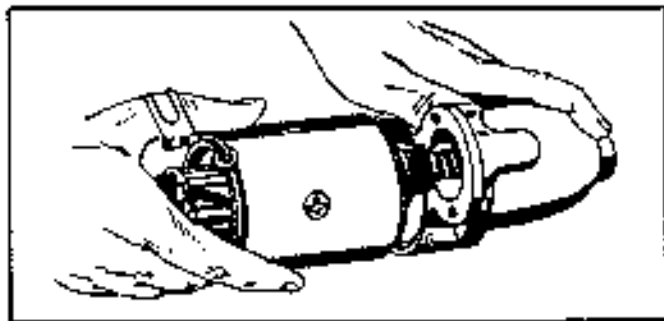

FIGURE 18-40. YOKE POSITIONING

6. Position the yoke to the front bracket. Be sure the yoke is properly indexed to the front bracket.
7. Place the thrust washer (steel) and washer (fiber) on the commutator end of shaft, and apply a small amount of Lubriplate on the shaft. If three washers are used, the fiber washer is placed between the steel washers.

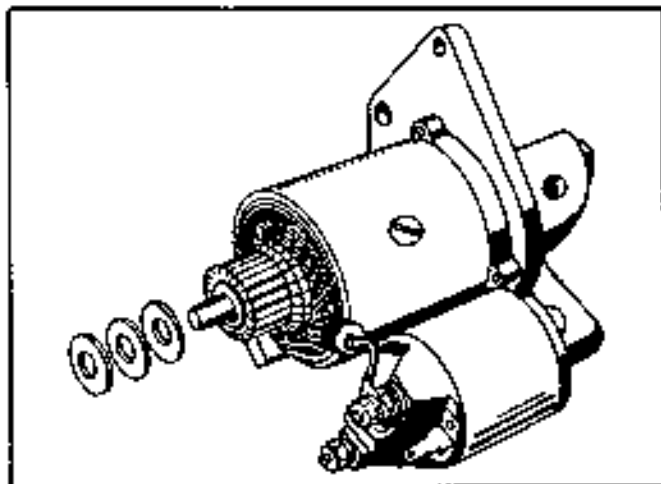

FIGURE 18-41. WASHER PLACEMENT

8. Insert two brushes and springs in their brush holders and push them against spring tension. Secure the brushes by iron wires as shown in Figure 18-42.

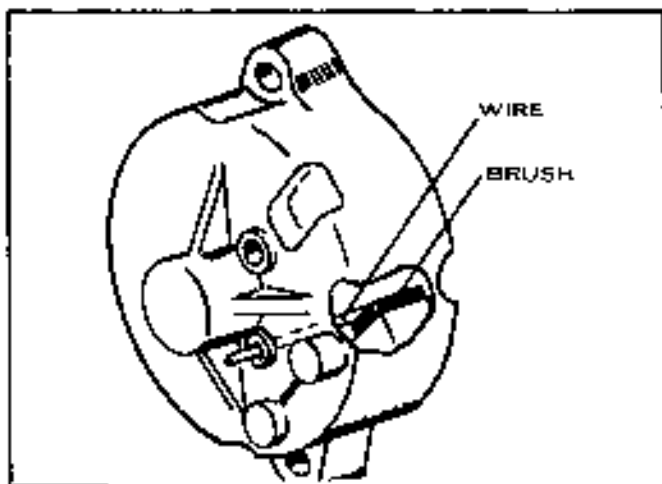

FIGURE 18-42. SECURE BRUSH SPRINGS

9. When securing the brushes, position the rear bracket to the yoke, inserting the rubber gasket to the slot of the rear bracket. After the rear bracket is installed to the yoke, with draw iron wires so the brushes and the commutator come in contact. Then, insert the bushings into the holes to keep out dirt.
10. Fasten through-bolts securely.
11. Install the solenoid plunger over the top of the shift lever in the front bracket. Be sure that the pinion gear is moved when the plunger is pulled manually.
12. Install the solenoid.

CAUTION The return spring, in this case, should be straight in the proper position between the bore of the solenoid and the bore of the plunger.

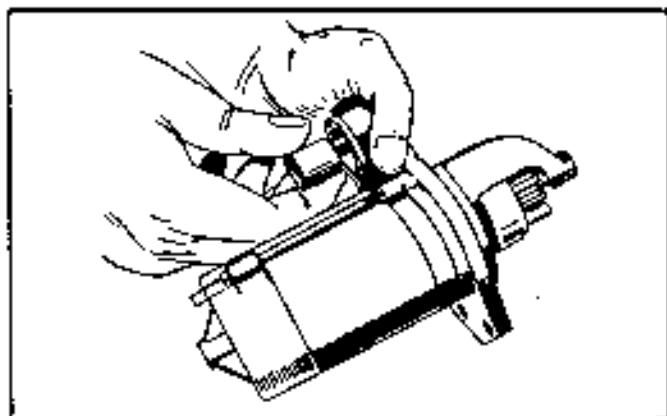

FIGURE 18-43. PLUNGER INSTALLATION

Testing and Adjusting

Adjusting Pinion Clearance: After the starter is reassembled adjust the pinion clearance to give sufficient clearance between the end of the pinion and the stop ring when the pinion is in mesh with the ring gear of the engine.

1. Connect a battery of the proper voltage between the "Switch" terminal of the solenoid and the bracket of the starter (ground), so the pinion will travel.
2. Then, push the pinion back until play is taken out of the lever and the clutch mechanism.
3. Measure the pinion clearance.
4. The clearance should be 0.002 to 0.008 inch (0.051 to 0.203 mm). Adjust by removing the solenoid and increasing or decreasing the number of the fiber washers.

Increasing the number of the washers decreases clearance, and decreasing the number of the washers increases clearance.

Rev 10-75

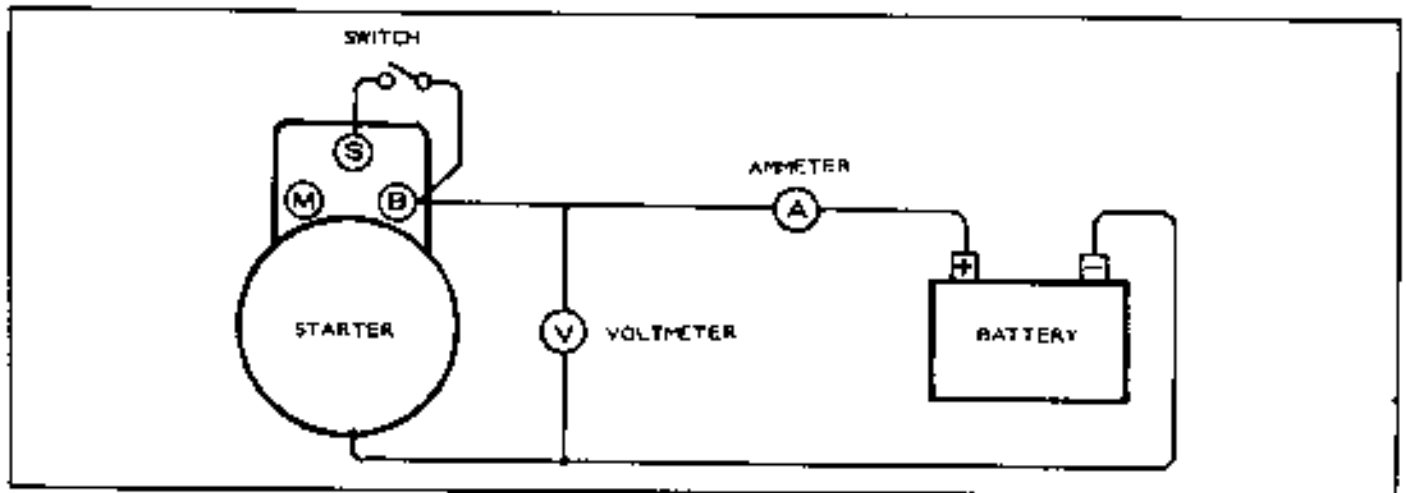

FIGURE 18-44. NO LOAD TEST

No Load Test: For this test connect starter as shown in Figure 18-44. The values of this test should be as follows:

Battery Voltage.....	11.5 Volts
Minimum RPM.....	6000 RPM
Maximum Current Draw.....	55 Amps

CAUTION

1. Before installing the starter, be sure starter and engine mounting surfaces are free of dirt and oil. These surfaces must be clean to make a good electrical contact.

2. Do not operate the starter more than 30 seconds, or serious damage may result. Starters are not designed for continuous operation.

3. When the engine does not rotate, do not hold the starter in a stall condition more than 10 seconds.

4. The wires between the battery and the starter should be of sufficient size to carry the electric load without excessive voltage drop.

BF TRACTOR STARTER

Starter Disassembly

1. Remove the through-bolts and separate the end cap, the housing and the armature (see Figure 18-45, Spec A; Figure 18-46, Spec B).

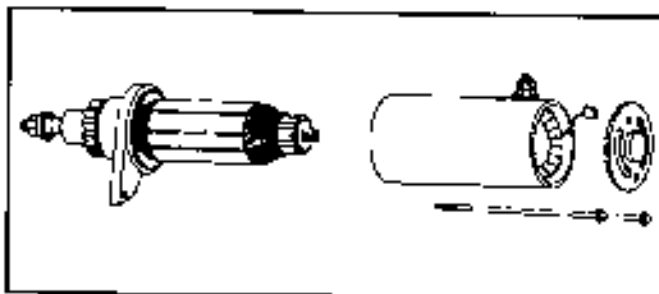

FIGURE 18-45. STARTER DISASSEMBLY (SPEC A)

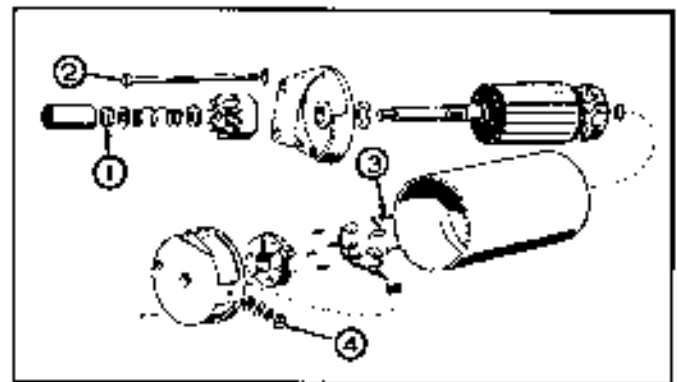

FIGURE 18-46. STARTER DISASSEMBLY (SPEC B)

2. Disassemble the drive assembly and the drive end cap by loosening the self-locking nut.

Inspection of Parts

See Figures 18-14 through 18-20 for parts inspection information.

Brush Service

Brush Inspection: If brushes are worn shorter than 1/4 inch (6 mm), replace them. Check to see that brushes move smoothly in the brush holders. See Figures 18-47.

Brush Spring Inspection (Spec A only): Check brush spring tension as shown in Figures 18-21. If spring tension reads 17 to 25 ounces (482 to 809 g), the spring is satisfactory.

Starter Assembly

Reassembly is the reverse of disassembly. When reassembling, observe the following:

1. Wipe off any dirty parts with a clean cloth or blow clean using filtered compressed air.

Bearings must not be immersed in cleaning fluid. These parts should be cleaned with a brush dipped in clean engine oil.

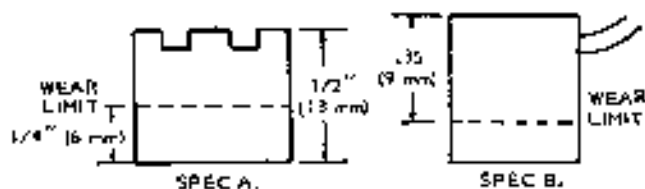

FIGURE 18-47. BRUSH WEAR LIMIT

2. Apply SAE 10W-30 oil on the armature shaft, spline and bearings.

Reassembly (Spec B only)

1. Assemble brushes so that chamfered side is away from the brush springs and position the brush shunts so that they will not contact the commutator or commutator end cap.
2. Torque bolts (Figure 18-45, item 3) to a value of 3 to 3-1/2 ft-lbs. (4.1 to 4.7 N•m).
3. Torque nut (Figure 18-46, item 4) to a value of 4 to 5 ft-lbs. (5.4 to 6.8 N•m).
4. Apply a thin film of grease to the commutator end of the armature shaft and to the portion of the shaft that contacts the bearings. Apply a generous film of Lubriplate "Aero" grease to the shaft thread.

5. Torque stop nut (Figure 18-46, item 1) to a value of 20 to 25 ft-lbs. (27 to 34 N•m). Hold armature in a vise.
6. Torque thru-bolts (Figure 18-46, item 2) to a value of 4-1/2 to 6 ft-lbs. (6.1 to 8.1 N•m).

CAUTION Do not exceed the rated voltage of the motor (12-VDC). Excessive voltage could demagnetize the motor permanent magnet field.

Inspecting Reassembled Starter

No Load Test: Connect the starting motor as shown in Figure 18-44.

The values for this test are as follows:

	Spec A	Spec B
Battery Voltage	11.5 Volts	12.0 Volts
RPM	3000 rpm (min)	4,800 - 6,100
Maximum Current Draw	25 amperes	32 amperes

1. To ensure good electrical contact, make sure starter-to-engine mounting surfaces are free of dirt or oil.
2. When tightening attaching bolts and nuts, hold starter gear into ring gear to assure proper backlash.
3. Tighten battery to starting motor wire securely.

CAUTION Starter motors are not designed for continuous operation. Do not operate more than 30 seconds per "ON" cycle. Do not operate starter more than 10 seconds in a stall condition if engine will not rotate. Serious damage could result if these time limits are exceeded.

TABLE 18-1. STARTING SYSTEMS

MANUAL START	EXCITER CRANKING (Generator Sets Only)	AUTOMOTIVE TYPE	
AK AJ LK LKB CCK CCKA CCKB MCKK NB	AJ MAJ LK CCK MCKK NH MJB MJC	BF CCK CCKA CCKB NH NHA, NHB, NHC JB JC RJC	DJA MDJA DJB MDJB DJC MDJE MDJC MDJF RDJC RDJF

TABLE 18-2. CRANKING TORQUES (AUTOMOTIVE STARTER)

MODEL	BREAKAWAY		CRANKING		RPM	TEMP
	VOLTS	AMPS	VOLTS	AMPS		
BF CCK CCKA CCKB	10.8	150	11.5 11.2	25 120	300	
NB NH NHA, NHB, NHC JB	9.0	200	8.5	175	134	-20°F (-29°C)
JC, MJC	9.8	220	10.8	160	310	-20°F (-29°C)
DJA	9.8	370	7.0	155	150	-20°F (-29°C)
DJB, MDJB			11.5	55	380	+30°F (-1°C)
DJC, MDJC			9.6	160	332	+30°F (-1°C)
MDJE			10.6	160	310	+30°F (-1°C)
MDJF			10.4	210	190	+30°F (-1°C)
RDJF			8.8	240	145	+30°F (-1°C)
			7.2	390	145	25°F (-32°C)
			17.2	265	145	-25°F (-32°C)
			17.2	265	145	-25°F (-32°C)

TABLE 18-3. CRANKING TORQUES (EXCITER CRANKING)

MODEL	BREAKAWAY		CRANKING		RPM	TEMP
	VOLTS	AMPS	VOLTS	AMPS		
1AJ	8.8	285	10.5	120	723	-10° F (-23° C)
2.5AJ	8.5	270	9.0	120	550	15° F (-26° C)
2.5AJ, 2.5MAJ	8.0	350	9.0	260	580	0° F (-18° C)
LK	5.0	350	8.0	250	390	-21° F (-29° C)
4.0CCK, MCCK	5.9	495	9.0	235	370	
5.0CCK	6.2	430	10.0	135	420	0° F (-18° C)
6.5MCCK	9.0	144	10.1	104	500	+69° F (21° C)
10.0CCKB	8.6	355	9.1	250	330	-15° F (-26° C)
NB	7.3	300	7.2	300-140	300-500	-25° F (-32° C)
NH	5.5	400	7.5	280-160	290-340	-25° F (-32° C)
DJA, MDJA	9.8	370	10.4	210		-30° F (- 1° C)
JB	7.4	375	8.5	220	200	-20° F (-29° C)



TOOL CATALOG

THE PROPER TOOL MAKES ANY JOB EASIER

The equipment listed in this catalog is intended to perform special repair functions. These are labor saving devices which save mechanics time and enable them to do a better job. Some of the items are factory production line tools. Blueprints are available for many of the Onan designed special tools which are recommended for use on Onan built engines. All tool prices are listed by part number in the Parts Price List (L-835).

TABLE OF CONTENTS

TITLE	PAGE
Valve Service Equipment	2
Cylinder, Piston, Ring, Connecting Rod Equipment	5
Engine Bearing Equipment	8
Special Service Tools and Equipment . . .	10
Gauges, Meters, and Test Equipment . . .	12
Diesel Test Equipment	19
Miscellaneous Equipment	21

VALVE SERVICE EQUIPMENT

VALVE SEAT DRIVER

Simplifies installation of valve seats into cylinder block.

PART NO.	SERIES
420-0070	AH, BH, AJ, AK, MAJ, MKH
420-0071	ACK, CCK, CCKB, CK, LK, LKB, BF, BG MCK
420-0270	All J-Series
420-0308	NH, NHA, NHB, NHC, NB

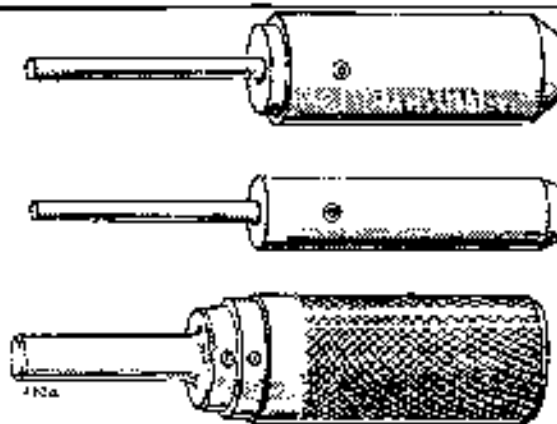

VALVE GUIDE DRIVER

Assures correct removal of valve guides. Also used for installation of "J" series valve guides.

PART NO.	SERIES
420-0203	CK, DSP, MDSP, DRP, DRN, DSL, MDSL
420-0300	CCK, CCKB, LK, LKB, MCK, NH, NHA, NHB, NHC, NB, BF, BG All "J" Series.

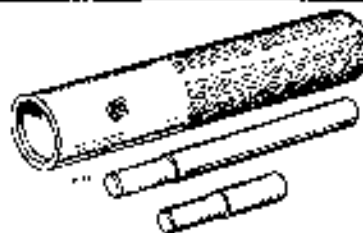

VALVE SPRING COMPRESSOR

Heavily built, adjustable, safety lock compressor allows use of both hands when valve spring is compressed.

PART NO.	SERIES
420-0119	A1E

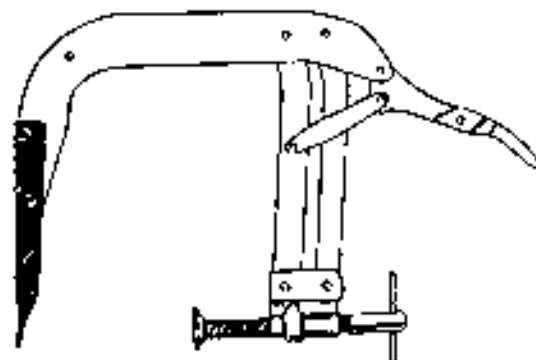

VALVE LOCK REPLACER

Simplifies installation of split valve keepers.

PART NO.	SERIES
420-0105	ALL

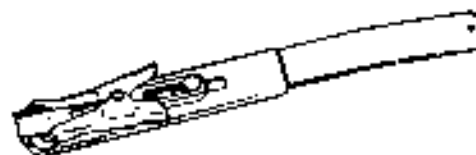

VALVE TAPPET ADJUSTING WRENCH

PART NO.	SERIES
420-0139	A11

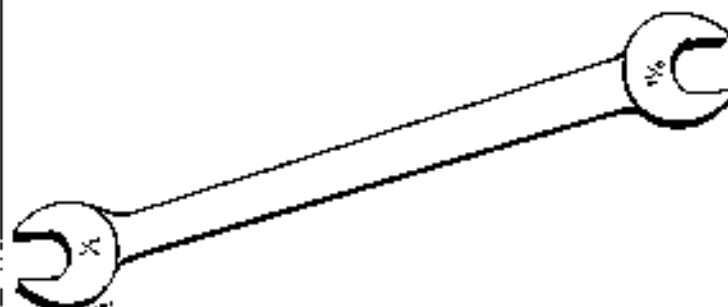

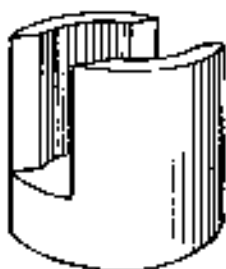

VALVE SPRING COMPRESSOR TOOL

Designed especially for all Onan Diesel and "J" series - this tool simplifies removal of valve locks. Use with arbor press or valve spring compressor (420-0119).

PART NO.	SERIES
420-0210	All ONAN Diesel and J-Series.

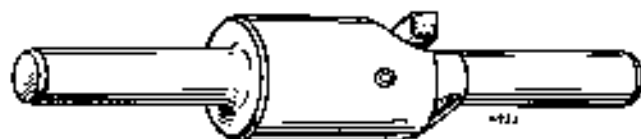

VALVE SEAT REMOVER

Mount in drill press and cut out old seat to remove.

PART NO.	SERIES
420-0311	All "J" Series NH, NHA, NHB, NHC, NB

Replacement cutter blade - 420-0274



VALVE SEAT STAKER

Assures tight fit of seat. Eliminates danger of insert loosening in its bore.

PART NO.	SERIES
420-0309	NB, NHA, NH, NH3, NHC (Intake)
420-0310	NB, NH, NHA, NHB, NHC (Exhaust)



VALVE GUIDE HONING SET

Produces straight round holes - fast set up - easy to use. For popular sizes 5/16", 11/32", 3/8", and 7/16". Includes various mandrels, sleeves, stones, and metal storage box.

PART NO.	SERIES
420-0305	ALL

Replacement Stone (5/16" and 11/32") - 420-0363

Replacement Stone (3/8", 13/32, and 7/16") - 420-0364

VALVE SEAT CUTTER KIT

This is a much needed portable service tool for shop or field use.

Cutters are simple in construction easy to operate and store and highly recommended in the small engine market.

Long lasting, precision tungsten carbide blades cut the hardest seats.

PART NO.	SERIES
----------	--------

420-0349	ALL
----------	-----

Replacement cutter blade - 420-0351.

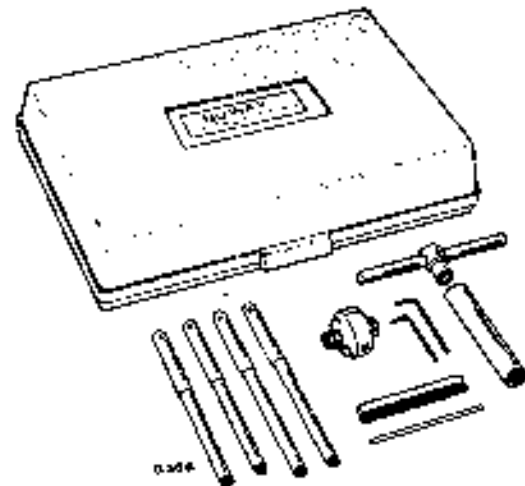

CYLINDER, PISTON, RING, CONNECTING ROD EQUIPMENT

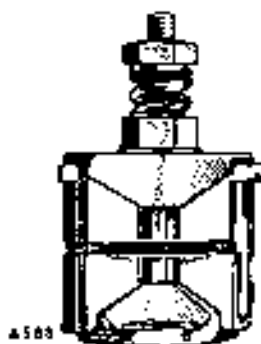

RIDGE REAMER

Removes ridge from top of cylinder wall. Bore diameter is 2-1/2" to 4-1/8".

PART NO.	SERIES
420-0260	ALL SETS

Replacement cutter blade - 420-0261



CYLINDER HONE

Maintains alignment of original bore. Reconditions cylinder bore with less stock removal. Produces any finish required - fast stock removal. Assures fast seating of all rings (including chrome). Shipped with rough and medium finishing stones. Cylinder range 2-11/16" to 4-1/4". Use with cast iron, steel, and hardened sleeves.

PART NO.	SERIES
420-0304	ALL SETS

Replacement Stone (Roughing 70 grit) - 420-0365
Replacement Stone (Finishing 150 grit) - 420-0366



CYLINDER HONE "QUICK COUPLER"

Use with 420-0304 cylinder hones, make cylinder honing an easier-faster operation. Permits drill (electric or air) to be quickly coupled or uncoupled from cylinder hone. Allows operator to have both hands free for removing hone from cylinder or for stone changing operation.

PART NO.	SERIES
420-0306	ALL SETS

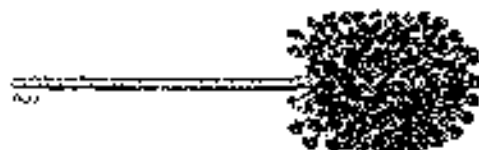

CYLINDER WALL MICRO-FINISHING BRUSH

Produces ideal cylinder wall finish to seat rings extremely fast. Reduces blow-by, lowers oil consumption, gives higher compression. Excellent for deglazing cylinder walls. Provides good cross hatch pattern.

PART NO.	SERIES
420-0328	AK
420-0329	AJ
420-0320	LK, LKB, OCK, OCKB, NB, NHA, NHB, NHC, NB, AL "J" Series, All One marine, BF, BG

RING COMPRESSOR, EXPANSION

Ratchet lock action compresses all rings evenly for easy insertion into cyl. bore.

PART NO.	SERIES
420-0234	ALL

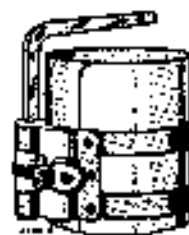
**RING COMPRESSOR, PLIERS TYPE**

Furnished complete with pliers and (6) bands covering range of 2-7/8" to 4-3/8". Fits bands at 180° or 90° angle. Self-locking with instantaneous release.

PART NO.	SERIES
420-0331	ALL

**PISTON RING SPREADER**

Prevents ring breakage from over-expanding. Adjustable for 2-3/4" and larger rings.

PART NO.	SERIES
420-0146	ALL

**CONNECTING ROD ALIGNING SET**

The SUNNEN alignment set can be used on all rods up to 16-1/2" long with a 1-1/2" dia. or larger bearing. Checks rods with or without pistons. Includes aligner, V-block, bend & twist indicator, bending bar, side clamping fixture and instructions.

PART NO.	SERIES
420-0173	All sets except those listed with Aligning Adapter Set.

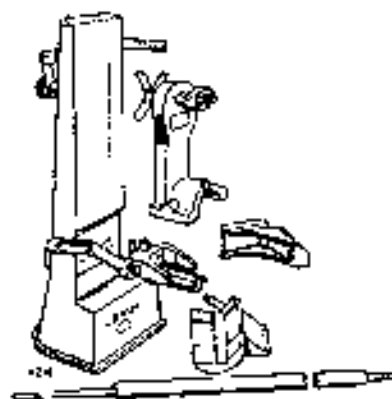
**CONNECTING ROD ALIGNING SET SMALL ROD ADAPTER**

Adapts Rod Aligner to smaller size conn. rod bearing size of 1-1/8" to 1-1/2" diameter.

PART NO.	SERIES
420-0195	AH, BH, AJ, AK

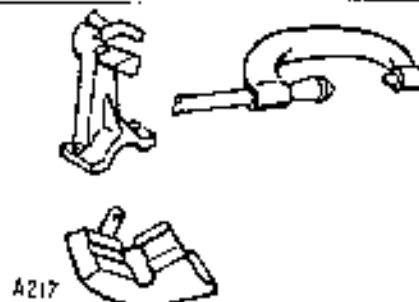

A217

CYLINDER, PISTON, RING, CONNECTING ROD EQUIPMENT (CON'T.)

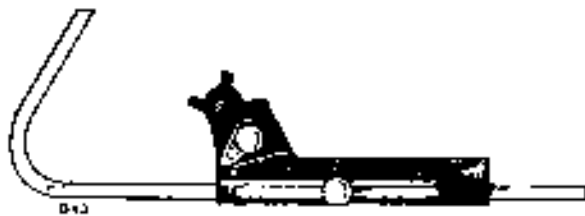

PISTON GROOVE CLEANER

Removes carbon from piston ring grooves.

Spring-loaded cleaning cutter doesn't gouge or climb out of grooves.

WIDTHS: Complete with two cutters covering the following groove— $1/16''$, $.070''$, $5/64''$, $3/32''$, $1/8''$, $5/32''$, $3/16''$ and $.220''$.

PART NO.
420-0332

SERIES
ALL

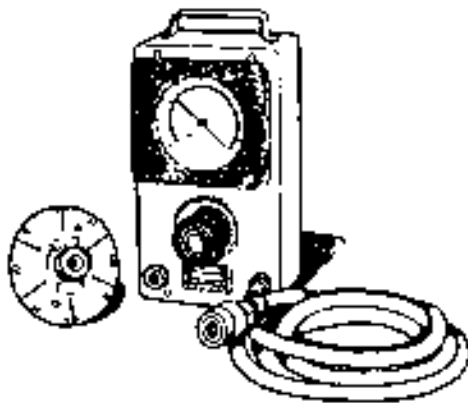

CYLINDER LEAKAGE TESTER

Gauge provides direct reading of cylinder leakage.

Operates on your shop air supply, clip-on TDC indicator and test lamp.

PART NO.
420-0343

SERIES
ALL

ENGINE BEARING EQUIPMENT

OIL SEAL GUIDE & DRIVER

Simplifies seal installation and prevents damage to seal surfaces.

BEARING PLATE	SERIES
420-0181 *	BH, CK, ACK, CCK, CCKB, MCKK, LK, AJ, AK, NH, NHA, NHB, NHC, NB, BF, BG (includes loader)
420-0282	Loader only

420-0207	CW, DSL, DSP, DRP, MDSL, MDSP, DRN
----------	------------------------------------

420-0250	All J-Series
420-0338	Loader only (available separately)

GEAR COVER

420-0183	CW, DSL, DSP, DRP, MDSL, MDSP, DRN
----------	------------------------------------

420-0312	AK, AJ
----------	--------

420-0281	All J-Series
420-0339	Loader only (available separately)

420-0313	NH, NHA, NHB, NHC, NB, CCK, CCKB,
----------	-----------------------------------

CRANKSHAFT

420-0182	BF, BG, MDSL, MDSP
----------	--------------------

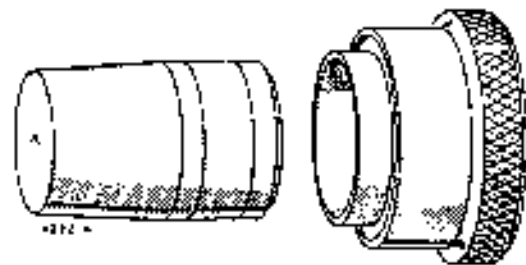
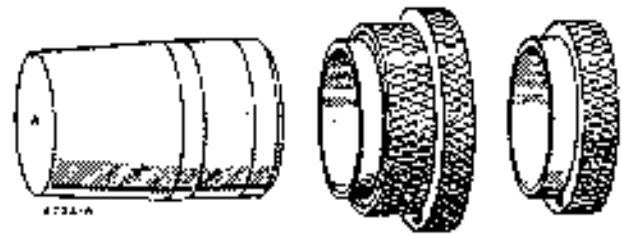

BEARING CLEARANCE GUIDE

"PLASTI-GAGE" simplifies fitting bearing clearances of split bearings. Use on Con. Rod split bearings.

PART NO.	SIZE RANGE
420-0256	0.002" to 0.006"
420-0257	0.004" to 0.009"



MAIN BEARING DRIVER

Simplifies installation of precision sleeve main bearings.

PART NO.	SERIES
420-0127	AH, BH, MK10, AJ, AK, MAJ
420-0201	CW, MDSP, DSP, DRP, DSL, MDSL, DRN

NOTE: Also see listing for combination main and cam bearing drivers.



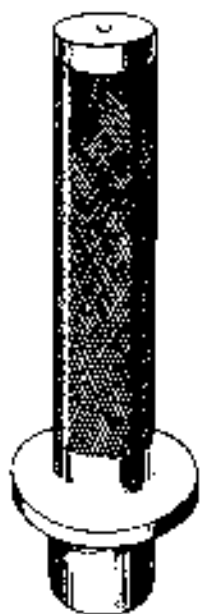

CAM BEARING DRIVER

Simplifies installation of precision sleeve cam bearings.

FRONT BEARING

PART NO.	SERIES
420-0206	CW, MDSP, DSP, DRP, DSL, MOSL, DRN

REAR BEARING

420-0205	CW, MDSP, DSP, DRP, DSL, MOSL, DRN
420-0264	JA, DJA, MOJA

CENTER BEARING

420-0254	All 4 Cylinder J & DJ Series
----------	------------------------------

NOTE: Also see listing for combination main and cam bearing drivers.

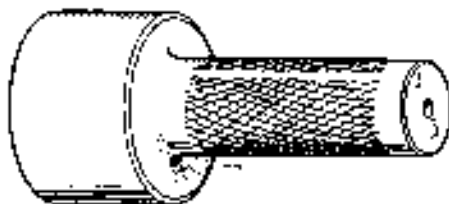

TIMING ADV. MECH. COVER DRIVER

For proper installation of spark advance cover.

PART NO.	SERIES
420-0296	NH, NHA, NHB, NHC, CCK, CCKB Engines

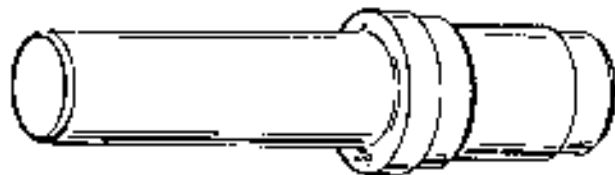

COMBINATION BEARING REMOVER - MAIN AND CAM

Makes removing old bearings a simple task.

PART NO.	SERIES
420-0325	LK, LKB, CCK, CCKB, AJ, AK, NH, NHA, NHB, NHC, NB, BF, BG, AJ, AK, Cam Bearing only.

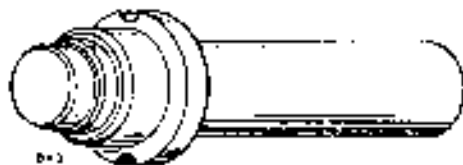

COMBINATION MAIN AND CAM BEARING DRIVER

Makes easier installation of precision crankshaft and camshaft bearings. Use one tool for many different models.

PART NO.	SERIES
420-0324	AH, BH, MKB, AJ, AK, MAJ, Cam Bearing only, CK, LK, LKB, ACK, CCK, CCKB, MCKK, NH, NHA, NHB, NHC, NB, BF, BG
420-0326	JJ, MJB, JC, MJC, DJB, MOJB, DJC, VDJC, RDJC, MH, NHA, NHB, NJC, NB

SPECIAL SERVICE TOOLS & EQUIPMENT

GEAR PULLER

Special arm: for removal of crankshaft gear.

PART NO.	SERIES
420-0072	ALL

Replacement arm - 420-0148

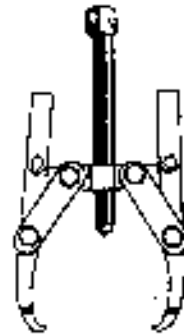

GEAR PULLER RING

Mounts to crankshaft gear. Extended edge permits use with any gear puller.

PART NO.	SERIES
420-0275	All J-Series (tapped 1/4" x 20 thds.)
420-0248	All sets except J-Series (tapped #10-32 thds.)

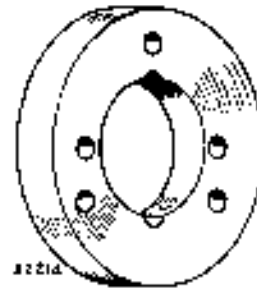

SNAP RING PLIER

Adjustable to simplify removal of snap rings.

PART NO.	SERIES
420-0107	ALL



FLYWHEEL PULLER

Simplifies flywheel removal.

PART NO.	SERIES
420-0100	BH, CK, LE, LKB, CCK, CCKB, NH, NHA, NHB, NHC, NB, MCKK, BF, BG, All "J" Series.

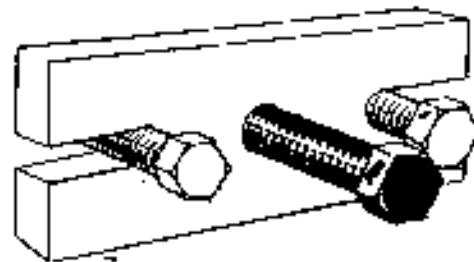

BALL POINT DRIVER

Use on Allen head (socket head) type screws, in hard-to-get-at places. Works at any angle.

PART NO.	SERIES
420-0342	LK, CCK, NH, BF, BG,
420-0355	Use for adjusting breaker points.



SPECIAL SERVICE TOOLS & EQUIP. (CONT.)

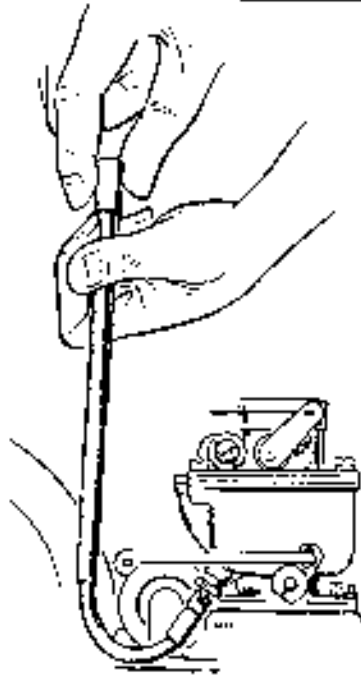

CARBURETOR ADJUST. WRENCH

Simplifies carb. main jet adjustments. Eliminates burns from hot manifold or exhaust pipes. Use with any cross-pin adjustment jet.

PART NO.	SERIES
420-0169	BI, CK, CCK,
420-0294	CCKB, J Series (With Zenith Carb.) MCK, NH, NHA, NHB, NHC, NB All CCK mobile models

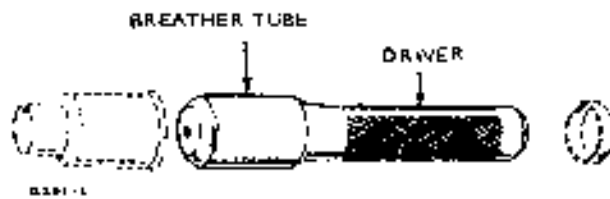

NEW STYLE 4 BALL NYLON BREATHER TUBE AND CORE PLUG DRIVER

Saves time and simplifies installation of breather tubes that have been removed or damaged. Also used for removal of core plugs on "J" Series only.

PART NO.	SERIES
420-0353	CCK - CCKA - CCKB DJB - DJC - DJM - J-60 J120 - JB - JC - MCK MDJB - MDJC - MDJE MDJF - NJC - NH - NHC RDJC - RDJF - RJC



**BREATHER TUBE DRIVER
(Baffle Style)**

Saves time and simplifies installation of breather tubes that have been removed or damaged.

PART NO.	SERIES
420-0354	CCK - CCKA

MAGNETO ADJUSTING GAUGE

With timing marks to simplify ignition timing. Assures proper pole shoe air gap on flywheel magnets.

PART NO.	SERIES
420-0096	AH, MKH, AJ, AK, MAJ
420-0249	CCK, NB, NH, NHA, NHB, NHC



TEST SPARK PLUG

Simulates normal compression firing. Ground to engine and connect to tension lead.

PART NO.	SERIES
420-0255	ALL

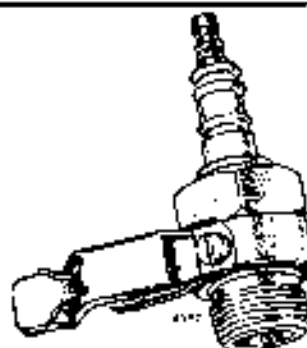

TACHOMETER

Mechanical, inexpensive, requires contact with rotating part.

PART NO.	SERIES
302-0193	ALL



COMPRESSION GAUGE

Measures compression of 0 to 250 psi. Neoprene adapter fits all spark plug holes.

PART NO.	SERIES
420-0108	ALL

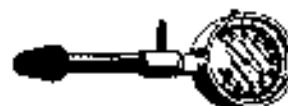

VACUUM & PRESSURE GAUGE

Measures vacuum of 0 to 28 in., pressure 0 to 10 psi. Complete with hose, adapter, & instructions.

PART NO.	SERIES
420-0310	ALL

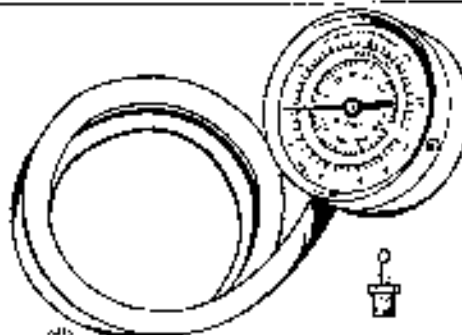

another free manual from www.searstractormanuals.com

ONAN LOAD-TEST PANEL

Load-Test panels are specially designed for use by Onan Distributors and Dealers for the following purposes:

1. Measuring generator electrical output.
2. Making proper adjustments to governor, carburetor and brush rig.
3. Making sales demonstrations of generating plants.

Four Panels are available:

No. 300-0219 AC only (W.D. 625-0128)

No. 300-0058 AC and DC (W.D. 84041)

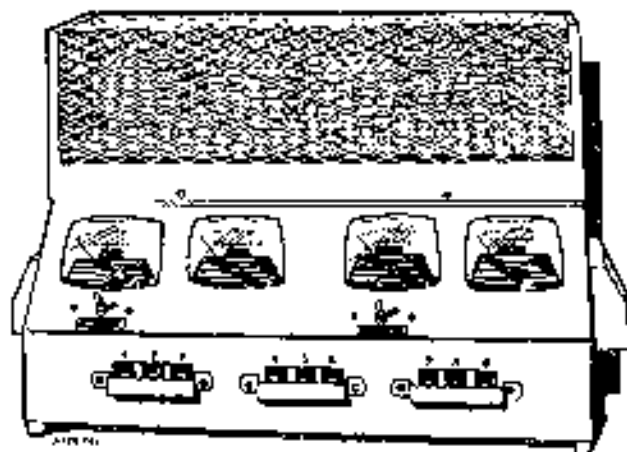

No. 300-0608 AC only w/frequency meter
(W.D. 625-0908)

No. 300-1044 AC only - no meters
(W.D. 625-1246)

The AC voltmeters have 0-150 and 0-300 volt scales.

The DC voltmeters have 0-60 and 0-150 volt scales.

The AC Ammeter has a 0-50 ampere scale. The DC Ammeter has a 0-100 ampere scale.

Toggle switches connect the proper voltmeter or frequency meter scale into the circuit.

Nine numbered sockets, for cone heaters or lamps for use as loads, have individual switches correspondingly numbered.

300-0058 panel provides 5400 watts of load at 120 or 240 volts and 3600 watts at 32 volts.

300-0058 has 1 set each of 120 volt and 32 volt elements. 240 volt testing requires nine (9) 322-0008 elements. All test panels include 913-6 Instruction Book. Leads 420-0301 and 420-0302 not included.

300-0219, 300-0608, and 300-1044 have 1 set of 120 volt elements. Provide 5400 watts load.

300-1044 AC load bank. Slave unit only, no meters. Contains nine 600 watt resistive elements to increase load capacity of above units to 10,800 watts.



LOAD-TEST PANEL LEADS

6 feet long - with lugs - connect to panel
with battery clips - connect to generator.

PART NO.

420-0301 (red) 420-0302 (black)

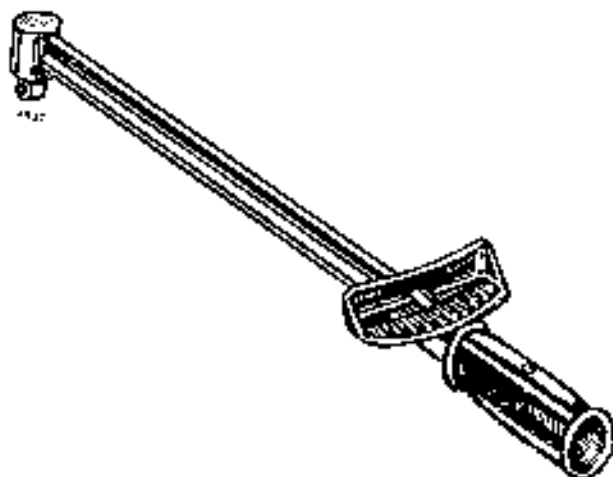

TORQUE WRENCH

Measures torque accurately.

PART NO.

420-0221 (Moving arm)
0-50 ft-lb.

420-0222 (Moving arm)
0-100 ft-lb.

MAGNETO ANALYZER

Tests and checks variety of battery and magneto ignition coils, start solenoids, selenium rectifiers, condensers, spark plugs, distributors, etc. With instructions.

PART NO.

420-0235



PHASE SEQUENCE INDICATOR

Connect to any 3 phase circuit - observe sequence lights - gives instant, positive phase sequence without damage to components.

PART NO.

420-0317

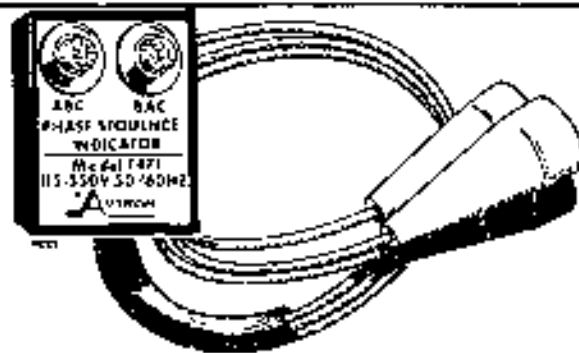

ARMATURE GROWLER

Tests armature for short circuits. Adjustable to test all Onan-built armatures. Designed for bench use.

PART NO.

420-0194

SERIES

Up to 10KW

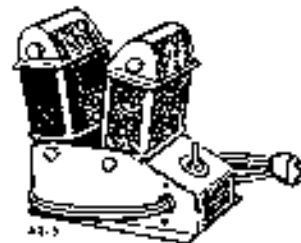

AC-DC MULTIMETER

Check ac-dc volts, ohms, dc milliamperes, complete with test leads & instructions. SCALE: AC-volts, 0-15, 150, 750, 3000. DC volts, 0-15, 75, 300, 750, 3000. DC-milliamps, 0-15, 150, 750, ohms 0-30, 3000, 300,000

PART NO.

302-0195

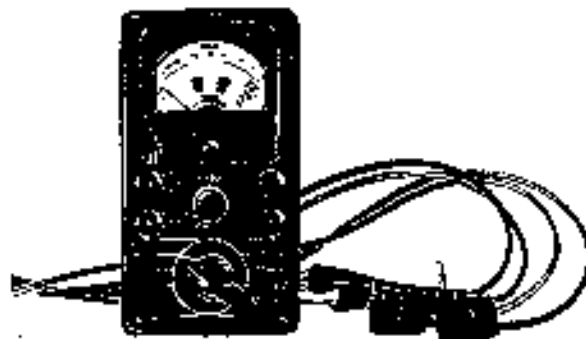



PORTABLE VOM MULTITESTER

Designed for use where measurements must not appreciably disturb the circuit being tested. FEATURES: high 20,000 ohms/volt DC and 10,000 ohms/volt AC sensitivities on all ranges.

PART NO.	SERIES
420-0368	AJ Sets

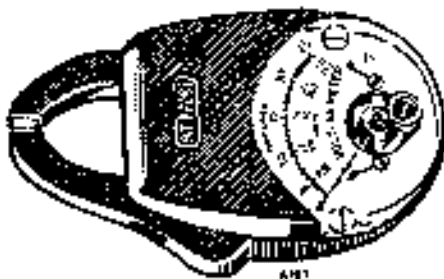

SNAP-AROUND AC VOLT, AMMETER

Insulated jaws snap around conductor for ammeter. Test leads for voltmeter. SCALE: 0-100 amps., 0-150/600 volts.

PART NO.
420-0187

Meter case with zipper - 420-0189



10-POWER SENSITIZER

Increase sensitivity of 420-0187 snap-around volt-ammeter by 10 times. Also useful as split plug for two conductor wire. Includes special case.

PART NO.
420-0188



SNAP-AROUND VOLT, OHM, AMMETER

Check voltage, ohms, amps. Insulated jaws snap around conductor. Adjustable scale. Case and test leads included. SCALE: 0-300 amps, 0-600 volts, 25-ohms mid-scale.

PART NO.
420-0262

TESTER - CLAMPROBER

A quick and convenient way to test AC current voltage and resistance without the need for wire connections.

PART NO.	SERIES
420-0369	ALL

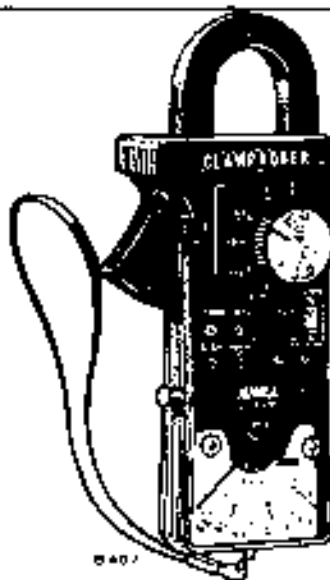

FREQUENCY METERS

Accurate reed-type meter indicates frequency

PART NO.	VOLTAGE (HERTZ)
302-0213	120-Volt, 60 Hertz
302-0221	240-Volt, 60 Hertz
302-0234	120-Volt, 50 Hertz
302-0256	240-Volt, 50 Hertz

Instrument case - 1 meter, 301 0500, 2 meter 301 0994.

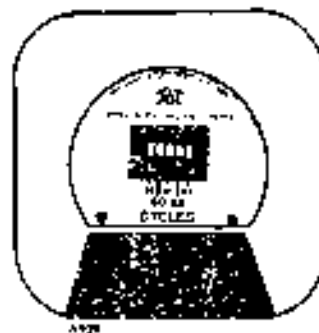

PLUG-IN AC VOLTMETER

Tests AC line voltage SCALE- 0-150 volts.

PART NO.
302-0300

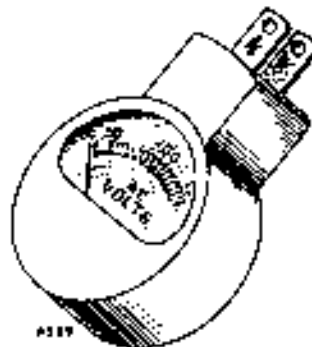

GAS PRESSURE MANOMETER

Accurate and portable device for determining velocity, static pressure, leakage, gas line pressure. Use for calibrating controls and balancing fuel-air ratios, etc.

PART NO.
420-0236

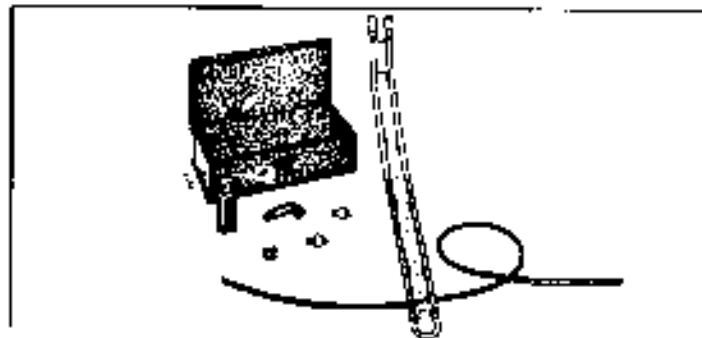

GAS PRESSURE GAUGE

Direct reading diaphragm-type. 0 to 20 oz. pressure, 0 to 35" water column. Instructions included.

PART NO.
420-0280

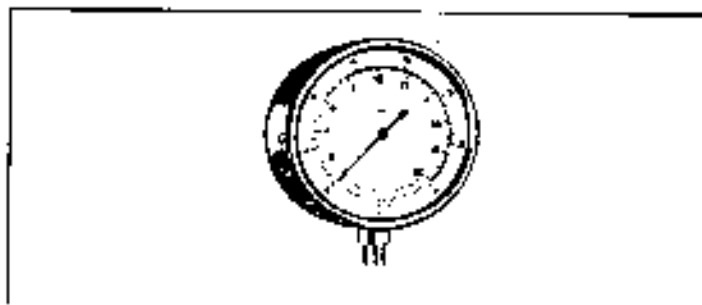

ENGINE CONTROL TESTER

Used on YB Engine Controls, this plug-in module will check out the complete system (except relays). Time delays for I.O.P., overcrank and start/stop can also be checked.

PART NO. **SERIES**
420-0336 WF, HFC, DFU, FT, DVB, DYH.

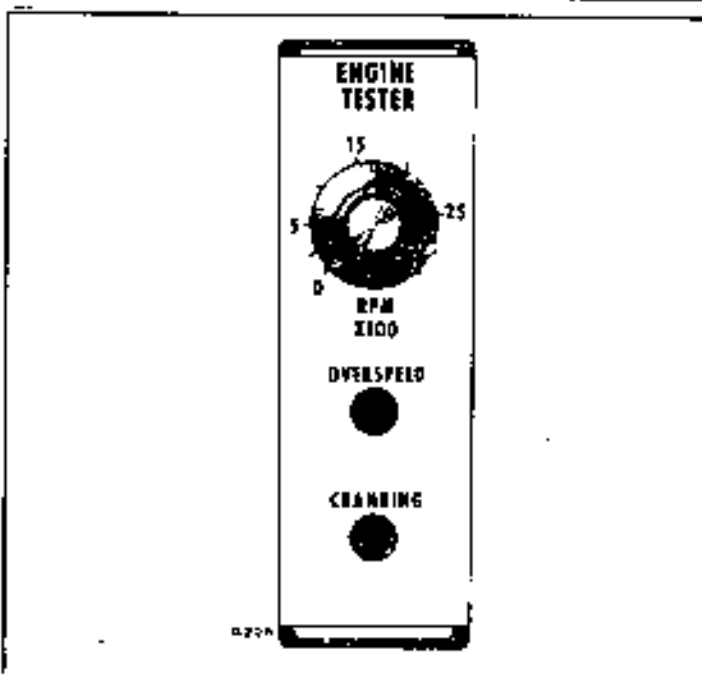

CIRCUIT BOARD PULLER

This puller is a must for removal of the printed circuit module in "YB" generator set controls. Insert tool in pre-drilled holes of printed circuit module and apply steady pressure to remove module. Makes removal of any printed circuit module "a snap".

PART NO. **SERIES**
420-0348 ALL

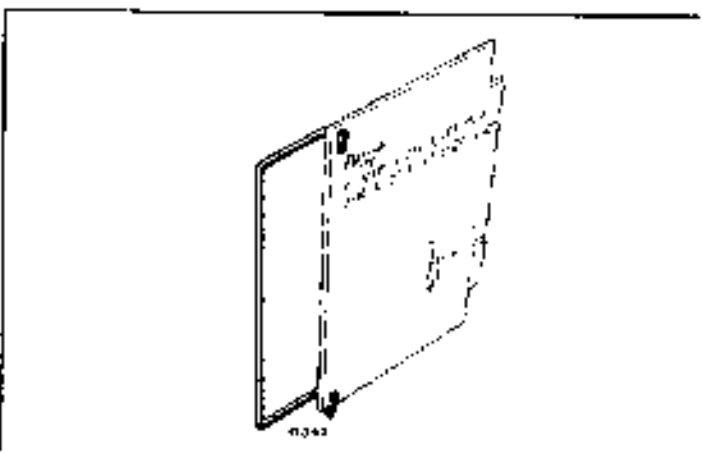

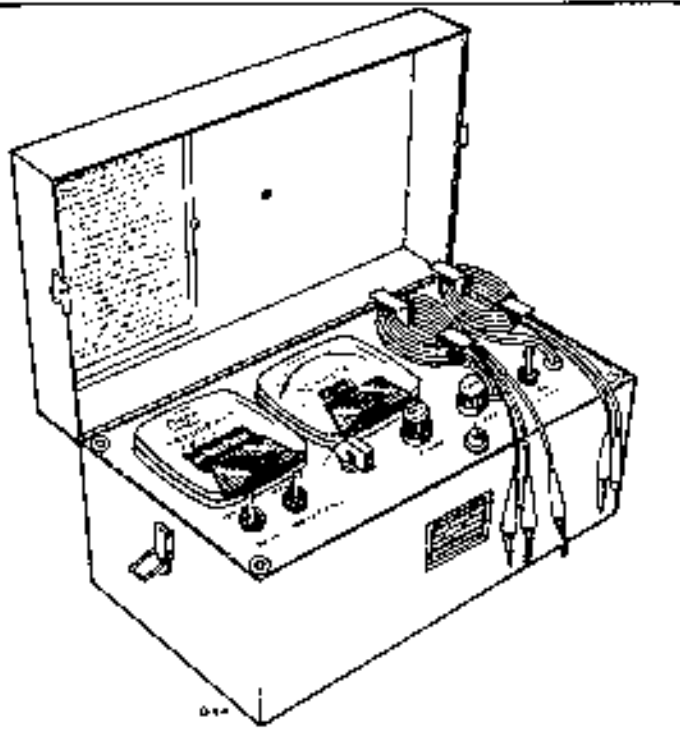

ONAH MULTI-TESTER

A 5-purpose tester designed for field adjusting voltage-sensitive relays, generator field-flashing, voltage & frequency tests, continuity checks, electrical component tests, phase rotation. Includes: AC-voltmeter 0-600 volt, frequency meter (11 reed), buzzer and light continuity indicator, and phase rotation light. Includes 6 volt lantern battery.

PART NO.
420-0303

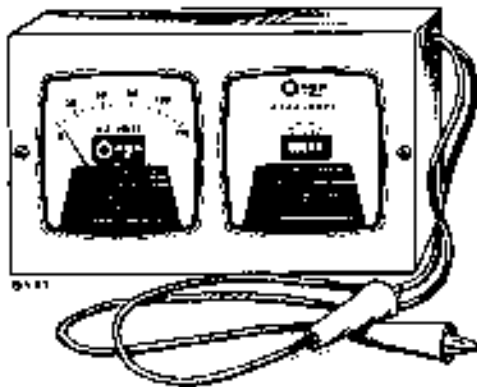

AC VOLTS AND FREQUENCY TESTER

A necessary instrument pack for installation and maintenance of R.V. electric generator sets. AC voltmeter 0-150 volt, plus 5 reed frequency meter 59-63 Hz.

PART NO.
420-0335

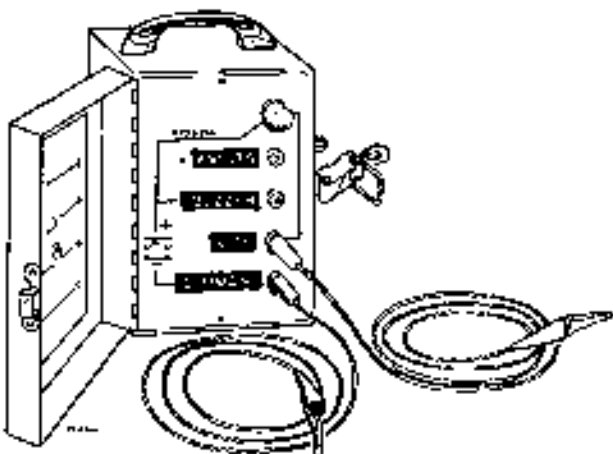

CONTINUITY TESTER

Simplifies all continuity checks. Buzzer and light indicators. Voltage tap of 6VDC. Test prods included. Uses a 6-volt battery (lantern type) not included.

PART NO.
420-0290

DIESEL NOZZLE TESTER

Bacharach precision upright type nozzle tester with connector set. Tests nearly all types of nozzles for bench use.

PART NO.	SERIES
420-0184	All Diesel Units.

Metal case for tester - 420-0185

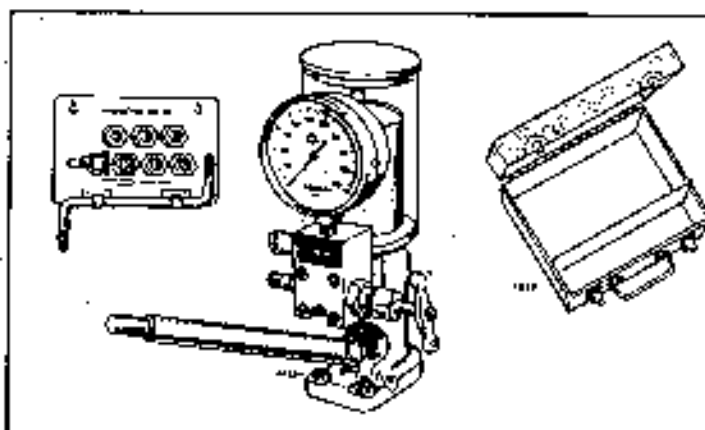

PORTABLE DIESEL NOZZLE TESTER

Bacharach precision horizontal type nozzle tester with connector set. Tests nearly all types of nozzles for bench or portable use.

PART NO.	SERIES
420-0333	All Diesel Units.

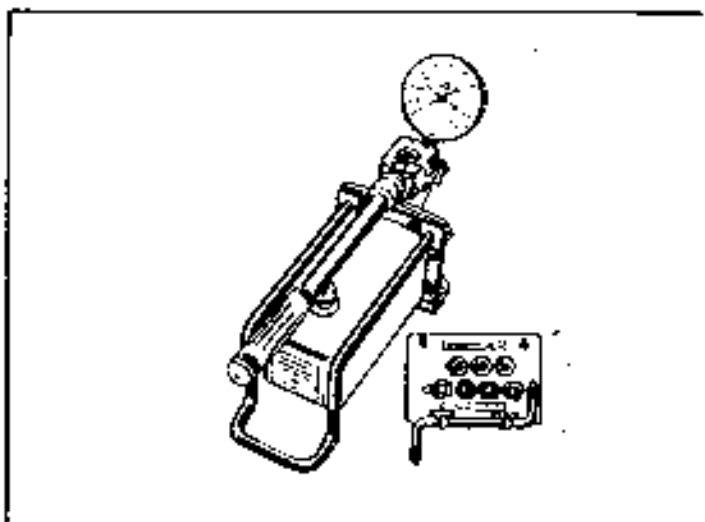

DIESEL COMPRESSION TESTER

Includes adapter and check valve. Adaptable to nearly all diesel engines.

PART NO.	SERIES
420-0283	All Diesel Units

Metal case - 420-0284

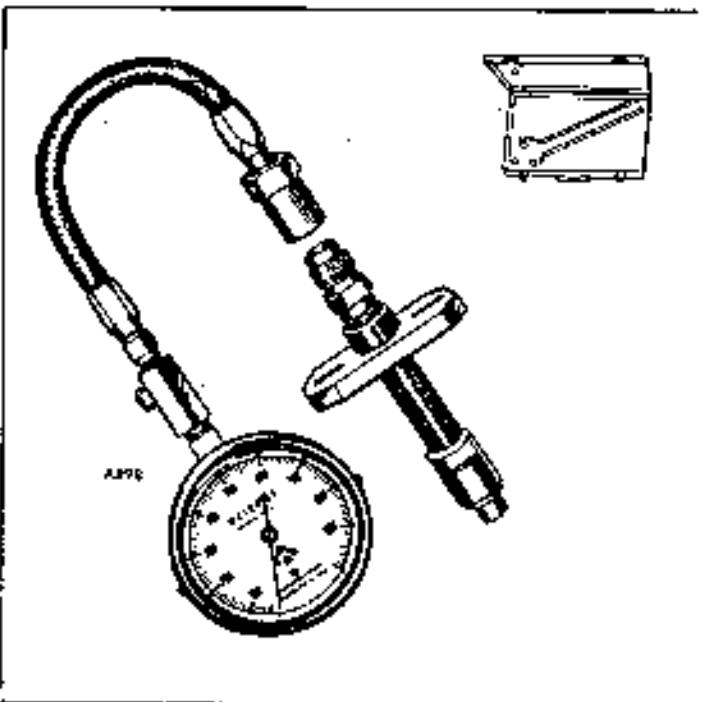

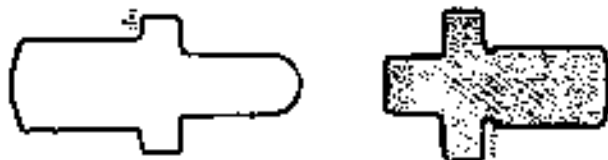

TIMING GAUGE

Assures accurate timing of injection pump.

PART NO.	SERIES
147-0049	DSP (prior to serial #417052)
147-0051	DSP (Begin serial #417052) DSL, MDL, DRP

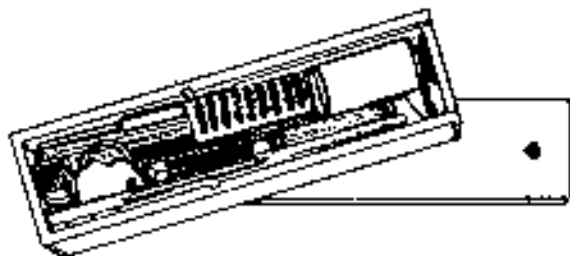

DIESEL PINTLE NOZZLE CLEANING KIT

Enables cleaning nozzles rather than complete replacement. Simplifies cleaning carbon fouled nozzles. Complete instructions included. Sold only as complete kit.

PART NO.
420-0208

Contains:

- Brush, Bristle
- Tallow, 1/2 Ounce
- Brush, Wire (Brass)
- Stick Set, Nozzle Cleaning
- Stick Set, Polishing
- Scraper, Pressure Chamber

- Scraper, Valve Seat
- Sleeve, Centering
- Wiper Set, Valve
- Glass, Magnifier
- Block, Pintle Cleaning
- Box, Tool



NOZZLE CENTERING SLEEVE

For centering nozzle in nozzle holder cap nut during assembly to the nozzle holder.

PART NO.	SERIES
420-0321	All Onan built Diesels



DELIVERY VALVE TEST FIXTURE

Checks delivery valve seat for leakage. Used with Diesel nozzle tester.

PART NO.	SERIES
420-0322	All Onan built Diesels

MISCELLANEOUS EQUIPMENT

BRUSH SEATING STONE

Special compound for rapid seating of new brushes.

PART NO.

420-0258

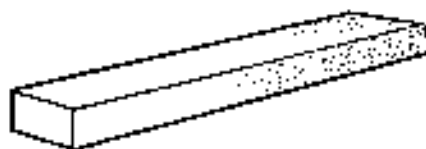

COMMUTATOR STONE

Use for smoothing rough commutators or slip rings. Quickly removes carbon glaze.

PART NO.

420-0259



SPRAY CAN PAINT

Pressurized can of spray paint for simple touch-up.

PART NO.

COLOR

525-0137

Silver Green

525-0216

Matine White

525-0305

Onan Green



ONAN SERVICE LABEL KITS

Self adhesive labels of general instructions and Onan Logo. Simple to install.

PART NO.

USE

98-1100

General purpose

98-1807

Marine units

98-2028

Welders

98-2290

Diesels

98-2629

Industrial engines

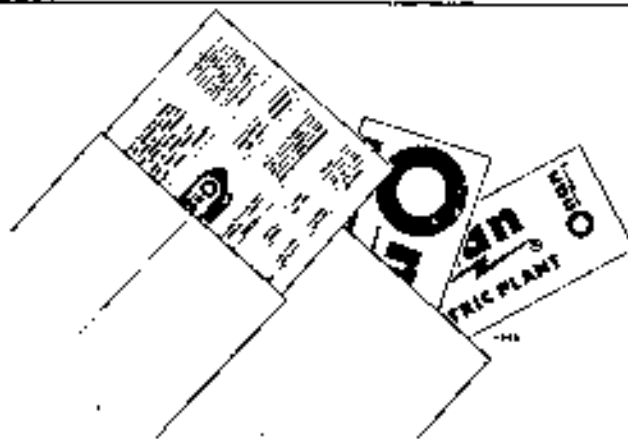

SPARK PLUG WRENCH

Fits most common spark plugs.

PART NO.

SERIES

417-0147

ALL SETS



HYDROMETER, BATTERY

Checks specific gravity. Has graduated scale to show condition of battery.

PART NO.

SERIES

416-0325

ALL SETS

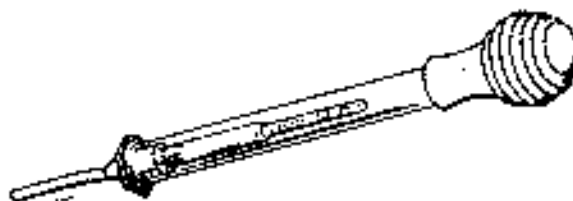

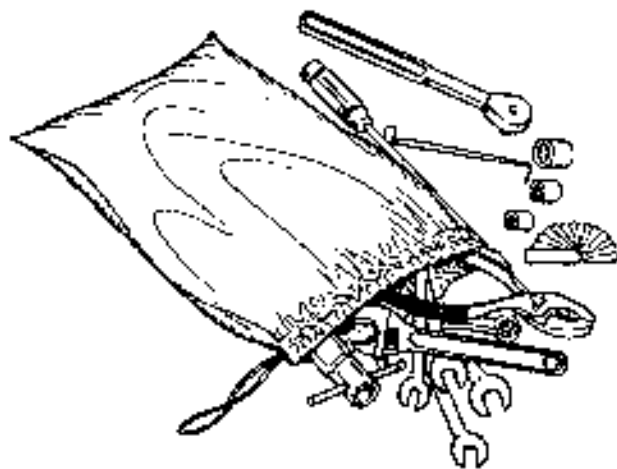

GENERAL PURPOSE TOOL KIT

This tool kit provides most necessary hand tools to service and maintain small units. All tools are finest quality to assure durability.

NOTE: Tools illustrated are typical and do not always represent actual tools included in kit.

PART NO. 420-0160

Each tool set contains the following (or equivalent):

- Adjustable Wrench
- Feeler Gauge
- Screw Driver - Offset
- Pliers
- Tool Bag

- Socket Wrench Handle
- Sockets 7/16", 1/2", 9/16"
- Open End Wrenches, 3/8", 7/16", 1/2", 9/16", 5/8"
- Spark Plug Wrench
- Screw Driver - Flat

another free manual from www.searstractormanuals.com

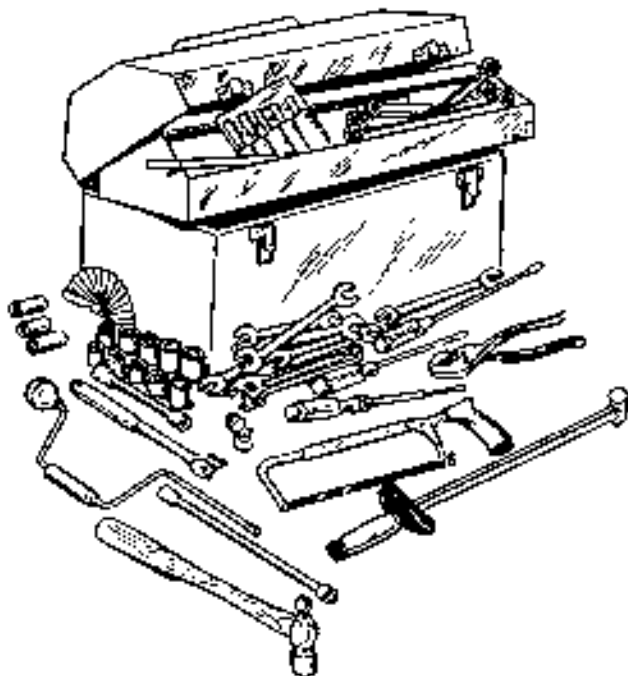

MAINTENANCE AND SERVICE TOOL SET

This tool set provides the necessary hand tools to overhaul, service, and maintain small and large units. All tools are finest quality to assure durability.

NOTE: Tools illustrated are typical and do not always represent actual tools included in kit.

PART NO. 420-0285

Each tool set contains the following (or equivalent):

- Tool Box With Tote Tray
- Feeler Gauge
- Socket Wrench Handle (1/2" Drive) and Ratchet
- Socket Wrench Extension (5" and 10")
- Sockets (1/2" Drive) 7/16", 1/2", 9/16", 5/8", 11/16", 3/4", 13/16", 7/8", 15/16", 1"
- Sockets - Deep Wall 5/8", 3/4", 15/16"
- Socket Wrench Speed Handle
- Socket Wrench U-Joint
- Open End Wrench 3/8", 7/16", 1/2", 9/16", 5/8", 3/4", 7/8", 15/16", 1", 1-1/16", 1-1/8"

- Adjustable Wrench, 8-inch
- Screw Driver - Flat, Wedge, Clutch
- Pliers
- Pty Bar, 20-inch
- Punch & Chisel Set
- Hammer - Ball Peen
- Hacksaw
- Torque Wrench 0-175 lbs.
- Box End Wrench 3/8", 7/16", 1/2", 9/16", 5/8", 3/4", 11/16", 13/16", 3/4", 7/8", 15/16", 1", 1-1/16", 1-1/4"

