

DAWN

ENGINE

Service Manual

**P216, P218
P220, P224**

Performer Series

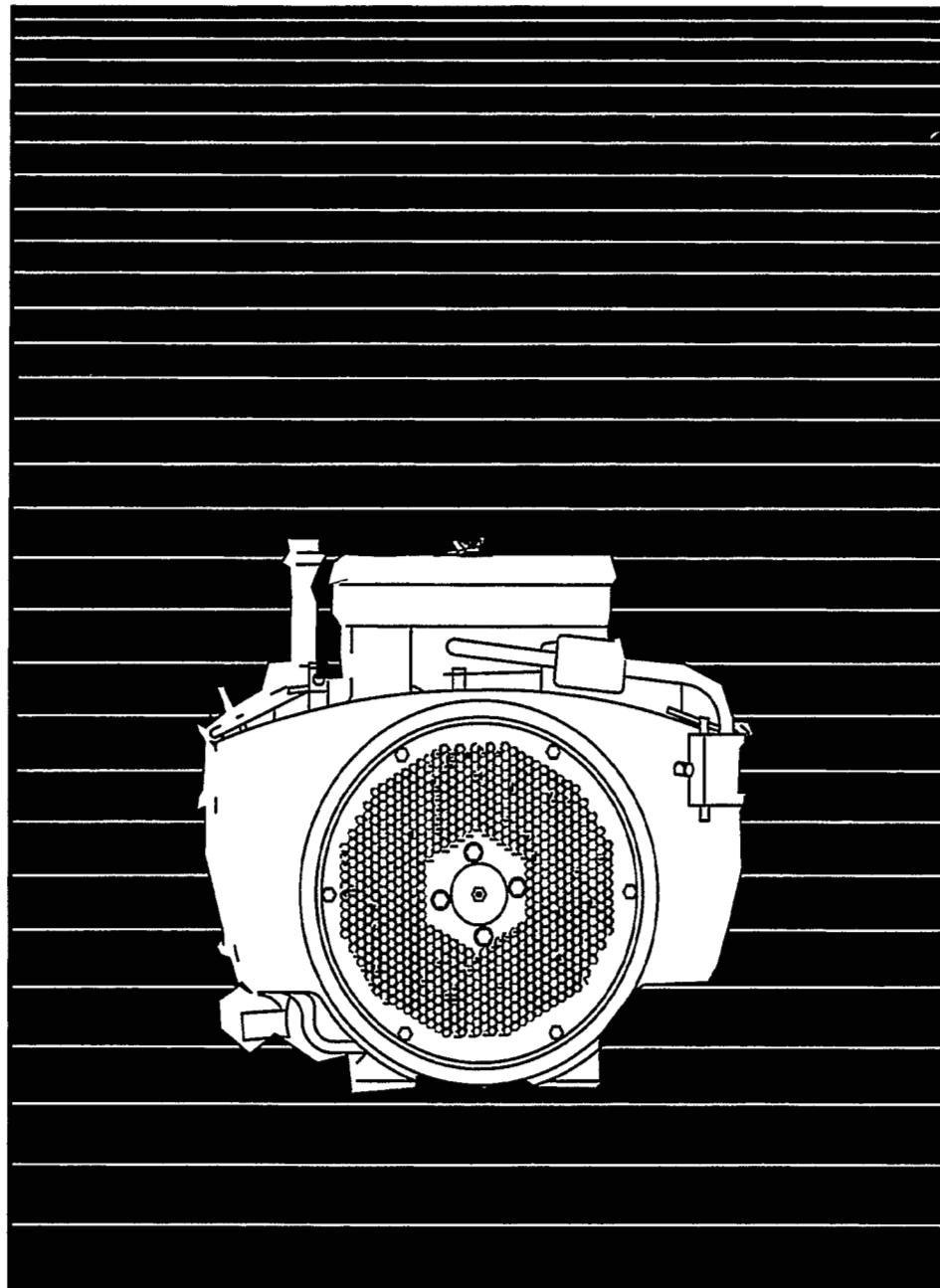

Safety Precautions

It is recommended that you read your engine manual and become thoroughly acquainted with your equipment before you start the engine.

⚠ DANGER This symbol if used warns of immediate hazards which will result in severe personal injury or death.

⚠ WARNING This symbol refers to a hazard or unsafe practice which can result in severe personal injury or death.

⚠ CAUTION This symbol refers to a hazard or unsafe practice which can result in personal injury or product or property damage.

Fuels, electrical equipment, batteries, exhaust gases and moving parts present potential hazards that can result in serious, personal injury. Take care in following these recommended procedures. All local, state and federal codes should be consulted and complied with.

⚠ WARNING This engine is not designed or intended for use in any type of aircraft. Use of this engine in aircraft can result in engine failure and causes serious personal injury or death.

General

- Provide appropriate fire extinguishers and install them in convenient locations. Use an extinguisher rated ABC by NFPA.
- Make sure that all fasteners on the engine are secure and accurately torqued. Keep guards in position over fans, driving belts, etc.
- If it is necessary to make adjustments while the engine is running, use extreme caution when close to hot exhausts, moving parts, etc.

Protect Against Moving Parts

- Do not wear loose clothing in the vicinity of moving parts, such as PTO shafts, flywheels, blowers, couplings, fans, belts, etc.
- Keep your hands away from moving parts.

Batteries

- Before starting work on the engine, disconnect batteries to prevent inadvertent starting of the engine.
- DO NOT SMOKE while servicing batteries. Lead acid batteries give off a highly explosive hydrogen gas which can be ignited by flame, electrical arcing or by smoking.
- Verify battery polarity before connecting battery cables. Connect negative cable last.

Fuel System

- DO NOT fill fuel tanks while engine is running.
- DO NOT smoke or use an open flame in the vicinity of the engine or fuel tank. Internal combustion engine fuels are highly flammable.
- Fuel lines must be of steel piping, adequately secured, and free from leaks. Piping at the engine should be approved flexible line. Do not use copper piping for flexible lines as copper will work harden and become brittle enough to break.
- Be sure all fuel supplies have a positive shutoff valve.

Exhaust System

- Exhaust products of any internal combustion engine are toxic and can cause injury, or death if inhaled. All engine applications, especially those within a confined area, should be equipped with an exhaust system to discharge gases to the outside atmosphere.
- Do not use exhaust gases to heat a compartment.
- Make sure that your exhaust system is free of leaks. Ensure that exhaust manifolds are secure and are not warped by bolts unevenly torqued.

Exhaust Gas is Deadly!

Exhaust gases contain carbon monoxide, a poisonous gas that can cause unconsciousness and death. It is an odorless and colorless gas formed during combustion of hydrocarbon fuels. Symptoms of carbon monoxide poisoning are:

- Dizziness
- Headache
- Weakness and Sleepiness
- Vomiting
- Muscular Twitching
- Throbbing in Temples

If you experience any of these symptoms, get out into fresh air immediately, shut down the unit and do not use until it has been inspected.

The best protection against carbon monoxide inhalation is proper installation and regular, frequent inspections of the complete exhaust system. If you notice a change in the sound or appearance of exhaust system, shut the unit down immediately and have it inspected and repaired at once by a competent mechanic.

Cooling System

- Coolants under pressure have a higher boiling point than water. DO NOT open a radiator pressure cap when coolant temperature is above 212°F (100°C) or while engine is running.

Keep the Unit and Surrounding Area Clean

- Make sure that oily rags are not left on or near the engine
- Remove all unnecessary grease and oil from the unit. Accumulated grease and oil can cause overheating and subsequent engine damage and present a potential fire hazard.

Table of Contents

TITLE	PAGE
General Information	1-1
Specifications	2-1
Dimensions and Clearances	3-1
Assembly Torques and Special Tools	4-1
Engine Troubleshooting	5-1
Oil System	6-1
Fuel System	7-1
Ignition and Battery Charging	8-1
Engine Wiring Diagram	8-7
Starting System	9-1
Engine Disassembly	10-1

▲WARNING

EXHAUST GAS IS DEADLY!

Exhaust gases from all fuels (including diesel, gasoline, liquid propane, natural gas) contain carbon monoxide, an odorless and colorless gas. Carbon monoxide is poisonous and can cause unconsciousness and death. Symptoms of carbon monoxide poisoning can include:

- *Dizziness*
- *Nausea*
- *Headache*
- *Weakness and Sleepiness*
- *Throbbing in Temples*
- *Muscular Twitching*
- *Vomiting*
- *Inability to Think Coherently*

IF YOU OR ANYONE ELSE EXPERIENCE ANY OF THESE SYMPTOMS, GET OUT INTO THE FRESH AIR IMMEDIATELY. *If symptoms persist, seek medical attention. Shut down the unit and do not operate until it has been inspected and repaired.*

Protection against carbon monoxide inhalation includes proper installation, ventilation and regular, frequent visual and audible inspections of the complete exhaust system.

General Information

INTRODUCTION

This manual deals with specific mechanical and electrical information needed by engine mechanics for troubleshooting, servicing, repairing, or overhauling the engine.

Use the separate PARTS MANUAL for parts identification and for establishing their proper location on assemblies. The PARTS MANUAL contains detailed exploded views of each assembly and the individual piece part numbers and their proper names for ordering replacement parts.

The illustrations and procedures presented in each section apply to the engines listed on the cover. The flywheel-blower end of the engine is the front end so right and left sides are determined by viewing the engine from the front. The No. 1 cylinder is on the left, No. 2 cylinder is on the right.

If a major repair or an overhaul is necessary, a competent mechanic should either do the job or supervise and check the work of the mechanic assigned to the job to ensure that all dimensions, clearances and torque values are within the specified tolerances.

Use the table of contents for a quick reference to the separate engine system sections.

The troubleshooting guide is provided as a quick reference for locating and correcting engine trouble.

The wiring diagram shows how the electrical components are interconnected.

The disassembly section contains major overhaul procedures for step by step removal, disassembly, inspection, repair, and assembly of the engine components.

See the Operator's Manual for fuel and engine oil recommendations and the Periodic Maintenance Schedule.

Use only Genuine Onan replacement parts to ensure quality and the best possible repair and overhaul results. When ordering parts, always use the complete model and spec number as well as the serial number shown on the nameplate.

ENGINE MODEL REFERENCE

Identify your model by referring to the model and specification (spec letter) as shown on the unit nameplate. Always use these numbers and the engine serial number when making reference to your engine.

How to interpret MODEL and SPEC NO.

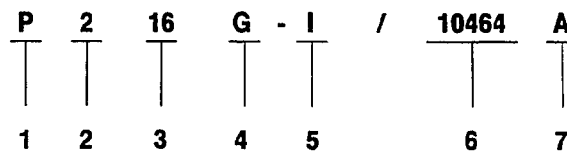

1. Factory code for general identification of basic engine series.
2. Number of cylinders.
3. BHP rating.
4. Fuel required (G = horizontal shaft, V = vertical shaft).
5. Engine duty cycle.
6. Factory code for designated optional equipment, if any.
7. Specification (spec letter) which advances with factory production modifications.

▲WARNING

INCORRECT SERVICE OR REPLACEMENT OF PARTS CAN RESULT IN SEVERE PERSONAL INJURY AND/OR EQUIPMENT DAMAGE. SERVICE PERSONNEL MUST BE QUALIFIED TO PERFORM ELECTRICAL AND/OR MECHANICAL SERVICE.

Specifications

This manual contains SI metric equivalents that follow immediately in parentheses after the U.S. customary units of measure.

SPECIFICATION	UNIT OF MEASURE	SERIES			
		P216	P218	P220	P224
Number of Cylinders		2	2	2	2
Bore	in (mm)	3.250 (82.55)	3.250 (82.55)	3.250 (82.55)	3.560 (90.42)
Stroke	in (mm)	2.625 (66.68)	2.875 (73.03)	2.875 (73.03)	3.000 (76.20)
Displacement	cu in (cm ³)	43.3 (710)	47.7 (782)	47.7 (782)	59.7 (983)
Compression Ratio		6.5 to 1	7.0 to 1	7.0 to 1	7.0 to 1
Rated Speed (Maximum)	RPM	3600	3600	3600	3600
Power at Rated Speed	BHP (kW)	16 (11.9)	18 (13.4)	20 (14.9)	24 (17.9)
Oil Capacity*					
Standard Base Without Filter	Qts (litre)	1.5 (1.4)	1.5 (1.4)	1.5 (1.4)	1.5 (1.4)
Medium Capacity Base Without Filter	Qts (litre)	2.2 (2.1)	2.2 (2.1)	2.2 (2.1)	2.2 (2.1)
High Capacity Base Without Filter	Qts (litre)	2.7 (2.6)	2.7 (2.6)	2.7 (2.6)	2.7 (2.6)
Oil Filter Capacity	Qts (litre)	.3 (.3)	.3 (.3)	.3 (.3)	.3 (.3)
Crankshaft Rotation (viewed from flywheel)		Clockwise	Clockwise	Clockwise	Clockwise
Valve Clearance (Cold)					
Intake	in (mm)	.005 (.13)	.005 (.13)	.005 (.13)	.005 (.13)
Exhaust	in (mm)	.013 (.33)	.013 (.33)	.013 (.33)	.013 (.33)
Spark Plug Gap	in (mm)	.025 (.64)	.025 (.64)	.025 (.64)	.025 (.64)
Ignition Timing	BTC	20°	20°	20°	20°
Cylinder Compression	psi (kPa)	75 to 115 (517 to 793)	75 to 115 (517 to 793)	75 to 115 (517 to 793)	75 to 115 (517 to 793)

* - Refer to *MAINTENANCE* section.

Dimensions and Clearances

P216, P218, P220

All clearances given at room temperature of 70°F. (21°C). All dimensions in inches (approximate millimeter dimensions in parentheses) unless otherwise specified.

DESCRIPTION	MINIMUM		MAXIMUM	
	Inches	(mm)	Inches	(mm)
CYLINDER BLOCK				
Cylinder Bore Honed Diameter	3.2490	(82.52)	3.2500	(82.55)
Maximum Allowable				
Taper			0.005	(0.13)
Out-of-Round			0.003	(0.08)
Main Bearing Inside Diameter (Without bearing)	2.1870	(55.55)	2.1880	(55.58)
Main Bearing Inside Diameter (Installed service bearing)	2.0015	(50.84)	2.0040	(50.90)
Camshaft Bearing Bore (Installed service bearing)	1.3757	(34.94)	1.3787	(35.02)
CRANKSHAFT				
Main Bearing Journal Diameter	1.9992	(50.78)	2.0000	(50.80)
Main Bearing Clearance	0.0024	(0.061)	0.0042	(0.107)
Connecting Rod Journal Diameter	1.6252	(41.28)	1.6260	(41.30)
Crankshaft End Play	0.0060	(0.152)	0.0120	(0.305)
CONNECTING ROD				
Large Bore Diameter (Rod bolts properly torqued)	1.6280	(41.35)	1.6285	(41.36)
End Play	0.0020	(0.051)	0.0160	(0.406)
Piston Pin Bushing Bore (Finished bore)	0.6879	(17.47)	0.6882	(17.48)
Bearing to Crankshaft Clearance.....	0.0020	(0.051)	0.0033	(0.084)
CAMSHAFT				
Bearing Journal Diameter	1.3740	(34.90)	1.3745	(34.91)
Bearing Clearance	0.0015	(0.038)	0.0030	(0.076)
End Play	0.0110	(0.279)	0.0480	(1.219)
Lobe Height				
P216, P218 Intake		1.1370	(28.88)	
P216, P218 Exhaust		1.1570	(29.39)	
P220 Intake.....		1.1670	(29.64)	
P220 Exhaust.....		1.1570	(29.39)	
PISTON				
Clearance in Cylinder				
Measure 90° to pin 1.187 inch below top of piston	0.0033	(0.084)	0.0053	(0.135)
Piston Pin Bore	0.6877	(17.47)	0.6882	(17.48)
Ring Groove Width				
Top Compression Ring	0.0800	(2.032)	0.0810	(2.057)
Middle Compression Ring.....	0.0800	(2.032)	0.0810	(2.057)
Bottom Oil Control Ring	0.1880	(4.775)	0.1890	(4.800)

P216, P218, P220

DESCRIPTION	MINIMUM		MAXIMUM	
	Inches	(mm)	Inches	(mm)
PISTON PIN				
Clearance in Piston	0.00004	(0.001)	0.00064	(0.016)
Clearance in Connecting Rod	0.0002	(0.005)	0.0007	(0.018)
Diameter	0.6875	(17.46)	0.6877	(17.47)
PISTON RINGS				
Clearance				
Top Groove	0.0030	(0.076)	0.0080	(0.203)
Ring End Gap in Cylinder	0.0100	(0.254)	0.0200	(0.508)
INTAKE VALVE				
Stem Diameter	0.2795	(7.099)	0.2800	(7.112)
Clearance (Stem to Guide)	0.0010	(0.025)	0.0025	(0.064)
Valve Face Angle			44°	
INTAKE VALVE SEAT				
Seat Bore Diameter in Block	1.4395	(36.56)	1.4405	(36.59)
Seat Outside Diameter	1.443	(36.65)	1.444	(36.68)
Valve Seat Width	0.0310	(0.787)	0.0470	(1.194)
Valve Seat Angle			45°	
EXHAUST VALVE				
Stem Diameter	0.2780	(7.061)	0.2785	(7.074)
Clearance (Stem to Guide)	0.0020	(0.051)	0.0035	(0.089)
Valve Face Angle			44°	
EXHAUST VALVE SEAT				
Seat Bore Diameter in Block	1.1890	(30.20)	1.1900	(30.23)
Seat Outside Diameter	1.1920	(30.28)	1.1930	(30.30)
Valve Seat Width	0.0310	(0.787)	0.0470	(1.194)
Valve Seat Angle			45°	
VALVE GUIDE				
Intake Inside Diameter	0.2810	(7.137)	0.2820	(7.163)
Exhaust Inside Diameter	0.2805	(7.125)	0.2815	(7.150)
TAPPET				
Body Diameter	0.7475	(18.99)	0.7480	(19.00)
Bore Diameter	0.7500	(19.05)	0.7515	(19.09)
Clearance in Bore	0.0020	(0.051)	0.0040	(0.102)
VALVE SPRINGS INTAKE AND EXHAUST				
Valve Spring Free Length (Approx.)		1.600	(40.64)	
Valve Spring Length				
Valve Open		1.055	(26.80)	
Valve Closed		1.346	(34.19)	
Spring Load (Valve Open Length)		55 lb.	(25 kg)	
Spring Load (Valve Closed Length)		25 lb.	(11 kg)	
GEAR BACKLASH				
Timing Gear	0.0010	(0.025)	0.0050	(0.127)
Oil Pump Gear	0.0010	(0.025)	0.0080	(0.203)

P224

DESCRIPTION	MINIMUM		MAXIMUM	
	Inches	(mm)	Inches	(mm)
CYLINDER BLOCK				
Cylinder Bore Honed Diameter	3.5625	(90.49)	3.5635	(90.51)
Maximum Allowable				
Taper			0.003	(0.08)
Out-of-Round			0.003	(0.08)
Main Bearing Inside Diameter (Without bearing)	2.1870	(55.55)	2.1880	(55.58)
Main Bearing Inside Diameter (Installed)	2.0015	(50.84)	2.0040	(50.90)
Camshaft Bearing Bore (Bearing Installed)	1.3757	(34.94)	1.3787	(35.02)
CRANKSHAFT				
Main Bearing Journal Diameter	1.9992	(50.78)	2.0000	(50.80)
Main Bearing Clearance	0.0024	(0.061)	0.0042	(0.107)
Connecting Rod Journal Diameter	1.6252	(41.28)	1.6260	(41.30)
Crankshaft End Play	0.0060	(0.152)	0.0120	(0.305)
CONNECTING ROD				
Large Bore Diameter (Without bearing installed and rod bolts properly torqued)	1.7505	(44.46)	1.7510	(44.48)
Connecting Rod Side Clearance	0.0020	(0.051)	0.0160	(0.406)
Piston Pin Bushing Bore (Without bushing)	0.8115	(20.61)	0.8125	(20.64)
Piston Pin Bushing Bore (Finished bore)	0.7504	(19.06)	0.7508	(19.07)
Bearing to Crankshaft Clearance	0.0020	(0.051)	0.0033	(0.084)
CAMSHAFT				
Bearing Journal Diameter	1.3740	(34.90)	1.3745	(34.91)
Bearing Clearance	0.0015	(0.038)	0.0030	(0.076)
End Play	0.0110	(0.279)	0.0480	(1.219)
Lobe Height				
Intake		1.1670	(29.64)	
Exhaust		1.1570	(29.39)	
PISTON				
Clearance in Cylinder				
Measure 90° to pin 1.187 inch below top of piston	0.0070	(0.178)	0.0090	(0.229)
Piston Pin Bore	0.7502	(19.06)	0.7506	(19.07)
Ring Groove Width				
Top Compression Ring	0.0800	(2.032)	0.0810	(2.057)
Middle Compression Ring	0.0800	(2.032)	0.0810	(2.057)
Bottom Oil Control Ring	0.1880	(4.775)	0.1890	(4.801)
PISTON PIN				
Clearance in Piston	0.00004	(0.001)	0.00064	(0.016)
Clearance in Connecting Rod	0.0002	(0.005)	0.0008	(0.020)
Diameter	0.7500	(19.05)	0.7502	(19.06)
PISTON RINGS				
Clearance				
Top Groove	0.0020	(0.051)	0.0080	(0.203)
Ring End Gap in Cylinder	0.0100	(0.254)	0.0200	(0.508)

P224

DESCRIPTION	MINIMUM		MAXIMUM	
	Inches	(mm)	Inches	(mm)
INTAKE VALVE				
Stem Diameter	0.3425	(8.700)	0.3430	(8.712)
Clearance (Stem to Guide)	0.0010	(0.025)	0.0025	(0.064)
Valve Face Angle			44°	
INTAKE VALVE SEAT				
Seat Cylinder Head Bore Diameter	1.5645	(39.74)	1.5655	(39.76)
Seat Outside Diameter	1.5690	(39.85)	1.5700	(39.88)
Valve Seat Width	0.0310	(0.787)	0.0470	(1.194)
Valve Seat Angle			45°	
EXHAUST VALVE				
Stem Diameter	0.3410	(8.661)	0.3420	(8.687)
Clearance (Stem to Guide)	0.0025	(0.064)	0.0040	(0.102)
Valve Face Angle			44°	
EXHAUST VALVE SEAT				
Seat Cylinder Head Bore Diameter	1.2510	(31.78)	1.2520	(31.80)
Seat Outside Diameter	1.2550	(31.88)	1.2560	(31.90)
Valve Seat Width	0.0310	(0.787)	0.0470	(1.194)
Valve Seat Angle			45°	
VALVE GUIDE				
Intake Inside Diameter	0.3440	(8.738)	0.3460	(8.788)
Exhaust Inside Diameter	0.3440	(8.738)	0.3460	(8.788)
TAPPET				
Body Diameter	0.7475	(18.99)	0.7480	(19.00)
Bore Diameter	0.7500	(19.05)	0.7515	(19.09)
Clearance in Bore	0.0020	(0.051)	0.0040	(0.102)
VALVE SPRINGS INTAKE AND EXHAUST				
Valve Spring Free Length (Approx.)		1.662	(42.21)	
Valve Spring Length				
Valve Open		1.125	(28.58)	
Valve Closed		1.375	(34.93)	
Spring Load (Valve Open Length)		71 lb.	(32 kg)	
Spring Load (Valve Closed Length)		38 lb.	(17 kg)	
GEAR BACKLASH				
Timing Gear	0.0010	(0.025)	0.0050	(0.127)
Oil Pump Gear	0.0010	(0.025)	0.0080	(0.203)

Assembly Torques

The torque values given in Table 1 have been determined for specific applications. Standard torque values must not be used where those listed in Table 1 apply. The engine assembly torques given here will assure proper tightness without danger of stripping threads. All threads must be clean and lubricated with new engine oil before torquing.

Tighten all studs, nuts, and capscrews as required to keep them from working loose. Refer to the *PARTS MANUAL* for the location of washers and capscrews.

TABLE 1.

P216, P218, P220 DESCRIPTION	TORQUE SPECIFICATION		P216, P218, P220 DESCRIPTION	TORQUE SPECIFICATION	
	Ft.-Lb.	Nm		Ft.-Lb.	Nm
Gearcase Cover	8-10	11-14	Intake Manifold Mounting Screws	6-10	8-14
Rear Bearing Plate Screws	25-27	34-37	Exhaust Manifold Mounting Screws	9-11	12-15
Starter Mounting Bolts	19-21	25-28	Other 1/4" Cylinder Block Stud and Nuts	7-9	10-12
Connecting Rod Bolts	12-14	16-19	Other 5/16" Cylinder Block Stud and Nuts	8-10	11-14
Flywheel Capscrews	50-55	67-75	Other 3/8" Cylinder Block Stud and Nuts	18-23	24-31
Oil Base	18-23	24-31			
Oil Pump	7-9	10-12			
Valve Cover	1-2	1-3			
Cylinder Head Bolts (Cold)					
Asbestos Gasket	16-18	22-24			
Graphoil Gasket	14-16	19-22			

P224 DESCRIPTION	TORQUE SPECIFICATION		P224 DESCRIPTION	TORQUE SPECIFICATION	
	Ft.-Lb.	Nm		Ft.-Lb.	Nm
Gearcase Cover	8-10	11-14	Intake Manifold Mounting Screws	20-23	27-31
Rear Bearing Plate Screws	25-27	34-37	Exhaust Manifold Mounting Screws	9-11	12-15
Starter Mounting Bolts	19-21	25-28	Other 1/4" Cylinder Block Stud and Nuts	7-9	10-12
Connecting Rod Bolts	27-29	37-39	Other 5/16" Cylinder Block Stud and Nuts	8-10	11-14
Flywheel Capscrews	50-55	67-75	Other 3/8" Cylinder Block Stud and Nuts	18-23	24-31
Oil Base	18-23	24-31			
Oil Pump	7-9	10-12			
Valve Cover	4-8	5-11			
Cylinder Head Nuts (Cold)					
(w/Compression Washers)	14	19			
(w/o Compression Washers) ..	17	23			

Special Tools

The following special tools are available from Onan. For further information see *TOOL CATALOG 900-0019*.

- Valve Seat Driver
- Valve Guide Driver
- Oil Seal Guide and Driver
- Combination Bearing Remover (Main and Cam)
- Combination Bearing Driver (Main and Cam)
- Flywheel Puller

Engine Troubleshooting

another free manual from www.searstractormanuals.com

TROUBLE															GASOLINE ENGINE TROUBLESHOOTING GUIDE																				
Backfire at Carburetor	Bearing Wear	Black Exhaust	Blue Exhaust	Burned Valves	Connecting Rod Wear	Crankshaft Slowly	Cylinder Wear	Engine Stops	Failure to Start	Governor Hunting	High Oil Pressure	Low Oil Pressure	Loss of Coolant (Water Cooled)	Mechanical Knocks	Missing	Overheating (Air Cooled)	Piston Wear	Poor Compression	Ring Wear	Sticking Valves	CAUSE														
															STARTING SYSTEM																				
															Loose or Corroded Battery Connection																				
															Low or Discharged Battery																				
															Faulty Starter																				
															Faulty Start Solenoid																				
															IGNITION SYSTEM																				
															Ignition Timing Wrong																				
															Wrong Spark Plug Gap																				
															Bad Ignition Coil																				
															Faulty Spark Plug Wires																				
															Bad Ignition Module or Trigger Ring																				
															FUEL SYSTEM																				
															Out of Fuel - Check																				
															Lean Fuel Mixture																				
															Rich Fuel Mixture or Choke Stuck																				
															Engine Flooded																				
															Poor Quality Fuel																				
															Dirty Carburetor																				
															Dirty Air Cleaner																				
															Dirty Fuel Filter																				
															Defective Fuel Pump																				
															INTERNAL ENGINE																				
															Wrong Valve Clearance																				
															Broken Valve Spring																				
															Valve or Valve Seal Leaking																				
															Piston Rings Worn or Broken																				
															Wrong Bearing Clearance																				
															COOLING SYSTEM (AIR COOLED)																				
															Poor Air Circulation																				
															Dirty or Oily Cooling Fins																				
															Blown Head Gasket																				
															LUBRICATION SYSTEM																				
															Defective Oil Gauge																				
															Relief Valve Stuck																				
															Faulty Oil Pump																				
															Dirty Oil or Filter																				
															Oil Too Light or Diluted																				
															Oil Level Low																				
															Oil Too Heavy																				
															Dirty Crankcase Breather Valve																				
															THROTTLE AND GOVERNOR																				
															Linkage Out of Adjustment																				
															Linkage Worn or Disconnected																				
															Governor Spring Sensitivity Too Great																				
															Linkage Binding																				

Oil System

CRANKCASE OIL

Refer to *Periodic Maintenance Schedule* (located in the Operator's Manual) for oil change interval. If operating in extremely dusty, high ambient, or low ambient conditions, change oil more often.

⚠ WARNING *Hot crankcase oil can cause burns if it comes in contact with skin. Wear protective clothing and keep fingers and hands clear when draining oil.*

⚠ CAUTION *Excess oil can cause high oil consumption, high operating temperatures, and oil foaming. Do not overfill crankcase.*

Run engine until thoroughly warm before draining oil. Stop the engine, place a pan under the drain outlet and remove the oil drain plug. After the oil is completely drained, clean and replace the drain plug. Fill crankcase with correct amount of oil. Refer to *SPECIFICATIONS* for crankcase capacity. Use oils meeting the API classification SF, SF/CC, or SF/CD. Refer to chart to determine the proper viscosity grade of oil to use. Straight weight oils are recommended for severe duty use and at temperatures above 32°F (0°C) for minimum oil consumption.

⚠ WARNING *Crankcase pressure can blow out hot oil, which can cause severe personal injury. Do not check oil while the engine is running.*

Oil level should be to the FULL mark of the dipstick. Start engine and run for a short time to check for oil leaks around the drain plug.

USE THESE SAE VISCOSITY GRADES

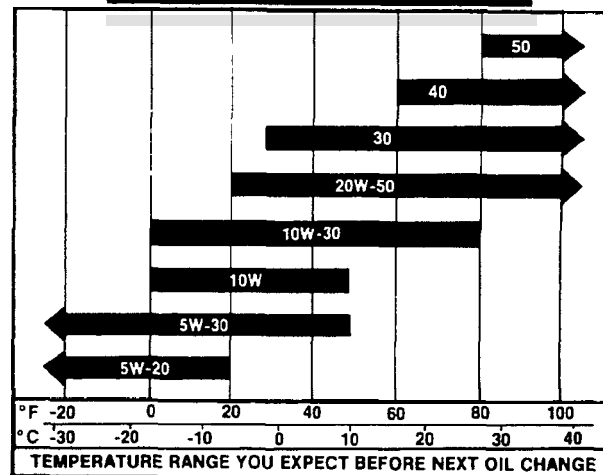

LS-1170

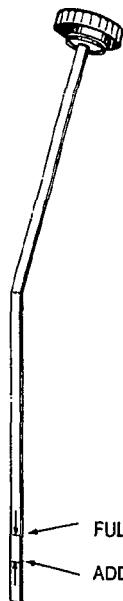

ALWAYS REPLACE
TIGHTLY OR OIL
LEAKAGE MAY OCCUR

FULL - CAUTION: DO NOT OVERFILL
ADD - REFER TO AMOUNT ON DIPSTICK

C-1000

FIGURE 1. CRANKCASE OIL FILL

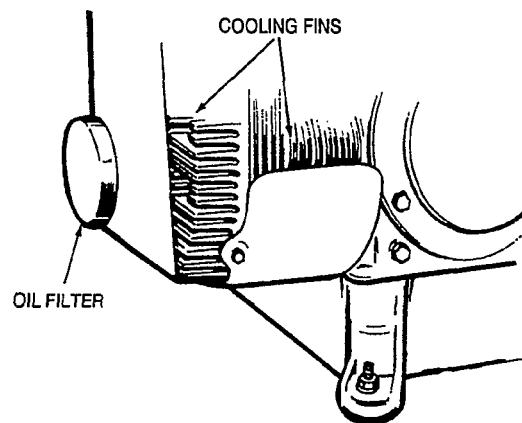

FIGURE 2. OIL FILTER

C-1001

OIL FILTER CHANGE

Refer to *Periodic Maintenance Schedule* (located in the Operator's Manual) for oil filter change interval. If operating in extremely dusty, high ambient, or low ambient conditions, change oil filter more often.

Spin off oil filter element and discard it. Thoroughly clean filter mounting surface and make sure new gasket is inserted in the element. Apply a thin film of clean oil to the gasket. Spin element down by hand until gasket just touches mounting pad and then turn down an additional 1/2-3/4 turn. Do not overtighten.

With oil in crankcase, start engine and check for leaks around filter element. Retighten only as much as necessary to eliminate leaks; do not overtighten.

CRANKCASE BREATHER

The crankcase breather prevents pressure from building up in the crankcase. It also prevents oil contamination by removing moisture or gasoline vapors and other harmful blow-by materials from the crankcase. These vapors are routed to the carburetor where they are mixed with incoming air and burned in the combustion chamber. A sticky breather valve can cause oil leaks, high oil consumption, rough idle, reduced engine power, and a rapid formation of sludge and varnish within the engine.

Crankcase Breather Service

If the crankcase becomes pressurized as evidenced by oil leaks at the seals or excessive oil in the air cleaner housing, use the following procedure to service.

▲WARNING *Most parts cleaning solvents are flammable and can cause severe personal injury or death if used improperly. Follow the manufacturer's recommendations when cleaning parts.*

P216, P218, P220 (Spec A and B)

Remove the breather tube from the valve cover (Figure 3A). Remove capscrew, flatwashers, valve cover, pack, spring, washer, reed valve, and breather baffle. Discard gasket and clean all parts in part cleaning solvent.

▲CAUTION *Overtightening the valve cover can cause engine damage. Do not overtighten valve cover.*

The reed valve must be flat with no sign of a crease. Assemble using a new gasket. Refer to *ASSEMBLY TORQUES* for valve cover capscrew torque specification.

P216, P218, P220 (Beginning Spec C)

The crankcase breather does not require servicing. Replace breather if it's broken or cracked or if crankcase becomes pressurized as evidenced by oil leaks at the seals or excessive oil in the air cleaning housing.

P224

Remove the breather hose from cap and valve assembly. Remove cap and valve assembly and wash in a suitable solvent. Replace cap and valve if balls do not move freely. Pull pack out and wash in solvent. To allow free operation of the valve, screens must be positioned as shown in Figure 3B.

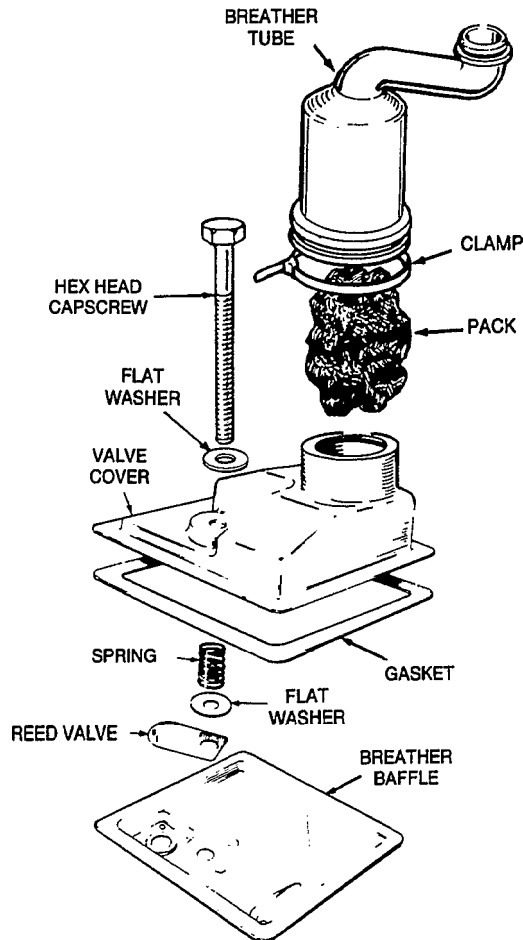

C-1003

FIGURE 3A. CRANKCASE BREATHER - P216, P218, P220

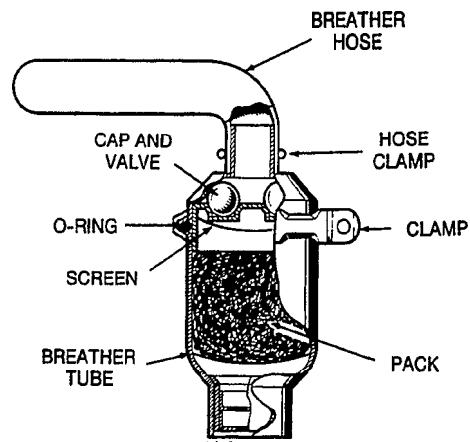

FIGURE 3B. CRANKCASE BREATHER - P224

PRESSURE LUBRICATION

All engines use an oil pump to provide a constant flow of oil to the engine parts. The oil supply collects in the oil base where it is picked up by the oil pump pick-up cup. A by-pass valve is used to control oil pressure. Drain oil before removing oil base and always use a new gasket when replacing the oil base.

Oil Pump

The oil pump (Figure 4) is mounted behind the gear cover and is driven by the crankshaft gear. Inlet pipe and screen assembly are attached directly to the pump body. A discharge passage in pump cover registers with a drilled passage in the crankcase. Parallel passages distribute oil to the front and rear main bearing and the oil bypass valve.

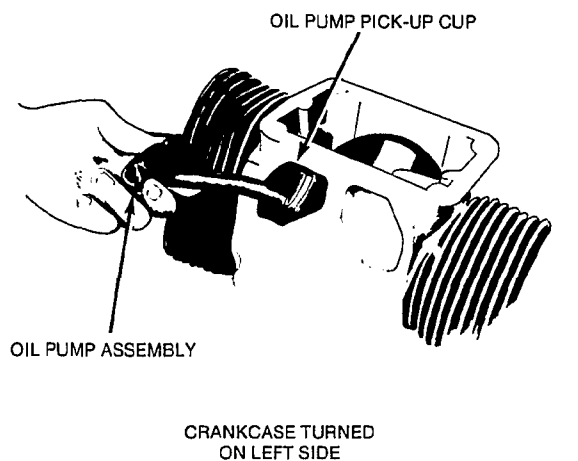

FIGURE 4. OIL PUMP ASSEMBLY

Circumferential grooves in the main bearings supply oil to connecting rod bearings through drilled passages from each main journal. A drilled passage connects the front main bearing oil supply to the front camshaft bearing; rear cam bearing is splash lubricated.

Normal oil pressure should be 8 psi (55 kPa) or higher at 1500 rpm when the engine is at normal operating temperature. If pressure at 1500 rpm drops below this value, inspect oil system for faulty components.

Check oil pump thoroughly for worn parts. Oil pump to prime it before reinstalling. Except for gaskets and pick-up cup, component parts of the pump are not available individually. Install a new pump assembly if any parts are worn.

Oil By-Pass Valve

The by-pass valve (located to the right and behind gear cover) controls oil pressure by allowing excess oil to flow directly back to the crankcase. The valve limits oil pressure to a maximum of about 20 psi (138 kPa) on the P216, P218, and P220, and about 30 psi (207 kPa) on the P224 at normal operating temperature.

The valve is non-adjustable and normally does not need maintenance. Determine if valve is operating correctly by inspecting plunger action as follows:

1. Remove the cap screw located behind gear cover and under governor arm.
2. Remove spring and plunger with a magnetic tool.
3. Determine proper valve operation by checking the spring and plunger according to the following measurements:

Plunger Diameter 0.3105 to 0.3125 in.
(7.89 to 7.94 mm)

Spring
Free Length 1.00 inch (25.4 mm)
Load 2.6 ± 0.2 lbs (11.6 ± 0.9 N)
when compressed to 0.5 inch (12.7 mm)

4. Check the valve seat and clean away any accumulation of metal particles which could cause erratic valve action. Verify that the valve seat is not damaged.
5. Clean plunger and spring in parts cleaning solvent and install.

Fuel System

CARBURETOR

(Does not Apply to Spec G and Later)

All carburetors have a fixed main jet. An optional fixed main jet is available for altitude compensation above 5,000 feet.

The carburetor idle mixture was set for maximum efficiency at the factory and should normally not be disturbed. If adjustments seem necessary, first be sure the ignition system is working properly and governor sensitivity is properly adjusted.

The carburetor has a limited adjustment range between stops of $\pm 1/8$ turn. The screw should only be adjusted within these limits; in to lean the mixture, out to richen.

CAUTION Overtightening the mixture adjustment screw will cause carburetor damage. Turn mixture adjustment screw in only until light tension can be felt.

If replacing idle mixture screw, turn in until lightly seated, then turn screw back out 1-1/4 turns for the P216, P218, and P220 carburetors, and 1-1/2 turns for the P224 carburetor. Replace limiter cap with the plastic stop approximately centered.

Carburetor Speed Settings

1. Start the engine and allow it to warm up thoroughly (at least 10 minutes).

Some equipment manufacturers may require higher throttle stop speed and governor low speed rpm settings. Refer to equipment manufacturer's Operator's Manual for the correct rpm settings. When rpm settings are not specified by the equipment manufacturer, use the rpm settings listed in Steps 2 and 3.

2. Move the engine speed control to the slow position. Bend or turn the low speed stop on the governor so the throttle stop screw on the carburetor controls engine speed. Adjust the throttle stop screw for 1000 rpm idle (Figures 1 and 2).
3. Adjust the governor low speed stop for 1100 rpm idle.
4. Move the engine speed control to the fast position. Bend the high speed stop on the governor so the engine runs at the equipment manufacturer's recommended speed.

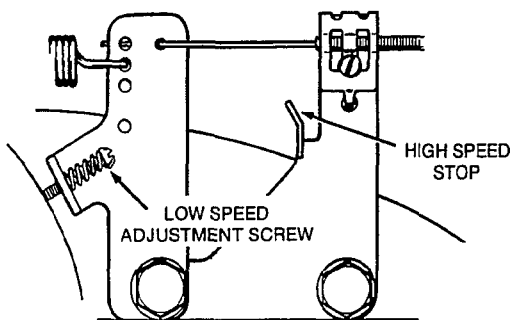

SIDE PULL GOVERNOR ASSEMBLY

FS-1000

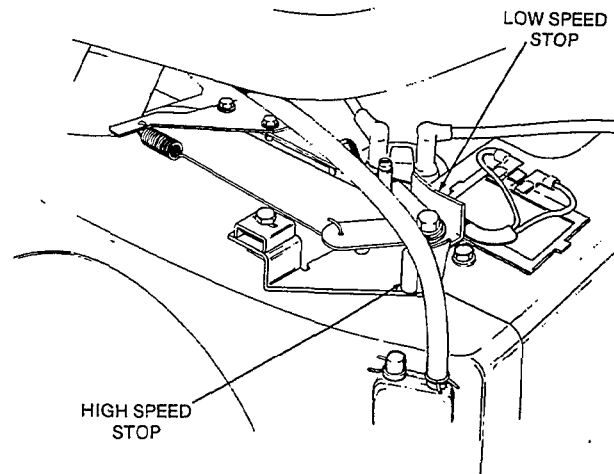

FRONT PULL GOVERNOR ASSEMBLY

M-1396-1

FIGURE 1. GOVERNOR SPEED ADJUSTMENT

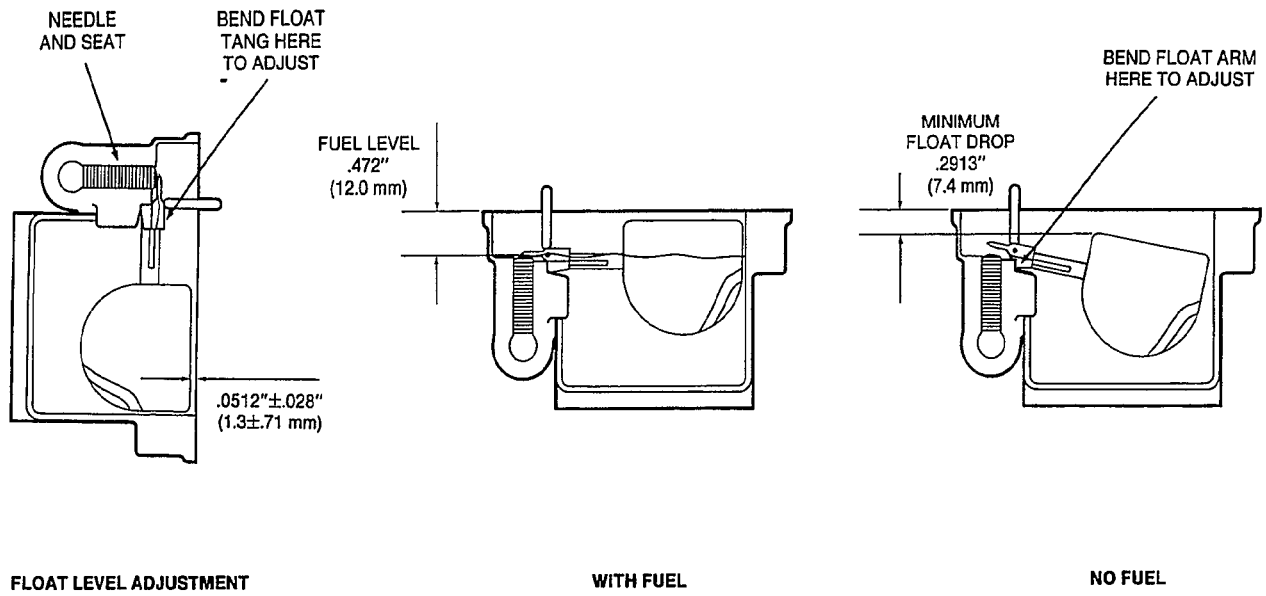

When checking float level and float drop, measure to float body, not seam.

FS-1683

FIGURE 4. CARBURETOR FLOAT LEVEL ADJUSTMENTS

Cleaning and Repair

1. Soak all metal components not replaced in carburetor cleaner. Do not soak non-metal floats or other non-metal parts. Follow the cleaning manufacturer's recommendations.
2. Clean all carbon from the carburetor bore, especially where the throttle and choke plates seat. Be careful not to plug the idle or main fuel ports.
3. Dry out all passages with low pressure air (35 PSI). Avoid using wire or other objects for cleaning which may increase the size of critical passages.
4. Check the condition of the adjustment needle; replace if damaged. Replace float if loaded with fuel or damaged.
5. Check the choke and throttle shafts for excessive play in their bore. This condition may necessitate replacement of the carburetor.
6. Replace old components with new parts.

Reassembly and Installation

1. Install needle valve, main jet, and float assembly. Make sure float pivot pin is properly placed and float moves freely without binding.
2. Turn carburetor on its side and measure float level (Figure 4). Adjust float level only if necessary. Measure float drop (the distance from the top of carburetor body to top of float). Adjust only if necessary.
3. Position gasket on lower carburetor section and install upper carburetor section.
4. Install idle adjustment screw, throttle stop screw, and fixed main jet plug.
5. Mount carburetor on intake manifold and install assembly on engine.
6. Connect governor and throttle linkage, choke control, and fuel line. Mount air cleaner assembly.
7. Adjust carburetor and governor according to directions given in this section.

PULSATING-DIAPHRAGM FUEL PUMP

Pulsating-diaphragm fuel pumps, or pulse pumps, rely on changes in crankcase vacuum to create a pulsating movement of the pump diaphragm. As the engine's pistons move outward, a vacuum is created. This vacuum is transmitted to the pump diaphragm causing it to pull back and suck fuel into the pump. As the engine's pistons move inward, crankcase vacuum is reduced and the diaphragm return spring pushes the pump diaphragm forward, forcing fuel through the pump outlet.

Fuel Pump Test Procedure

Before testing make certain the fuel pump vacuum and fuel line connections are tight and free of leaks.

1. Operate engine at an idle for five minutes to ensure that carburetor is full of fuel.



Ignition of fuel can result in severe personal injury or death. Thoroughly clean up any spilled fuel.

2. Shut engine off and remove fuel inlet line from fuel pump.
3. Connect a vacuum gauge to fuel pump inlet using a piece of fuel hose with clamps.
4. Start engine and allow to idle for at least five seconds. Record vacuum gauge reading.
5. Move throttle control to high idle position. Wait at least five seconds and record vacuum gauge reading.
6. Shut engine off and remove vacuum gauge hose from fuel pump inlet. Connect fuel inlet line to fuel pump.



Ignition of fuel can result in severe personal injury or death. Thoroughly clean up any spilled fuel.

7. Remove fuel outlet line from fuel pump.
8. Connect a pressure gauge to fuel pump outlet using a piece of fuel hose with clamps.
9. Start engine and allow to idle for at least five seconds. While holding pressure gauge level with pump outlet record pressure gauge reading.
10. Move throttle control to high idle position and allow engine to run for at least five seconds. While holding pressure gauge level with pump outlet record pressure gauge reading.
11. Shut engine off and remove pressure gauge hose from fuel pump outlet. Connect fuel outlet line to fuel pump.

Replace the fuel pump if test readings are not within the values specified in TABLE 1.

**TABLE 1
PULSE PUMP TEST SPECIFICATIONS**

ENGINE SPEED	PUMP INLET VACUUM (Minimum)	PUMP OUTLET PRESSURE (Minimum)
Low Idle	2.6 inches of mercury	1.7 psi
High Idle	2.6 inches of mercury	1.7 psi

CARBURETOR (BEGINNING SPEC G)

Carburetor Replacement

Other than replacing the carburetor main fuel jet (fixed-type) with the optional high-altitude jet (Figure 4a), fuel mixture adjustments should not be attempted. Nor should the carburetor be overhauled. Instead, a malfunctioning carburetor should be replaced. Before replacing a carburetor, however, make certain 1) that all other necessary engine and generator adjustments and repairs have been performed and 2) that the carburetor is actually malfunctioning (see *Engine Troubleshooting*).

To remove the carburetor, remove the air cleaner, disconnect the fuel line and choke and throttle linkages and unbolt the carburetor from the intake manifold. When mounting the carburetor always use a new gasket. Readjust the choke and throttle cables and engine speed as instructed in the engine or equipment Operator's Manual.

Carburetor High-Altitude Jet (Optional)

If the engine is operated at an altitude above 5,000 feet (1,524 metres), it is recommended that the carburetor main fuel jet be replaced with the optional high-altitude jet (which has a slightly smaller orifice).

CAUTION To avoid slipping and gouging the main fuel jet, use a screwdriver with a 5/16 inch (8 mm) wide blade.

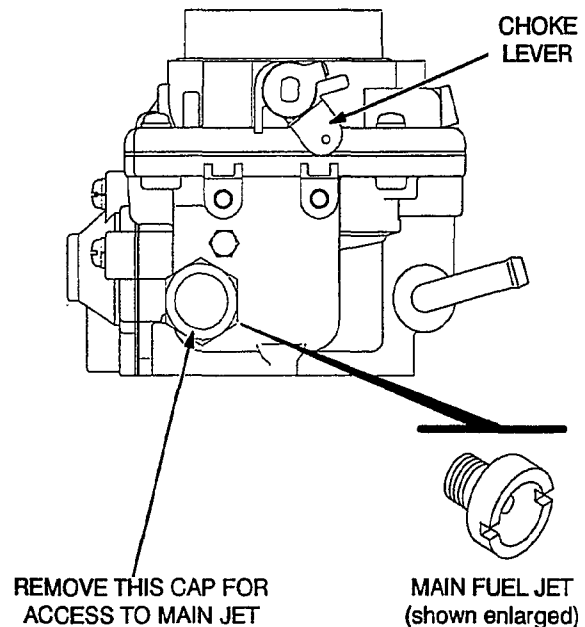
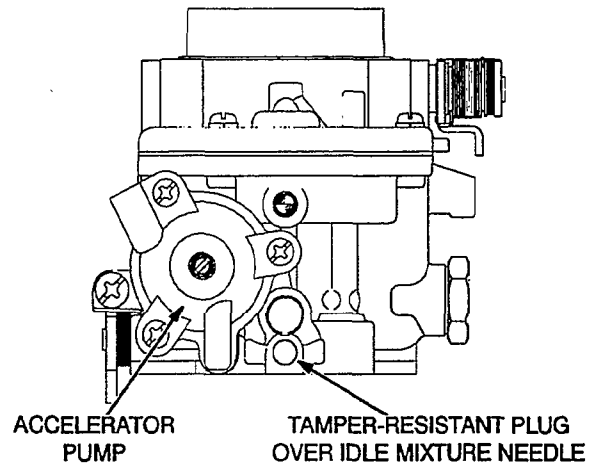
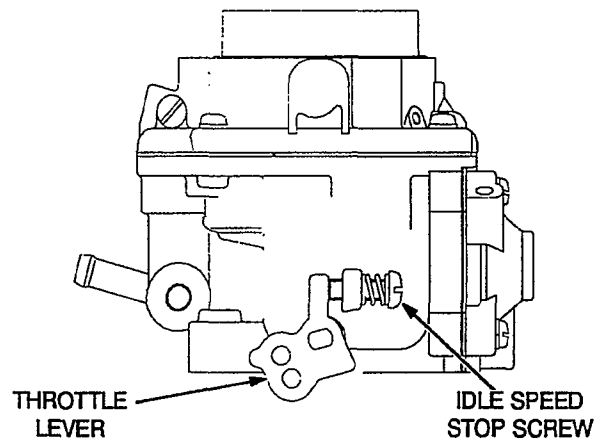
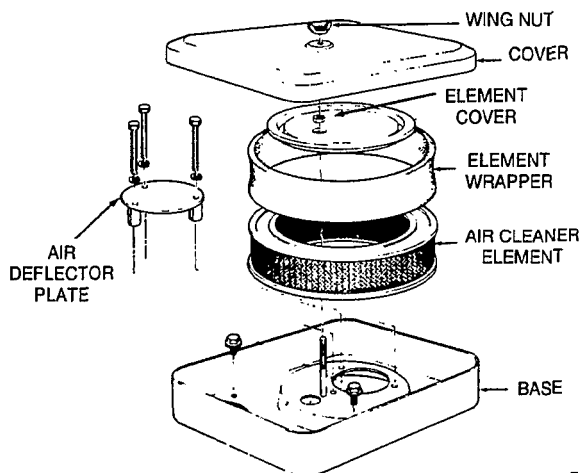

FIGURE 4a. CARBURETOR



FS-1131

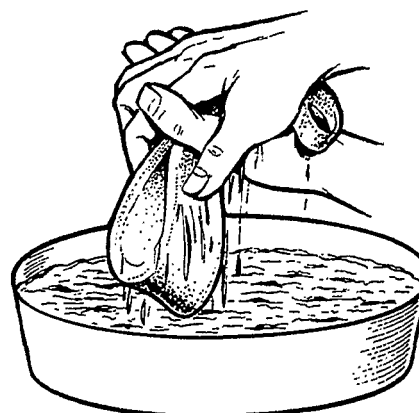

FIGURE 5. AIR CLEANER ASSEMBLY

AIR CLEANER

CAUTION *A dirty air cleaner element can cause engine damage. Ensure air cleaner element is kept clean and free of excess debris.*

CAUTION *Running engine without air cleaner element will result in engine damage. Do not run engine without air cleaner element installed.*

Engine is equipped with a paper element. Refer to *Periodic Maintenance Schedule* (located in the Operator's Manual) for service and replacement intervals. Service by gently tapping element on a flat surface. If engine is equipped with an element wrapper, refer to *Periodic Maintenance Schedule* for service intervals. Service element wrapper as follows:

1. Wash element wrapper in water and detergent (Figure 5). Remove excess water by squeezing like a sponge. Allow wrapper to dry thoroughly.
2. Distribute one tablespoon of SAE 30 engine oil evenly around wrapper. Knead into wrapper and wring out excess oil.

GOVERNOR SENSITIVITY

These engines are adapted for use where a wide range of speed settings is desired. Engine speed is controlled at any given point between minimum and maximum by simply shifting the throttle lever on the control panel until the desired speed is reached.

A reliable instrument for checking engine speed is required for accurate governor adjustment. Engine speed can be checked with a tachometer.

Check the governor arm, linkage, throttle shaft, and lever for binding condition or excessive slack and wear at connecting points. A binding condition at any point will cause the governor to act slowly and regulation will be poor. Excessive looseness may cause a hunting condition and regulation could be erratic. Work the arm back and forth several times by hand while the engine is idling to check for above conditions.

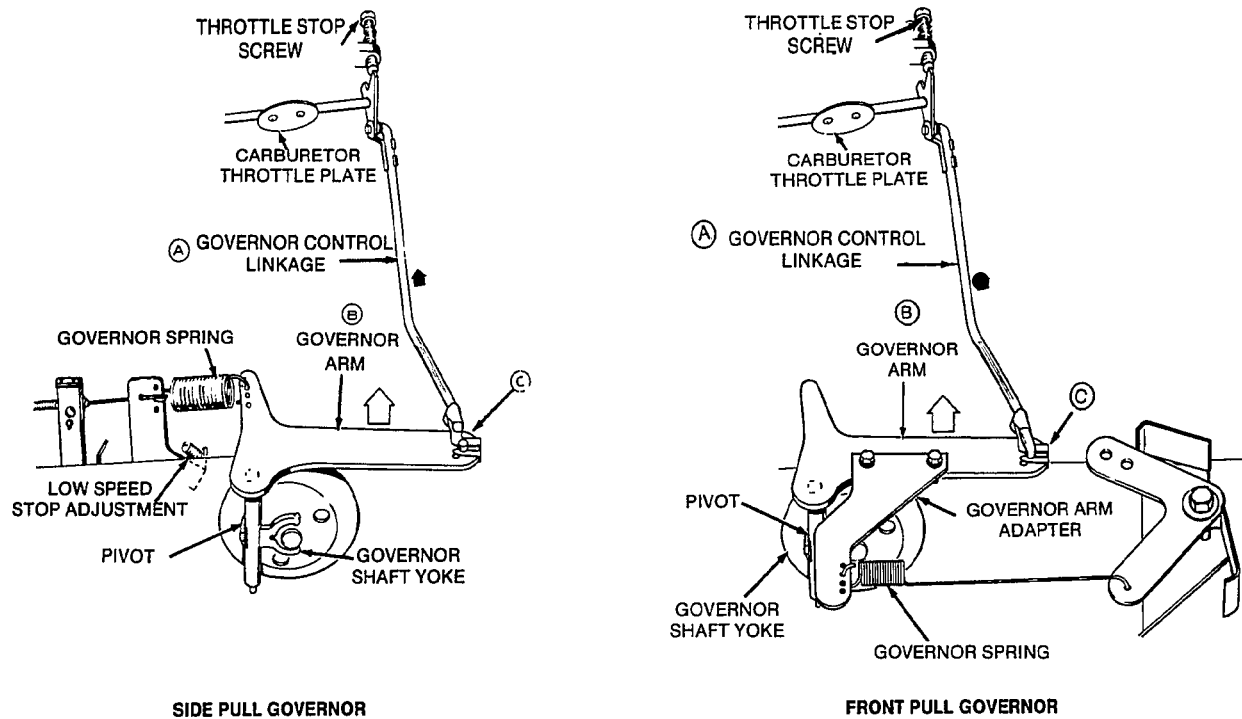

FIGURE 6. VARIABLE SPEED GOVERNOR ADJUSTMENTS

If the governor is hunting or not operating properly, adjust as follows (Figure 6):

1. Disconnect linkage (A) from one of holes (C).
2. Push linkage (A) and governor arm (B) as far back toward carburetor as they will go.
3. Holding linkage and governor arm toward direction of carburetor, insert end of linkage into whichever hole (C) in governor arm lines up the closest. If between two holes, insert in next hole out.

On side pull governors the governor spring is set by the factory in the third hole of the governor arm (third hole from pivot). On front pull governors the governor spring is set by the factory in the second hole of the governor arm adapter (second hole from pivot). To increase sensitivity, move spring loop into a hole closer to the pivot. To decrease sensitivity, move spring loop into a hole farther away from the pivot. After sensitivity has been set, recheck the low speed rpm setting. Adjust if necessary.

Ignition and Battery Charging

IGNITION SYSTEM DESCRIPTION

This engine is equipped with an electronic battery ignition system. Both spark plugs fire simultaneously, thus the need for a distributor is eliminated. The electronic ignition module is located on the engine gear cover behind the flywheel. The module receives a timing signal from magnets within the trigger ring which rotates with the engine crankshaft (Figure 1). If the electronic ignition is suspected of malfunctioning, proceed as follows:

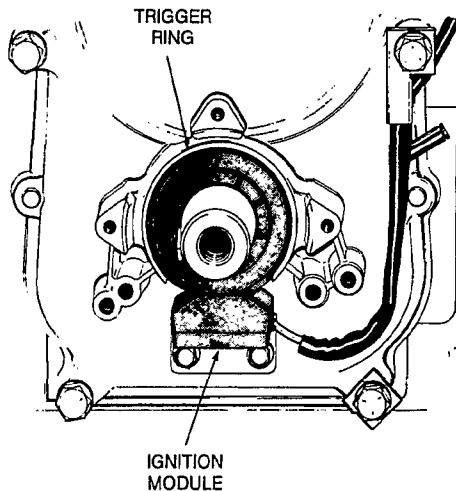

ES-1670

FIGURE 1. IGNITION MODULE AND TRIGGER RING

1. Check all electrical connections to be sure they are clean and tight. If all connections are good and wiring is intact, go to step 2.
2. Refer to IGNITION COIL section to test coil for proper resistance. If coil checks out good, go to step 3.

▲WARNING *The electronic ignition produces current which can cause electrical shock. Do not touch electrical components or wires while ignition is on.*

▲WARNING *Accidental starting of the engine can result in severe personal injury or death. Remove spark plugs before proceeding.*

▲WARNING *Ignition of cylinder gases can cause severe personal injury. Ground spark tester away from spark plug hole.*

3. Pull spark plug wires off spark plugs and remove spark plugs. Connect an approved spark tester to each of the spark plug wires and ground them away from spark plug hole. Turn key on and crank engine over for 5 seconds while watching for spark. If a spark occurs regularly, the problem is not in the ignition system. If no spark occurs, go to step 4.

▲CAUTION *Incorrect wiring can cause electronic ignition damage. Do not attach any lead or jumper with power (such as B+) to coil negative terminal.*

4. Connect a jumper lead directly from the positive battery terminal to the positive (+) coil terminal (smaller diameter of the two threaded posts). Crank engine over while watching for spark. If spark occurs, the problem is in the low oil pressure cut out switch (if equipped) or related wiring, the lubricating system (low oil pressure), or in the other circuitry bringing voltage to the coil. If no spark occurs, go to step 5.

5. Connect positive side of voltmeter to negative (-) coil terminal (larger diameter of the two threaded posts) and negative side of voltmeter to engine ground. Turn key on and rotate flywheel slowly by hand while observing voltmeter. Voltage should switch between battery voltage and 1-1.5 for each revolution. If voltage does not switch properly, replace ignition module.

▲CAUTION *Incorrect wiring can cause electronic ignition damage. Do not attach any lead or jumper with power (such as B+) to coil negative terminal.*

6. Install spark plugs and wires. If ignition module is being replaced, be sure to connect red lead from new ignition module to positive (+) terminal of coil, black lead from module to negative (-) terminal of coil.

IGNITION TIMING

The ignition timing is preset at the factory and is not adjustable. For troubleshooting purposes, it is possible to make an approximate check of the ignition timing using reference marks on the blower housing and flywheel (Figure 2). This check can be performed by a continuity test.

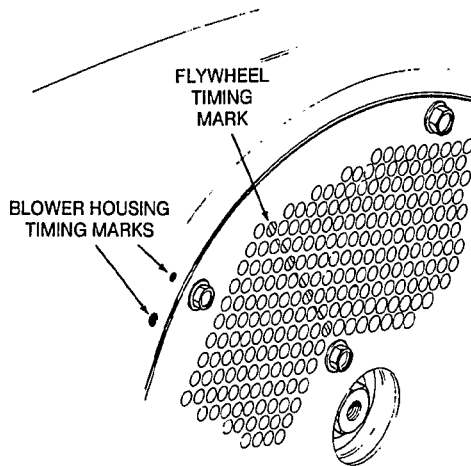

M-1675

FIGURE 2. IGNITION TIMING MARKS

Continuity Test

1. Pull spark plug wires off spark plugs and remove spark plugs.

⚠ WARNING *Accidental starting of the engine can result in severe personal injury or death. Remove spark plugs before proceeding.*

2. Turn ignition on.
3. Connect a voltmeter between the negative (-) coil terminal (larger diameter of the two threaded posts) and a good engine ground.

⚠ WARNING *The electronic ignition produces current which can cause electrical shock. Do not touch electrical components or wires while ignition is on.*

4. Rotate the flywheel slowly by hand in the clockwise direction until the voltmeter reading switches from approximately 1 volt to battery voltage. At this point, one of the chaff screen screws should lie between the two timing marks on the blower housing. To recheck timing, the flywheel must be rotated another complete revolution in the clockwise direction. Moving the flywheel back and forth across the reference timing mark will not activate the electronic ignition control.
5. Install spark plugs and wires.

IGNITION COIL

To test primary and secondary windings within the ignition coil first make sure the ignition power is off and coil is at room temperature of 70°F (21°C).

1. Use a Simpson 260 VOM or equivalent.
2. Place a black lead on negative (-) coil terminal and red lead to positive (+) coil terminal. Primary resistance should read between 2.90-3.60 ohms.
3. Change resistance setting on ohmmeter. Place ohmmeter leads inside of spark plug cable holes (Figure 3). Secondary resistance should read between 14,500-19,800 ohms.
4. If either of the above resistances are not within specification, replace coil.

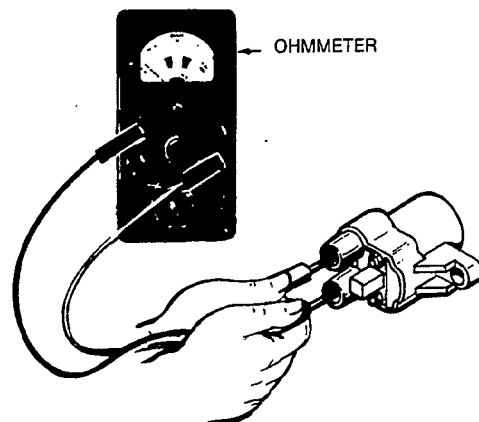

FIGURE 3. COIL TEST

SPARK PLUGS

Check or replace spark plugs as recommended in the *Periodic Maintenance Schedule* (located in Operator's Manual). Replace spark plugs that show signs of fouling or electrode erosion.

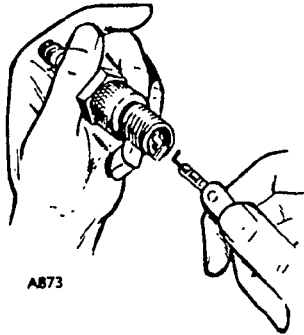

FIGURE 4. SPARK PLUG GAP

BATTERY INSPECTION

⚠WARNING *Ignition of explosive battery gases can result in severe personal injury. Do not smoke or allow any ignition source near the battery.*

Check battery cells with a hydrometer (Figure 5). Specific gravity reading should be between 1.260 and 1.290 at 77°F (25°C).

If one or more cells are low on water, add distilled water and recharge. Keep the battery case clean and dry. An accumulation of moisture or dirt will accelerate discharge and battery failure.

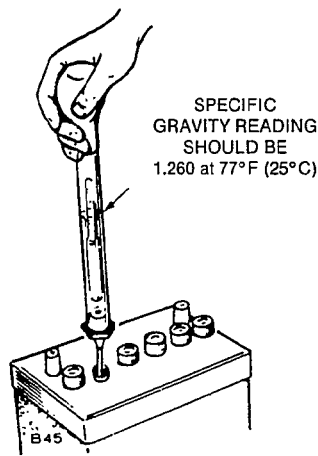

FIGURE 5. SPECIFIC GRAVITY TEST

Keep the battery terminals clean and tight. Push the cable terminal down flush with or slightly below the top of the battery post (Figure 6). After making connections, coat the terminals with a light application of petroleum jelly or grease to retard corrosion.

Poor contact at the battery cable connections is often a source of trouble. Make sure battery cables are in good condition and that contacting surfaces are clean and tightly connected. Do not reverse battery leads. Use recommended battery tools when disconnecting leads to avoid mechanical battery damage.

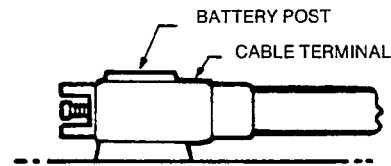

FIGURE 6. BATTERY CABLE CONNECTION

BATTERY JUMP STARTING

Occasionally, it may be necessary to jump start (charge) a weak battery using a charged booster battery. If jump starting is necessary, the following procedure is recommended to prevent starter damage, battery damage, and personal injuries.

1. Disconnect engine load.
2. Use a battery of the same voltage (12V) as is used with your engine.
3. Attach one end of the positive booster cable (red) to the positive (+) terminal of the booster battery. Attach the other end of the positive cable to the positive (+) terminal of your engine battery.

⚠WARNING *Electrical arcing can cause severe personal injury. Do not allow positive and negative cable ends to touch.*

4. Attach one end of the negative booster cable (black) to negative (-) terminal of booster battery. Attach other end of negative cable to a solid chassis ground on your engine.
5. Jump starting in any other manner may result in damage to the battery or the electrical system.

⚠CAUTION *Overcranking the engine can cause starter damage. Allow 5 minutes for starter to cool if engaged for longer than 30 seconds.*

⚠WARNING *Jump starting a battery incorrectly can cause battery to explode, resulting in severe personal injury or death. Do not smoke or allow any ignition source near the battery, and do not jump start a frozen battery.*

6. Turn ignition switch to ON to start engine.

FLYWHEEL ALTERNATOR

This unit is equipped with a permanent magnet flywheel alternator and solid-state voltage regulator-rectifier (Figure 7). As with all solid-state electrical units, precautions are necessary when servicing.

⚠CAUTION *Reversing positive and negative battery connections or allowing engine to run without being connected to the alternator will result in engine electrical system damage. Do not switch battery connections or allow engine to run without being connected to the alternator.*

Weak ignition spark or a discharged battery indicates trouble in the charging system. Before testing the engine's charging system, always check the battery for serviceability.

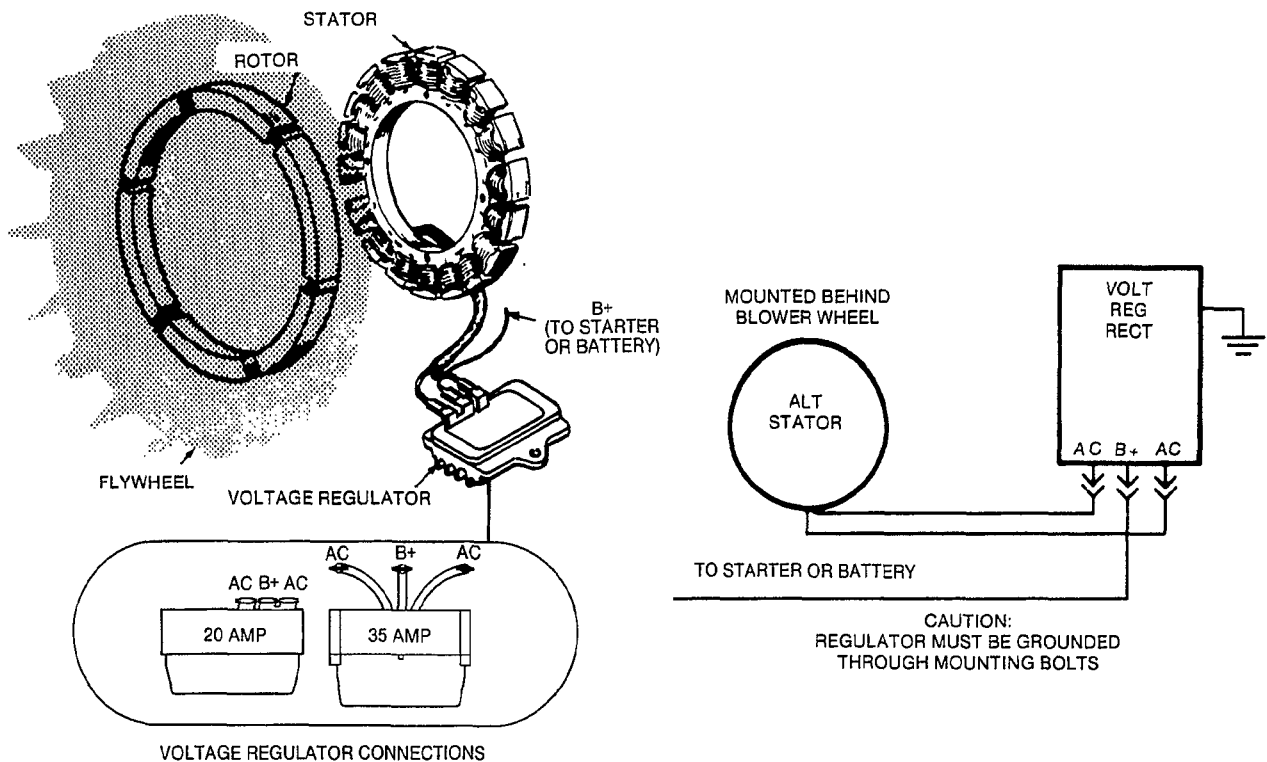

ES-1333-1

ES-1332

FIGURE 7. FLYWHEEL ALTERNATOR SYSTEM

Keep these points in mind when testing or servicing the flywheel alternator:

1. Be sure engine is being run long enough and fast enough to recharge battery after each start. Charging system tests require a full charged battery. Alternator output is reduced in direct proportion to engine rpm. Also, power required for accessories reduces power available to recharge battery.
2. The regulator-rectifier has built in protection against open circuits or short circuits on the alternator output (B+) terminal. Either condition will cause the regulator-rectifier to shut off and appear as if it is not functioning. Prior to checking the regulator-rectifier, check all wiring between the regulator-rectifier B+ terminal and the battery positive (+) terminal to assure it is free of open circuits, resistances or short circuits. Also, if the battery is extremely discharged it may have insufficient power to "turn on" the regulator-rectifier.
3. Be sure regulator-rectifier plug (connector) is inserted properly. Plug must bottom in receptacle; this eliminates any resistance due to a poor connection. Keep clean and tight.
4. Make sure alternator stator leads are not shorted together.
5. Be sure regulator-rectifier has a good ground connection. Mating surface for mounting must be clean and fasteners tightened properly.
6. Never reverse the battery leads.

When the engine is running between 1800 to 2600 rpm, observe the panel ammeter (if not already equipped, connect a test ammeter). If no charging is evident, proceed with the *Alternator Output Test*.

ALTERNATOR OUTPUT TEST

Use a volt-ohmmeter, such as the Simpson 270, when testing the charging system.

1. Check battery voltage with unit not running. If not within specifications (Table 1) charge battery before proceeding to step 2.
2. With the engine running, check the battery terminal voltage (regulator output) using a DC voltmeter. Voltage output should be within the values specified in Table 1. If voltage is greater than specified, replace regulator-rectifier assembly. If voltage is less than specified, proceed to step 3.
3. Examine all wires for loose, corroded, or broken connections. Check fuses. Repair as needed to assure continuity between the regulator-rectifier B+ terminal to battery positive (+) terminal. Also check ground path from battery negative (-) terminal to regulator-rectifier case. Make sure ground connections are clean and secure. If battery voltage remains low with engine running, proceed to step 4.
4. Disconnect both AC stator leads from the regulator-rectifier and test the AC voltage at the stator leads with engine running. If AC voltage reads more or less than specified in Table 1, proceed to step 5. If AC voltage is as specified but DC voltage is low, replace regulator-rectifier.
5. Use the Rx1 scale on the ohmmeter for detecting an open or ground in the stator (unit not running). Disconnect both AC stator leads from the regulator-rectifier. Connect one ohmmeter test lead to a stator lead, connect the other test lead to ground. Reading should show an open (no continuity). If it doesn't, the stator must be replaced. If reading shows no continuity, measure the resistance of the stator winding by connecting one ohmmeter lead to each lead coming from the stator. Refer to Table 1 for resistance specifications. If resistance is not as specified, replace stator. If stator resistance readings are as specified and windings are not shorted or open, low AC voltage may be due to loss of magnetism. If so, blower wheel assembly must be replaced.

TABLE 1. TESTING 20 AND 35 AMPERE SYSTEMS

BASIC TEST	BATTERY	REGULATOR	STATOR AC VOLTAGE	STATOR RESISTANCE
PROCEDURE	Refer to <i>Alternator Output Test</i>	Refer to <i>Alternator Output Test</i>	Refer to <i>Alternator Output Test</i>	Refer to <i>Alternator Output Test</i>
SPEC A 20 AMP	12 to 13 VDC	13.6 to 14.7 VDC	Approximately 21 VAC @ 1800 rpm Approximately 41 VAC @ 3600 rpm	0.06 to 0.10 Ohms
BEGIN SPEC B 20 AMP	12 to 13 VDC	13.6 to 14.7 VDC	Approximately 29 VAC @ 1800 rpm Approximately 57 VAC @ 3600 rpm	0.10 to 0.19 Ohms
35 AMP	12 to 13 VDC	13.6 to 14.7 VDC	Approximately 24 VAC @ 1800 rpm Approximately 47 VAC @ 3600 rpm	0.06 to 0.10 Ohms

TYPICAL WIRING DIAGRAM

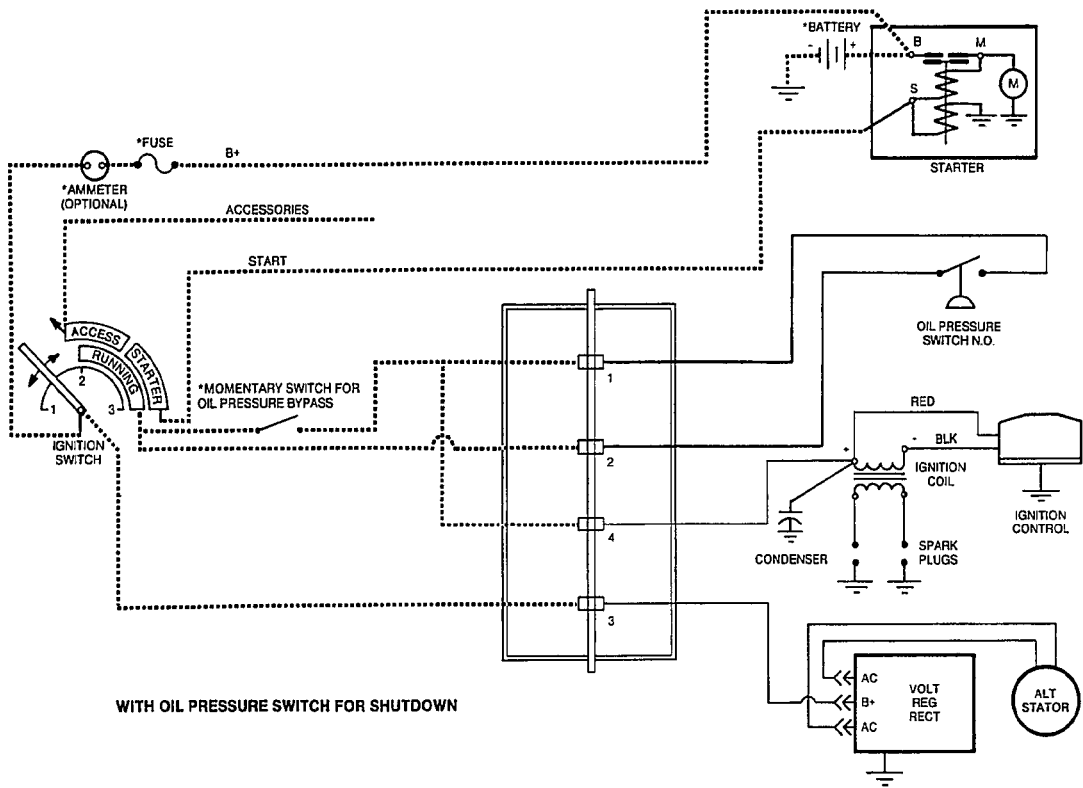
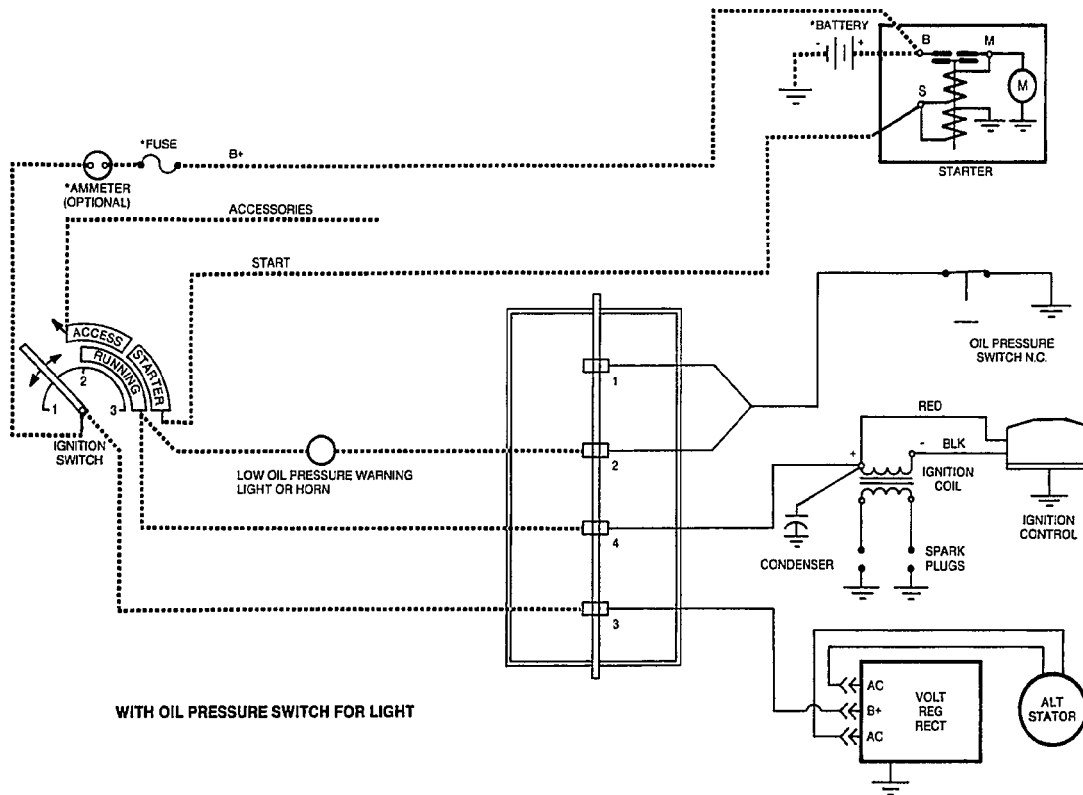

ES-1667

These typical wiring diagrams show the basic wiring necessary for operation of the engine. Your engine may differ in circuitry and features depending on how the equipment manufacturer chose to configure the final product.

Starting System

ELECTRIC STARTER

Normally the starter will require little or no service other than possible brush replacement. However, if through accident or misuse, the starter requires service or overhaul, the following will provide the information necessary to perform this service.

Service

When starting engine, note starter motor action. The pinion gear should mesh quickly with flywheel ring gear and spin engine. Once engine starts and solenoid opens, the starter should disengage and stop. If starter cranks engine slow, or not at all, check start circuit components. Failure to crank is normally caused by low battery charge, defective battery cables, corroded or poor connections, or low temperatures. If after checking these variables, starter continues to crank slowly, starter must be removed and repaired.

Starter Removal

⚠WARNING *Accidental starting of the engine can result in severe personal injury or death. Disconnect the negative battery cable and spark plug wires while servicing engine, controls, or associated equipment.*

1. Remove both battery cables from battery. Disconnect ground cable first.
2. Disconnect battery cable and electrical lead wires from starter.
3. Remove starter motor.

Starter Disassembly

1. Remove "M" terminal nut and wire lead from solenoid (Figure 1).
2. Remove the two solenoid mounting screws and remove solenoid.
3. Scribe a mark across frame and rear bracket to aid in assembly. Remove the two through bolts.
4. Remove rear bracket and frame assembly.
5. Carefully remove armature and lever from front bracket. Note direction of lever and retainer.
6. Remove the two brush mounting screws, and remove the rear bracket.
7. Remove brush holder assembly from the frame by pulling the brushes out.

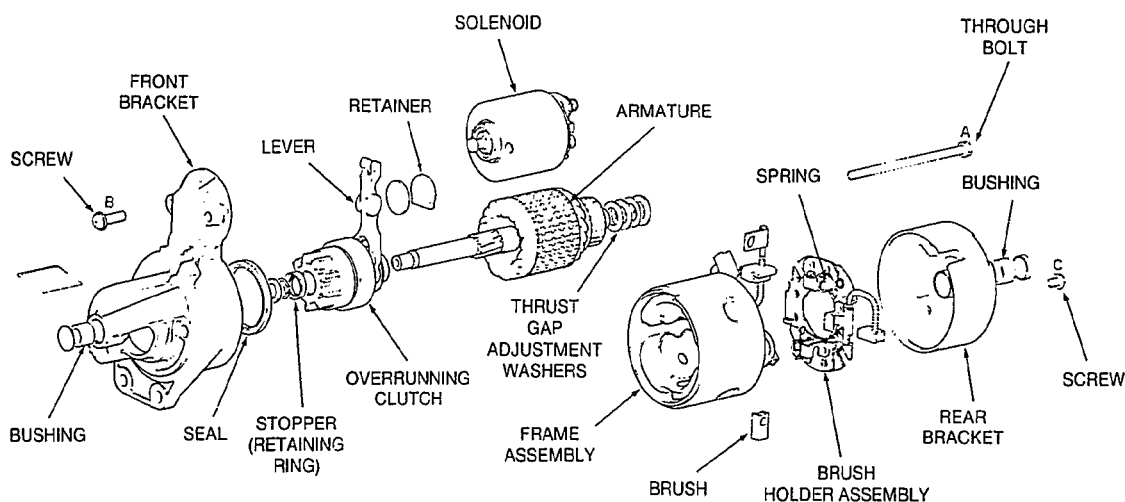

FIGURE 1. STARTER MOTOR

ES-1665

8. Push stopper toward pinion and remove snap ring (Figure 2).

9. Remove stopper and overrunning clutch from armature shaft.

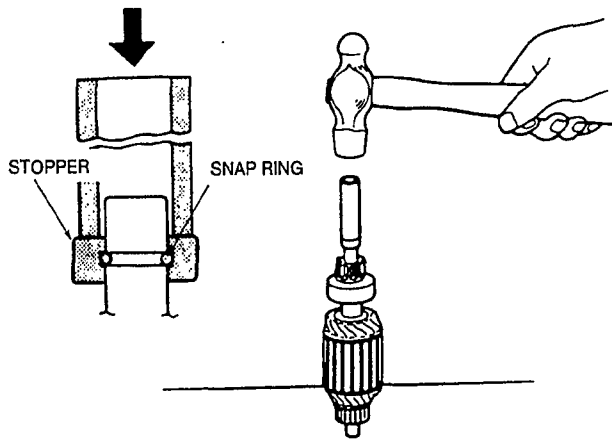

FIGURE 2. REMOVING OVERRUNNING CLUTCH

ES-1622

10. Inspect starter for damaged or worn parts.

11. Repair or replace all damaged or worn parts as needed.

Starter Assembly

1. Install seal in nose housing. Install overrunning clutch on the armature shaft.

2. Slide stopper on the armature shaft. Position snap ring in groove in armature shaft.

3. Pull stopper all the way over snap ring (Figure 3). It may be necessary to tap snap ring into groove with a punch while maintaining tension on stopper.

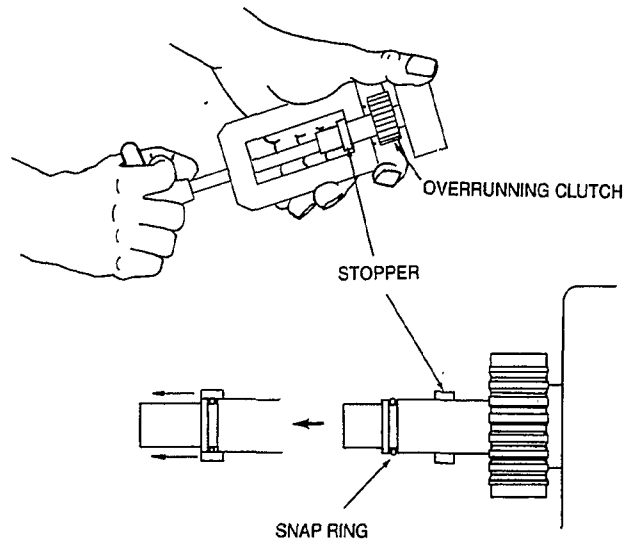

ES-1194

FIGURE 3. INSTALLING STOPPER

4. Lubrication: When starter motor is assembled apply grease to each of the following points (Recommended grade: Multemp PS No. 2):

- Armature shaft spline
- Both bushings (Both ends of armature)
- Stopper on armature shaft
- Pinion gear
- Sliding portion of lever

5. Fit overrunning clutch into lever, and install with armature in the front bracket.

6. Install lever retainer and spacer. Position frame assembly over armature on the front bracket.

7. Install brush holder assembly. Position brushes in brush holder. Make certain positive lead wires are not grounded.

8. Install washers, as required, on the rear end of armature shaft to obtain an armature shaft thrust gap of 0.002 to 0.02 inch (0.05 to 0.5 mm). New washers are required if rear bracket is replaced.

Table 1. Starter Assembly Torques

Solenoid Screws	54 in.-lb.	(6.1 Nm)
Brush Retaining Screws	33 in.-lb.	(3.7 Nm)
Through Bolts	51 in.-lb.	(5.8 Nm)

9. Install rear bracket. Secure brush holder to rear bracket with two machine screws.

10. Install and tighten the two through capscrews.
11. Install solenoid plunger in lever. Secure solenoid to front bracket with two machine screws.
12. Install wire lead to the terminal "M" on solenoid.
13. After assembly, adjust pinion clearance. Pinion clearance should be 0.02 to 0.08 inch (0.5 to 2.0 mm); if not, check as follows (Figure 4):
 - A. Connect starter to a battery. Close switch. This will shift pinion into cranking position.
 - B. Push pinion back by hand and measure pinion clearance. If clearance does not fall within the specified limits, adjust by adding or removing shims located between solenoid and front bracket. Adding shims decreases clearance; removing shims increases clearance. Shims are included with replacement solenoid.

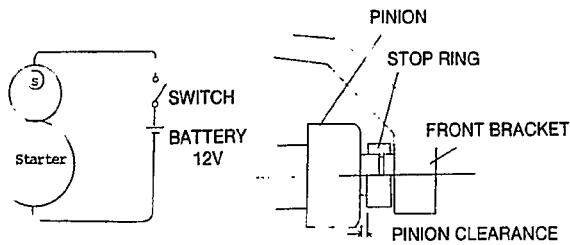

ES-1623

FIGURE 4. PINION CLEARANCE ADJUSTMENT

Inspection and Testing

Inspect the starter components for mechanical defects before testing for grounds or shorts.

Testing Armature for Grounds: Touch armature shaft or core and the end of each commutator bar with a pair of ohmmeter leads (Figure 5). A low ohmmeter reading indicates a grounded armature. Replace grounded armature.

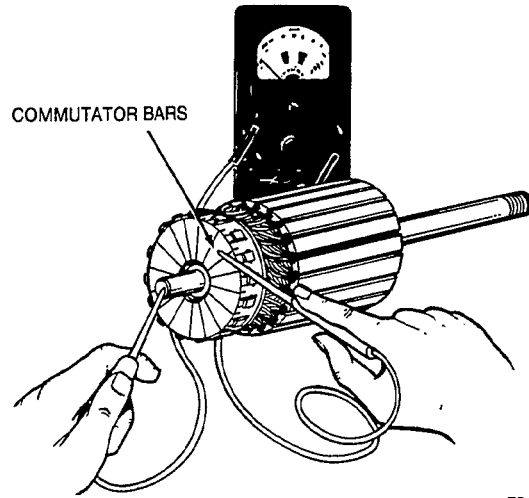

ES-1001

FIGURE 5. TESTING ARMATURE FOR GROUNDS

Testing Armature for an Open Circuit: Using an ohmmeter, check for continuity between the commutator segments. If there is no continuity (high resistance), the segments are open and armature must be replaced.

Testing Armature for a Short Circuit: Use a growler for locating shorts in the armature (Figure 6). Place armature in growler and hold a thin steel blade (e.g. hacksaw blade) parallel to the core and just above it while slowly rotating armature in growler. A shorted armature will cause the blade to vibrate and be attracted to the core. If armature is shorted, replace with a new one.

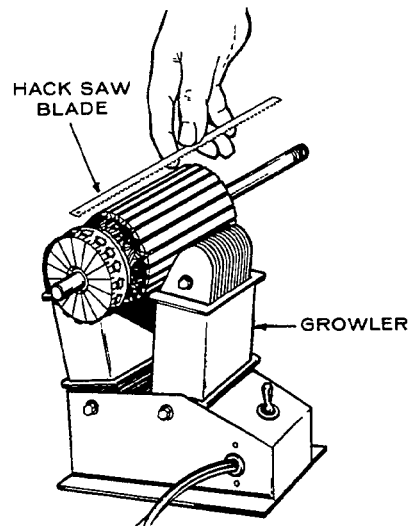

ES-1002

FIGURE 6. TESTING ARMATURE FOR SHORT CIRCUITS

Commutator Inspection: If commutator is dirty or discolored, clean with number 00 to 000 commutator paper. Blow grit out of armature after cleaning.

If commutator is scored, rough, or worn, turn it down in a lathe.

Field Coil: Use an ohmmeter to check for continuity between brushes. If there is no continuity, the field coil is open and must be replaced. With field coil mounted in the frame, check for continuity between the field coil and frame. Replace frame assembly if there is continuity.

Brushes: Clean around brushes and holders, wiping off all brush dust and dirt. If brushes are worn shorter than .4528 inch (11.5 mm) replace them (Figure 7).

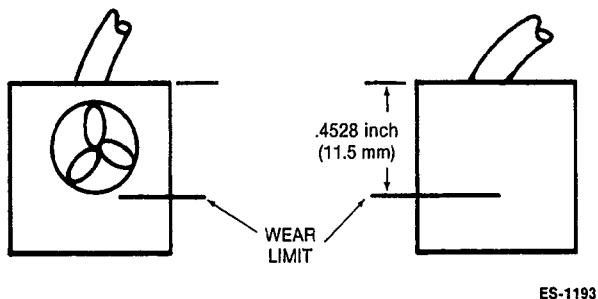

FIGURE 7. BRUSH WEAR LIMIT

Check for shorts between positive side of brush holder and brush holder base. If there is continuity, replace holder assembly. Check for free movement of brushes. All brushes should move freely in the brush holders.

Overrunning Clutch: Inspect pinion and spline teeth for wear or damage.

If pinion gear is worn or damaged, inspect flywheel ring gear also. Rotate pinion. It should turn free when turned in one direction, and lock when turned in the opposite direction.

CAUTION *Cleaning overrunning clutch in liquid cleaning solution will result in starter damage. Do not clean overrunning clutch in liquid cleaning solutions.*

Solenoid: Push solenoid plunger in and release it. The plunger should return to its original position. While holding plunger all the way in, check for continuity between terminals "M" and "B". If there is no continuity, replace the solenoid (Figure 8). After replacing solenoid check pinion clearance.

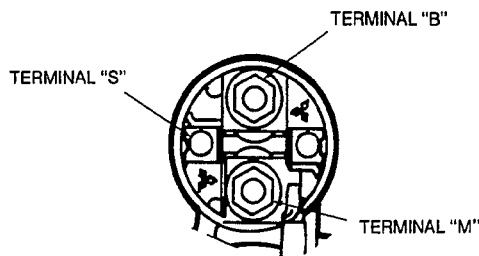

FIGURE 8. SOLENOID TERMINALS

Bushings: If either the front or rear bushing show signs of wear or damage, replace them. Bushing and rear bracket are replaced as an assembly. Check armature shaft thrust gap if rear bracket is replaced.

Remove front bushing by tapping bushing from inside with a 7/16 inch tap. Do not remove cap from front bracket. Thread capscrew, same size as tap, into bushing. Using a slide hammer remove bushing from front bracket. Press new bushing into front bracket. Use care not to distort inside diameter of bushing.

Brush Replacement: Cut old positive brush from pigtail at the brush. Be careful not to damage field coil. Clean 1/4 to 3/8 inch (6.5 to 9.5 mm) of brush end of pigtail with sandpaper or emery cloth. (Figure 9).

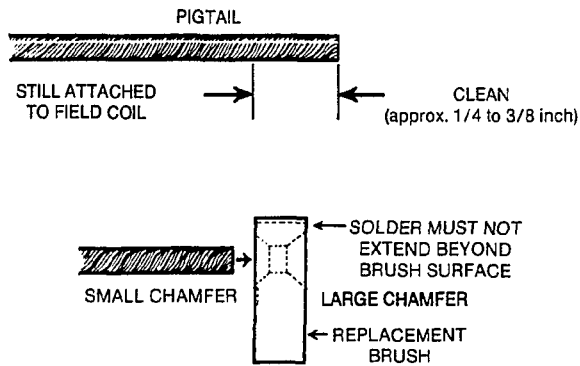

FIGURE 9. BRUSH REPLACEMENT

Push prepared end of pigtail lead into hole in replacement brush from the small chamfered side. Solder pigtail lead to replacement brush on the large chamfered side, using 50/50 tin/lead, rosin core solder and a standard 240/325 Watt soldering iron. Use a file to remove any excess solder that may extend beyond brush surface.

CAUTION *Material protruding from soldered side surface of brush can cause equipment damage. Do not use excessive solder or heat and file any excess material from brush surface.*

Starter Mounting

Before installing starter motor, make sure the starter mounting surface on the engine base is clean and free of oil.

To install starter use the following procedure. The starter pinion gear lash does not require adjustment.

1. Install starter motor and torque mounting capscrews to that specified in *ASSEMBLY TORQUES*.
2. Connect battery cable and wires to starter. Connect battery cables to battery. Connect ground cable last.

Engine Disassembly

DISASSEMBLY/ASSEMBLY

When complete engine disassembly is necessary, first remove all complete assemblies. Individual assemblies such as fuel pump and carburetor can be disassembled and repaired at another time.

Suggested Disassembly Order

1. Drain crankcase.
2. Disconnect all exhaust and electrical lines.
3. Remove engine from its mountings and place on a suitable bench or work stand.
4. Remove all housings, shrouds, blower housings, etc.
5. Remove flywheel, using a puller.
6. Remove ignition trigger and gear cover, being careful to protect oil seal from keyway damage.
7. Remove crank gear, using a gear puller and ring.
8. Remove all accessories such as oil filter, starter, intake manifold, fuel lines, spark plugs, etc.
9. Remove oil base, oil pump and cylinder heads.
10. Remove valves, springs, lifters, etc.
11. Remove camshaft and gear assembly.
12. Remove connecting rods and pistons.
13. Remove rear bearing plate, crankshaft, and front bearing.

Keep all parts in their respective orders. Keep valve assemblies together. Return rod caps to their respective pistons. Analyze the reasons for parts failure.

Suggested Assembly Procedure

Engine assembly is normally the reverse of the disassembly procedure, observing proper clearances and torques. Use a torque wrench to assure proper tightness. Coat the internal engine parts with oil as they are assembled. After the internal engine parts are assembled, the engine should turn over by hand freely. Use only genuine Onan parts and special tools when reassembling your engine.

1. Use proper bearing driver to install front main bearing after coating it with a light film of oil.
2. Insert rear main bearing in rear bearing plate.
3. Insert crankshaft, rear bearing plate, and crankshaft gear.
4. Install pistons and connecting rods.
5. Install camshaft and gear assembly; align crank gear mark with cam gear mark.
6. Install valve assemblies, oil pump, oil base, and cylinder heads.
7. Install all accessories such as oil filter, starter, fuel lines and spark plugs.
8. Install gear cover with oil seal, trigger ring, and flywheel.
9. Check valve clearance.
10. Install all housings and air cleaner.
11. Fill crankcase with oil.

Operation

Start engine and check oil pressure. Run for approximately 15 minutes to bring engine to operating temperatures. Check for oil leaks, fuel leaks, and exhaust leaks. Adjust carburetor and governor for speed and sensitivity.

Testing Compression

The compression tester is used to determine the condition of valves, pistons, piston rings and cylinders.

To check compression:

1. Run the engine until thoroughly warm.
2. Stop engine and remove spark plugs.
3. Remove air cleaner and place throttle and choke in the wide open position.
4. **Insert the compression gauge** in one spark plug hole.
5. Crank the engine and note the reading.

Refer to *SPECIFICATIONS* for compression pressures. There may be variations due to equipment, temperature, atmospheric conditions and altitude. These pressures are for a warm engine at cranking speed (about 300 rpm).

Tappet Adjustment

The engine is equipped with adjustable valve tappets. The valve tappet clearance should be checked and adjusted as specified in the *Periodic Maintenance Schedule* (located in the Operator's Manual). Adjust the valve clearance only when engine is at ambient temperature. Proceed as follows:

1. Remove ignition key to prevent accidental starting.
2. Remove all parts necessary to gain access to valve tappets.
3. Remove spark plugs to ease the task of turning the engine over by hand.
4. Place a socket wrench on the flywheel capscrew and rotate the crankshaft in a clockwise direction until the left intake valve (viewed from flywheel end) opens and closes. Continue turning the crankshaft until the TC mark on the flywheel is lined up with the TC mark on the gear cover. This should place the left piston (#1) at the top of its compression stroke. Verify that the left intake and exhaust valves are closed and there is no pressure on the valve lifters.
5. The correct feeler gauge for the valve adjustment (see *SPECIFICATIONS*) should pass freely between valve cap (P216, P218, P220) or valve stem (P224) and tappet; a 0.002 inch (0.05 mm) thicker gauge should not (Figure 1).
6. To correct valve clearance, use a 7/16 inch open end wrench to turn the adjusting screw to obtain the correct clearance. The screw is self-locking and will stay where it is set. A 9/16 inch (14 mm) open end wrench is required to hold the tappet while turning the adjusting screw.
7. To adjust valves on the right hand cylinder, turn engine one complete revolution and again line up mark on the flywheel and the TC mark on the gear cover. Then follow adjustment procedure given for left hand cylinder.
8. Replace all parts removed in Step 2. Tighten all screws securely. Torque manifold bolts to specified torque.

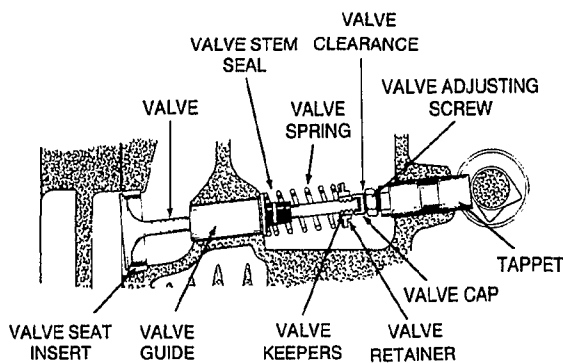

VT-1034

FIGURE 1A. INTAKE VALVE ASSEMBLY - P216, P218, P220

VALVE SYSTEM

A properly functioning valve system is essential for good engine performance. All engines utilize an L-head type valve design as shown in Figure 1. Access to the valve system can be obtained by removing the cylinder heads and the valve covers on top of the engine. A valve spring compressor must be used to remove valves from the cylinder block.

A valve stem seal is used on the intake valve guides. This seal must be replaced each time the valve is removed.

Place valves, springs, retainers, and tappets in a rack as they are removed from cylinder block so they can be identified and reinstalled in their original locations. Discard old valve stem seals and replace with new ones during assembly.

Use the following procedures to inspect and service the valve system.

Inspection

Clean carbon from the valves, valve seats, valve guides, and cylinder block.

Valves: Check the valve face for evidence of burning, warpage, out-of-round, and carbon deposits.

Burning and pitting are caused by the valve failing to seat tightly. This condition is often caused by hard carbon particles on the seat. It may also be due to weak valve springs, insufficient tappet clearance, warpage, and misalignment.

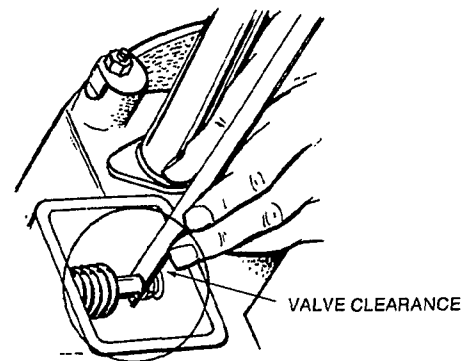

VT-1000

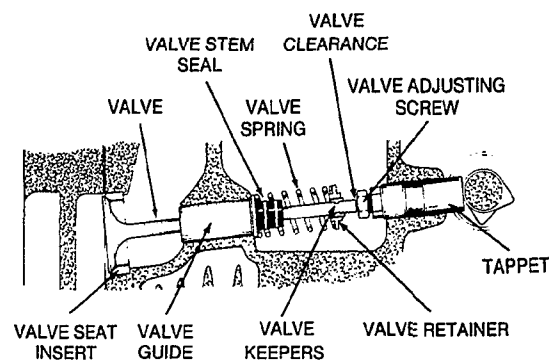

VT-1035

FIGURE 1B. INTAKE VALVE ASSEMBLY - P224

Warping occurs chiefly in the upper stem due to its exposure to intense heat. Out-of-round wear follows when the seat is pounded by a valve whose head is not in line with the stem and guide. If a valve face is burned or warped, or if the stem is worn, install a new valve.

Too much clearance in the intake guide admits air and oil into the combustion chamber, upsetting carburetion, increasing oil consumption, and making heavy carbon deposits. Carbon reduces heat dissipation. Clean metal is a good heat conductor but carbon insulates and retains heat. This increases combustion chamber temperatures which causes warping and burning.

Unburned carbon residue gums valve stems and causes them to stick in the guide. Deposits of hard carbon with sharp points projecting become white hot and cause pre-ignition and pinging.

Refinish valves that are slightly pitted or burned on an accurate valve grinder. If valves are badly pitted or have a thin margin when refacing, replace them.

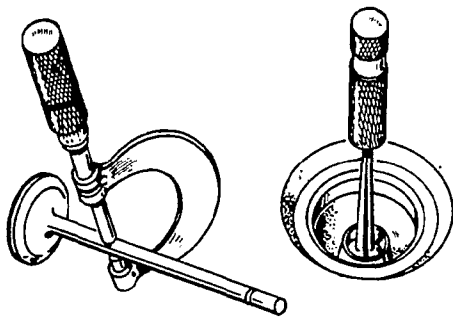

VT-1020

FIGURE 2. VALVE STEM AND VALVE GUIDE INSPECTION

Stems and Guides: Always check valve stems and guides for wear (Figure 2). Use a hole gauge to measure the valve guide. When clearance with stem exceeds that specified in *DIMENSIONS AND CLEARANCES* replace either valve or guide or both, as may be necessary. Always regrind seat to make concentric with the newly installed guide.

Worn valve stem guides can be replaced from inside the valve chamber (a seal is provided behind the intake valve guides only). The smaller diameter of the tapered valve guides must face toward the valve head. Tappets are also replaceable from the valve chamber after first removing the valve assemblies.

Valve Guide Removal: Before removing valve guides, use an electric drill with a wire brush to remove carbon and other foreign material from top surface of guides. Failure to perform this operation may result in damage to the guide bores. Drive the guides out with a hammer and valve guide drive.

CAUTION Driving out old valve guides can cause guide and tappet bore damage. Do not strike guide or tappet bores with driver during removal.

Valve Guide Installation: Run a small polishing rod covered with crocus cloth through valve guide holes to clean out carbon and other foreign materials. Place a new gasket on the intake valve guide, and coat the outer edge of each new guide with oil. Place guide in cylinder block and press in until guide protrudes 11/32 inch (8.7 mm) from valve box side of block. A suggested method of installation is shown in Figure 3.

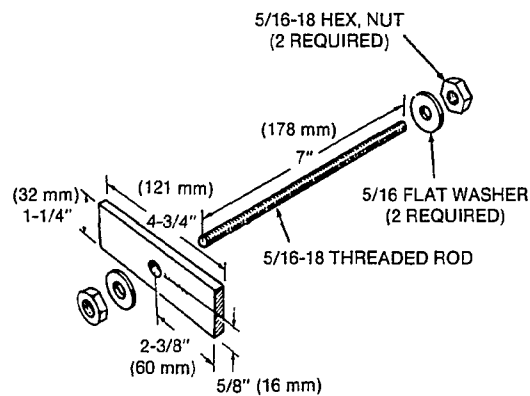
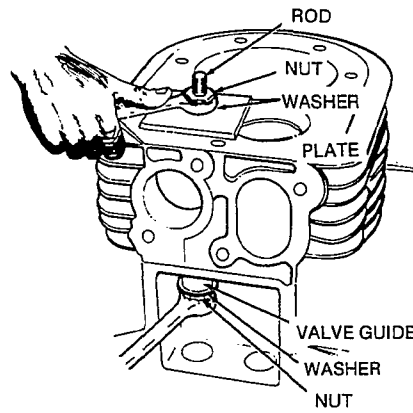

VT-1023

FIGURE 3. VALVE GUIDE INSTALLATION

Valve Stem Seals (intake only): Do not reuse valve stem seals. Each time the valves are removed from cylinder block, a new seal must be used when valve is reinstalled.

CAUTION Removing a valve after installing valve stem seal can cause seal damage. Do not allow valve stem groove to come in contact with valve stem seal after installation.

Valve Spring: Check valve springs for cracks, worn ends, distortion, and tension. If spring ends are worn, check valve spring retainer for wear. Check for spring distortion by placing spring on a flat surface next to a square. Measure height of spring and rotate it against square edge to measure distortion. If distortion exceeds 0.06 inch (1.5 mm) replace spring. Check spring tension at the installed height for both the valve open and closed position using an accurate valve spring tester. Replace any valve spring that is weak, cracked, worn, or distorted.

Valve Rotators: The P216, P218, and P220 engines use free-rotating intake and exhaust valves. While in the open position, the valves must rotate freely.

The P224 engine uses positive type valve rotators on the exhaust valves. When functioning properly, the valves are rotated a fraction of a turn each time they open. While in the open position, the valves must rotate freely. There is no easy way to determine if a valve rotator is good or bad. Onan recommends that valve rotators be replaced at each major overhaul or if a build up of carbon is noted on valve face and valve seat.

Valve Seats: Inspect valve seat inserts. If seats are loose, cracked or severely pitted, new ones must be installed. Remove valve seat inserts using a valve seat removal tool. If valve seat insert bores in cylinder block are damaged or worn so that a press fit cannot be obtained when installing new standard size valve seat inserts, the bores must be machined for an oversize seat.

USE NEW VALVE SEAT TO ADJUST PULLER DEPTH

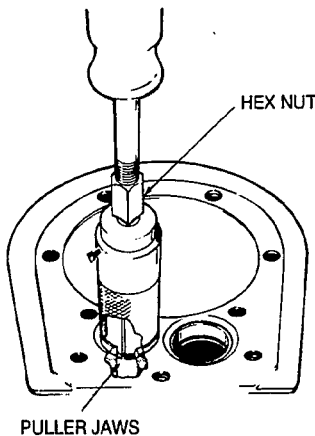
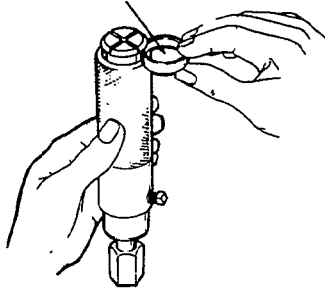
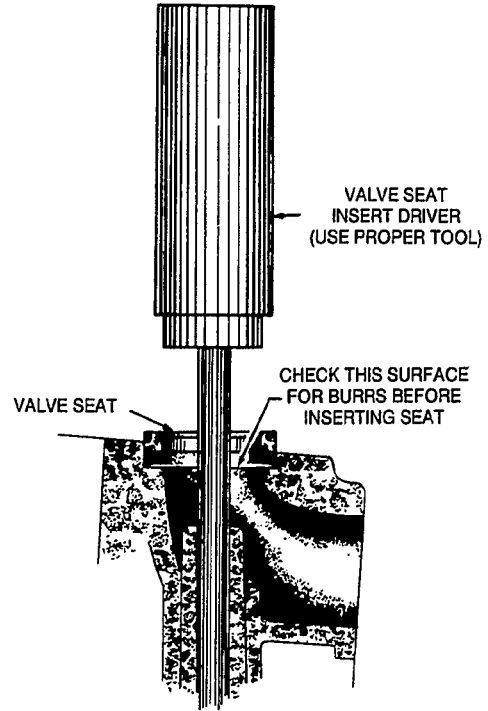

FIGURE 4. VALVE SEAT REMOVAL

C-1104

Valve Seat Removal: Remove carbon and combustion deposits from valve seat. Select proper puller size determined by inside diameter of valve seat. On some pullers use a new seat as a guide to adjust puller depth (Figure 4). Puller jaws must expand into cylinder block at the point where bottom of valve seat insert rests on cylinder block. Position puller on valve seat and tighten hex nut. Clamp cylinder block to a solid bench. Attach slide hammer to puller. Tighten hex nut between each blow with the slide hammer.



VT-1025

FIGURE 5. INSERTING NEW VALVE SEAT

Valve Seat Installation: After the old seat has been removed, clean out any carbon or metal burrs from the seat insert recess. Use a valve seat insert driver and hammer to install the insert (Figure 5). Drive the valve seat insert in so the insert enters the recess evenly. Make certain that the valve seat insert rests solidly on the bottom of the recess all the way around its circumference.

To assure a tight valve seat fit and eliminate the danger of seat loosening in the bore, valve seat must be staked.

Insert valve seat staker into valve seat or guide in cylinder block. Using a lead hammer, strike the staking tool a sharp blow to wedge new valve seat securely in place. It will be necessary to refinish valve seat inserts before installing valves.

TAPPETS

Very little wear takes place on tappet diameters or in tappet bores. If the clearance between tappet and bore in cylinder block exceeds specifications, replace the tappet.

Inspect the tappet faces which contact camshaft lobes for roughness, scuffing, or concave wear. Replace any worn tappets. If tappets are worn, inspect camshaft for wear.

VALVE FACE AND SEAT GRINDING

Before installing new valves or previously used valves, inspect valve seats for proper valve seating. If used valves are reinstalled, the valve stems should be cleaned and valve faces ground to their specified angles of 44° . Refinish valve seats to a 45° angle. When refacing valves and seats, remove all evidence of pitting and grooving. If end of valve stem is pitted or worn, true it and clean it up on the refacer wheel. A very light grind is usually enough to square stem and remove any pits or burrs. The valve guide should be thoroughly cleaned. If valve guide is worn, or valve is warped, the necessary parts must be replaced.

By grinding the valve face and seat at slightly different angles, a fine line of contact on face and seat is obtained, eliminating the need to lap the seating surfaces. The one degree difference in angles is defined as the interference angle (Figure 6). The seat angle is greater than that of the valve face. This assures contact at the maximum diameter on valve seat seating surface.

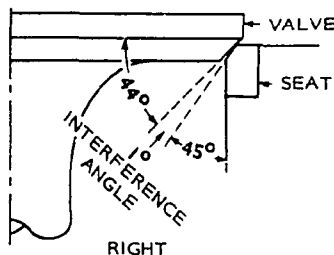

FIGURE 6. VALVE INTERFERENCE ANGLE

VT-1021

Refinish valve faces to a 44° angle on a valve refacing machine. The first cut from valve face must be a light grinding. Check if there is an unevenness of metal being removed. If only part of valve's face has been touched, check to see if valve is properly seated in machine or if valve is warped, worn, or distorted. When cut is even around the whole valve face, keep grinding until complete face is ground clean. Be sure the correct valve face angle is maintained. When valve head is warped, a knife edge will be ground (Figure 7) on part or all of the head due to the large amount of metal that must be removed to completely reface valve. Heavy valve heads are required for strength and good heat dissipation. Knife edges lead to breakage, burning, and pre-ignition due to heat localizing on the edge.

Replace any valve that cannot be entirely refaced while keeping a good valve margin (Figure 7) or is warped, worn, or damaged in any way. The amount of grinding necessary to true a valve indicate whether valve head is worn or warped.

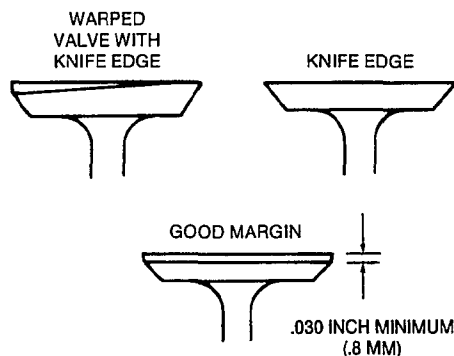

FIGURE 7. VALVE HEAD MARGIN

When new valve seats are installed, or previously used seats reground, refinishing must be done with a valve seat grinder used according to the manufacturer's directions.

Valve seats should be ground with a 45 degree stone and the width of the seat band should be $1/32$ inch to $3/64$ inch (0.8 to 1.2 mm) wide. Grind only enough to assure proper seating.

Place each valve in its proper location. Check each valve for a tight seat. Make several marks at regular intervals across the valve face using machinist's bluing. Observe if the marks rub off uniformly when the valve is rotated part of a turn against the seat. The valve seat should contact the valve face evenly at all points. The line of contact should be at the center of the valve face.

FLYWHEEL

Removing the flywheel is a relatively simple process, but the following procedure must be followed to avoid damage to the gear case and possible injury to the operator.

⚠ WARNING *Incorrect flywheel removal can result in severe personal injury. Do not remove flywheel screw completely when using flywheel puller.*

1. Turn the flywheel mounting screw outward about two turns.
2. Install a puller bar on the flywheel (Figure 8).

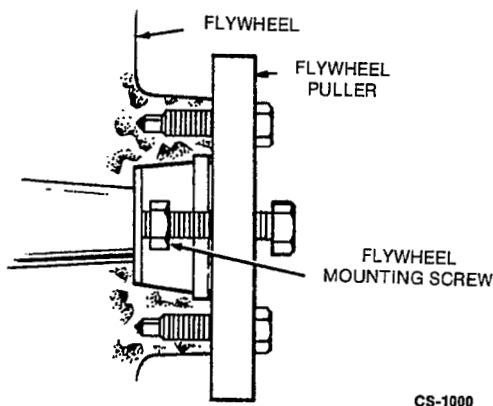

FIGURE 8. BLOWER WHEEL PULLEY

3. Turn the puller bar bolts in, alternately, until the wheel snaps loose on the shaft.

⚠ CAUTION *Improper flywheel removal can cause gear case damage. Do not use any tools to pry against gear cover when removing flywheel.*

4. Unscrew the puller from the flywheel, remove the flywheel mounting screw and washer and pull the flywheel off the shaft. Take care not to drop the wheel. A bent or broken fin will destroy the balance.

GEAR COVER

After removing the mounting screws, tap the gear cover gently with a soft faced hammer to loosen it.

When installing the gear cover, make sure the pin in the gear cover engages the nylon lined (smooth) hole in the governor cup. Turn the governor cup so the nylon lined hole is at the three o'clock position. Use a small amount of grease to assist in holding governor cup in position. The smooth side of the governor yoke must ride against the governor cup. Turn the governor arm and shaft clockwise as far as possible and hold in this position until the gear cover is installed flush against the crankcase. Be careful not to damage the gear cover oil seal (Figure 9).

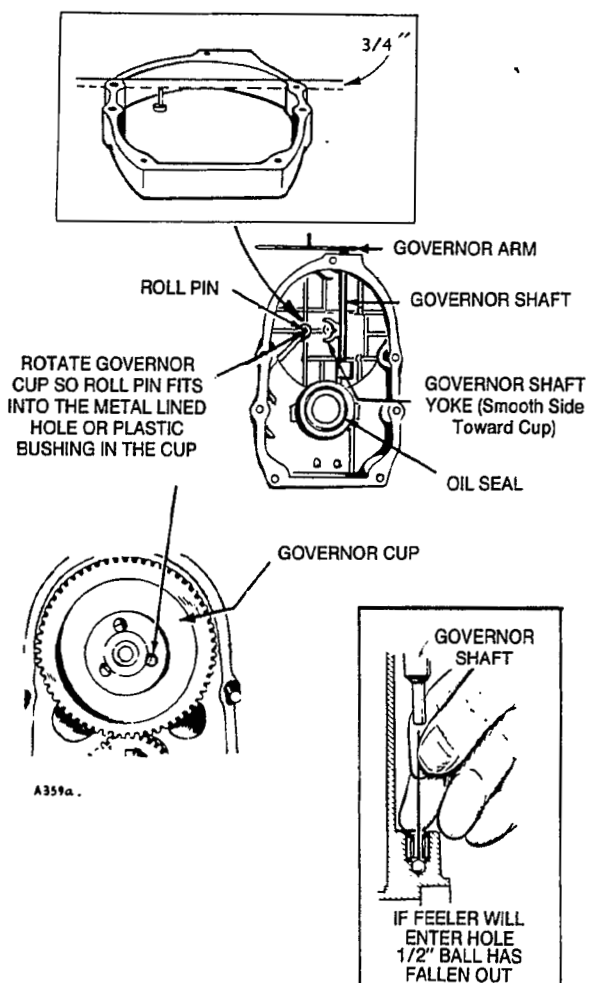
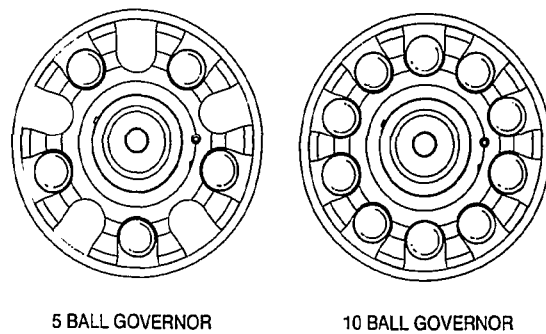
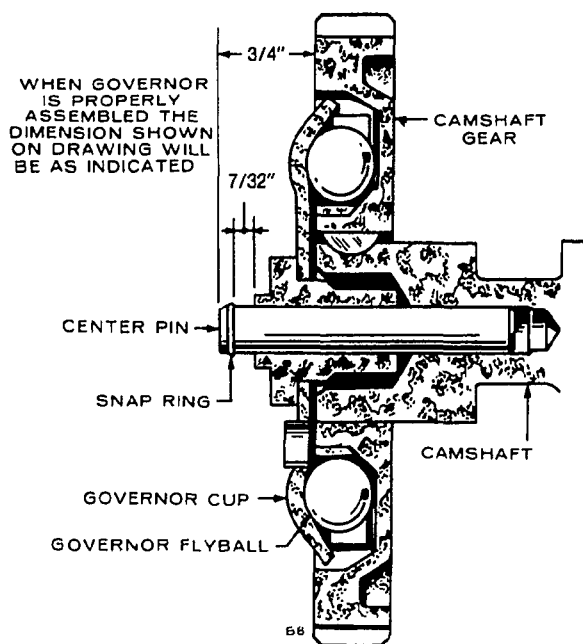

FIGURE 9. GEAR COVER ASSEMBLY



FLYBALL LOCATIONS

CS-1238

FIGURE 10. GOVERNOR CUP DETAILS

GOVERNOR CUP

With the gear cover removed, the governor cup can be taken off after removing the snap ring from the camshaft center pin. Catch the flyballs while sliding the cup off (Figure 10).

Replace with a new part any flyball which is grooved or has a flat spot; the ball spacer if its arms are worn or otherwise damaged; the gear/spacer assembly if loose on gear hub, and the governor cup if the race surface is grooved or rough. The governor cup must be a free-spinning fit on the camshaft center pin, but without any excessive play.

When installing the governor cup, tilt the engine so the gear is up, put the flyballs in place (Figure 10), and install the cup and snap ring on the center pin.

The camshaft center pin extends out 3/4 inch (19 mm) from the end of the camshaft. This distance provides an in-and-out travel distance of 7/32 inch (5.6 mm) for the governor cup, as illustrated. Hold the cup against the flyballs when measuring. The camshaft center pin cannot be pulled outward or removed without damage. If the center pin extends out too far, the cup will not hold the flyballs properly. If the distance is less than 7/32" (5.6 mm), the engine will race, especially at no load. Remove the center pin and press in a new pin.

TIMING GEARS

If replacement of either the crankshaft gear or the camshaft gear becomes necessary, always install both gears new.

The camshaft and gear must be replaced as an assembly. Before removing the camshaft and gear assembly, remove the cylinder head and valve assemblies.

To remove the crankshaft gear, first remove the snap ring and retainer washer, then attach the gear pulling ring using two No. 10-32 screws (Figure 11). Tighten the screws alternately until both are tight. Attach a gear puller to the puller ring and proceed to remove the gear.

Each timing gear is stamped with "O" near the edge. The gear teeth must mesh so that these marks exactly coincide when the gears are installed in the engine. When installing the camshaft gear and shaft assembly, be sure the thrust washer is properly in place behind the camshaft gear. Then install the crankshaft retaining washer and lock ring.

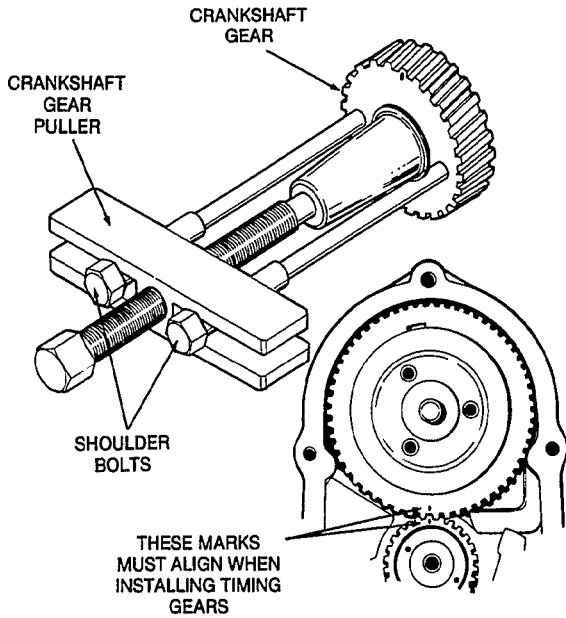

VT-1029-01

FIGURE 11. TIMING GEAR REMOVAL AND INSTALLATION

PISTONS AND CONNECTING RODS

Observe the following procedure when removing pistons and connecting rods from the engine.

1. Drain oil.
2. Remove the cylinder head and oil base pan from the engine.
3. Remove the ridge from the top of each cylinder with a ridge reamer before attempting piston removal (Figure 12).

CAUTION *Improper piston removal can cause piston damage. Use ridge reamer to remove cylinder ridge before removing piston.*

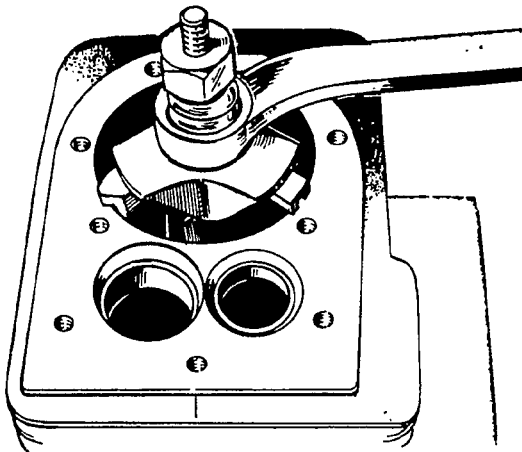

FIGURE 12. REMOVING RIDGE FROM CYLINDER

4. Turn the crankshaft until the piston is at the bottom of its stroke and remove the connecting rod nuts. Lift the rod bearing cap from the rod and push the rod and piston assembly out through the top of the cylinder using a hammer handle. Do not scratch the crankpin and cylinder wall when removing the piston and rod.
5. Mark each piston and rod assembly so they can be returned to their respective cylinders after overhaul. Keep connecting rod bearing caps with their respective rods.
6. Remove the piston rings from the piston with a piston ring spreader (Figure 13). Remove the piston pin retainer and push the piston pin out.

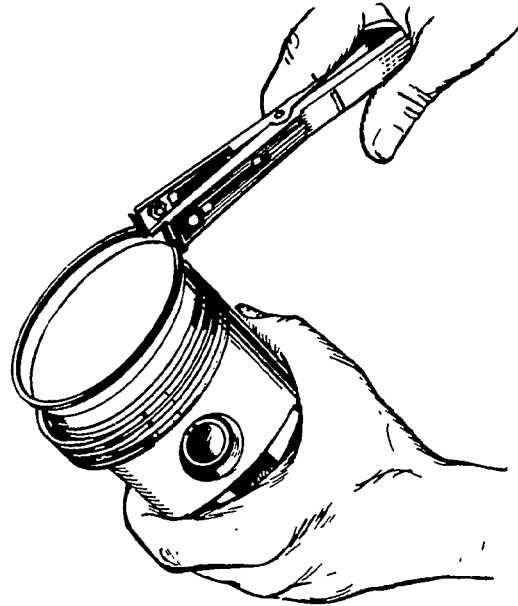

FIGURE 13. REMOVING PISTON RINGS

7. Remove dirt and deposits from the piston surfaces with an approved cleaning solvent. Clean the piston ring grooves with a groove cleaner or the end of a piston ring filed to a sharp point (Figure 14). Care must be taken not to remove metal from the groove sides.

CAUTION *Improper piston cleaning can cause piston damage. Do not use a caustic cleaning solvent or wire brush for cleaning pistons.*

8. Clean the connecting rods in solvent. Blow out all passages with compressed air.

P224

Engines that have been filled with 0.005 inch (0.13 mm) oversize pistons at the factory are identified by the letter E after the serial number. Number is stamped on the cylinder block and on the unit nameplate.

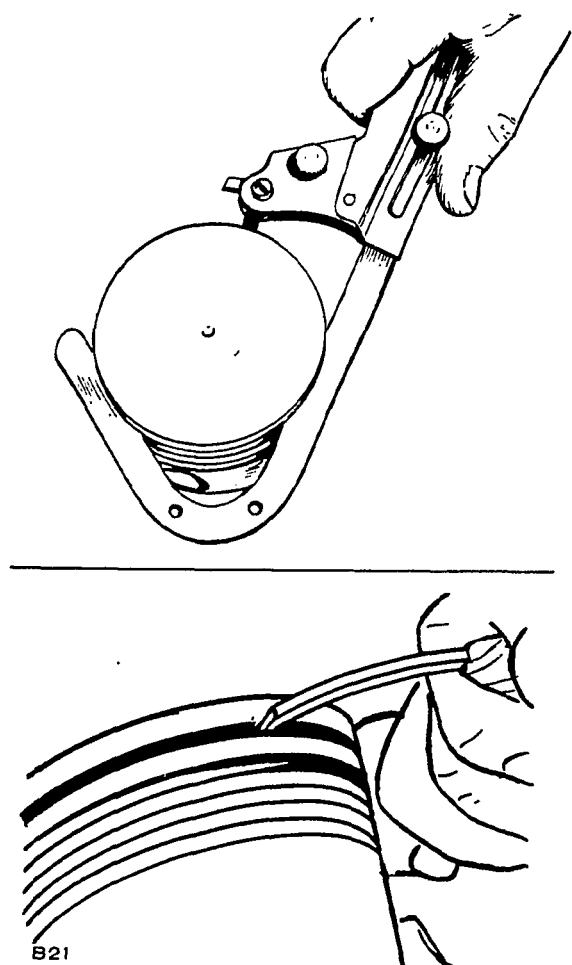

FIGURE 14. PISTON GROOVE CLEANING

Inspection

Follow the procedures given below when inspecting pistons and connecting rods.

Piston Inspection:

1. Inspect the pistons for fractures at the ring lands, skirts and pin bosses. Check for wear at the ring lands using a new ring and feeler gauge (Figure 15). Replace the piston when the side clearance of the top compression ring reaches that specified in *DIMENSIONS AND CLEARANCES*.
2. Replace pistons showing signs of scuffing, scoring, worn ring lands, fractures or damage from preignition. Excessive piston wear near the edge of the top ring land indicates preignition.

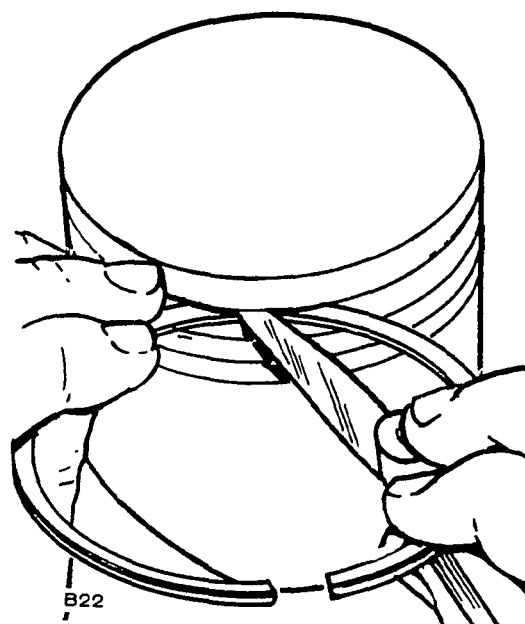

FIGURE 15. CHECKING RING SIDE CLEARANCE

Connecting Rod Inspection:

Replace connecting rod bolts and nuts that have damaged threads. Replace connecting rods that have deep nicks, signs of fractures, scored bores, or bores with dimensions which exceed that specified in *DIMENSIONS AND CLEARANCES*.

Measuring Pistons:

1. Proper piston tolerances must be maintained for satisfactory operation.
2. Refer to *DIMENSIONS AND CLEARANCES* to determine where to measure piston to be sure the total clearance follows specifications.

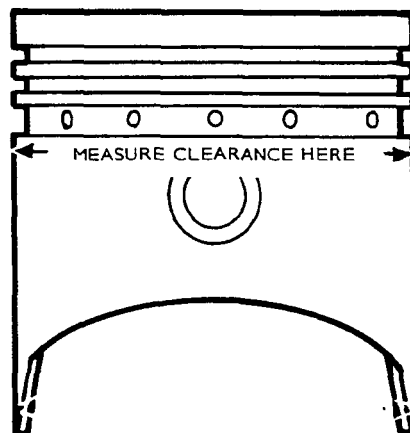

FIGURE 16. MEASURING PISTON CLEARANCE

Measuring Piston Rings:

1. Install the piston ring in the cylinder bore. Invert the piston and push the ring to the end of ring travel, about halfway into the bore, which trues the ring end gap. Check the gap with a feeler gauge (Figure 17).
2. The practice of filing ring ends to increase the end gap is not recommended. If the ring end gap does not meet specifications, check for the correct set of rings and the correct bore size. A cylinder bore that is 0.001 inch (0.03 mm) under size will reduce the end gap 0.003 inch (0.08 mm).

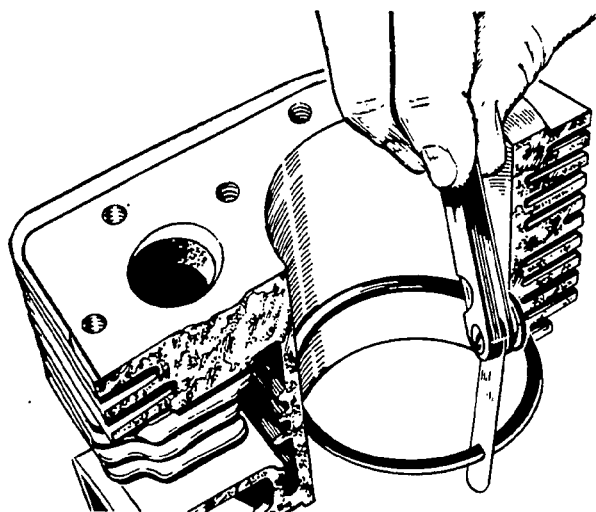
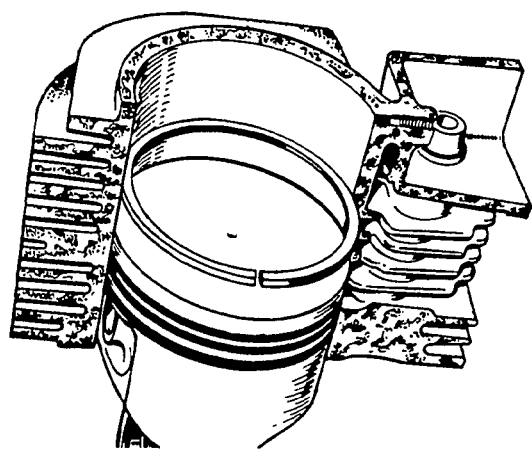

FIGURE 17. POSITIONING OF PISTON RING AND MEASURING OF END GAP

CYLINDER BLOCK

The cylinder block is the main support for all other basic engine parts. Crankshaft and camshaft are supported by the block, assuring alignment of the crankshaft and cylinder bores.

Cleaning

After removing pistons, crankshaft, cylinder heads, etc., inspect block for cracks and wear. If block is still serviceable, prepare it for cleaning as follows:

1. Scrape all old gasket material from block. Remove oil by-pass to allow cleaning solution to contact inside of oil passages.
2. Remove grease and scale from cylinder block by agitating in a bath of commercial cleaning solution or hot soapy washing solution.
3. Rinse block in clean hot water to remove cleaning solution.

Inspection

When rebuilding the engine, thoroughly inspect block for any condition that would make it unfit for further use. This inspection must be made after all parts have been removed and block has been thoroughly cleaned and dried.

1. Make a thorough check for cracks. Minute cracks may be detected by coating the suspected area with a mixture of 25 percent kerosene and 75 percent light motor oil. Wipe the part dry and immediately apply a coating of zinc oxide (white lead) dissolved in wood alcohol. If cracks are present, the white coating will become discolored at the defective area. Always replace a cracked cylinder block.
2. Inspect all machined surfaces and threaded holes. Carefully remove any nicks or burrs from machined surfaces. Clean out tapped holes and clean up any damaged threads.
3. Check top of block for flatness with a straight edge and a feeler gauge.

Cylinder Bore Inspection: Inspect cylinder bores for scuffing, scratches, wear, and scoring. If cylinder bores are scuffed, scratched, worn, or scored, they must be rebored and honed for the next oversize piston.

When the appearance of cylinder bores is good and there are no scuff marks, check cylinder bore for wear or out of roundness as follows:

1. Check cylinder bore for taper, out of round, and wear with a cylinder bore gauge, telescopic gauge, or inside micrometer. These measurements should be taken at four places: top and bottom of piston ring travel, parallel and perpendicular to axis of crankshaft (Figure 18).

2. Record measurements taken at top and bottom of piston travel as follows:

- A. Measure and record as "A" the cylinder bore diameter (parallel to crankshaft) near the top of cylinder bore.
- B. Measure and record as "B" cylinder bore diameter (parallel to crankshaft) at the bottom of piston travel.
- C. Measure and record as "C" cylinder bore diameter (perpendicular to crankshaft) near the top of cylinder bore.
- D. Measure and record as "D" cylinder bore diameter (perpendicular to crankshaft) at the bottom of piston travel.
- E. Reading "A" subtracted from reading "B" and reading "C" subtracted from reading "D" indicates cylinder taper.

If cylinder taper exceeds that specified in *DIMENSIONS AND CLEARANCES* rebore and hone cylinder to the next oversize.

- F. Reading "A" compared to reading "C" and reading "B" compared to reading "D" indicate whether or not cylinder is out of round. If out of round exceeds that specified in *DIMENSIONS AND CLEARANCES* the cylinders must be rebored and honed to the next oversize.

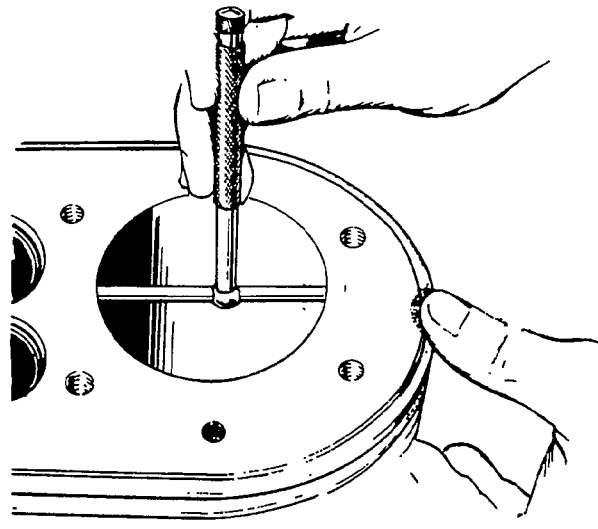
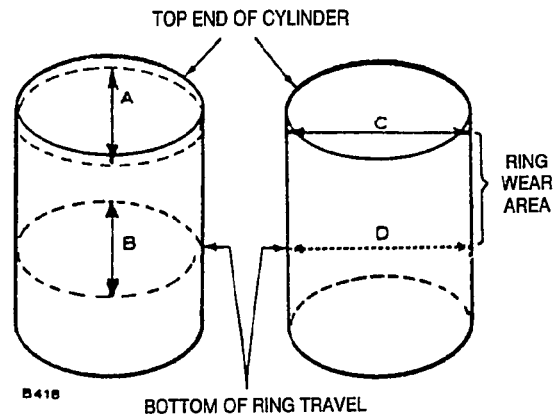

FIGURE 18. METHODS OF MEASURING THE DIAMETER OF A CYLINDER BORE

Reboring the Cylinder

Rebore and hone engine whenever cylinder bore is worn, damaged, out of round, or if cylinder taper exceeds specifications. A worn cylinder bore should be resized to the smallest standard oversize diameter at which it will clean up. The final finish and bore diameters should then be obtained by honing. Final bore diameter should equal the standard diameter added to the oversize.

CAUTION *Improper boring will result in engine damage. Boring must be done by qualified mechanics.*

After boring to the correct oversize cylinder bore dimension piston and ring clearance should be appropriate. There is no need to adjust or "fit" pistons and rings.

When reboring cylinders, take the following precautions:

1. Make sure cutting tool is properly ground before using it.
2. Be sure top of engine block is smooth and deposit free.

3. Clean base of boring bar before bar is set up. Deposits under boring bar will cause it to tilt and the cylinder will be distorted after boring.
4. Make an initial rough cut, followed by a finish cut. Then hone cylinder bore to the specified oversize.

Honing Cylinders (Using Precision Hones)

Refer to hone manufacturer's recommended grit size to produce specified surface finish of 20 to 40 RMS. Too rough of a finish will wear out the rings and too smooth of a finish can retard piston ring seating.

1. Position block solidly for either vertical or horizontal honing. Use either a drill press or heavy-duty drill which operates at approximately 250 to 450 rpm.
2. Follow hone manufacturer's instructions for the use of oil or lubricant on stones. Do not use lubricants with a dry hone.
3. Insert hone in bore and adjust stones to fit snugly to the narrowest section. When adjusted correctly, the hone should not shake or chatter in cylinder bore, but will drag freely up and down when hone is not running.
4. Connect drill to hone and start drill. Feel out bore for high spots, which cause an increased drag on stones. Move hone up and down in bore with short overlapping strokes about 40 times per minute. Usually bottom of cylinder must be worked out first because it is smaller. As cylinder takes a uniform diameter, move hone up and down all the way through cylinder bore.
5. Check diameter of the cylinder regularly during honing. A dial bore gauge is the easiest method but a telescoping gauge can be used. Check size at six places in bore: measure twice at top, middle and bottom at 90-degree angles.
6. Crosshatch formed by the stones should form an included angle of 23 degrees. This can be achieved by moving the rotating hone (250 to 450 rpm) up and down in cylinder bore about 40 times per minute.
7. Clean cylinder bores thoroughly with soap, water and clean rags. A clean white rag should not become soiled on wall after cleaning is complete. Do not use a solvent or gasoline since they wash oil from the walls but leave the metal particles.
8. Dry crankcase and coat it with oil.

Deglazing Cylinder Bores

Deglaze the cylinder bores if there are no scuff marks and no wear or out of round beyond specifications before installing new rings. Deglazing gives a fine finish, but does not enlarge cylinder diameter, so the original pistons with new rings may still be used.

The reason for deglazing a cylinder is to provide cavities to hold oil during piston ring break-in.

1. Wipe cylinder bores with a clean cloth which has been dipped in clean, light engine oil.
2. Use a brush type deglazing tool with coated bristle tips to produce a crosshatch pattern in the cylinder bore.
3. Use a slow speed drill to drive the deglazing tool. Move deglazing tool up and down in cylinder (10 to 12 complete strokes) rapidly enough to obtain a crosshatch pattern (Figure 19).

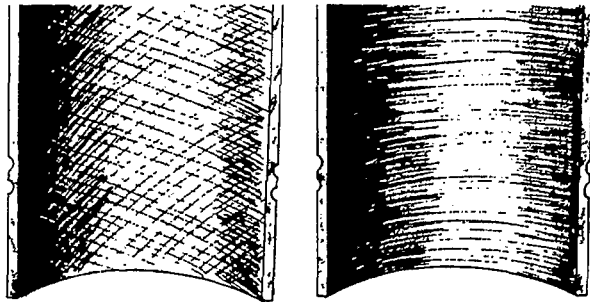

PRODUCE CROSSHATCH SCRATCHES FOR FAST RING SEATING

AVOID THIS FINISH

FIGURE 19. CROSSHATCHING

CAUTION

Improper cylinder cleaning will result in engine damage. Do not use gasoline, solvents, or commercial cleaners to clean cylinder bores.

4. Clean cylinder bore thoroughly with soap, water and clean rags. Continue cleaning until a clean white rag shows no discoloring when wiped through cylinder bore.

CRANKSHAFT

Clean crankshaft thoroughly and inspect journals for scoring, chipping, cracking, or signs of overheating. If crankshaft has overheated, is scored, or excessively worn, reconditioning or replacement will be required. Examine bearing journals for cracks if overheating has occurred.

Measure crankshaft main bearing and connecting rod journals at several places on their diameter to check for roundness and taper.

The only recommended method of reconditioning the crankshaft is regrinding, as required to accommodate undersize bearings. Metalizing of bearing journals is not recommended.

If regrinding of crankshaft journals is necessary, the work should be done by a reputable machine shop that has suitable equipment to handle precision work of this type. Undersize main bearings and connecting rods are available.

Whenever making major repairs on the engine, always inspect the drilled passages of the crankshaft. Clean them to remove any foreign material and to assure proper lubrication of the connecting rods.

BEARINGS

With camshaft and crankshaft removed, use a micrometer to measure diameter of bearing journals. Use a dial bore gauge or a telescopic gauge and micrometer to measure inside diameter of bearings. Refer to *DIMENSIONS AND CLEARANCES* to determine if clearances are within specifications.

Any bearing that is scored, chipped, pitted or worn beyond the specified limits must be replaced.

Removal of the camshaft bearings requires complete disassembly of the engine. Use a press or a suitable driver to remove bearings. Support casting to avoid distortion and to avoid damaging the bearing bore during removal and installation.

Replacement camshaft bearings are precision type which do not require line reaming or line boring after installation. Clean outside of the bearing and bearing bore in the block. Before installing cam bearings use Loctite Bearing Mount on outside diameter of bearing. Use a combination bearing driver to install bearings.

Place the bearing on the crankcase over the bearing bore with the lubricating hole (front only) in the proper position. Be sure to start the bearing straight. Press in the front bearing flush with the outside end of the bearing bore. Front cam bearing oil hole must line up with oiling hole in cylinder block (Figure 20). Press in the rear camshaft bearing to the dimension shown (Figure 20). Lubricate bearing surfaces with oil after installing.

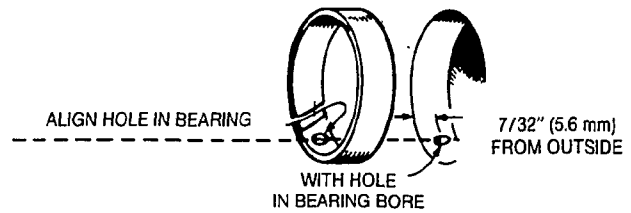

FRONT CAMSHAFT BEARING

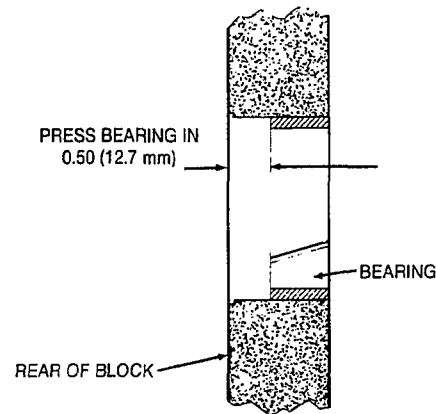

REAR CAMSHAFT BEARING

CT-1088

FIGURE 20. CAMSHAFT BEARINGS

New crankshaft main bearings are precision type which do not require line reaming or line boring after installation. Use a press or a suitable driver to remove bearings. Support casting to avoid distortion and to avoid damaging the bearing bore during removal and installation.

Before installing main bearings, expand bearing bore by placing the casting in an oven heated to 200°F (94°C). If practical, cool the precision bearing to shrink it.

Before installing the front main bearing, use the towelette included with the bearing kit to clean the outside of the bearing and bearing bore in the block.

▲WARNING Breathing vapor from towelette and prolonged contact with skin can be harmful. Use only in well ventilated area and avoid prolonged contact with skin.

After allowing three to four minutes for drying, apply the Loctite from the small tube to the mating surfaces of the bearing and the bearing bore. Align the oil holes in the bearing with the oil holes in the bearing bore (Figure 22). The oil passage should be at least half open. Install the bearing flush with the block, using the combination driver. Wipe off excess Loctite around the bearing. Allow at least one hour for hardening at room temperature.

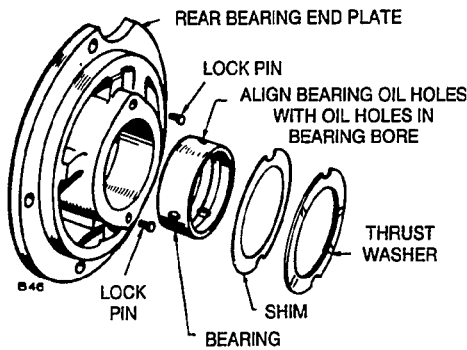

FIGURE 21. BEARINGS FOR REAR BEARING PLATE

Engines shipped from the factory have separate thrust washers and main bearings for both front and rear of engine. Front bearing replacement part is a one piece bearing (with attached thrust washer) as shown in Figure 22. Do not add an additional thrust washer to this front bearing.

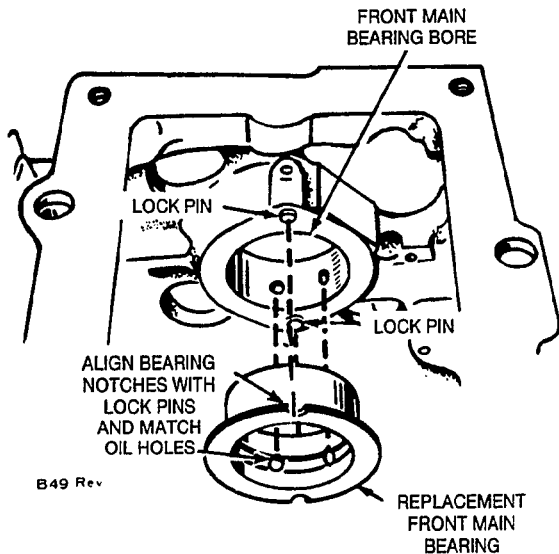

FIGURE 22. FRONT BEARING INSTALLATION

In the rear bearing plate, install the bearing flush to 1/64 inch (0.40 mm) below the end of the bore. Be sure to align the oil holes in the bearing with the oil holes in the bearing bore (Figure 21). The oil passage must be at least half open. Lubricate bearing after installation.

If head of lock pin is damaged, use side cutters or Easy Out tool to remove and install new pin. Oil grooves in thrust washers must face the crankshaft, and washers must be flat (not bent). The two notches on each washer must fit over the two lock pins to prevent riding on the crankshaft (Figure 21).

Lubricate the front main bearing lightly with oil and insert the crankshaft. With the rear bearing plate gasket in place and the rear plate bearing lubricated, slide the thrust washer (grooves toward crankshaft) and plate over the end of the crankshaft. A light film of oil on the thrust washer may hold it in place while installing bearing plate over crankshaft. Line up notches of thrust washer with lock pins before tightening end plate or lock pins will be damaged.

CRANKSHAFT ENDPLAY

After the rear bearing end plate has been tightened, using the torque recommended in *ASSEMBLY TORQUES AND SPECIAL TOOLS*, check the crankshaft endplay (Figure 23). If there is too much endplay (see *DIMENSIONS AND CLEARANCES* for minimum and maximum endplay), remove the rear bearing end plate and add a shim (Figure 21) between the thrust washer and plate. Reinstall the end plate, making sure the thrust washer and shim notches line up with the lock pins. Torque and recheck endplay of the crankshaft.

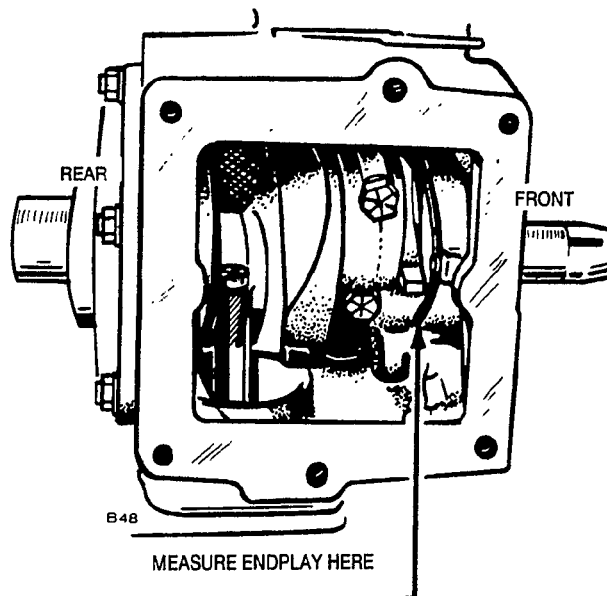

FIGURE 23. CRANKSHAFT ENDPLAY

CHECKING CONNECTING ROD BEARING CLEARANCE WITH PLASTIGAUGE

1. Make certain that all parts are marked or identified so they are installed in their original positions. Using a clean dry cloth, thoroughly clean all oil from crankshaft journal and connecting rod. If connecting rod bearing inserts are being replaced (P224 only), install them in rod and cap.
2. Place a piece of correct size Plastigauge in the bearing cap the full width of the journal surface and about 1/4 inch (6.35 mm) off center (Figure 24).
3. Rotate the crankshaft about 30 degrees from bottom dead center and reinstall the bearing cap; tighten rod bolts to the torque specified in *ASSEMBLY TORQUES AND SPECIAL TOOLS*. Do not turn the crankshaft.
4. Remove bearing cap. The flattened Plastigauge will be found adhering to either the bearing cap or crankshaft.
5. Compare flattened Plastigauge with the graduations on Plastigauge envelope to determine clearance.

The number within the matching graduation on the envelope indicates total clearance in millimeters or thousandths of an inch.

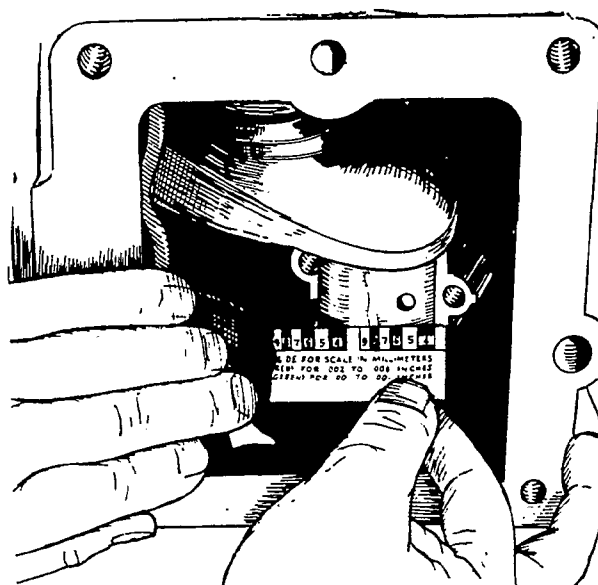

FIGURE 24. MEASURING BEARING CLEARANCE

OIL SEALS

The bearing plate must be removed to replace the oil seal (Figure 25). Drive the oil seal out from the inside.

Before installing seals, fill the space between lips with a multi-purpose grease. This will improve sealing.

When installing the gear cover oil seal, tap the seal inward until it is .645 inch (16.4 mm) from the front of the gear cover.

When installing the bearing plate oil seal, tap the seal into the bearing plate bore to bottom against the shoulder in the plate bore. Use a seal expander or place a piece of heavy paper around the end of the crankshaft, when replacing the bearing plate to avoid damaging the seal. Remove the paper as soon as the plate is in place.

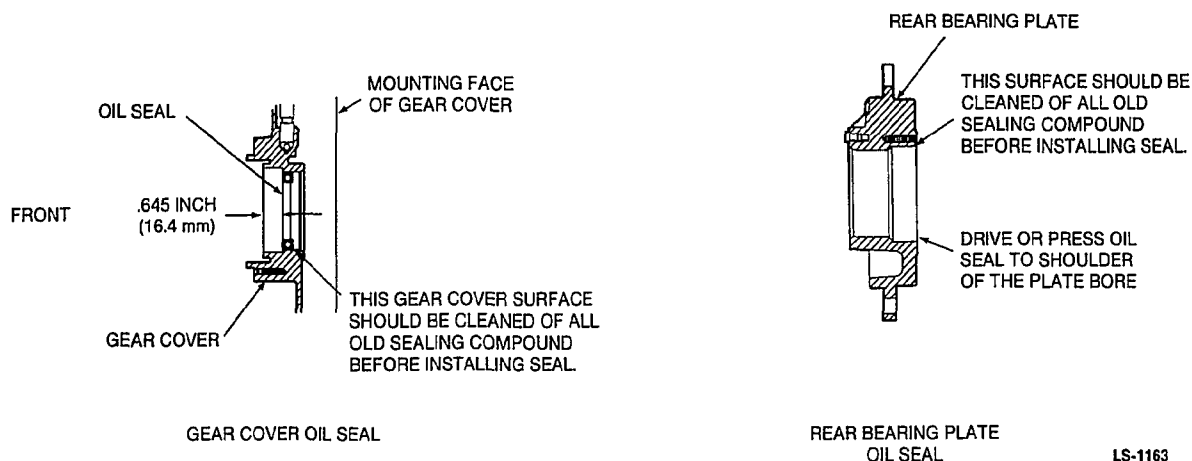

FIGURE 25. GEAR COVER AND REAR BEARING PLATE OIL SEALS

LS-1163

PISTON ASSEMBLY

1. Lubricate all parts with engine oil.
2. Position piston on its respective rod and install the pin.
3. Install the rings on the pistons starting with the oil control ring (Figure 26). Use a piston ring spreader to prevent twisting or excessive expansion of the ring. Compression rings have a dot or the word "top" on one side of the ring to indicate which side faces the top of the piston. Unmarked piston rings can be installed either way. The oil control ring has an expander; install the expander first and then close until the expander ends butt. The joint should be 180 degrees from the gap of that ring.

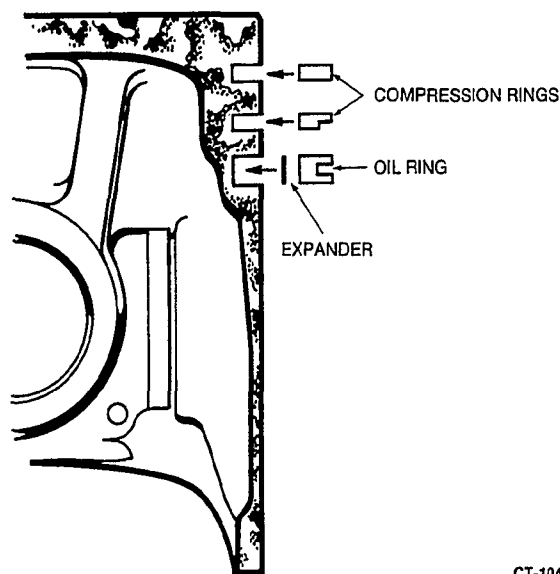

FIGURE 26. PISTON RINGS

INSTALLATION OF PISTON IN CYLINDER

1. Turn the crankshaft to position the number one rod bearing journal at the bottom of its stroke.
2. Lubricate the number one piston assembly and inside of the cylinder. Compress the rings with a ring compressor (Figure 27).
3. Position the piston and rod assembly in the cylinder block. Oil squirt hole of connecting rod must face camshaft.
4. Tap the piston down into the bore with the handle end of a hammer until the connecting rod is seated on the journal (Figure 27). Install the bearing cap on the rod.

P216, P218, P220

Install one fastener and tighten to 5 ft-lbs (7 Nm). Repeat this for the other fastener. Tighten both fasteners down to the torque specified in *ASSEMBLY TORQUES*.

P224

Install and tighten the nuts evenly in steps, to the torque specified in *ASSEMBLY TORQUES*.

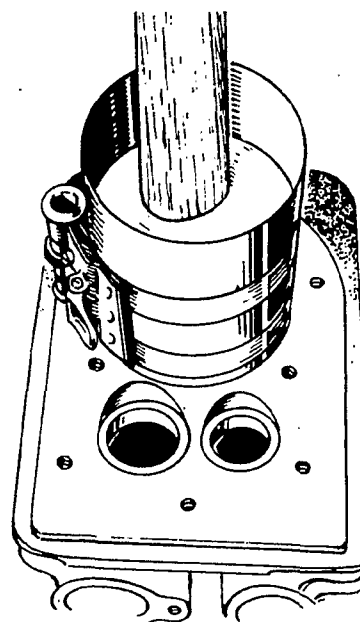
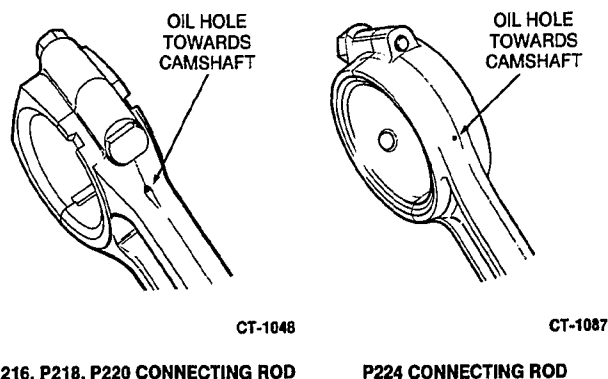

FIGURE 27. INSTALLING PISTON AND CONNECTING ROD

5. Install the remaining piston and rod in the same manner. Crank the engine over by hand to see that all bearings are free.
6. Install the oil base with a new gasket.
7. Install the cylinder heads. See *Cylinder Head* section for torques and torquing procedure.
8. Replace oil and break in engine.

CYLINDER HEADS

Remove the cylinder heads for carbon cleaning and gasket change at intervals specified in the *Periodic Maintenance Schedule* (located in the Operator's Manual).

1. Use a 1/2 inch (13 mm) socket wrench to remove cylinder head bolts or nuts. Lift heads off.

CAUTION *Torquing or removing cylinder heads when hot (above 100° F [37° C]) will result in head damage. Allow heads to cool to below 100° F (37° C) before torquing or removing.*

2. After removing heads, clean out all carbon deposits. Be careful not to damage the outer sealing edges where gaskets fit. The heads are made of aluminum and can be damaged by careless handling.

3. Use new head gaskets and clean both the heads and the cylinder block thoroughly where the head gaskets rest.

P216, P218, P220 Installation

1. Place a head gasket on the cylinder block and align the holes in the gasket with the holes in the cylinder block. While holding the gasket against the cylinder head, carefully install the cylinder head on the engine. Do not attempt to slide the head bolts through the gasket without the cylinder block behind it or the gasket may tear.
2. Follow the head torque sequence shown in Figure 28. Tighten all bolts to 5 ft-lbs (7 Nm), then 10 ft-lbs (14 Nm), then to the torque specified in *ASSEMBLY TORQUES*. Recheck all head bolts for correct torque.

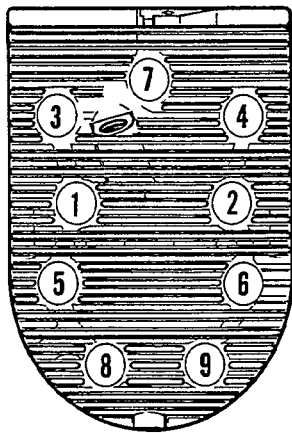

NO. 1 CYLINDER (LH)

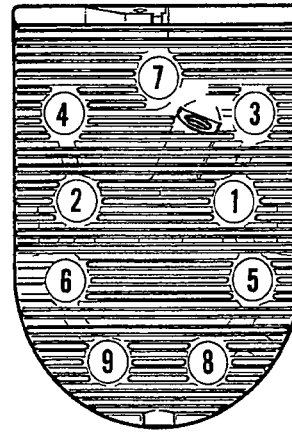

NO. 2 CYLINDER (RH)

FIGURE 28. CYLINDER HEAD TORQUE SEQUENCE

C-1002

P224 Installation

1. Place a head gasket on the cylinder head and align the stud holes in the gasket with the stud holes in the cylinder head. While holding the gasket against the cylinder head, carefully install the cylinder head on the engine. Do not attempt to slide the gasket over the studs without the cylinder head behind it or the gasket may tear.
2. Install a flat washer, two compression washers, and nut on each of the top six studs (Figure 29 for correct sequence). When properly installed, only the outside edges of the compression washers will be in contact with each other. Install a flat washer and nut on each of the four bottom studs.

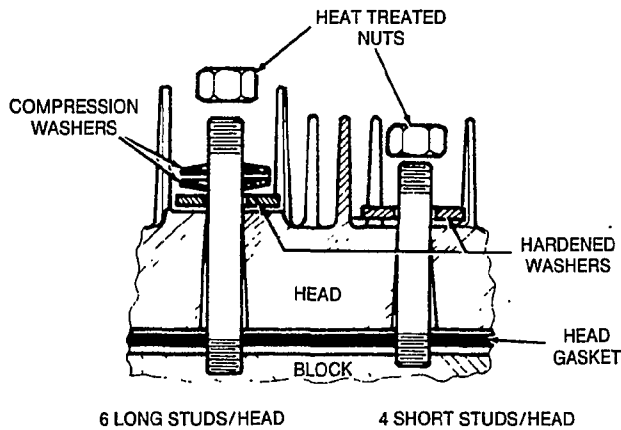

FIGURE 29. CYLINDER HEAD WITH COMPRESSION WASHERS

CAUTION Over torquing nuts can cause engine damage. Do not over torque nuts.

3. Follow the head torque sequence shown in Figure 30. Tighten all nuts to 5 ft-lbs (7 Nm), then 10 ft-lbs (14 Nm), then to the torque specified in **ASSEMBLY TORQUES**. Recheck all nuts for correct torque.

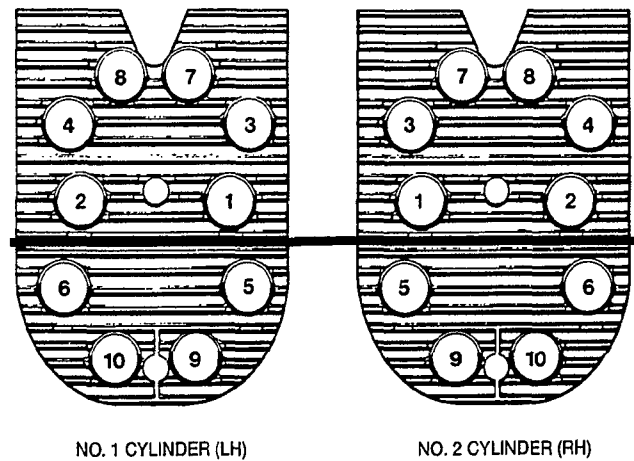

FIGURE 30. CYLINDER HEAD TORQUE SEQUENCE

4. Recheck torque when the engine has run a total of 50 hours.



Cummins Power Generation
1400 73rd Avenue N.E.
Minneapolis, MN 55432
763-574-5000
Fax: 763-574-8087

Cummins and Onan are registered trademarks of Cummins Inc.