

Onan

**Service
Manual**

**T-260G
Engine**

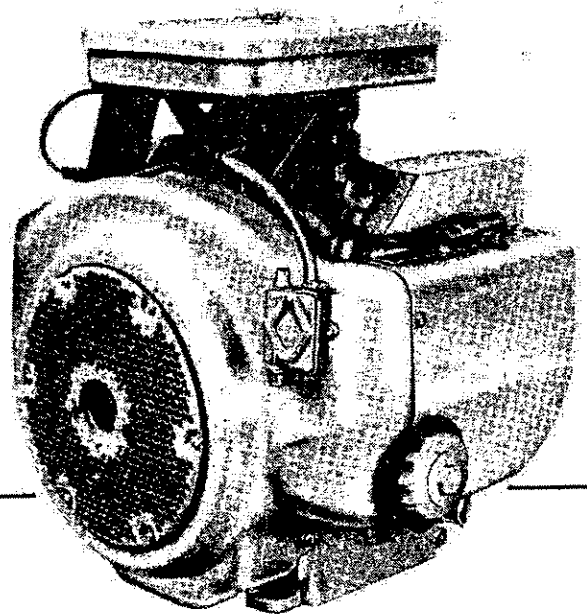

965-0760
(Spec A-F)
6-87
Printed in U.S.A.

Table of Contents

TITLE	PAGE
General Information	1-1
Specifications	2-1
Dimensions and Clearances	3-1
Assembly Torques and Special Tools	4-1
Engine Troubleshooting	5-1
Oil System	6-1
Fuel System	7-1
Ignition and Battery Charging	8-1
Starting System	9-1
Engine Disassembly	10-1

▲WARNING

EXHAUST GAS IS DEADLY!

Exhaust gases from all fuels (including diesel, gasoline, liquid propane, natural gas) contain carbon monoxide, an odorless and colorless gas. Carbon monoxide is poisonous and can cause unconsciousness and death. Symptoms of carbon monoxide poisoning can include:

- *Dizziness*
- *Nausea*
- *Headache*
- *Weakness and Sleepiness*
- *Throbbing in Temples*
- *Muscular Twitching*
- *Vomiting*
- *Inability to Think Coherently*

IF YOU OR ANYONE ELSE EXPERIENCE ANY OF THESE SYMPTOMS, GET OUT INTO THE FRESH AIR IMMEDIATELY. If symptoms persist, seek medical attention. Shut down the unit and do not operate until it has been inspected and repaired.

Protection against carbon monoxide inhalation includes proper installation, ventilation and regular, frequent visual and audible inspections of the complete exhaust system.

General Information

INTRODUCTION

This manual deals with specific mechanical and electrical information needed by engine mechanics for troubleshooting, servicing, repairing, or overhauling the engine.

Use the table of contents for a quick reference to the separate engine system sections.

Use the separate Parts Catalogs available at the dealer level, for parts identification and for establishing their proper location on assemblies.

The troubleshooting guide is provided as a quick reference for locating and correcting engine trouble.

The illustrations and procedures presented in each section apply to the engines listed on the cover. The flywheel-blower end of the engine is the front end so right and left sides are determined by viewing the engine from the front.

The disassembly section contains major overhaul procedures for step by step removal, disassembly, inspection, repair and assembly of the engine components.

If a major repair or an overhaul is necessary, a competent mechanic should either do the job or supervise and check the work of the mechanic assigned to do the job to ensure that all dimensions, clearances and torque values are within the specified tolerances.

The wiring diagram on the last page of the manual shows how the electrical components are interconnected.

A parts catalog (available at the dealer level) contains detailed exploded views of each assembly and the individual piece part numbers and their proper names for ordering replacement parts.

Use only Genuine Onan replacement parts to ensure quality and the best possible repair and overhaul results. When ordering parts, always use the complete Model and Spec number as well as the Serial number shown on the nameplate.

ENGINE MODEL REFERENCE

Identify your model by referring to the MODEL and SPEC (specification) NO. as shown on the unit nameplate. Always use this number and the engine serial number when making reference to your engine.

How to Interpret MODEL and SPEC NO.

T	2	60	G	G	A	024	/	1	A
1	2	3	4	5	6	7		8	9

1. Factory code for general identification of basic engine series.
2. Number of cylinders.
3. Cubic inch displacement.
4. Engine duty cycle.
5. Fuel required (G=gasoline).
6. Cooling system description - (A=air-cooling-pressure).
7. BHP rating.
8. Factory code for designated optional equipment, if any.
9. Specification (spec letter) which advances with factory production modifications.

⚠WARNING

INCORRECT SERVICE OR REPLACEMENT OF PARTS CAN RESULT IN SEVERE PERSONAL INJURY AND/OR EQUIPMENT DAMAGE. SERVICE PERSONNEL MUST BE QUALIFIED TO PERFORM ELECTRICAL AND/OR MECHANICAL SERVICE.

Specifications

This manual contains SI metric equivalents that follow immediately in parentheses after the U.S. customary units of measure.

SPECIFICATION	UNIT OF MEASURE	SERIES
		T-260G
Number of Cylinders		2
Bore	in (mm)	3.56 (90.48)
Stroke	in (mm)	3.0 (76)
Displacement	cu in (cm ³)	60 (983)
Compression Ratio		7.0 to 1
Rated Speed (Maximum)	RPM	3600
Power at Rated Speed	BHP (kW)	24 (17.9)
Oil Filter		Full Flow
Oil Capacity Without Filter	Qt (litre)	2.5 (2.4)
Oil Capacity With Filter Change	Qt (litre)	3.0 (2.8)
Crankshaft Rotation (viewed from flywheel)		Clockwise
Governor		Variable Speed Mechanical
Valve Clearance (Cold)		
Intake	in (mm)	.005 (0.13)
Exhaust	in (mm)	.013 (0.33)
Spark Plug Gap	in (mm)	.025 (0.64)
Breaker Point Gap - Static (Spec A-E) (Full Separation and Engine Cold)	in (mm)	.020 (0.51)
Ignition Timing	BTC	20°
Cylinder Compression	psi (kPa)	75 to 115 517 to 793

Dimensions and Clearances

All clearances given at room temperature of 70°F (21°C). All dimensions in inches (approximate millimetre dimensions in parentheses) unless otherwise specified.

DESCRIPTION	MINIMUM		MAXIMUM	
	Inches	(mm)	Inches	(mm)
CYLINDER BLOCK				
Cylinder Bore Honed Diameter	3.5625	(90.49)	3.5635	(90.51)
Maximum Allowable				
Taper			0.003	(0.08)
Out-of-Round			0.003	(0.08)
Main Bearing Inside Diameter (Without bearing)	2.187	(55.55)	2.188	(55.58)
Main Bearing Inside Diameter (Installed)	2.0015	(50.84)	2.0040	(50.90)
Camshaft Bearing Bore (Bearing Installed)	1.3760	(34.95)	1.3770	(34.98)
Interference Stud Height from Top Surface of Block				
Spec C, D, E				
Top 2	2.00	(50.80)	2.06	(52.32)
Middle 4	1.84	(46.74)	1.90	(48.26)
Bottom 4	1.16	(29.46)	1.22	(30.99)
CRANKSHAFT				
Main Bearing Journal Diameter	1.9992	(50.78)	2.0000	(50.80)
Main Bearing Clearance				
Spec A-E	0.0025	(0.064)	0.0038	(0.097)
Begin Spec F	0.0024	(0.061)	0.0042	(0.107)
Connecting Rod Journal Diameter	1.6252	(41.28)	1.6260	(41.30)
Crankshaft End Play	0.005	(0.13)	0.009	(0.23)
CONNECTING ROD				
Large Bore Diameter (Without bearing installed and rod bolts properly torqued)	1.7505	(44.46)	1.7510	(44.48)
Connecting Rod Side Clearance	0.0020	(0.051)	0.0160	(0.406)
Piston Pin Bushing Bore (Without bearing)	0.8115	(20.61)	0.8125	(20.64)
Piston Pin Bushing Bore with Bearing, (Finished bore)	0.7504	(19.06)	0.7508	(19.07)
Bearing to Crankshaft Clearance				
Aluminum Rod	0.0020	(0.051)	0.0033	(0.084)
Iron Rod	0.0020	(0.051)	0.0033	(0.084)
CAMSHAFT				
Bearing Journal Diameter	1.3740	(34.90)	1.3745	(34.91)
Bearing Clearance	0.0015	(0.038)	0.0030	(0.076)
End Play				
Spec A-E	0.0030	(0.076)	0.0120	(0.305)
Begin Spec F	0.011	(0.28)	0.048	(1.22)
Camshaft Lift				
Intake				
Begin Spec A	0.286	(7.26)	0.294	(7.47)
Begin Spec E	0.285	(7.24)	0.293	(7.44)
Begin Spec F		0.305	(7.75)	
Exhaust				
Begin Spec A	0.291	(7.39)	0.299	(7.59)
Begin Spec E	0.283	(7.19)	0.291	(7.39)
Begin Spec F		0.295	(7.49)	

DESCRIPTION	MINIMUM		MAXIMUM	
	Inches	(mm)	Inches	(mm)
PISTON				
Clearance in Cylinder	0.0070	(0.178)	0.0090	(0.229)
Measure 1.187 Below Top of Piston and 90° from pin	0.7502	(19.055)	0.7506	(19.065)
Piston Pin Bore				
Ring Groove Width	0.080	(2.032)	0.081	(2.057)
Top 1 Compression Ring	0.080	(2.032)	0.081	(2.057)
No. 2 Compression Ring	0.188	(4.775)	0.189	(4.801)
No. 3 Oil Control Ring				
PISTON PIN				
Clearance in Piston	0.0001	(0.003)	0.0005	(0.013)
Clearance in Connecting Rod				
Aluminum Rod	0.0002	(0.005)	0.0008	(0.020)
Iron Rod	0.0002	(0.005)	0.0008	(0.020)
Diameter	0.7500	(19.05)	0.7502	(19.06)
PISTON RINGS				
Clearance	0.002	(0.051)	0.008	(0.203)
Top Groove	0.010	(0.254)	0.020	(0.508)
Ring End Gap in Cylinder				
INTAKE VALVE				
Stem Diameter	0.3425	(8.70)	0.3430	(8.71)
Clearance (Stem to Guide)	0.0010	(0.025)	0.0025	(0.064)
Valve Face Angle		44°		
INTAKE VALVE SEAT				
Seat Cylinder Head Bore Diameter	1.5645	(39.74)	1.5655	(39.76)
Seat Outside Diameter	1.5690	(39.85)	1.5700	(39.88)
Valve Seat Width	0.031	(0.787)	0.047	(1.194)
Valve Seat Angle		45°		
EXHAUST VALVE				
Stem Diameter	0.3410	(8.661)	0.3420	(8.687)
Clearance (Stem to Guide)	0.0025	(0.064)	0.040	(0.101)
Valve Face Angle		44°		
EXHAUST VALVE SEAT				
Seat Cylinder Head Bore Diameter	1.2510	(31.78)	1.2520	(31.80)
Seat Outside Diameter	1.2550	(31.88)	1.2560	(31.90)
Valve Seat Width	0.031	(0.787)	0.047	(1.194)
Valve Seat Angle		45°		
VALVE GUIDE				
Inside Diameter	0.344	(8.74)	0.346	(8.79)
TAPPET				
Body Diameter	0.7475	(18.99)	0.7480	(19.00)
Bore Diameter	0.7500	(19.05)	0.7515	(19.09)
Clearance in Bore	0.0015	(0.038)	0.003	(0.076)
VALVE SPRINGS INTAKE AND EXHAUST				
Valve Spring Free Length (Approx.)		1.662	(42.21)	
Valve Spring Length				
Valve Open		1.125	(28.58)	
Valve Closed		1.375	(34.93)	
Spring Load @ 1.375 inch (Valve Closed)	38 lb.	(17 kg)	42 lb.	(19 kg)
Spring Load @ 1.125 inch (Valve Open)	71 lb.	(32 kg)	79 lb.	(36 kg)

DESCRIPTION	MINIMUM		MAXIMUM	
	Inches	(mm)	Inches	(mm)
PISTON				
Clearance in Cylinder	0.0070	(0.178)	0.0090	(0.229)
Measure 1.187 Below Top of Piston and 90° from pin	0.7502	(19.055)	0.7506	(19.065)
Piston Pin Bore				
Ring Groove Width	0.080	(2.032)	0.081	(2.057)
Top 1 Compression Ring	0.080	(2.032)	0.081	(2.057)
No. 2 Compression Ring	0.188	(4.775)	0.189	(4.801)
No. 3 Oil Control Ring				
PISTON PIN				
Clearance in Piston	0.0001	(0.003)	0.0005	(0.013)
Clearance in Connecting Rod				
Aluminum Rod	0.0002	(0.005)	0.0008	(0.020)
Iron Rod	0.0002	(0.005)	0.0008	(0.020)
Diameter	0.7500	(19.05)	0.7502	(19.06)
PISTON RINGS				
Clearance	0.002	(0.051)	0.008	(0.203)
Top Groove	0.010	(0.254)	0.020	(0.508)
Ring End Gap in Cylinder				
INTAKE VALVE				
Stem Diameter	0.3425	(8.70)	0.3430	(8.71)
Clearance (Stem to Guide)	0.0010	(0.025)	0.0025	(0.064)
Valve Face Angle			44°	
INTAKE VALVE SEAT				
Seat Cylinder Head Bore Diameter	1.5645	(39.74)	1.5655	(39.76)
Seat Outside Diameter	1.5690	(39.85)	1.5700	(39.88)
Valve Seat Width	0.031	(0.787)	0.047	(1.194)
Valve Seat Angle			45°	
EXHAUST VALVE				
Stem Diameter	0.3410	(8.661)	0.3420	(8.687)
Clearance (Stem to Guide)	0.0025	(0.064)	0.040	(0.101)
Valve Face Angle			44°	
EXHAUST VALVE SEAT				
Seat Cylinder Head Bore Diameter	1.2510	(31.78)	1.2520	(31.80)
Seat Outside Diameter	1.2550	(31.88)	1.2560	(31.90)
Valve Seat Width	0.031	(0.787)	0.047	(1.194)
Valve Seat Angle			45°	
VALVE GUIDE				
Inside Diameter	0.344	(8.74)	0.346	(8.79)
TAPPET				
Body Diameter	0.7475	(18.99)	0.7480	(19.00)
Bore Diameter	0.7500	(19.05)	0.7515	(19.09)
Clearance in Bore	0.0015	(0.038)	0.003	(0.076)
VALVE SPRINGS INTAKE AND EXHAUST				
Valve Spring Free Length (Approx.)			1.662	(42.21)
Valve Spring Length			1.125	(28.58)
Valve Open			1.375	(34.93)
Valve Closed				
Spring Load @ 1.375 inch (Valve Closed)	38 lb.	(17 kg)	42 lb.	(19 kg)
Spring Load @ 1.125 inch (Valve Open)	71 lb.	(32 kg)	79 lb.	(36 kg)

DESCRIPTION	MINIMUM		MAXIMUM	
	Inches	(mm)	Inches	(mm)
GEAR BACKLASH				
Timing Gear				
Spec A-E	0.002	(0.051)	0.003	(0.076)
Begin Spec F	0.001	(0.025)	0.005	(0.127)
Oil Pump Gear				
Spec A-E	0.002	(0.051)	0.005	(0.127)
Begin Spec F	0.001	(0.025)	0.008	(0.203)
GOVERNOR				
Dashpot to Governor Arm Bracket	0.040	(1.02)	0.060	(1.52)

Assembly Torques

The torque values given in Table 1 have been determined for the specific applications. Standard torque values must not be used where those listed in Table 1 apply. The engine assembly torques given here will assure proper tightness without danger of stripping threads. All threads must be clean and lubricated with new engine oil before torquing.

Check all studs, nuts, and capscrews, and tighten as required to keep them from working loose. Refer to the *PARTS MANUAL* for the location of washers and capscrews.

TABLE 1.

DESCRIPTION	TORQUE SPECIFICATION		DESCRIPTION	TORQUE SPECIFICATION	
	Ft.-Lb.	Nm		Ft.-Lb.	Nm
Cylinder Head Nuts (with Compression Washers)			Gear Case Cover	8-10	(11-14)
Spec A-E	11-13	(15-18)	Oil Pump	7-9	(10-12)
Begin Spec F	14	(19)	Intake Manifold Mounting Screws	20-23	(27-31)
Cylinder Head Nuts (without Compression Washers)			Valve Cover	4-8	(5-11)
Spec A-E	14-16	(19-22)	Exhaust Manifold Mounting Screws		
Begin Spec F	17	(23)	Spec A-E	20-23	(27-31)
Rear Bearing Plate	25-28	(34-38)	Begin Spec F	9-11	(12-15)
Connecting Rod Bolt			Other 1/4" Cylinder Block Studs and Nuts	7-9	(10-12)
Spec A-E	14-16	(19-22)	Other 5/16" Cylinder Block Studs and Nuts	8-10	(11-13)
Begin Spec F	27-29	(37-39)	Other 3/8" Cylinder Block Nuts	18-23	(24-31)
Flywheel Capscrew	50-55	(67-75)			
Starting Mounling Bracket to Oil Base Screws	24-26	(33-35)			

Special Tools

The following special tools are available from Onan. For further information see *TOOL CATALOG 900-0019*.

- Valve Seat Driver*
- Valve Guide Driver*
- Oil Guide and Driver*
- Combination Bearing Remover (Main and Cam)*
- Combination Bearing Driver (Main and Cam)*
- Flywheel Puller*

Oil System

CRANKCASE OIL

Refer to engine nameplate or *Periodic Maintenance Schedule*, located in the Operator's Manual, for oil change interval. If operating in extremely dusty, high ambient, or low ambient conditions change oil more often.

Run engine until thoroughly warm before draining oil. Stop the engine, place a pan under the drain outlet and remove the oil drain plug or open the drain valve. After the oil is completely drained, replace the drain plug or close the drain valve. Refill with oil of the correct API classification and appropriate SAE viscosity grade for the temperature conditions.

Oil must meet or exceed the API designation SF, SF/CC, or SF/CD. Refer to the chart to determine the proper viscosity grade of oil to use. Straight weight oils are recommended for severe duty use and at temperatures above 32° F (0°C) for minimum oil consumption.

WARNING Crankcase pressure can blow out hot oil and cause serious burns. Do NOT check oil while the engine is operating.

WARNING Hot crankcase oil can cause burns if it is spilled or splashed on skin. Keep fingers and hands clear when removing the oil drain plug and wear protective clothing.

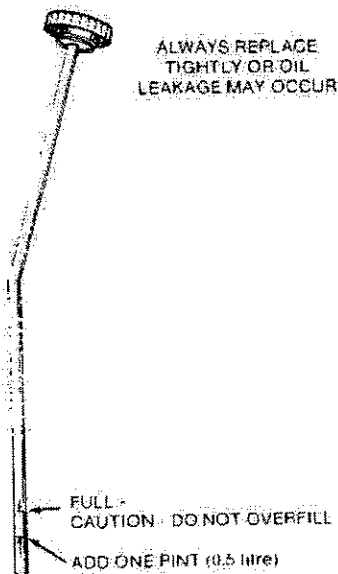
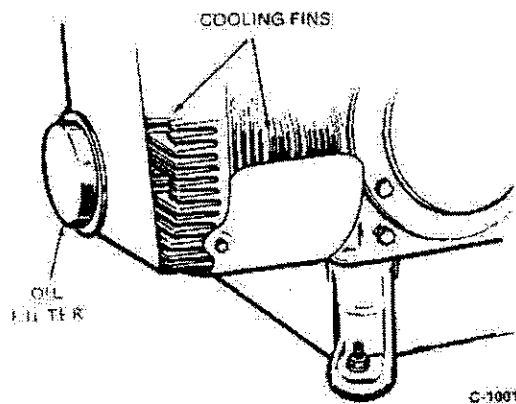
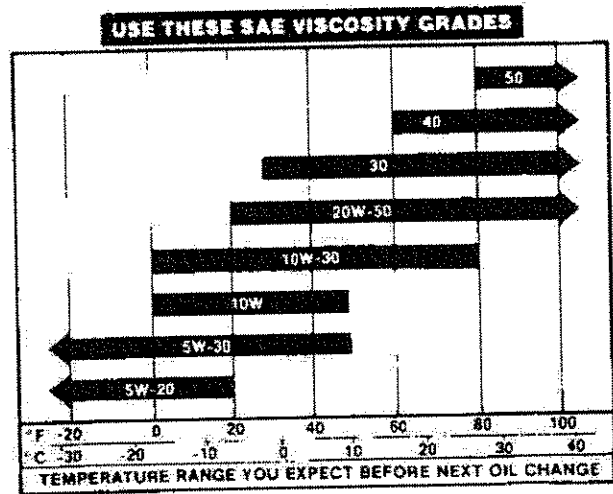

FIGURE 1. CRANKCASE OIL FILL

CAUTION Do not overfill crankcase. Excess oil causes higher operating temperatures and may cause foaming.

Oil level should be to the FULL mark of the dipstick. Start engine and run for a short time to check for oil leaks around the drain plug.



OIL FILTER CHANGE

Refer to engine nameplate or *Periodic Maintenance Schedule*, located in the Operator's Manual, for oil filter change interval. If operating in extremely dusty, high ambient, or low ambient conditions change oil more often.

Spin off oil filter element and discard it. Thoroughly clean filter mounting surface and make sure new gasket is inserted in the element.

Apply a thin film of oil to the gasket. Spin element down by hand until gasket just touches mounting pad and then turn down an additional 1/2-3/4 turn. Do not overtighten.

With oil in crankcase, start engine and check for leaks around filter element. Retighten only as much as necessary to eliminate leaks; do not overtighten.

CRANKCASE BREATHER

The crankcase breather prevents pressure from building up in the crankcase. It also prevents oil contamination by removing moisture or gasoline vapors and other harmful blow-by materials from the crankcase. These vapors are routed to the carburetor where they are mixed with incoming air and burned in the combustion chamber. A sticky breather valve can cause leaks, high oil consumption, rough idle, reduced engine power and a rapid formation of sludge and varnish within the engine.

Crankcase Breather Service

This engine uses a crankcase breather valve for maintaining crankcase vacuum. If the crankcase becomes pressurized as evidenced by oil leaks at the seals, clean baffle and valve in a suitable solvent.

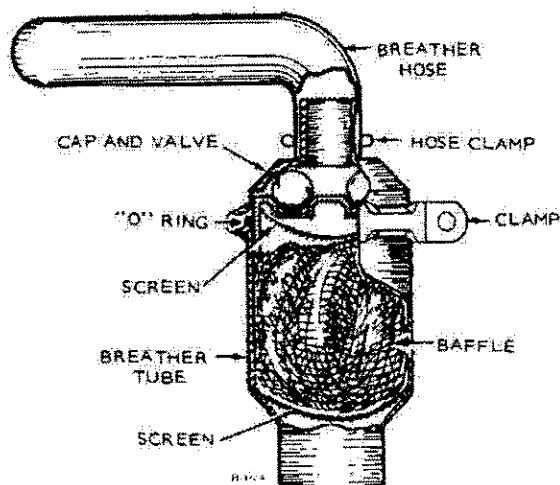

FIGURE 3. CRANKCASE BREATHER

Clean or replace crankcase breather baffle periodically. Be sure baffle material doesn't come apart and work into the manifold.

To disassemble, remove breather hose from cap and valve assembly. Remove cap and valve assembly and wash in a suitable solvent. Replace cap and valve if balls do not move freely. Pull baffle out and wash in solvent. To allow free operation of the valve, screens must be positioned as shown in Figure 3.

PRESSURE LUBRICATION

All engines use an oil pump to provide a constant flow of oil to the engine parts. The oil supply collects in the oil base where it is picked up by the oil pump pick-up cup. A by-pass valve is used to control oil pressure. Drain oil before removing oil base and always use a new gasket when replacing the oil base.

Oil Pump

The oil pump (Figure 4) is mounted behind the gear cover and is driven by the crankshaft gear. Inlet pipe and screen assembly are attached directly to the pump body. A discharge passage in pump cover registers with a drilled passage in the crankcase. Parallel passages distribute oil to the front main bearing, rear main bearing, and pressure control bypass valve.

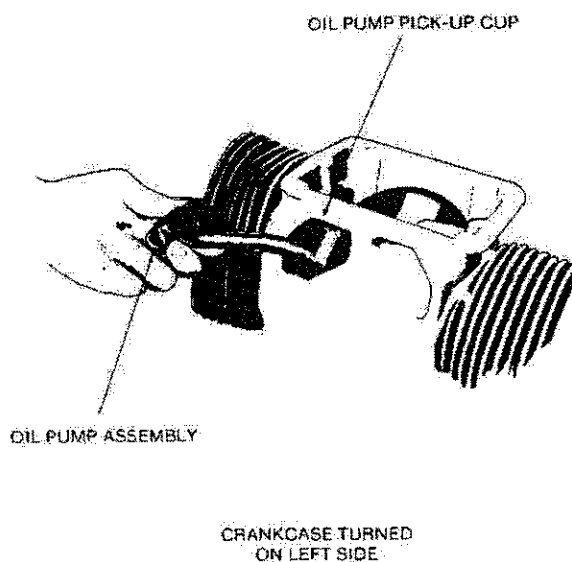

FIGURE 4. OIL PUMP ASSEMBLY

LS-1109

Circumferential grooves in the main bearings supply oil to connecting rod bearings through drilled passages from each main journal. A drilled passage connects the front main bearing oil supply to the front camshaft bearing; rear cam bearing is splash lubricated. Oil overflow from the bypass valve provides lubrication to the camshaft drive gears.

Normal oil pressure should be 30 psi (207 kPa) or higher when the engine is at normal operating temperature. If pressure drops below this value at governed speed, inspect oil system for faulty components.

Check oil pump thoroughly for worn parts. Oil pump to prime it before reinstalling. Except for gaskets and pick-up cup, component parts of the pump are not available individually. Install a new pump assembly if any parts are worn.

Oil By-Pass Valve

The by-pass valve (located to the right and behind gear cover, Figure 5) controls oil pressure by allowing excess oil to flow directly back to the crankcase. Normally the valve begins to open about 20 psi (138 kPa).

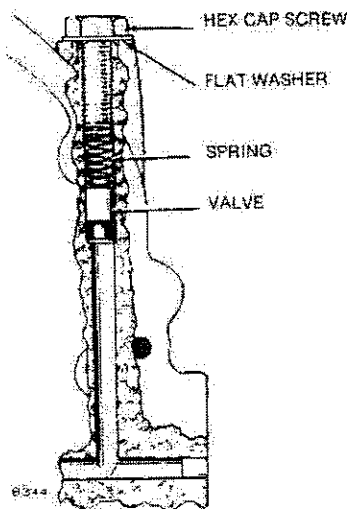

FIGURE 5. BY-PASS VALVE

The valve is non-adjustable and normally does not need maintenance. Determine if valve is operating normally by inspecting plunger action as follows:

1. Remove the 3/8 x 24 x 7/8 cap screw located behind gear cover and under governor arm.
2. Remove spring and plunger with a magnet tool.
3. Determine proper valve operation by checking the spring and plunger according to the following measurements.

Plunger Diameter..... 0.3105 to 0.3125 in.
(7.89 to 7.94 mm)

Spring
Free Length..... 1.00 inch (25.4 mm)
Load: 2.6±0.2 lbs. (11.6±0.9 N)
when compressed to 0.5 inch (12.7 mm)

4. Check the valve seat and clean away any accumulation of metal particles which could cause erratic valve action. Verify that the valve seat is not damaged.
5. Clean plunger and spring in parts cleaning solvent and install.

Fuel System

CARBURETOR

The carburetor mixture screw settings were set for maximum efficiency at the factory and should normally not be disturbed. If adjustments seem necessary, first be sure the ignition system is working properly and governor sensitivity is properly adjusted.

If adjustment is needed, refer to Figures 1 and 2 and proceed as follows:

CAUTION Forcing the mixture adjustment screw tight will damage the needle and seat. Turn in only until light tension can be felt.

1. Walbro mixture screw settings:

Turn both mixture screws in until lightly seated (Figure 1), then back the idle mixture screw out 1/2 turn and the main mixture screw out 1-3/4 turns.

Nikki limited idle adjustment mixture screw settings:

The carburetor has a limited idle adjustment range between stops of $\pm 1/8$ turn. The screw should only be adjusted within these limits; in to lean the mixture, out to richen. There is no main mixture adjustment.

When replacing the idle mixture screw, turn in until lightly seated, then back screw out 1-1/2 turns. Replace limiter cap so the tab is approximately centered.

2. Start the engine and allow it to warm up thoroughly (at least 10 minutes).

Some equipment manufacturers may require higher throttle stop speed and governor low speed rpm settings. Refer to equipment manufacturer's Operator's Manual for the correct rpm settings. When rpm settings are not specified by the equipment manufacturer use the rpm settings listed in Steps 3 and 5.

3. Move the engine speed control to the slow position. Back out the low speed screw on the governor so the throttle stop screw on the carburetor controls engine speed (Figure 2). Adjust the throttle stop screw for 1000 rpm idle.

4. Determine the best idle mixture setting by first turning the idle adjustment screw in until engine speed drops and then outward until engine speed drops again. Over a narrow range between these two settings, engine speed remains at its highest.

Set the adjustment screw about 1/8 turn outward (rich) from the midpoint of this range. On Nikki carburetors the idle adjustment is limited to $\pm 1/8$ turn. Do not go beyond these limits.

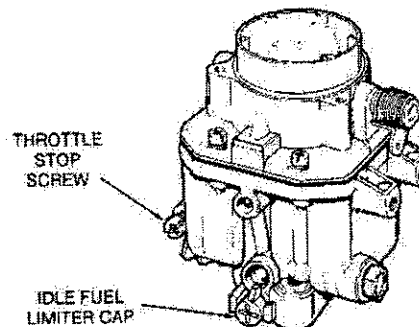

FS-1406-2

NIKKI CARBURETOR WITH SEMI-AUTOMATIC CHOKE AND LIMITED IDLE MIXTURE SCREW.

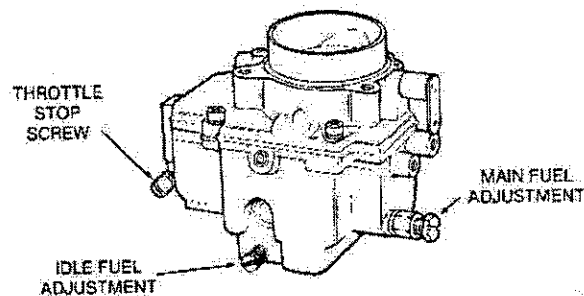

FS-1042

WALBRO CARBURETOR

FIGURE 1. CARBURETOR ADJUSTMENT

5. Readjust the throttle screw for 1000 rpm idle, then adjust the governor low speed screw for 1100 rpm idle.
6. Move the engine speed control to the fast position. Bend the high speed stop on the governor so the engine runs at the vehicle manufacturer's recommended speed (Figure 2.)
7. Check the main mixture adjustment (Walbro carburetors only) by rapidly accelerating the engine from idle to full speed. The engine should accelerate evenly and without hesitation. If it does not, turn the main adjustment screw out in 1/8 turn increments until the engine accelerates smoothly, but do not turn it out more than 1/2 turn beyond the original setting.

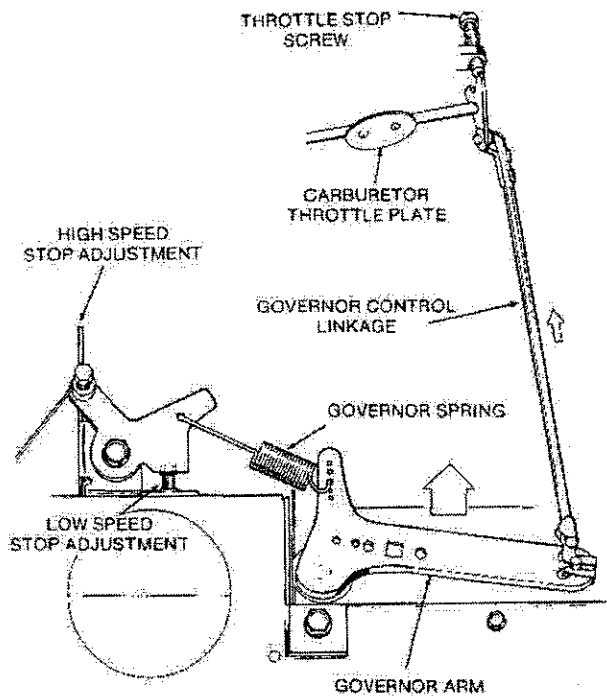

FS-1119

FRONT PULL GOVERNOR

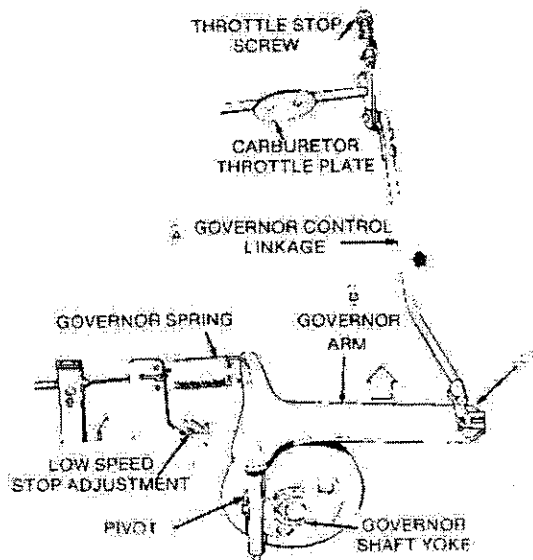

SIDE PULL GOVERNOR

FIGURE 2. GOVERNOR SPEED ADJUSTMENT

CARBURETOR OVERHAUL

Carburetion problems that are not corrected by mixture adjustments are usually a result of gummed-up fuel passages or worn internal parts. The most effective solution is a carburetor overhaul.

In general, overhauling a carburetor consists of disassembly, a thorough cleaning, and replacement of worn parts. Carburetor repair parts are available.

General instructions for overhauling a carburetor are given below. Carefully note the position of all parts while removing to assure correct placement when reassembling. Read through all the instructions before beginning for a better understanding of the procedures involved. Carburetor components are shown in Figure 3.

WARNING Ignition of fuel can cause serious personal injury or death by fire or explosion. Do not permit any flame, cigarette, or other igniter near the fuel system.

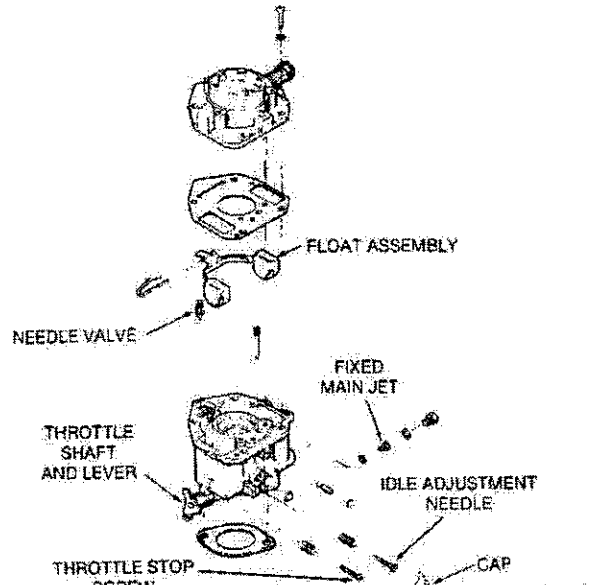

FS-1440-3

NIKKI CARBURETOR

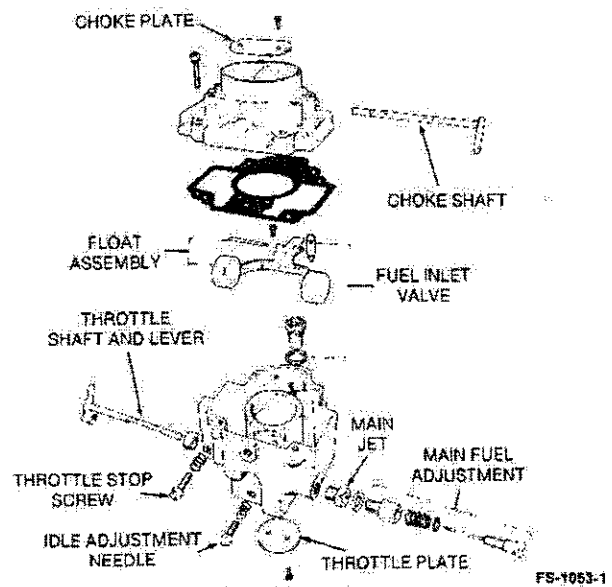

FS-1053-1

WALBRO CARBURETOR

FIGURE 3. CARBURETOR ASSEMBLY

Removal

1. Remove air cleaner and hose.
2. Disconnect governor and throttle linkage, choke control and fuel line from carburetor.
3. Remove the four intake manifold cap screws and lift complete manifold assembly from engine.
4. Remove carburetor from intake manifold.

Disassembly (Walbro)

1. Remove throttle and choke plate retaining screws, then plates. Pull out throttle and choke shafts.
2. Remove main jet and idle adjustment needle.
3. Remove attaching screws and separate upper and lower carburetor sections.
4. Carefully note position of float assembly parts, then pull out retaining pin and float assembly.
5. Remove needle and unscrew needle valve seat.

Disassembly (Nikki limited idle adjustment)

1. Remove main jet and idle adjustment needle.
2. Remove attaching screws and separate upper and lower carburetor sections.
3. Carefully note position of float assembly parts, then pull out retaining pin and float assembly.
4. Remove needle valve.

Cleaning and Repair

1. Soak all metal components not replaced in carburetor cleaner. Do not soak non-metal floats or other non-metal parts. Follow the cleaning manufacturer's recommendations.
2. Clean all carbon from the carburetor bore, especially where the throttle and choke plates seat. Be careful not to plug the idle or main fuel ports.
3. Dry out all passages with low pressure air (35 PSI). Avoid using wire or other objects for cleaning which may increase the size of critical passages.
4. Check the condition of the adjustment needle; replace if damaged. Replace float if loaded with fuel or damaged.
5. Check the choke and throttle shafts for excessive play in their bore. This condition may necessitate replacement of the carburetor.
6. Replace old components with new parts.

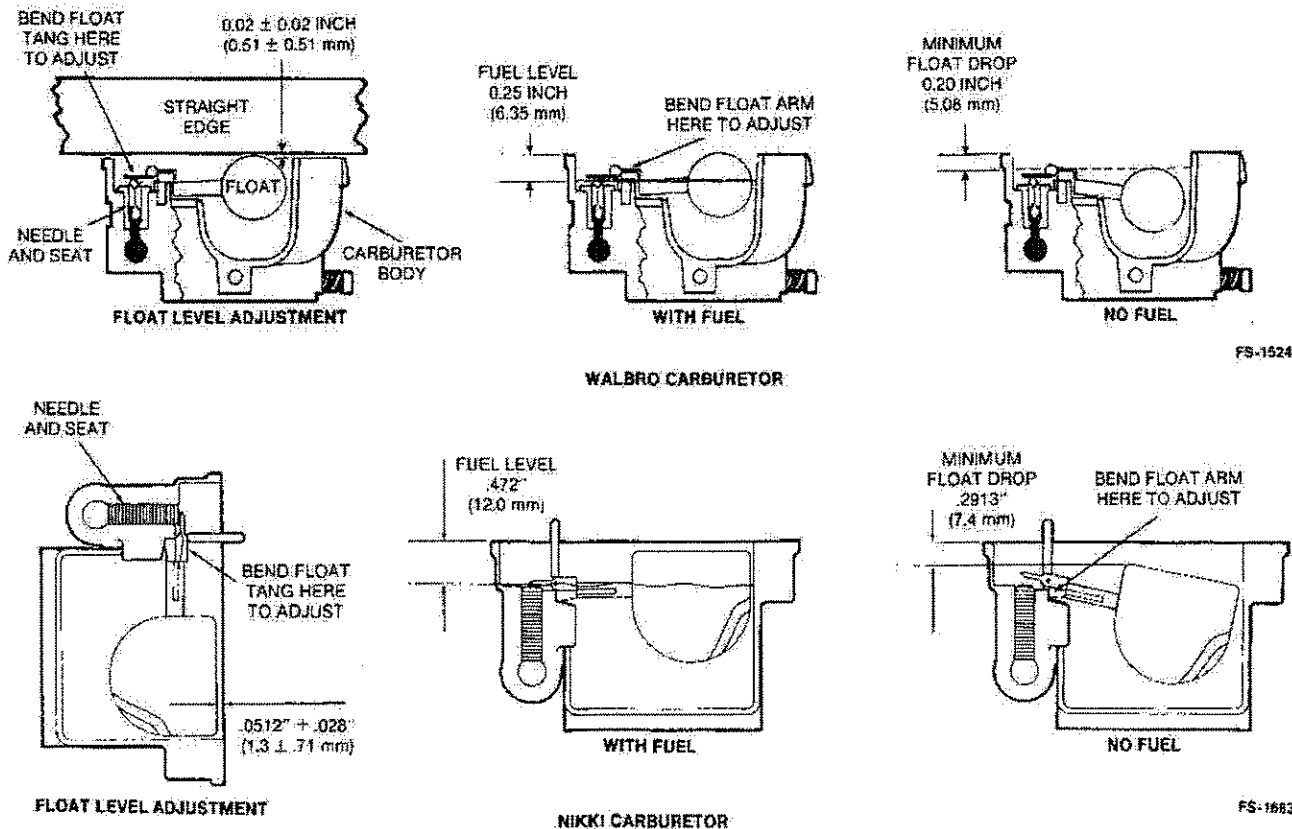

FIGURE 4. CARBURETOR FLOAT LEVEL ADJUSTMENTS

Reassembly and Installation (Walbro)

1. Install needle valve and seat, main jet and float assembly. Make sure that float pivot pin is properly placed and that float moves freely without binding.
2. Gently push float tang down until needle just seats. (Figure 4). Measure float level; adjust if necessary. Release float tang and measure float drop; adjust if necessary. When checking float level and drop, measure to float body, not seam.
3. Position gasket on carburetor and attach carburetor sections together with screws.
4. Slide in throttle shaft and install plate using new screws. Before tightening the screws, the plate must be centered in the bore. To do so, back off the throttle stop screw as necessary and completely close the throttle lever. Seat the plate by tapping with a small screwdriver, then tighten screws. Install the choke shaft and plate in the same manner.
5. Install idle adjustment screw, throttle stop screw, and main fuel adjustment needle.
6. Mount carburetor on intake manifold and install assembly on engine.
7. Mount air cleaner assembly. Connect air intake hose, breather hose, fuel line, vacuum line, and throttle linkage.
8. Adjust carburetor and governor according to directions given in this section.

Reassembly and Installation (Nikki limited idle adjustment)

1. Install needle valve, main jet, and float assembly. Make sure float pivot pin is properly placed and float moves freely without binding.
2. Turn carburetor on its side and measure float level (Figure 4). Adjust float level only if necessary. Measure float drop (the distance from the top of carburetor body to top of float). Adjust only if necessary.
3. Position gasket on lower carburetor section and install upper carburetor section.
4. Install idle adjustment screw, throttle stop screw, and fixed main jet plug.
5. Mount carburetor on intake manifold and install assembly on engine.
6. Mount air cleaner assembly. Connect air intake hose, breather hose, fuel line, vacuum line, and throttle linkage.
7. Adjust carburetor and governor according to directions given in this section.

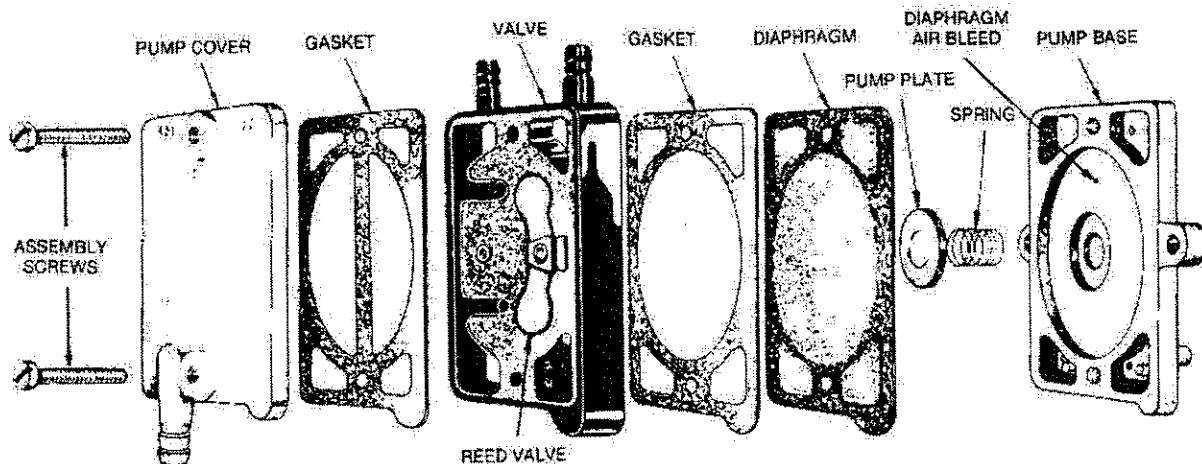

FIGURE 5. EXPLODED VIEW OF FACET FUEL PUMP

PULSATING-DIAPHRAGM FUEL PUMP

Pulsating-diaphragm fuel pumps, or pulse pumps, rely on changes in crankcase vacuum to create a pulsating movement of the pump diaphragm. As the engine's pistons move outward, a vacuum is created. This vacuum is transmitted to the pump diaphragm, causing it to pull back and suck fuel into the pump. As the engine's pistons move inward, crankcase vacuum is reduced and the diaphragm return spring pushes the pump diaphragm forward, forcing fuel through the pump outlet.

Fuel Pump Test Procedure

Before testing make certain that fuel pump vacuum line connections are tight and free of leaks.

1. Operate engine at an idle for five minutes to ensure that carburetor is full of fuel.
2. Shut engine off and remove fuel inlet line from fuel pump.

⚠ WARNING

Spilled fuel can ignite and cause serious personal injury or death. Thoroughly clean-up any spilled fuel.

3. Connect a vacuum gauge to fuel pump inlet using a piece of fuel hose with clamps.
4. Start engine and allow to idle for at least five seconds. Record vacuum gauge reading.
5. Move throttle control to high idle position. Wait at least five seconds and record vacuum gauge reading.
6. Shut engine off and remove vacuum gauge hose from fuel pump inlet. Connect fuel inlet line to fuel pump.
7. Remove fuel outlet line from fuel pump.

▲WARNING *Spilled fuel can ignite and cause serious personal injury or death. Thoroughly clean-up any spilled fuel.*

8. Connect a pressure gauge to fuel pump outlet using a piece of fuel hose with clamps.
9. Start engine and allow to idle for at least five seconds. While holding pressure gauge level with pump outlet, record pressure gauge reading.
10. Move throttle control to high idle position and allow engine to run for at least five seconds. While holding pressure gauge level with pump outlet, record pressure gauge reading.
11. Shut engine off and remove pressure gauge hose from fuel pump outlet. Connect fuel outlet line to fuel pump.

Repair or replace the fuel pump if test readings are not within the values specified in TABLE 1.

**TABLE 1
PULSE PUMP TEST SPECIFICATIONS**

Engine Speed	Pump Inlet Vacuum (Minimum)	Pump Outlet Pressure (Minimum)
Low Idle	2.6 inches of mercury	1.7 psi
High Idle	2.6 inches of mercury	1.7 psi

Fuel Pump Repair

This section applies only to Facet fuel pump. The Nikki fuel pump is not repairable; replace unit if test readings are not within the values specified in TABLE 1.

1. Remove the vacuum and fuel lines. Inspect the lines for wear, cracking or brittleness. Replace as necessary.
2. To insure correct alignment when reassembling, scribe a line across the outer pump parts on each end of the pump.
3. Holding the pump carefully, remove the assembly screws (Figure 5).
4. Carefully pull apart the pump sections and check for worn or damaged parts. Replace with new parts where necessary or install pump repair kit.
5. Check and unclog if necessary the small diaphragm air bleed hole located behind the pump diaphragm in the pump base.

▲CAUTION *A clogged diaphragm air bleed hole can cause diaphragm wear and seal damage while inhibiting pump operation.*

6. Replace gaskets and reassemble pump. Reinstall assembly screws, checking the scribe marks for proper alignment. Reinstall fuel and vacuum lines and clamps.

▲WARNING *Use care when reassembling and reinstalling the pump. Improper parts alignment or misconnected fuel lines can result in leaking fuel, creating a serious fire hazard.*

AIR CLEANER

▲CAUTION *If air cleaner becomes too dirty, engine will not receive sufficient air to run properly. Symptoms: Loss of power, flooding, hard starting and overheating.*

Engine is equipped with a paper element. If the engine is equipped with polyurethane precleaner, it must be removed, cleaned and oiled every 25 hours of operation, or more under extremely dusty conditions.

1. To clean precleaner, wash in water and detergent (Figure 6). Remove excess water by squeezing like a sponge and allow to dry thoroughly. Distribute two tablespoons of SAE 30 engine oil evenly around the precleaner. Knead into and wring excess oil from precleaner.

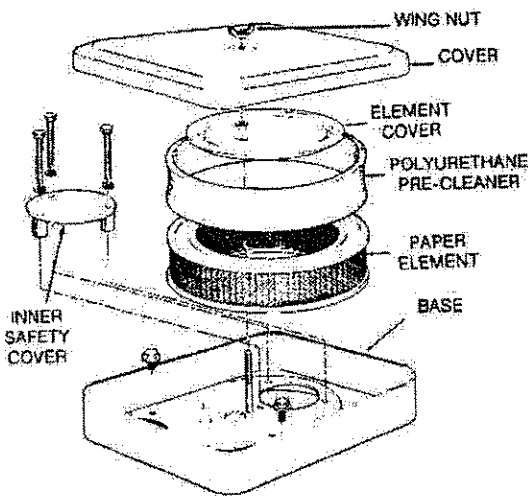

1. WASH
2. SQUEEZE DRY
3. COAT WITH OIL
4. INSTALL OVER PAPER ELEMENT

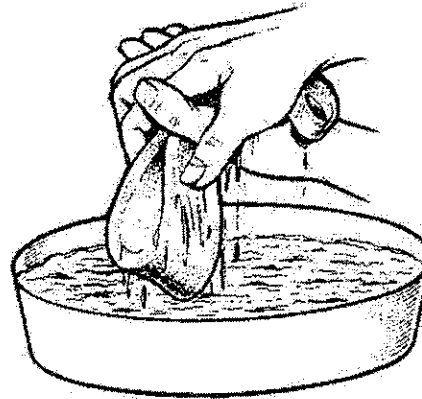

FS-1131

FIGURE 7. AIR CLEANER ASSEMBLY

2. Depending on conditions in which the engine is operating, the inner paper element should be replaced whenever it becomes excessively dirty or oily.

CAUTION *Never run engine with air cleaner removed. Dirt will enter engine and wear out rings causing excessive blow-by.*

DASHPOT ADJUSTMENT

On engines equipped with a dashpot, adjust as follows:

1. Pull governor arm and linkage (away from carburetor) until throttle stop contacts throttle stop screw.

2. Holding throttle against throttle stop screw, adjust dashpot to obtain 0.050 inch (1.27 mm) clearance (Figure 8).

3. Secure dashpot to air cleaner support bracket with hex nut.

CAUTION *Do not grip dashpot with a pliers; internal damage may occur. If necessary hold dashpot by hand when tightening hex nut.*

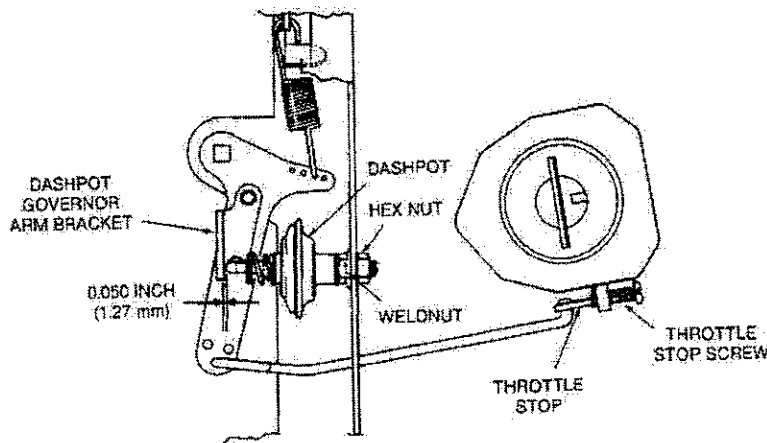

FIGURE 8. DASHPOT CLEARANCE

FS-1656

GOVERNOR ADJUSTMENT

These engines are adapted for use where a wide range of speed settings is desired. Engine speed is controlled at any given point between minimum and maximum by simply shifting the throttle lever on the dash panel until the desired speed is reached.

A reliable instrument for checking engine speed is required for accurate governor adjustment. Engine speed can be checked with a tachometer.

Check the governor arm, linkage, throttle shaft, and lever for a binding condition or excessive slack and wear at connecting points. A binding condition at any point will cause the governor to act slowly and regulation will be poor. Excessive looseness may cause a hunting condition and regulation could be erratic. Work the arm back and forth several times by hand while the engine is stopped to check for above conditions.

If the governor is hunting or not operating properly, adjust as follows (Figure 9).

1. Disconnect linkage (A) from one of holes (C).
2. Push linkage (A) and governor arm (B) as far back (toward carburetor) as they will go.
3. Holding linkage and governor arm toward direction of carburetor, insert end of linkage into whichever hole (C) in governor arm lines up the closest. If between two holes, insert in next hole out. Install clip to secure rod to arm.

On side pull governor the governor spring is set by the factory in the third hole of the governor arm. (Third hole from pivot). On front pull governors the governor spring is set by the factory in the second hole of the governor arm adapter. (Second hole from pivot.) To increase sensitivity, move spring loop into a hole closer to the pivot. To decrease sensitivity, move spring loop into a hole farther away from the pivot. After sensitivity has been set, recheck the low speed rpm setting. Adjust if necessary.

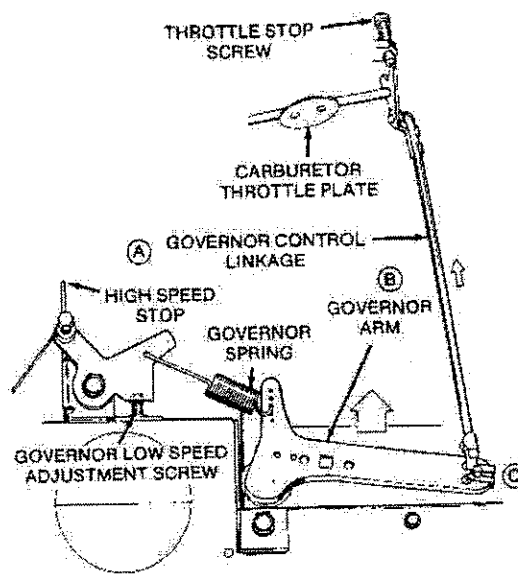

FRONT PULL GOVERNOR

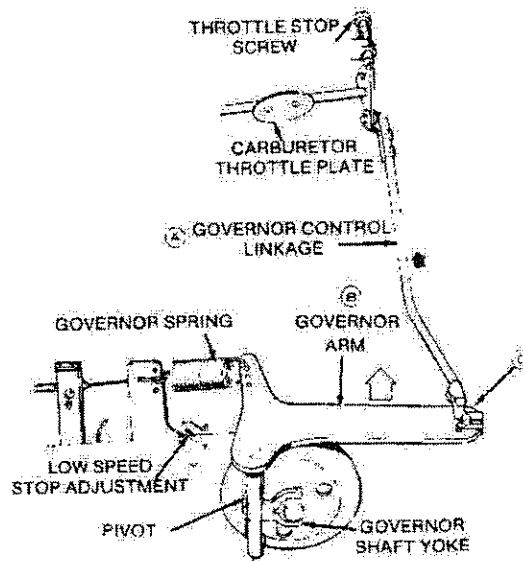

SIDE PULL GOVERNOR

FIGURE 9. VARIABLE SPEED GOVERNOR ADJUSTMENTS

Ignition and Battery Charging

BREAKER POINT IGNITION SYSTEM

This section applies to those engines equipped with an automotive type battery ignition system. Both spark plugs fire simultaneously, thus the need for a distributor is eliminated. To maintain maximum engine efficiency, change the breaker points every 200 hours of operation.

IGNITION TIMING

The timing is preset at the factory. Slight timing changes can be made by adjusting the point gap.

Breaker Point Replacement and Adjustment

1. Remove spark plugs.
2. Remove breaker box cover. Rotate crankshaft clockwise (facing flywheel) until points are fully open.
3. Remove condenser (screw A) and detach condenser lead and coil lead (screw B). See Figure 1.
4. Remove two Allen screws (C) and lift breaker assembly from engine.
5. Replace condenser and point assembly with new parts and reinstall using above procedure in reverse order of removal.
6. Adjust point gap by rotating crankshaft clockwise (facing flywheel) by hand until the points are fully open. Set the point gap (using flat feeler gauge) at 0.020 inch (0.51 mm) by adjusting the socket head screw (D) inward or outward (Figure 1). A 0.020 inch point gap is equivalent to 20° BTC. Make sure feeler gauge is clean and free of any grease, oil or dirt.

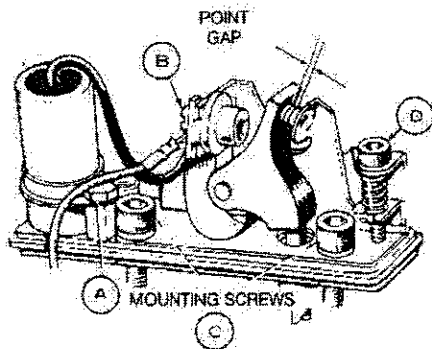

FIGURE 1. SETTING POINT GAP

7. Replace breaker box cover, coil wire, spark plugs, and spark plug cables.

Continuity Test

As a check for proper ignition timing a continuity test may be performed:

1. Adjust breaker points.
2. Remove blower housing to expose timing marks on top of gearcase cover and flywheel (Figure 2).

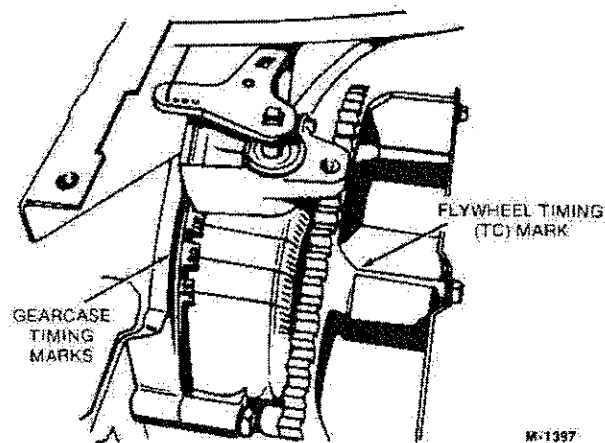

FIGURE 2. TIMING MARKS

3. Rotate flywheel clockwise until timing mark is aligned with the proper timing mark (Figure 2) located on top of gearcase cover. Refer to *SPECIFICATIONS* for proper number of timing degrees.
4. Connect an ohmmeter or a continuity test lamp set across the ignition breaker points. Touch one test prod to the coil lead terminal (screw B, Figure 1).
5. Touch the other test prod to a good ground on the engine.
6. Turn crankshaft against rotation (counterclockwise) until the points close. Then slowly turn the crankshaft with rotation (clockwise).
7. The lamp should go out or continuity lost just as the points break which is where ignition occurs. If timing is early (advanced) the point gap is too large. If timing is late (retarded) the point gap is too small. Adjust point gap accordingly.

ELECTRONIC IGNITION SYSTEM

This section applies to those engines equipped with an electronic battery ignition system. Both spark plugs fire simultaneously, thus the need for a distributor is eliminated. The electronic ignition module is located on the engine gear cover behind the flywheel. The module receives a timing signal from the magnets located within a trigger ring which rotates on the engine crankshaft (Figure 3). If the electronic ignition is suspected of malfunctioning, proceed as follows:

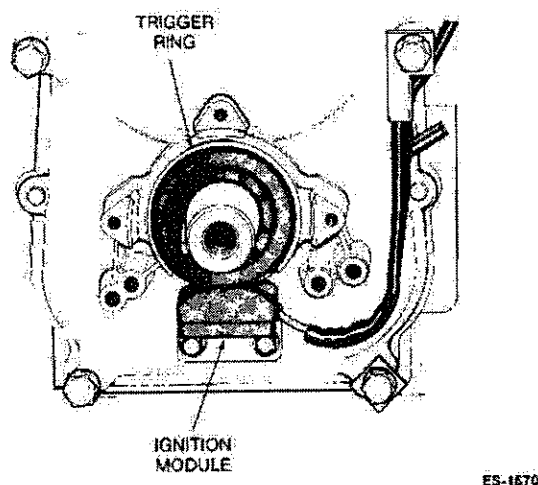

FIGURE 3. IGNITION MODULE AND TRIGGER RING

1. Check all electrical connections to be sure they are clean and tight. If all connections are good and wiring is intact, go to step 2.

▲WARNING *The electronic ignition will deliver full voltage to the spark plugs even when rotated by hand. Care should be taken to avoid an electrical shock.*

▲WARNING *Failure to remove spark plugs before turning engine over may result in engine starting, which may cause severe personal injury.*

▲WARNING *Failure to ground spark tester away from spark plug hole may result in ignition of cylinder gases and may cause severe personal injury.*

2. Pull spark plug wires off spark plugs and remove spark plugs. Connect an approved spark tester to each of the spark plug wires and ground them away from spark plug hole. Turn key on and crank engine over for 5 seconds while watching for spark. If a spark occurs regularly, the problem is not in the ignition system. If no spark occurs, go to step 3.

▲CAUTION *Never put jumper lead to the coil negative terminal. This will cause failure of the electronic ignition module.*

3. Connect a jumper lead directly from the positive battery terminal to the positive (+) coil terminal (smaller diameter of the two threaded posts). Crank engine over while watching for spark. If spark occurs, the problem is in the low oil pressure cut out switch or related wiring, the lubricating system (low oil pressure), or in the other circuitry bringing voltage to the coil. If no spark occurs, go to step 4.
4. Refer to IGNITION COIL section to test coil for proper resistance. If coil checks out good, go to step 5.
5. Connect positive side of voltmeter to negative (-) coil terminal (larger diameter of the two threaded posts) and negative side of voltmeter to engine ground. Turn key on and rotate flywheel slowly by hand while observing voltmeter. Voltage should switch back and forth between battery voltage and 1-1.5. If voltage does not switch properly, replace ignition module.
6. Install spark plugs and wires. If ignition module is being replaced, be sure to connect red lead from new ignition module to positive (+) terminal of coil, black lead from module to negative (-) terminal of coil.

▲CAUTION *Never put B+ lead to the coil negative terminal. This will cause failure of the electronic ignition module.*

IGNITION TIMING

The ignition timing is preset at the factory and is not adjustable. For troubleshooting purposes, it is possible to make an approximate check of the ignition timing by removing blower housing and using the gearcase timing marks.

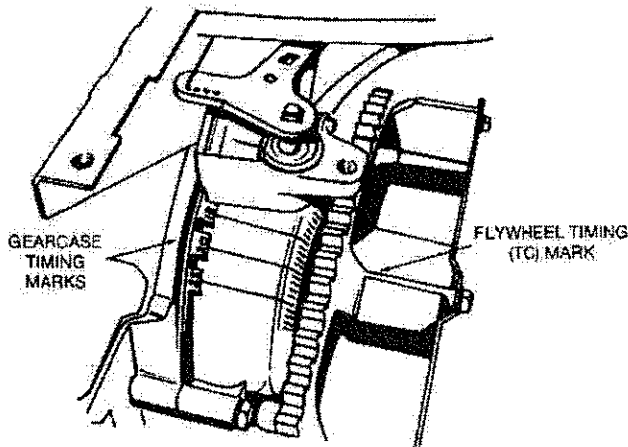

FIGURE 4. IGNITION TIMING MARKS

Continuity Test

1. Pull spark plug wires off spark plugs and remove spark plugs and blower housing.

CAUTION Failure to remove spark plugs before turning engine over may result in engine starting, which may cause severe personal injury.

2. Turn ignition on.
3. Connect a voltmeter between the negative (-) coil terminal (larger diameter of the two threaded posts) and a good engine ground.

WARNING The electronic ignition will deliver full voltage to the spark plugs even when rotated by hand. Care should be taken to avoid an electrical shock from the spark plugs.

4. Rotate the flywheel slowly by hand in the clockwise direction until the voltmeter reading jumps from approximately 1 volt to battery voltage. At this point the flywheel timing mark should line up with the proper timing degree (see *SPECIFICATIONS*) mark located on the gearcase timing marks. To recheck timing, the flywheel must be rotated another complete revolution in the clockwise direction. Moving the flywheel back and forth across the timing marks will not activate the electronic ignition control.
5. Install spark plugs, wires, and blower housing.

BREAKER POINT AND ELECTRONIC IGNITION COILS

To test primary and secondary windings within the ignition coil first make sure the ignition power is off and coil is at room temperature of 70°F (21°C).

1. Use a Simpson 250 VOM or equivalent.
2. Place a black lead on the negative (-) coil terminal and a red lead on the positive (+) coil terminal. Primary resistance should read between 3.87-4.73 ohms for breaker point coils, and between 2.90-3.60 for electronic ignition coils.
3. Change resistance setting on ohmmeter. Place ohmmeter leads inside on spark plug cable holes (Figure 5). Secondary resistance should read between 12,600-15,400 ohms for breaker point ignition coils, and between 14,500-19,800 ohms for electronic ignition coils.
4. If any of the above conditions are not met, replace coil.

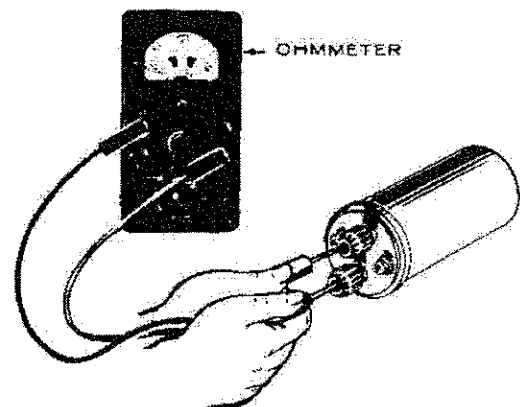

FIGURE 5. COIL TEST

SPARK PLUGS

Check and regap spark plugs every 100 hours of operation (Figure 6). Replace spark plugs that show signs of fouling or electrode erosion.

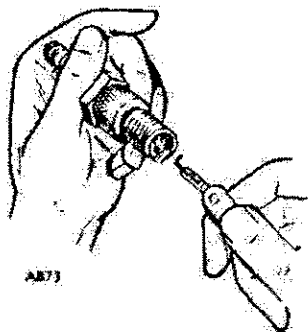

FIGURE 6. SPARK PLUG GAP

BATTERY INSPECTION

Check battery cells with a hydrometer. (Figure 7). The specific gravity reading should be approximately 1.260 at 77°F (25°C).

If one or more cells are low on water, add distilled water and recharge. Keep the battery case clean and dry. An accumulation of moisture will lead to a more rapid discharge and battery failure.

Keep the battery terminals clean and tight. Push the cable terminal down flush with or slightly below the top of the battery post (Figure 8). After making connections, coat the terminals with a light application of petroleum jelly or grease to retard corrosion.

Poor contact at the battery cable connections is often a source of trouble. Make sure battery cables are in good condition and that contacting surfaces are clean and tightly connected. Do not reverse battery leads. Use recommended battery tools when disconnecting leads to avoid mechanical battery damage.

WARNING Ignition of explosive battery gases can cause severe personal injury. Do not smoke while servicing batteries.

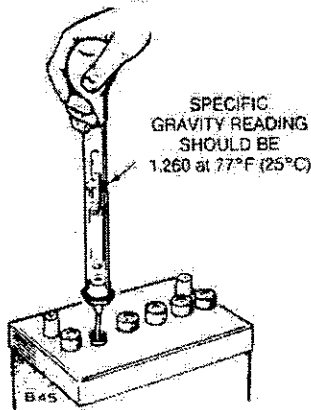

FIGURE 7. SPECIFIC GRAVITY TEST

BATTERY JUMP STARTING

Occasionally, it may be necessary to jump start (charge) a weak battery using a charged booster battery. If jump starting is necessary, the following procedure is recommended in order to prevent starter damage, battery damage and personal injuries.

CAUTION Do not engage starter for periods longer than 30 seconds without allowing 5 minutes for starter to cool. Starter failure may result if these guidelines are not followed.

1. Disconnect engine load.
2. Use only a battery of the same voltage (12V) as is used with your engine.
3. Attach one end of the positive booster cable (red) to the positive (+) terminal of the booster battery. Attach the other end of the positive cable to the positive (+) terminal of your engine battery.
4. Attach one end of the negative (-) booster cable (black) to negative (-) terminal of booster battery. Attach other end of negative cable to a solid chassis ground on your engine.

WARNING Do not allow the positive and negative cable ends to touch each other because it will short the battery causing hazardous arcing, which can cause severe personal injury.

5. Jump starting in any other manner may result in damage to the battery or the electrical system.
6. Turn ignition switch to ON to start engine.

WARNING Never jump start a frozen battery. To do so can cause the battery to explode. Never expose the battery to an open flame or an electrical spark because a battery generates highly explosive hydrogen gas.

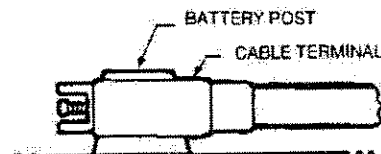

FIGURE 8. BATTERY CABLE CONNECTION

FLYWHEEL ALTERNATOR

This unit is equipped with a permanent magnet flywheel alternator and solid-state voltage regulator-rectifier (output control). See Figure 9. As with all solid-state electrical units, precautions are necessary when servicing. Observe the following:

CAUTION This engine uses a 12 volt, negative ground system. Alternator must be connected to battery at all times when engine is running. Do not reverse battery cables.

Weak ignition spark or a discharged battery indicates trouble in the charging system. But before testing the engine's charging system, always check the battery for serviceability.

Keep these points in mind when testing or servicing the flywheel alternator:

1. Be sure engine is being run long enough and fast enough to recharge battery after each start. Charging system tests require a full charged battery. Alternator output is reduced in direct proportion to engine rpm. Also, power required for accessories reduces power available to recharge battery.

2. The regulator-rectifier has built in protection against open circuits or short circuits on the alternator output (B+) terminal. Either condition will cause the regulator-rectifier to shut off and appear as if it is not functioning. Prior to checking the regulator-rectifier, check all wiring between the regulator-rectifier B+ terminal and the battery positive (+) terminal to assure it is free of open circuits, resistances or short circuits. Also, if the battery is extremely discharged it may have insufficient power to "turn on" the regulator-rectifier.

3. Be sure regulator-rectifier plug (connector) is inserted properly. Plug must bottom in receptacle; this eliminates any resistance due to a poor connection. Keep clean and tight.
4. Make sure alternator stator leads are not shorted together.
5. Be sure regulator-rectifier has a good ground connection. Mating surface for mounting must be clean and fasteners tightened properly.
6. Never reverse the battery leads.

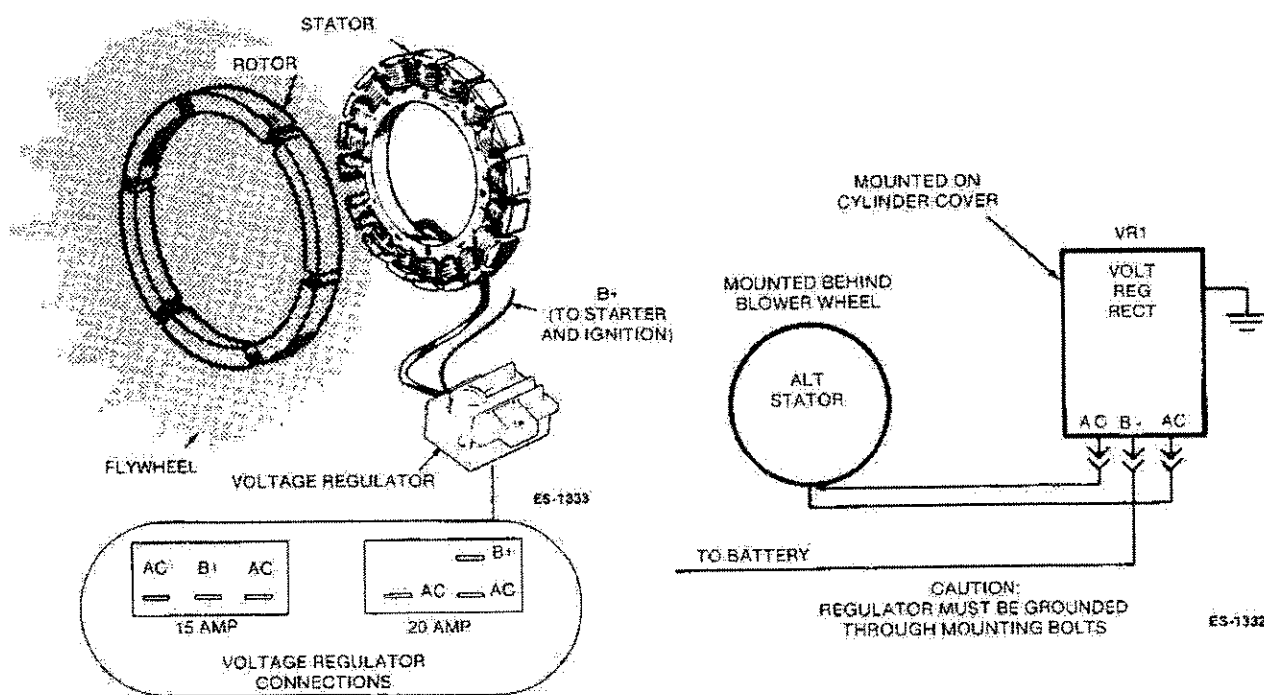

FIGURE 9. FLYWHEEL ALTERNATOR SYSTEM

With the engine running between 1800 to 2600 rpm, observe the panel ammeter (if not already equipped, connect a test ammeter). If no charging is evident, proceed with the *Alternator Output Test*.

ALTERNATOR OUTPUT TEST

Use a volt-ohmmeter such as the Simpson 270, when testing the charging system.

1. With the engine running, check the battery terminal voltage (regulator output) using a DC voltmeter. Voltage output should be within the values specified in Table 1. If voltage is greater than specified replace regulator-rectifier assembly. If voltage is less than specified, proceed to step 2.
2. Examine all wires for loose, corroded, broken connections, short circuits, etc. Check fuses. Repair as needed to assure complete circuits from regulator-rectifier B+ terminal to battery positive (+) terminal

and from battery negative (-) terminal to regulator-rectifier case. If battery voltage remains low with engine running, proceed to step 3.

3. Disconnect plug from regulator-rectifier and test the AC voltage at the plug with engine running near 3600 rpm. If AC voltage reads more or less than specified in Table 1, proceed to step 4. If AC voltage is as specified but DC voltage is low, replace regulator-rectifier.
4. Use the Rx1 scale on the ohmmeter for detecting opens in the stator (unit not running). Disconnect plug from regulator-rectifier. Connect ohmmeter test leads to wires coming from stator. Refer to Table 1 for resistance specifications. If resistance is not as specified, replace stator. If stator resistance readings are as specified and windings are not shorted to ground, low AC voltage may be due to loss of magnetism. If so, blower wheel assembly must be replaced. Check for magnetism with steel tool blade. Next, connect one ohmmeter test lead to stator wire, connect the other test lead to ground. If the ohmmeter reading is low the stator is grounded and must be replaced.

TABLE 1. TESTING 15- AND 20-AMPERE SYSTEMS

BASIC TEST	PROCEDURE	TEST VALUES	
		15A. SYSTEM	20A. SYSTEM
1. Battery	Battery Voltage — unit not running.	12 VDC	12 VDC
2. Regulator	Battery Voltage after unit is running 3 to 5 minutes.	13.6 to 14.7 VDC	13.6 to 14.7 VDC
3. Alternator Stator and Wiring	Ohmmeter reading from stator output — unit not running. Check at plug.	0.1 to 0.2 Ohms	0.3 to 0.5 Ohms
4. Alternator and Wiring	Measure AC open circuit stator voltage with unit running. Measure between two stator leads with plug disconnected and unit running at approximately 3600 rpm.	40 VAC minimum 60 VAC maximum	31 VAC minimum 51 VAC maximum

ENGINE WIRING DIAGRAM (Inertia Type Starter)

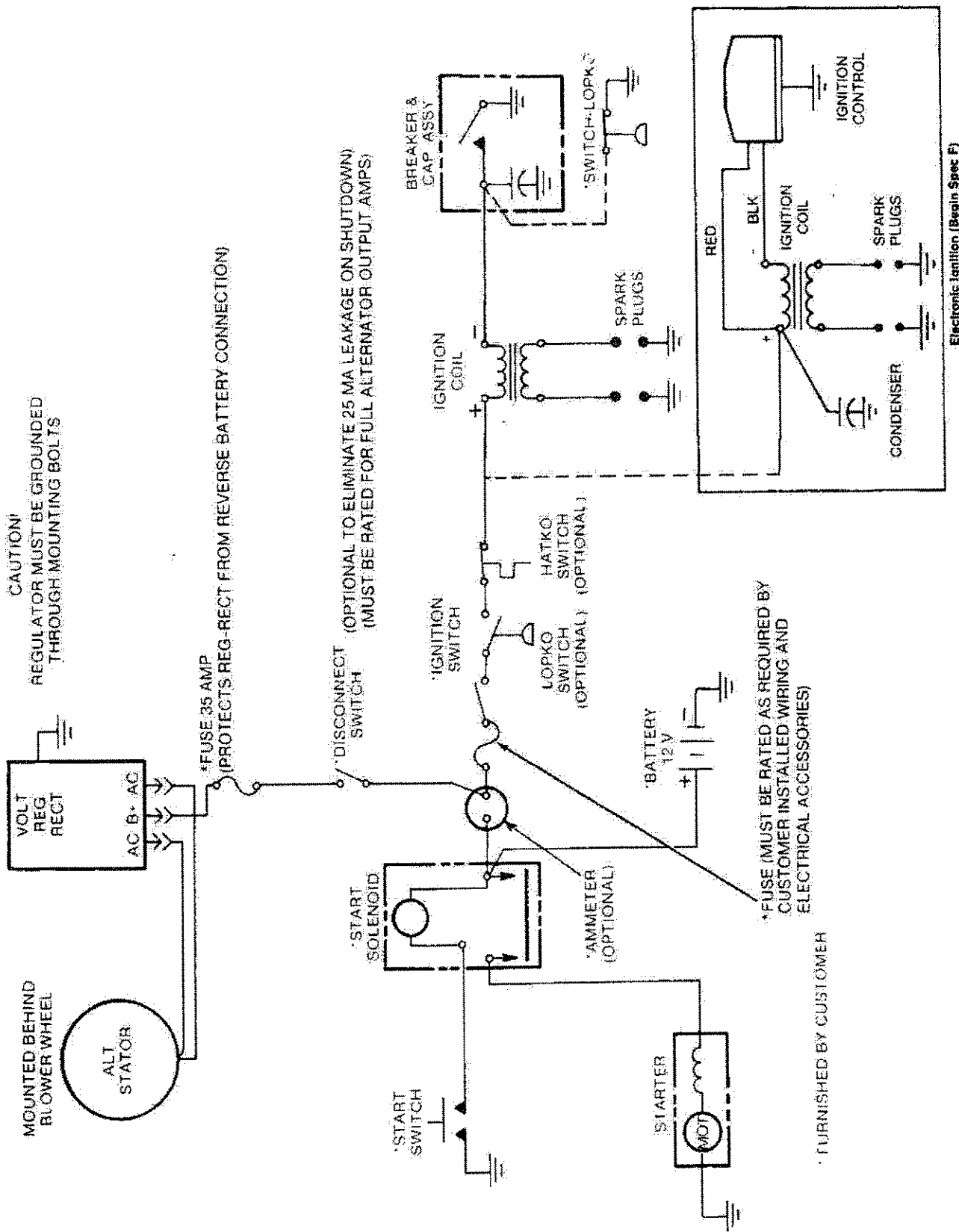

ES-1631-2

ENGINE WIRING DIAGRAM (Solenoid Shift Type Starter)

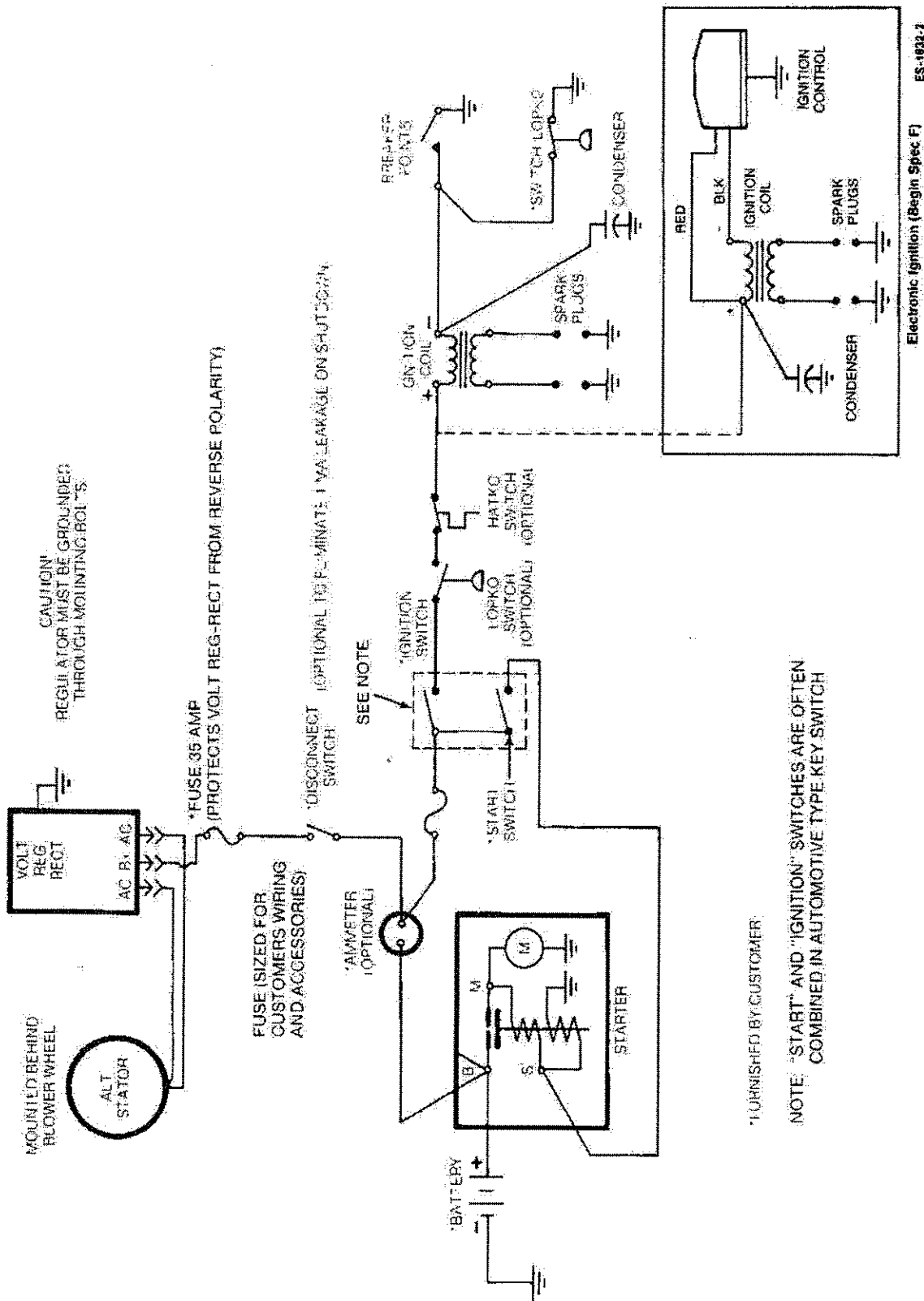

ES-1032-2

NOTE: "START" AND "IGNITION" SWITCHES ARE OFTEN COMBINED IN AUTOMOTIVE TYPE KEY SWITCH

*FURNISHED BY CUSTOMER

Starting System

ELECTRIC STARTER

Normally the starter will require little or no service other than possible brush replacement. However, if through accident or misuse, the starter requires service or overhaul, the following information will provide the information necessary to perform this service.

Service

When starting engine, note starter motor action. The pinion gear should mesh quickly with flywheel ring gear and spin engine. Once engine starts and solenoid opens, the starter should disengage and stop. If starter cranks engine slow, or not at all, check start circuit components. Failure to crank is normally caused by low battery charge, defective battery cables, corroded or poor connections, or low temperatures. If after checking these variables, starter continues to crank slowly, starter must be removed and repaired.

Starter Removal

▲WARNING *Accidental starting of the engine can cause severe personal injury or death. Disconnect the battery cables when repairs are made to the engine, controls, or housings.*

1. Remove both battery cables from battery. Disconnect ground cable first.

2. Disconnect battery cable and electrical lead wires from starter.
3. Remove blower housing and cylinder air housing.
4. Remove flywheel and starter motor.

Starter Disassembly (Inertia Type)

1. Remove through-bolts and separate end cap, housing, and armature (Figure 1).
2. Disassemble drive assembly and drive end cap by loosening the self-locking stop nut.
3. Inspect starter for damaged or worn parts.
4. Repair or replace all damaged or worn parts, as needed.

Starter Assembly (Inertia Type)

1. Before reassembling the starter, wipe off any dirt from parts with a clean cloth or blow off with filtered, compressed air.

▲CAUTION *Do not immerse bearings in cleaning fluid. Use a brush dipped in clean engine oil for dirt removal.*

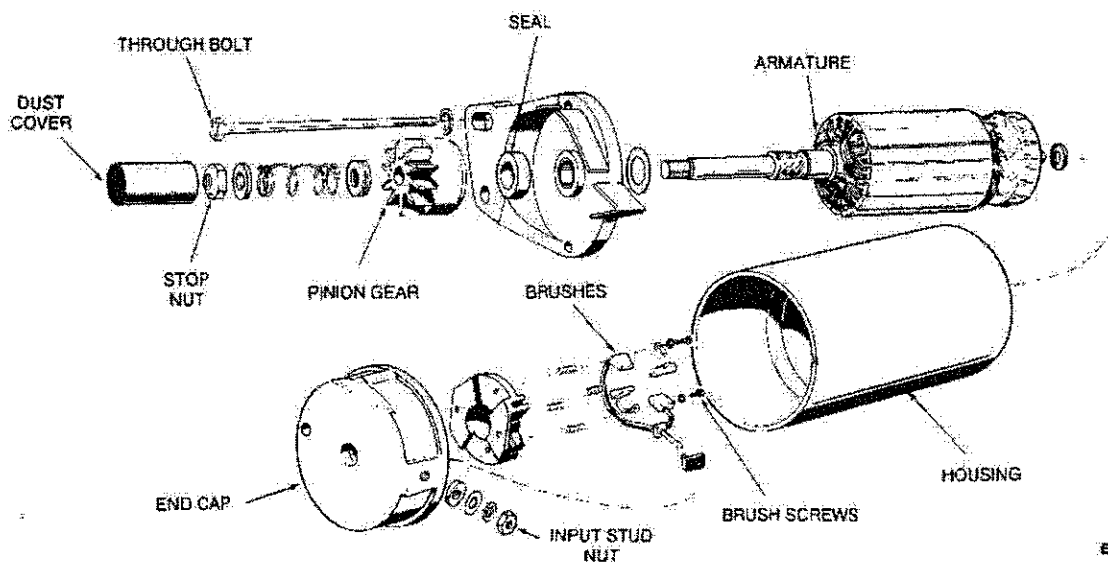

FIGURE 1. STARTER MOTOR (INERTIA TYPE)

ES-1334

2. Assemble brushes so that the chamfered side is away from the brush springs. Make sure brush wires do not rub against the commutator or end cap.
3. Torque brush screws to a value of 3 to 3.5 ft-lbs (4 to 5 Nm).
4. Torque input stud nut to a value of 4 to 5 ft-lbs (5 to 7 Nm).
5. Apply a thin film of grease to the commutator end of the armature shaft and to the portion of the shaft that contacts the bearings. Apply a generous film of silicone base grease (GE Versilube 322-L) to the shaft threads.
6. Torque stop nut to a value of 20 to 25 ft-lbs (27 to 34 Nm).
7. Torque through bolts to a value of 4.5 to 6 ft-lbs (6 to 8 Nm).
8. Apply a small amount of a silicone based grease (GE Versilube 322-L) to armature shaft spline.
9. Install dust cap, pinion gear, dust cover spacer, anti-drift spring, stop nut washer, and stop nut.
10. Push dust cover on until it snaps into position.

Starter Disassembly (Solenoid Shift Type)

1. Remove "M" terminal nut and wire lead from solenoid (Figure 2).
2. Remove the two solenoid mounting screws and remove solenoid.
3. Scribe a mark across frame and rear bracket to aid in assembly. Remove the two through bolts.
4. Remove rear bracket and frame assembly.
5. Carefully remove armature and lever from front bracket. Note direction of lever and retainer.
6. Remove the two brush mounting screws, and remove the rear bracket.
7. Remove brush holder assembly from the frame by pulling the brushes out.

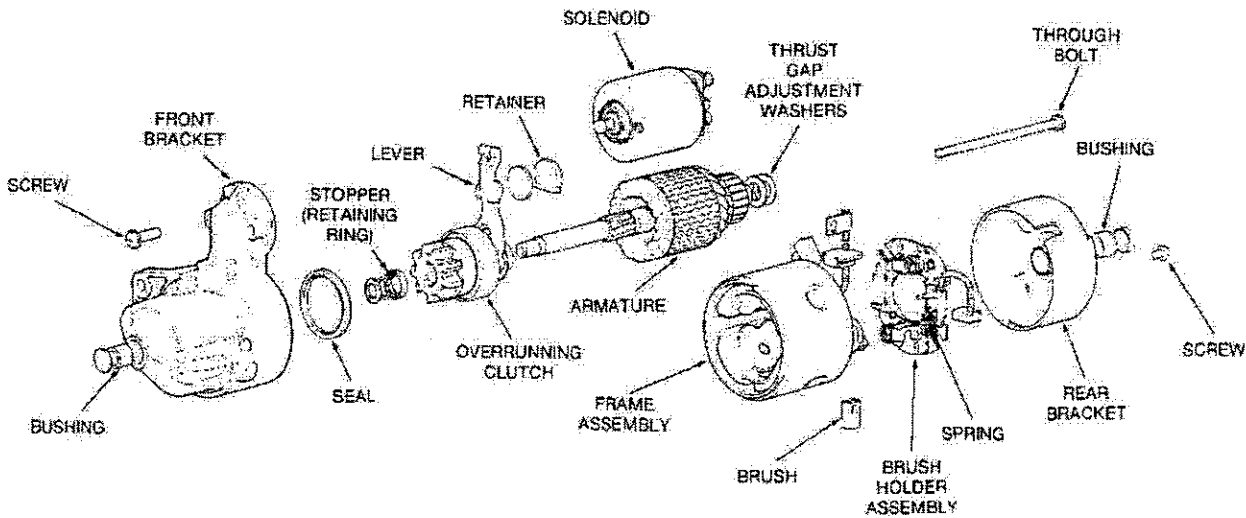

ES-1621

FIGURE 2. STARTER MOTOR (SOLENOID SHIFT TYPE)

8. Push stopper toward pinion and remove snap ring (Figure 3).

9. Remove stopper and overrunning clutch from armature shaft.

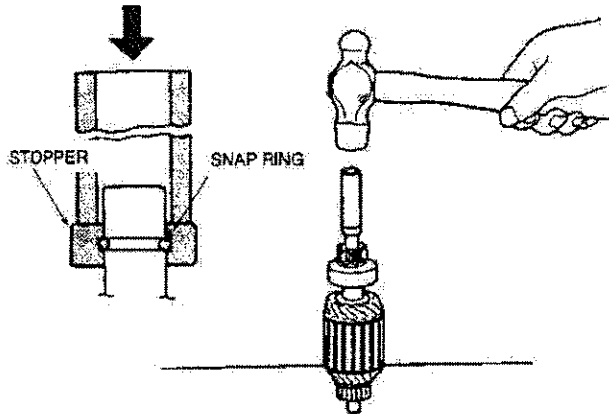

ES-1622

FIGURE 3. REMOVING OVERRUNNING CLUTCH

10. Inspect starter for damaged or worn parts.
11. Repair or replace all damaged or worn parts, as needed.

Starter Assembly (Solenoid Shift Type)

1. Install seal in nose housing. Install overrunning clutch on the armature shaft.
2. Slide stopper on the armature shaft. Position snap ring in groove in armature shaft.
3. Pull stopper all the way over snap ring (Figure 4). It may be necessary to tap snap ring into groove with a punch while maintaining tension on stopper.

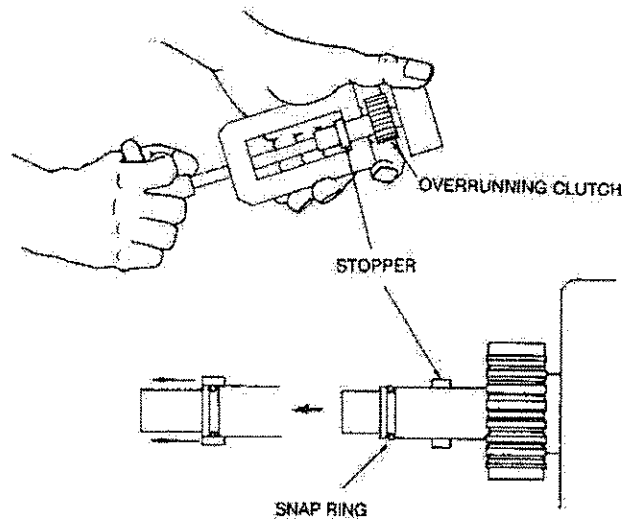

ES-1194

FIGURE 4. INSTALLING STOPPER

4. Lubrication: When starter motor is assembled apply grease to each of the following points (Recommended grade: Multemp PS No. 2):

- Armature shaft spline
- Both bushings (Both ends of armature)
- Stopper on armature shaft
- Pinion gear
- Sliding portion of lever

5. Fit overrunning clutch into lever, and install with armature in the front bracket.

6. Install lever retainer and spacer. Position frame assembly over armature on the front bracket.

7. Install brush holder assembly. Position brushes in brush holder. Make certain positive lead wires are not grounded.

8. Install washers, as required, on the rear end of armature shaft to obtain an armature shaft thrust gap of 0.05 to 0.5 mm (0.002 to 0.02 inch). New washers are required if rear bracket is replaced.

Table 1. Starter Assembly Torques

Solenoid Screws	6 Nm	(54 in.-lb.)
Brush Retaining Screws	4 Nm	(33 in.-lb.)
Through Bolts	5.7 Nm	(51 in.-lb.)

9. Install rear bracket. Secure brush holder to rear bracket with two machine screws.

10. Install and tighten the two through capscrews.
11. Install solenoid plunger in lever. Secure solenoid to front bracket with two machine screws.
12. Install wire lead to the terminal "M" on solenoid.
13. After assembly, adjust pinion clearance. Pinion clearance should be 0.020 to 0.080 inch (0.5 to 2.0 mm); if not, check as follows. See Figure 5.

- A. Connect starter to a battery, as shown in Figure 5. Close switch. This will shift pinion into cranking position.
- B. Push pinion back by hand and measure pinion clearance. If clearance does not fall within the specified limits, adjust by adding or removing shims located between solenoid and front bracket. Adding shims decreases clearance; removing shims increases clearance. Shims are included with replacement solenoid.

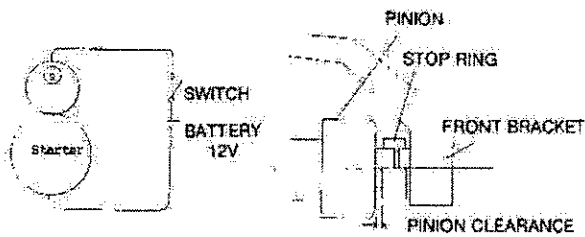

ES-1923

FIGURE 5. PINION CLEARANCE ADJUSTMENT

Inspection and Testing

Inspect the starter components for mechanical defects before testing for grounds or shorts.

Testing Armature for Grounds: Touch armature shaft or core and the end of each commutator bar with a pair of ohmmeter leads (Figure 6). A low ohmmeter reading indicates a grounded armature. Replace grounded armature.

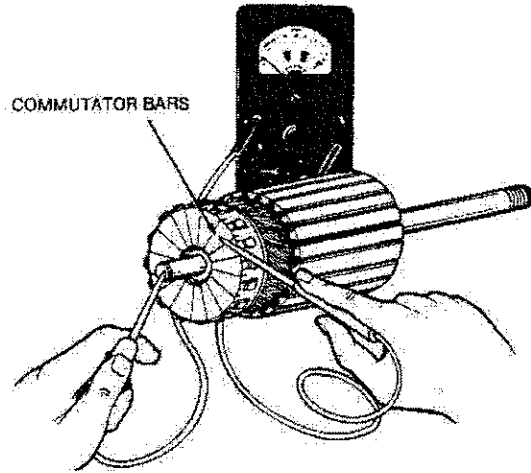

ES-1901

FIGURE 6. TESTING ARMATURE FOR GROUNDS

Inspecting for an Open Circuit in Armature: Using an ohmmeter, check for continuity between the commutator segments. If there is no continuity (high resistance), the segments are open and armature must be replaced.

Testing Armature for a Short Circuit: Use a growler for locating shorts in the armature. Place armature in growler and hold a thin steel blade (e.g. hacksaw blade) parallel to the core and just above it while slowly rotating armature in growler (Figure 7). A shorted armature will cause the blade to vibrate and be attracted to the core. If armature is shorted, replace with a new one.

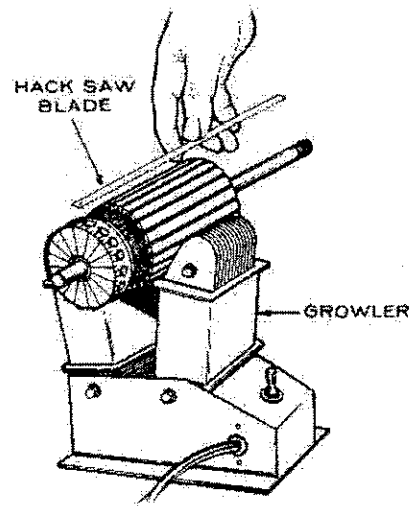

ES-1902

FIGURE 7. TESTING ARMATURE FOR SHORT CIRCUITS

Commutator Inspection: If commutator is dirty or discolored, clean with number 00 to 000 commutator paper. Blow grit out of armature after cleaning.

If commutator is scored, rough, or worn, turn it down in a lathe.

Inertia type starter inspection

Housing Inspection: Permanent magnets are glued to inside of the housing. Magnets must be secure and free of cracks.

Brush Inspection: If brushes are worn shorter than 1/4 inch (6.35 mm), replace them. Check to see that brushes move smoothly in the brush holders. See Figure 8.

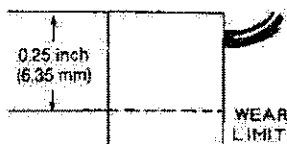

FIGURE 8. BRUSH WEAR LIMIT

Pinion Gear: If pinion gear is badly worn, has broken teeth, or pinion splined sleeve is damaged replace pinion gear and dust cover assembly. If pinion gear is in good condition, wipe armature shaft spline and pinion clean.

Solenoid shift type starter inspection

Field Coil: Use an ohmmeter to check for continuity between brushes. If there is no continuity, the field coil is open and must be replaced. With field coil mounted in the frame, check for continuity between the field coil and frame. Replace frame assembly if there is continuity.

Brushes: Clean around brushes and holders, wiping off all brush dust and dirt. If brushes are worn shorter than 11.5 mm (.4528 inch) replace them (Figure 9).

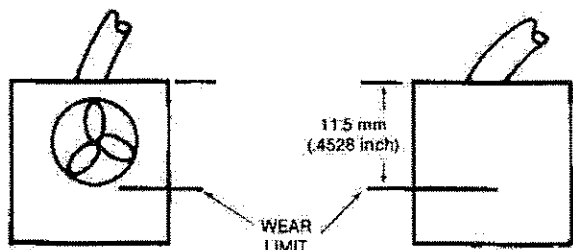

ES-1193

FIGURE 9. BRUSH WEAR LIMIT

Check for shorts between positive side of brush holder and brush holder base. If there is continuity, replace holder assembly. Check for free movement of brushes. All brushes should move freely in the brush holders.

Overrunning Clutch: Inspect pinion and spline teeth for wear or damage.

If pinion gear is worn or damaged, inspect flywheel ring gear also. Rotate pinion. It should turn free when turned in one direction, and lock when turned in the opposite direction.

CAUTION Do not clean overrunning clutch in solvent or liquid cleaning solution. Washing the clutch will cause the grease to leak out.

Solenoid: Push solenoid plunger in and release it. The plunger should return to its original position. While holding plunger all the way in, check for continuity between terminals "M" and "B". If there is no continuity, replace the solenoid (Figure 10). After replacing solenoid check pinion clearance.

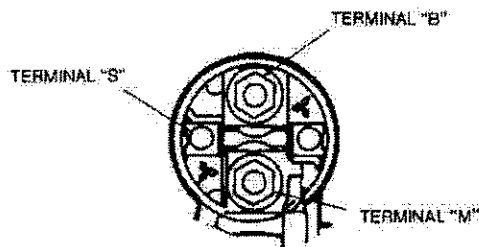

ES-1245

FIGURE 10. SOLENOID TERMINALS

Bushings: If either the front or rear bushing show signs of wear or damage, replace them. Bushing and rear bracket are replaced as an assembly. Check armature shaft thrust gap if rear bracket is replaced.

Remove front bushing by tapping bushing from inside with a 7/16 inch tap. Do not remove cap from front bracket. Thread cap screw, same size as tap, into bushing. Using a slide hammer remove bushing from front bracket. Press new bushing into front bracket. Use care not to distort inside diameter of bushing.

Brush Replacement: Cut old positive brush from pigtail at the brush. Be careful not to damage field coil. Clean 1/4 to 3/8 inch (6.5 to 9.5 mm) of brush end of pigtail with sandpaper or emery cloth (Figure 11).

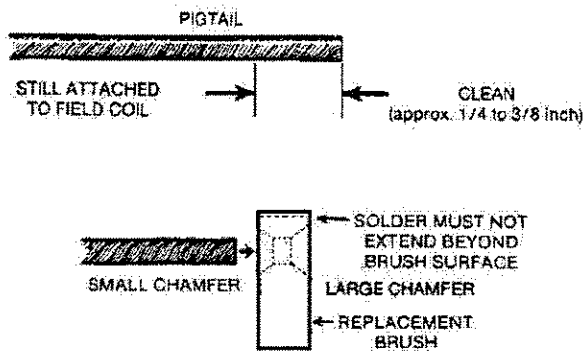

FIGURE 11. BRUSH REPLACEMENT

Push prepared end of pigtail lead into hole in replacement brush from the small chamfered side. Solder pigtail lead to replacement brush on the large chamfered side, using 50/50 tin/lead, rosin core solder and a standard 240/325 Watt soldering iron. Use a file to remove any excess solder that may extend beyond brush surface.

CAUTION *Pigtail lead must not protrude from surface on the soldered side of brush. To prevent stiffening of pigtail lead to not use excessive amount of solder and heat.*

Starter Mounting

Before installing starter motor, make sure the starter mounting surface on the engine base is clean and free of oil.

To install starter on T-260G (Spec A) engines use the following procedure. On these engines starter pinion gear lash requires adjustment and must be checked when starter is installed.

1. Install starter motor and tighten mounting capscrews just enough to hold starter in place.
2. Remove spark plugs from the engine. This allows free movement of the flywheel.
3. Manually pull the starter pinion gear outward on its shaft until pinion gear teeth mesh completely with flywheel ring gear teeth. Energize solenoid on solenoid shift starter.
4. Measure the amount of free travel (lash) between the pinion gear teeth and the ring gear teeth. See Figure 12: If lash is too tight, causing binding and slow starter operation, or if lash is greater than 0.035 inch (0.889 mm), lash must be adjusted.

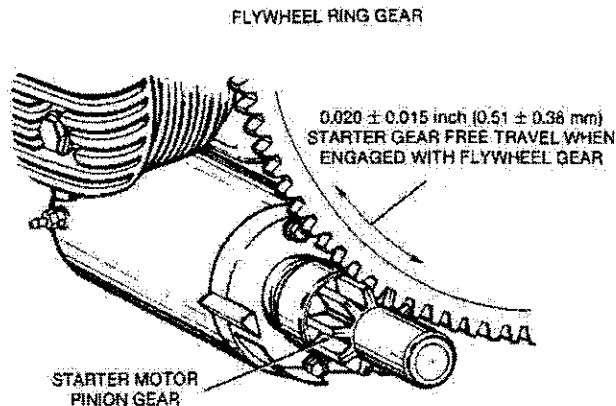

ES-1003

FIGURE 12. CHECKING STARTER GEAR LASH

5. To adjust lash on starters without slotted mounting holes, remove starter. Use a 21/64 inch (8.334 mm) drill to enlarge one mounting hole in starter mounting bracket.
6. Install starter motor and adjust lash to 0.020 in. \pm 0.015 in. (0.51 mm \pm 0.38 mm).
7. Remove flywheel and torque starter mounting capscrews to 24 to 26 ft-lbs (33 to 35 Nm). Use Onan flangehead capscrews or SAE grade 8 capscrews with a hardened flatwasher. Do not use lockwashers.

CAUTION *Failure to torque starter bolts properly may cause starter failure and ring gear damage.*

8. Install flywheel spark plugs, blower housing, and cylinder air housings. For correct cylinder air housing installation (required on some models), refer to Cylinder Air Housing Clearance.
9. Connect battery cable and wires to starter. Connect battery cables to battery. Connect ground cable last.

To install starter on T-260G (Beginning Spec B) engines use the following procedure. On these engines starter pinion gear lash does not require adjustment.

1. Install starter motor and torque mounting capscrews to 24 to 26 ft-lbs (33 to 35 Nm).
2. Install flywheel, blower housing, and cylinder air housing. For correct cylinder air housing installations (required on some models), refer to Cylinder Air Housing Clearance.
3. Connect battery cable and wires to starter. Connect battery cables to battery. Connect ground cable last.

Engine Disassembly

DISASSEMBLY/ASSEMBLY

When complete engine disassembly is necessary, first remove all complete assemblies. Individual assemblies such as fuel pump and carburetor can be disassembled and repaired at another time.

Suggested Disassembly Order

1. Drain crankcase.
2. Disconnect all exhaust lines and electrical lines.
3. Remove engine from its mountings and place on a suitable bench or work stand.
4. Remove all housings, shrouds, blower housings, etc.
5. Remove flywheel, using a puller. Note position of chaff screen and venturi when removing to assure screw hole alignment on reassembly. See page 10-18 for further information.
6. Remove ignition trigger ring, if engine is equipped with electronic ignition.
7. Remove the gear cover, being careful to protect the oil seal from keyway damage.
8. Remove the crank gear, using a gear puller and ring.
9. Remove all accessories such as oil filter, starter, intake manifold, fuel lines, spark plugs, etc.
10. Remove breaker point box.
11. Remove oil base, oil pump and cylinder heads.
12. Remove valves, springs, lifters, etc.
13. Remove camshaft and gear assembly.
14. Remove connecting rods and pistons.
15. Remove rear bearing plate, crankshaft, and front bearing.

Keep all parts in their respective orders. Keep valve assemblies together. Return rod caps to their respective pistons. Analyze the reasons for parts failure.

Suggested Assembly Procedure

Engine assembly is normally the reverse of the disassembly procedure observing proper clearances and torques. Use a torque wrench to assure proper tightness. Coat the internal engine parts with oil as they are assembled. After the internal engine parts are assembled, the engine should turn over by hand freely. Use only genuine Onan parts and special tools when reassembling your engine.

1. Use the proper bearing driver to install front main bearing after coating it with a light film of oil.
2. Insert rear main bearing in rear bearing plate.
3. Insert crankshaft, rear bearing plate, and crankshaft gear.
4. Install piston and connecting rods.
5. Install camshaft and gear assembly; align crank gear mark with cam gear mark.
6. Install valve assemblies, oil pump, oil base, and cylinder heads.
7. Install breaker point box.
8. Install all accessories such as oil filter, starter, fuel lines and spark plugs.
9. Install gear cover with oil seal, trigger ring (electronic ignition only) and flywheel.
10. Set breaker points (if equipped with points) to obtain proper timing.
11. Check valve clearance.
12. Install all housings and air cleaner.
13. Fill crankcase with oil.

Operation

Start engine and check oil pressure. Run for approximately 15 minutes to bring engine to operating temperature. Check for oil leaks, fuel leaks and exhaust leaks. Adjust carburetor and governor for speed and sensitivity.

Testing Compression

The compression tester is used to determine the condition of valves, pistons, piston rings and cylinders.

To check compression:

1. Run the engine until thoroughly warm.
2. Stop engine and remove spark plugs.
3. Remove air cleaner and place throttle and choke in the wide open position.
4. Insert the compression gauge in one spark plug hole.
5. Crank the engine and note the reading.

Refer to *SPECIFICATIONS* section for compression pressures. There may be variations due to equipment, temperature, atmospheric conditions and altitude. These pressures are for a warm engine at cranking speed (about 300 rpm).

Tappet Adjustment

The engine is equipped with adjustable valve tappets. The valve tappet clearance should be checked and adjusted, if necessary, at least every 200 operating hours or when poor engine performance is noticed. Adjust the valve clearance only when engine is at ambient temperature. Proceed as follows:

1. Remove ignition key to prevent accidental starting.
2. Remove all parts necessary to gain access to valve tappets.
3. Remove spark plugs to ease the task of turning the engine over by hand.
4. Place a socket wrench on the flywheel capscrew and rotate the crankshaft in a clockwise direction until the left intake valve (viewed from flywheel end) opens and closes. Continue turning the crankshaft until the TC mark on the flywheel is lined up with the TC mark on the gear cover. This should place the left piston (#1) at the top of its compression stroke. Verify that the left intake and exhaust valves are closed and there is no pressure on the valve lifters.
5. The correct feeler gauge for the valve adjustment (see *SPECIFICATIONS*) should pass freely between valve stem and tappet; a 0.002 inch (0.05 mm) thicker gauge should not (Figure 1).
6. To correct the valve clearance, use a 7/16-inch open end wrench to turn the adjusting screw to obtain the correct clearance. The screw is self-locking and will stay where it is set. A 9/16-inch (14 mm) open end wrench is required to hold the tappet while turning the adjusting screw.
7. To adjust valves on the right hand cylinder, turn engine one complete revolution and again line up mark on the flywheel and the TC mark on the gear cover. Then follow adjustment procedure given for left hand cylinder.
8. Replace all parts removed in Step 2. Tighten all screws securely. Torque manifold bolts to specified torque.

VALVE SYSTEM

A properly functioning valve system is essential for good engine performance. All engines utilize an L-head type valve design as shown in Figure 1. Access to the valve system can be obtained by removing the cylinder heads and the valve covers on top of the engine. A valve spring compressor must be used to remove valves from the cylinder block.

A valve stem seal is sometimes used on the intake valve guides of some engines. This seal must be replaced each time the valve is removed.

Place valves, springs, retainers, and tappets in a rack as they are removed from cylinder block so they can be identified and reinstalled in their original locations. Discard old valve stem seals and replace with new ones during assembly.

Use the following procedures to inspect and service the valve system.

Inspection

Clean carbon from the valves, valve seats, valve guides, and cylinder block.

Valves: Check the valve face for evidence of burning, warpage, out-of-round, and carbon deposits.

Burning and pitting are caused by the valve failing to seat tightly. This condition is often caused by hard carbon particles on the seat. It may also be due to weak valve springs, insufficient tappet clearance, warpage, and misalignment.

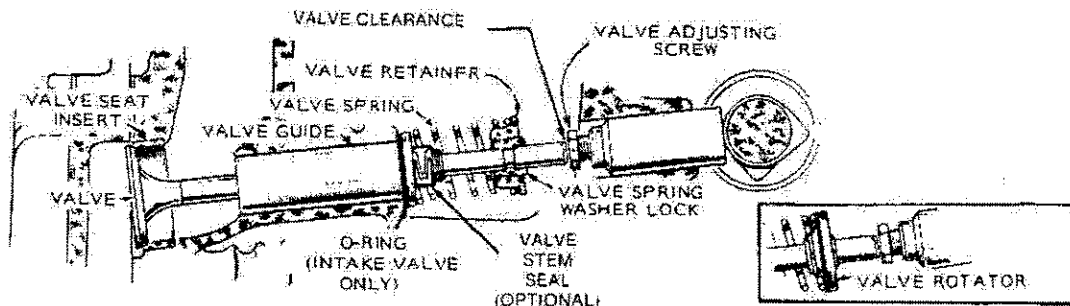
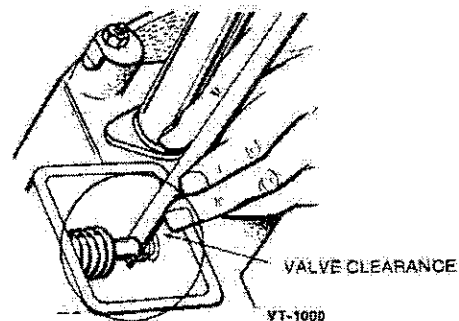

FIGURE 1. VALVE ASSEMBLY

VT-1005

Warpage occurs chiefly in the upper stem due to its exposure to intense heat. Out-of-round wear follows when the seat is pounded by a valve whose head is not in line with the stem and guide. If a valve face is burned or warped, or if the stem is worn, install a new valve.

Too much clearance in the intake guide admits air and oil into the combustion chamber, upsetting carburetion, increasing oil consumption, and making heavy carbon deposits. Carbon reduces heat dissipation. Clean metal is a good heat conductor but carbon insulates and retains heat. This increases combustion chamber temperatures which causes warping and burning.

Unburned carbon residue gums valve stems and causes them to stick in the guide. Deposits of hard carbon with sharp points projecting become white hot and cause pre-ignition and pinging.

Refinish valves that are slightly pitted or burned on an accurate valve grinder. If valves are badly pitted or have a thin margin when refacing, replace them.

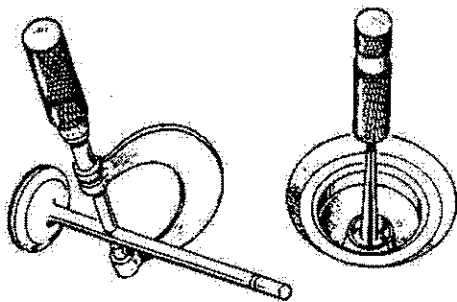

VT-1020

FIGURE 2. VALVE STEM AND VALVE GUIDE INSPECTION

Stems And Guides: Always check valve stems and guides for wear (Figure 2). Use a hole gauge to measure the valve guide. When clearance with stem exceeds that specific in **DIMENSIONS AND CLEARANCES**, replace either valve or guide or both, as may be necessary. Always regrind seat to make concentric with the newly installed guide.

Worn valve stem guides can be replaced from inside the valve chamber (a seal is provided behind the intake valve guides only). The smaller diameter of the tapered valve guides must face toward the valve head. Tappets are also replaceable from the valve chamber after first removing the valve assemblies.

Valve Guide Removal: Before removing valve guides, use an electric drill with a wire brush to remove carbon and other foreign material from top surface of guides. Failure to perform this operation may result in damage to the guide bores. Drive the guides out with a hammer and valve guide driver.

CAUTION Driving out old guides can damage the guide or tappet bores. Be careful not to strike guide bores with driver or allow guide to strike tappet bores during removal.

Valve Guide Installation: Run a small polishing rod covered with crocus cloth through valve guide holes to clean out carbon and other foreign materials. Place a new gasket on the intake valve guide, and coat the outer edge of each new guide with oil. Place guide, notch-up, in cylinder block and press in until guide stops or protrudes 11/32 inch (8.7 mm) from rocker box side of block. A suggested method of installation is shown in Figure 3.

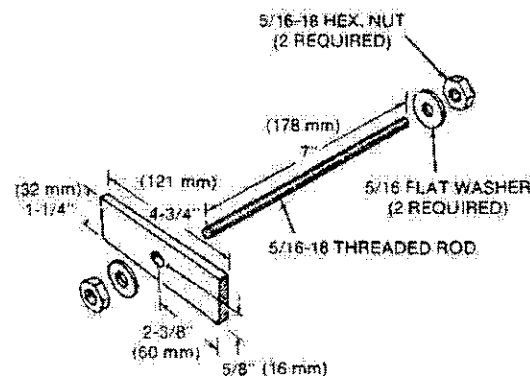
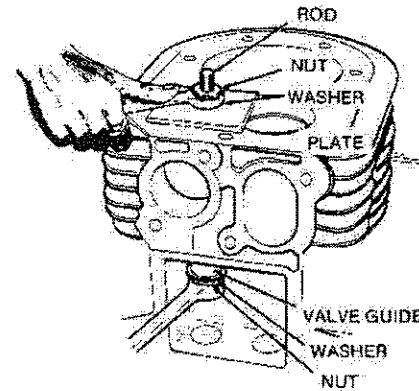

VT-1023

FIGURE 3. VALVE GUIDE INSTALLATION

Valve Stem Seals: Do not reuse valve stem seals. Each time the valves are removed from cylinder block, a new seal must be used when valve is reinstalled.

CAUTION Do not remove valve after seal is installed. Valve can be withdrawn only as far as the groove in valve stem. Do not allow valve stem seal to come in contact with groove or seal damage will result.

Valve Spring: Check valve springs for cracks, worn ends, distortion, and tension. If spring ends are worn, check valve spring retainer for wear. Check for spring distortion by placing spring on a flat surface next to a square. Measure height of spring and rotate it against square edge to measure distortion. If distortion exceeds 0.06 inch (1.5 mm) replace spring. Check spring tension at the installed height for both the valve open and closed position using an accurate valve spring tester. Replace any valve spring that is weak, cracked, worn, or distorted.

Valve Rotators: Positive type valve rotators prolong valve life and decrease valve repairs. When functioning properly, the valve is rotated a fraction of a turn each time it opens. While at open position, the valve must rotate freely. There is no easy way to determine if a valve rotator is good or bad. Onan recommends that valve rotators be replaced at each major overhaul or if a build-up of carbon is noted on valve face and valve seat.

Valve Seats: Inspect valve seat inserts. If seats are loose, cracked or severely pitted, new ones must be installed. Remove valve seat inserts using a valve seat removal tool. If valve seat insert bores in cylinder block are damaged or worn so that a press fit cannot be obtained when installing new standard size valve seat inserts, the bores must be machined for an oversize seat.

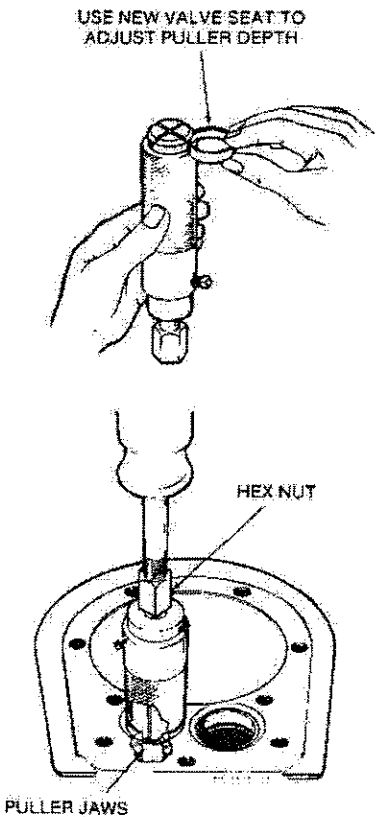

FIGURE 4. VALVE SEAT REMOVAL

Valve Seat Removal: Remove carbon and combustion deposits from valve seat. Select proper puller size determined by inside diameter of valve seat. On some pullers use a new seat as a guide to adjust puller depth (Figure 4). Puller jaws must expand into cylinder block at the point where bottom of valve seat insert rests on cylinder block. Position puller on valve seat and tighten hex nut. Clamp cylinder block to a solid bench. Attach slide hammer to puller. Tighten hex nut between each blow with the slide hammer.

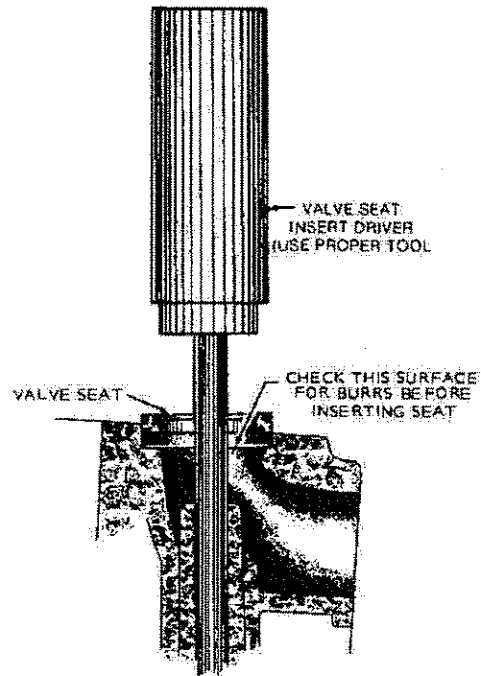

FIGURE 5. INSERTING NEW VALVE SEAT

Valve Seat Installation: After the old seat has been removed, clean out any carbon or metal burrs from the seat insert recess. Use a valve seat insert driver and hammer to install the insert (Figure 5). Drive the valve seat insert in so that the insert enters the recess evenly. Make certain that the valve seat insert rests solidly on the bottom of the recess all the way around its circumference.

To assure a tight valve seat fit and eliminate the danger of seat loosening in the bore, valve seat must be staked.

Insert valve seat staker into valve seat or guide in cylinder block. Using a lead hammer, strike the staking tool a sharp blow to wedge new valve securely in place. It will be necessary to refinish valve seat inserts before installing valves.

TAPPETS

Very little wear takes place on tappet diameters or in tappet bores. If the clearance between tappet and bore in cylinder block exceeds specifications, replace the tappet.

Inspect the tappet faces which contact camshaft lobes for roughness, scuffing, or concave wear. Replace any worn tappets. If tappets are worn, inspect camshaft for wear.

VALVE FACE AND SEAT GRINDING

Some engines are equipped with a premium valve package (aluminized intake valves). If the aluminized valve face does not clean-up using a wire brush, the valve face may be refinished. This removes the aluminized coating from the valve face. An aluminized valve that has been refinished will normally have a life expectancy equal to a standard valve. If longer valve life is required, worn or damaged valves should be replaced with new premium valves.

Before installing new valves or previously used valves, inspect valve seats for proper valve seating. If used valves are reinstalled, the valve stems should be cleaned and valve faces ground to their specified angles of 44° . Refinish valve seats to a 45° angle. When refacing valves and seats, remove all evidence of pitting and grooving. If end of valve stem is pitted or worn, true it and clean it up on the refacer wheel. A very light grind is usually enough to square stem and remove any pits or burrs. The valve guide should be thoroughly cleaned. If valve guide is worn, or valve is warped, the necessary parts must be replaced.

By grinding the valve face and seat at slightly different angles, a fine line of contact on face and seat is obtained, eliminating the need to lap the seating surfaces. The one degree difference in angles is defined as the interference angle (Figure 6). The seat angle is greater than that of the valve face. This assures contact at the maximum diameter on valve seat seating surface.

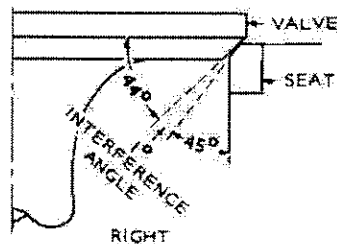

VT-1021

FIGURE 6. VALVE INTERFERENCE ANGLE

Refinish valve faces to a 44° angle on a valve refacing machine. The first cut from valve face must be a light grinding. Check if there is an unevenness of metal being removed. If only part of valve's face has been touched, check to see if valve is properly seated in machine or if valve is warped, worn, or distorted. When cut is even around the whole valve face, keep grinding until complete face is ground clean. Be sure the correct valve face angle is maintained. When valve head is warped, a knife edge will be ground (Figure 7) on part or all of the head due to the large amount of metal that must be removed to completely reface valve. Heavy valve heads are required for strength and good heat dissipation. Knife edges lead to breakage, burning, and pre-ignition due to heat localizing on the edge.

Replace any valve that cannot be entirely refaced while keeping a good valve margin (Figure 7) or is warped, worn, or damaged in any way. The amount of grinding necessary to true a valve indicates whether valve head is worn or warped.

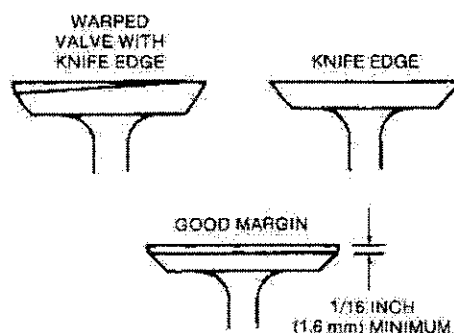

M-1184

FIGURE 7. VALVE HEAD MARGIN

When new valve seats are installed, or previously used seats reground, refinishing must be done with a valve seat grinder used according to the manufacturer's directions.

Valve seats should be ground with a 45° degree stone and the width of the seat band should be $1/32$ inch to $3/64$ inch (0.79 to 1.2 mm) wide. Grind only enough to assure proper seating.

Place each valve in its proper location. Check each valve for a tight seat. Make several marks at regular intervals across the valve face using machinist's bluing. Observe if the marks rub off uniformly when the valve is rotated part of a turn against the seat. The valve seat should contact the valve face evenly at all points. The line of contact should be at the center of the valve face.

FLYWHEEL

Removing the flywheel is a relatively simple process, but the following procedure must be followed to avoid damage to the gear case and possible injury to the operator.

1. Turn the flywheel mounting screw outward about two turns.

⚠ WARNING Do not remove the screw completely since it acts as a restrainer when the flywheel snaps loose. If the flywheel is not held by the screw, the spring action in the wheel will cause it to fly off with great force which can cause injury to the operator.

2. Install a puller bar on the flywheel (Figure 8).

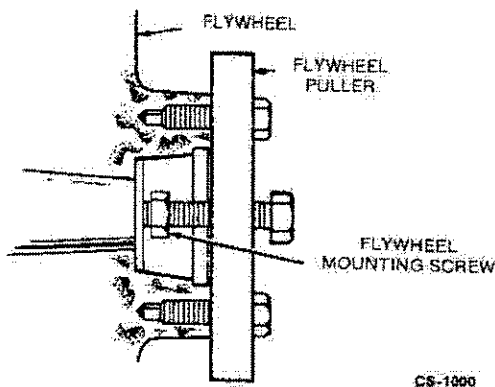

FIGURE 8. BLOWER WHEEL PULLEY

3. Turn the puller bar bolts in, alternately, until the wheel snaps loose on the shaft.

⚠ CAUTION Do not use a screwdriver or similar tool or pry behind the flywheel against the gear case. The gear case cover is die-cast material and will break if undue pressure is applied in this manner.

4. Unscrew the puller from the flywheel, remove the flywheel mounting screw and washer and pull the flywheel off the shaft. Take care not to drop the wheel. A bent or broken fin will destroy the balance. Always use a steel key for mounting the flywheel.

GEAR COVER

After removing the mounting screws, tap the gear cover gently with a soft faced hammer to loosen it.

When installing the gear cover, make sure that the pin in the gear cover engages the nylon lined (smooth) hole in the governor cup (Figure 9). Turn the governor cup so that the nylon lined hole is at the three o'clock position. Use a small amount of grease to assist in holding governor cup in position. The smooth side of the governor yoke must ride against the governor cup. Turn the governor arm and shaft clockwise as far as possible and hold in this position until the gear cover is installed flush against the crankcase. Be careful not to damage the gear cover oil seal.

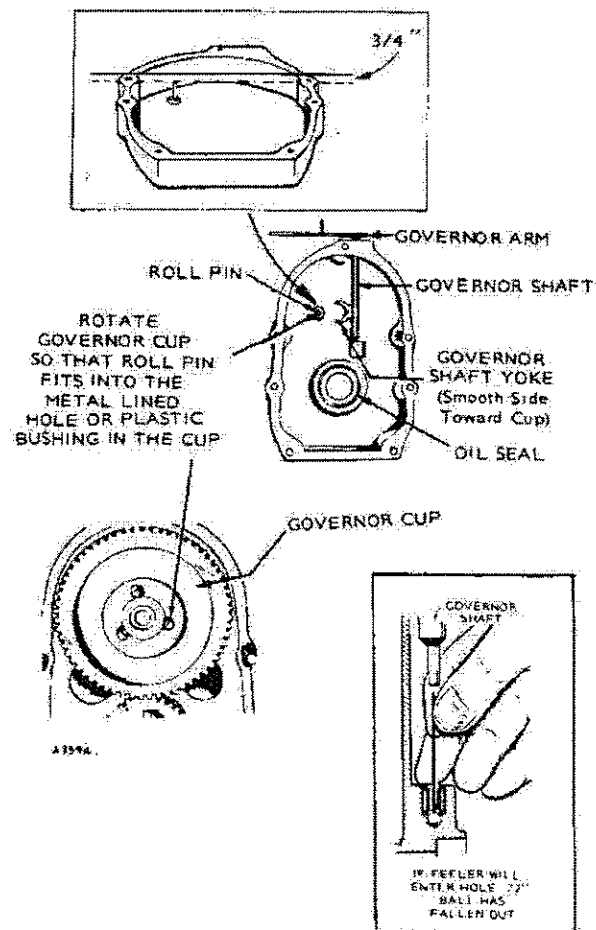
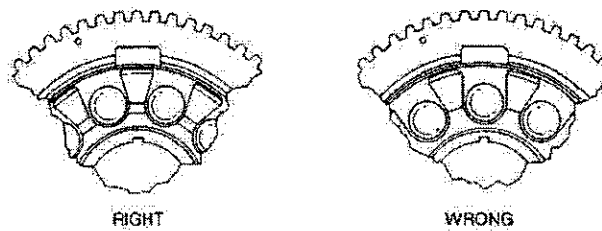
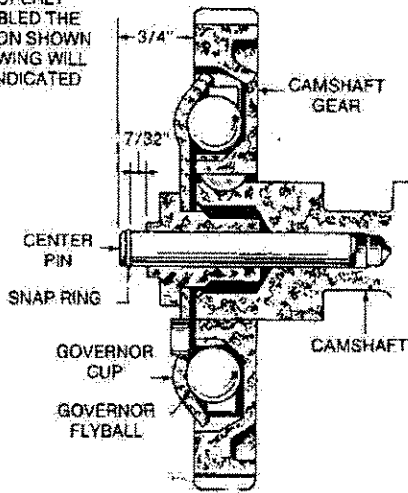

FIGURE 9. GEAR COVER ASSEMBLY

WHEN GOVERNOR IS PROPERLY ASSEMBLED THE DIMENSION SHOWN ON DRAWING WILL BE AS INDICATED



INSTALLATION OF BALL SPACER

C-1107

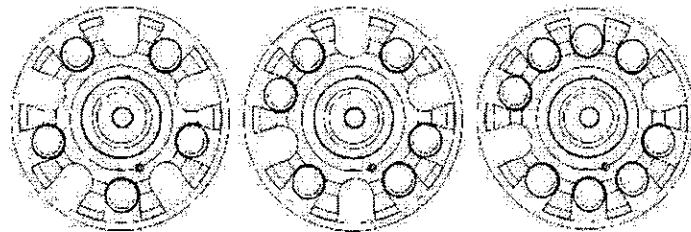

FLYBALL LOCATIONS

CS-1238

FIGURE 10. GOVERNOR CUP DETAILS

GOVERNOR CUP

With the gear cover removed, the governor cup can be taken off after removing the snap ring from the camshaft center pin. Catch the flyballs while sliding the cup off (Figure 10).

Replace with a new part any flyball which is grooved or has a flat spot; the ball spacer if its arms are worn or otherwise damaged; the gear/spacer assembly if loose on gear hub, and the governor cup if the race surface is grooved or rough. The governor cup must be a free-spinning fit on the camshaft center pin, but without any excessive play.

If replacing the ball spacer, be sure to position it so an arm is lined up with the space on the camshaft gear (if your camshaft gear does not have a space in it, disregard this paragraph). If the ball spacer arm is not lined up with the space in the camshaft gear, a flyball can slip into the space and cause engine racing and governing problems (Figure 10).

When installing the governor cup, tilt the engine so the gear is up, put the flyballs in place (Figure 10), and install the cup and snap ring on the center pin.

The camshaft center pin extends out 3/4 inch (19 mm) from the end of the camshaft. This distance provides an in-and-out travel distance of 7/32 inch (5.6 mm) for the governor cup, as illustrated. Hold the cup against the flyballs when measuring. The camshaft center pin

cannot be pulled outward or removed without damage. If the center pin extends out too far, the cup will not hold the flyballs properly. If the distance is less than 7/32" (5.6 mm), (the engine will race, especially at no load) remove the center pin and press in a new pin.

TIMING GEARS

If replacement of either the crankshaft gear or the camshaft gear becomes necessary, always install both gears new.

The camshaft and gear must be replaced as an assembly. Before removing the camshaft and gear assembly, remove the cylinder head and valve assemblies. Then remove the operating plunger for the breaker points and tappets.

To remove the crankshaft gear, first remove the snap ring and retainer washer, then attach the gear pulling ring using two No. 10-32 screws (Figure 11). Tighten the screws alternately until both are tight. Attach a gear puller to the puller ring and proceed to remove the gear.

Each timing gear is stamped with "O" near the edge. The gear teeth must mesh so that these marks exactly coincide when the gears are installed in the engine. When installing the camshaft gear and shaft assembly, be sure that the thrust washer is properly in place behind the camshaft gear. Then install the crankshaft retaining washer and lock ring.

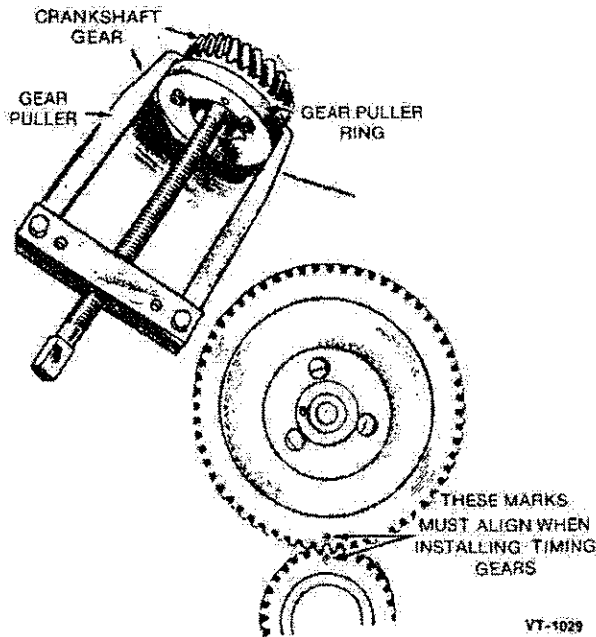

FIGURE 11. TIMING GEAR REMOVAL AND INSTALLATION

PISTONS AND CONNECTING RODS

Observe the following procedure when removing pistons and connecting rods from the engine.

1. Drain oil.
2. Remove the cylinder head and oil base pan from the engine.
3. Remove the ridge from the top of each cylinder with a ridge reamer before attempting piston removal (Figure 12).

CAUTION Forcing the piston from the cylinder before reaming may cause damage to the piston lands and break rings.

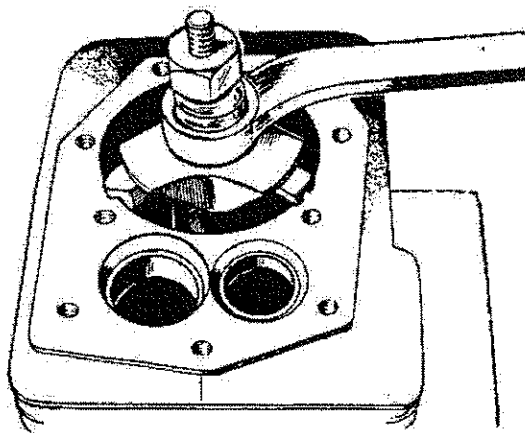

FIGURE 12. REMOVING RIDGE FROM CYLINDER

4. Turn the crankshaft until the piston is at the bottom of its stroke and remove the connecting rod nuts. Lift the rod bearing cap from the rod and push the rod and piston assembly out through the top of the cylinder using a hammer handle. Avoid scratching the crankpin and cylinder wall when removing the piston and rod.
5. Mark each piston and rod assembly so they can be returned to their respective cylinders after overhaul. Keep connecting rod bearing caps with their respective rods.
6. Remove the piston rings from the piston with a piston ring spreader (Figure 13). Remove the piston pin retainer and push the piston pin out.

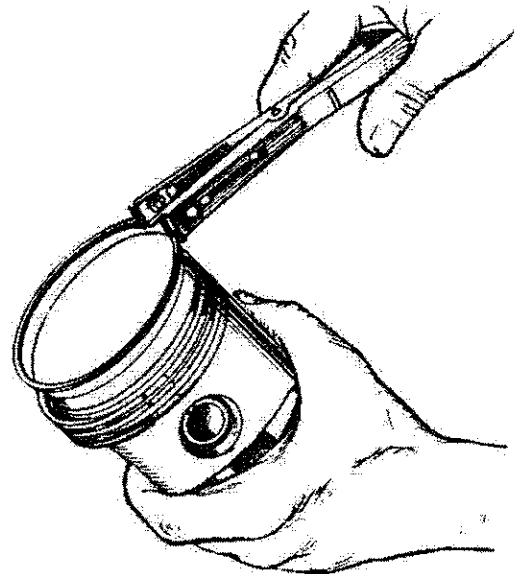

FIGURE 13. REMOVING PISTON RINGS

7. Remove dirt and deposits from the piston surfaces with an approved cleaning solvent. Clean the piston ring grooves with a groove cleaner or the end of a piston ring filed to a sharp point (Figure 14). Care must be taken not to remove metal from the groove sides.

CAUTION Do not use a caustic cleaning solvent or wire brush for cleaning pistons. These materials will cause piston damage.

When cleaning the connecting rods in solvent, be sure to include the rod bore. Blow out all passages with compressed air.

Engines that have been fitted with 0.005 inch (0.13 mm) oversize pistons at the factory are identified by the letter E after the serial number. Number is stamped on the cylinder block and on the unit nameplate.

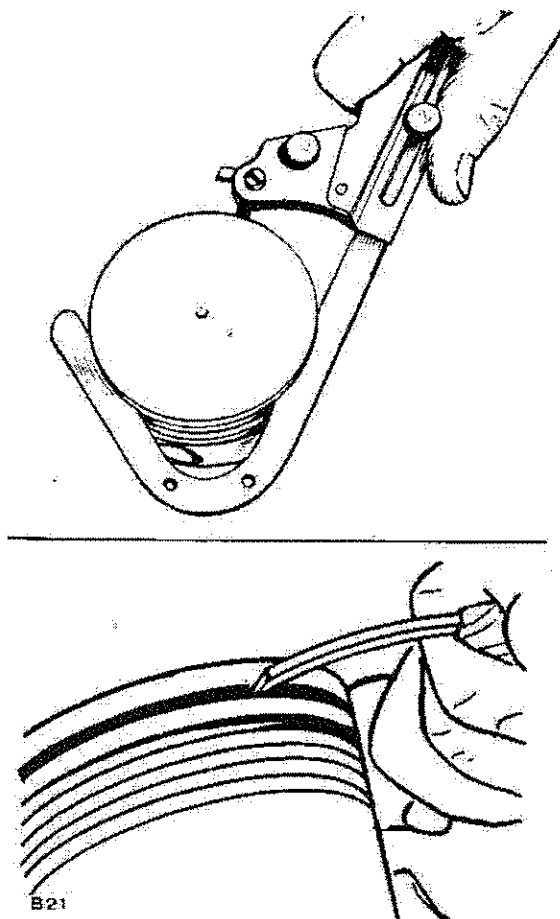

FIGURE 14. PISTON GROOVE CLEANING

Inspection

Follow the procedures given below when inspecting pistons and connecting rods.

Piston Inspection:

1. Inspect the pistons for fractures at the ring lands, skirts, and pin bosses. Check for wear at the ring lands using a new ring and feeler gauge (Figure 15). Replace the piston when the side clearance of the top compression ring reaches 0.008 inch (0.20 mm).
2. Replace pistons showing signs of scuffing, scoring, worn ring lands, fractures or damage from preignition. Excessive piston wear near the edge of the top ring land indicates preignition.

Connecting Rod Inspection:

1. Replace connecting rod bolts and nuts with damaged threads. Replace connecting rods

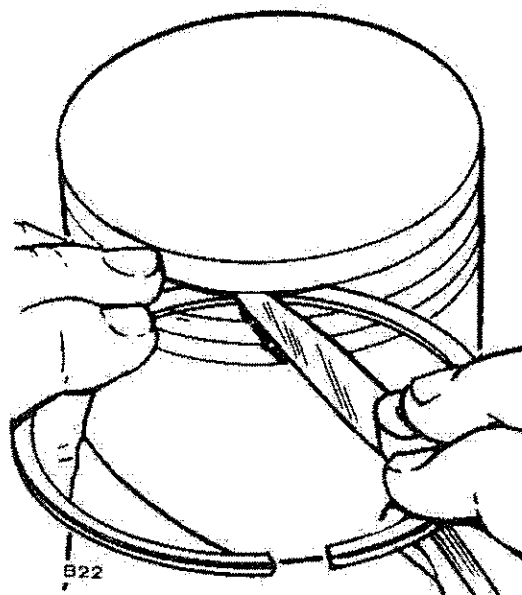

FIGURE 15. CHECKING RING SIDE CLEARANCE

with deep nicks, signs of fractures, scored bores or bores out of round more than 0.002 inch.

2. Use a new piston pin to check connecting rod for wear. A push fit clearance is required and varies from engine to engine. If a new piston pin falls through a dry rod pin bore as a result of its own weight, replace the rod.

Fitting Pistons:

1. Proper piston tolerances must be maintained for satisfactory operation.
2. Refer to *DIMENSIONS AND CLEARANCES* to determine where to measure piston to be sure the total clearance follows specifications.

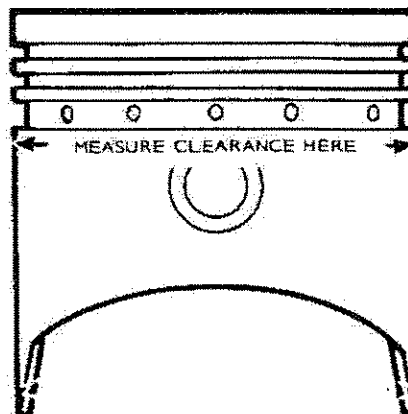

FIGURE 16. MEASURING PISTON CLEARANCE

Fitting Piston Rings:

1. Install the piston ring in the cylinder bore. Invert the piston and push the ring to the end of ring travel, about halfway into the bore, which trues the ring end gap. Check the gap with a feeler gauge (Figure 17).
2. The practice of filing ring ends to increase the end gap is not recommended. If the ring end gap does not meet specifications, check for the correct set of rings and the correct bore size. A cylinder bore that is 0.001 inch (0.03 mm) under size will reduce the end gap 0.003 inch (0.08 mm).

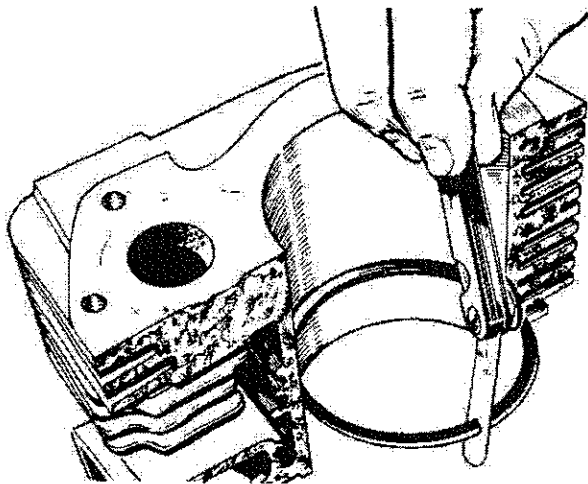
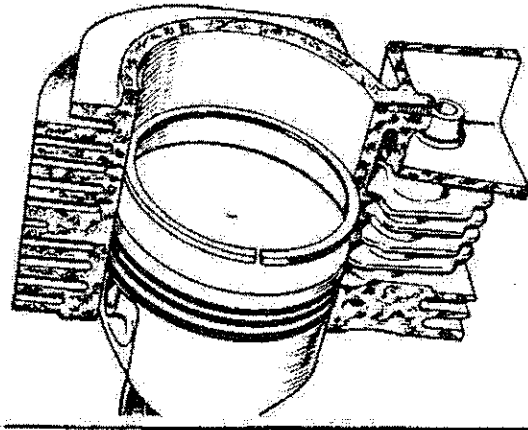

FIGURE 17. POSITIONING OF PISTON RING AND MEASURING OF END GAP

CYLINDER BLOCK

The cylinder block is the main support for all other basic engine parts. Crankshaft and camshaft are supported by the block, assuring alignment of the crankshaft and cylinder bores.

Cleaning

After removing pistons, crankshaft, cylinder heads, etc., inspect block for cracks and extreme wear. If block is still serviceable, prepare it for cleaning as follows:

1. Scrape all old gasket material from block. Remove oil by-pass to allow cleaning solution to contact inside of oil passages.
2. Remove grease and scale from cylinder block by agitating in a bath of commercial cleaning solution or hot soapy washing solution.
3. Rinse block in clean hot water to remove cleaning solution.

Inspection

When rebuilding the engine, thoroughly inspect block for any condition that would make it unfit for further use. This inspection must be made after all parts have been removed and block has been thoroughly cleaned and dried.

1. Make a thorough check for cracks. Minute cracks may be detected by coating the suspected area with a mixture of 25 percent kerosene and 75 percent light motor oil. Wipe the part dry and immediately apply a coating of zinc oxide (white lead) dissolved in wood alcohol. If cracks are present, the white coating will become discolored at the defective area. Always replace a cracked cylinder block.
2. Inspect all machined surfaces and threaded holes. Carefully remove any nicks or burrs from machined surfaces. Clean out tapped holes and clean up any damaged threads.
3. Check top of block for flatness with a straight edge and a feeler gauge.

Cylinder Bore Inspection: Inspect cylinder bores for scuffing, scratches, wear, and scoring. If cylinder bores are scuffed, scratched, scored, or worn, they must be rebored and honed for the next oversize piston.

When the appearance of cylinder bores is good and there are no scuff marks, check cylinder bore for wear or out of roundness as follows:

1. Check cylinder bore for taper, out of round, and wear with a cylinder bore gauge, telescope gauge or inside micrometer. These measurements should be taken at four places, top and bottom of piston ring travel, parallel and perpendicular to axis of crankshaft.
2. Record measurements taken at top and bottom of piston travel as follows (Figure 18).

A. Measure and record as "A" the cylinder bore diameter (parallel to crankshaft) near the top of cylinder bore where greatest amount of wear occurs.

B. Also measure and record as "B" cylinder bore diameter (parallel to crankshaft) at the bottom of piston travel.

C. Measure and record as "C" cylinder bore diameter (perpendicular to crankshaft) near the top of cylinder bore where greatest amount of wear occurs.

D. Also measure and record as "D" cylinder bore diameter (perpendicular to crankshaft) at the bottom of piston travel.

E. Reading "A" subtracted from reading "B" and reading "C" subtracted from reading "D" indicates cylinder taper.

If cylinder taper exceeds that specified in *DIMENSIONS AND CLEARANCES* rebore and hone cylinder to the next oversize.

F. Reading "A" compared to reading "C" and reading "B" compared to reading "D" indicate whether or not cylinder is out of round. If out of round exceeds that specified in *DIMENSIONS AND CLEARANCES* the cylinders must be rebored and honed to the next oversize. A reboring machine is used when going to oversize pistons.

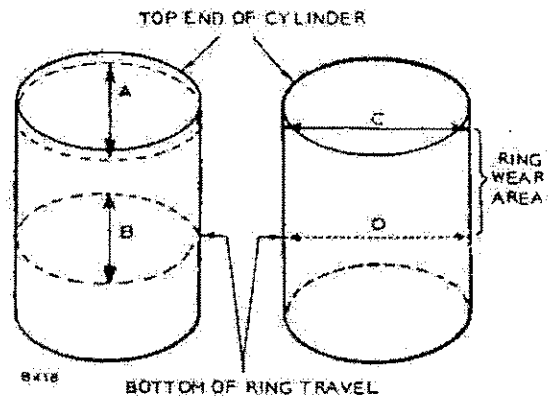
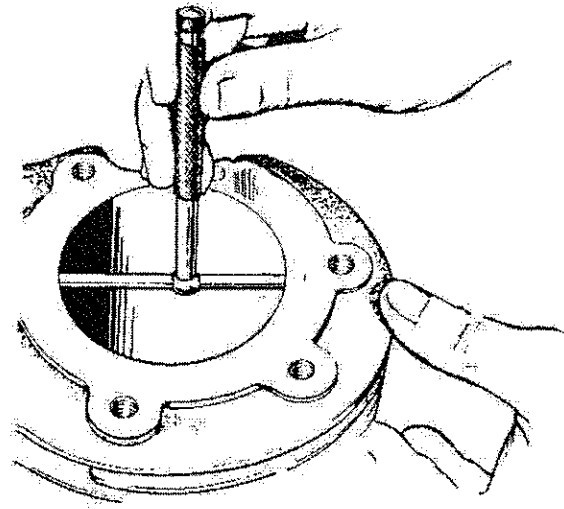

FIGURE 18. METHODS OF MEASURING THE DIAMETER OF A CYLINDER BORE.



Reboring the Cylinder

Rebore and hone engine whenever cylinder bore is worn, damaged, out of round, or if cylinder taper exceeds specifications. A worn cylinder bore should be resized to the smallest standard oversize diameter at which it will clean up. The final finish and bore diameters should then be obtained by honing. Final bore diameter should equal the standard diameter added to the oversize.

CAUTION *If boring bar is operated incorrectly, it will produce a rough cylinder surface that may not clean up even when honed. Boring should be done only by qualified service personnel who are careful in their work.*

After boring to the correct oversize cylinder bore dimension piston and ring clearance should be appropriate. There is no need to adjust or "fit" pistons and rings.

When reboring cylinders, take the following precautions:

1. Make sure cutting tool is properly ground before using it.
2. Be sure top of engine block is smooth and deposit free.

3. Clean base of boring bar before bar is set up. Deposits under boring bar will cause it to tilt and the cylinder will be distorted after boring.
4. Make an initial rough cut, followed by a finish cut. Then hone cylinder bore to the specified oversize.

Honing Cylinders (Using Precision Hones)

Refer to hone manufacturer's recommended grit size to produce specified surface finish of 20 to 40 RMS. Too rough of a finish will wear out the rings and too smooth of a finish can retard piston ring seating.

1. Position block solidly for either vertical or horizontal honing. Use either a drill press or heavy-duty drill which operates at approximately 250 to 450 rpm.
2. Follow hone manufacturer's instructions for the use of oil or lubricant on stones. Do not use lubricants with a dry hone.
3. Insert hone in bore and adjust stones to fit snugly to the narrowest section. When adjusted correctly, the hone should not shake or chatter in cylinder bore, but will drag freely up and down when hone is not running.
4. Connect drill to hone and start drill. Feel out bore for high spots, which cause an increased drag on stones. Move hone up and down in bore with short overlapping strokes about 40 times per minute. Usually bottom of cylinder must be worked out first because it is smaller. As cylinder takes a uniform diameter, move hone up and down all the way through cylinder bore.
5. Check diameter of the cylinder regularly during honing. A dial bore gauge is the easiest method but a telescoping gauge can be used. Check size at six places in bore; measure twice at top, middle and bottom at 90-degree angles.
6. Crosshatch formed by the stones should form an included angle of 23 degrees. This can be achieved by moving the rotating hone (250 to 450 rpm) up and down in cylinder bore about 40 times per minute.
7. Clean cylinder bores thoroughly with soap, water and clean rags. A clean white rag should not become soiled on wall after cleaning is complete. Do not use a solvent or gasoline since they wash oil from the walls but leave the metal particles.
8. Dry crankcase and coat it with oil.

Deglazing Cylinder Bores

Deglaze the cylinder bores if there are no scuff marks and no wear or out of round beyond specifications before installing new rings. Deglazing gives a fine finish, but does not enlarge cylinder diameter, so the original pistons with new rings may still be used.

The reason for deglazing a cylinder is to provide cavities to hold oil during piston ring break-in.

1. Wipe cylinder bores with a clean cloth which has been dipped in clean, light engine oil.
2. Use a brush type deglazing tool with coated bristle tips to produce a crosshatch pattern in the cylinder bore.
3. Use a slow speed drill to drive the deglazing tool. Move deglazing tool up and down in cylinder (10 to 12 complete strokes) rapidly enough to obtain a crosshatch pattern (Figure 19).

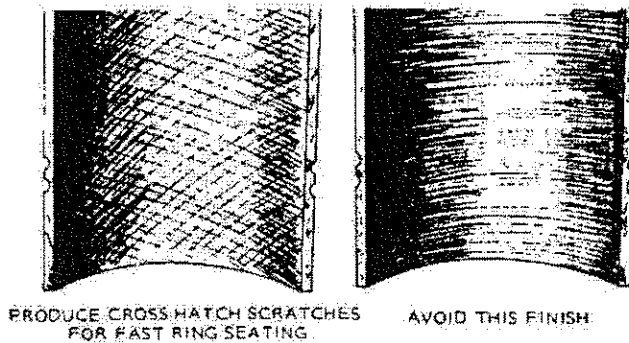

FIGURE 19. CROSS HATCHING

CAUTION Never use gasoline or commercial cleaners to clean cylinder bores after deglazing or honing. These solvents will not remove abrasives from the walls. Abrasives not removed from engine will rapidly wear rings, cylinder walls, and bearing surfaces of all lubricated parts.

4. Clean cylinder bore thoroughly with soap, water and clean rags. Continue cleaning until a clean white rag shows no discoloring when wiped through cylinder bore.

CRANKSHAFT

Clean crankshaft thoroughly and inspect journals for scoring, chipping, cracking, or signs of overheating. If crankshaft has overheated, is scored, or excessively worn, reconditioning or replacement will be required. Examine bearing journals for cracks if overheating has occurred.

Measure crankshaft main bearing and connecting rod journals at several places on their diameter to check for roundness and taper.

The only recommended method of reconditioning the crankshaft is regrinding, as required to accommodate undersize bearings. Metallizing of bearing journals is not recommended.

If regrinding of crankshaft journals is necessary, the work should be done by a reputable machine shop that has suitable equipment to handle precision work of this type. Undersize main bearings are available in sizes of 0.010, 0.020, and 0.030 inch. Undersize connecting rods are available in sizes of 0.010, 0.020, 0.030 and 0.040 inch.

Whenever making major repairs on the engine, always inspect the drilled passages of the crankshaft. Clean them to remove any foreign material and to assure proper lubrication of the connecting rods.

BEARINGS

With camshaft and crankshaft removed, use a micrometer to measure diameter of bearing journals. Use a dial bore gauge or a telescopic gauge and micrometer to measure inside diameter of bearings. Refer to *DIMENSION AND CLEARANCE* to determine if clearances are within specifications.

Any bearing that is scored, chipped, pitted or worn beyond the specified limits must be replaced.

Removal of the camshaft bearings requires complete disassembly of the engine. Use a press or a suitable driver to remove bearings. Support casting to avoid distortion and to avoid damaging the bearing bore during removal and installation.

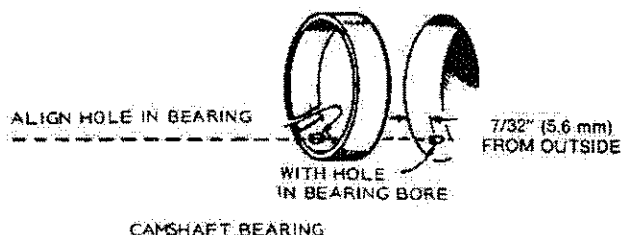

FIGURE 20. FRONT CAMSHAFT BEARING

Replacement camshaft bearings are precision type which do not require line reaming or line boring after installation. Clean outside of the bearing and bearing bore in the block. Before installing cam bearings use Locktite Bearing Mount on outside diameter of bearing. Use a combination bearing driver to install bearings. Place the bearing on the crankcase over the bearing bore with the lubricating hole (front only) in the proper position. Be sure to start the bearing straight. Press in the front bearing flush with the outside end of the bearing bore. Front cam bearing oil hole must line up with oiling hole in cylinder block (Figure 20). Press in the rear camshaft bearing until past the ignition plunger hole. Lubricate bearing surfaces with oil after installing.

New crankshaft main bearings are precision type which do not require line reaming or line boring after installation. Use a press or a suitable driver to remove bearings. Support casting to avoid distortion and to avoid damaging the bearing bore during removal and installation.

Before installing main bearings, expand bearing bore by placing the casting in an oven heated to 200°F (94°C). If practical, cool the precision bearing to shrink it.

Before installing the front main bearing, use the towelette included with the bearing kit to clean the outside of the bearing and bearing bore in the block.

CAUTION Breathing vapor from towelette and prolonged contact with skin can be harmful. Be sure area is well ventilated.

After allowing three to four minutes for drying, apply the Locktite from the small tube to the mating surfaces of the bearing and the bearing bore. Align the oil holes in the bearing with the oil holes in the bearing bore (Figure 22). The oil passage should be at least half open. Install the bearing flush with the block, using the combination driver. Wipe off excess Locktite around the bearing. Allow at least one hour for hardening at room temperature.

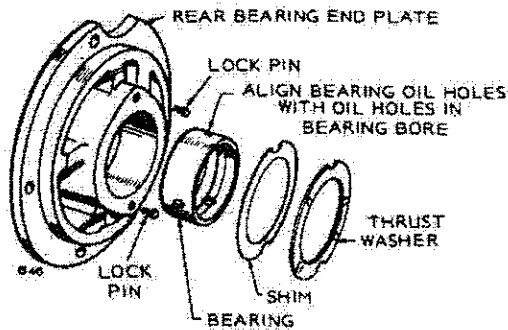

FIGURE 21. BEARINGS FOR REAR BEARING PLATE

In the rear bearing plate, install the bearing flush to 1/64 inch (0.40 mm) below the end of the bore. Be sure to align the oil holes in the bearing with the oil holes in the bearing bore (Figure 21). The oil passage must be at least half open. Lubricate bearing after installation.

If head of lock pin is damaged, use side cutters or Easy Out tool to remove and install new pin. Oil grooves in thrust washers must face the crankshaft, and washers must be flat (not bent). The two notches on each washer must fit over the two lock pins to prevent riding on the crankshaft (Figure 21).

Lubricate the front main bearing lightly with oil and insert the crankshaft. With the rear bearing plate gasket in place and the rear plate bearing lubricated, slide the thrust washer (grooves toward crankshaft) and plate over the end of the crankshaft. Line up notches of thrust washer with lock pins before tightening end plate or lock pins will be damaged.

Engines shipped from the factory have separate thrust washers and main bearings for both front and rear of engine. Front bearing replacement part is a one piece bearing (with attached thrust washer) as shown in Figure 22. Do not add an additional thrust washer to this front bearing.

CRANKSHAFT ENDPLAY

After the rear bearing end plate has been tightened, using the torque recommended in *ASSEMBLY TORQUES AND SPECIAL TOOLS*, check the crankshaft endplay as shown in Figure 23. If there is too much endplay (see *DIMENSIONS AND CLEARANCES* for minimum and maximum endplay), remove the rear bearing end plate and add a shim (Figure 21) between the thrust washer and plate. Reinstall the end plate, making sure the thrust washer and shim notches line up with the lock pins. Torque and recheck endplay of the crankshaft.

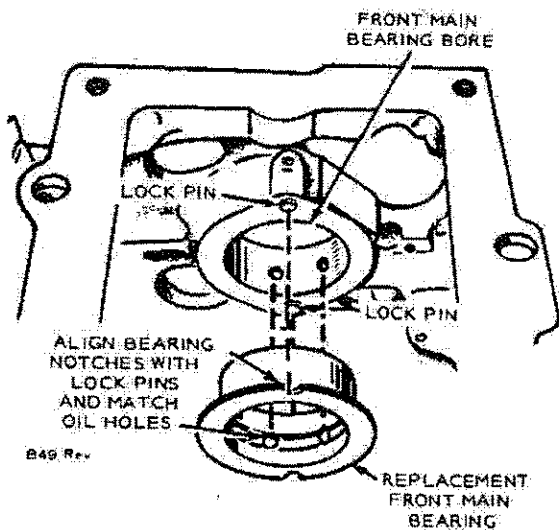

FIGURE 22. FRONT BEARING INSTALLATION

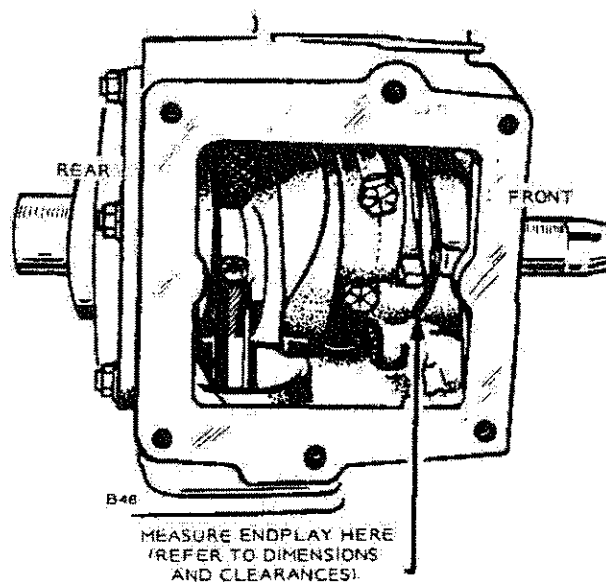

FIGURE 23. CRANKSHAFT ENDOPLAY

CHECKING CONNECTING ROD BEARING CLEARANCE WITH PLASTIGAUGE

1. Make certain that all parts are marked or identified so that they are reinstalled in their original positions. Using a clean dry cloth, thoroughly clean all oil from crankshaft journal and connecting rod.
2. Place a piece of correct size Plastigauge in the bearing cap the full width of the journal surface and about 1/4 inch (6.35 mm) off center (Figure 24).
3. Rotate the crankshaft about 30 degrees from bottom dead center and reinstall the bearing cap; tighten rod bolts to the torque specified in *ASSEMBLY TORQUES AND SPECIAL TOOLS*. Do not turn the crankshaft.
4. Remove bearing cap. The flattened Plastigauge will be found adhering to either the bearing cap or crankshaft.
5. Compare flattened Plastigauge with the graduations on Plastigauge envelope to determine clearance.

The number within the matching graduation on the envelope indicates total clearance in millimetres or thousandths of an inch.

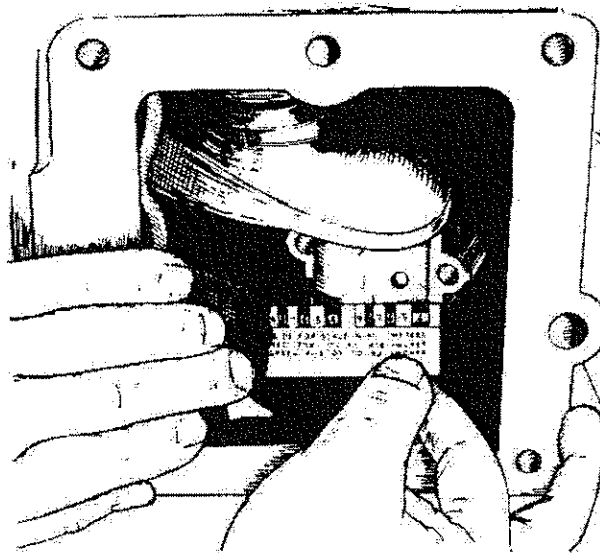

FIGURE 24. MEASURING BEARING CLEARANCE

OIL SEALS

The bearing plate must be removed to replace the oil seal (Figure 25). Drive the oil seal out from the inside.

Before installing seals, fill the space between lips with a multi-purpose grease. This will improve sealing.

When installing the gear cover oil seal, tap the seal inward until it is .645 inch (16.4 mm) from the front of the gear cover.

When installing the bearing plate oil seal, tap the seal into the bearing plate bore to bottom against the shoulder in the plate bore. Use a seal expander or place a piece of heavy paper around the end of the crankshaft, when replacing the bearing plate to avoid damaging the seal. Remove the paper as soon as the plate is in place.

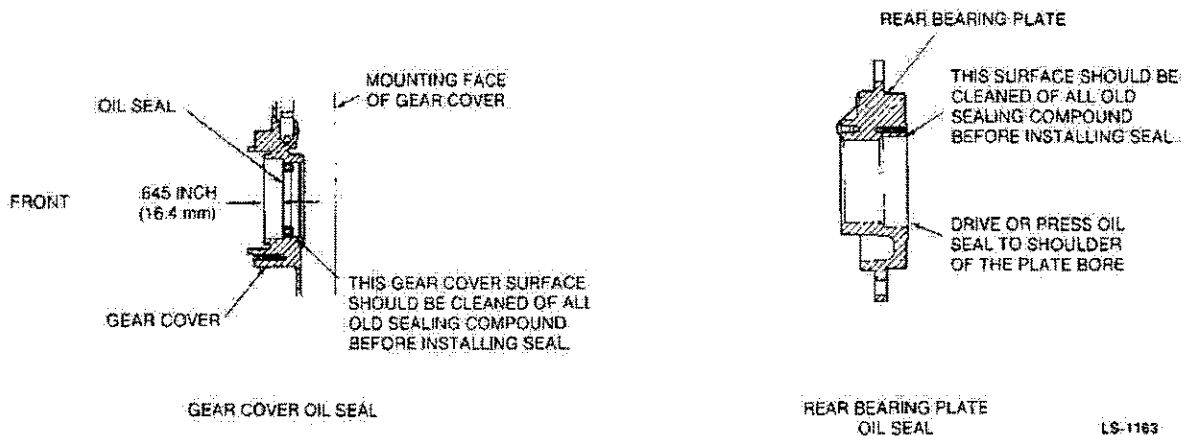

FIGURE 25. GEAR COVER AND REAR BEARING PLATE OIL SEALS

PISTON ASSEMBLY

1. Lubricate all parts with engine oil.
2. Position piston on its respective rod and install the pin.
3. Install the rings on the piston's starting with the oil control ring (Figure 26). Use a piston ring spreader to prevent twisting or excessive expansion of the ring. Compression rings have a dot or the word "top" on one side of the ring to indicate which side faces the top of the piston. Unmarked piston rings can be installed either way. The oil control ring has an expander; install the expander first and then close until the expander ends butt. The joint should be 180 degrees from the gap of that ring.

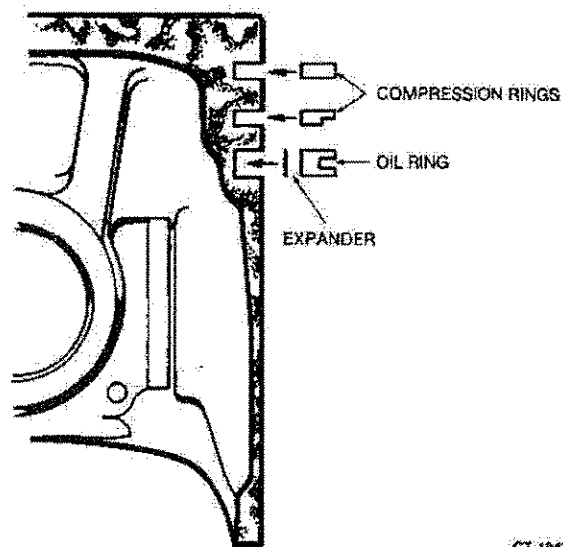
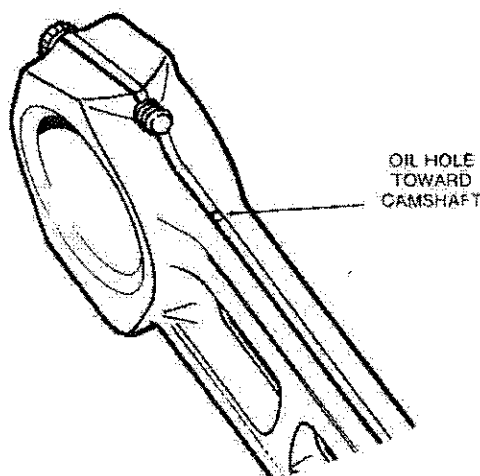

FIGURE 26. PISTON RINGS

INSTALLATION OF PISTON IN CYLINDER

1. Turn the crankshaft to position the number one rod bearing journal at the bottom of its stroke.
2. Lubricate the number one piston assembly and inside of the cylinder. Compress the rings with a ring compressor (Figure 27).
3. Position the piston and rod assembly in the cylinder block. Notched side of connecting rod must face camshaft; rod bolts must be off-set toward outside of block.
4. Tap the piston down into the bore with the handle end of a hammer until the connecting rod is seated on the journal (Figure 27). Install the bearing cap on the rod. Install and tighten the nuts evenly, in steps, to the specified torques.



CT-1077

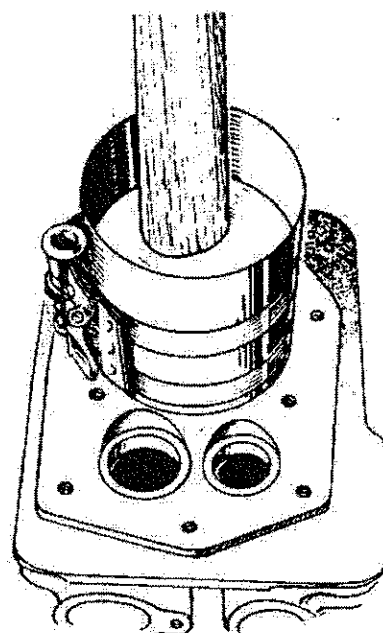

FIGURE 27. INSTALLING PISTON AND CONNECTING ROD

5. The bearing cap must be tapped to properly align it with the rest of the connecting rod. Clearance varies on the journal if this is not done.
6. Install the remaining piston and rod in the same manner. Crank the engine over by hand to see that all bearings are free.
7. Install the oil base with a new gasket.
8. Install the cylinder heads. See *Cylinder Head* section for torques and torquing procedure.
9. Replace oil and break in engine.

CYLINDER HEADS

Remove the cylinder heads for lead cleaning and gasket change at least every 250 hours, or when poor engine performance is noticed.

1. Use a 1/2 inch (13 mm) socket wrench to remove cylinder head nuts. Lift heads off.

CAUTION Do not torque or remove heads when they are hot. Warpage may occur. The gasket surface must be below 100° F before removal. At temperatures above 100° F, the gasket will become gummy and difficult to remove from the surface of the block and cylinder head.

2. After removing heads, clean out all carbon deposits. Be careful not to damage the outer sealing edges where gaskets fit. The heads are made of aluminum and can be damaged by careless handling.
3. Use new head gaskets and clean both the heads and the cylinder block thoroughly where the head gaskets rest.
4. Place a head gasket on the cylinder head and align the stud holes in the gasket with the stud holes in the cylinder head. While holding the gasket against the cylinder head, carefully install the cylinder head on the engine. Do not attempt to slide the gasket over the studs without the cylinder head behind it or the gasket may tear.
5. Install a flat washer, two compression washers, and nut on each of the top six studs (see Figure 28 for correct sequence). When properly installed, only the outside edges of the compression washers will be in contact with each other. Install a flat washer and nut on each of the four bottom studs.

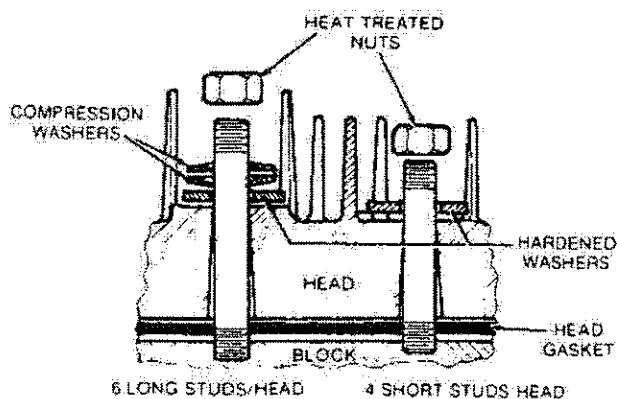

FIGURE 28. CYLINDER HEAD WITH COMPRESSION WASHERS

6. Follow the head torque sequence shown in Figure 29 tightening all nuts to 5 ft-lbs (7 Nm), then 10 ft-lbs (14 Nm), then to the torque specified in the ASSEMBLY TORQUES section. Recheck all nuts for correct torque.

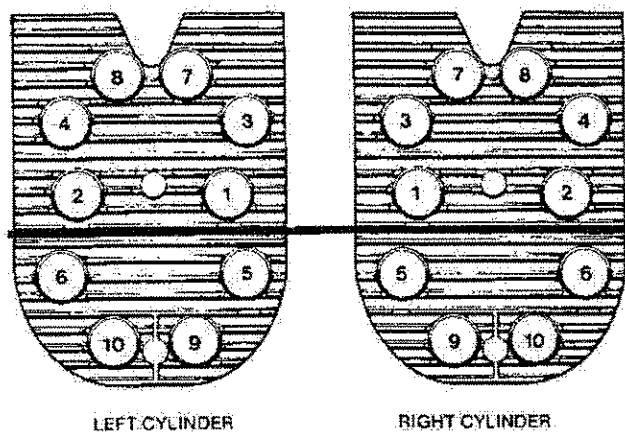

FIGURE 29. HEAD BOLT TIGHTENING SEQUENCE

CAUTION Too much torque will flatten the compression washers and could result in engine damage.

7. Recheck torque before engine has run a total of 50 hours.

CAUTION Do not torque or remove heads when they are hot. Warpage may occur. The gasket surface must be below 100° F before removal. At temperatures above 100° F, the gasket will become gummy and difficult to remove from the surface of the block and cylinder head.

CYLINDER HEAD STUD TEST AND REPLACEMENT PROCEDURE

This cylinder head stud replacement procedure should be used whenever replacing any of the top six studs on the block. The use of Helicoil is not a recommended repair procedure. If a Helicoil has been used, the cylinder block must be replaced. Graphoil head and intake manifold gaskets should also be used when replacing cylinder head studs.

Parts Required

Part No.	Description
520-0912	Step stud
110-2987	Head gasket
154-2219	Intake manifold gasket
420-0398	Drilling fixture (Reusable tool)

1. Disconnect the spark plug wires and remove the spark plugs and cylinder head air shrouds from each cylinder.
2. Remove the nuts and compression washers (do not remove the flatwashers) from the top six studs on each cylinder head (Figure 30). Each stud will have two compression washers and one flatwasher arranged in the sequence shown in Figure 31.

Do not remove the nuts from the bottom four studs before the test procedure is completed.

USE STUDS SHOWN ABOVE LINE FOR SECTION 1 STUD TEST

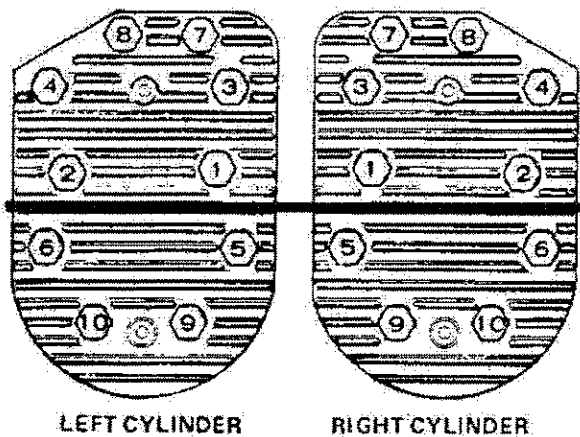

NUMBERS INDICATE CORRECT TIGHTENING SEQUENCE FOR CYLINDER HEAD NUTS

FIGURE 30. CYLINDER HEADS

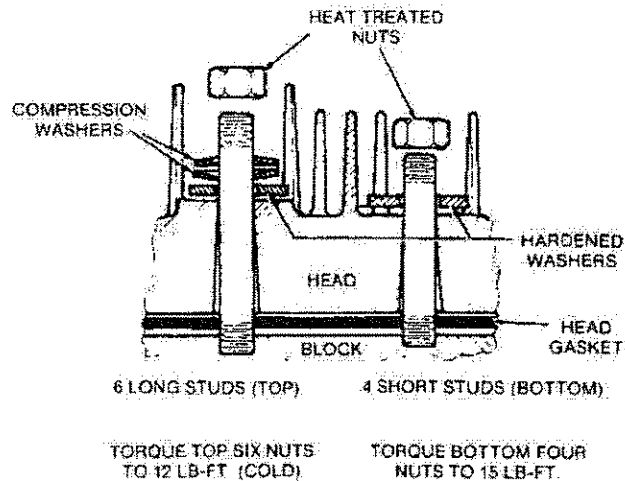

FIGURE 31. CYLINDER HEAD STUDS

3. Replace the nuts and then test the top six cylinder head studs by tightening (use an accurate torque wrench) each nut to 30 ft-lb (40 Nm) of torque. Make a note of any studs that cannot be tightened to 30 ft-lb of torque.
4. Remove the cylinder-head nuts, flatwashers, cylinder head, and head gasket. Discard the head gasket and remove any studs that could not be torqued to 30 ft-lb (40 Nm) without thread pull out.
5. Examine the gasket surfaces of the block and cylinder head for distortion or irregularities that could cause leakage. Check the head and block for warpage by laying a straight edge over the length of the gasket surface. If a 0.005 inch feeler gauge fits between the straight edge and gasket surface, the part must be replaced or milled flat. A maximum of 0.010 inch may be machined from the cylinder block or head.

On some engines, it is possible that a groove from the old head gasket fire ring may be impressed into the head and/or block. If this is the case, it is essential that the part be replaced or milled to remove the imperfection.

If all of the top six studs accepted 30 ft-lb of torque without pulling out, the new head gasket may be put on without replacement of the studs. If this is the case, skip steps 6 through 12.

6. Fit the special repair fixture (Onan Tool #420-0398) to the surface of the block. Use the studs shown in Figure 32 and two cylinder head nuts to secure fixture to head of block.

Some applications may require that three or four flatwashers be placed over the studs between the block and fixture to space the fixture away from the block. This will be necessary if the fixture does not clear the sheet metal scroll backing plate.

7. Insert the small size bushing into the fixture over the hole(s) with damaged threads and lock it in place. With the bushing as a guide, drill out the damaged threads using a 27/64 size drill bit. If drilling out the holes on the SIDE of the block, drill through to the fourth fin (Figure 33). If drilling out the holes at the TOP of the block, it will be necessary to remove the corresponding intake or exhaust manifold. The drill bit should penetrate completely into the port but should not contact the opposite wall of the port (Figure 33).
8. Replace the small bushing with the large bushing and lock into place. Using a 1/2-13 tap, carefully form the threads, making sure there are full threads the entire length of the hole.
9. After all drilling and tapping is completed, remove the special fixture and repeat the same operation on the other cylinder if necessary.
10. Remove the ridge around all new holes using a flat file or a 45° chamfer tool. When using a chamfer tool, the depth of the chamfer should be 1/32 to 1/16 inch deep.
11. Apply screw thread retaining compound (Locktite 242) to the large end of each new step stud. Install the stepped replacement stud, making sure the entire stepped portion is below the gasket surface.
12. When putting a stepped stud into the hole that penetrates into the exhaust port, it will be necessary to cut approximately 3/16 to 1/4 inch (3 threads) off the stepped portion of the stud. No part of this stud may extend into the exhaust port or it will interfere with the exhaust manifold assembly.
13. Turn engine so that both valves are closed. Using a flat scraper and/or wire brush, remove all lead and carbon deposits from the top of the piston, valve area, and cylinder head combustion chamber.

14. Blow out all residual debris and metal chips using low pressure (35 PSI or less) air. If a hole was drilled into either the exhaust or intake port, open the valve on that port and blow it out thoroughly. Replace manifold if removed during the drilling and tapping operations.

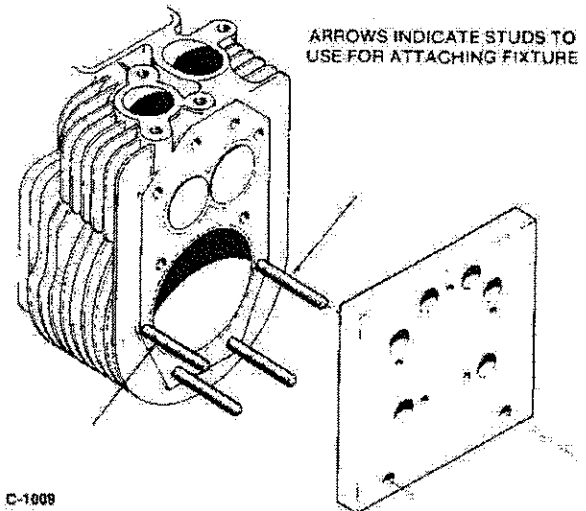

C-1009

FIGURE 32. REPAIR FIXTURE

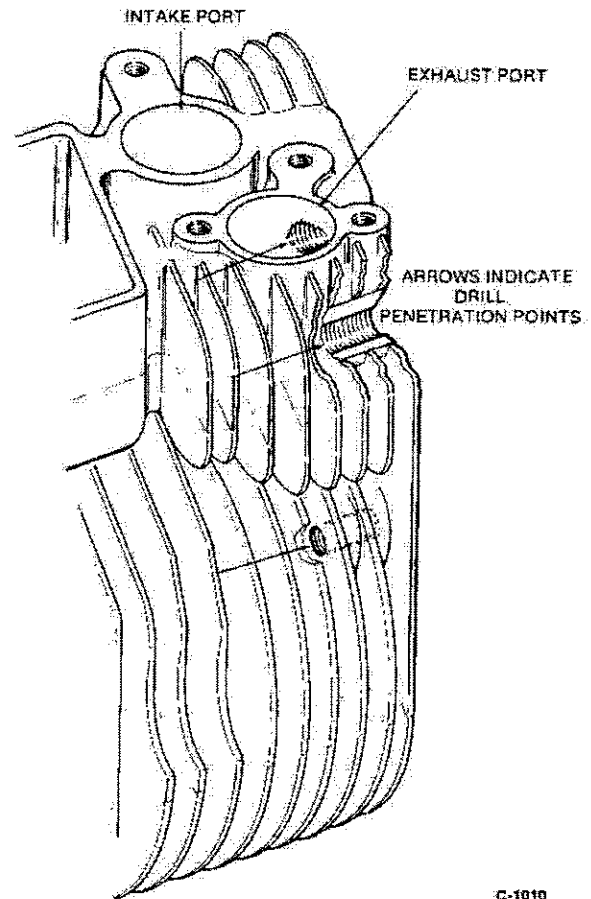

C-1010

FIGURE 33. DRILLING PROCEDURE

ALIGNING BLOWER WHEEL, VENTURI AND CHAFF SCREEN

It may be difficult to line up the screw holes in the blower housing chaff screen with those in the venturi and those in the blower wheel if these parts are separated without noting their relative positions. The holes will match up if the parts are aligned as shown in Figure 34.

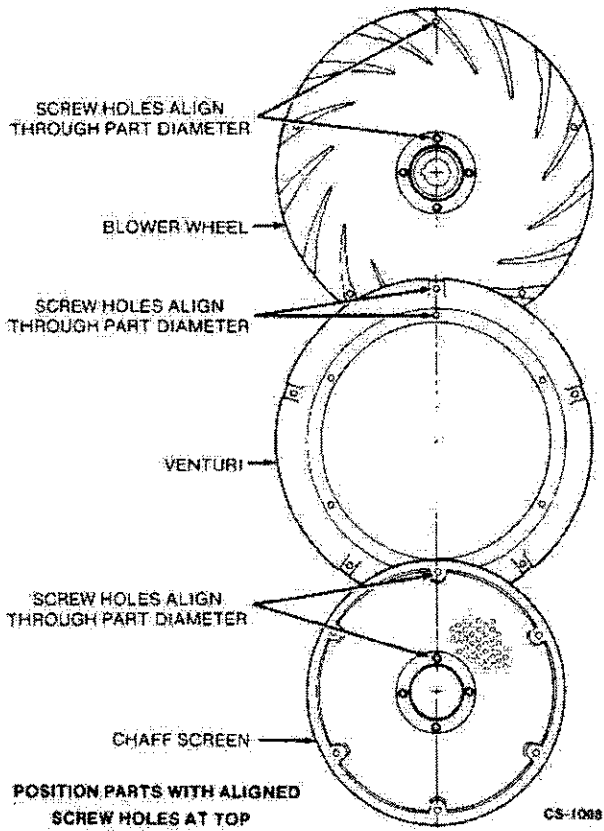

FIGURE 34. BLOWER WHEEL, VENTURI AND CHAFF SCREEN ALIGNMENT