



# TROUBLE SHOOTING GUIDE FOR SUNDSTRAND HEAVY DUTY HYDROSTATIC TRANSMISSIONS

# INSTRUCTIONS

Our experience shows that there are five (5) problem statements that cover the majority of problems encountered with the Heavy Duty hydrostatic transmissions. These problem statements and the page number for the corresponding fault-logic diagrams are listed below.

Neutral Difficult or Impossible to find	Page 1
System Operating Hot	Page 2
System Operates in one Direction Only	Page 3
System Response Sluggish	Page 4
System will not operate in either Direction	Page 5

Following the fault-logic diagrams are descriptions of some of the action steps shown in the diagrams. Where applicable the page number for this description appears in the action block of the diagram. These descriptions and the corresponding page numbers are listed below.

Inspect Control Valve	Page 6
Inspect High Pressure Relief Valves	Page 7
Inspect Shuttle Valve	Page 7
Inspect Charge Check Valves	Page 8
Check Charge Pressure	Page 9
Inspect Charge Pump	Page 9
Inspect Charge Relief Valve @ Pump	Page 9
Inspect Charge Relief Valve @ Motor	Page 9

# INTRODUCTION

The information contained in this bulletin provides a guide for trouble shooting the Sundstrand Heavy Duty hydrostatic transmissions. It is a problem solving tool aimed at eliminating unnecessary machine downtime. Following the fault-logic approach presented in this guide should result in the expedient correction of transmission problems.

**NEUTRAL DIFFICULT  
OR  
IMPOSSIBLE TO FIND**

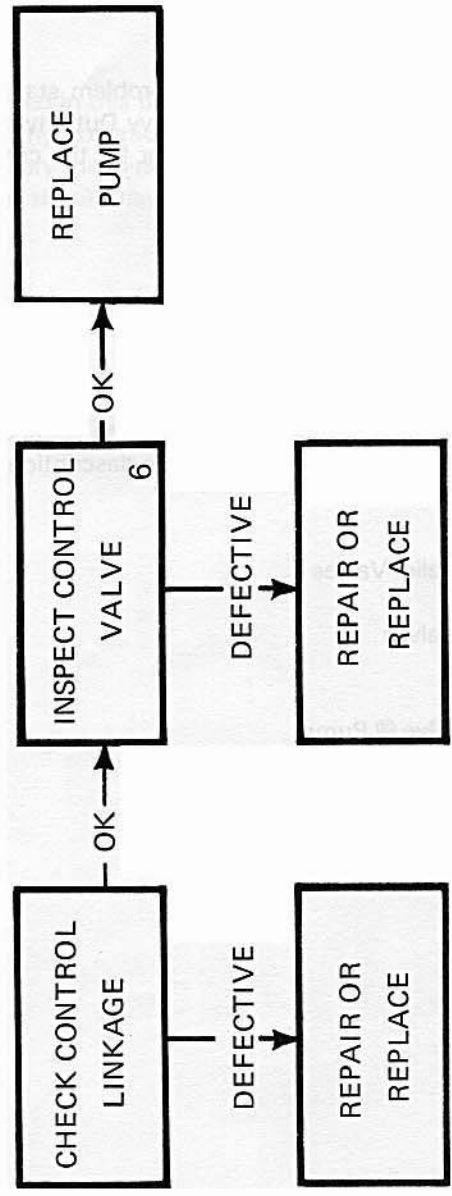

# SYSTEM OPERATING HOT

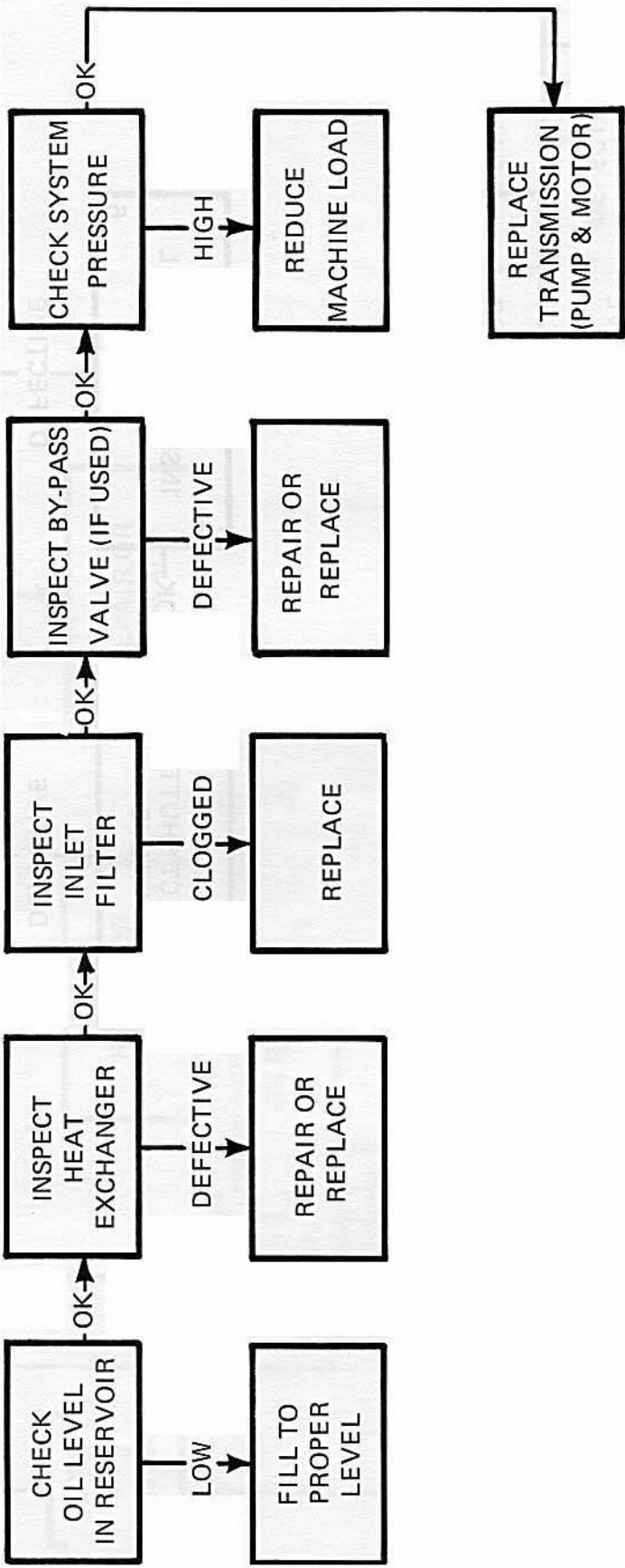

# TRANSMISSION OPERATES IN ONE DIRECTION ONLY

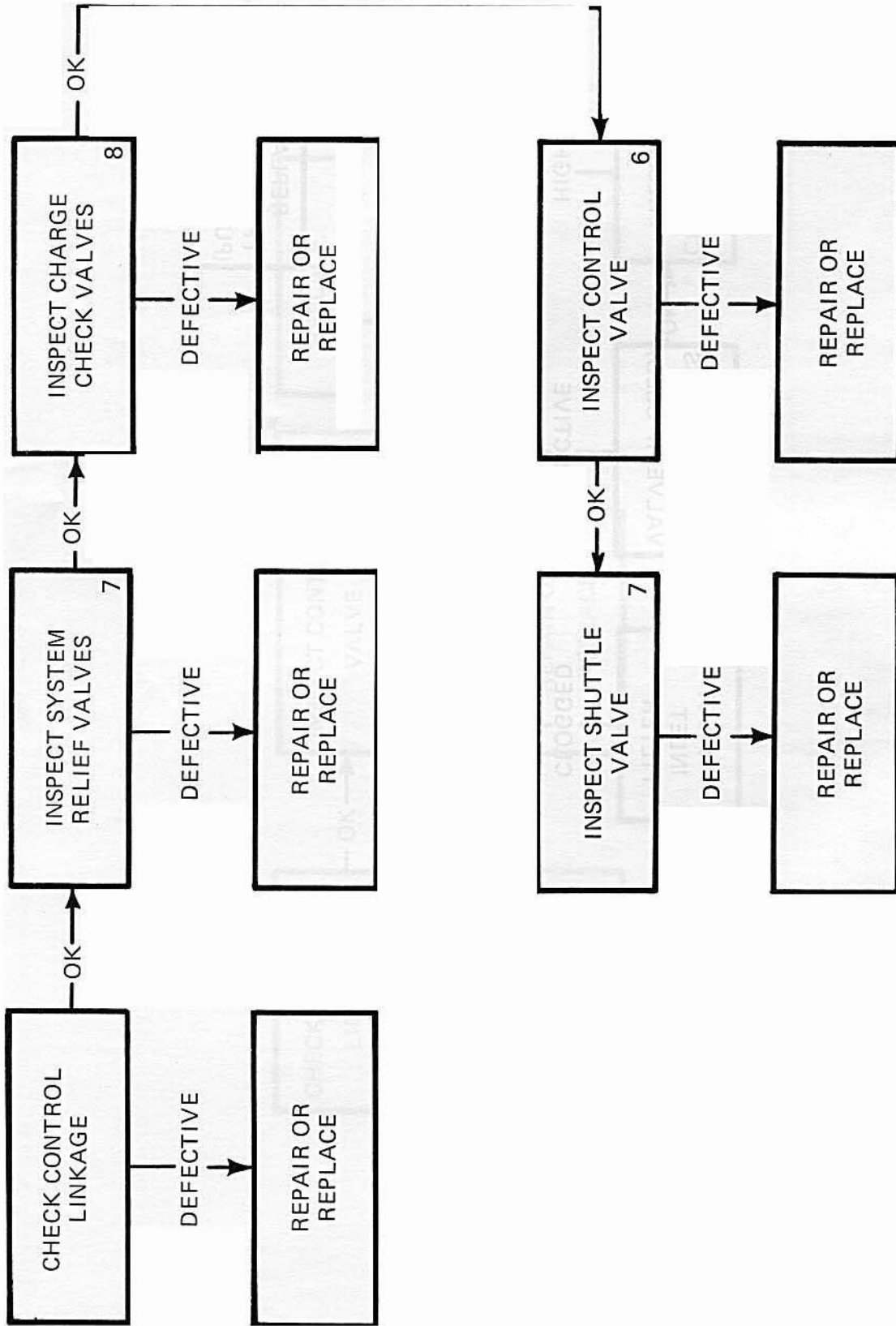

# SYSTEM RESPONSE SLUGGISH

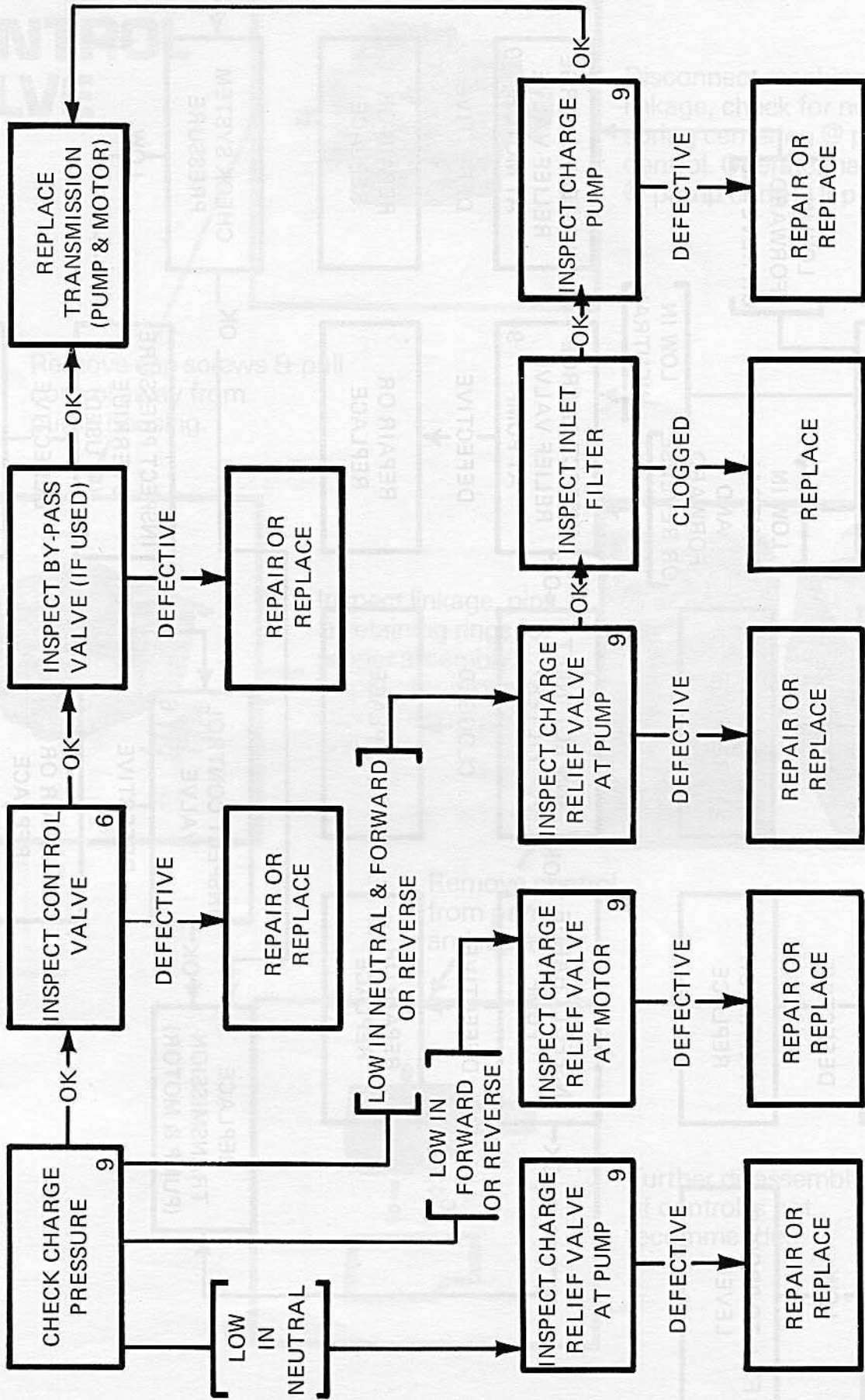

# SYSTEM WILL NOT OPERATE IN EITHER DIRECTION

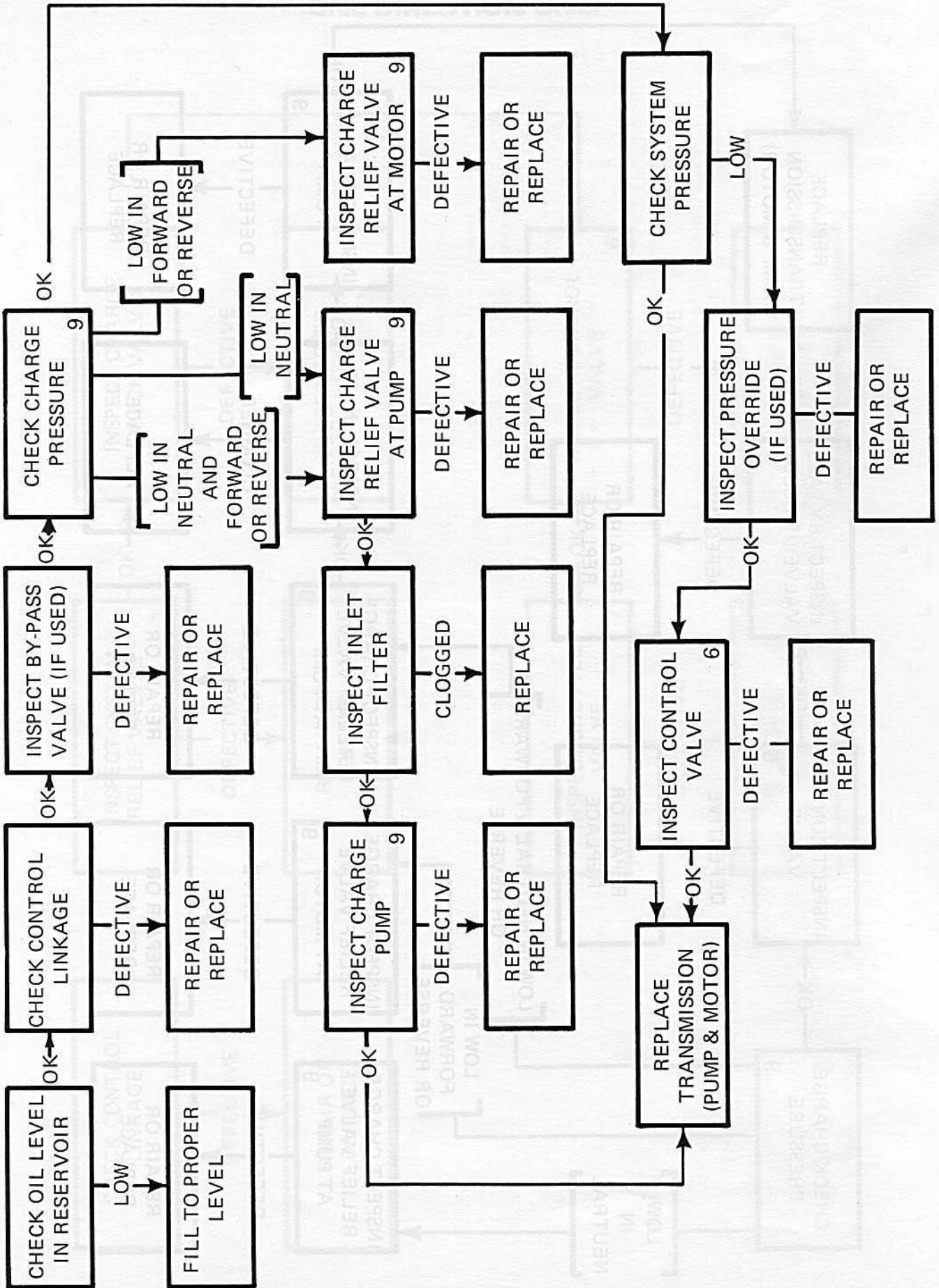

# INSPECT CONTROL VALVE

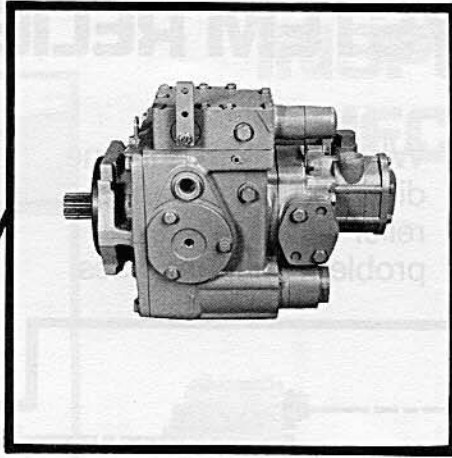

Disconnect machine linkage, check for neutral & spring centering @ pump control. Operate machine @ pump control if possible.

Remove cap screws & pull control away from pump housing.

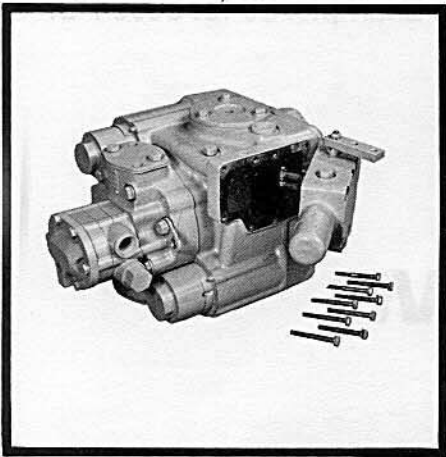

Inspect linkage, pins & retaining rings for proper assembly. Inspect for broken spring or plugged orifice.

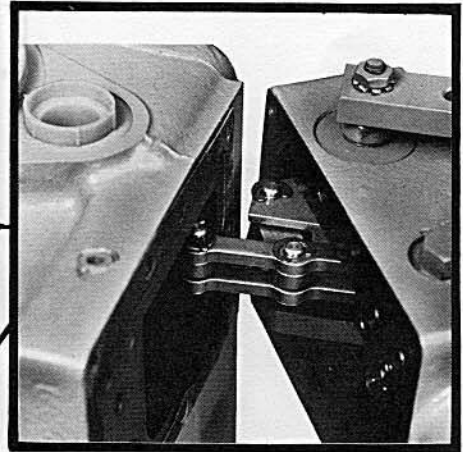

Remove control from pump and replace.

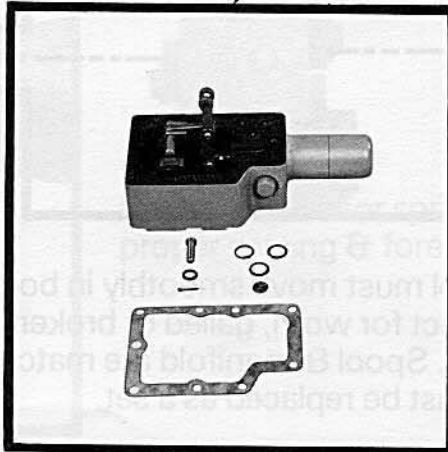

Further disassembly of control is not recommended.

# INSPECT SYSTEM RELIEF VALVES

When problem is in one direction, interchange relief valves to see if problem changes sides.

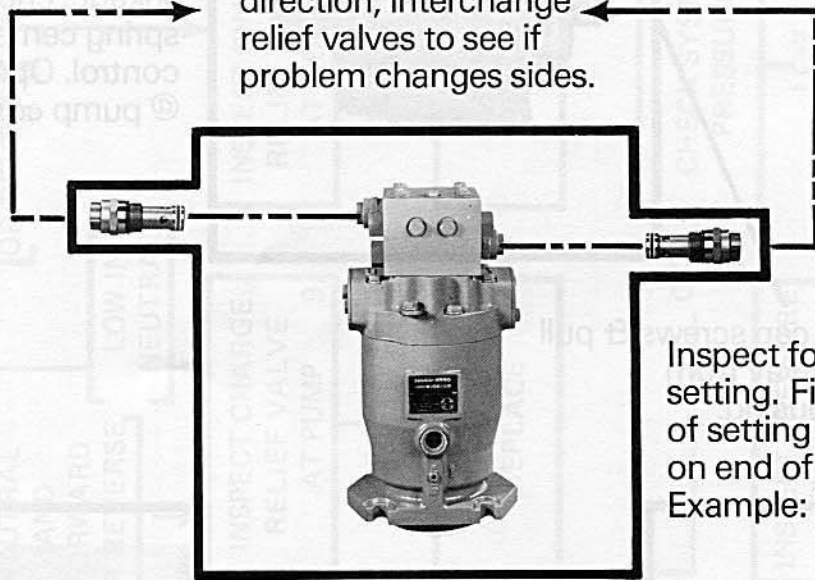

Inspect for proper setting. First two (2) digits of setting are stamped on end of valve.  
Example: 30 for 3000 PSI

# INSPECT SHUTTLE VALVE

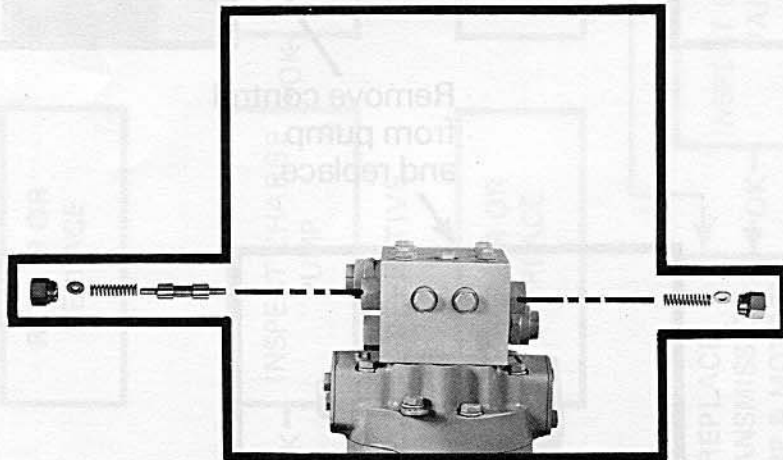

Spool must move smoothly in bore. Inspect for worn, galled or broken parts. Spool & manifold are matched & must be replaced as a set.

# INSPECT CHARGE CHECK VALVES

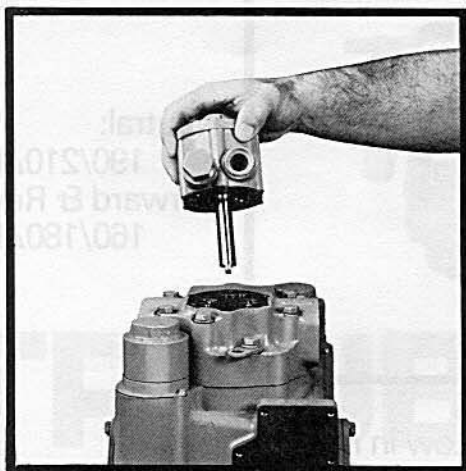

Remove Charge Pump  
& Charge Check Valves

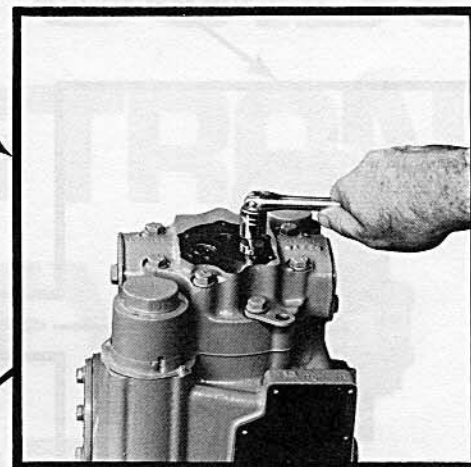

When problem is in one direction,  
interchange check valves to see  
if problem changes sides.



Inspect valves for spring load,  
proper seating & foreign material.

# CHECK CHARGE PRESSURE

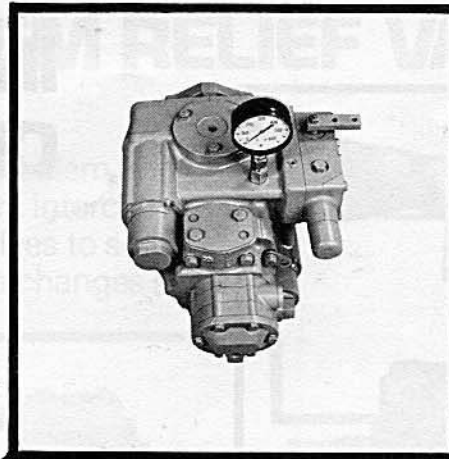

Neutral:  
190/210ΔPSI  
Forward & Reverse  
160/180ΔPSI

Low in fwd. & reverse  
(OK in neutral)

Inspect charge relief  
valve @ motor

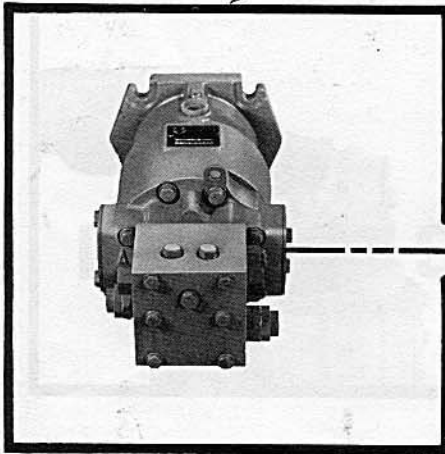

Inspect for foreign material  
holding poppet open, galling  
or wear on poppet & seat,  
broken spring or improper  
setting.

Low in neutral  
(Low or okay in fwd. & reverse)

Inspect charge relief  
valve @ pump

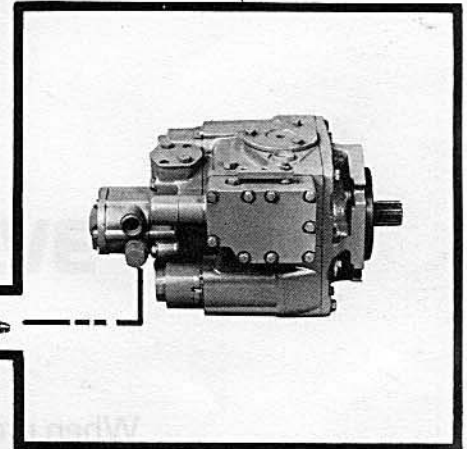

Inspect for foreign material  
holding poppet open,  
galling or wear on poppet  
& seat, broken spring or  
improper setting.

Low in neutral and fwd.  
& reverse

Inspect charge pump

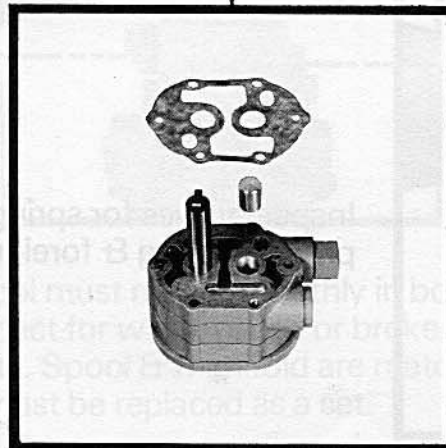

Shaft & internal gears  
must turn smoothly.

Further disassembly  
of charge pump is  
not recommended.