

TECUMSEH

Basic

Troubleshooting and Service Information



ENGINES & TRANSMISSIONS

TABLE OF CONTENTS

Safety Definitions	ii
General Safety Precautions	1
General Information.....	2
Reviewing The Engine ID Label	3
Model Numbering Identification for Tecumseh's Full Engine Line	4
Spark Plug Replacement (4-Cycle)	5
Spark Plug Replacement (2-Cycle and Europa)	6
Fuel Recommendations	7-8
Tecumseh 4-Cycle Lubrication Requirements	9
4-Cycle Troubleshooting.....	10-11
Tecumseh 2-Cycle Engine Oil Requirements	12
2-Cycle Troubleshooting.....	13-14
4-Cycle Cross Reference for Specification-To-Model Number Designation (Vertical Engines).....	15
4-Cycle Cross Reference for Specification-To-Model Number Designation (Horizontal Engines)	16
2-Cycle Cross Reference for Specification-To-Model Number Designation (Vertical and Horizontal Engines)	16
Tecumseh and Peerless® Model and Specification Numbers.....	17-18
Basic Gear Drive Troubleshooting.....	19-20
Tecumseh and Peerless® Transmission, Transaxle and Gear Products.....	21
LTH 2000 Series Hydrostatic Transaxle Troubleshooting.....	21-22
1800 / VST Troubleshooting	23
Tecumseh and Peerless® Lubrication Requirements.....	24
Repair Manuals	25

The information in this guide is intended to assist individuals who are knowledgeable in basic engine repair and maintenance. If you are unfamiliar with two and four cycle engine operation and maintenance, DO NOT attempt any maintenance or repairs. Contact your local Tecumseh Servicing Dealer for assistance.

IMPORTANT NOTICE!

Safety Definitions

Statements in this manual preceded by the following words and graphics are of special significance:



Or



WARNING indicates a potentially hazardous situation which if not avoided, could result in death or serious injury.

NOTE

Refers to important information and is placed in italic type.

It is recommended that you take special notice of all items discussed on the next two pages and wear the appropriate safety equipment.

Before operating an engine *it is your responsibility* to read the Operator's Manual. Follow these basic rules for your personal safety:

- Keep this manual handy at all times for future reference.
- Read it carefully and familiarize yourself with operating, maintenance, components and safety instructions.

Notice Regarding Emissions

Engines which are certified to comply with California and U.S. EPA emission regulations for SORE (Small Off Road Equipment), are certified to operate on regular unleaded gasoline, and may include the following emission control systems: (EM) Engine Modification and (TWC) Three-Way Catalyst (if so equipped).

Tecumseh Contact Information

For engine adjustments, repairs or warranty service, contact your nearest Authorized Tecumseh Servicing Dealer. Find them on our website at www.TecumsehPower.com or call Tecumseh Power Company at 1-800-558-5402 or 262-377-2700 if you are located outside the U.S.

General Safety Precautions

A. Avoid Carbon Monoxide Poisoning

All engine exhaust contains carbon monoxide, a deadly gas. Breathing carbon monoxide can cause headaches, dizziness, drowsiness, nausea, confusion and eventually death.

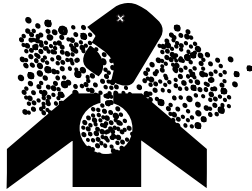

Carbon monoxide is a colorless, odorless, tasteless gas which may be present even if you do not see or smell any engine exhaust. Deadly levels of carbon monoxide can collect rapidly and you can quickly be overcome and unable to save yourself. Also, deadly levels of carbon monoxide can linger for hours or days in enclosed or poorly-ventilated areas. If you experience any symptoms of carbon monoxide poisoning, leave the area immediately, get fresh air, and **SEEK MEDICAL TREATMENT**.

To prevent serious injury or death from carbon monoxide:

- NEVER run engine indoors. Even if you try to ventilate engine exhaust with fans or open windows and doors, carbon monoxide can rapidly reach dangerous levels.
- NEVER run engine in poorly-ventilated or partially enclosed areas such as barns, garages, basements, carports, under dwellings, or in pits.
- NEVER run engine outdoors where engine exhaust can be drawn into a building through openings such as windows and doors.

B. Avoid Gasoline Fires

Gasoline (fuel) vapors are highly flammable and can explode. Fuel vapors can spread and be ignited by a spark or flame many feet away from engine. To prevent injury or death from fuel fires, follow these instructions:



- NEVER store engine with fuel in fuel tank inside a building with potential sources of ignition such as hot water and space heaters, clothes dryers, electric motors, etc.
- NEVER remove fuel cap or add fuel when engine is running.
- NEVER start or operate the engine with fuel fill cap removed.
- Allow engine to cool before refueling.
- NEVER fill fuel tank indoors. Fill fuel tank outdoors in a well-ventilated area.
- DO NOT smoke while refueling tank.
- Use only an approved red GASOLINE container to

store and dispense fuel. Tecumseh recommends purchasing gasoline in containers with a capacity of 2.5 gallons or less. Small containers are easier to handle and help eliminate spillage during refueling.

- DO NOT pour fuel from engine or siphon fuel by mouth.

C. Adult Supervision of Operation, Refueling and Maintenance

Not everyone who is allowed to use an engine is capable of safely and responsibly operating, maintaining and/or fueling it. Tecumseh recommends the following:

- An adult should fuel the engine. NEVER allow children to refuel an engine.
- An adult should perform maintenance on an engine. Only allow children to perform maintenance if an adult has determined they are experienced and capable of such operation.
- An adult should start the engine. Only allow children to start the engine if an adult has determined they are experienced and capable of such operation.

To avoid unsupervised operation of the engine, especially by children, NEVER leave it unattended when it is running.

D. Stay Away from Rotating Parts

NEVER operate an engine with an unguarded engine shaft.

The equipment manufacturer may attach a sprocket and chain or pulley and belt to the engine shaft. If these parts are not properly guarded, or if you are not sure whether they are properly guarded, DO NOT use your engine; contact the equipment manufacturer. Hands, feet, hair, jewelry, clothing, etc. can become entangled in rotating parts, leading to serious injury or death. To avoid serious injury or death, be sure the flywheel guard is in place.



General Information

The following information is being provided to assist you in locating and recording your engine model and specification numbers. This information will be needed to use this book or obtain parts from a local Tecumseh dealer.

Model Numbering System for Tecumseh's Full Engine Line Prior to 2004 Production

LOCATING AND READING ENGINE MODEL AND SPECIFICATION
 THE FOLLOWING WILL BE NEEDED TO LOCATE PARTS FOR YOUR ENGINE.

	Model	Specification	(DOM)
ENGINE:	TVM195	150288G	8150C

ENGINE MODEL	SPEC NO.	D.O.M
TVM195	150288G	8150C

Typical Engine I.D. Label

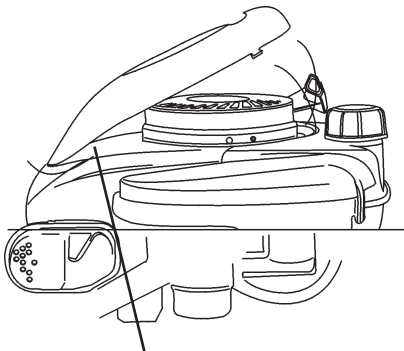

ENGINE MODEL NUMBER LOCATED UNDER COVER

IMPORTANT ENGINE INFORMATION

TECUMSEH POWER COMPANY

THIS ENGINE MEETS 1995-1998 CALIF./US EPA PH1 APPLICABLE EMISSION REGULATIONS FOR ULGE ENGINES FUEL REGULAR UNLEADED OIL SAE 30

ENGINE MODEL	TVM195 150288G	(E)
ENGINE FAMILY	STP318U1G2EA	
DISPLACEMENT	318	D.O.M. (S E R) 8150 C

CAUTION FOR PERSONAL PROTECTION REFER TO OWNER'S MANUAL FOR IMPORTANT SAFETY AND MAINTENANCE INFORMATION



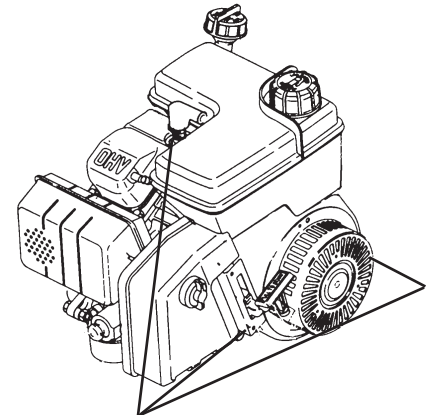

ENGINE MODEL NUMBER LOCATIONS

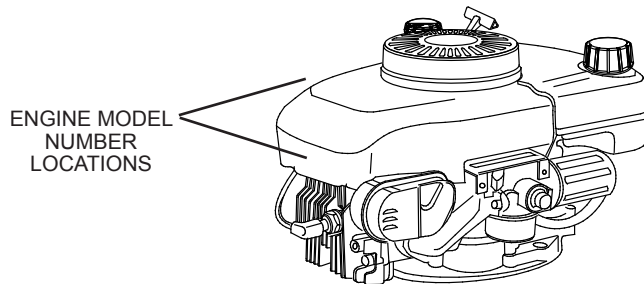

ENGINE MODEL NUMBER LOCATIONS

Model Numbering System for Current Tecumseh's Full Engine Line

Reviewing The Engine ID Label

Effective with the 2004 Model Year, we have changes to the engine I.D. label on our products. The following pages will explain the information contained on the label dependent on the age of your product.

Specification Number

The numbers following the model number make up the specification number.

Using model **LV195EA-361541B**, as an example, interpretation is as follows:

LV195EA-361541B is the model and specification number.

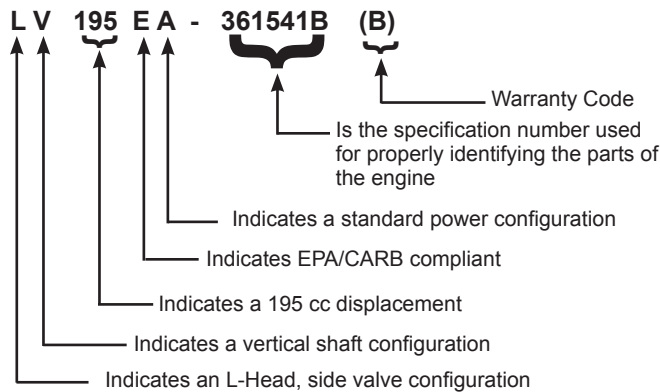

Date of Manufacture

The Date of Manufacture (D.O.M.) indicates the production date.

For this example, **03188BC0010** is the D.O.M. (Date of Manufacture).

Year	Day of Year	Mfg Facility	Assembly Line / Shift	Individual Serial #
2005	188th	B	C	10th unit built
05	188	B	C	0010

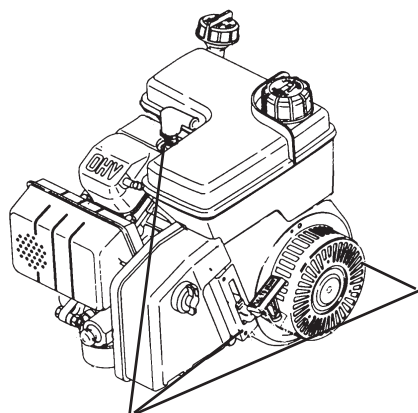

ENGINE MODEL NUMBER LOCATIONS

⚠ WARNING
2083

To avoid injury or death, read the engine operator's manual and the equipment owner's manual. Call 1(800)558-5402 for engine owner's manual.

--- IMPORTANT ENGINE INFORMATION ---

TECUMSEH POWER COMPANY

THIS ENGINE MEETS 1995-2005 CALIF & US EPA PHI APPLICABLE EMISSION REGULATIONS FOR SI SORE ENGINES EM

FUEL: REGULAR UNLEADED OIL: SAE 30

MODEL: LV195EA **WARRANTY:** (B)

SPEC: 361541B **DOM:** 03188BC0010

ENGINE FAMILY: 2TPXS.1951BC DISP: 195 cc

Typical Engine I.D. Label Locations

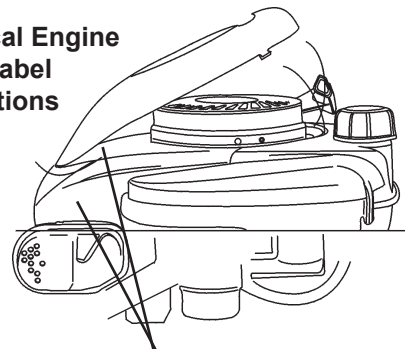

ENGINE MODEL NUMBER LOCATED UNDER COVER

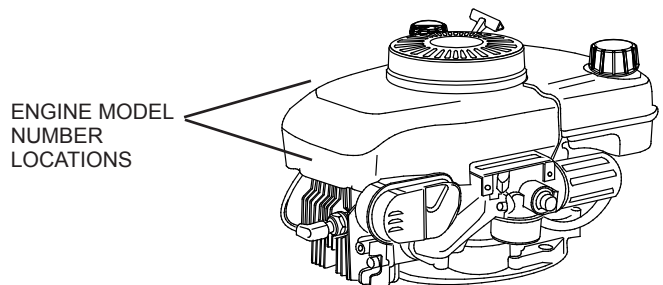

ENGINE MODEL NUMBER LOCATIONS

Model Numbering Identification for Tecumseh's Full Engine Line

CURRENT CODE <i>(effective 2004 production)</i>
1st Space - Valve Orientation
T = Two Cycle
O = Overhead Valve
L = L-Head
2nd Space - Crank Orientation
V = Vertical
H = Horizontal
M = Multi-position
3rd, 4th and 5th Space - Displacement
6th Space - Emissions Class
E = 50 State/Global Emissions Compliant
X = Not for sale in California, except exempt applications
S = Snow Emission Compliant
7th Space - Engine Specifics
A = Standard (OHH50-60), (OHSK50-70)
P = Power Up (OHH65-70, OHSK75-775)

Prior to 2004 Model Number Conversion Chart	
4-Cycle	
LEV90 - LV148EA	OHH60 - OH195EA
LEV120 - LV195EA	OHH65 - OH195EP
HSSK50 - LH195SA	OHSK70 - OH195SA
HSSK55 - LH195SP	OHSK75 - OH195SP
VSK90 - LV148SA	HMSK90 - LH318SA
OHV135 - OV358EA	HMSK110 - LH358SA
OHV180 - OV490EA	OHSK110 - OH318SA
TVT691 - OV691EA	OHSK130 - OH358SA
VTX691 - OV691EP	OHM110 - OH318EA
2-Cycle	
TC300 - TM049XA	
HSK870 - TH139SP	
HSK600 - TH098SA	
AV520 - TV085XA	

4-Cycle

ECH -	Exclusive Craftsman Horizontal
ECV -	Exclusive Craftsman Vertical
H -	Horizontal Shaft
HH -	Horizontal Heavy Duty (Cast Iron)
HHM -	Horizontal Heavy Duty (Cast Iron) (Medium Frame)
HM -	Horizontal Medium Frame
HMSK -	Horizontal Medium Frame (Snow King)
HMXL -	Horizontal Medium Frame (Extra Life)
HS -	Horizontal Small Frame
HSSK -	Horizontal Small Frame (Snow King)
HXL -	Horizontal (Extra Life)
LAV -	Lightweight Aluminum Frame Vertical
LEV -	Low Emissions Vertical
LH -	L-Head Horizontal
LV -	L-Head Vertical
OH -	Overhead Valve Heavy Duty (Cast Iron)
OHH -	Overhead Valve Horizontal
OH195 -	Overhead Valve Horizontal (195 cc's)
OHM -	Overhead Valve Heavy Duty Horizontal (Medium Frame)
OHSK -	Overhead Valve Horizontal (Snow King)
OHV -	Overhead Valve Vertical (Medium Frame)
OV -	Overhead Valve Vertical
OVM -	Overhead Valve Vertical (Medium Frame)

OVRM -	Overhead Valve Vertical (Small Frame) (Rotary Mower)
OVXL -	Overhead Valve Vertical (Medium Frame) (Extra Life)
TNT -	Toro 'N' Tecumseh (Toro Exclusive Series)
TVEM -	Tecumseh Vertical European Model
TVM -	Tecumseh Vertical (Medium Frame) (Replaces V & VM)
TVS -	Tecumseh Vertical Styled
TVT -	Tecumseh Vertical Twin
TVXL -	Tecumseh Vertical (Extra Life)
V -	Vertical Shaft
VH -	Vertical Heavy Duty (Cast Iron)
VLV -	Vector Lightweight Vertical
VLXL -	Vector Lightweight Vertical (Extra Life)
VM -	Vertical Shaft (Medium Frame)
VSK -	Vertical Snow King
VTX -	Vertical Twin

2-Cycle

TH -	Two Cycle Horizontal Shaft
TM -	Two Cycle Multiposition Operation
TV -	Two Cycle Vertical Shaft



Spark Plug Replacement

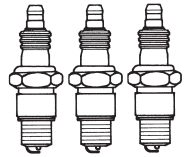

NOTE: Only models which will continue to be manufactured long term will have an updated Model designation.

4-CYCLE SPARK PLUG

Service Number 35395

RJ19LM

ECV100-120
 HMSK70, LH318SA (HMSK80), HMSK90
 HSK30-70
 HSSK40, LH195SA (HSSK50), LH195SP (HSSK55)
 LH358SA (HMSK100), HMSK110
 LEV80, LV148EA (LEV90), LV195EA (LEV120)
 LV148SA (VSK90), VSK100
 TNT100
 TNT120
 TVS75-120
 TVXL90-120

Service Number 34645

RN4C

OH318EA (OHM90-110)
 † OHM120
 OH195EA (OHH60), OH195EP (OHH65)
 OHH/OHSAK40-130
 OH195SA (OHSK70), OH195SP (OHSK75)
 ‡ OH318SA (OHSK110), OH358SA (OHSK120-130)
 OH180
 OV195EA
 OV358EA (OHV110-135), OV490EA (OHV140-180)
 OV691EP (VTX691, TVT691)
 OVM120
 * OVXL120
 * OVXL/C120
 * OVXL125
 OV195

Note:

- * OVXL models with specification nos. below 202700 use RL86C.
- † OHM120 models with specification nos. below 224000 use RL86C.
- ‡ OHSK110 - 130 models with specification nos. below 223000 use RL86C.

Service Number 34046

RL86C

† OHM120
 ‡ OH318SA (OHSK110), OH358SA (OHSK120-130)
 OVM120
 * OVXL120
 * OVXL/C120
 * OVXL125

Note:

- * OVXL models with specification nos. 202700, 203000 and up, use RN4C.
- † OHM120 models with specification nos. 224000 and up, use RN4C.
- ‡ OHSK110, OHSK120-130 models with specification nos. 223000 and up, use RN4C.

Service Number

33636

RJ17LM

H30-80
 HM70-100
 HS40-50
 TVM195-220
 TVXL195-220
 VLV-all

Service Number

35552

RL82C

HH140-160
 OH120-160

Service Number

34277

RJ8C

H22
 H25
 HH40-120
 HHM80
 HMXL70
 HT30
 HT35
 HXL35
 LAV25-50
 TVM125-170
 V40-80
 VH40-100
 VM70-100

NOTE: THE SERVICE NUMBERS LISTED BELOW WILL GIVE CORRESPONDING CHAMPION AND AUTOLITE SUBSTITUTIONS.

	Champion	Autolite
35395	- RJ19LM	NA
35552	- RL82C	4092
34046	- RL86C	425
34645	- RN4C	403
33636	- RJ17LM	245
34277	- RJ8C	304

SPARK PLUG AIR GAP ON ALL MODELS IS .030 (.762 mm)

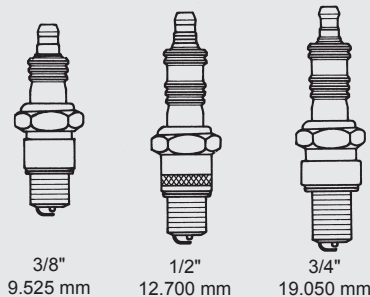

NOTE:

Not all spark plugs have the same heat range or reach. Using an incorrect spark plug can cause severe engine damage or poor performance. Tecumseh uses all three of the reaches shown.

FOR TWO CYCLE INFORMATION REFER TO NEXT PAGE.

Note: If you need assistance locating your engine model numbers please check page 3 or 4.



Spark Plug Replacement

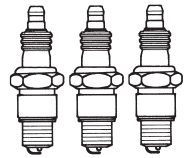

NOTE: Only models which will continue to be manufactured long term will have an updated Model designation.

2-CYCLE SPARK PLUG

Service Number 611100 RCJ6Y TC300 TCH300 TM049XA	Service Number 33636 RJ17LM AV600 AV520 TVS600 TV085XA	Service Number 35395 RJ19LM TVS840 TVXL840	Service Number 611049 RCJ8Y AH520 AH600 HSK840 HXL840 TC200 TCH200 Type 1500 TH098SA	
			HSK600 HSK635 TH139SA HSK845, 850 TH139SP HSK870	

EUROPA MODELS

4-CYCLE SPARK PLUG

Service Number 33636 RJ17LM All Horizontal Models BV BVL BVS Centura Futura HTL		LAV Legend Premier 153/173 Prisma Spectra Synergy Vantage	Service Number 34645 RN4C Centrua OHV Futura OHV			Geotec OHV Premier 45/55	Synergy OHV
			2-CYCLE SPARK PLUG Service Number 33636 RJ17LM AV85/125 AV520/600				
			MV100S TVS600				

NOTE: THE SERVICE NUMBERS LISTED BELOW WILL GIVE CORRESPONDING CHAMPION AND AUTOLITE SUBSTITUTIONS.

	Champion	Autolite
35395	- RJ19LM	NA
33636	- RJ17LM	245
611100	- RCJ-6Y	2974
611049	- RCJ-8Y	2976

SPARK PLUG AIR GAP ON ALL MODELS IS .030 (.762 mm)

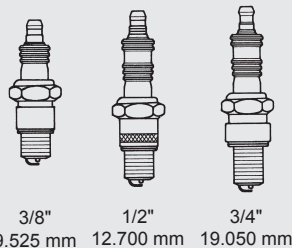

NOTE: Not all spark plugs have the same heat range or reach. Using an incorrect spark plug can cause severe engine damage or poor performance. Tecumseh uses all three of the reaches shown.

Note: If you need assistance locating your engine model numbers please check page 3 or 4.

Fuel Recommendations

Today's fuels have a short shelf life and it is recommended you buy no more than a two week supply at a time.

GASOLINE

Tecumseh Power Company strongly recommends the use of fresh, clean, unleaded regular gasoline in all Tecumseh engines. Unleaded gasoline burns cleaner, extends engine life, and promotes good starting by reducing the build-up of combustion chamber deposits. Leaded gasoline, gasohol containing no more than **10%** ethanol, premium gasoline, or unleaded gasoline containing no more than **15%** MTBE (Methyl Tertiary Butyl Ether), **15%** ETBE (Ethyl Tertiary Butyl Ether) **or 10%** ethanol, can be used if unleaded regular gasoline is not available.

Reformulated gasoline that is now required in several areas of the United States is also acceptable.

NEVER USE gasoline, fuel conditioners, additives or stabilizers containing methanol, gasohol containing more than 10% ethanol, unleaded regular gasoline containing more than 15% MTBE (Methyl Tertiary Butyl Ether), 15% ETBE (Ethyl Tertiary Butyl Ether) or 10% ethanol, gasoline additives, or white gas because engine/fuel system damage could result.

SPECIALTY FUELS

Fuels being marketed for use on small engines can have a significant effect on starting and engine performance. Prior to using any specialty fuel, the Reid Vapor Pressure (RVP) must be determined. Fuels with a rating of less than 50kPa (7psi) should not be used in summer, and fuel with a rating of 85kPa (12psi) should not be used during winter.

SHORT TERM STORAGE

 **WARNING** NEVER store the engine with fuel in the fuel tank inside a building with potential sources of ignition such as hot water and space heaters, clothes dryers, electric motors, etc.

If engine fuel stored in the gas tank and/or an approved gas container is to be unused without gasoline stabilizer for more than 15-30 days, prepare it for short term/seasonal storage.

Tecumseh recommends using **ULTRA-FRESH™** or Fuel Saver Plus Gasoline Stabilizer plus Fuel System Cleaner as an acceptable method of minimizing formation of fuel gum deposits during storage. This product is available from your Authorized Tecumseh Servicing Dealer.

Always follow mix ratio found on stabilizer container. Failure to do so may result in equipment damage.

It is not necessary to drain stabilized gas from carburetor.

FUEL TREATMENT

1. Add fuel stabilizer according to manufacturer's instructions.
2. Run engine at least 10 minutes after adding stabilizer to allow it to reach carburetor.
3. Instead of using a fuel preservative/stabilizer, you can empty the fuel tank as described under "Extended Storage".

Fuel Recommendations - *continued*

EXTENDED STORAGE

NOTES

Clean debris from engine before draining fuel from carburetor. If you have prepared your fuel for short term storage it is not necessary to drain fuel that contains stabilizer from your carburetor.

To avoid severe injury or death, DO NOT pour fuel from engine or siphon fuel by mouth.

1. To prevent serious injury from fuel fires, empty fuel tank by running engine until it stops from lack of fuel. DO NOT attempt to pour fuel from engine.
2. Run the engine while waiting until the remaining fuel is consumed.

NEVER leave the engine unattended when it is running and NEVER run engine in enclosed areas.

FUEL ADDITIVES

Only fuel additives such as Tecumseh's fuel stabilizer Part No. 730245A or liquid varieties can be used when mixed properly. For winter applications, Isopropyl alcohol fuel dryers may be used in the fuel system but must be mixed at the proper ratio recommended by the manufacturer. **NEVER USE METHANOL BASED FUEL DRYERS.**

TECUMSEH 4-CYCLE LUBRICATION REQUIREMENTS

Tecumseh recommends the use of a high quality, brand name oil with a minimum classification of SL/SJ. Very few air cooled engines have any type of oil filtration system, making regular oil changes critical to remove

impurities from the engine and maximize engine life. **Consult the operator's or repair manual for the oil change interval and viscosity based on equipment operating temperature.**

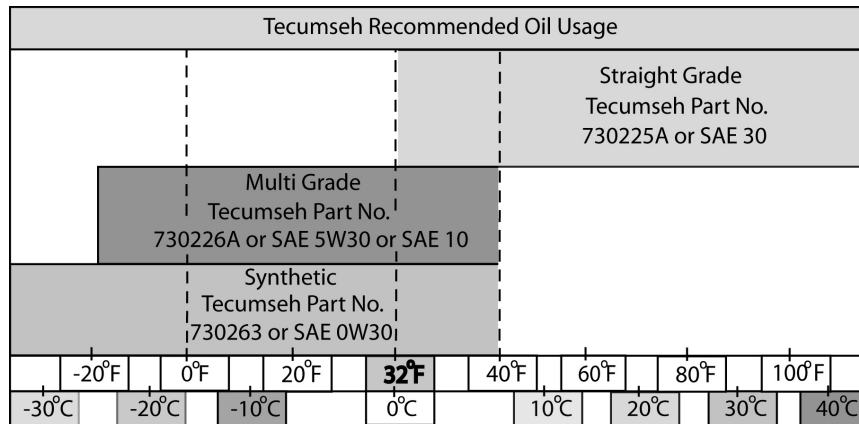

TECUMSEH 4-CYCLE ENGINE OIL

shown with model names prior to 2004

CLASSIFICATIONS: "SL/SJ"

DO NOT USE 10W40

CAPACITIES:

Engine Model	ml	Oz.
All LAV, TVS, LEV, OVRM	630	21
ECV, TNT	630	21
V & VH50-70	810	27
TVM 125, 140	810	27
TVM 170-220	960	32
VM70-100, HHM80	960	32
VH100	1500	50
All VLV	810	27
VSK90-100	630	21
OVM120, OVXL120, 125	960	32
OHV11-13 Without Filter	960	32
OHV11-13 With Filter	1170	39
OHV13.5-17 With Filter	1800	61
OHV13.5-17 Without Filter	1650	55
TVT691 With Filter	2150	71
TVT691 Without Filter	1950	64
H, HSK30-35	630	21
HS, HSSK40-50	630	21
H, HH, HSK50-70	570	19
OHH/OHSK50-70	630	21
HMSK, HM70-100	720	26
OHSK80-100	720	26
OHM120, OHSK110*-130	840	28
HH100,120, OH120-180	1560	52

*NOTE: Model OHSK110 with a spec. of 221000 and up, have a capacity of 26 oz. (720 ml).

TECUMSEH 4-CYCLE ENGINE OIL

shown with model names 2004 production and later

Engine Model	ml	Oz.
LH195SA, LH195SP	630	21
LH318SA, LH358SA	720	26
LV148EA, LV148SA	630	21
LV195EA	630	21
OH195EA, OH195EP	630	21
OH195SA, OH195SP	630	21
OH318EA	720	26
OH358SA	840	28
OV195EA	630	21
OV358EA With Filter	1170	39
OV358EA Without Filter	960	32
OV490EA With Filter	1800	61
OV490EA Without Filter	1650	55
OV691EA With Filter	2150	71
OV691EA Without Filter	1950	64
OV691EP With Filter	2150	71
OV691EP Without Filter	1950	64

EUROPA MODELS *

VERTICALS

	ml	Oz.
Vantage	630	21
Prisma	630	21
Synergy	630	21
Synergy "55"	810	27
Spectra	630	21
Futura	630	21
HTL	630	21
BVS	630	21

HORIZONTALS

BH Series	630	21
Geotec Series 35-50	630	21

NOTE: Vertical shaft engines with auxiliary PTO: 26 oz. (700 ml).

Four Cycle Troubleshooting

The following is provided as a basic troubleshooting guide. Its use requires a complete review of all conditions and symptoms. Always examine the exterior for clues: leaks, excessive dirt, or obvious damage. Some repairs will require the assistance of a Tecumseh Servicing Dealer.

Preparation

Before troubleshooting any system problem, see original equipment manufacturer's (O.E.M.) instructions.

Make your troubleshooting easier by preparing as follows:

- Work in a clean, well-lighted place.
- Keep proper tools and materials nearby.
- Keep an adequate supply of clean petroleum-based solvent.

WARNING To reduce the risk of serious injury or death from fires and/or explosions, NEVER use flammable solvents (e.g., gasoline) to clean serviceable parts. Use a water-based, non-flammable solvent such as Tecumseh Degreaser Cleaner.

CAUTION NEVER use compressed air to clean debris from yourself or your clothing. When using compressed air to clean or dry serviceable parts:

- Wear appropriate eye protection.
- Air pressure must not exceed 30psi (206kPa).
- Use only approved air blow nozzles.
- Shield yourself and bystanders from flying debris.

FUEL SYSTEM

Engine Will Not Start

Check if spark plug is wet or dry

Wet

Dry

Defective spark plug
Use Tester 670366

Restricted air filter

Improper or stale fuel

Exhaust ports plugged

Carburetion problems due to flooding, over priming, etc.*

Ignition System

Review with the customer proper priming procedure (3-5 primes, waiting 2 seconds between each prime)

If equipped with a choke, check for full travel. Check throttle cable and control for proper adjustment.

Check fuel supply and fuel cap vent

Restriction in fuel system (filter)

Carburetion problem* (bad bowl gasket)

Poor Compression

Should more extensive repair be needed, we recommend you contact a local Tecumseh Servicing Dealer for repair. Repair manuals are also available from your local dealer or direct from Tecumseh. A complete list of the available manuals can be found at the end of this book.

NOTE: Refer to Technician's Handbook for a more detailed list of remedies.

Four Cycle Troubleshooting - continued



WARNING

To reduce the risk of serious injury or death from fires and/or explosions, NEVER use flammable solvents (e.g., gasoline) to clean serviceable parts. Use a water-based, non-flammable solvent such as Tecumseh Degreaser Cleaner.

CAUTION

NEVER use compressed air to clean debris from yourself or your clothing. When using compressed air to clean or dry serviceable parts:

- Wear appropriate eye protection.
- Use only approved air blow nozzles.
- Air pressure must not exceed 30psi (206kPa).
- Shield yourself and bystanders from flying debris.

IGNITION SYSTEM

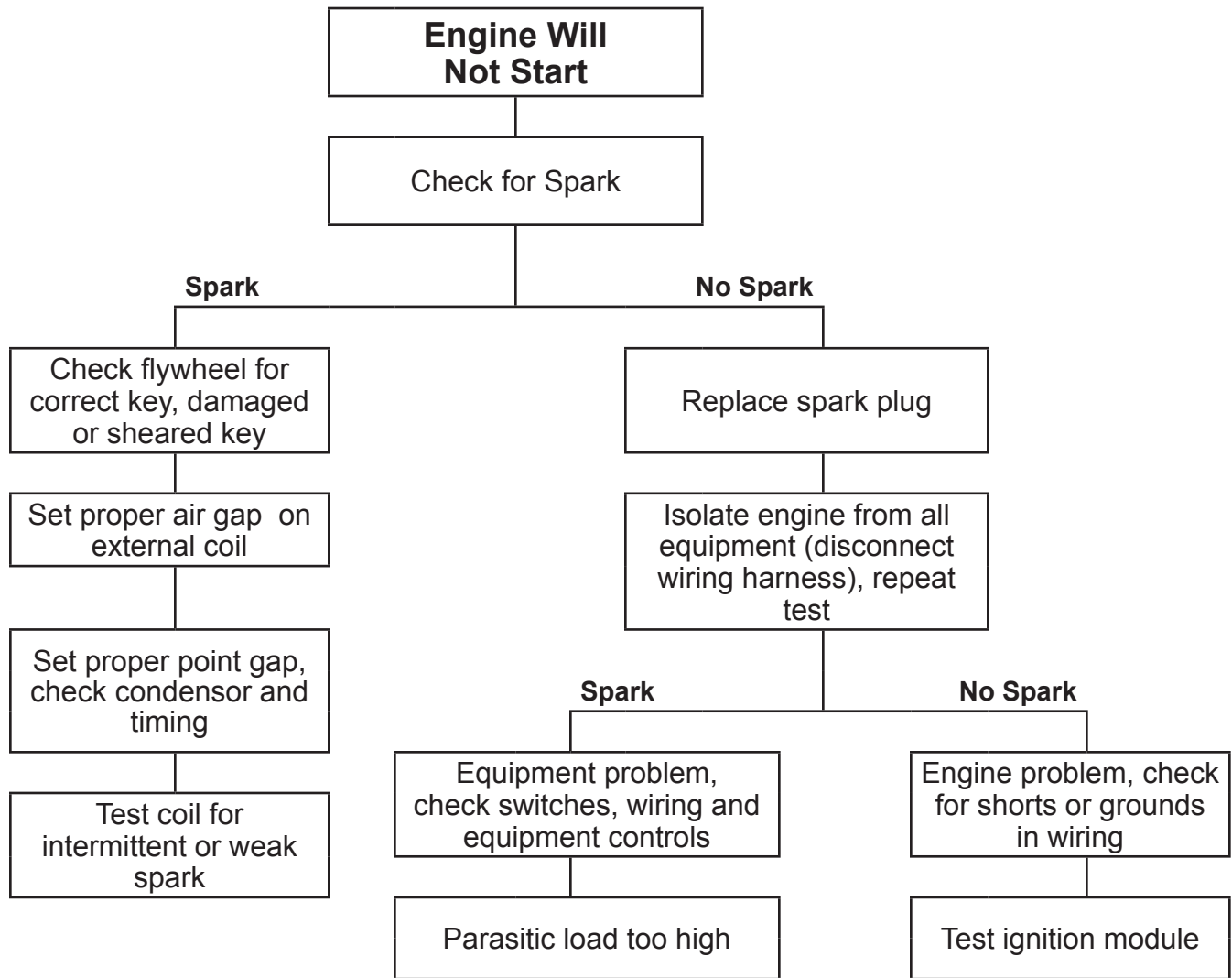

Should more extensive repair be needed, we recommend you contact a local Tecumseh Servicing Dealer for repair. Repair manuals are also available from your local dealer or direct from Tecumseh. A complete list of the available manuals can be found at the end of this book.

NOTE: Refer to Technician's Handbook for a more detailed list of remedies.

TECUMSEH 2-CYCLE ENGINE OIL REQUIREMENTS

The proper type and ratio of 2-cycle oil is critical to long life and low maintenance of the engine. The use of non-certified oils and improper mix ratios can cause severe engine damage and possibly void warranty consideration.

The following is a list of 2-cycle engine oil classifications which are certified for use in Tecumseh 2-cycle engines:

- National Marine Manufacturers Association, (NMMA), TC-WII or TC-W3
- American Petroleum Institute, (API), TC
- Japanese Automobile Standard Organization, (JASO), FB or FC

TWO-CYCLE FUEL/OIL MIX RATIOS		
24:1	32:1	50:1
AV520 Types 670 & 653, TV085 TV085XA (AV600 Type 600-10 & Up) TC200, TCH200, TCH300 TM049XA (TC300) MV100S	TVS600 ALL TYPES AH600	TVS / TVXL HSK840 - 870 - TH139 HSK600 - 635 - TH098

Sears/Craftsman 40:1 2-Cycle Oil has been tested and approved for use in all engines, EXCEPT the TC / TM Models which require a 24:1 Ratio.

2-CYCLE SYNTHETIC BLEND

ENGINE OIL WITH FUEL STABILIZER

PART NO. 730227D

TECUMSEH 2-CYCLE ENGINE OIL may be used in a variety of 2-cycle engines including: outboards, lawnmowers, snow-blower, string trimmers, and edgers at any fuel/oil mixing ratio up to 50:1.

- Superior Lubricity **Extends** engine life by reducing wear
- Longer Spark Plug life through reduced fouling
- Reduces Carbon Build-Up extending required service intervals
- Helps maintain emissions compliance which helps our environment
- Contains Fuel Stabilizer-Extends fuel life and protects fuel system

ENGINE FUEL MIX				
	U.S. Gasoline	U.S. Amount of Oil To Be Added	METRIC Petrol	METRIC Amount of Oil To Be Added
24:1	1 Gallon	5 oz.	4 Liters	167 ml
	2 Gallons	11 oz.	8 Liters	333 ml
	5 Gallons	27 oz.	20 Liters	833 ml
32:1	1 Gallon	4 oz.	4 Liters	125 ml
	2 Gallons	8 oz.	8 Liters	250 ml
	5 Gallons	20 oz.	20 Liters	625 ml
50:1	1 Gallon	2.5 oz.	4 Liters	80 ml
	2 Gallons	5 oz.	8 Liters	160 ml
	5 Gallons	13 oz.	20 Liters	400 ml

Two Cycle Troubleshooting

The following is provided as a basic troubleshooting guide. Its use requires a complete review of all conditions and symptoms. Always examine the exterior for clues: leaks, excessive dirt, or obvious damage. Some repairs will require the assistance of a Tecumseh Servicing Dealer.

Preparation

Before troubleshooting any system problem, see original equipment manufacturer's (O.E.M.) instructions.

Make your troubleshooting easier by preparing as follows:

- Work in a clean, well-lighted place.
- Keep proper tools and materials nearby.
- Keep an adequate supply of clean petroleum-based solvent.

WARNING To reduce the risk of serious injury or death from fires and/or explosions, NEVER use flammable solvents (e.g., gasoline) to clean serviceable parts. Use a water-based, non-flammable solvent such as Tecumseh Degreaser Cleaner.

CAUTION NEVER use compressed air to clean debris from yourself or your clothing. When using compressed air to clean or dry serviceable parts:

- Wear appropriate eye protection.
- Air pressure must not exceed 30psi (206kPa).
- Use only approved air blow nozzles.
- Shield yourself and bystanders from flying debris.

FUEL SYSTEM

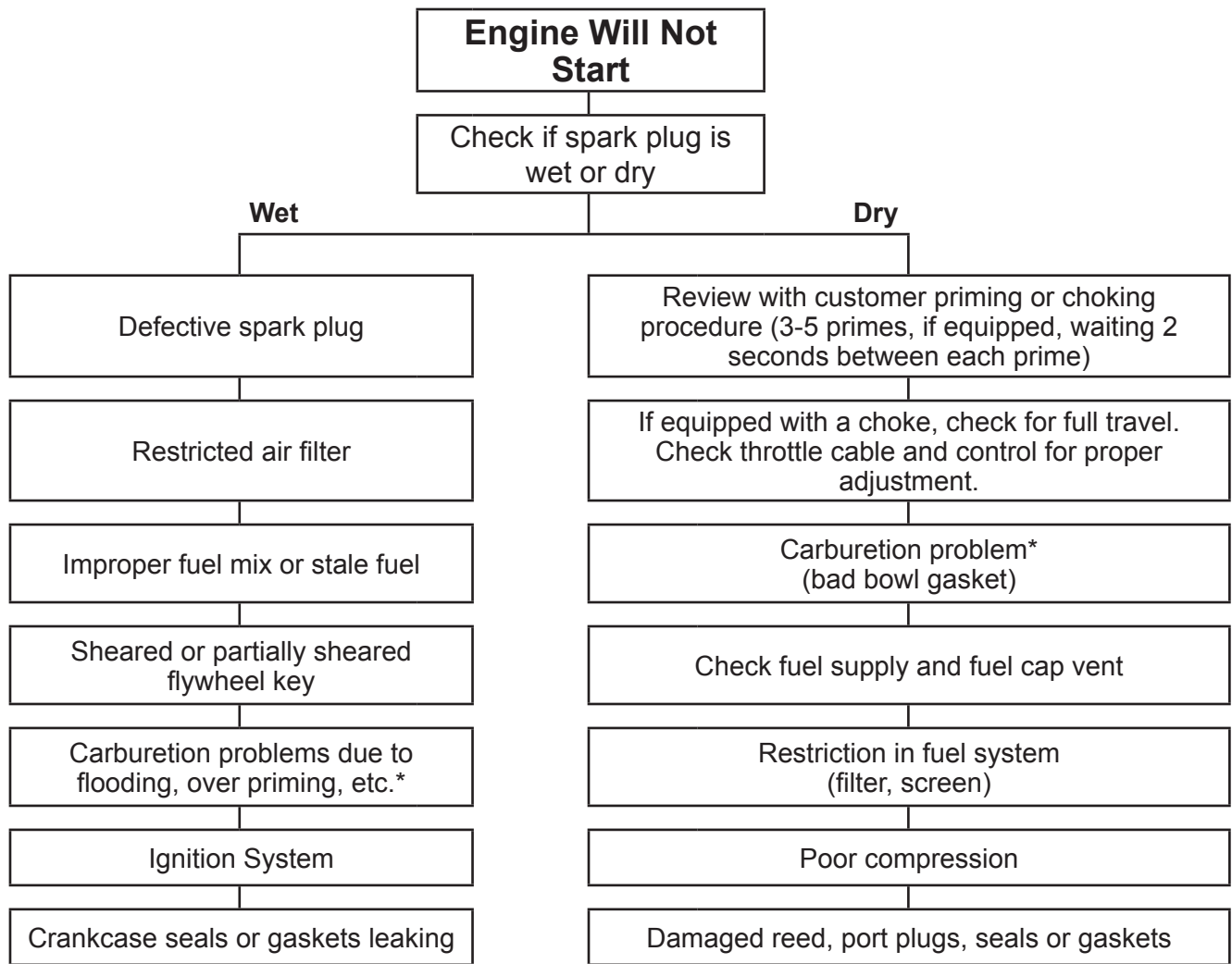

Should more extensive repair be needed, we recommend you contact a local Tecumseh Servicing Dealer for repair. Repair manuals are also available from your local dealer or direct from Tecumseh. A complete list of the available manuals can be found at the end of this book.

NOTE: Refer to Technician's Handbook for a more detailed list of remedies.

Two Cycle Troubleshooting - continued



WARNING

To reduce the risk of serious injury or death from fires and/or explosions, NEVER use flammable solvents (e.g., gasoline) to clean serviceable parts. Use a water-based, non-flammable solvent such as Tecumseh Degreaser Cleaner.

CAUTION

NEVER use compressed air to clean debris from yourself or your clothing. When using compressed air to clean or dry serviceable parts:

- Wear appropriate eye protection.
- Air pressure must not exceed 30psi (206kPa).
- Use only approved air blow nozzles.
- Shield yourself and bystanders from flying debris.

IGNITION SYSTEM

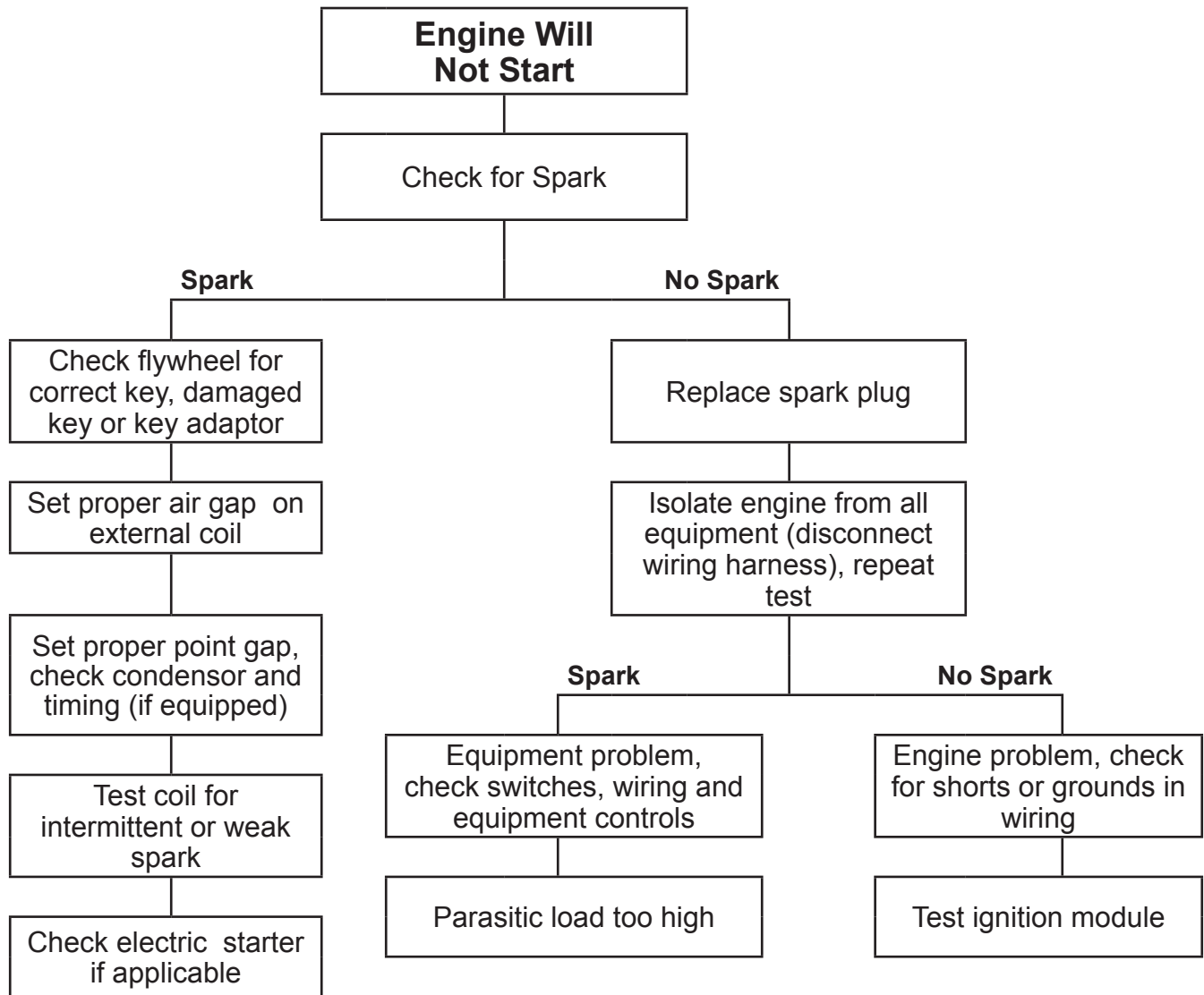

Should more extensive repair be needed, we recommend you contact a local Tecumseh Servicing Dealer for repair. Repair manuals are also available from your local dealer or direct from Tecumseh. A complete list of the available manuals can be found at the end of this book.

NOTE: Refer to Technician's Handbook for a more detailed list of remedies.

Cross Reference for Specification - To - Model Number Designation

This cross reference chart allows you to determine an engine Model Number if you only have the Specification Number.

VERTICAL 4-CYCLE ENGINES

Specification Number Series	Model Number	Specification Number Series	Model Number
10000	TNT100	145000	ECV100
12000	TNT120	147000	ECV105
20000	LAV25, OVRM55	148000	VH80
20500	OVRM105	149000	VH100
21000	OVRM60	150000	V & VM80, TVM195
21800	OVRM60	150200	TVM & TVXL195
22000	OVRM65, OVRM120	150500	TVM195
23000	OV195EA (RM)	151000	ECV110, TVM195
23500	OV195EA (Utility)	151500	TVM220
30000	LAV30	152000	ECV120
33000	TVS75	157000	VM100, TVM220
40000	LAV35	157200	TVM & TVXL220
42000	OVRM905 (Sears Only)	157400	TVM220
42600	OVRM40, OVRM45 (Premier Engine)	200000	OVM120
42900	OVRM40 (High Tech Look)	202000	OVXL120, OVXL125
43000	TVS90	202200	OVXL120 (I/C)
43600	TVS90 (Premier Engine)	202300	OHV11, OHV115
43700	TVS90, TVXL90	202400	OVXL125
43900	TVS90 (High Tech Look)	202500	OHV115
44000	TVS100	202600	OVXL125 (I/C)
44600	TVS100 (Premier Engine)	202700	OHV12, OVXL120 (Tec.1200)
44800	TVS100	203000	OHV125, OVXL125 (Tec1250)
46000	TVS90, TVXL90	203200	OHV13
46600	TVS90	203500	OVXL125 (Tec.1250I/C), OHV13/135
48000	TVS90	203600	OHV14/140
50000	V40	203800	OHV145
50200	LAV40	204000	OHV15/150
52600	OVRM50, OVRM55 (Premier Engine)	204200	OHV16/160
52800	OVRM50, OVRM55	204400	OHV165
52900	OVRM50, OVRM55 (High Tech Look)	204500	OHV155
53000	TVS105	204600	OHV17/170
53600	TVS105 (Premier Engine)	204800	OHV175
53800	TVS105	206000	OHV110
53900	TVS105 (High Tech Look)	206200	OHV115
54000	TVXL105	206400	OHV120
56000	TVS105, TVS & TVXL115	206600	OHV125
56600	TVS105, TVS115 (Premier Engine)	206800	OHV130
56800	TVS115	206900	OHV135,OV358EA (Sm. Enduro)
56900	TVS105, TVS115 (High Tech Look)	208000	OHV180,OV490EA (Lg. Enduro)
57000	TVS & TVXL115	334000	LEV90, LV148EA
57600	TVS115 (Premier Engine)	334500	VSK90, LV148SA
57800	TVS115	335000	LEV100
57900	TVS115 (High Tech Look)	338000	LEV100
60000	V50, TVM125	338500	VSK100
61000	TVS & TVXL115	340000	LEV100
61600	TVS & TVXL115	345000	LEV100
61800	TVS115	346000	LEV105
61900	TVS115	347000	LEV105
62000	LAV50	348500	VSK105
62100	LAV50 & TVS115	350000	LEV115
63000	TVS120	355000	LEV115
63200	TVS120, TVEM120	360000	LEV115
63600	TVS120 (Premier Engine)	361000	LEV120
63900	TVS120 (High Tech Look)	361400	VSK120
66000	TVS120	361500	LEV120, LV195EA (Utility)
66100	TVS120	362000	LEV120, LV195EA (RM)
70000	V60, TVM140	400000	VLV40
80000	VH40	500000	ULT, VLV B24, VLXL50, & VLV126
90000	VH50	501000	ULT, VLV, VLXL55, & VLV126
100000	VH60	502000	ULT, VLV60, VLV65, & VLV126
125000	V70	502500	VLV65, VLV66
127000	VM70, TVM170	600400	TVT691
127200	TVXL170	600800	TVT691, OV691EA (Twin)
135000	VH70	600900	VTX691, OV691EP (Twin)

Cross Reference for Specification - To - Model Number Designation

This cross reference chart allows you to determine an engine Model Number if you only have the Specification Number.

HORIZONTAL 4-CYCLE ENGINES

Specification Number Series	Model Number	Specification Number Series	Model Number
15000	H22	120000	HH120
25000	H25	130000	H70
26000	OHH45	130200	HSK70
35000	H30	132000	HM & HMSK70
35400	HSK30	132500	HMXL70
35800	H30	140000	HH70
36700	H30	146000	ECH90
45000	H & HT35	155000	H & HM80
45400	HSK35	155000	HMSK80
45800	H35	155800	HM85
46700	H35	155900	HM & HMSK85
47000	HXL35	156000	HM90
55000	H40	156500	HMSK90, LH318SA
55200	HS & HSSK40	159000	HM & HMSK100, LH358SA
55500	HSK40	159900	HMSK105
55700	H40	159950	HMSK110
55800	H40	160000	HH & OH140
55900	HSSK40	170000	HH150 & 160
65000	H50	170000	OH160
65300	HSK50	175000	OH120
67000	HS & HSSK50, LH195SA	180000	OH180
67500	HSSK55, LH195SP	190000	HHM80
68000	OHH50	220000	OHM120
68500	OHSK50	221000	OHSK110
69000	OHH55	221200	OHSK80
69500	OHSK55	221400	OHSK90
71100	OHH60, OH195EA	221600	OHSK100
71500	OHSK60	221700	OHSK110
71700	OHH65	221800	OHSK115, OH318SA (Premium)
71800	OHH65, OH195EP	222000	OHSK120
71900	OHSK65	222300	OHM90
72000	OHH70	222500	OHM100
72500	OHSK70, OH195SA (Premium)	222700	OHM110, OH318EA
73500	OHSK75, OH195SP (Premium)	223000	OHSK90
75000	H60	223400	OHSK110
76000	HSK60	223600	OHSK120
85000	HH40	223700	OHSK125
95000	HH50	223800	OHSK130, OH358SA (Premium)
105000	HH60		
110000	HH80		
115000	HH100		

VERTICAL 2-CYCLE ENGINES

Specification Number Series	Model Number
3600	TC300, TM049XA
670000	AV520, TV085XA

HORIZONTAL 2-CYCLE ENGINES

Specification Number Series	Model Number
1720	HSK635, TH098SA
8300	HSK850, TH139SA
8700	HSK870, TH139SP

TECUMSEH AND PEERLESS® MODEL AND SPECIFICATION NUMBERS

The following information is being provided to assist you in locating and recording your Tecumseh transmission components model and specification numbers. This information will be needed to use this book or obtain parts from a local Tecumseh dealer.

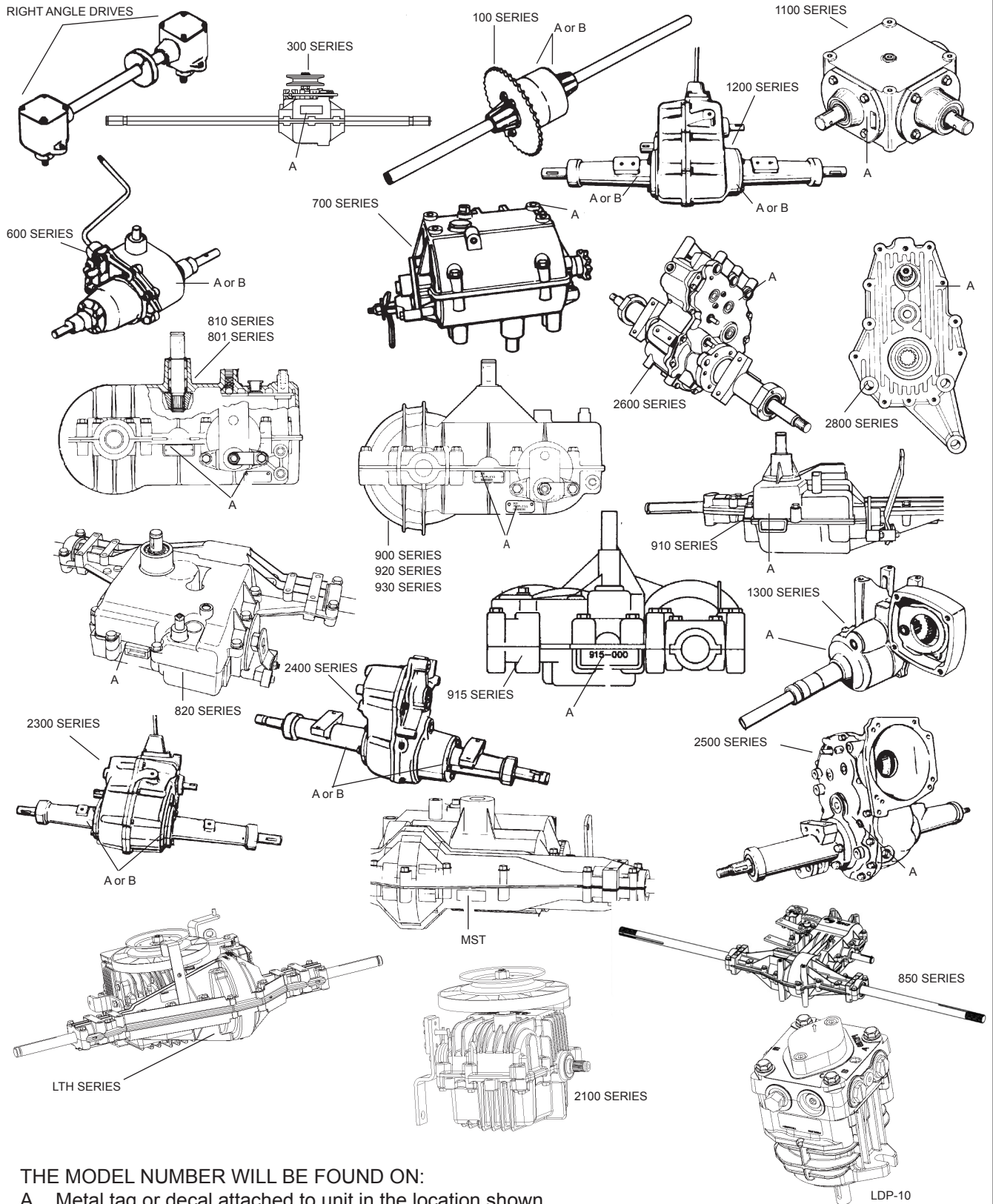

THE MODEL NUMBER WILL BE FOUND ON:

- A. Metal tag or decal attached to unit in the location shown.
- B. Stamped on unit in the location shown.

Various Styles of Identification Used On Tecumseh and Peerless Transmission, Transaxle and Gear Products



Individual Serial Number
 Manufactured on the 275th Day
 Manufactured in 1991

MODEL NUMBER REQUIRED FOR WARRANTY SPECIFICATION NUMBER REQUIRED FOR WARRANTY

PEERLESS **205 - 027C** TECUMSEH



205 - 027C8194A0048

D.O.M. (DATE OF MANUFACTURE)
 ORIGINAL SERIAL NUMBER

MODEL NUMBER REQUIRED FOR WARRANTY SPECIFICATION NUMBER REQUIRED FOR WARRANTY

PEERLESS **MST - 206 - 502A** TECUMSEH



6304A00013

D.O.M. (DATE OF MANUFACTURE)
 ORIGINAL SERIAL NUMBER

MODEL NUMBER REQUIRED FOR WARRANTY SPECIFICATION NUMBER REQUIRED FOR WARRANTY

PEERLESS **VST - 205 - 020C** TECUMSEH



D.O.M. 7070A - 0005

D.O.M. (DATE OF MANUFACTURE)
 ORIGINAL SERIAL NUMBER

Early Models were not identified with a model number on the unit.

Basic Gear Drive Troubleshooting

Preparation

NOTE

Before troubleshooting any system problem, see original equipment manufacturer's (O.E.M.) instructions.

Make your troubleshooting easier by preparing as follows:

- Work in a clean, well-lighted place.
- Keep proper tools and materials nearby.
- Keep an adequate supply of clean petroleum-based solvent.

To avoid carbon monoxide poisoning, make sure engine is outdoors in a well-ventilated area.



WARNING

Some maintenance procedures can not be performed until the vehicle wheels are secured and off the ground. Failure to do so could result in death or serious injury to yourself and/or bystanders.



WARNING

DO NOT attempt any maintenance procedures with the engine running. Doing so could result in death or serious injury to yourself and/or bystanders.



WARNING

Use care when performing inspection of the drive belt assembly including all vehicle linkage. Failure to do so could result in death or serious injury to yourself and/or bystanders.

Hard Shifting Transaxles and Drive Belts

Often hard shifting is blamed on an internal problem in the transaxle.

To determine if the problem is transaxle or equipment related make these simple checks.

1. Turn the unit off so that all power is removed to the transaxle.
2. With the unit off, move the shift lever through the shift gate. Movement of the lever should have only slight resistance. The shifting effort should be equal when the engine is off and when running. If the unit is difficult to shift the problem would be internal and the transaxle would need to be removed and repaired.
3. If the unit shifts with ease, check the following areas that would be equipment related. Check to see if the belt is releasing from the pulley on the engine and transmission / transaxle, it may require that the belt guides be repositioned. The distance required from the pulley to the guide is typically 1/16" to 3/16" (1.6 mm - 4.8 mm), always check the O.E.M. specs.
4. Check to see if the pulley is damaged and may not be releasing the belt.
5. Confirm the correct length and type of belt, as recommended by the manufacturer, is installed.

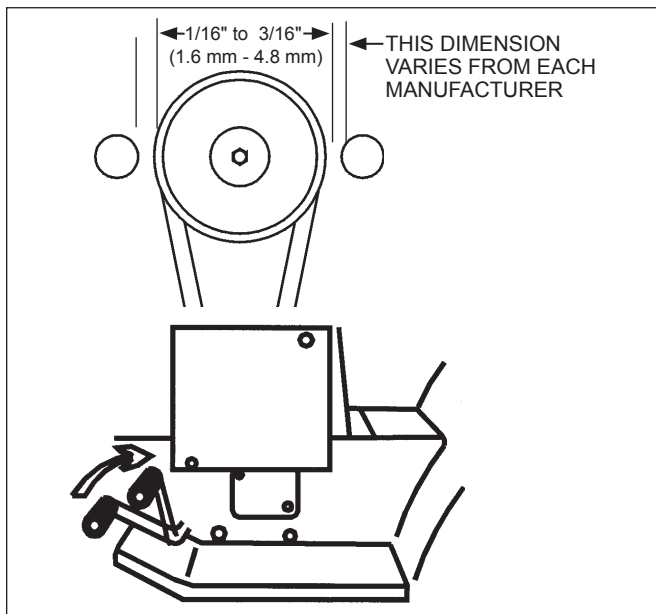

For proper declutching to occur, it is very important that the engine belt guide be set at a predetermined clearance when engaged (set by the manufacturer) and away from the belt with the belt engaged.

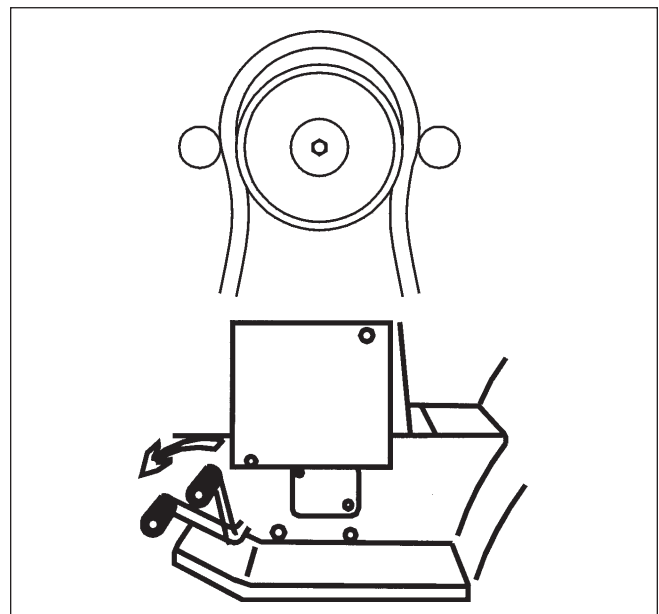

With clutch disengaged, it is very important that the belt blossoms away from the engine pulley. Belt must stop turning before transaxle shifting can occur.

Improper belt or belt guide clearance will not allow the belt to disengage, causing internal transmission damage.

Basic Gear Drive Troubleshooting - *continued*

6. Check the brake/clutch pedal to make sure that when the pedal is depressed that the idler pulley is releasing the belt tension before it applies the brake. If this does not happen the unit will still be under a load and be impossible to shift.
7. The final area to check would be for damaged or binding shift linkage.

Hard shifting with the engine off could be caused by:

1. Shift linkage out of adjustment.
2. Corrosion in the transaxle or transmission.
3. Damaged shift keys, gears, or shifter brake shaft.
4. Belt guides missing or improperly adjusted (see equipment manufacturer specs).

Unit seems to slip:

1. Check for proper belt adjustment (consult O.E.M. operator's manual).
2. Check for proper clutch/brake adjustment (consult O.E.M. operator's manual).
3. Check pulley condition and wheels for sheared or damaged keys.
4. Check drive belt condition, if glazed or worn, replace it.
5. Possible internal transmission damage. We suggest you contact a local Tecumseh Servicing Dealer.

Tecumseh and Peerless Transmission, Transaxle and Gear Products

NOTE

Before troubleshooting any system problem, see original equipment manufacturer's (O.E.M.) instructions.

Make your troubleshooting easier by preparing as follows:

- Work in a clean, well-lighted place.
- Keep proper tools and materials nearby.
- Keep an adequate supply of clean petroleum-based solvent.

To avoid carbon monoxide poisoning, make sure engine is outdoors in a well-ventilated area.

WARNING Some maintenance procedures can not be performed until the vehicle wheels are secured and off the ground. Failure to do so could result in death or serious injury to yourself and/or bystanders.

WARNING **DO NOT** attempt any maintenance procedures with the engine running. Doing so could result in death or serious injury to yourself and/or bystanders.

WARNING Use care when performing inspection of the drive belt assembly including all vehicle linkage. Failure to do so could result in death or serious injury to yourself and/or bystanders.

LTH-2000 Series Troubleshooting Chart

Tecumseh's lawn tractor hydrostatic transaxle (LTH) includes a hydrostatic transmission attached to a final drive. Use of this troubleshooting chart will aid in determining the source of a problem; the hydrostatic transmission, final drive or vehicle's belt drive and/or linkage systems.

Tecumseh LTH-2000 Series Hydrostatic Transaxle Troubleshooting

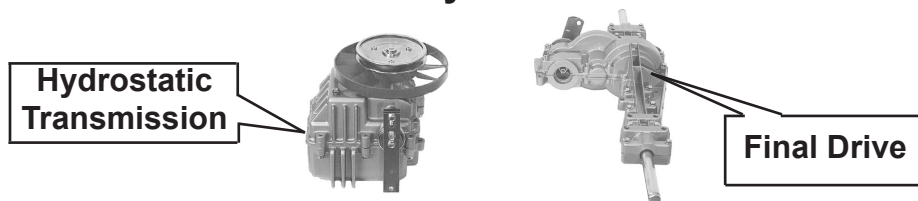

SYMPTOM	PROBLEM	CORRECTIVE ACTION
REDUCED POWER	Improper belt tension	Belt worn, replace
	Belt worn, glazed, or oil saturated	Replace belt
	Drive pulley worn	Replace pulley and belt (See O.E.M. equipment manual)
	Brake set too tight	Set brake adjustment (See O.E.M. equipment manual)
	Shifter linkage misadjusted or broken	Linkage damaged or loose, replace or adjust (See O.E.M. equipment manual)
	Fluid low in hydrostatic transmission	Check and add fluid if low (Part No. 730228A)
	Hydrostatic transmission bad	Replace hydrostatic transmission
DIFFICULT TO SHIFT	Linkage broken or bent	Repair or replace linkage (See O.E.M. equipment manual)
	Hydrostatic transmission pump seized	Replace hydrostatic transmission
	Hydrostatic transmission control friction pack misadjusted	Replace friction pack washers, tighten nut to 100 in. lbs. (11.2 Nm) loosen nut 4-turns

Tecumseh LTH-2000 Series Transaxle Troubleshooting - continued

SYMPTOM	PROBLEM	CORRECTIVE ACTION
UNIT IS NOISY	Final drive gear noise	Check, add gear oil to final drive Check, replace worn gears Check, replace worn bearings
	Hydrostatic transmission noise	Replace hydrostatic transmission
	Transaxle clicking	Mechanical disconnect not properly engaged, check for obstruction Check, replace mechanical disconnect components (If hydrostatic transmission shaft is damaged, replace transmission)
DOES NOT DRIVE	Improper belt tension	Belt worn, replace (See O.E.M. equipment manual)
	Brake setting incorrect	Adjust brake to proper setting (See O.E.M. equipment manual)
	Belt worn, glazed, or oil saturated	Replace belt (See O.E.M. equipment manual)
	Drive pulley worn	Replace pulley and belt (See O.E.M. equipment manual)
	Transaxle - hydrostatic transmission bad	Replace hydrostatic transmission
	Shifter linkage misadjusted or broken	Linkage damaged or loose, replace or adjust (See O.E.M. equipment manual)
	Fluid low in hydrostatic transmission	Check and add fluid if low (Part No. 730228A)
	Disconnect is in freewheel position	Move control to connected position (See O.E.M. equipment manual)
	Sheared or missing axle key	Replace missing or broken key
	Damaged or broken final drive gear	Check, replace worn or damaged gear
	Hydrostatic transmission leaking	Replace hydrostatic transmission
LEAKING LUBRICANT	Hydrostatic transmission leaking	Replace hydrostatic transmission
	Final drive leaking at seam	Split final drive housing, clean old sealant off, replace seals, apply new sealant (torque bolts 80-120 in. lbs.[9.0 Nm - 13.5 Nm])
	Final drive leaking at shaft seal	Split final drive housing, clean old sealant off, replace seals, apply new sealant (torque bolts 80-120 in. lbs. [9.0 Nm - 13.5 Nm])
BRAKE NOT WORKING	Linkage out of adjustment	Adjust brake linkage (See O.E.M. equipment manual)
	Linkage bent or broken	Replace components, set brake (See O.E.M. equipment manual)
	Brake setting incorrect	Adjust brake to proper setting (See O.E.M. equipment manual)

1800 / VST Troubleshooting

The information on this page has been provided to help understand the internal operation of the VST. Do not use this information to attempt any internal repairs.

Tecumseh's current policy on hydrostatic transaxles that have internal failures is to replace the complete unit. This has not changed. However, Tecumseh would like to provide a failure checklist to assist in making an accurate evaluation of the complete tractor to eliminate any unnecessary replacements. Here is a list of items to check and corrective actions to take.

To properly test the unit for power loss.

1. Allow the unit to cool before trying the following steps.
2. Put the shift lever in a position that is 1/2 of the travel distance from neutral to forward.
3. Place the tractor on a 17° grade.
4. Drive the tractor up the grade (without the mower deck engaged). The loss of power experienced should be approximately 20%. This is considered normal. If the loss of power is approximately 50%, this would be considered excessive.
5. Bring the unit to neutral, shift into forward and note the response. Care should be taken to move the lever slowly to avoid an abrupt wheel lift.

To determine if the problem is with the hydro unit, all external problem possibilities must be eliminated. Here are some potential problem areas.

1. **Overheating:** Heat can cause a breakdown in the viscosity of the oil which reduces the pressure used to move the motor. Remove any grass, debris, or dirt buildup on the transaxle cover and / or between the cooling fins and fan. Buildup of material will reduce the cooling efficiency.
2. **Belt slippage:** A belt that is worn, stretched, or the wrong belt (too large or wide) can cause belt slippage. This condition may have the same loss of power symptom as overheating. Typically, the unit which has a slipping belt will exhibit a pulsating type motion of the mower. This can be verified visually by watching the belt and pulley relationship. If the belt is slipping, the belt will chatter or jump on the pulley. If the belt is good, a smooth rotation will be seen. Replace the belt and inspect the pulley for damage.

3. **Leakage:** The VST and 1800 Series have two oil reservoirs which can be checked for diagnostic purposes. The first is the pump and motor expansion bellows. With a small diameter blunt or round nose probe, check the bellows depth through the center vent hole. Proper depth from the edge of that hole is 3-1/4 - 3-1/2 inches (8.25 - 8.9 cm).

The second chamber is for the output gears including the differential. FIRST make sure the tractor is level, then remove the drain/fill plug. NOTE: Some units that do not have differential disconnect will have two plugs. We recommend using only the primary plug. With a small pocket rule insert until you touch bottom of case. You can then remove it and check for 1/4 - 3/8 inches (6.5 - 9.5 mm) contact, this is full at its 8 oz. capacity.

4. **Low ground speed:** If the linkage is not synchronized to absolute neutral, or the shift lever is not properly fastened to the tapered control shaft, full forward travel may not be achieved. This may cause a false reading and be misdiagnosed as a low power condition. This also could be caused by the brake not releasing.

To determine absolute neutral, the hole in the tapered control shaft must face straight up and down, at this point make sure the O.E.M. linkage is in neutral. To properly fasten the control lever to the shaft, torque the nut to 25-35 ft. lbs. (34 - 48.3 Nm) of torque with the shaft and the lever in neutral.

When attaching the shifter arm to the shaft you must prevent any rotation during torquing. This can be done by placing a long 5/16" bolt in the hole of the shaft. Hold the bolt until the tapers are locked and the nut torque is correct.

To make sure that the brake is not binding, drive the unit up a slight grade. Position the speed control lever into neutral. The unit should coast backwards. If the unit does not coast back slowly, the brake is not released from the brake disk. Adjust the brake linkage to release the brake completely when the foot pedal is released.

5. **Hard to shift:** Typically hard to shift symptoms are not caused by the hydrostatic unit. The shift arm should move with relative ease. Approximately 40-50 in. lbs. (4.48 - 5.6 Nm) at the transaxle for foot pedal units or 150-200 in. lbs. (16.8 -22.4 Nm) for hand operated units. This varies depending on the type of linkage. Binding may occur in the linkage connections due to rust or moisture. Lubricating these connections and checking for bent or damaged parts should resolve hard shifting.

Tecumseh and Peerless® Lubrication Requirements

NOTE

Use **ONLY** the recommended lubricant in all models as listed to insure proper operation and long life.

another free manual from www.searstractormanuals.com

TRANSAXLES		TRANSMISSION		RIGHT ANGLE AND T-DRIVES					
Model No.	Quantity	Model No.	Quantity	Model No.	Quantity				
301	Non-Serviceable	2500	†	All Models Except *	4 oz./118 ml Grease				
600	24 oz./710 ml Oil	2600	†	*1408-P91	3 oz./89 ml Grease				
800	30 oz./887 ml Grease	700	12 oz./355 ml Grease	*1409-P91					
801	36 oz./1065 ml Grease	700H	12 oz./355 ml Grease	*1410-P91					
820	36 oz./1065 ml Grease	2800	†	*3002					
900	26 oz./769 ml Grease	HYDROSTATIC TRANSAXLES and TRANSMISSIONS		*3003					
910	18 oz./532 ml Grease			1800 Series		Limited service; use Kit Part No. 799030	*3028		
915	10 oz./296 ml Grease	VST205/705	Limited service; use Kit Part No. 799030	*3029					
920	30 oz./887 ml Grease	LTH 2000	Limited service; final drive ONLY 8 oz./240 ml Oil	*3035					
930	30 oz./887 ml Grease	2100	Non-Serviceable	1000 Series	6 oz./180 ml Oil †††				
1200	48 oz./1420 ml Oil ††	LDP-10	Non-Serviceable	1100	16 oz./473 ml Oil				
1301	44 oz./1301 ml Oil	DIFFERENTIALS							
1305		TWO SPEED AXLE							
1309		THREE SPEED AXLE							
1313		All Models	3 oz./89 ml Grease						
1302		<p>Grease: Bentonite Grease Part Number 788067C</p> <p>Oil: SAE E.P. 80W90 Oil Part Number 730229B</p> <p>† Refer to O.E.M. Technician's Manual for type of lubricant.</p> <p>†† To be filled through shift lever opening.</p> <p>††† Some 1000 Right Angle and T-Drives use Bentonite Grease.</p> <p>†††† Tecumseh's current policy on VST and 1800 Series transaxles with internal failure, is to replace the complete unit. VST and 1800's have two separate reservoirs which can be checked for diagnostic purpose only. The output gear reservoir can be checked with a small pocket rule as outlined in the Tecumseh & Peerless Transmission and Drive Products Handbook.</p> <p>Refer to Tecumseh & Peerless Transmission and Drive Products Handbook, 691218.</p>							
1303									
1304									
1306									
1307									
1308									
1310									
1311									
1312									
1314									
1315									
1316									
1317									
1318									
1319									
1320									
1321									
1322									
1325									
1328									
1329									
1323	24 oz./710 ml Oil								
1326									
1327									
MST200	16 oz./473 ml Oil								
VST205 and 1800's	††††								
2300	64 oz./1892 ml Oil								
2400	32 oz./946 ml Oil								



Repair Manuals

Service Number 740043 or 695244A

- † OHM120
- ‡ OH318SA (OHSK110), OH358SA (OHSK120-130)
OH318EA (OHM90-110)
- † OHM120
OH195EA (OHH60), OH195EP (OHH65)
OHH/OHSK40-130
OH195SA (OHSK70), OH195SP (OHSK75)
- ‡ OH318SA (OHSK110), OH358SA (OHSK120-130)
OVM120
- * OVXL120,
* OVXL/C120
* OVXL125
OV195EA
OV358EA (OHV110-135)
OV490EA (OHV140-180)
OV691EP (VTX691, TVT691)
OVM120
- * OVXL120
* OVXL/C120
* OVXL125

Service Number 691462A

- HH140-160
- OH120-180

Service Number 740047 or 692508

- AH520
- AH600
- HSK840
- HXL840
- TC200
- TCH200 Type 1500
- TH098SA (HSK600), HSK635
- TH139SA (HSK845, 850)
- TH139SP (HSK870)
- AV600
- TV085XA (AV520)
- TVS600

Service Number 694988

- TVS840
- TVXL840

Service Number 694782

- TCH300
- TM049XA (TC300)

Service Number 740049 or 692509

- ECV100-120
- HMSK70, LH318SA (HMSK80), HMSK90,
H22
H25
H30-80
HM70-100
HH40-120
HHM80
HMXL70
HT30
HT35
HXL35
HS40-50
HSK30-70
HSSK40, LH195SA (HSSK50), LH195SP (HSSK55)
LH358SA (HMSK100), HMSK110
LAV25-50
LEV80, LV148EA (LEV90), LV195EA (LEV120)
LV148SA (VSK90), VSK100
TNT100
TNT120
TVS75-120
TVXL90-120
TVM125-170
TVM195-220
TVXL195-220
V40-80
VH40-100
VM70-100
VLV-ALL

Service Number 740045 or 691218

- 100 Series Differentials
- MST200 Series Transaxles
- 300 Series Transaxles
- 600 Series Transaxles
- 601 Slow Speed Transaxle
- 700 Series Transmissions
- 700H Series Transmissions
- 800/801 Series Transaxle
- 820 Series Transmission
- 900 Series Transaxles
- 910 Series Transaxles
- 915/940 Series Transaxles
- 920 Series Transaxles
- 930 Series Transaxles
- 1000/1100 Series Right Angle / T-Drives
- 1200 Series Transaxles
- 1300 Series Transaxles
- 2300 Series Transaxles
- 2400 Series Transaxles
- 2500 Series Transaxles
- 2600 Series Transaxles
- VST Transaxles



ENGINES & TRANSMISSIONS

TECUMSEH POWER COMPANY

900 North Street
Grafton, Wisconsin 53024

1-800-558-5402