

**ROPER**

**TRACTOR AND ACCESSORIES  
FOR 1980**

**ridin' high**



another free manual from [www.searstractormanuals.com](http://www.searstractormanuals.com)

another free manual from [www.searstractormanuals.com](http://www.searstractormanuals.com)

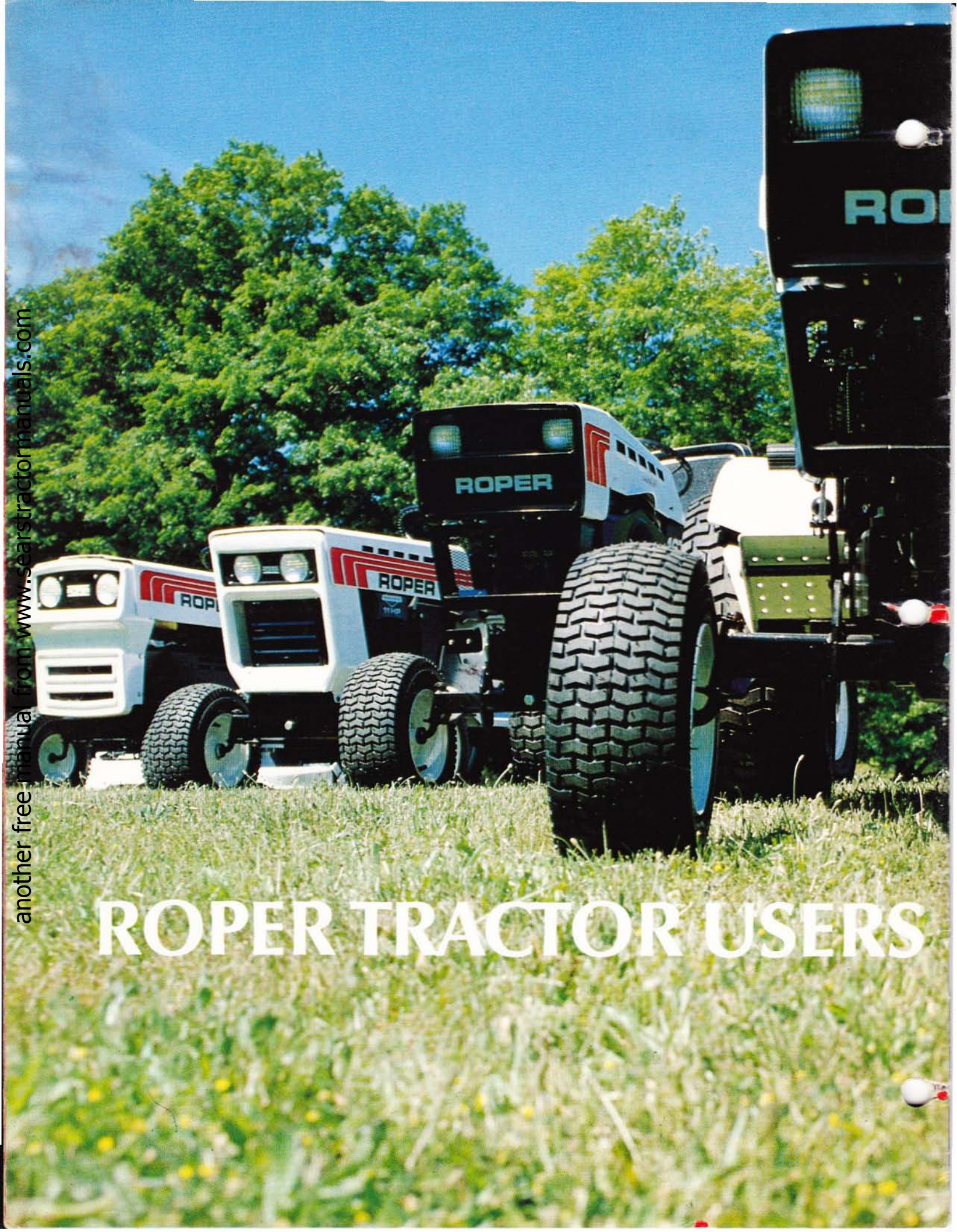

# ROPER TRACTOR USERS

another free manual from [www.seartractormanuals.com](http://www.seartractormanuals.com)

ACROSS CANADA ARE...

**ridin' high**

MODEL L8218 CT	
ENGINE	BRIGGS & STRATTON
HORSEPOWER	8
DISPLACEMENT	19.4
IGNITION SYSTEM	KEY
CYLINDERS	1
FUEL TANK (CAPACITY)	4-3/4 QTS
TRANSMISSION	4 SPEED TRANSAXLE
BATTERY	24 AMPS
FRONT TIRES	15. x 6.0
REAR TIRES	18. x 9.5
LENGTH	63"
WIDTH	48"
WEIGHT (APPROX)	354 lbs



## Smooth and easy lawn tractors **MODEL L8218 CT—8 HP**

Ample power and smooth handling puts lawn work behind you. Positive geared steering gives you precise control in tight places. Powered with an 8 horsepower Briggs & Stratton engine and transaxle drive with 3 forward speeds plus reverse. Cuts cleanly with a 36" dual blade mower with five cutting height adjustments. Standard features include electric starter, headlights, tail reflector, separate throttle/choke, 13" steering wheel, combination clutch/brake, separate parking brake, spring mounted seat and neutral interlock safety system.

Tire Size: Front 15.0" x 6.0"  
Rear 18.0" x 9.5"

Wheel Base: 43.5"  
Overall Length: 63"  
Overall Width: 48" (with deflector)  
Overall Height: 40"  
Shipping Weight: 354 lbs.

### SPEED RANGE (APPROX. MPH)

FIRST	2.0
SECOND	3.8
THIRD	5.7
REVERSE	2.7

MODEL L1219 AT	
ENGINE	BRIGGS & STRATTON
HORSEPOWER	11
DISPLACEMENT	23.7
IGNITION SYSTEM	KEY
CYLINDERS	1
FUEL TANK (CAPACITY)	4-3/4 QTS
TRANSMISSION	4 SPEED TRANSAXLE
BATTERY	24 AMPS
FRONT TIRES	15.0 x 6.0
REAR TIRES	18. x 9.5
LENGTH	63"
WIDTH	48"
WEIGHT (APPROX)	394 lbs



## The great going lawn tractor **MODEL L1219 AT — 11 HP**

Plenty of power, tight turn manoeuvrability puts you ahead with Roper positive geared steering. Powerful 11 horsepower Briggs & Stratton engine and transaxle drive with 3 forward speeds plus reverse. Complete with 36" dual blade mower with five adjustments for cutting height. Standard features include electric starter, headlights, tail reflector, separate throttle/choke, 13" steering wheel, combination clutch/brake, separate parking brake, spring mounted seat and neutral interlock safety system.

Tire Size: Front 15.0" x 6.0"  
Rear 18.0" x 9.5"  
Wheel Base: 43.5"  
Overall Length: 63"  
Overall Width: 48" (with deflector)  
Overall Height: 40"  
Shipping Weight: 394 lbs.

### SPEED RANGE (APPROX. MPH)

FIRST	2.0
SECOND	3.8
THIRD	5.7
REVERSE	2.7

	MODEL T1228 BT
ENGINE	BRIGGS & STRATTON
HORSEPOWER	11
DISPLACEMENT	24.36
IGNITION SYSTEM	AUTOMOTIVE TYPE
CYLINDERS	ALUMINUM ALLOY
FUEL TANK (CAPACITY)	1-3/4 GAL
TRANSMISSION	8 SPEED
BATTERY	42 PLATES
FRONT TIRES	16 x 6.50 x 8
REAR TIRES	23 x 8.50 x 12
LENGTH	63"
WIDTH	36.5"
WEIGHT (APPROX)	550 lbs



## Big performance garden tractor **MODEL T1228 BT — 11 HP**

A smooth handling versatile tractor with big tractor performance. Rugged 11 horsepower Briggs Synchro-Balanced aluminum alloy engine with 6 forward and 2 reverse speeds that match the power to the task. The safety interlock system prevents starting until clutch lever is in neutral and attachment controls are disengaged. Combination foot operated clutch and brake, with lever operated parking brake, heavy duty battery. Dual spring adjustable seat, twin sealed beam headlights, tail-light and top fuel tank.

Wheel Base: 43"  
 Overall Length: 63"  
 Overall Width: 36.5"  
 Tire Size: Front 16" x 6.50 x 8  
 Rear 23" x 8.50 x 12  
 Shipping Weight: 550 lbs.

MODEL T4328 BT	
ENGINE	TECUMSEH
HORSEPOWER	14
DISPLACEMENT	23.70
IGNITION SYSTEM	SOLID STATE
CYLINDERS	CAST IRON
FUEL TANK (CAPACITY)	TOP 1-3/4
TRANSMISSION	8 SPEED
BATTERY	54 PLATES
FRONT TIRES	16 x 6.50 x 8
REAR TIRES	23 x 8.50 x 12
LENGTH	63"
WIDTH	36.5"
WEIGHT (APPROX)	570 lbs



## The easy-handler garden tractor **MODEL T4328 BT — 14 HP**

Great going and easy handling with the power you need. Tecumseh 14 horsepower cast iron engine with solid state ignition system with the 8 speed all-gear Roper 6+2 Pac power train transmission for the right pull for the job. Separate throttle/choke, keystack, top fuel tank with visual level indicator, independent parking brake, combination clutch/brake, headlights, tail-light.

**Wheel Base: 43"**  
**Overall length: 63"**  
**Overall Width: 36.5"**  
**Tire Size: Front 16" x 6.50 x 8**  
**Rear 23" x 8.50 x 12**  
**Shipping Weight: 570 lbs.**

	MODEL T6328 BT
ENGINE	BRIGGS & STRATTON
HORSEPOWER	16
DISPLACEMENT	40.0
IGNITION SYSTEM	HIGH TENSION MAGNETO
CYLINDERS	2 CAST IRON SLEEVES
FUEL TANK (CAPACITY)	3-1/2 GAL
TRANSMISSION	8 SPEED
BATTERY	66 PLATES
FRONT TIRES	16 x 6.50 x 8
REAR TIRES	23 x 9.50 x 12
LENGTH	65"
WIDTH	36.5"
WEIGHT (APPROX)	625 lbs



## An all-round performer garden tractor **MODEL T6328 BT – 16 HP**

Powered and ready to handle the tough jobs with a Briggs & Stratton 16 horsepower twin cylinder cast iron engine. High tension magneto ignition system for fast sure starting. 6 forward, 2 reverse speeds that match power to the task. Heavy duty 66 plate battery. Neutral interlock systems prevents starting until clutch lever is in neutral and attachment controls are disengaged. Extra wide tires distribute weight to protect the lawn and provide a smooth ride. Rear mounted fuel tank for easier filling – eliminates possibility of spillage on hot engines. Combination foot operated parking brake.

Wheel Base: 43"  
 Overall Length: 65"  
 Overall Width: 36.5"  
 Turning radius: 35" inside  
 Tire Size: Front 16 x 6.50 x 8  
 Rear 23" x 9.50 x 12  
 Shipping Weight: 625 lbs.



MODEL T8328 BT	
ENGINE	ONAN
HORSEPOWER	18
DISPLACEMENT	48.0
IGNITION SYSTEM	AUTOMOTIVE TYPE
CYLINDERS	2 CAST IRON SLEEVES
FUEL TANK (CAPACITY)	3-1/2 GAL
TRANSMISSION	8 SPEED
BATTERY	66 PLATES
FRONT TIRES	16 x 6.50 x 8
REAR TIRES	23 x 10.50 x 12
LENGTH	65"
WIDTH	36.5"
WEIGHT (APPROX)	656 lbs.



## The Little Giant Garden Tractor **MODEL T8328 BT – 18 HP**

Onan twin opposed piston, four cycle twin cylinder, 18 horsepower engine runs quietly, runs smoothly, far less vibration than virtually all single cylinder engines. 8 speed all gear transmission provides ground speeds that match power to the task. Six forward speeds. .85 MPH to 6.56 MPH, two reverse speeds 1.02 MPH to 2.53 MPH, neutral interlock systems prevent starting until clutch lever is in neutral and attachment controls are disengaged. Combination foot operated clutch and brake with lever operated parking brake. Extra wide tires distribute weight to protect the lawn and provide a smooth ride. Keyswitch electric start, running time monitor, twin sealed beam headlights, full fenders and footrests, tail-light and deep padded, high back, spring mounted adjustable seat are just some of the standard features.

Tire Size: Front 16" x 6.5 x 8"  
Rear 23" x 10.5 x 12"  
Wheel Base: 43"  
Overall Length: 65"  
Overall Width: 36-1/2"  
Turning radius: 35" inside  
Shipping Weight: 656 lbs.

### Roper 6+2 Pac Power Train

LOW RANGE			HIGH RANGE			REVERSE	
1ST	2ND	3RD	1ST	2ND	3RD	LOW	HIGH
.85	1.60	2.56	2.10	3.96	6.56	1.02	2.53

MODEL T9329 BT	
ENGINE	ONAN
HORSEPOWER	20
DISPLACEMENT	52.2
IGNITION SYSTEM	AUTOMOTIVE TYPE
CYLINDERS	2 CAST IRON SLEEVES
FUEL TANK (CAPACITY)	3-1/2 GAL
TRANSMISSION	8 SPEED
BATTERY	66 PLATES
FRONT TIRES	16 x 6.50 x 8
REAR TIRES	23 x 10.50 x 12
LENGTH	65"
WIDTH	36.5"
WEIGHT (APPROX)	656 lbs.



## The big job master garden tractor **MODEL T9329 — 20 HP**

For the balance of weight and power to get the big jobs done, this newest addition to our tractor line is the master. Rugged 20 HP Twin Cylinder Onan Engine. Will handle any job you have. 8 speed all gear transmission provides ground speeds that match power to the task. Six forward speeds, .85 MPH to 6.56 MPH, two reverse speeds 1.02 MPH to 2.53 MPH, neutral interlock systems prevent starting until clutch lever is in neutral and attachment controls are disengaged. Combination foot operated clutch and brake with lever operated parking brake. Extra wide tires distribute weight to protect the lawn and provide a smooth ride. Keyswitch electric start, running time monitor, twin sealed beam headlights, full fenders and footrests, tail-light and deep padded, high back, spring mounted adjustable seat are just some of the standard features.

**Tire Size:** Front 16" x 6.5 x 8"  
Rear 23" x 10.5 x 12"  
**Wheel Base:** 43"  
**Overall Length:** 65"  
**Overall Width:** 36-1/2"  
**Turning radius:** 35" inside  
**Shipping Weight:** 656 lbs.

### Roper 6+2 Pac Power Train

LOW RANGE			HIGH RANGE			REVERSE	
1ST	2ND	3RD	1ST	2ND	3RD	LOW-HIGH	
.85	1.60	2.56	2.10	3.96	6.56	1.02	2.53

# Roper big tractor features for big tractor performance

## DUAL AIR FILTER SYSTEM

Donut-shaped, pre-cleaner foam fits snugly over standard filter element to provide double protection. Increases engine efficiency.

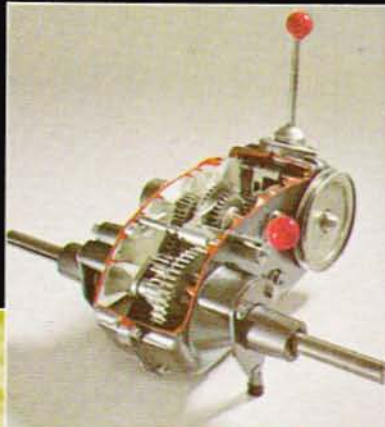

## ROPER 6+2 PAC POWER TRAIN

Rugged Roper-built all-gear transmission provides 6 precise speeds forward from .85 to 6.56 mph, plus 2 reverse speeds of 1.02 and 2.53 mph.



## EASY SPEED SELECTION

With Roper two speed ranges, you can match tractor power to mowing conditions. Gear down to drive the tractor slowly in tall grass. Gear up to run faster across an average lot. And still deliver full-power to the mowing attachment. Equally great performance and dependable power for tilling, grading and snow removal.



## ADJUSTABLE TIE RODS

Automotive type allows adjustments to maintain easy steering. Properly adjusted tie rods eliminate "wandering", helps return to straight ahead after turning.

## HOUR METER

Service Hour Meter on dash keeps accurate operation time. Tells you when to perform necessary servicing. Available on 18 and 20 HP tractors. See Owner's Manual.

another free manual from [www.searstractormanuals.com](http://www.searstractormanuals.com)



# On the farm or in your yard . . . you're rrrridin high with Roper

## HYDRAULIC LOADER ATTACHMENT

### MODEL LRO-100-73

Removing snow from your driveway or hauling manure from inside your barn . . . these and other back-breaking chores are done easily and quickly with this ROPER-LOADER-COMBINATION.

For town and country places the big loaders won't go: In Parks; Motels; Elevators; at Home; Nurseries; Industrial Plants and by Contractors.

### SELF LEVELLING FEATURE:

**Keeps loads in bucket level  
at all times.**

Your Roper Loader Attachment is ruggedly built. It provides the lowest cost, most compact and manoeuvrable material handling unit available for compact tractors. This loader comes complete with its own hydraulic system.

For increased safety and stability, we strongly recommend wheel weights and dual wheels with spacer kits.



### LOADER SPECIFICATIONS

The dimensions as shown below are:

A-8'2" B-49" C-50" D-72" E-60" F-26 1/2"

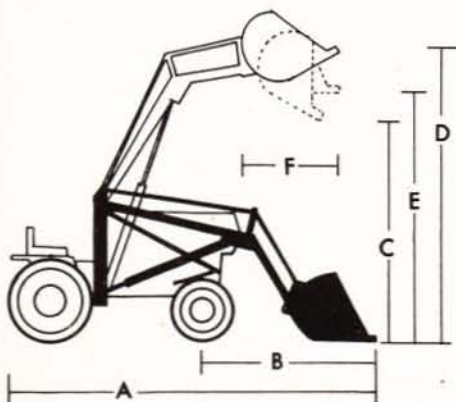

Dimensions will vary with tractor model.

# Attachments.

## 40" Disc Harrow (TT428 BT)

(Requires TA207 AT)

Double gang of 12" high-carbon steel discs can be set in three different positions; cut up trash, break up dirt clods, level and pulverize soil after plowing.



## 10" Plows TT418 AT

(Requires TA207 AT)

Plow a furrow up to 6" deep, 8" wide; 10" plow for 11, 14, 16 H.P., 18 H.P. and 20 H.P. tractors.



## Self Powered 8 H.P. Roto-Tiller (TT508 AT)

Requires TA207 AT

8 H.P. engine drives tiller at constant speed allowing 11" diameter tines to til up to 6" depth with 36" cut. Less jumping and bucking. Non-clogging lines, gauge wheels. Provides excellent garden seed bed preparation.

(If mounted with electric 3 PT Hitch requires TA188 AT Lift link kit)



another free manual from [www.seartractormanuals.com](http://www.seartractormanuals.com)



### Snow Blower (TT648 AT) LAO49 AT (TT679 AT)

(Tire chains and wheel weights recommended)

Whip the worst of winter's weather the easy way. Powerful rotary snow throwers have a unique heavy-duty auger with four discharge paddles. Throws snow forward, left or right. Discharge chute is controlled by worm rotating mechanisms from driver's seat.

Available in 42" width for 16 H.P. and 18 H.P. and 20 H.P. tractors. 40" width for 11 H.P. and 14 H.P.

36" width for 8 H.P. and 11 H.P. lawnt tractor.



### Tractor Tri-Hitch TA207 AT

This heavy duty tri-hitch pulls attachments at proper angles for best performance. Designed for use with Roper tractors, provides a proper line of draft equivalent to hooking up attachment beneath centre of tractor. Tri-Hitch mounts on tractor drawbar with four bolts. Attachments are mounted in less than thirty seconds with three snap pins (no tools needed). Over-centre lift lever permits easy raising and lowering of attachments from drivers's seat. Turn buckles for quick depth and levelling adjustments. Also available TA157 AT Electric Tri-Hitch.



### Dump Carts 755 -109

Rugged, all steel carts 'Tote-around' a lot of flowers, fertilizer, soil, compost, gardening tools, lawn debris... or load them with firewood. Pneumatic tires take it easy on the lawn. Quick hook-up to tractor drawbar. Dump easily with back 'gate' removed. 10 cu. ft. capacity.



### Grader Leveller Blade TT498 T

(Requires TA207 AT)

For levelling soil, grading lanes, driveways, etc. 42" blade attaches easily to tri-hitch with only three snap pins. Tilt and angle of blade is adjustable. Can be used with Roper bulldozer on front of tractor for maximum efficiency.

# Roper accessories give you all-season, all-reason versatility.

## Rear Wheel Weights

Add 70 pounds for improved traction with snow throwing and plowing attachments. Two sets may be used for even greater traction.

Model - TA0231 T All Models



## Three Blade Rotary Mower

Wide-swath mowing from 1.5" to 4.5" scissor mounting and parallel-float, spring loaded snap-pin installation.

Model - TT728 AT 42" for 16 H.P.

Model - TT728 AT 42" for 18 H.P.

Model - TT728 AT 42" for 20 H.P.

Model - TT738 AT 48" for 16 H.P.

Model - TT738 AT 48" for 18 H.P.

Model - TT738 AT 48" for 20 H.P.

Model - TT718 AT 42" for T1228 BT and T4328 BT



## 46" Dozer Blade TT748 AT

Move the snow out of your way quickly, easily... use for levelling and grading dirt or gravel. Free-floating blade can be angled left or right (2 left, 2 right, 1 centre position), raised or lowered from driver's seat. Heavy steel blades and adjustable skid shoes. 46" blade for 11 H.P., 14 H.P., 16 H.P., 18 H.P., and 20 H.P.

Mounting Bracket for Blade

TT758 for 11 H.P. & 14 H.P.

TT768 for 16 H.P., 18 H.P. and 20 H.P.



## Adjustable Cultivator TT463 AT

(Requires TA207 AT)

All models handle rows from 20" to 30" wide or cultivate between rows of 36" or more. Five tempered shanks and five 6" sweeps.

### Tire Chains for Tractors

TA1131 T for 11 H.P.

TA1231 T for 16 H.P.

TA1231 T for 18 H.P.

TA1231 T for 20 H.P.



## ATTACHMENT SELECTION FOR ROPER TRACTORS - 1980

MODEL	42" ROTARY MOWER TT718 AT	42" ROTARY MOWER TT728 AT	48" ROTARY MOWER TT738 AT	10" PLOW TT418 AT	40" DISC HARROW TT428 BT	CULTIVATOR TT4631 T	42" REAR GRADER BLADE TT498 T	38" 8 HP TILLER TT508 AT	46" DOZER BLADE TT748 AT	39" SNOWTHROWER TT679 AT	MANUEL 3 PT HITCH TT648 AT	ELECT 3 PT HITCH TA207 AT	REAR WHEEL WEIGHTS TA187 AT	DUMP CART 755-109	FRONT END LOADER LRO-100-73	TIRE CHAINS (8.50 x 12) TA1131 T	TIRE CHAINS (9.50 x 12) TA1231 T	TIRE CHAINS (10.50 x 12) TA1231 T	ORGANIC SHREDDER 763-108	SNOWTHROWER L4049 AT		
L8218 CT																					•	
L1219 AT																						•
T1228 BT	•				•	•	•	•	•		•	•	•	•		•						
T4328 BT	•				•	•	•	•	•		•	•	•	•		•						
T6328 BT		•	•	•	•	•	•	•		•	•	•	•	•	•		•					
T8328 BT		•	•	•	•	•	•	•		•	•	•	•	•	•				•		•	
T9329 BT		•	•	•	•	•	•	•		•	•	•	•	•	•				•		•	



CANADA LIMITED

P.O. Box 37 Ingersoll N5C 3K2