

Sears
owners
manual

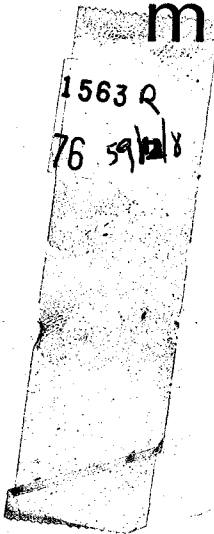

TRACTOR MODEL #
917 257 20

MODEL NO.
917.252031

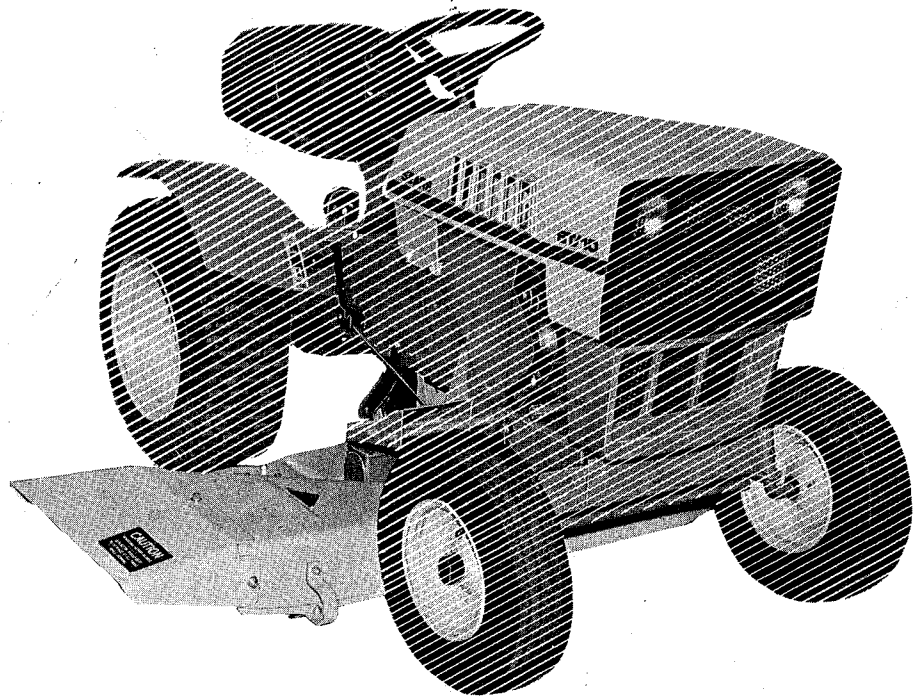

38" ROTARY MOWER FOR CUSTOM TRACTORS

- Assembly
- Operating
- Maintenance
- Repair Parts

Sears, Roebuck and Co., Chicago, Ill. 60607 U.S.A.
and Simpsons Sears Limited, Toronto

GUARANTEE

During the first year, we will repair your mower free of charge if found defective in material or workmanship. This guarantee service is available by simply contacting any of our stores or service centers throughout the United States or Canada.

The guarantee is limited to 30 days if the item is used for commercial purposes.

IMPORTANT

RULES FOR SAFE OPERATION

1. Know the controls, and how to stop quickly -
READ THE OWNER'S MANUAL.
2. Do not allow children to operate Tractor and mower. Do not allow adults to operate them without proper instructions.
3. Do not carry passengers. Keep children and pets a safe distance away.
4. Clear work area of objects which might be picked up and thrown.
5. Disengage mower clutch, and shift into neutral before attempting to start engine.
6. Disengage power to mower and stop engine before leaving operator position.
7. Do not attempt to clean discharge, remove obstacles or otherwise clean, adjust or repair mower before stopping tractor engine, and removing wire from spark plug. Never place hands or feet in or near rotating blades or belts when engine is running.
8. Disengage power to mower when transporting or not in use.
9. Take all possible precautions when leaving tractor and mower unattended: such as disengaging power take-off, lowering mower, shifting into neutral, setting parking brake, stopping engine and removing key.
10. Do not stop or start suddenly when going uphill or downhill. Drive up and down the face of steep slopes, never across the face.
11. Reduce speed on slopes and in sharp turns to prevent tipping or loss of control. Exercise extreme caution when changing direction on slopes.
12. Stay alert for holes in terrain and other hidden hazards.
13. Use care when pulling loads or using heavy equipment:
 - A. Use only approved drawbar hitch points.
 - B. Limit loads to those you can safely control.
 - C. Do not turn sharply. Use care when backing.
 - D. Use counter weight (S) or wheel weights when suggested in owners manual.
14. Watch out for traffic when crossing or near roadways.
15. When using mower never direct discharge of material towards bystanders, windows or buildings. Never allow anyone near vehicle while in operation.
16. Handle gasoline with care--it is highly flammable.
 - A. Use approved gasoline container.
 - B. Never remove cap or add gasoline to a running or hot engine. Never fill fuel tank indoors. Wipe up spilled gasoline.
 - C. Open doors if engine is run in garage--exhaust fumes are dangerous. Do not run engine indoors.
 - D. Never smoke while refueling engine.
17. Keep tractor and mower in good operating condition and keep safety devices in place.
18. Keep all nuts, bolts, and screws tight to be sure equipment is in safe working condition.
19. Never store tractor with gasoline in tank inside a building where fumes may reach an open flame or spark.
20. Allow engine to cool before storing in any enclosure.
21. To reduce fire hazard keep engine free of grass, leaves or excessive grease.
22. Tractor and Mower should be stopped and inspected for damage after striking a foreign object and damage should be repaired before restarting and operating the equipment.
23. Do not change engine governor settings or overspeed engine.
24. When using tractor with mower:
 1. Mow only in daylight or in good artificial light.
 2. Never make any adjustment while engine is running.
 3. Shut engine off when unclogging chute.
 4. Check blade mounting bolts and all other bolts, nuts etc. for proper tightness at frequent intervals.

reference drawing for assembly and instructions

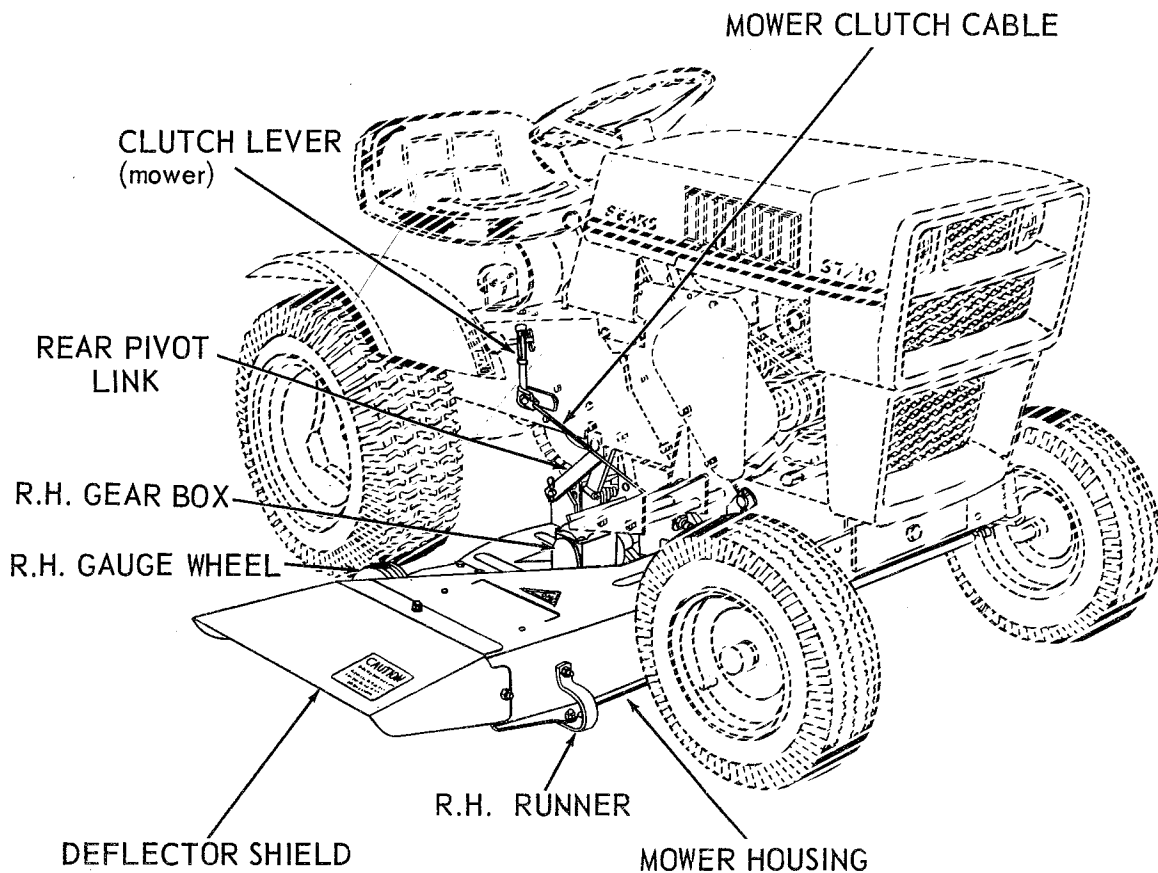

FIG. 1

This tractor or attachment has been designed, engineered and manufactured to give you the best possible dependability and performance.

Should you experience any problem you cannot easily remedy, please contact your nearest Sears Roebuck or Simpsons-Sears, Ltd. Service Dept. They have well qualified, competent trained technicians and the proper tools to service or repair this unit.

It is important that the operator ALWAYS OBSERVES THE "RULES FOR SAFE OPERATION" as well as other instructions contained in these manuals.

Your new rotary mower attachment utilizes multiple sharp cutting blades rotating about vertical shafts within the housing. These blades rotate at 14,000 feet per minute. The blades slice grass at approximately 158 miles per hour to provide a uniformly cut lawn. Grass clippings are exhausted through the mower discharge area by the fast flow of air created by the revolving blades.

The Rotary Mower has been shipped from the factory partially assembled, for shipping purposes. All parts necessary to complete assembly are included in plastic bags within the carton. The bags of parts include the following items:

Use this bag of parts to mount mower to tractor without mower clutch lever

- * 1 Blade Clutch Lever
- 1 Handle Grip
- 1 Spring
- 1 Clutch Decal

Items with * are used in both applications

Use this bag of parts to mount mower to tractor with mower clutch lever attached

- | | |
|------------------------------|-------------------------|
| 2 Blade Safety Drive Washers | * 2 Carriage Bolts |
| 1 Spring | * 1 Rd. Hd. Mach. Screw |
| * 1 Pulley Guard Guide | * 7 Flat Washers |
| 2 Rivet Pins | * 9 Lockwashers |
| * 2 Retainer Springs | * 7 Hex Nuts |
| * 2 Bushings | 2 Cotter Pins |
| * 6 Hex Bolts | |

table of contents

GUARANTEE	1
ASSEMBLY INSTRUCTIONS	3-6
OPERATING	7-8
MAINTENANCE	8-9
REPAIR PARTS	10-14

assembly

Assembly as well as all of the different sections of this Owners Manual should be studied very closely before beginning to assemble your Rotary Mower.

A letter in parentheses in the following instructions refers to an arrow in an adjoining Figure (illustration), unless otherwise stated. When R.H. (Right Hand) or L.H. (Left Hand) is used, it means from a position behind the steering wheel as if one were seated on the tractor seat and facing forward.

1. Cut all wires, remove mower, plastic bags, and other parts from carton. Plastic bag contains parts, and hardware necessary for the assembly of mower. Lay out parts for assembly, and separate bolts etc. according to size.

assembly of lift lever to tractor

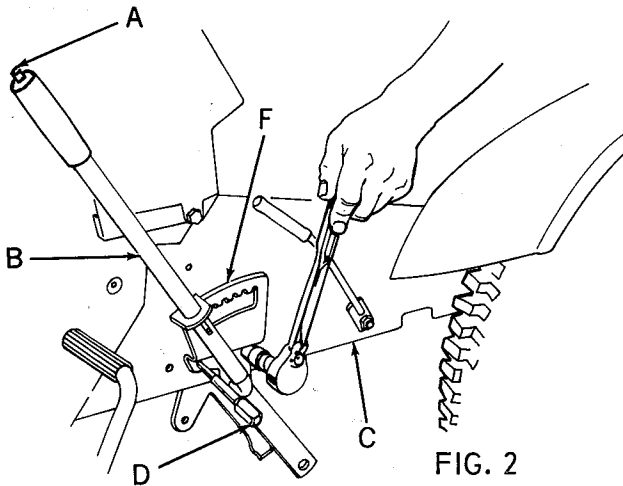

2. Refer to Fig. 2. Depress button (A) on top of lift lever, and move lift lever to center of quadrant (F). Release button, lever will lock in notch of quadrant. NOTE: Make sure threads in mounting channel are free from paint.
3. Refer to Fig. 2. Position lift lever assembly (B), under tractor (C) with lever to left hand side of tractor. Raise the lift lever assembly into position, so that quadrant (F) will be outside of tractor, and mounting channel (with threads) will be inside tractor frame. Line up front hole in quadrant, L.H. tractor frame, and mounting channel. Insert punch (D) (or similar tool) to keep holes in line.

3828R-8.1.73

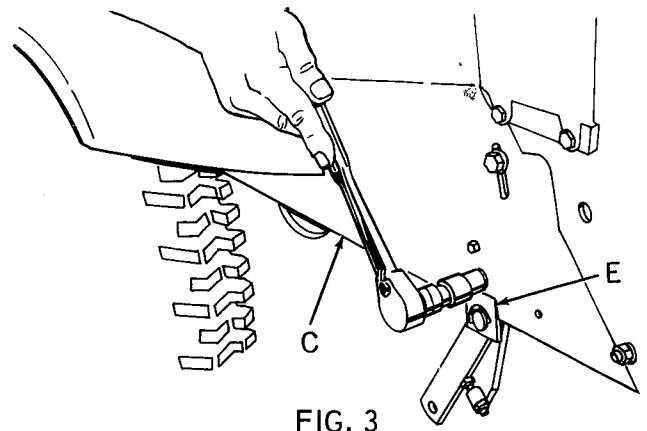

FIG. 3

4. Refer to Fig. 3. Assemble lifter bracket (E) to R.H. side of tractor frame (C) as shown. Secure lifter bracket to tractor frame with 1-3/8 x 1 hex bolt, (head to outside) lockwasher, and hex nut provided. Leave bolt loose.
5. Refer to Fig. 2. Line up rear hole of quadrant (F), L.H. tractor frame (C), and mounting channel. Secure with a 3/8 x 1 hex bolt, and lockwasher provided.
6. Remove punch (D) or similar tool from front hole of quadrant (F), and secure with a 3/8 x 1 hex bolt, and lockwasher provided.
7. Depress button (A) (Fig. 2) on top of lever, and move lever forward and backward. Then tighten all 3 bolts securely.

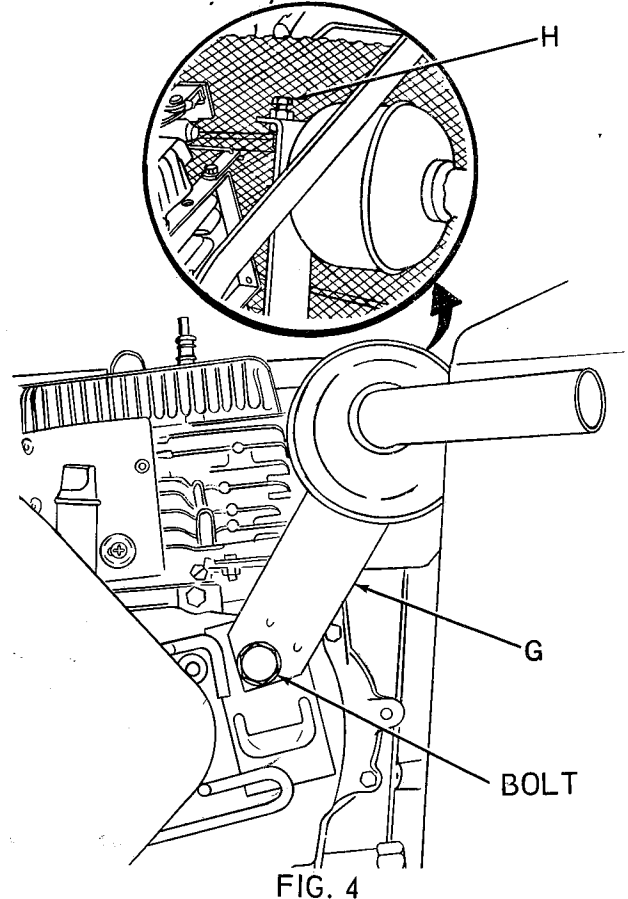

FIG. 4

8. Refer to Fig. 4. Remove belt guide (G) from around engine pulley. Some tractors have two bolts holding belt guide (G) to engine, and some have only one. If belt guide is also fastened to muffler. It will be necessary to loosen bolt (H) in belt guide bracket at muffler to swing belt guide away from engine pulley.

assembly (cont.)

assembly of deflector shield to mower housing

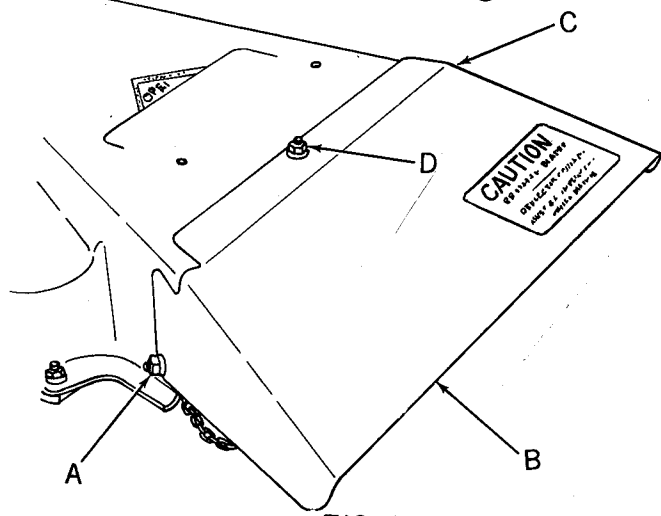

FIG. 5

1. Refer to Fig. 5. Remove bolt (A) from rear of mower housing (discharge end).
2. Make sure chain links are not kinked, and slip shield (B) over discharge end of mower housing as shown. Replace bolt (A) (head to inside) through mower housing and shield (B). Slip a 11/32 x 11/16 x 16 Ga. washer (found in plastic bag) on bolt. Secure with lockwasher, and hex nut, which was previously removed. Leave bolt loose.
3. Insert a 5/16 x 3/4 carriage bolt (C) (head to inside) through front of mower housing, and shield (B). Secure with a 11/32 x 11/16 x 16 Ga. washer, lockwasher, and hex nut. Bolt washers, and hex nut will be found in plastic bag.
4. Insert a 5/16 x 3/4 carriage bolt (D) (head to inside) through top center of housing and shield, in same manner as step 3 above. NOTE: Be sure shield is down against mower housing. Tighten all 3 bolts securely.

assembly of gauge wheels

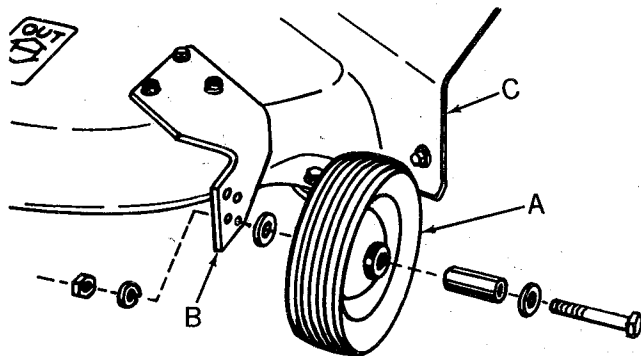

FIG. 6

1. Refer to Fig. 6. Assemble gauge wheels (A) to gauge wheel bracket (B). NOTE: Thicker portion of wheel hub must be toward gauge wheel support (B). A bushing must be inside each wheel hub, and a 3/8 x 7/8 x 14 Ga. washer must be on each side of wheel. Secure with a 3/8 x 2 3/4 hex bolts, 3/8 lockwasher, and 3/8 hex nut.

Normally the wheels should be assembled to the bottom hole. This will give a normal cutting height of approximately 1-7/8 inches. See Fig's. 21 and 22, Page 7.

assembly of mower for tractor without clutch lever (mower)

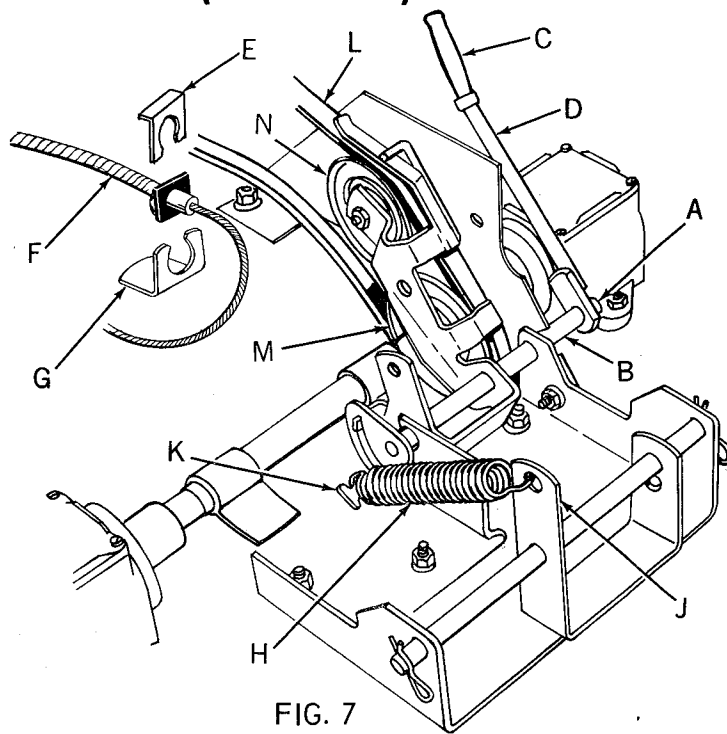

FIG. 7

1. Refer to Fig. 7. Remove nut (A) from end of control arm assembly (B).
2. Slip rubber handle grip (C) found in plastic bag (which contains small spring and decal) over end of blade clutch handle (D). Place blade clutch handle (D) on end of control arm assembly (B). NOTE: There are two flat positions on control arm, be sure flat portion of clutch handle fits over flat portion of control arm assembly. Replace hex nut (A) and tighten securely.
3. Remove spring clip (E) holding clutch cable (F) to front mower housing mounting weldment (G), and remove cable (F) and discard. This cable is used only when mower is used on a tractor equipped with a clutch lever (mower).
4. Assemble small spring (H) found in bag with decal to housing mount assembly (J) and to control arm assembly (K) as shown.
5. Place mower drive belt (L) on pulley (M) of cross shaft and on idler pulley (N) as shown.
6. Rotate blade clutch handle (D) forward.

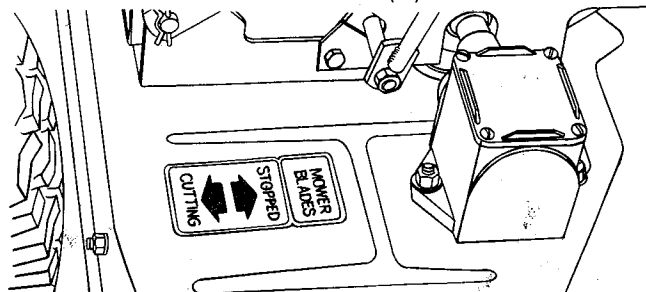

FIG. 8

7. Remove paper backing from underside of clutch decal and apply to mower housing as shown.

assembly (cont.)

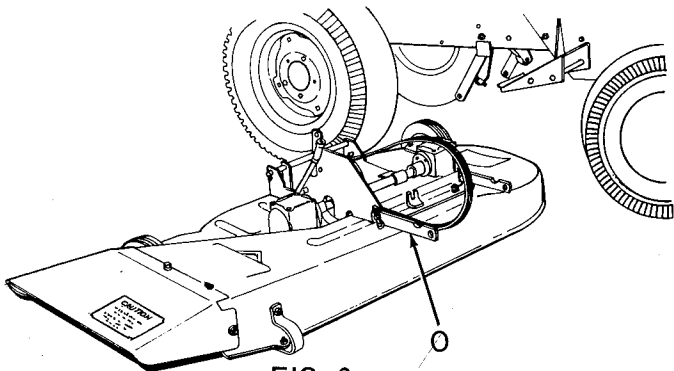

FIG. 9

8. Turn front wheels of tractor to the left. Make sure front pivot links (O) are forward as shown. Slide mower under R.H. side of tractor.

assembly of mower to tractor equipped with clutch lever (mower)

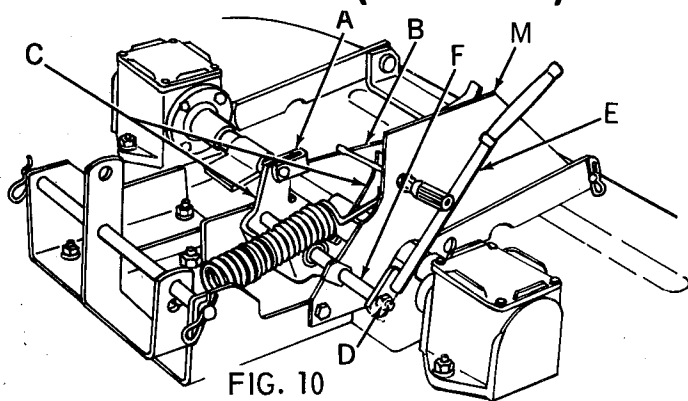

FIG. 10

1. Refer to Fig. 10. Assemble clevis (A), on cable (B), to idler bracket (C), with rivet pin, and cotter pin provided.
2. Remove nut (D) from end of control arm assembly. Slip blade clutch handle (E) found in plastic bag with decal on control arm assembly (F) and replace nut (D).

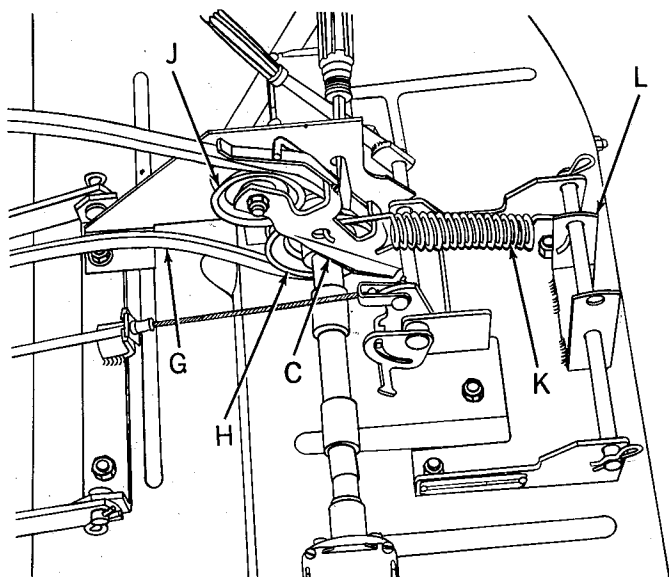

FIG. 11

3. Refer to Fig. 11. Place belt (G) on pulley (H) of cross shaft, and on idler pulley (J) as shown. Assemble largest spring (K) from idler bracket (C) to mounting angle rear (L) as shown. **IMPORTANT:** Long hook of spring (K) must be to idler bracket (C) and hook end away from belt (G) as shown.
4. Refer to Fig. 10. Rotate blade clutch handle (E) forward. Lock in that position, by inserting screw driver or similar tool, back of handle (E), through hole in pulley guard (M), and back of idler bracket (C) as shown.

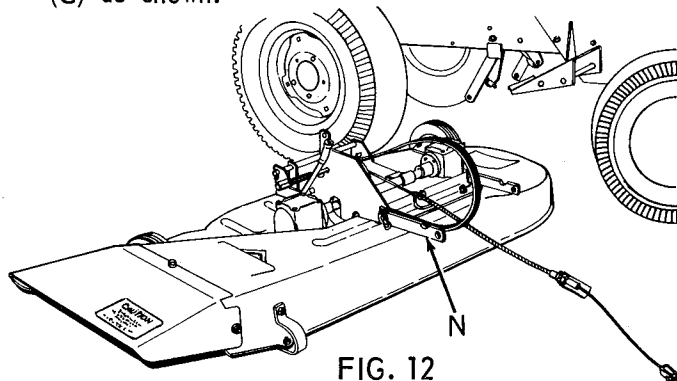

FIG. 12

5. Refer to Fig. 12. Make sure front pivot links (N) are forward as shown. With front wheels turned to left, slide mower under R.H. side of tractor.

assembly of mower to tractor

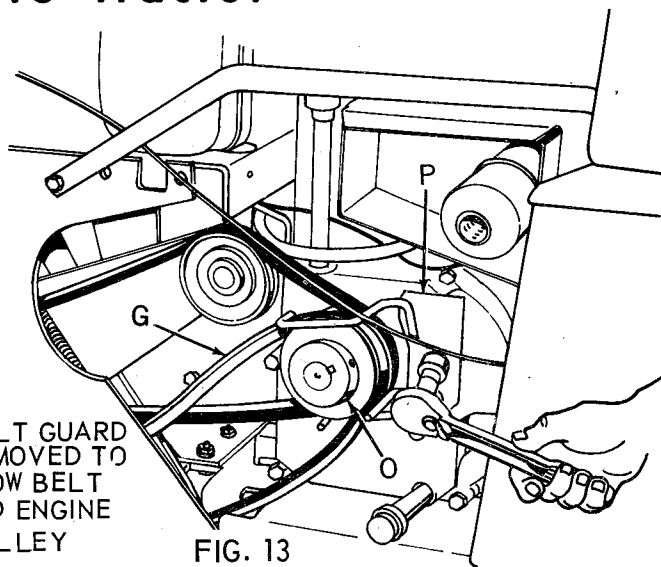

FIG. 13

6. Refer to Fig. 13. Thread mower drive belt (G) up through tractor frame to engine pulley (O). **NOTE:** Belt guard can be pulled out far enough so that belt will pass between guard and engine pulley. Replace belt guide (P) on engine around pulley. Make sure bolt or bolts are replaced and tightened, depending on tractor model. **IMPORTANT:** There must be 1/8" clearance between fingers on belt guide and drive belts when clutches are engaged (belts are tight). **NOTE:** Belt guard is removed to show belt and engine pulley.

ALWAYS KEEP ALL SHIELDS, AND SAFETY DEVICES IN PLACE. NEVER DIRECT DISCHARGE OF MATERIAL TOWARD BYSTANDERS, OR BUILDINGS. NEVER ALLOW ANYONE NEAR MACHINE, WHILE IN OPERATION.

assembly (cont.)

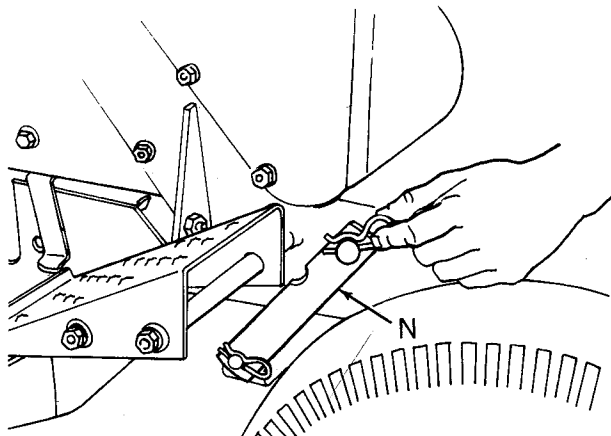

FIG. 14

7. Refer to Fig. 14. Attach two front links (N), to pins on each side of tractor as shown. Secure with retainer springs provided.

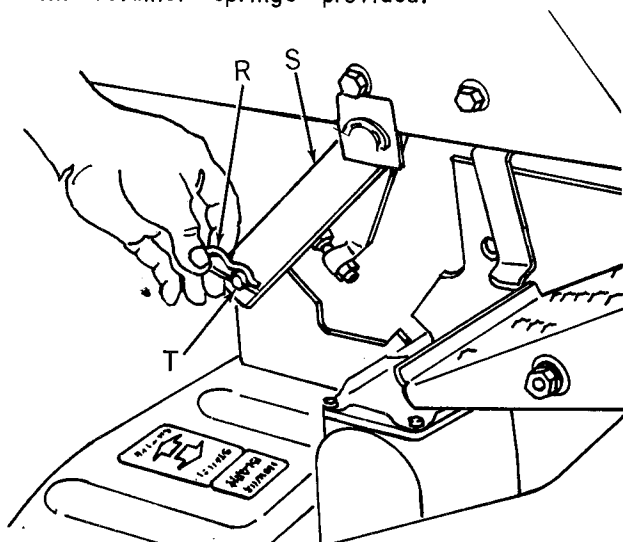

FIG. 15

8. Refer to Fig. 15. Move lift lever to forward position. Remove retainer springs (R) from end of pivot shaft (T). Slip lower ends of rear pivot links (S) on end of pivot shaft (T), and secure with retainer springs (R), one on each side of tractor.

attach clutch cable to tractor

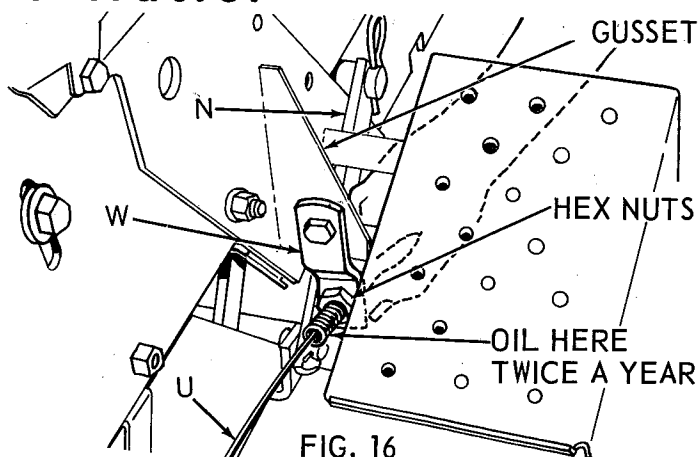

FIG. 16

9. Refer to Fig. 16. Swing cable (U) around so that it will be between R.H. front pivot link (N) and R.H. front tractor tire.

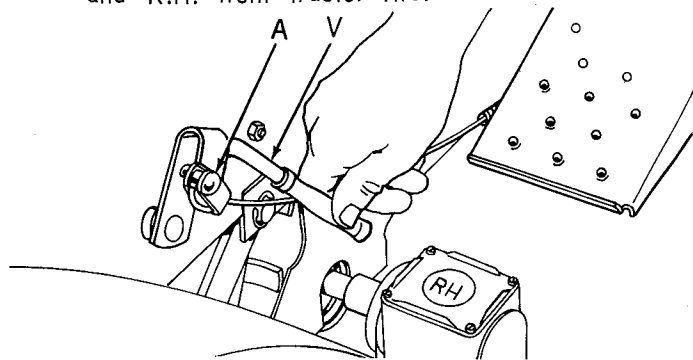

FIG. 17

10. Refer to Fig. 17. Insert rivet pin in cable clevis (A), and secure with cotter pin provided.
11. Refer to Fig. 16 & 17. Slip cable clevis (A) with pin on clutch lever (mower) (V) on tractor, as shown. Attach clutch cable anchor (W) to gusset Fig. 16 on R.H. foot rest of tractor, with a 3/8 x 1 hex bolt, lockwasher, and hex nut provided. NOTE: Make sure cable anchor (W) hangs straight down as shown. Tighten bolt securely. Make sure hex nuts on cable are tight against cable anchor.

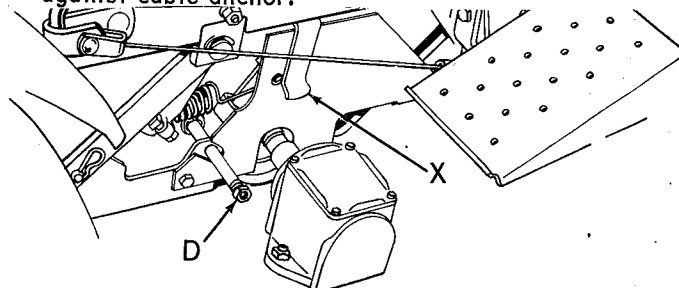

FIG. 18

12. Refer to Fig. 18. Rotate blade clutch handle (E) forward, and remove screwdriver or similar tool, which was holding idler bracket forward. Remove nut (D), Fig. 18 and blade clutch handle (E), Fig. 10 from control arm assembly. Replace nut on shaft to protect threads. Save blade clutch handle. This handle will be used as mentioned above to hold idler bracket while removing or assembling mower to tractor.
13. Refer to Fig. 18. Lower mower by depressing button on top of lift lever, and moving lever forward. Assemble pulley guard guide (X) to tractor frame as shown. Secure with round head mach. screw (head to inside), lockwasher, and hex nut provided. Tighten nut securely.

IMPORTANT: ADJUST BELT GUIDE

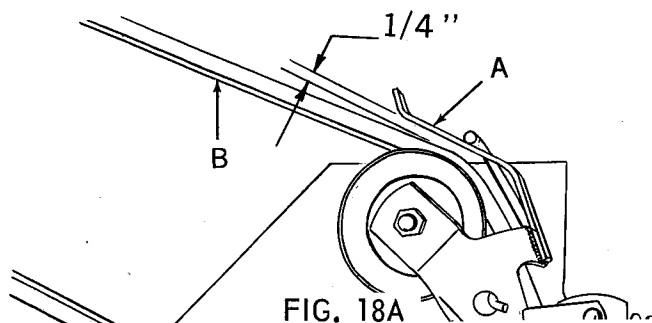

FIG. 18A

Refer to Fig. 18A. After the mower is attached to the tractor, engage mower blade clutch handle. Tractor engine must be stopped. Note the position of belt guide (A), in relation to the belt (B). Clearance must be 1/4 inch.

instruction before operating

adjust mower from side to side

height of cut adjustment

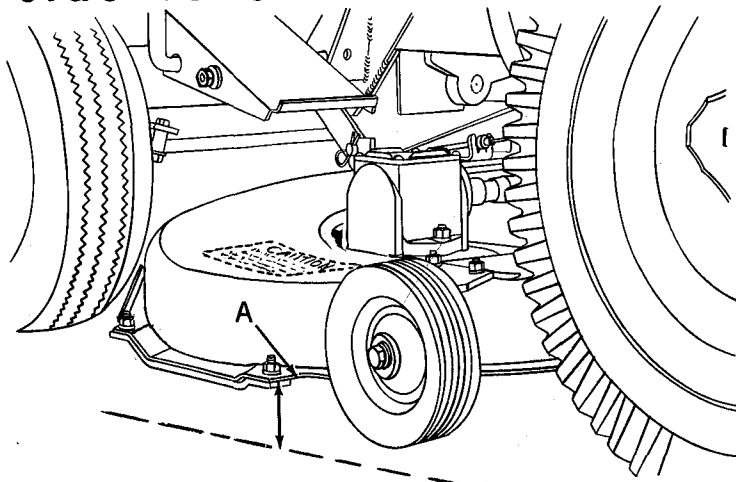

FIG. 19

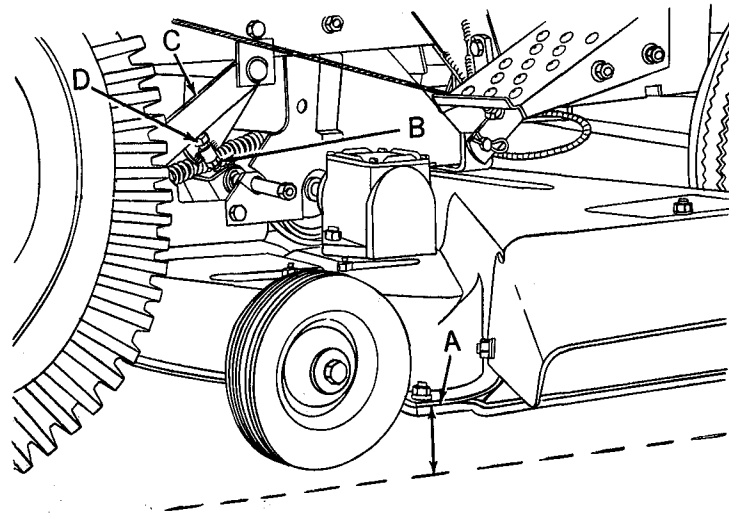

FIG. 20

1. Refer to Figs. 19 and 20. Inflate tires to recommended pressures. Place tractor, with mower mounted on a smooth level surface. Lift mower with lift lever until runners and gauge wheels are off the level surface. Measure the distance down from rear of housing (A) (at rear runner attaching points) to level surface. Distance down on both ends of mower must be the same. If not mower will not cut level from side to side.
2. Refer to Fig. 20. If mower is not level, loosen jam nut (B) on sq. hd. set screw in R.H. lift arm (C). If R.H. side of mower is low unscrew set screw (D) from lift arm. If R.H. side of mower is high screw set screw down into lift arm. Adjust screw until both sides of mower are level (same distance to level surface). Then lock in that position by tightening jam nut (B) securely against lift arm (C).

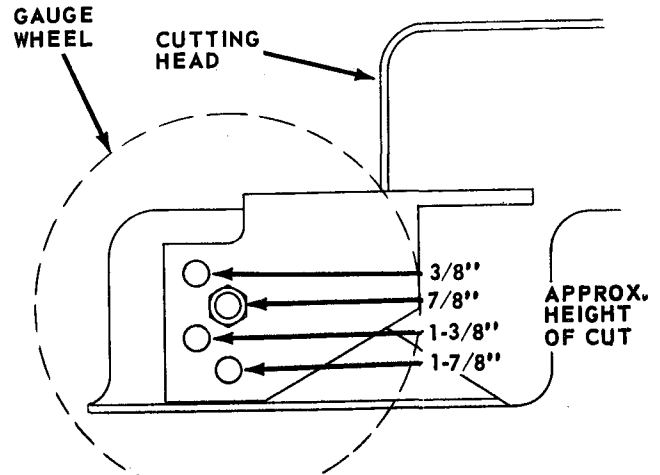

FIG. 21

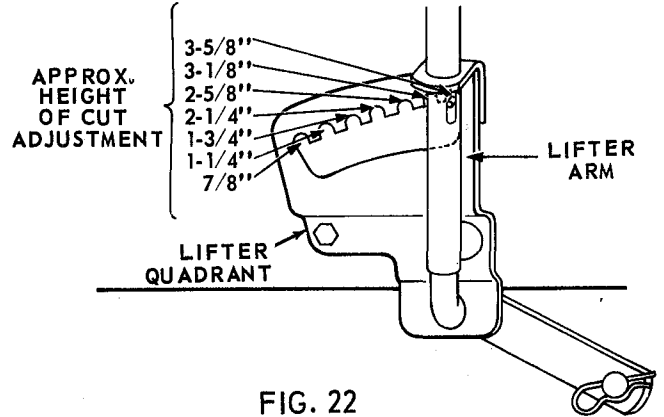

FIG. 22

The cutting height of this mower is determined by the position of the gauge wheels on the cutter head or by the position of the lifter arm. See Figures 21 and 22.

The cutter head is of the full floating type and will closely follow the contours of the ground when using the gauge wheels for the height of cut position.

However, if gauge wheels are suspended slightly no tearing of the turf will occur on sharp turns by gauge wheels sliding sideways. Therefore it is recommended that the lifter arm be used for height of cut, see Figure 22, and adjust gauge wheels to clear ground by approximately 1/2 inch, see Figure 21, when tractor is on level ground and lifter arm has been set to height of cut desired.

To operate the lifter arm depress button on top of lifter arm and move lifter arm to desired height of cut, see Figure 22. Release button so that pin will engage desired notch in lifter quadrant. This locks mower in that height position.

READ "RULES FOR SAFE OPERATION" ON PAGE ONE CAREFULLY BEFORE OPERATING YOUR MOWER.

OPERATING INSTRUCTIONS

BEFORE CUTTING AN UNFAMILIAR PLOT OF GRASS, ALWAYS STOP TO ANALYZE THE LAWN OR FIELD FOR BEST MOWING PROCEDURE. CONSIDER ALSO THE HEIGHT OF GRASS TO BE MOWED. TYPE OF TERRAIN (LEVEL, HILLY OR PITTED), AS WELL AS THE PRESENCE OF ROCK OR TRASH. EACH CONDITION WILL REQUIRE CERTAIN ADJUSTMENTS OR PRECAUTIONS AS OUTLINED IN THIS MANUAL.

DO NOT STOP OR START SUDDENLY WHEN GOING UPHILL OR DOWNHILL. OPERATE MOWER UP AND DOWN THE FACE OF SLOPES; NEVER ACROSS THE FACE. NEVER OPERATE MOWER ON SLOPES WITH MORE THAN A 15 DEGREE SLOPE.

The blade clutch handle is located at right hand of mower on cutter head or on R.H. side of tractor frame depending on tractor. The blade clutch handle engages the mower blades.

1. Set engine speed to about half throttle before engaging or disengaging mower. In either case, engage or disengage blade clutch handle slowly. After mower is engaged, set to full throttle. Caution: Never engage mower except when sitting on tractor seat, and keep hands and feet from beneath the housing. After mower is engaged, advance throttle lever to full throttle.
2. Push down on foot pedal and move gear shift lever to speed desired. Normal cutting speed is 1st gear on a three speed custom tractor, 2nd gear on a four speed custom tractor, or 3rd gear low range on a eight speed custom tractor. If engine pulls down, shift to a lower gear on four and eight speed tractors, and cut less than a full width cut on a three speed custom. In extreme heavy cutting it may be necessary to use the lowest gear and take a narrower cut.

Do not operate the tractor in high gear going down hill, and do not turn sharp corners while going down hill. If it is necessary to stop tractor while going down hill, do so quickly to prevent tractor from picking up speed during the de-clutching to braking operation. NOTE: The engine produces considerable braking action when throttled back to idling speed without de-clutching, and this procedure is recommended before applying brake.

3. Normal cutting height is 1-7/8 inches, height of cut can be adjusted by means of lift lever. Moving the lever forward lowers the mower, while moving it backwards raises the mower.

With lift lever set to height of cut desired and with tractor and mower on level ground, adjust gauge wheels so that they clear the ground by approximately 1/2 inch.

4. Make left hand turns when mowing, this spreads the grass clippings evenly over the grass which has been cut. Grass is mowed regularly (do not let grass get too high), there is little or no raking necessary after mowing.

WHEN MOWING NEXT TO BUILDINGS OR FLOWER BEDS THE TRACTOR SHOULD BE DRIVEN SO THAT THE DISCHARGE OF MOWER WILL BE AWAY FROM BUILDING OR FLOWER BED.

Do not shift gears while going up steep hills. Choose a low enough gear to climb hill without stopping and shifting gears. If it is necessary to stop while going up hill, do so quickly to prevent tractor rolling backward. When starting tractor in motion going up hill, use one of the lowest gears, reduce engine speed and engage clutch gradually to prevent tractor from "rearing up".

maintenance lubrication

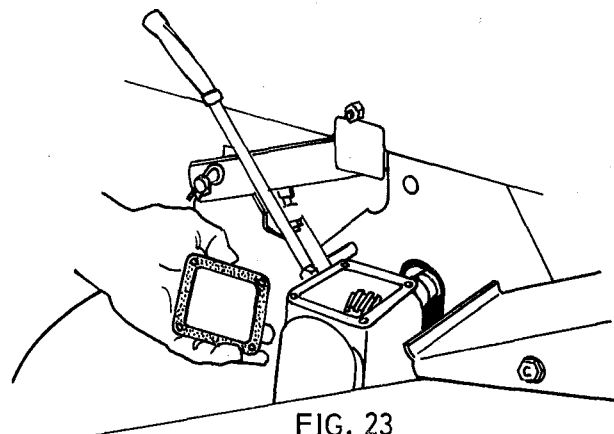

1. Check grease in gear boxes after each fifty hours of operation. Each gear box should be approximately 1/2 full. Lubrication - Gear case moly E.P. lithium grease 4 oz. required in each gear box. Can be purchased from Sears automotive department.
2. To check, remove gear box cover by unscrewing 4 screws. See Figure 23.
3. Refer to Page 6, Fig. 16. Lubricate cable with light oil, twice a year.



STUDY RULES FOR
SAFE OPERATION...

maintenance (cont.)

blade care

For best results, cutting blade must be kept sharp. The blade can be sharpened with a few strokes of a file, or on a grinding wheel. Do not attempt to sharpen while on mower.

When grinding, care should be taken to maintain blade balance and the blade should be checked for proper balance before re-installation on mower. Imbalance of blade or bent blade will cause excessive vibration when running, and eventual damage to mower or engine.

To insure satisfactory operation, it is recommended that before the start of each mowing season, the old blades be discarded and replaced with new blades. Mower blades can be ordered at all Sears retail stores and mail order outlets.

CAUTION: BE SURE TO REMOVE ENGINE SPARK PLUG WIRE BEFORE ATTEMPTING TO REMOVE BLADE.

blade safety drive washer

This mower has a blade safety drive washer on each blade shaft. This is a soft piece between blade and shaft so engineered that if the blade strikes a solid object this blade safety drive washer will break, preventing damage to expensive shaft or mower blade.

Two extra blade safety drive washers are shipped with each mower, and can be found in the plastic bag with other small parts and Instruction Book.

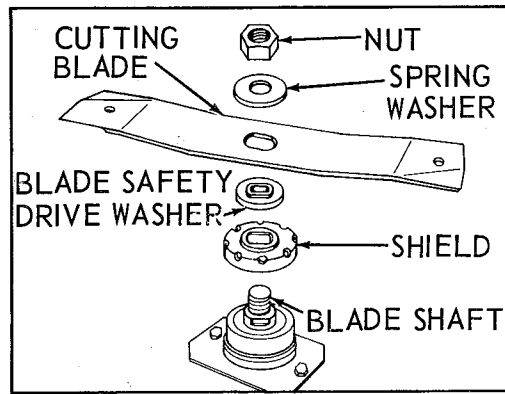

FIG. 24

blade replacement

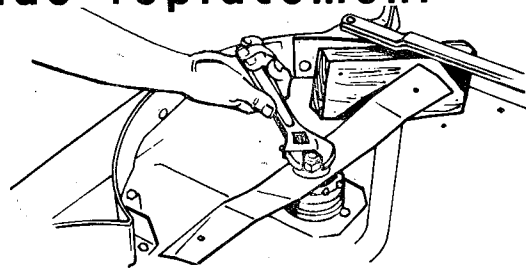

FIG. 25

1. Mower can be removed from tractor to replace blades. Wedge a wood block between blade and mower housing to hold mandrel from turning when removing nut holding blade.

Threads on shaft are R.H. Remove spring washer, and slip blade from blade safety drive washer. Remove blade safety washer and shield from shaft and examine. IF DAMAGED, REPLACE. TWO EXTRA BLADE SAFETY DRIVE WASHERS WERE SHIPPED WITH MOWER. Reassemble shield, blade safety drive washer, blade, spring washer, and nut. Tighten nut securely. NOTE: REFER TO FIGURE 24 FOR SEQUENCE OF REPLACING BLADE.

cleaning mower

Water pressure from a garden hose can be used in cleaning underside of housing, if cleaned immediately after use before clippings under mower have a chance to dry out.

For cleaning underside of mower that has dry packed clippings, place tractor in gear or engage parking brake. Jack up front of tractor and clean underside of mower with putty knife or similar tool. IMPORTANT: Raise front end of tractor using a Sears special riding tractor jack, or a substantial block under each front wheel, and block up, mower attachment so that there is no possible way for mower or tractor to fall. Mower attachment may be removed from tractor for cleaning. Clean underside of mower with putty knife or similar tool.

This should be done whenever an accumulation of grass builds up under mower. Mower will do a much better job of mowing if underside of mower is kept clean.

to remove mower from tractor

1. If tractor is equipped with clutch lever (mower) mounted on tractor. Refer to Figures 10, Page 5. Use steps 2 and 4. This will lock idler arm forward, so that mower can be easily removed.
2. Refer to Page 4, Fig. 8. When clutch lever is on the mower, push blade clutch handle forward to "stopped" position.

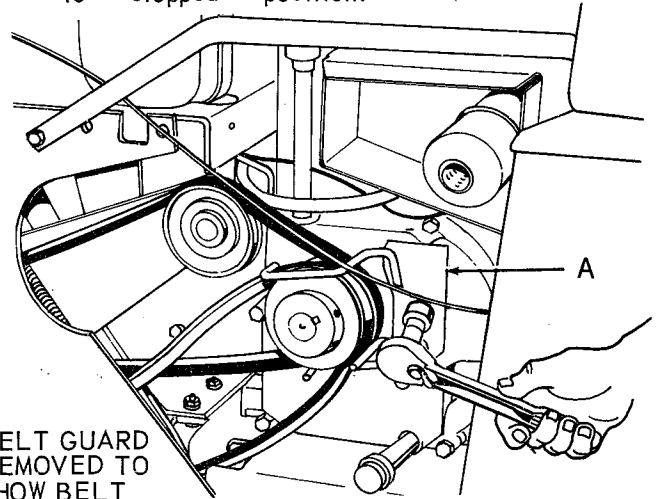

BELT GUARD REMOVED TO SHOW BELT AND ENGINE PULLEY FIG. 26

3. Refer to Fig. 26. Remove belt guide (A) from around engine pulley. Some tractors have two bolts holding belt guide (A) to engine, and some have only one. If belt guide is also fastened to muffler. It will be necessary to loosen bolt (H) (Page 3, Fig. 4), in belt guide bracket at muffler to swing belt guide away from engine pulley. Remove belt from engine pulley. Push belt down through tractor frame. Belt guard can be pulled out far enough for belt to pass between guard and engine pulley.

to remove mower from tractor (cont.)

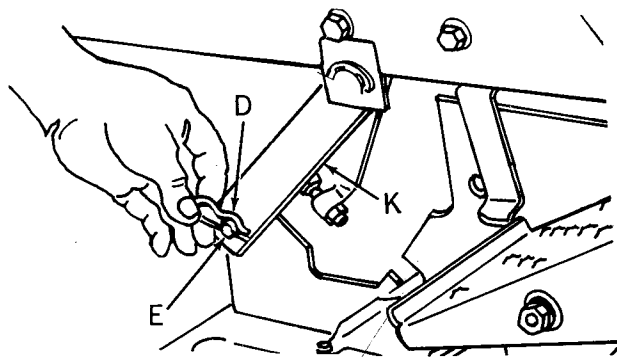

FIG. 27

4. Refer to Fig. 27. Remove retainer springs (D) from pivot shaft (E) and slip rear pivot links (K) from ends of shaft. Replace retainer spring on shaft to prevent losing them.

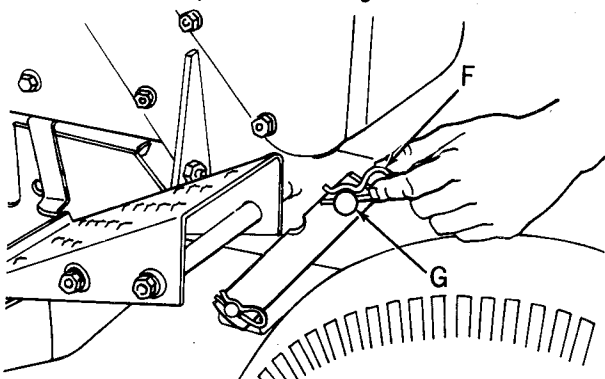

FIG. 28

5. Detach front pivot links by pulling retainer spring (F), and remove links from pivot pin (G). Replace retainer spring in pivot pin to prevent losing it.

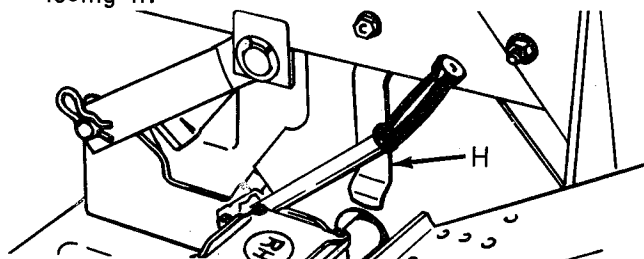

FIG. 29

6. Remove pulley guard guide (H) from tractor frame. Save guide, screw and nut so that it can be reassembled to frame when mower is reassembled to tractor.

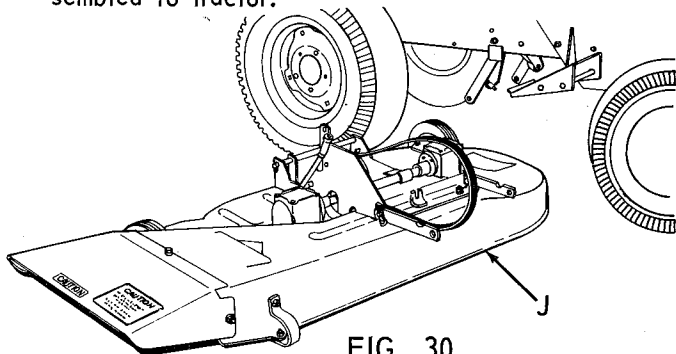

FIG. 30

7. Refer to Fig. 30. Slip mower housing (J) out from R.H. side of tractor.

3828R-8.1.73

belt replacement

The mower drive belt can be replaced without removing mower head from mower if so desired. See steps below for removing belt.

1. Remove mower from tractor. See "To Remove Mower From Tractor", pages 9 & 10.

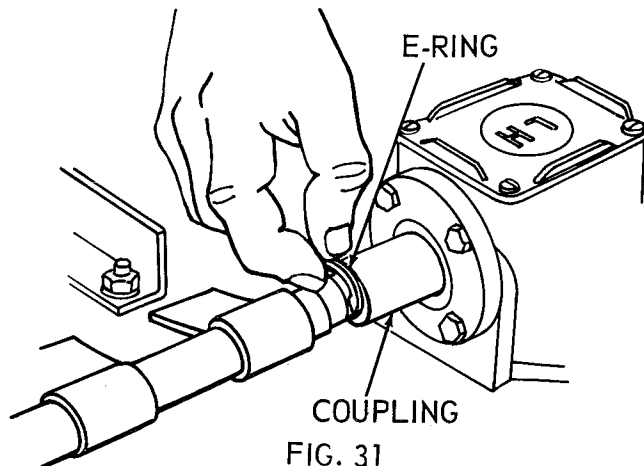

FIG. 31

2. Refer to Fig. 31. Remove two E rings from both ends of shaft and pulley assembly.

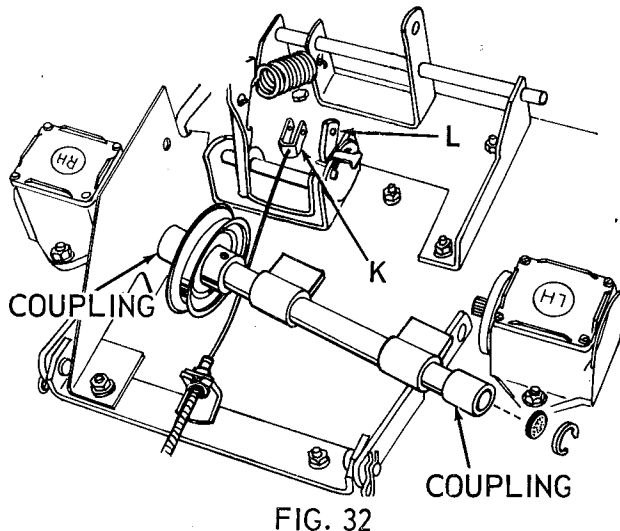

FIG. 32

3. Remove cable clevis (K) from idler bracket (L) if mower is so equipped.
4. Slide couplings toward center of mower. This releases shaft and pulley assembly from gear boxes. See Figure 32.
5. Lift shaft and pulley assembly, remove old belt and replace with new belt.
6. Check that blades are at right angles to each other. If they are not, blades will strike each other and cause damage to blades, blade safety drive washers, etc. Put shaft and pulley into position. Slip couplings outward so that shaft and blade drive boxes are connected and replace E-rings to lock couplings in place.

CAUTION: RECHECK BLADE TIMING TO BE SURE THAT THE BLADES ARE AT RIGHT ANGLES TO EACH OTHER. REATTACH CABLE CLEVIS (K) TO IDLER BRACKET (L).

Reverse procedure for reassembly

CAUTION: Be sure felt disc (Key No. 3, page 11), is in proper position. Lubricate felt disc with a couple drops of No. 30 motor oil.

repair parts

38" ROTARY MOWER--MODEL NUMBER 917.252031

another free manual from www.searstractormanuals.com

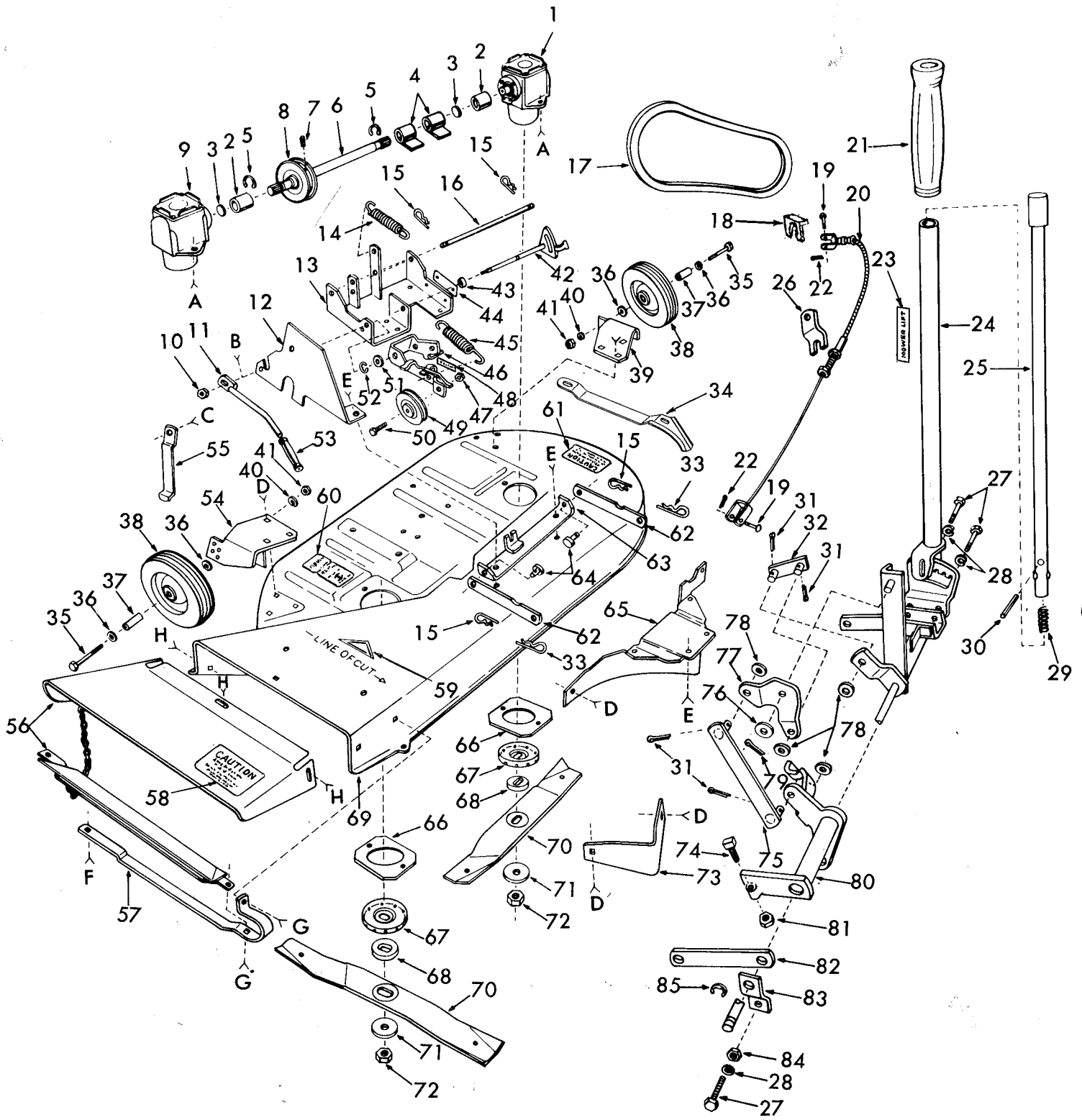

A	B	C	D	E	F	G	H

repair parts

38" ROTARY MOWER--MODEL NUMBER 917.252031

KEY NO.	PART NO.	DESCRIPTION	KEY NO.	PART NO.	DESCRIPTION
1	794042	Head Assembly L.H.	54	626A284	Wheel Bracket Assembly R.H.
2	786028	Coupling, Input Connector	55	8310H1	Pulley Guard Guide
3	788039	Disc, Felt	56	626A356	Deflector Assembly w/chain
4	2037R	Wiper Sleeve	57	960R	Runner R.H.
5	5231H	Crescent Ring	58	3538R	Deflector-Caution Decal
6	776085	Shaft, Input Connector	59	3239R	Safety Standard Sticker
7	792027	Set Screw, Knurled Hd. C.P. 5/16-24 x 1/4	60	2185R	Clutch Decal
8	786059	Sheave	61	3539R	Instruction-Caution Decal
9	794041	Head Assembly R.H.	62	5050H	Pivot Link Front
10	511P	Nylock Nut 3/8-24	63	626A352	Mower Housing Mounting Weldment
11	626A271	Blade Clutch Handle	64	1032R	Pivot Pin
12	7717H2	Pulley Guard	65	626A286	Blade Shield Assembly
13	626A355	Housing Mount Assembly	66	1567R	Mandrel Plate
14	974R	Blade Clutch Spring (For when lever is on mower)	67	786044	Shield
15	4939M	Retainer Spring	2-68	1044R	Blade Safety Drive Washer
16	957R	Pivot Shaft	69	759R	Mower Housing
17	1563R	V-Belt <i>Granger</i>	70	2464R	Blade
18	2259R	Spring Clip <i>B47 1A106</i>	71	9914M	Spring Washer
19	2292R	Rivet Pin <i>348 3x474</i>	72	539P	Nylock Nut 5/8-18
20	2547R	Mower Clutch Cable	73	968R	Blade Shield Outlet
21	2895H	Handle Grip	74	4524P	Sq. Hd. Set Screw C.P. 3/8-16 x 1/4
22	2503P	Cotter Pin 3/32x 3/4	75	626A373	Lift Link Weldment
23	1053R	Decal	76	1577P	Washer 17/32 x 1-1/16 x 13 Ga.
24	626A360	Lifter Arm Assembly	77	2308R	Bell Crank
25	626A336	Lever Plunger & Button	78	1513P	Washer 13/32 x 13/16 x 16 Ga.
26	2540R	Clutch Cable Anchor	79	2511P	Cotter Pin 3/16 x 1
27	3091P	Hex Bolt 3/8-16 x 1 H.T.	80	626A357	Lifter Arm and Tube
28	1004P	Lockwasher 3/8	81	508P	Hex Jam Nut 3/8-16
29	2876H	Lifter Spring	82	8720H	Pivot Link Rear
30	9465M	Roll Pin 3/16 x 1 1/2	83	5086H	Lifter Bracket
31	2505P	Cotter Pin 1/8 x 3/4	84	501P	Hex Nut 3/8-16
32	626A358	Connecting Link Assembly	85	5000P	E-Ring Truarc 5133-75
33	4940M	Retainer Spring	86	545P	Crown Locknut 3/8-16
34	3848R	Runner L.H.	87	1557P	Washer 13/32 x 13/16 x 11 Ga.
35	3199P	Hex Bolt 3/8-24 x 2 3/4	88	1003P	Lockwasher 5/16
36	1556P	Washer 13/32 x 7/8 x 14 Ga.	89	504P	Hex Nut 5/16-18
37	7375H	Bushing	90	1537P	Washer 11/32 x 11/16 x 16 Ga.
38	9536H	Wheel, Gauge	A	3137P	Hex Bolt 3/8-16 x 1 1/4 Grade 5 H.T.
39	626A283	Wheel Bracket Assembly L.H.	B	3159P	Hex Bolt 5/16-18 x 7/8
40	1004P	Lockwasher 3/8	C	3223P	Slotted Rd. Hd. Mach. Screw 3/8-16 x 3/4
41	515P	Hex Nut 3/8-24	D	16P	Carriage Bolt 5/16-18 x 3/4
42	626A342	Control Arm Assembly	E	3023P	Hex Bolt 3/8-16 x 1
43	2510R	Spacer	F	17P	Carriage Bolt 5/16-18 x 1
44	3827R	Model Plate	G	17P	Carriage Bolt 5/16-18 x 1
45	2537R	Spring (For when lever is on tractor)	H	16P	Carriage Bolt 5/16-18 x 3/4
46	626A372	Idler Bracket Assembly	--	3828R	Owners Manual and Parts List
47	548P	Hex Jam Nut 3/8-24			
48	3382R	Decal			
49	1342R	Idler Pulley			
50	3257P	Hex Bolt 3/8-24 x 1 1/4			
51	1545P	Washer 17/32 x 1 x 16 Ga.			
52	5002P	E-Ring Truarc 5133-50			
53	4379H	Shift Handle Grip			

Sears

**owners
manual**

The Model Number will be found on a plate attached to the L.H. side of the housing mount assembly. Always mention the Model Number when requesting service or repair parts for your 38" Rotary Mower.

All parts listed herein may be ordered through SEARS, ROEBUCK AND CO. or SIMPSONS-SEARS LIMITED. When ordering parts by mail, selling prices will be furnished on request or parts will be shipped at prevailing prices and you will be billed accordingly.

WHEN ORDERING REPAIR PARTS, ALWAYS GIVE THE FOLLOWING INFORMATION AS SHOWN IN THIS LIST.

1. The PART NUMBER
2. The PART DESCRIPTION
3. The MODEL NUMBER
917.252031
4. The NAME OF ITEM—
Rotary Mower



When you buy merchandise from Sears you get an extra something that nobody else can offer . . . Sears Service.

Across town or across the country, wherever you live or move in the U.S.A., Sears Service follows you, providing trustworthy, competent service technicians using only Sears specified factory parts.

**SEARS SERVICE
IS AT YOUR SERVICE
WHEREVER YOU LIVE
OR MOVE
IN THE U.S.A.**

**Sears, Roebuck and Co., Chicago, Ill. 60607 U.S.A.
and Simpsons Sears Limited, Toronto**