

# assembly and operating instructions

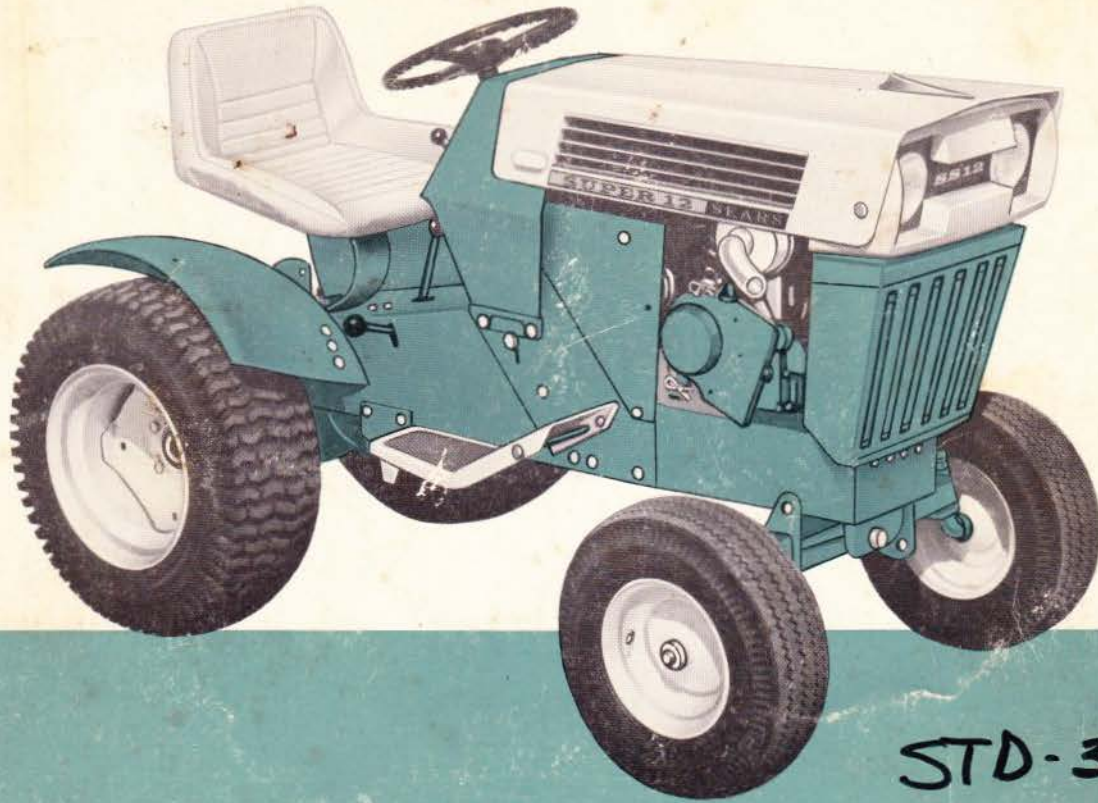

STD-325000

Sears

## Super 12 Tractor

SEARS, ROEBUCK AND CO.....U.S.A.  
SIMPSONS-SEARS LIMITED.....CANADA

## TABLE OF CONTENTS

DESCRIPTION	PAGE NO.	DESCRIPTION	PAGE NO.
Rules of Safety	2	Seat Position	8
Parts Identification	3	Belt Adjustment	9
Setting Up Instructions	4	Brake Adjustment	9
Battery Installation	4	Park Brake Lock	9
Operating Controls	4	Battery Care – Important	10
Before Starting Engine	5	Winter Care	10
To Start Engine	5	Tires	10
To Operate Tractor	6	Storage Instructions	10
Safe Operation	6	General	10
Engine Pulley Groove To Use		How To Start If Battery Is Low	10
For Your Various Attachments	6	Trouble Shooting	11
Transaxle Lubrication	7	Hard To Start	11
Engine Lubrication	7	Engine Over Heats	11
Lubrication Chart	7	Engine Lacks Power	11
Air Cleaner	7	Rear Wheel Adjustment	12
Starter Generator Belt	8	Suggested Rear Wheel Adjustment	
Wheel Weights	8	For Your Attachment	13
Starter Air Screen	8	Some Of The Many Attachments	
Towing Tractor	8	Available For Your Tractor	14
		Optional Equipment	15

Guarantee

Back Page

# MODEL NUMBER 917.25311

INSTRUCTION BOOK PART NO. 8165H

# RULES OF SAFETY

YOU CAN DO  
MANY JOBS  
EASILY WITH THE  
WIDE VARIETY OF  
ATTACHMENTS

**FIRST**  
BE CAREFUL!



**ALWAYS'S** START IN NEUTRAL!

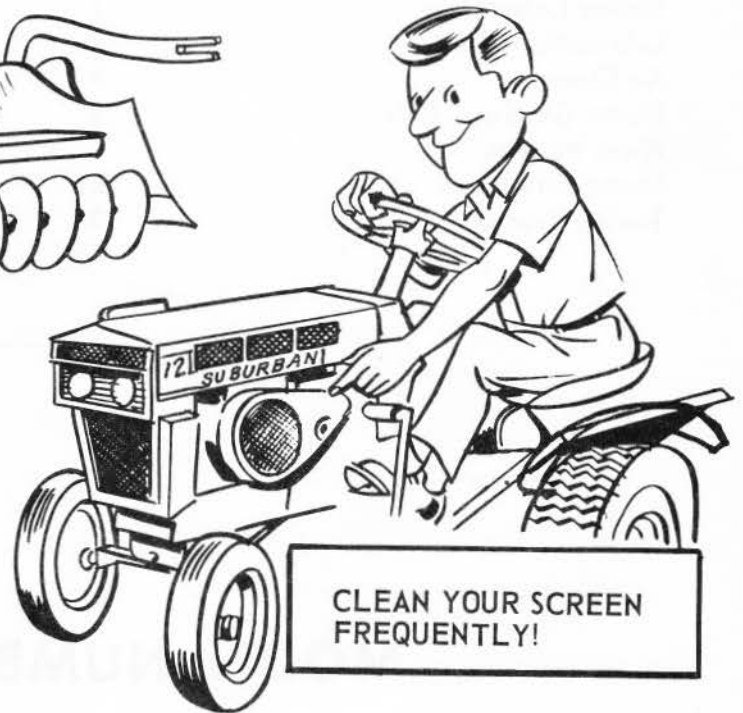
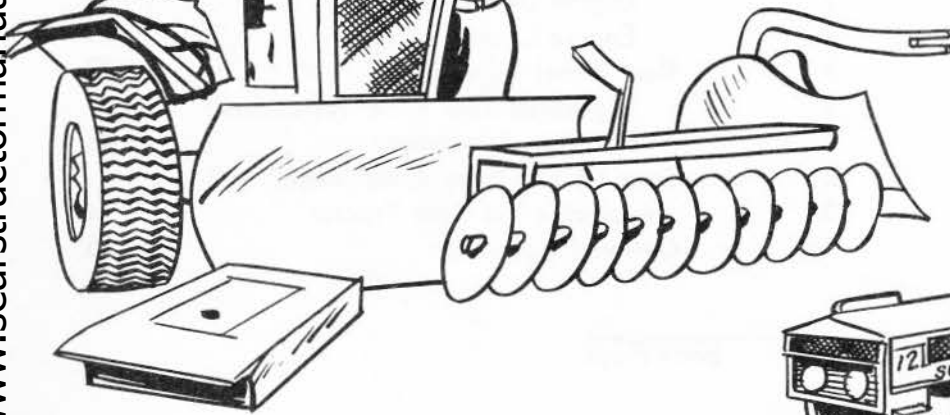

**DO NOT - START, RUN  
OR REFUEL IN A  
CLOSED BUILDING**



**ONLY ONE  
PERSON  
ON TRACTOR**

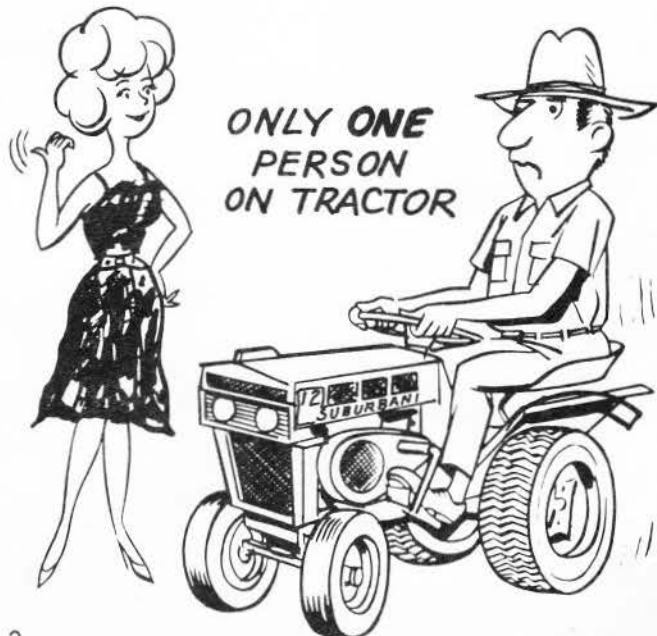



PARTS IDENTIFICATION

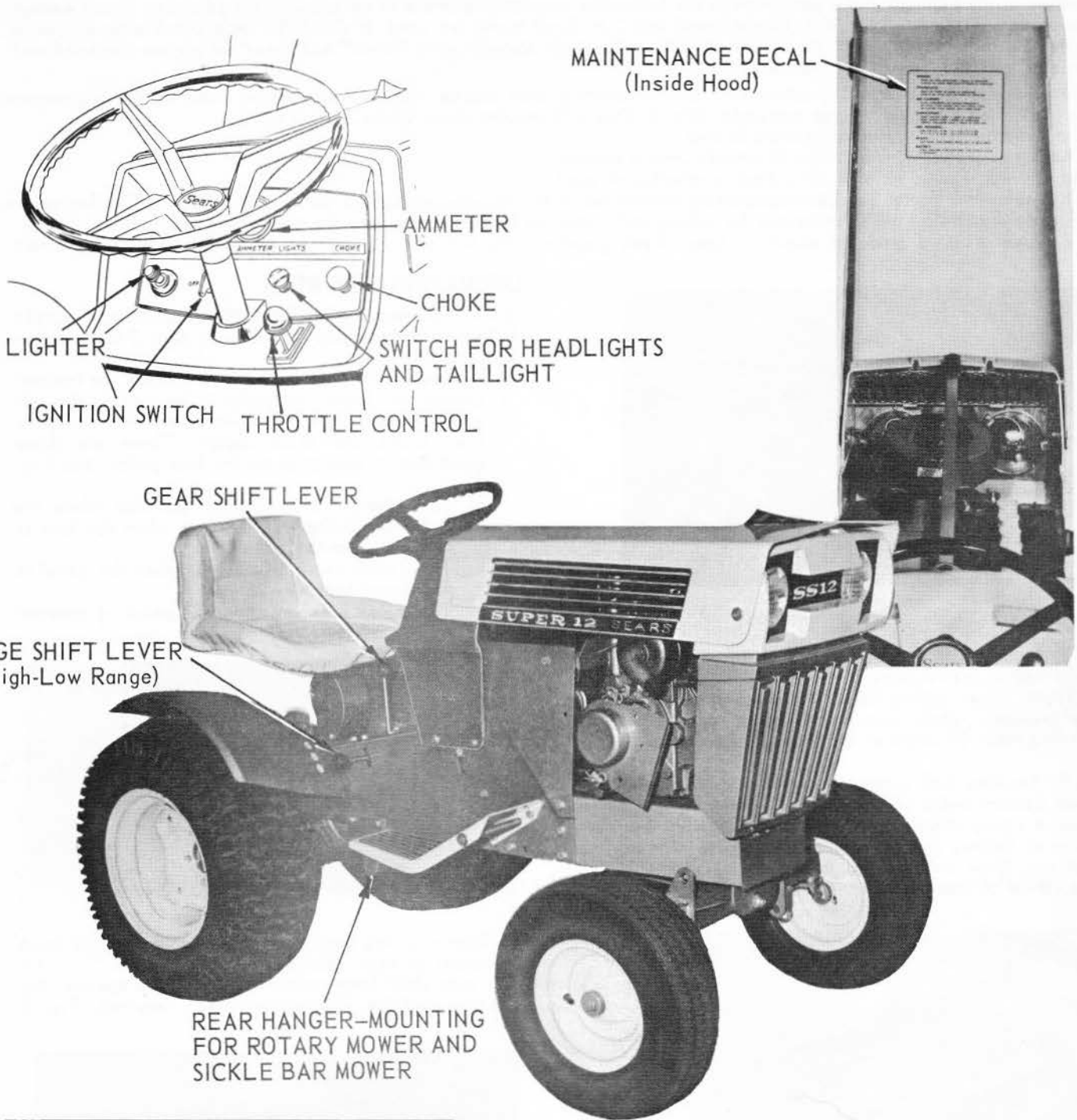

another free manual from www.searstractormanuals.com

FIG. 1

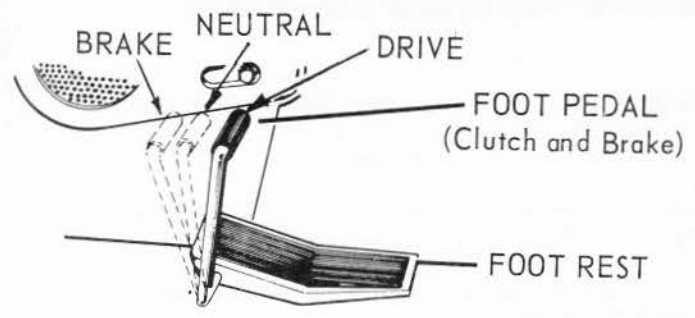

## SETTING UP INSTRUCTIONS

A number at the beginning of a paragraph in the following instructions refers to an arrow in the adjoining figure except when otherwise stated. When R.H. (Right Hand) and L.H. (Left Hand) are used, it should be understood to mean from a position behind and facing the tractor (or direction of travel). Reference to "front" indicates the engine and hood end of tractor, and the "rear" the transmission.

1. Remove carton from around tractor. You have an electric start tractor, remove battery from crate bottom and prepare for operation as given in step one under Fig. 2. This will require about  $2\frac{1}{2}$  to 3 hours of time.
2. Cut banding holding tractor to crate bottom.
3. Check tire pressure, front tires 12 pounds, rear 8 pounds.
4. Adjust rear wheels on axle according to attachment used.
5. This suburban tractor has been completely assembled at the factory, except for battery installation. The battery is shipped dry. Below are instructions for filling and installing battery. Lubricate the tractor and add fuel.

NOTE: Use a good grade of regular, clean, fresh gasoline. Do not mix oil with gasoline. See Lubrication Chart.

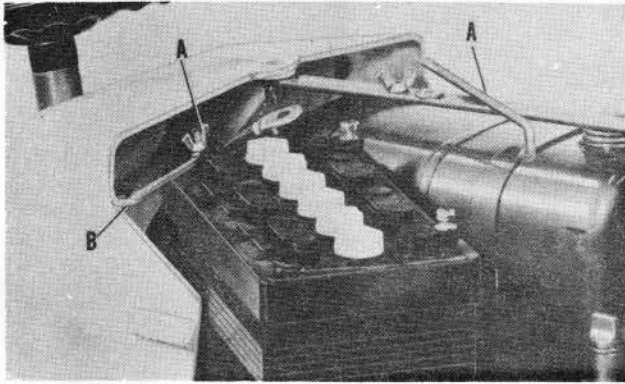

FIG. 2

1. Fill battery with electrolyte and charge battery as outlined in instructions in battery container. CAUTION: After filling cells, let battery stand for thirty minutes. Then charge battery at a rate not exceeding three (3) amperes for about  $2\frac{1}{2}$  hours.
2. Lift cowl and assemble clamp (B) to one of two battery bolts (A). Flat washer and wing nut above clamp. Hook the bolt clamp assembly into rear of battery support and turn clamp to side as shown. Slide battery into position with terminals to center of tractor, as shown in Fig. 2.

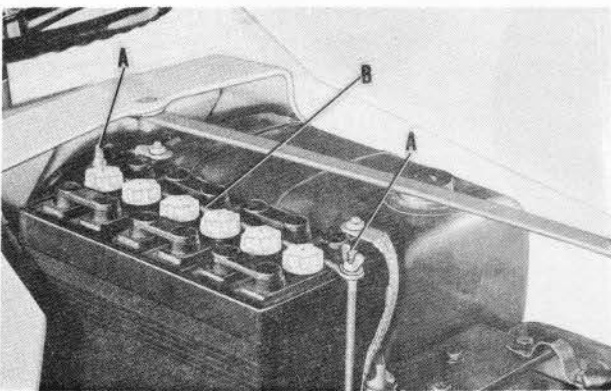

FIG. 3

3. Refer to Fig. 3. Assemble other battery bolt (A) and clamp (B) as shown, with washer and wing nut and tighten wing nut securely.
4. Connect starter switch cable (covered cable) to (+) terminal. Tighten nut securely.
5. Connect ground strap to (-) negative terminal, and tighten nut securely.

## OPERATING CONTROLS

Become thoroughly familiar with the operating controls before starting engine. See Fig. 1, page 3 for location of controls.

The following controls are used to operate the tractor:

1. Clutch and brake foot pedal is located on the left side foot rest. The foot pedal operates a combination brake and drive clutch. There are three positions of operation on the foot pedal. See Fig. 1.
  - a. The clutch is in DRIVE position when the pedal is all the way out (i.e. when the foot is removed from the pedal).
  - b. The clutch is in NEUTRAL when the pedal is depressed half way or more.
  - c. The BRAKE is on when the pedal is pressed all the way forward.

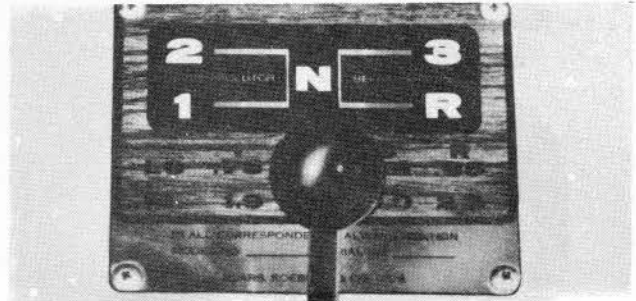

FIG. 4

2. Transmission gear shift lever is located at front center of seat. See Fig. 4.

The gear shift lever selects the Forward speeds, the Neutral, and the Reverse positions required, Fig. 4. and 4.

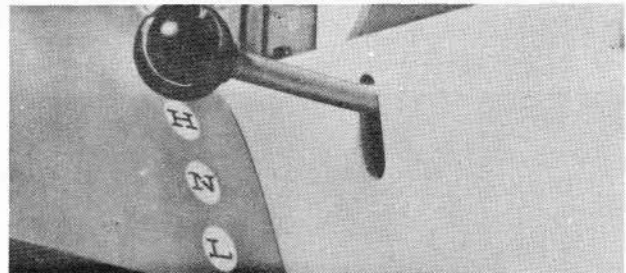

FIG. 5

3. The high-low range is located on R.H. frame side just forward of R.H. rear fender. The high-low range lever has 3 positions, up for high-range, center for neutral, and down for low range. There are two neutral positions in transmission, one on the gear shift lever, and one of the high-low range lever. Both levers must be engaged for tractor to operate. Place gear shift lever in neutral position for starting tractor. Place high-low range lever also in neutral for easier pushing of tractor or when tractor is being towed.

## BEFORE STARTING ENGINE

1. To lift cowling, grasp each side of cowling, at rear and pull outward and upward. Lift cowling to its extreme open position.

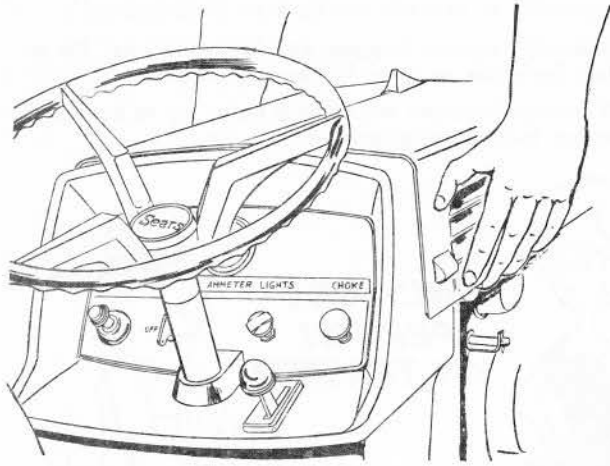

FIG. 6

2. Engine crankcase is shipped with oil ready for use. However check oil level before starting. If necessary, add oil to bring oil level up to the full oil mark on the dipstick. Dipstick must be screwed in tight for checking oil level, and tractor should be level. Oil capacity is 2½ pints. NOTE: Do not fill above full mark on dipstick. Engine must be stopped when checking oil level. Use Allstate Regular M.S. S.A.E. #30 oil or equivalent. If not available, use Allstate Multi-grade all weather oil S.A.E. 10W-20W-30W or equivalent. NOTE: Use S.A.E. 10W oil below 32 degrees.
3. Fill fuel tank with regular grade of clean fresh gasoline, and open fuel shut off valve located near carburetor.

CAUTION: Before starting the engine, check to see that the controls are as follows:

4. Transmission gear shift lever must be in neutral. Neutral is when gear shift lever is free to move forward and backwards. It will operate similar to an automobile. See Fig. 4, page 4.

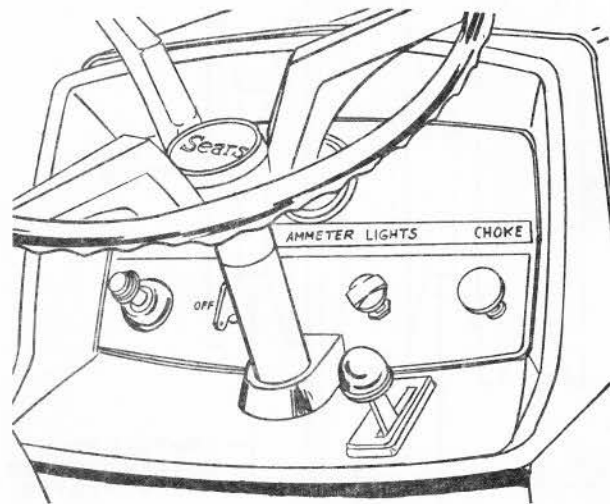
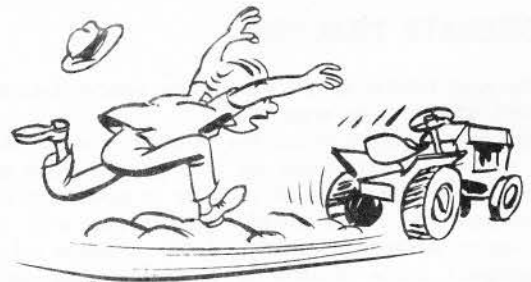

FIG. 7

## TO START ENGINE

1. Pull out choke control to full choke position to start cold engine.



## ALWAYS START IN NEUTRAL!

KEEP ENGINE CLEAN. THIS ENGINE IS AIR-COOLED. IF COOLING SYSTEM BECOMES CLOGGED, SERIOUS DAMAGE MAY RESULT. THEREFORE, KEEP THE BLOWER SCREEN, FINS ON FLYWHEEL, CYLINDER HEAD AND BLOCK FREE FROM GRASS OR DIRT.

2. Advance throttle lever to about ½ throttle.
3. The ignition and starter key is located on L.H. side of dashboard. Turn key clockwise to engage starter. When engine starts, release key. After engine starts push in choke control as engine warms up. Let engine warm up before applying load.

CAUTION: Do not run starter continuously for more than 30 seconds at a time. If after several attempts, engine does not start, move throttle control lever to FAST position. Wait for two minutes and try again.

4. After engine starts, move engine control lever to FAST position.
5. To stop engine turn key in a counter-clockwise direction to off position. Key can be removed so children cannot start tractor.

**DO NOT - START, RUN OR REFUEL IN A CLOSED BUILDING**





## TO OPERATE TRACTOR

1. Try your tractor in a large, open space. Learn to start, stop and reverse.
2. Start the engine and put the throttle lever at about 1/2 throttle. Push down on foot pedal, move gear shift lever and range shift lever to speed desired. Release foot pedal slowly, and tractor will start to move. After foot pedal is fully released (clutch engaged), move throttle lever to fast position. If ground travel is too fast, depress foot pedal and shift to a slower ground travel speed. Always select a ground travel speed so that engine is not overloaded.
3. Do not shift gears while tractor is moving.
4. To stop tractor, push foot pedal all the way down, move gear shift lever to neutral, set park brake lock and release foot pedal. Always check to make sure brake lock will hold tractor secure. Shut-off and remove key from switch. This will prevent unauthorized operation. Never leave engine running with tractor unattended.

3. Do not shift gears while going up steep hills. Choose a low enough gear to climb hill without stopping and shifting gears. If it is necessary to stop while going up hill, do so quickly to prevent tractor rolling backward. Before starting tractor in motion going uphill, use one of the lowest gears, reduce engine speed and engage clutch gradually to prevent tractor from "rearing up".
4. Sideways upsets happen easily in ditches. Be alert for holes or other hidden hazards.
5. If tractor becomes mired in a hole, try to back out rather than driving forward.

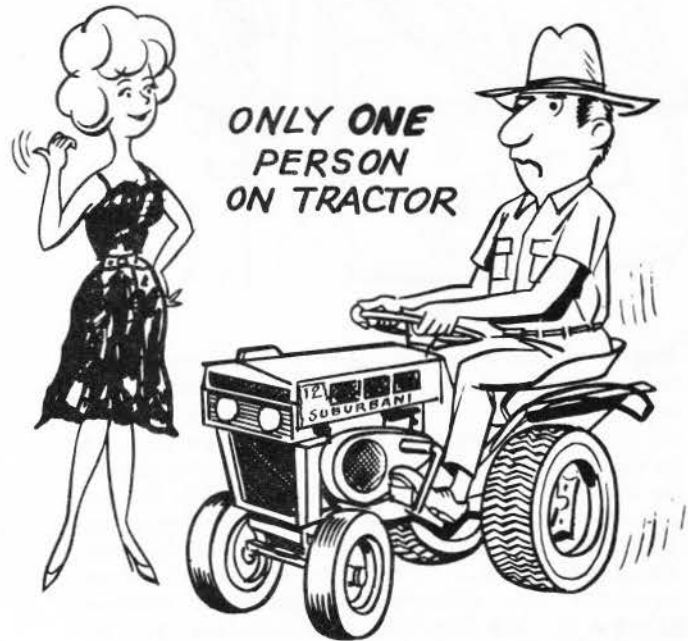

## SAFE OPERATION

1. For greater stability, move both rear tractor wheels so that wheel hubs are flush with ends of axle. Refer to "Rear Wheel Adjustment", page 12.
2. Do not operate the tractor in high gear going down hill, and do not turn sharp corners while going down hill. If it is necessary to stop tractor while going down hill, do so quickly to prevent tractor from picking up speed during the declutching to brake position.

NOTE: The engine produces considerable braking action when throttled back to idling speed without declutching, and this procedure is recommended before applying brake.

DO NOT DECLUTCH GOING UP OR DOWN HILLS—

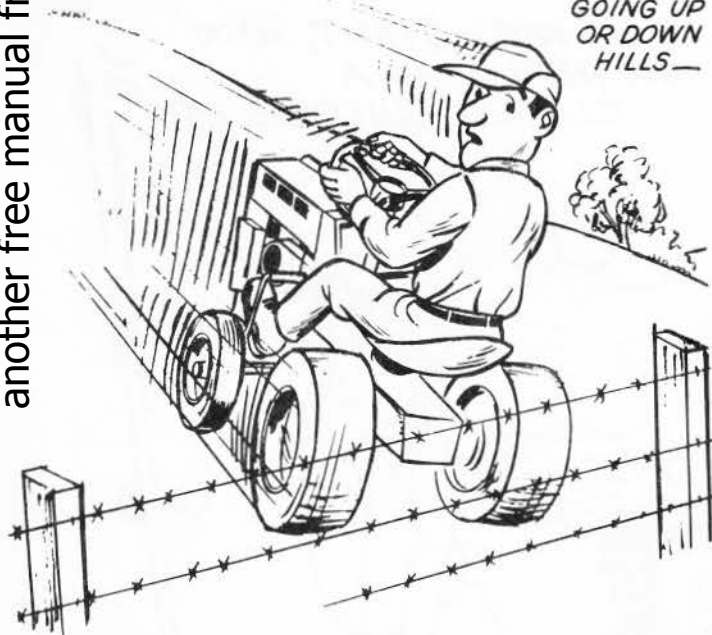

## ENGINE PULLEY GROOVES TO USE FOR YOUR VARIOUS ATTACHMENTS

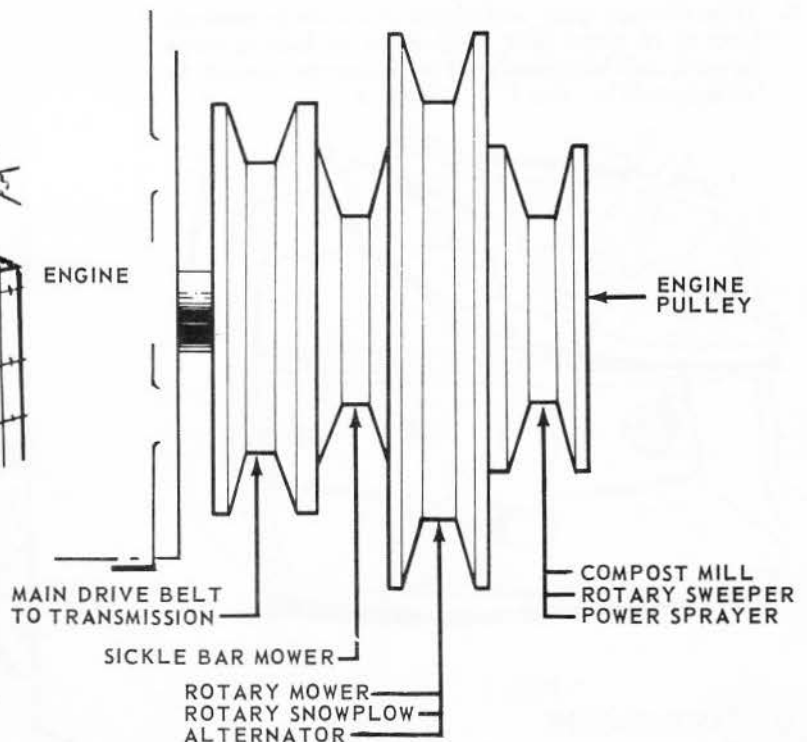

MAJOR REPAIRS SHOULD NOT BE ATTEMPTED UNLESS YOU HAVE THE PROPER TOOLS AND A THOROUGH KNOWLEDGE OF THIS MACHINE.

FIG. 8

## TRANSAXLE LUBRICATION

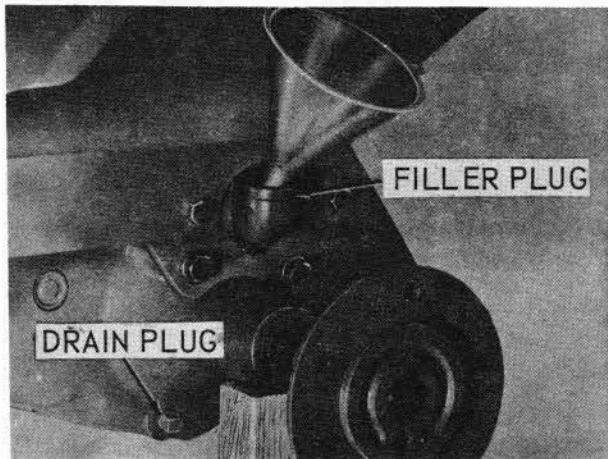

FIG. 9

Rear wheel is removed for illustrating.

1. Check oil in transaxle every 50 hours of operation. To check oil level, remove filler plug (Fig. 9), from transaxle. Oil level should be even with this plug.
2. Change oil in transaxle after 500 hours of operation. To drain, remove drain plug as shown above and catch oil in suitable container.
3. To fill transaxle, use 5 qts. of Allstate S.A.E. 30 motor oil for service MM or MS or equivalent. Fill through filler plug as shown in Fig. 9.

## ENGINE LUBRICATION

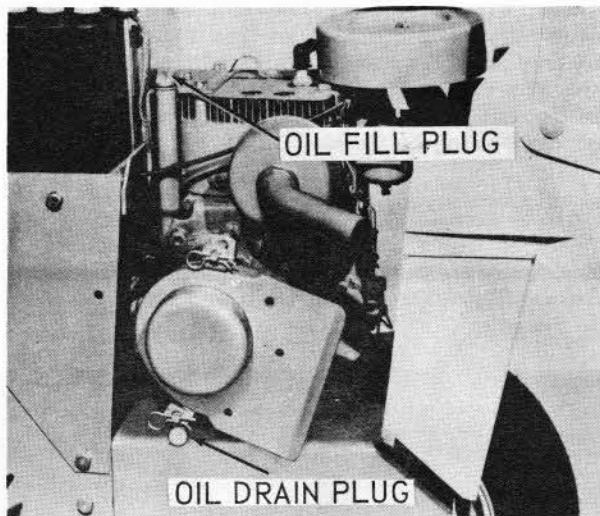

FIG. 10

1. Change oil in crankcase after first 2 hours of operation. Engine should be warm when oil is changed.
2. To drain oil, unscrew pipe plug at lower R.H. side of engine, see Fig. 10. Catch oil in suitable container.
3. Refill engine crankcase with oil as instructed under "Before Starting the Engine". Check oil level after each five hours of operation and add oil, if necessary, to bring to correct level.
4. After first oil change, oil should be changed after each 25 hours of operation.

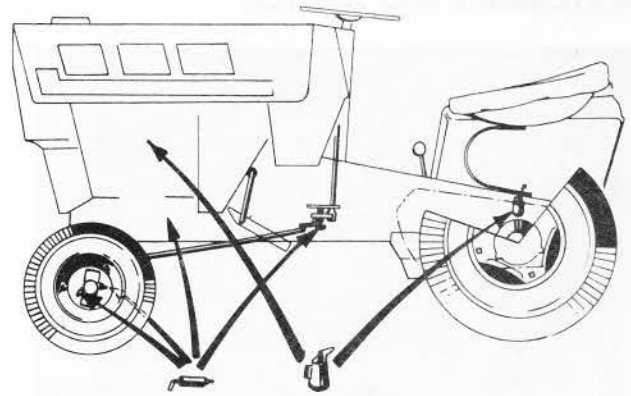

FIG. 11

## LUBRICATION CHART

There are only 5 grease fittings on this tractor:

1. Grease front spindles and wheels every five hours. Two shots of grease each fitting.
2. Grease steering sector every 5 hours, two shots of grease.
3. Check oil in engine crankcase at least every 5 hours of operation. Change oil every 25 hours of normal operation. In extremely dirty or dusty conditions change oil every 15 or 20 hours of operation.
4. Check oil in transaxle every 50 hours of operation. Change oil in transaxle every 500 hours of operation.
5. Apply several drops of oil to all pivot points every 5 hours of operation.

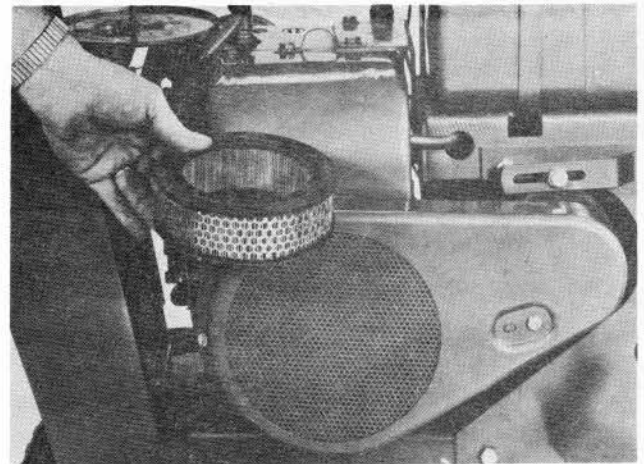

FIG. 12

## AIR CLEANER

Clean air cleaner periodically. To clean carburetor air cleaner remove wing nut that holds air filter cover to bracket and remove cover.

1. Pull element from bracket.
2. Tap element, lightly on a flat surface to dislodge any dirt etc. which has accumulated on element. Compressed air may also be used to clean air cleaner. Blow air from center to outside. This is a dry type air cleaner, so do not oil or wash in gasoline or other solvent.
3. Clean cover and bracket and replace element. Be sure it is seated properly. Wing nut must be kept tight. If air cleaner becomes too dirty, engine will not receive sufficient air to run properly. At the start of each season it is recommended that a new element be installed.



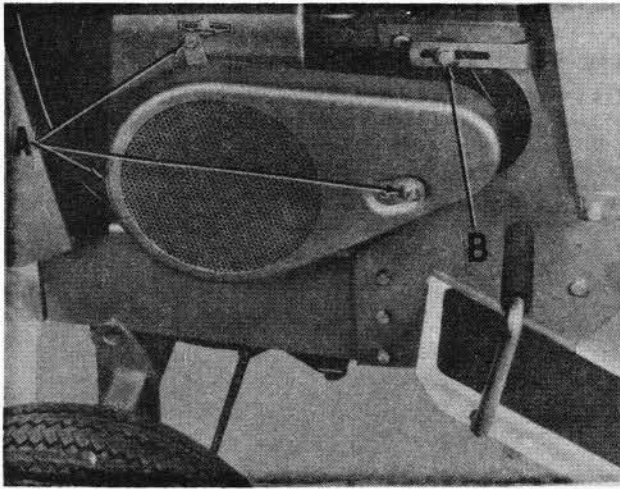

FIG. 13

STARTER GENERATOR BELT

1. Remove 3 screws (A) holding belt guard to engine.
2. Loosen bolt (B) in generator adjusting strap and generator, move starter generator back to tighten belt and tighten bolt (B) securely. Belt should be tight enough to prevent belt slippage when starting tractor.

NOTE: Belt can be tightened at bolt (B), without removing belt guard. However, belt tension will be easier to check with guard removed.

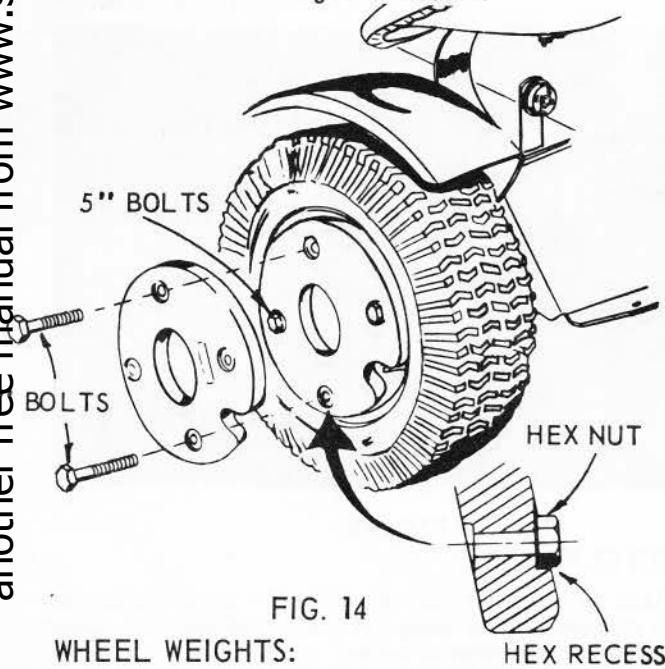
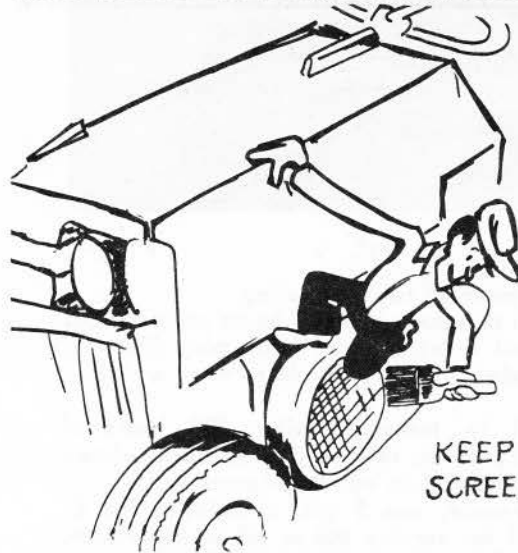

FIG. 14

WHEEL WEIGHTS:

Rear wheel weights (optional equipment) are very essential for added traction. This is especially true for attachments such as the plow, disc harrow, leveler blade, rotary snowplow, bulldozer, etc. One or two wheel weights can be mounted to each rear wheel. Except in the case of the plow (refer to plow attachment manual), wheel weights should be used in pairs, one on each side. Operation with weight on one side only will cause uneven tire wear, may cause the tractor to tip and can result in improper operation of certain attachments.

DO NOT FILL GASOLINE TANK WHILE ENGINE IS RUNNING. AVOID SPILLING GASOLINE ON A HOT ENGINE—THIS MAY CAUSE AN EXPLOSION AND SERIOUS INJURY. DO NOT MIX OIL WITH GASOLINE. USE CLEAN, FRESH "REGULAR" GRADE GASOLINE. FILL TANK COMPLETELY.



KEEP STARTER SCREEN CLEAN

STARTER AIR SCREEN

The starter air screen illustrated in Fig. 13, is designed to keep grass, chaff and large leaves from entering the cooling system and must be cleaned periodically. The cleaning of this starter air screen will vary with the conditions in which the tractor is used. The starter air screen should not be allowed to become too plugged or dirty which would interfere with the cooling of the engine.

TOWING TRACTOR

Place gear shift lever and range lever in neutral position. Tractor can then be towed at a reasonable safe speed.

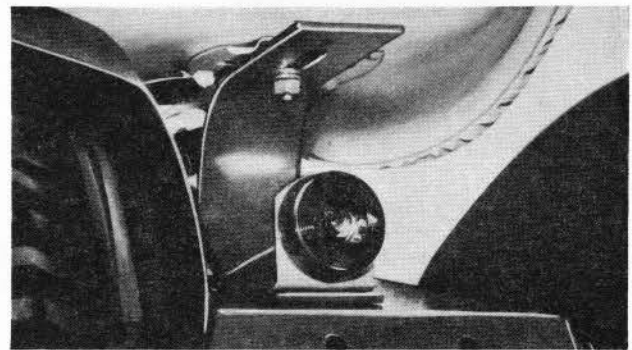

FIG. 15

SEAT POSITION

The seat may be moved towards the front or rear to give the most comfortable riding position. To move the seat, loosen the nut beneath the seat spring and slide the seat to the position required. Tighten the nut making sure that the seat has not twisted out of alignment with the seat spring.

## BELT ADJUSTMENT

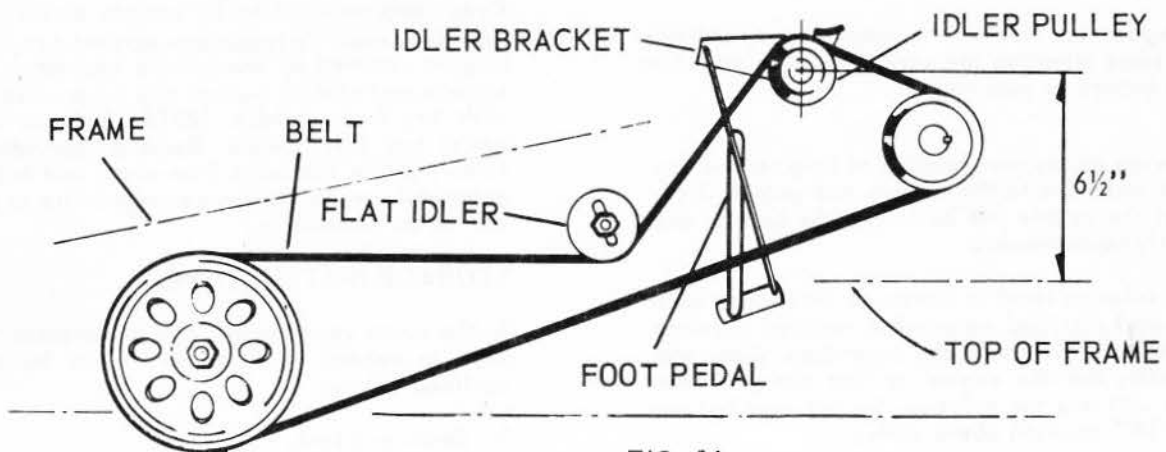

FIG. 16

1. Loosen bolt in flat idler and frame, and push idler and bolt down in slot of frame until center of idler pulley on idler bracket (just back of engine) is 6 1/2 inches above frame as shown. Tighten bolt in flat idler and frame securely.

NOTE: Foot pedal should be in vertical or just back of vertical position with clutch engaged. New belts will stretch after a few hours of operation, then after initial stretch, adjustment is seldom necessary, so adjust belt after first 10 hours of operation.

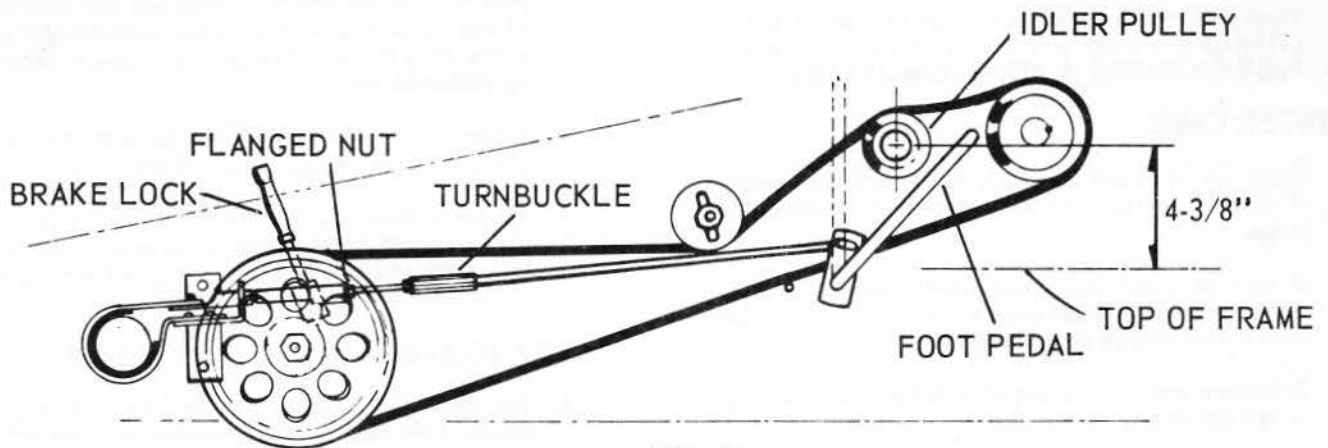

FIG. 17

## BRAKE ADJUSTMENT

To adjust brake, loosen nut back of turnbuckle and turn turnbuckle (clockwise when standing in front of tractor) one turn at a time until foot pedal has about 4 inches of travel from clutch engaged to full brake position, or center of idler is about 4-3/8 above frame as shown.

Tab on idler bracket will deflect belt slightly. Tighten jam nut against turnbuckle to lock turnbuckle in position. Keep brake properly adjusted especially in hilly terrain.

## PARK BRAKE LOCK

The flanged nut is adjustable forward or backward on rear brake rod so that lock assembly will hold brake full on when parking lock is pulled up (lock position). Tighten jam nut against flanged nut to lock flange nut in position. As brake band wears, flanged nut will have to be readjusted.

## IMPORTANT BATTERY CARE

Proper attention to the battery on units so equipped is of the utmost importance.

The battery in your tractor is a special type, and must have the same attention the service station attendant gives the battery in your car.

The following points are recorded to help remind you to provide attention to the battery and gain full advantage of the usable life built into the battery and avoid costly replacements.

1. Check solution level in battery at least once each week. Add distilled water when required to retain the level of 3/16" over the separators. After adding water, run the engine so that the generator charge will mix the solution. Do not over fill - retain 3/16" solution above plates.
2. Keep the battery clean. Remove any collection of grease or other substance from the top of the battery.
3. Keep top of battery clean and dry at all times.
4. Keep battery snug in its cradle or holder.
5. Keep vent caps tight and small vent holes in caps open.
6. If battery should become discharged or fall below a specific gravity of 1.225 remove battery and have it recharged.
7. When recharging, request service station to **SLOW CHARGE** the battery at a rate of 2 or 3 amperes. **FAST CHARGING IS NOT RECOMMENDED.**

## WINTER CARE

1. If unit is not used regularly during winter months it should be removed and stored in a cool, dry place.
2. If unit is used only infrequently during winter months check at least once each thirty days to be sure a full charge is maintained.
3. A battery not fully charged can freeze, resulting in the necessity to replace.
4. A safe rule is to charge the battery monthly or at least test and recharge if below 1.225 specific gravity.

Please remember the necessity of proper winter care for the battery. Batteries not in use for several months and not kept fully charged produce a sulphation of the plates which cannot be removed by recharging.

Your guarantee is intended to provide you adequate protection. It does not, however, cover recharging or damage resulting from lack of care, freezing or inability to perform after winter or long storage periods without proper attention.

## TIRES

Keep tires inflated to 12 pounds of air in front, 8 pounds in rear. To repair a punctured tire, front wheel may be removed by unscrewing cap screw from front spindle and sliding washer and front wheel complete with tire from spindle. NOTE: Bolt on L.H. front wheel has L.H. treads. Remove rear wheel by unscrewing five hub bolts from wheel and hub. A local automobile repair station can repair tire in same manner as an automobile.

## STORAGE INSTRUCTIONS

In the event your tractor is to be inoperative for periods in excess of 30 days - prepare for storage as outlined below:

1. Drain gas tank.
2. Drain carburetor by allowing engine to run out of gasoline. Then push in drain valve under carburetor bowl to remove all gasoline from carburetor. Evaporating gasoline will leave gum deposits if not drained completely. These deposits make fuel systems inoperative resulting in a hard or non-starting engine when again used.
3. Do not save or store gasoline over winter.

## GENERAL

1. Just as your automobile needs professional mechanical maintenance from time to time, so does your air cooled engine. Cleaning and adjustment of the carburetor and periodic replacement of the spark plug and ignition points is made necessary by **NORMAL** use.
2. Professional air cooled engine service is as close as your nearest Sears Store.
3. A yearly check-up or tune-up by Sears is a good idea to avoid breakdowns or delays --- Do it each fall, then you're ready for spring. We even prepare it for storage for you.

## HOW TO START IF BATTERY IS LOW

1. The quickest and best method is to use jumper cables from your 12 Volt automobile battery to the tractor battery.

**CAUTION:** Be sure to connect jumper cable from (+) positive terminal of automobile battery to (+) positive terminal of tractor battery. Connect remaining jumper cable to negative terminals of both batteries.

If jumper cables are not available, belt guard assembly and starter-generator belt can be removed from engine. A piece of rope about 3 ft. long can be used to start engine. Tie a knot at one end of rope and a piece of wood at the other end of the rope (to use as a handle). Wrap rope around pulley and pull rope sharply to start engine. This method will start engine but will not charge battery. Do not attempt to install belt with engine running. We advise the use of jumper cables or remove and charge battery. If belt has been removed, replace belt and adjust tension properly. Replace belt guard.



## TROUBLE SHOOTING

### HARD TO START

No gasoline in fuel tank or carburetor Fuel strainer, or fuel line clogged.	Fill fuel tank; open fuel shut off valve. Check fuel line, fuel strainer and carburetor. Remove fuel strainer and clean. Clean fuel line and carburetor.
Water in gasoline or old fuel. Spark plug wire off at spark plug.	Drain fuel from tank and carburetor. Refill with fresh clean gasoline. Remove and dry spark plug and reset plug gap. Replace wire on spark plug.
Spark plug dirty	Remove plug, clean and reset plug gap, see engine manual or install new spark plug.
Improperly choked, not fully choked or flooded engine.	Check choke, if not fully choking refer to engine manual. Flooded engine, push in choke, open throttle and crank engine to clear out gas.
Dirty carburetor air filter Carburetor out of adjustment Ignition switch off	Remove air filter and tap to remove dust and dirt, clean with compressed air. Install new air cleaner once each year. Check carburetor adjustment, see engine manual. Turn on ignition key.
Poor ignition	Check points, condensor plug, coil or loose wires.

### ENGINE OVERHEATS

Dirty starter, air screen Check oil level in crankcase. Lean Mixture	Clean screen over starter. Be sure fins on cylinder head and around cylinder are clean. Fill to level indicated on dip stick. Do not over fill engine. Correct carburetor adjustment. See engine manual.
--	--

### ENGINE LACKS POWER

Engine overloaded	Shift to a lower gear or reduce load.
Dirty carburetor or air cleaner. Improper carburetor adjustment	Clean or replace air cleaner. Adjust carburetor see Engine Manual.
Faulty ignition Poor compression	Check points, spark plug, condensor, coil and for loose wires. Contact Sears to check compression.
Belt slips	Tighten drive belt.

## REAR WHEEL ADJUSTMENT

NOTE: Wheel adjustment is very important! Your tractor was shipped with the wheels set-in on the axle. Please adjust according to your usage.

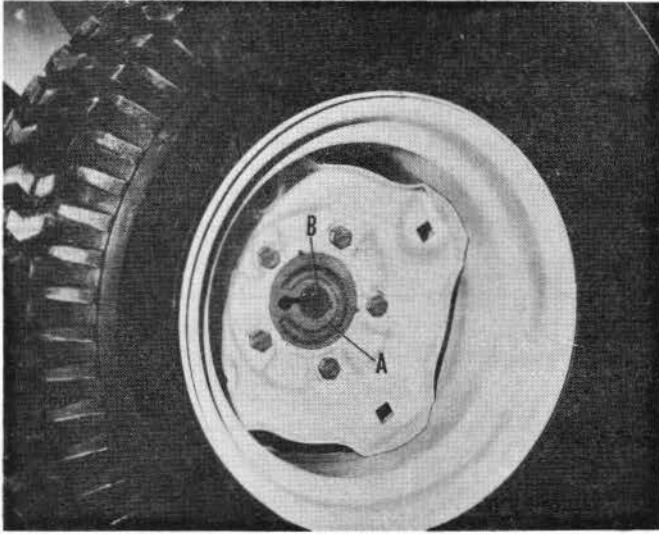

FIG. 18

1. For greater stability on hillsides, move both rear tractor wheels so that wheel hubs (A), are flush with ends of axle (B). Refer to Fig. 18.
2. Refer to Fig. 20. Adjust wheels on axle by loosening jam nut (C), on set screw (D), and then set screw. Also loosen hex bolt (E). Slide wheel in or out on axle as required for attachment, see chart on page 13. Retighten items (C, D, and E) securely.

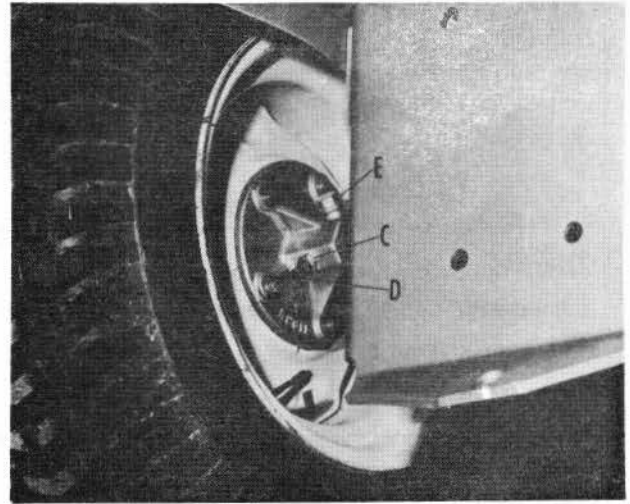

FIG. 20

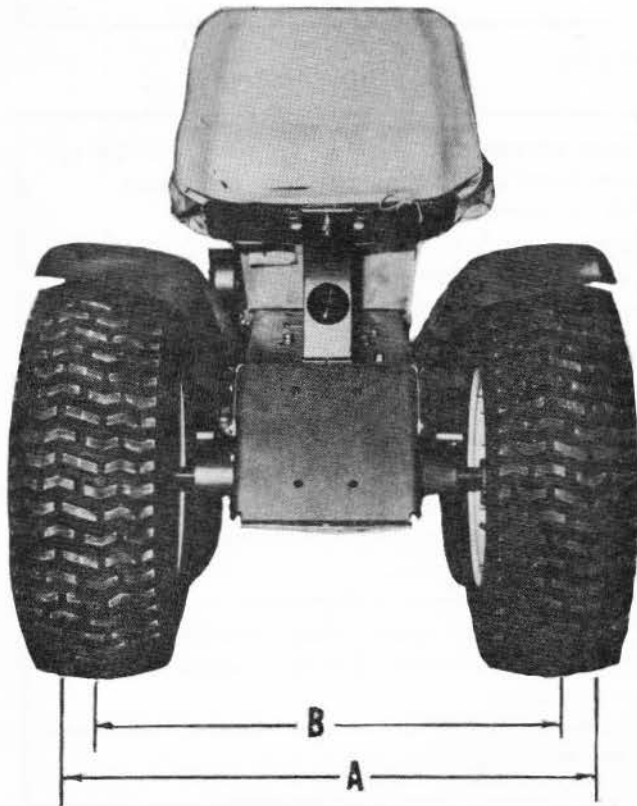

FIG. 19

**A** — MAXIMUM REAR WHEEL TREAD 28"

**B** — MINIMUM REAR WHEEL TREAD 25"  
(Center to center of tire)

SUGGESTED REAR TRACTOR WHEEL ADJUSTMENT FOR YOUR ATTACHMENT

ATTACHMENT	BOTH MOVED OUT ON AXLE AS FAR AS POSSIBLE	BOTH MOVED SO ATTACHMENT COVERS TIRE TRACKS	ADJUST FOR ROW WIDTH
ADJUSTABLE FOOT	X		
ALTERNATOR	X		
COMPOST MILL	X		
CULTIVATOR			X
DISC HARROW	X		
DOZER BLADE		X	
DRAG HARROW	X		
DUMP CART	X		
DUMP RAKE	X		
LAWN ROLLER		X	
LEVELER BLADE	X		
MOWER, REEL	X		
MOWER, ROTARY	X		
MOWER, SICKLE BAR	X		
PLANTER, VEGETABLE			X
*PLOW	X		
SNOWPLOW, ROTARY	X		
SPRAYER, POWER	X		
SPREADER-SEEDER	X		
SWEEPER, ROTARY	X		
TILLER, ROTARY	X		
VACUUM COLLECTOR	X		

NOTE: If at all possible, keep both rear wheels in the outer most position on axle at all times.

\*For detailed instructions, refer to Plow Instruction Book.



SOME OF THE MANY ATTACHMENTS AVAILABLE FOR YOUR SUBURBAN TRACTOR

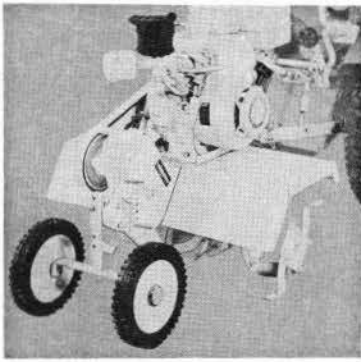

Rotary Tiller

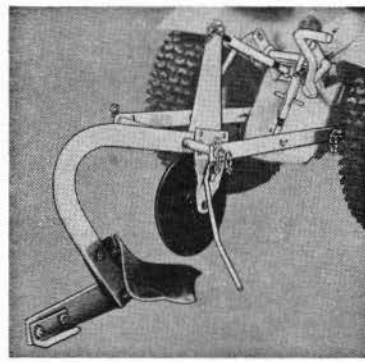

Plow

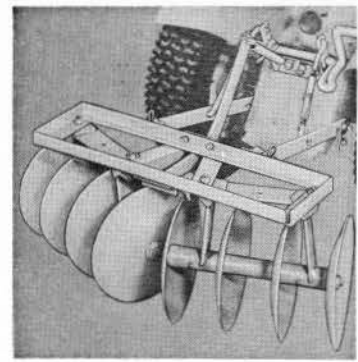

Disc Harrow

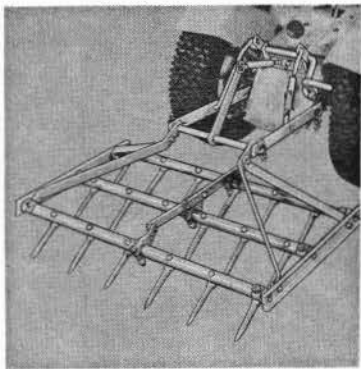

Drag Harrow

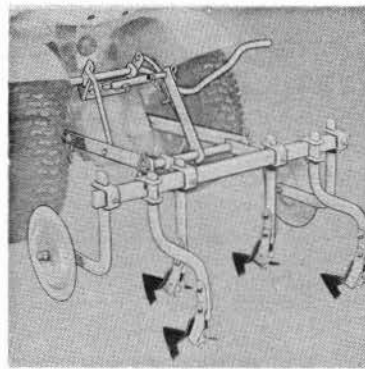

Cultivator with Sweeps

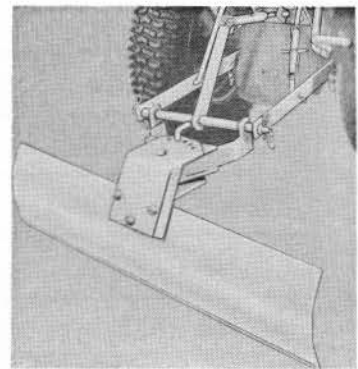

Grader Blade

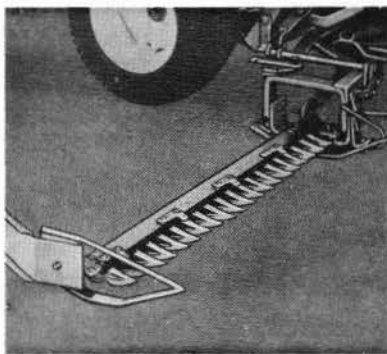

Sickle Bar Mower

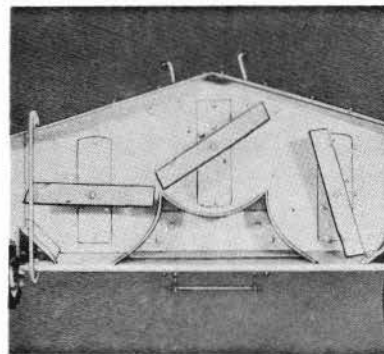

Rotary Mower 42'' or 48''

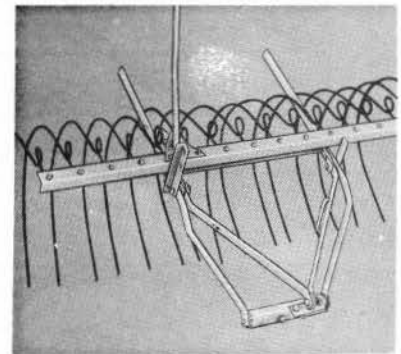

Dump Rake



Bulldozer

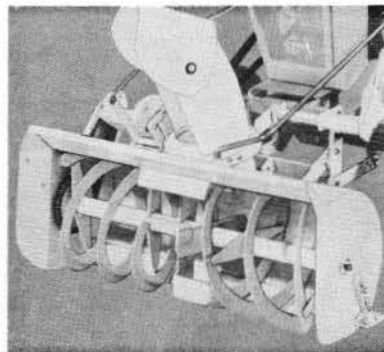

Rotary Snowplow

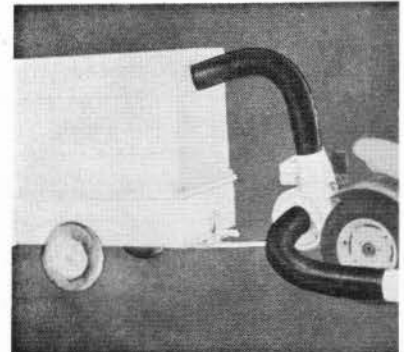

Vacuum Cleaner Attachment

## OPTIONAL EQUIPMENT

### STOCK NUMBER

32-25178  
32-25176  
32-25162

### DESCRIPTION

3 Point Hitch  
Set of Four Hub Caps  
Rear Wheel Weight

634x57

Sears, Roebuck and Co. or Simpsons-Sears Limited in Canada reserves the right to make any changes in design or improvements without imposing any obligation to install the same upon its items heretofore manufactured.



Sears

TRACTOR  
**GUARANTEE**

This Sears Tractor is guaranteed as follows for one year from date of sale:

If repairs or repair parts are required for proper performance, they will be furnished at no cost whatsoever.

Normal maintenance, tune-ups, and failures which are a result of abuse are not included in this coverage.

Tractors equipped with batteries: If battery proves defective and will not hold a charge, in exchange for the battery, we will:

During the first 90 days – replace battery at no charge.

After 90 days – replace battery, charging customer 1/12th of the price of the new battery for each full month from date of sale.

Equipment used for commercial or rental purposes is guaranteed for only 30 days from date of sale.

We do not authorize any person or representative to make any other guarantee or to assume for us any liability in connection with the sale of the Tractor other than those contained herein. Any agreements outside of or contradictory to the foregoing shall be void and of no effect. This guarantee applies only to those machines sold and operated in the United States and Canada.

SEARS, ROEBUCK AND CO.  
and SIMPSONS-SEARS LIMITED



Sears

# SEARS TRACTOR GUARANTEE

ISSUED TO

\_\_\_\_\_  
\_\_\_\_\_  
\_\_\_\_\_

TO THE PURCHASER...

Below space is available to record the serial number, model number, and the date of purchase of your Sears Tractor. We suggest that you record the model number and serial number as this information could be very valuable to you in the future, especially in the case of theft of your tractor, etc. The information also is needed when applying for adjustment under guarantee and also when ordering repair parts.

SERIAL NUMBER

MODEL NUMBER

4/10/68  
DATE OF SALE

REMEMBER...

ONLY SEARS HAS IT

A NATIONWIDE SERVICE ORGANIZATION  
COAST TO COAST  
FACTORY APPROVED PARTS AND  
EXPERT FACTORY TRAINED MEN



## MAINTENANCE AGREEMENT

A modern low cost, full protection Maintenance Agreement is available on this product, coverage up to two full years if desired. No examination necessary if purchased within 30 days of original Tractor purchase. Contact your nearest Sears Store.



*NO. 1... WHERE THE TRRR-ACTION IS!*

