

Sears

**OWNERS
MANUAL**

MODEL NO.
917.253582
42 INCH AND
MODEL NO.
917.253592
48 INCH

**Caution:
Read Rules for
Safe Operation
and Instructions
Carefully**



42 AND 48 INCH ROTARY MOWER

**Assembly
Installation
Operation
Repairs Parts**

CONGRATULATIONS on your purchase of a Sears Rotary Mower. It has been designed, engineered and manufactured to give you the best possible dependability and performance. Should you experience any problem you cannot easily remedy, please contact your nearest Sears, Roebuck and Co. Store. They have competent, well-trained technicians and the proper tools to service or repair this unit.

Please read and retain this manual. The instructions will enable you to assemble, operate and maintain your mower properly. Always observe the "RULES FOR SAFE OPERATION".

**FULL ONE YEAR WARRANTY
ON ROTARY MOWER TRACTOR ATTACHMENT
(EXCLUDING BLADE(S) AND BLADE ADAPTER(S))**

For one year from the date of purchase, when this rotary mower tractor attachment is maintained and lubricated according to the operating and maintenance instructions in the owner's manual, Sears will repair free of charge any defect in material or workmanship.

This warranty excludes blade(s) and blade adapter(s), which are expendable and become worn during normal use.

This warranty does not cover:

- repairs necessary because of operator abuse or negligence, including the failure to maintain the equipment according to instructions contained in the owner's manual; and
- rotary mower tractor attachments used for commercial or rental purposes.

WARRANTY SERVICE IS AVAILABLE BY CONTACTING THE NEAREST STORE OR SERVICE CENTER IN THE UNITED STATES. This warranty applies only while this product is in use in the United States.

This warranty gives you specific legal rights, and you may also have other rights which vary from state to state.

SEARS, ROEBUCK AND CO., Sears Tower, Dept. 698/731A, Chicago, IL 60684

TABLE OF CONTENTS

RULES FOR SAFE OPERATION	1
ASSEMBLY INSTRUCTIONS	2
PRE-USE ADJUSTMENT	5
OPERATING INSTRUCTIONS	6
MAINTENANCE INSTRUCTIONS	7
REPAIR PARTS	11
OPTIONAL EQUIPMENT	
ASSEMBLY OF GAUGE WHEELS	16
GAUGE WHEEL REPAIR PARTS	17

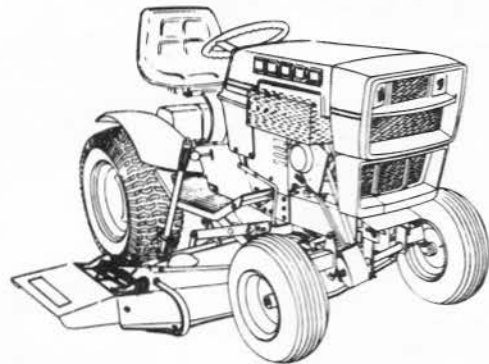

RULES FOR SAFE OPERATION



LOOK FOR THIS SYMBOL TO POINT OUT IMPORTANT SAFETY PRECAUTIONS. IT MEANS--ATTENTION! BECOME ALERT! YOUR SAFETY IS INVOLVED.

1. Know the controls and how to stop quickly. READ THE OWNER'S MANUAL.
2. Do not allow children to operate the vehicle. Do not allow adults to operate it without proper instruction.
3. Do not carry passengers. Keep children and pets a safe distance away.
4. Always wear substantial footwear. Do not wear loose fitting clothing that could get caught in moving parts.
5. Keep your eyes and mind on your tractor, mower and the area being cut. Don't let other interests distract you.
6. Do not attempt to operate your tractor or mower when not in drivers seat.
7. Always get on or off your tractor from the operators left hand side.
8. Clear the work area of objects which might be picked up and thrown.
9. Disengage all attachment clutches and shift into neutral before attempting to start the engine.
10. Disengage power to attachments and stop the engine before leaving the operator's position.
11. Disengage power to mower, stop the engine and disconnect spark plug wire(s) from spark plug(s) before cleaning, making an adjustment or repairs.
12. Disengage power to attachments when transporting or not in use.
13. Take all possible precautions when leaving the vehicle unattended, such as disengaging the power-take-off, lowering the attachments, shifting into neutral, setting the parking brake, stopping the engine, and removing the key.
14. Do not stop or start suddenly when going uphill or downhill. Mow up and down the face of slopes (not greater than 15°); never across the face.
15. Reduce speed on slopes and make turns gradually to prevent tipping or loss of control. Exercise extreme caution when changing direction on slopes.
16. Do not shift gears while going up or down slopes. Choose a gear low enough to negotiate the slope without stopping and shifting gears. To reduce speed, move throttle lever to slow.
17. Never mow in wet or slippery grass, when traction is unsure or at a speed which could cause a skid.
18. Stay alert for holes in the terrain and other hidden hazards.
19. Do not drive too close to creeks, ditches and public highways.
20. Exercise special care when mowing around fixed objects in order to prevent the blades from striking them. Never deliberately run tractor or mower into or over any foreign object.
21. Never shift gears until tractor comes to a stop.
22. Never place hands or feet under the mower, in the deflector (discharge chute) or near any moving parts while tractor or mower are running. Always keep clear of discharge chute.
23. Use care when pulling loads or using heavy equipment.
 - a. Use only approved drawbar hitch points.
 - b. Limit loads to those you can safely control.
 - c. Do not turn sharply. Use care when backing.
 - d. Use counterweight or wheel weights when suggested in this owner's manual.
24. Watch out for traffic when crossing or near roadways.
25. When using any attachments, never direct discharge of material toward bystanders nor allow anyone near the vehicle while in operation.
26. Handle gasoline with care - it is highly flammable.
 - a. Use approved gasoline containers.
 - b. Never remove the cap of the fuel tank or add gasoline to a running or hot engine, or fill the fuel tank indoors. Wipe up spilled gasoline.
 - c. Open doors if the engine is run in the garage - exhaust fumes are dangerous. Do not run the engine indoors.
27. Keep the vehicle and attachments in good operating condition, and keep safety devices in place.
28. Keep all nuts, bolts and screws tight to be sure the equipment is in safe working condition.
29. Never store the equipment with gasoline in the tank inside a building where fumes may reach an open flame or spark. Allow the engine to cool before storing in any enclosure.
30. To reduce fire hazard, keep the engine free of grass, leaves or excessive grease.
31. Except for adjustment; DO NOT operate Engine if air cleaner or cover directly over carburetor air intake is removed. Removal of such part could create a fire hazard.
32. DO NOT OPERATE WITHOUT A MUFFLER OR TAMPER WITH THE EXHAUST SYSTEM. Damaged mufflers or spark arresters could create a fire hazard. Inspect periodically and replace if necessary.
33. The vehicle and attachments should be stopped and inspected for damage after striking a foreign object, and the damage should be repaired before restarting and operating the equipment.
34. Do not change the engine governor settings or overspeed the engine.
35. When using the vehicle with mower, proceed as follows:
 - a. Mow only in daylight or in good artificial light.
 - b. Never make a cutting height adjustment while the engine is running if the operator must dismount to do so.
 - c. Shut the engine off when removing the grass catcher or unclogging chute.
 - d. Check the blade mounting bolts for proper tightness at frequent intervals.
36. Check the grass catcher bags frequently for wear or deterioration. Replace with new bags for safety protection.
37. Do not operate the Mower without either the entire grass catcher, on mowers so equipped, or the deflector shield in place.

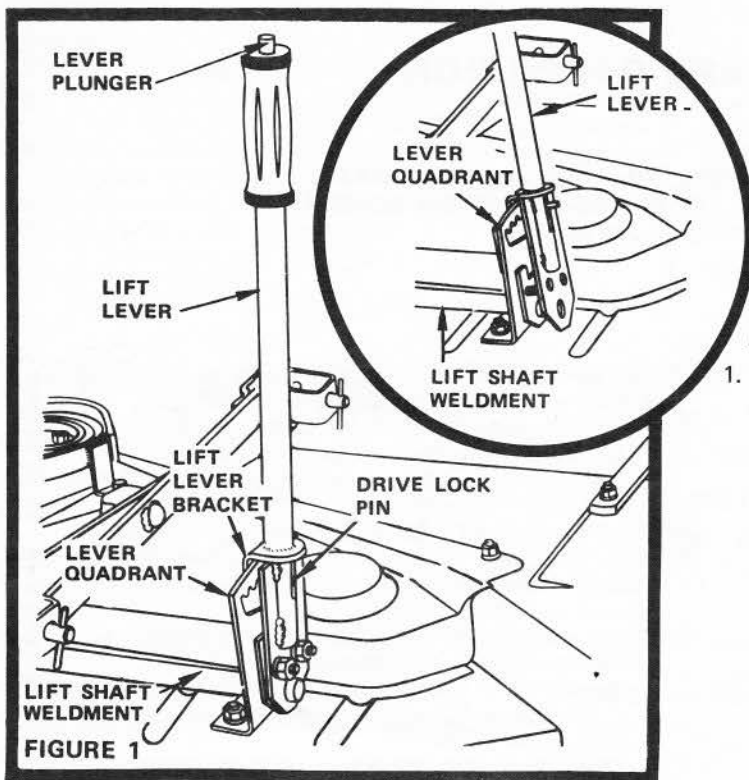

FIGURE 1

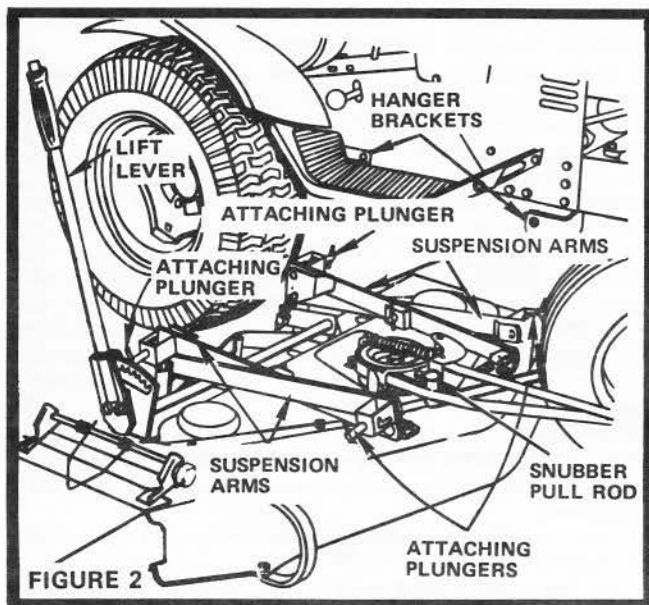

FIGURE 2

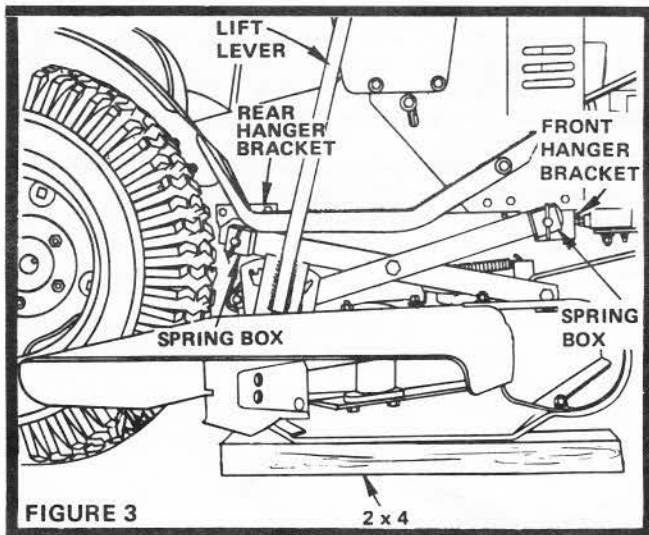

FIGURE 3

To assemble your Mower you will need

a 9/16" Wrench and a Hammer

When R.H. (Right Hand) or L.H. (Left Hand) is used, it means from a position behind the steering wheel as if you were seated on the tractor seat and facing forward.

ASSEMBLY

1. Install Lift Lever using:

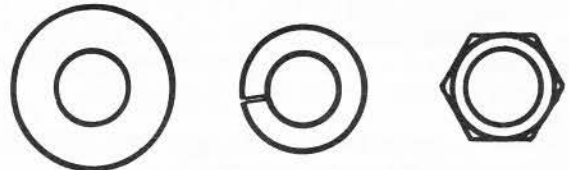

two Flat Washers, two Lockwashers and two Hex Nuts found in bag of parts.

- a. Place Lift Lever (Fig. 1) over Lever Quadrant and tilt bottom of Lever outward to align Bolts in Lift Shaft Weldment with holes in Lever.
- b. Install Lift Lever to end of Lift Shaft Weldment (Fig. 1). Be sure Lift Lever Bracket straddles Lever Quadrant and that Lever fits on end of Lift Shaft. Secure with Flat Washers, Lockwashers and Hex Nuts. Tighten Nuts securely.
- c. Depress Lever Plunger and move Lift Lever to middle of Lever Quadrant. Drive Drive Lock Pin through Lever, Lever Quadrant and Lift Lever Bracket.

ASSEMBLE MOWER TO TRACTOR

1. Check tractor tire pressure for proper inflation.
2. Drive tractor to an area that is smooth and level.
3. Position mower on R.H. side of tractor as shown (Fig. 2).
4. Turn tractor steering wheel to the extreme left.
5. Lock all four Attaching Plungers in the "OUT" position.
6. Move Lift Lever to the extreme rear position.
7. Slide mower under tractor until Suspension Arms are directly beneath Hangar Brackets. NOTE: Be sure end of Snubber Pull Rod is extending to front of tractor and between front wheels.
8. For ease in attaching mower to tractor, place a two foot long 2 x 4 (or similar object) flat wise under each end of mower (Fig. 3).
9. Move Lift Lever to the extreme forward position.
10. Grasp suspension arms by the Spring Boxes. Raise R.H. suspension arms and align with holes in Front and Rear Hanger Brackets.
11. Release front Plunger so that Plunger enters hole in R.H. Front Hanger Bracket.
12. Release rear Plunger so that Plunger enters slot in R.H. Rear Hanger Bracket.
13. Repeat steps 10, 11 and 12 for L.H. side of mower.
14. Pull Lift Lever back to lift mower.
15. Remove Blocks from under each end of mower.

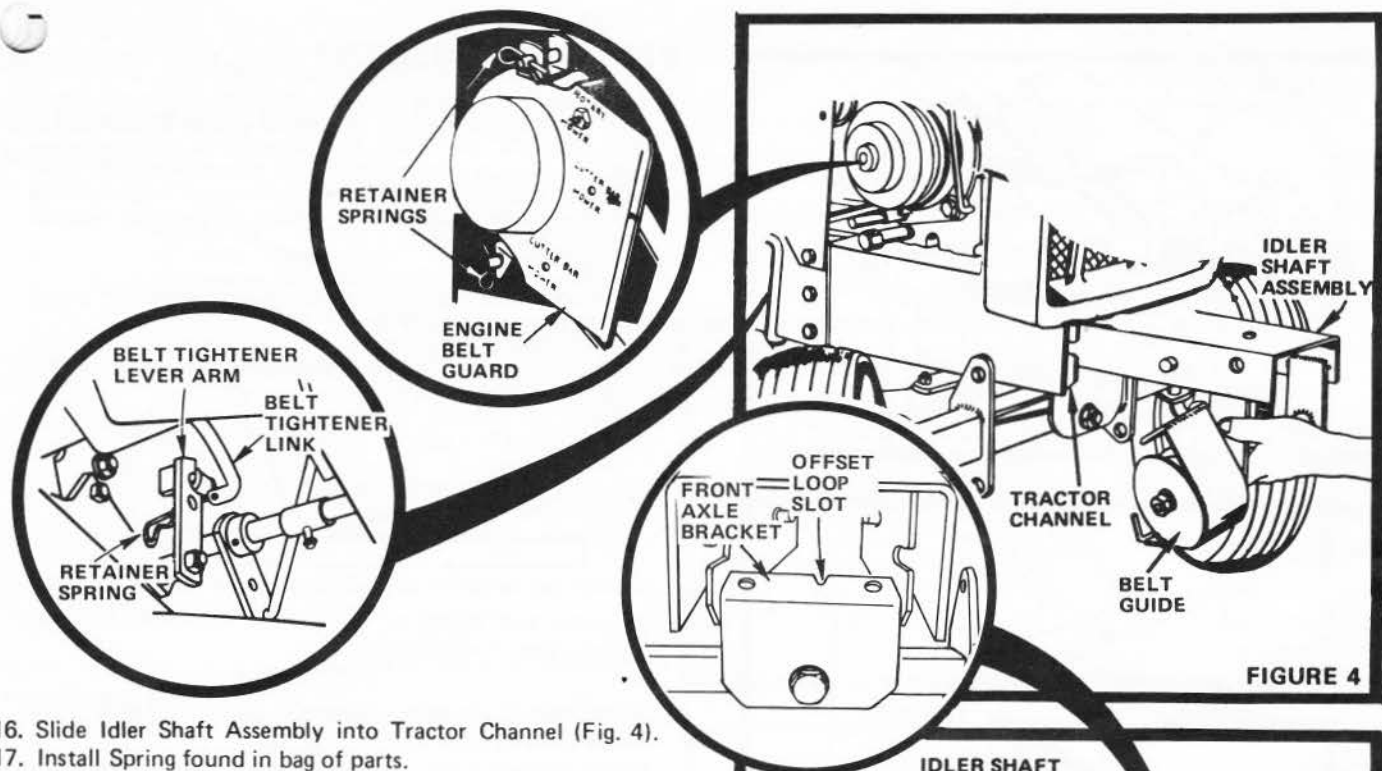
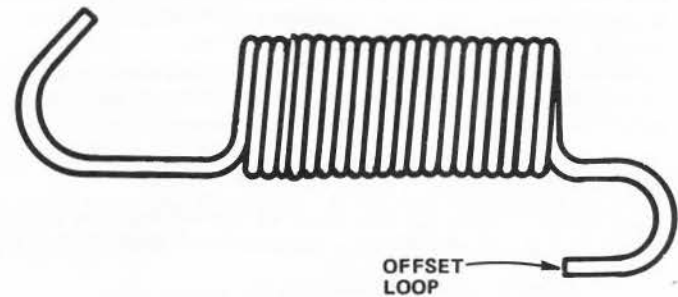

FIGURE 4

- 16. Slide Idler Shaft Assembly into Tractor Channel (Fig. 4).
- 17. Install Spring found in bag of parts.



Hook Offset Loop of Spring into slot in rear of Front Axle Bracket. Hook other loop of Spring in hole in Idler Shaft Assembly (Fig. 5).

- 18. Remove the two Retainer Springs and Engine Belt Guard. (Fig. 4 - inset).
- 19. Remove Nut, Lockwasher and Belt Guide (Fig. 6). Place Belt on Idler Sheaves and on Engine Pulley. NOTE: See Fig. 6 for proper way of installing Belts on Idler Sheaves. Back-side (outside) of Belt must be placed in Flat (outside) Idler. Belt must be placed in largest groove on Engine Pulley.
- 20. Assemble Adjusting Pin found in bag of parts

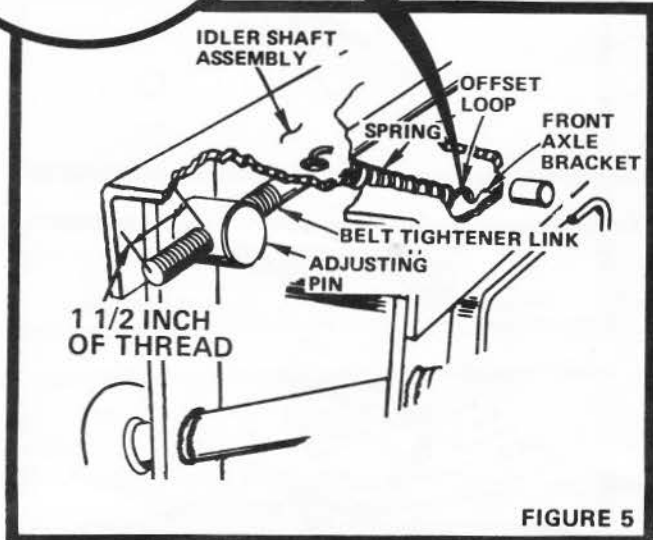
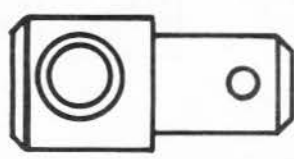

FIGURE 5



to threaded end of Belt Tightener Link (Fig. 5).

- 21. Secure Link to Belt Tightener Lever Arm with Retainer Spring found in Bag of Parts.



Install Belt Tightener Link through opening in Idler Shaft Assembly. Attach bent end of Link to rear end of Belt Tightener Lever Arm. Secure Retainer Spring (Fig. 4 - left hand inset).

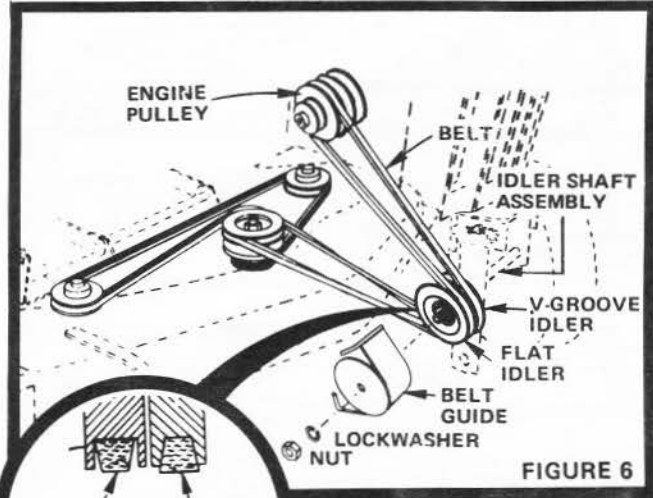

FIGURE 6

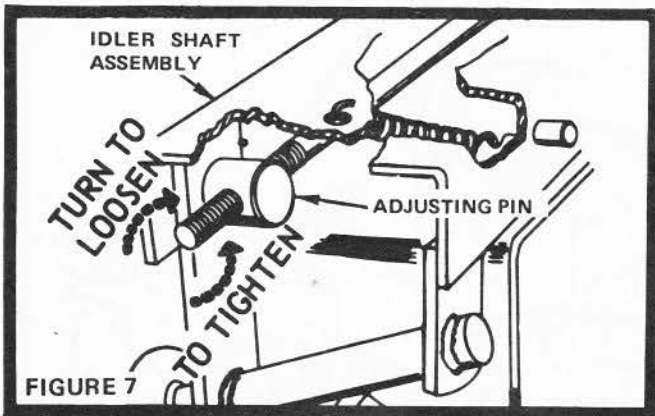

FIGURE 7

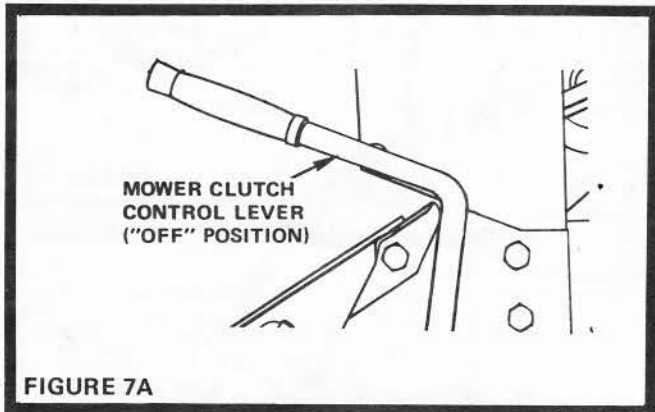

FIGURE 7A

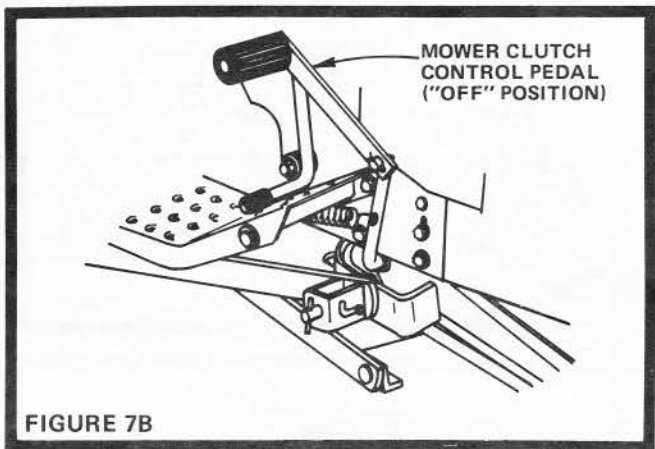

FIGURE 7B

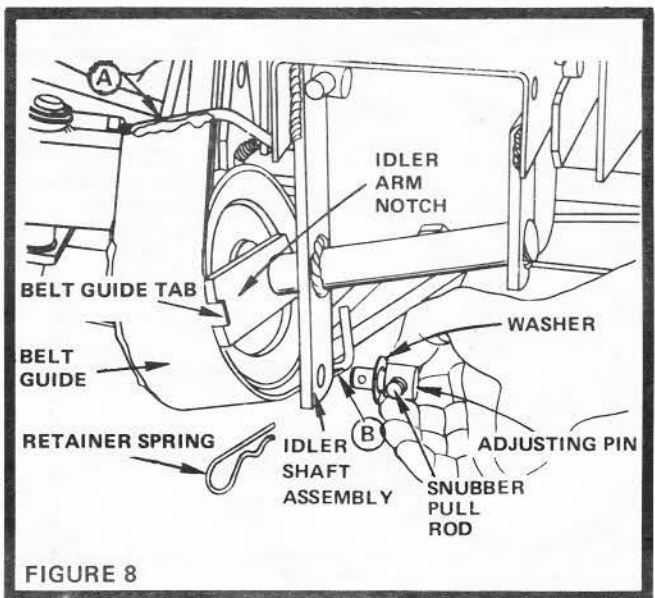
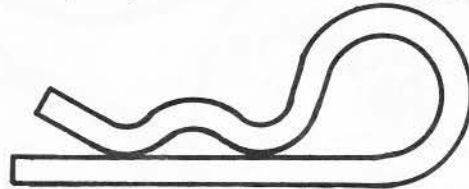

FIGURE 8

BELT ADJUSTMENT

1. Adjust belt by turning Adjusting Pin (Fig. 7) counterclockwise to tighten; clockwise to loosen. Engage Mower Clutch Control ("ON" Position). Belt is properly adjusted when Belt can be squeezed together with thumb and fore finger (without undue pressure) midway between Engine Pulley and Idler Sheaves. After first 2 hours of mowing, recheck Belt for proper tension.
2. Belt from center to outside mandrels is spring loaded therefore no adjustment is necessary.
3. Attach Adjusting Pin to Idler Shaft Assembly using:



one of the large Retainer Springs found in bag of parts.

4. Assemble Belt Guide to Idler Shaft. Position Belt Guide Tab in Idler Arm Notch (Fig. 8).

Secure Belt Guide with Lockwasher and Nut. Tighten Nut securely.

Belt Guide must clear belt by 1/16 to 1/8 inch at points A and B when clutch lever is engaged (belt tight) in both highest and lowest cutting position of mower. If Belt Guide does not clear by 1/16 to 1/8 inch, Belt Guide can be bent slightly at points A and B with pliers or wrench to achieve the proper clearance.

5. Reassemble Engine Belt Guard to engine. Secure with the two Retainer Springs previously removed (Fig. 4).
6. Place Mower Clutch Control Lever in "OFF" Position as shown in Fig. 7A (if Tractor is equipped with Pedal, refer to Fig. 7B).

7. Complete assembly using:

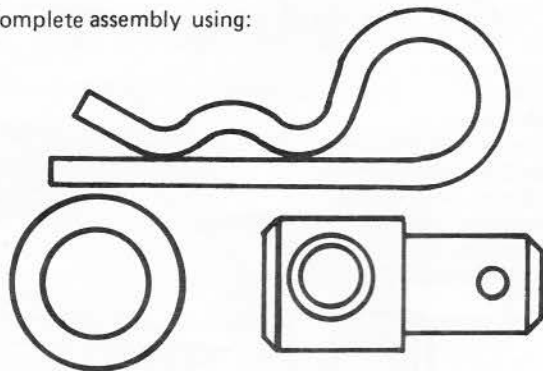

remaining Retainer Spring, Washer and Adjusting Pin found in bag of parts.

- a. Thread Adjusting Pin on Snubber Pull Rod until Adjusting Pin will enter hole in Idler Shaft Assembly (Fig. 8). Remove Adjusting Pin from hole. Turn Adjusting Pin counterclockwise 6 complete turns and slip Washer on Pin. Insert Pin in Idler Shaft Assembly. NOTE: Mower Clutch Control can be pushed ahead to assemble. Secure with Retainer Spring.

When Mower Clutch Control is fully disengaged ("OFF" Position) blades will stop quickly.



MAKE SURE THAT BRAKE IS NOT AGAINST MANDREL PULLEY WHEN MOWER IS ENGAGED (LEVER OR PEDAL PUSHED FORWARD TO "ON" POSITION).

8. If Snubber Pull Rod is ever removed, be sure it is reassembled as shown in Fig. 9 to Snubber Weldment and secured with Cotter Pin. NOTE: SNUBBER PULL ROD MUST BE POSITIONED UNDER MOWER DRIVE BELT WITH SLIGHT BEND IN ROD DOWNWARD.

PRE-USE ADJUSTMENT

LEVEL MOWER FROM SIDE TO SIDE



PLACE THE MOWER CLUTCH CONTROL IN THE "OFF" POSITION, LOCK THE PARKING BRAKE, SHIFT INTO NEUTRAL, SHUT OFF THE ENGINE. MAKE ABSOLUTELY SURE THE BLADES AND ALL MOVING PARTS HAVE COMPLETELY STOPPED, REMOVE THE IGNITION KEY, DISCONNECT THE SPARK PLUG WIRE(S) FROM THE SPARK PLUG(S) AND KEEP WIRE(S) AWAY FROM THE PLUG(S) TO PREVENT INJURY FROM ACCIDENTAL STARTING.

1. Depress Lift Lever Plunger. Move Lift Lever to approximately the middle of notched Lever Quadrant.
2. Rotate outer blades so that they are in line with width of the tractor.
3. Measure the height of the tips of outer blades (Fig. 10). Both R.H. and L.H. must be the same distance from level surface within 1/8 of an inch.
4. If an adjustment is required, adjust Nut on Hanger Link at L.H. side (Fig. 11) to level mower. Shorten Link to raise L.H. side of mower. Lengthen Link to lower L.H. side of mower.

ADJUST MOWER FROM FRONT TO REAR

1. Your mower should cut approximately 3/16" lower at front than at the rear. With R.H. mower blade in line with length of tractor, measure the height of the front tip of blade (Fig. 10). Rotate blade 1/2 turn and measure. The front tip must be approximately 3/16 of an inch lower at front than at rear.
2. Adjusting Leveling Pin Nuts (Fig. 11) up or down to obtain the above pitch or difference from front to rear. Adjusting the Nuts up will raise the rear of the mower. Lowering Nuts will lower rear of mower. Tighten the two Nuts securely against Leveling Pin.

LUBRICATION

Mandrels are shipped lubricated, however we suggest each mandrel be rechecked by applying grease.

Each mandrel should be filled with grease thru the Grease Fitting located between mower blade and underside of the mower housing (Fig. 11A). Wipe fitting clean before greasing. Use high performance, extreme pressure lubricating grease, (Amdex No. 1 EP or equivalent). Add grease until it oozes out around the cap above the blade and under the sheave. This will not damage the grease retainer. Wipe mandrel clean of excess grease. Under normal usage the mandrels should require lubrication after every 50 hours of operation and at the beginning of each new season. This grease may be obtained by ordering thru your nearest Sears repair parts department. Part No. 2557R.

Reattach spark plug wire(s) to spark plug(s).

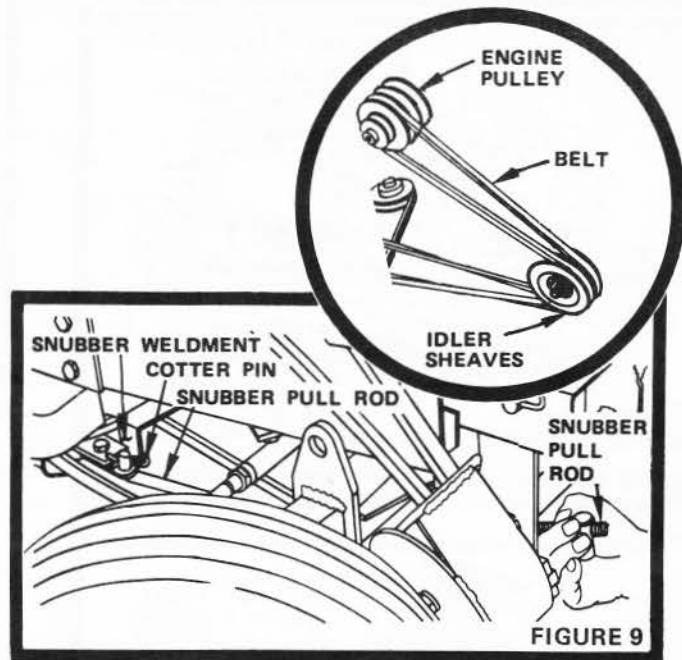

FIGURE 9

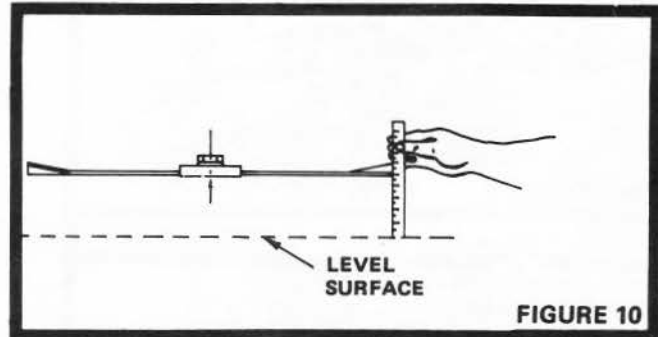

FIGURE 10

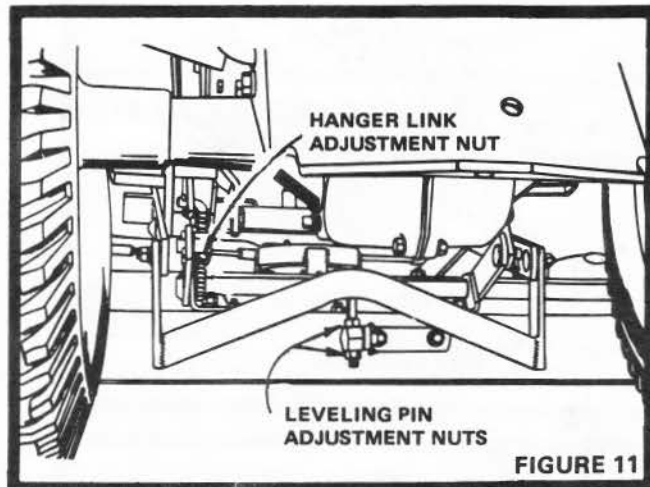

FIGURE 11

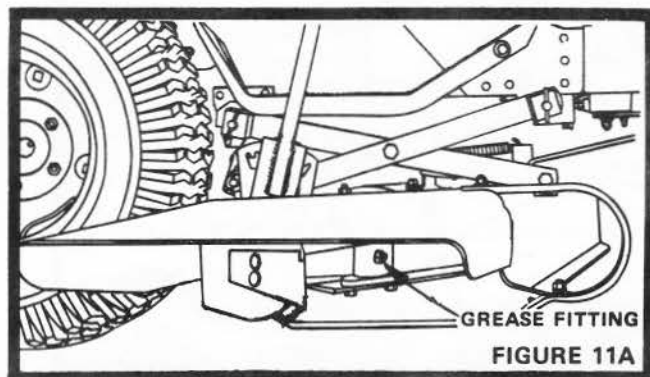

FIGURE 11A

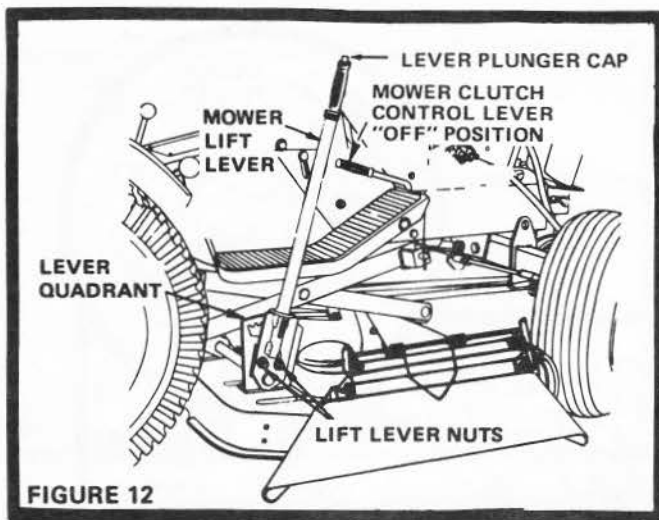

FIGURE 12

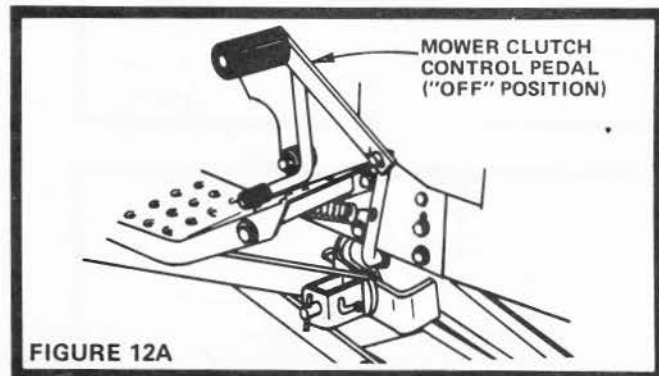

FIGURE 12A

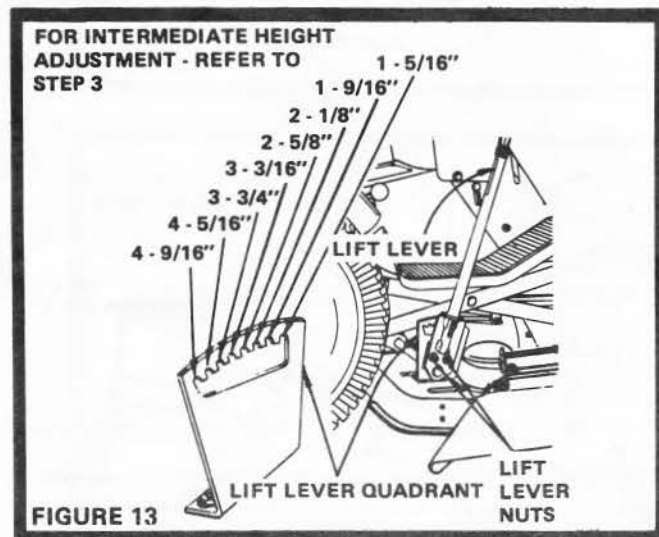

FIGURE 13

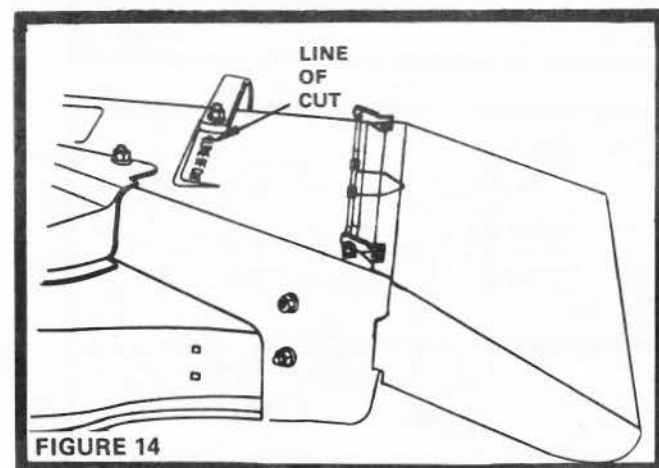

FIGURE 14

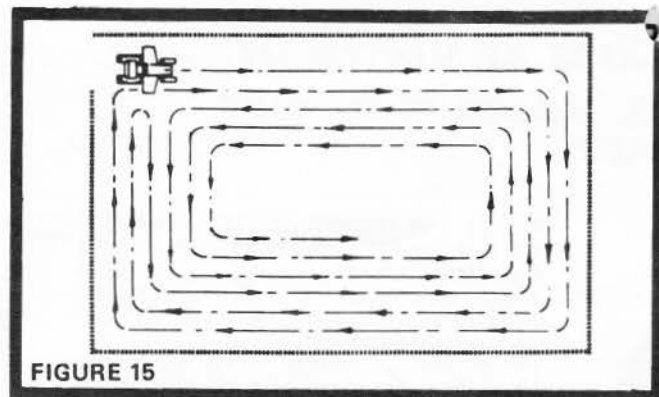

FIGURE 15

OPERATING INSTRUCTIONS



DO NOT OPERATE THE MOWER WITHOUT EITHER THE ENTIRE GRASS CATCHER, ON MOWERS SO EQUIPPED, OR THE DEFLECTOR SHIELD IN PLACE.



CAUTION

1. Keep all shields in place.
2. Before leaving operator's position:
 - a. Shift transmission to neutral
 - b. Set parking brake
 - c. Disengage attachment clutch
 - d. Shut off engine
 - e. Remove ignition key
3. Wait for all movement to stop before servicing machine.
4. Keep people and pets a safe distance away from machine.



READ THE "RULES FOR SAFE OPERATION" CAREFULLY BEFORE OPERATING YOUR MOWER.

THE MAIN DRIVE BELT (ENGINE TO CENTER MANDREL) MUST BE PROPERLY ADJUSTED BEFORE OPERATING. A DRIVE BELT NOT PROPERLY ADJUSTED CAN BE RUINED IN JUST A FEW MINUTES OF OPERATION. REFER TO STEP 1, PAGE 4. THE MOWER MUST BE LEVELED FROM SIDE TO SIDE, AND FROM FRONT TO REAR, BEFORE OPERATING. (REFER TO PAGE 5). THIS IS NECESSARY FOR LEVEL AND EFFICIENT MOWING.

NOTE: Place Gear Shift Lever in neutral and unlock Parking Brake. Depress tractor clutch pedal and disengage ("OFF" position) Mower Clutch Control (Fig. 12 or 12A).

1. START TRACTOR AND SET ENGINE SPEED TO ABOUT 1/3 TO 1/2 THROTTLE BEFORE ENGAGING MOWER. IN EITHER CASE, ENGAGE ("ON" POSITION) OR DISENGAGE ("OFF" POSITION) MOWER CLUTCH CONTROL SLOWLY. AFTER MOWER IS ENGAGED ("ON" POSITION) SET TO FULL THROTTLE.



NEVER ENGAGE ("ON" POSITION) MOWER EXCEPT WHEN SITTING ON TRACTOR SEAT.

2. START MOWING IN A LOW RANGE AND INCREASE GROUND SPEED BY CHANGING GEARS AS CONDITIONS WILL PERMIT. Average cutting height is approximately 2 - 1/2 to 2 - 3/4 inches. Height of cut can be adjusted by means of the Lift Lever (Fig. 13). Moving the lever forward lowers the mower. Moving it backwards raises the mower. The lever latch is actuated by depressing the lever plunger cap at the top of the lever handle (Fig. 12). Each notch changes the height of cut approximately 1/2 inch.
3. Should some intermediate height be desired, loosen the two Nuts at the bottom of the Lift Lever (Fig. 13). Rotate the Lever forward or backward relative to the shaft. Forward movement will raise the height of cut. Rearward movement will lower the height of cut. This adjustment will raise or lower the cutting range approximately 1/2 inch - the equivalent of one notch on the Lift Lever Quadrant. Retighten Lift Lever Nuts securely.

Drive so that clippings are discharged onto the area that has been cut. See Fig. 14 for line of cut on right hand side of mower. Have the cut area to the right of the machine. This will result in a more even distribution of clippings and more uniform cutting. When mowing large areas (Fig. 15), start by turning to the right so that the clippings will be discharged away from shrubs, fences, driveways, etc. After two or three rounds, mow in the opposite direction making left hand turns until finished. If grass is extremely tall, it should be mowed twice. The first time cut relatively high. The second time to the desired height. The left hand side of mower should be used for trimming.

MAINTENANCE INSTRUCTIONS

BLADE CARE

For best results mower blades must be kept sharp. The blades can be sharpened with a few strokes of a file or on a grinding wheel. Do not attempt to sharpen while on mower.



PLACE THE MOWER CLUTCH CONTROL IN THE "OFF" POSITION, LOCK THE PARKING BRAKE, SHIFT INTO NEUTRAL AND SHUT OFF THE ENGINE. MAKE ABSOLUTELY SURE THE BLADES AND ALL MOVING PARTS HAVE COMPLETELY STOPPED. REMOVE THE IGNITION KEY, DISCONNECT THE SPARK PLUG WIRE(S) FROM THE SPARK PLUG(S) AND KEEP WIRE(S) AWAY FROM THE PLUG(S) TO PREVENT INJURY FROM ACCIDENTAL STARTING.

When grinding, care should be taken to maintain blade balance and the blade should be checked for proper balance before re-installation on mower. Unbalanced or bent blade will cause excessive vibration when running, and eventual damage to mower or engine. Replace bent or damaged blades.

To insure satisfactory operation, it is recommended that before the start of each mowing season, the old blades be discarded and replaced with new blades. Mower blades can be purchased at all Sears retail stores and mail order outlets.

BLADE REPLACEMENT

It is not necessary to remove mower from tractor for blade replacement. Raising mower lift lever to highest position will permit access to blades.

1. Remove the two Hex Head Bolts and Lockwashers (Fig. 16).
2. Install new blade with SHARP EDGE DOWN and secure with two Lockwashers and two Hex Head Bolts. TIGHTEN SECURELY.



ALWAYS USE GRADE 5 HEAT TREATED BOLTS TO ATTACH BLADES. CHECK BOLTS IN BLADES OCCASIONALLY TO MAKE SURE BOLTS ARE TIGHT. TORQUE BOLTS 45 - 50 FT. LBS.

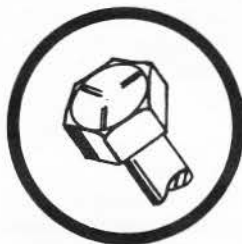

A GRADE 5 HEAT TREATED BOLT CAN BE IDENTIFIED BY THREE LINES INDICATED ON THE BOLT HEAD AS SHOWN AT LEFT.

CLEANING MOWER



DISCONNECT SPARK PLUG WIRE(S) TO PREVENT ACCIDENTAL STARTING BEFORE CLEANING.

Water pressure from a garden hose will remove fresh clippings from underside of mower. Clean mower after each mowing.

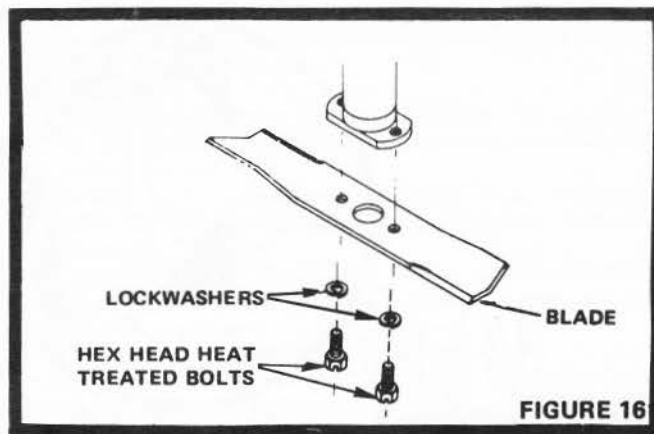

FIGURE 16

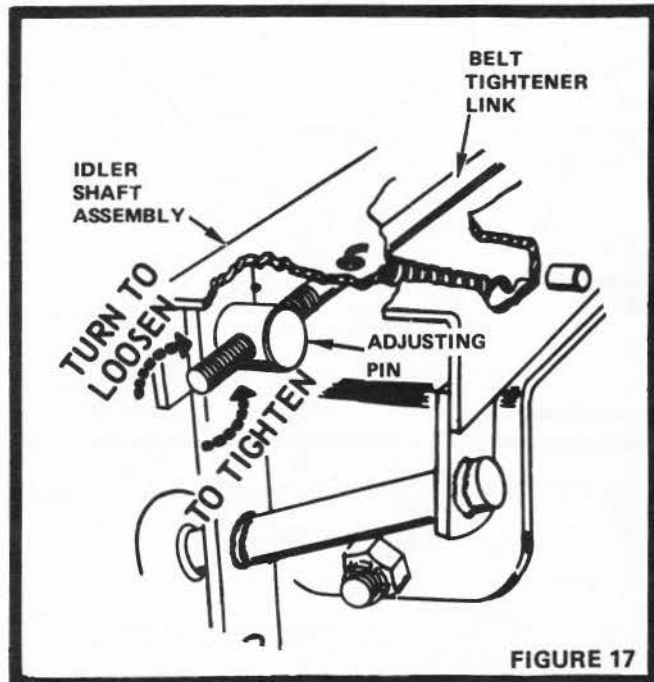

FIGURE 17

DAILY MAINTENANCE

Make sure all nuts on bolts are tight, cotter pins and retainer springs are secure. Keep blades sharp. Observe all safety precautions. Keep mower well lubricated.

BELT ADJUSTMENT

Remove Retainer Spring from Adjusting Pin and remove Adjusting Pin from Idler Shaft Assembly (Fig. 17).

(Refer to Fig. 18). Remove Retainer Spring from Adjusting Pin on Snubber Pull Rod in Idler Shaft Assembly. Remove Adjusting Pin from hole.

(Refer to Fig. 17). Turn Adjusting Pin on Belt Tightener Link counterclockwise to tighten belt, clockwise to loosen belt.

Engage ("ON" position) mower clutch control (pushed forward). Belt is properly adjusted when belt can be squeezed together with thumb and fore finger (without undue pressure) midway between engine and idler pulleys. After 2 hours use recheck belt for proper tension. Replace retainer spring in Adjusting Pin (Fig. 17).

Belt from center to outside mandrels is spring loaded and no adjustment is necessary.



AT THIS TIME YOU MUST ADJUST THE SNUBBER PULL ROD. FOLLOW THE INFORMATION UNDER "ADJUSTMENT OF SNUBBER" ON PAGE 8.

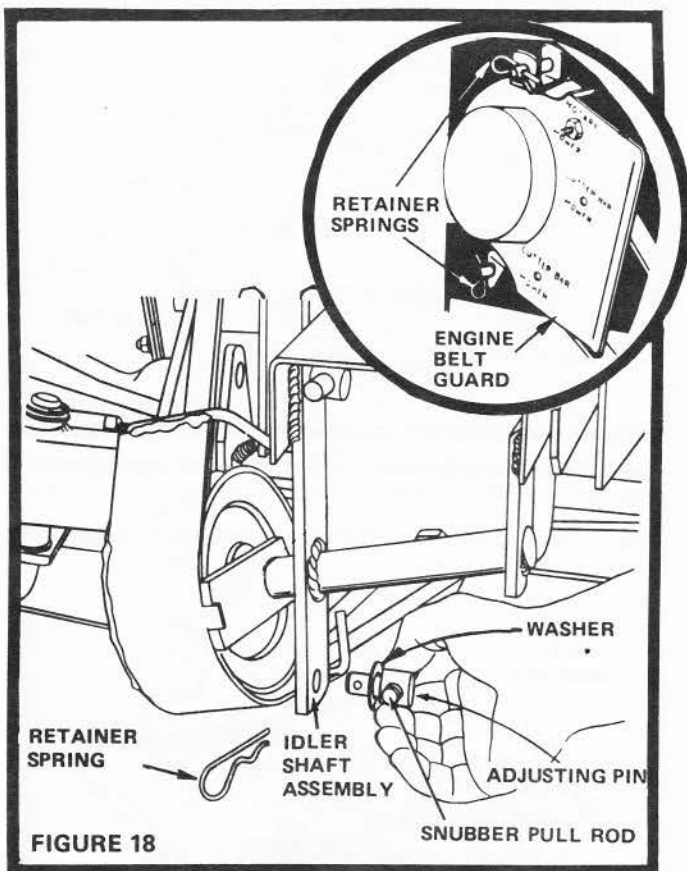

FIGURE 18

ADJUSTMENT OF SNUBBER (BRAKE FOR MANDRELS)

After belt has been properly adjusted, adjust Adjusting Pin on Snubber Pull Rod as stated below:

Place Mower Clutch Control in "OFF" position (Fig. 7A or 7B).

Remove Retainer Spring holding Adjusting Pin on Snubber Pull Rod in Idler Shaft Assembly. Remove Adjusting Pin from hole. With the Mower Clutch Control in the "OFF" position, turn Adjusting Pin on Snubber Pull Rod until Adjusting Pin will fit freely in hole of Idler Shaft Assembly. Remove Adjusting Pin from hole. Turn Adjusting Pin counterclockwise 6 complete turns and replace Washer on Pin against shoulder. Reinsert Pin with Washer in hole of Idler Shaft Assembly. NOTE: Mower Clutch Control can be pulled ahead to assemble. Secure with Retainer Spring.

Mower Blades should stop within seven (7) seconds after Clutch is disengaged.



MAKE SURE THAT BRAKE IS NOT AGAINST MANDREL PULLEY WHEN MOWER IS ENGAGED (LEVER OR PEDAL PUSHED FORWARD).

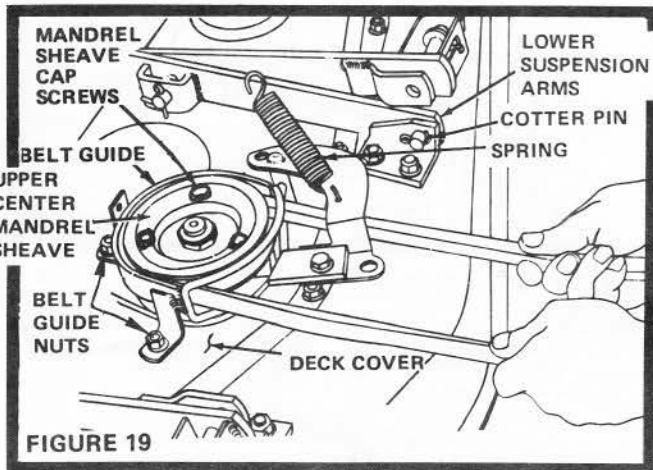

FIGURE 19

If Snubber Pull Rod is ever removed, be sure it is reassembled with slight bend in Rod downward and under the mower drive belt. Refer to Fig. 9, page 4.

BELT REPLACEMENT MOWER MAIN DRIVE BELT

1. Unhook Spring from rear belt guide bracket of Belt Guide (Fig. 19).
2. Remove Belt Guide at center mandrel by removing three (3) Nuts and Lockwashers.
3. Remove Nut and Lockwasher from Idler Shaft Assembly and remove Belt Guide (Fig. 19A). Also remove Engine Belt Guard and Belt (Fig. 18).
4. Install new Belt on Center Mandrel first, then on Idler Sheaves and on Engine Pulley. NOTE: See Fig. 19A for proper way of installing Belts on Idler Sheaves. Backside (outside) of Belt must be placed in flat (outside) Idler. Belt must be placed in largest groove of Engine Pulley. Replace Belt Guide securely.
5. Replace Engine Belt Guard (Fig. 18).
6. Replace Belt Guide and snubber at center mandrel and adjust so that there is 1/16 to 1/8 inch clearance between it and the Sheave. Replace Spring (Fig. 19). Adjust drive belt and snubber refer to page 4, steps 1 thru 8.

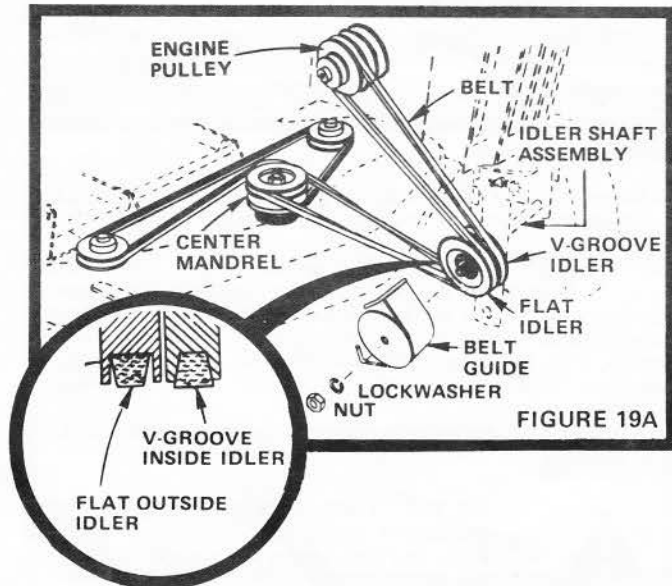

FIGURE 19A

(CENTER TO OUTER MANDRELS)

1. Remove Mower from Tractor page 10.
2. Unhook Spring from rear of Belt Guide. Remove Belt Guide at Center Mandrel by removing the 3 Belt Guide Nuts, Lockwashers and Flat Washers (Fig. 19).
3. Remove Belt from top groove of Upper Center Mandrel Sheave (Fig. 19).
4. Remove Cotter Pins at front of Lower Suspension Arms (Fig. 19).
5. Move Suspension Linkage outward and swing to rear--both R.H. and L.H. sides (Fig. 20).
6. 48" MOWER ONLY. Remove the 3 Cap Screws and Lockwashers and remove Upper Center Mandrel Sheave (Fig. 19).



LOCK CENTER BLADE TO KEEP FROM TURNING.

7. Remove Mower Deck Cover (Fig. 20). There are 9 Carriage Bolts, Flat Washers, Lockwashers and Hex Nuts (A), plus a Lockwasher and Hex Nut (B) holding Cover to Mower Housing.
8. Remove 1 rear Carriage Bolt, Flat Washer, Lockwasher and Nut in Belt Guide at L.H. Mandrel Sheave. Loosen the other bolt and swing Belt Guide to one side as shown in Fig. 20A.
9. Remove old Belt.
10. Remove any dirt and grass which may have accumulated around Sheaves and Idler Arm.
11. Check Deck Idler Arm Assembly and Flat Idler to see that they rotate freely (Fig. 20A).
12. Be sure Spring is hooked in Deck Idler Arm Assembly and Mower Housing (Fig. 20A).
13. Install new Belt in groove of L.H. Mandrel Sheave, lower groove of Center Mandrel Sheave and around Flat Idler as shown in Fig. 20A.
14. From a position at discharge end of Mower, pull Belt until it goes into groove of R.H. Mandrel Sheave (Fig. 20A).
15. Rotate Center Sheave by hand to make sure Belt is running into grooves properly.

BLADES WILL ROTATE WITH CENTER SHEAVE.



16. Reassemble Belt Guide at L.H. Mandrel (Fig. 20A). Adjust so that there is 1/16 to 3/32 inch clearance between Guide and Belt all around.
17. Reassemble Mower Deck Cover (Fig. 20). Make sure bolt shoulders are seated in Mower Housing bolt holes. Tighten Nuts securely.
18. 48" MOWER ONLY. Reassemble Upper Center Mandrel Sheave with the 3 Cap Screws and Lockwashers removed in Step 6. Tighten securely.
19. With Main Drive Belt in position, replace Belt Guide and Snubbers at Center Mandrel. Adjust so that there is 1/16 to 1/8 inch clearance between Belt Guide and Sheave (Fig. 19).
20. Replace Suspension Arms in their original position and secure with Cotter Pins (Fig. 19).
21. Adjust Drive Belt, refer to "Belt Adjustment", page 7. Adjust Snubber, refer to "Adjustment of Snubber", page 8.

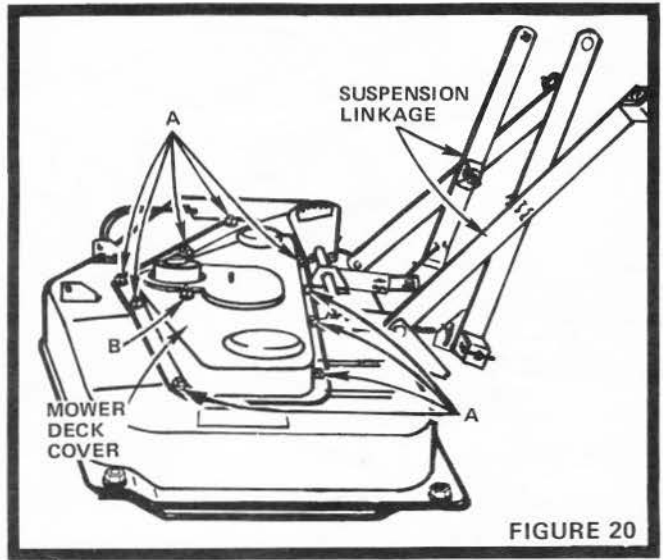

FIGURE 20

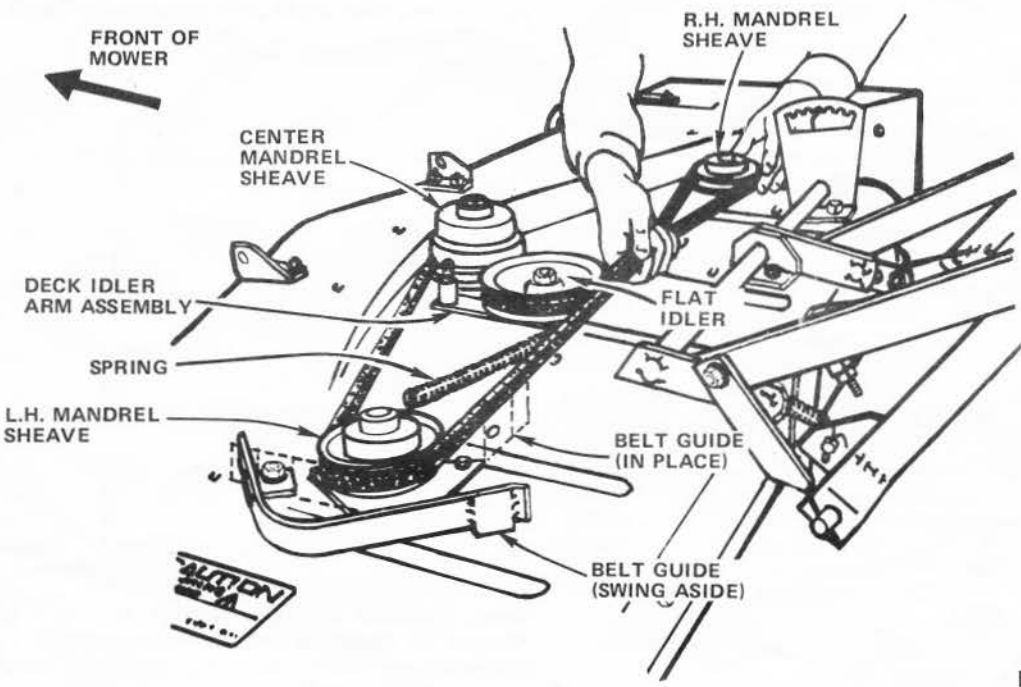
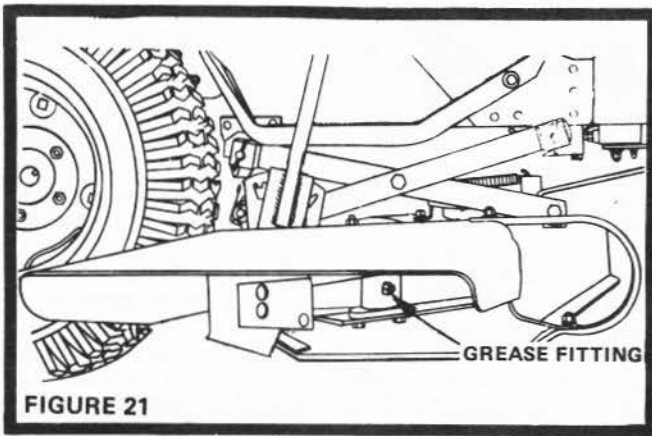

FIGURE 20A



REMOVING MOWER FROM TRACTOR

1. Disengage Mower Clutch Control ("OFF" position).
2. Remove Engine Belt Guard (Fig. 18).
3. Remove belt from Engine Pulley.
4. (Refer to Fig. 7). Remove Retainer Spring holding Adjusting Pin to Idler Shaft Assembly. Remove Adjusting Pin from Idler Shaft Assembly.
5. (Refer to Fig. 18). Remove Retainer Spring from Adjusting Pin. Remove Adjusting Pin from Idler Shaft Assembly. Unhook Spring from Idler Frame and Front Axle Bracket. (Fig. 5). Remove Idler Shaft Assembly from front of tractor and place on ground between front wheels.
6. Lower mower by means of the Lift Lever (Fig. 12), to its extreme low position.
7. Pull all four Attaching Plungers (Fig. 2) outward to detach mower from tractor.
8. Turn front wheels to left and slide mower out from under R.H. side of tractor.

STORAGE

Remove mower from tractor for winter storage. When mower is to be stored for a period of time, clean it thoroughly, remove all dirt, grease, leaves, etc. Give blades and underside of housing a good coat of grease or rust preventative. Store in a clean dry area.

Each mandrel should be filled with grease thru the Grease Fitting located between mower blade and underside of the mower housing (Fig. 21). Wipe fitting clean before greasing. Use high performance extreme pressure lubricating grease, (Amdex No. 1 EP or equivalent). Add grease until it oozes out around the cap above the blade and under the sheave. This will not damage the grease retainer. Wipe mandrel clean of excess grease. This grease may be obtained by ordering thru your nearest Sears repair parts department. Part No. 2557R.

Sears, Roebuck and Co. reserves the right to make any changes in design or improvements without imposing any obligation to install the same upon its items heretofore manufactured.

REPAIR PARTS

42" ROTARY MOWER--MODEL NUMBER 917.253582
 48" ROTARY MOWER--MODEL NUMBER 917.253592

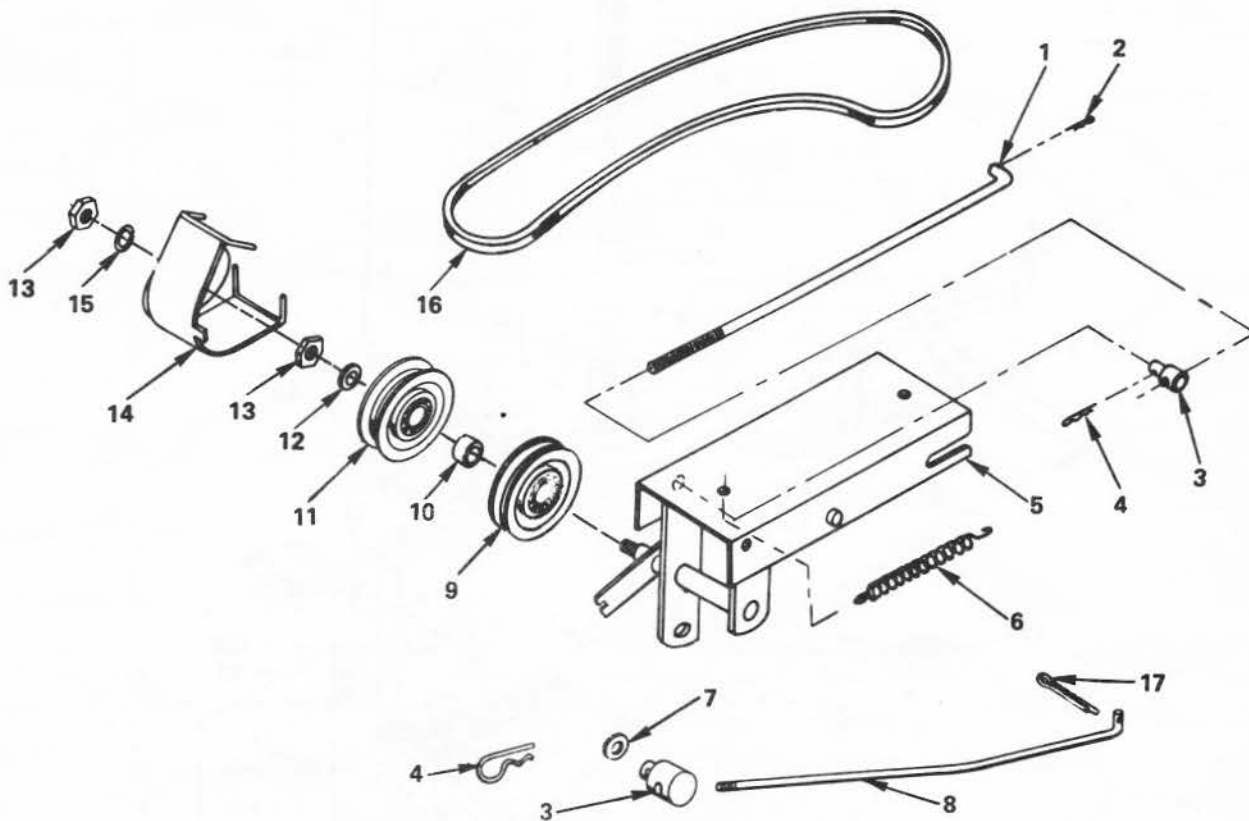

KEY NO.	42"	48"	PART NO.	DESCRIPTION
1	X	X	3705R	Belt Tightener Link
2	X	X	4939M	Retainer Spring
3	X	X	3707R	Adjusting Pin
4	X	X	4940M	Retainer Spring
5	X	X	634A619	Idler Shaft Assembly
6	X	X	3218J	Spring
7	X	X	1569P	Washer 9/16 x 15/16 x 11 Ga.
8	X	X	3766R	Snubber Pull Rod
9	X	X	634A565	Inside Idler
10	X	X	5386H	Bushing
11	X	X	634A566	Outside Idler
12	X	X	1519P	Washer 15/32 x 1 x 12 Ga.
13	X	X	STD541143	*Hex Nut 7/16 - 20 UNF
14	X	X	634A618	Belt Guide Weldment - Front
15	X	X	STD551143	*Lockwasher 7/16 - Heavy
16	X	X	6941R	V-Belt (Engine to Center Mandrel)
17	X	X	2510P	Cotter Pin 5/32 x 1

*STANDARD HARDWARE--PURCHASE LOCALLY

REPAIR PARTS

42" ROTARY MOWER--MODEL NUMBER 917.253582
 48" ROTARY MOWER--MODEL NUMBER 917.253592

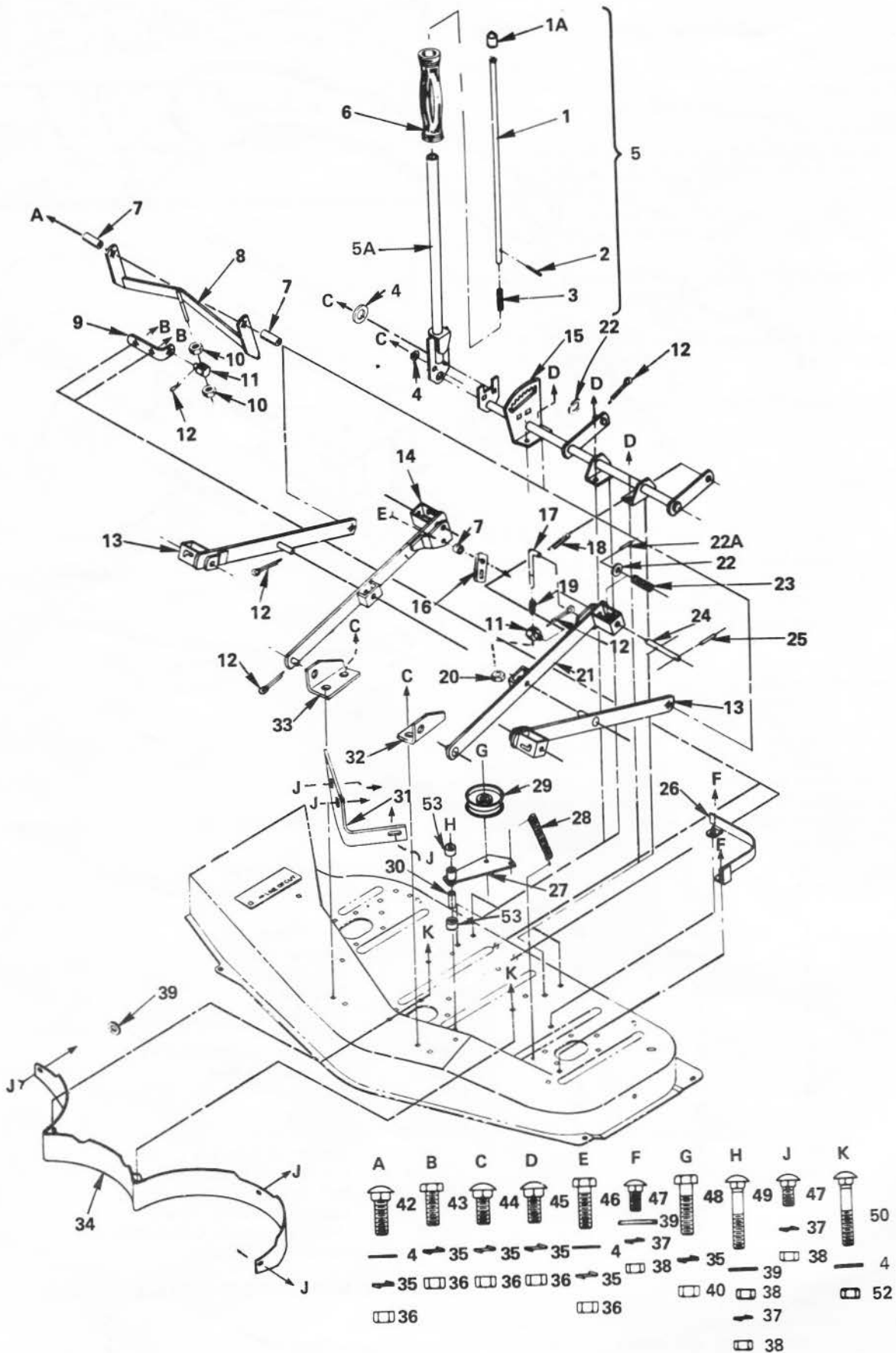

another free manual from www.searstractormanuals.com

REPAIR PARTS

42" ROTARY MOWER--MODEL NUMBER 917.253582
 48" ROTARY MOWER--MODEL NUMBER 917.253592

KEY NO.	42"	48"	PART NO.	DESCRIPTION
1	X	X	9083R	Lever Plunger
1A	X	X	9479R	Lever Plunger Cap
2	X	X	8540R	Drive Lock Pin 3/16 x 1 - 1/2
3	X	X	2876H	Spring
4	X	X	1556P	Washer 13/32 x 7/8 x 14 Ga.
5	X	X	673A61	Lift Lever w/Plunger (Inc. Key No's. 1, 1A, 2 & 3)
5A	X	X	673A60	Lift Lever Weldment
6	X	X	2895H	Handle Grip
7	X	X	280M1	Bushing
8	X	X	634A358	Pitch Adjustment Weldment
9	X	X	9426H	Pitch Adjustment Bracket
10	X	X	STD541137	*Hex Nut 3/8 - 24 UNF
11	X	X	9420H	Leveling Pin
12	X	X	2511P	Cotter Pin 3/16 x 1
13	X		634A345	Suspension Arm Weldment - Outer
13		X	634A348	Suspension Arm Weldment - Outer
14	X		634A344	Suspension Arm Weldment - Inner - R.H.
14		X	634A347	Suspension Arm Weldment - Inner - R.H.
15	X	X	634A879	Lift Shaft Weldment
16	X	X	929R	Lift Link
17	X	X	9412H	Hanger Link
18	X	X	2505P	Cotter Pin 1/8 x 3/4
19	X	X	9535H	Spring
20	X	X	9505H	Elastic Stop Nut 3/8 - 24 UNF
21	X		634A343	Suspension Arm Weldment - Inner - L.H.
21		X	634A346	Suspension Arm Weldment - Inner - L.H.
22	X	X	STD551050	*Washer 17/32 x 1 - 1/16 x 13 Ga.
22A	X	X	9465M	Roll Pin 3/16 x 1 - 1/2
23	X	X	3720R	Spring
24	X	X	9416H	Plunger
25	X	X	9504H	Roll Pin 3/16 x 2
26	X	X	634A334	Belt Guide Assembly
27	X		634A854	Deck Idler Arm Assembly
27		X	634A477	Deck Idler Arm Assembly
28	X	X	3218J	Spring
29	X	X	2083R	Flat Idler
30	X	X	677A316	Idler Bushings, Washer and Seals (Inc. Dirt Seal, Key No. 53)
31	X		2289R	Discharge Cutoff Plate
31		X	2290R	Discharge Cutoff Plate
32	X	X	3544R	Suspension Bracket - Front - L.H.
33	X	X	3543R	Suspension Bracket - Front - R.H.
34	X		9422R	Blade Shield
34		X	9500R	Blade Shield
35	X	X	STD551137	*Lockwasher 3/8
36	X	X	STD541037	*Hex Nut 3/8 - 16 UNC
37	X	X	STD551131	*Lockwasher 5/16 - Heavy
38	X	X	STD541031	*Hex Nut 5/16 - 18 UNC
39	X	X	STD551031	*Washer 11/32 x 11/16 x 16 Ga.
40	X	X	STD541237	*Hex Jam Nut 3/8 - 16 UNC
42	X	X	STD533712	*Square Neck Carriage Bolt 3/8 - 16 x 1 - 1/4
43	X	X	STD523710	*Hex Bolt 3/8 - 16 x 1
44	X	X	STD533710	*Square Neck Carriage Bolt 3/8 - 16 x 1
45	X	X	61P	Sq. Neck Carriage Bolt - Sht. Shoulder 3/8 - 16 x 1 Gr. 5
46	X	X	STD523712	*Hex Bolt 3/8 - 16 x 1 - 1/4
47	X	X	67P	Square Neck Carriage Bolt 5/16 - 18 x 3/4 Gr. 5
48	X	X	STD523715	*Hex Bolt 3/8 - 16 x 1 - 1/2
49	X	X	7P	Square Neck Carriage Bolt 5/16 - 18 x 2 - 1/2
50	X	X	STD533730	*Square Neck Carriage Bolt 3/8 - 16 x 3
52	X	X	5394H	Locknut 3/8 - 16 UNC
53	X	X		Dirt Seal (Not sold separately, Order No. 30)
---	X	X	102343X	Warranty Tag
---	X	X	3193J	Owners Manual

*STANDARD HARDWARE--PURCHASE LOCALLY

REPAIR PARTS

42" ROTARY MOWER--MODEL NUMBER 917.253582

48" ROTARY MOWER--MODEL NUMBER 917.253592

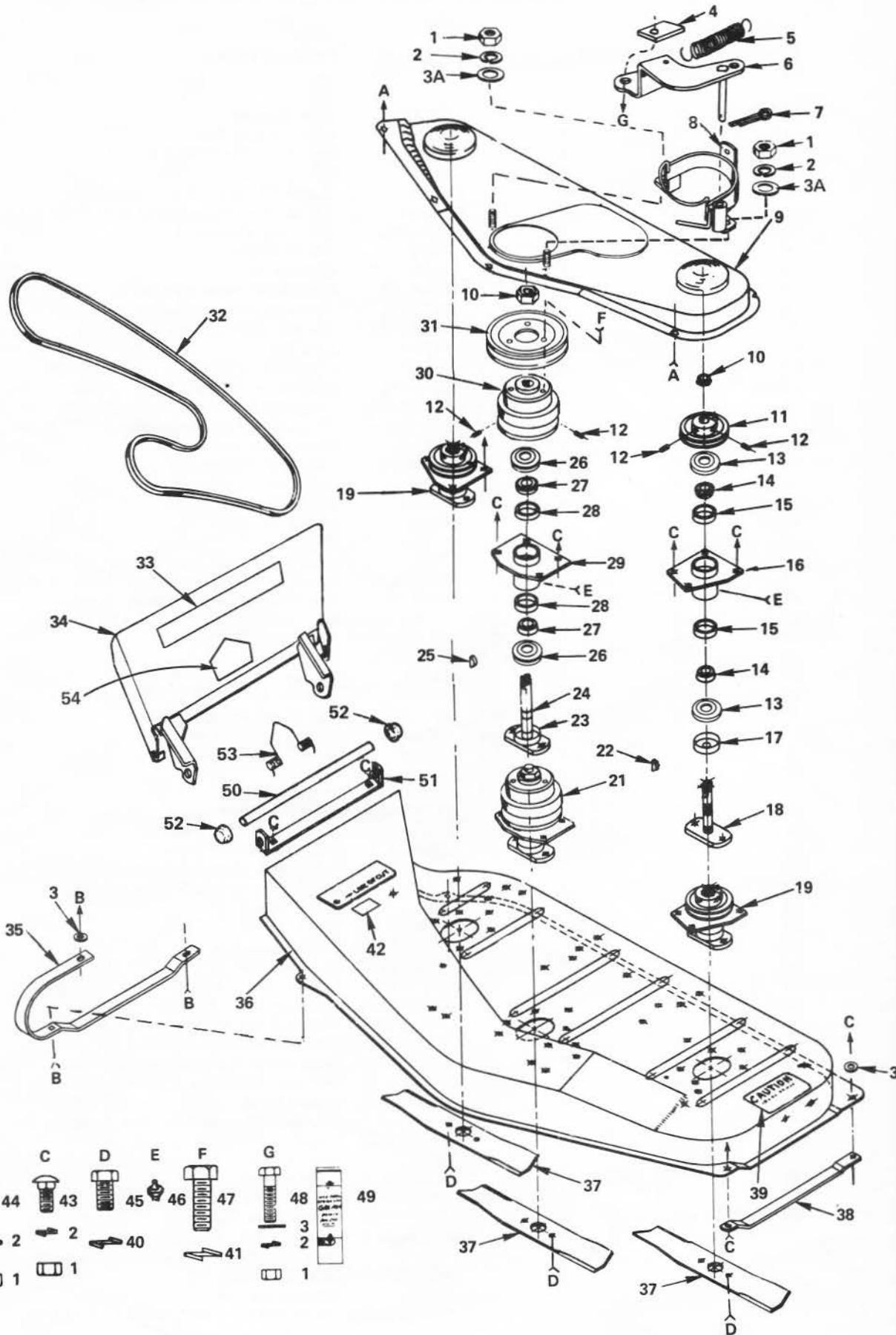

REPAIR PARTS

42" ROTARY MOWER--MODEL NUMBER 917.253582

48" ROTARY MOWER--MODEL NUMBER 917.253592

KEY NO.	42"	48"	PART NO.	DESCRIPTION
1	X	X	STD541031	*Hex Nut 5/16 - 18 UNC
2	X	X	STD551131	*Lockwasher 5/16 - Heavy
3	X	X	STD551031	*Washer 11/32 x 11/16 x 16 Ga.
3A	X	X	1623P	Washer 11/32 x 7/8 x 16 Ga.
4	X	X	2629R	Brake Shoe
5	X	X	3770R	Spring
6	X		634A590	Snubber Weldment
6		X	634A592	Snubber Weldment
7	X	X	STD560907	*Cotter Pin 3/32 x 3/4
8	X		677A290	Belt Guide Weldment - Center
8		X	677A289	Belt Guide Weldment - Center
9	X		634A856	Deck Drive Cover and Weld Bolts
9		X	634A484	Deck Drive Cover and Weld Bolts
10	X	X	4831H	Elastic Stop Nut 3/4 - 16 UNF
11	X	X	634A417	Mandrel Sheave - Outer w/Set Screws (Inc. 2 Each Key No. 12)
12	X	X	4539P	Hex Forged Socket Headless Set Screw C.P. 3/8 - 16 x 5/8
13	X	X	881R	Metallic Seal
14	X	X	1554H	Bearing Cone
15	X	X	1553H	Bearing Cup
16	X	X	634A431	Mandrel Tube and Cups - Outer (Inc. Key No. 15)
17	X	X	9458H	Mandrel Cap
18	X	X	634A315	Shaft and Flange - Outer
19	X	X	634A423	Mandrel Assembly with Sheave - Outer (Inc. Key No's. 10 thru 18, 22 and 46)
21	X		677A288	Mandrel Assembly with Sheave - Center (Inc. Key No's. 10, 25, 26, 27, 29, 30 and 46)
21		X	677A154	Mandrel Assembly with Sheave - Center (Inc. Key No's. 10, 25, 26, 27, 29, 30 and 46)
22	X	X	8330H	Woodruff Key 1/4 x 1 H.T.
23	X	X	1036R	Mandrel Cap - Center
24	X	X	634A426	Shaft and Flange - Center
25	X	X	880R	Woodruff Key 1/4 x 2 - 1/8 H.T.
26	X	X	882R	Metallic Seal
27	X	X	9494H	Bearing Cone
28	X	X	888R	Bearing Cup
29	X	X	634A427	Mandrel Tube and Cup - Center (Inc. Key No. 28)
30	X		677A291	Mandrel Sheave - Center with Set Screws (Inc. 3 Each Key No. 12)
30		X	677A160	Mandrel Sheave Center With Set Screws (Inc. 3 Each Key No. 12)
31		X	3215J	Mandrel Sheave Upper - Center
32	X		6942R	V-Belt (Center to Outer Mandrels)
32		X	6943R	V-Belt (Center to Outer Mandrels)
33	X	X	643J	Deflector - Caution Decal
34	X		677A153	Deflector Shield Weldment
34		X	677A152	Deflector Shield Weldment
35	X		8063R	Runner - R. H.
35		X	8064R	Runner - R.H.
36	X		9482R	Mower Housing
36		X	9536R	Mower Housing
37	X		9480R	Blade
37		X	9497R	Blade
38	X		677A510	Runner Assembly - L.H.
38		X	2071R	Runner - L.H.
39	X	X	9133R	Instruction - Caution Decal
40	X	X	STD551143	*Lockwasher 7/16
41		X	STD551137	*Lockwasher 3/8 - Heavy
42	X	X	9591R	Lift Decal
43	X	X	67P	Carriage Bolt 5/16 - 18 x 3/4 Gr. 5
44	X	X	STD523110	*Hex Bolt 5/16 - 18 x 1 Grade 5
45	X	X	3204P	Hex Bolt 7/16 - 14 x 3/4 Grade 5
46	X	X	6855M	Grease Fitting
47		X	STD523710	*Hex Bolt 3/8 - 16 x 1
48	X	X	STD523110	*Hex Bolt 5/16 - 18 x 1
49	X	X	2557R	Amdex No. 1 E.P. Grease (Not Furnished with Mower)
50	X	X	9082R	Deflector Shield Rod
51	X	X	9098R	Deflector Shield Bracket
52	X	X	5846R	Push Nut
53	X	X	5848R	Torsion Spring
54	X	X	3495J	Label, Warning

OPTIONAL EQUIPMENT

GAUGE WHEEL KIT CATALOG NO. 25383

Your mower is of the full floating type and will closely follow the contours of the ground when using the gauge wheels for height of cut position. They prevent soil gouging on sloping terrain.

ASSEMBLY

PLACE THE MOWER CLUTCH CONTROL LEVER IN THE "OFF" POSITION, LOCK THE PARKING BRAKE, SHIFT INTO NEUTRAL AND SHUT OFF THE ENGINE. MAKE ABSOLUTELY SURE THE BLADES AND ALL MOVING PARTS HAVE COMPLETELY STOPPED. REMOVE THE IGNITION KEY, DISCONNECT THE SPARK PLUG WIRE(S) FROM THE SPARK PLUG(S) AND KEEP WIRE(S) AWAY FROM THE PLUG(S) TO PREVENT INJURY FROM ACCIDENTAL STARTING.

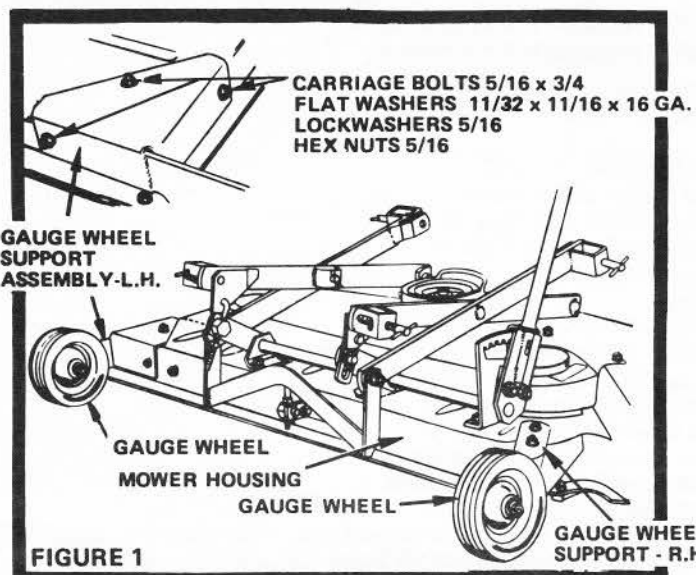

FIGURE 1

1. Move lift lever so that mower is in its highest position.

2. Assemble Gauge Wheel Support Assembly - L.H. to Mower Housing (Fig. 1) with three 5/16 x 3/4 Carriage Bolts, 11/32 x 11/16 x 16 Ga. Flat Washers, 5/16 Lockwashers and 5/16 Hex Nuts. Heads of Bolts to inside; Flat Washers between Gauge Wheel Support and Lockwashers. Tighten nuts securely.

3. Assemble Gauge Wheel Support - R.H. to Mower Housing (Fig. 2).

a. Loosely assemble Gauge Wheel Support - R.H. to Mower Housing using a 5/16 x 1 Carriage Bolt, 11/32 x 11/16 x 16 Ga. Flat Washer, 5/16 Lockwasher and 5/16 Hex Nut. Head of bolt to inside; Flat Washer between Lockwasher and Gauge Wheel Support.

b. Remove and discard the carriage bolt, lockwasher and nut at rear of Runner - R.H. Position the end of the Gauge Wheel Bracket Support - R.H. with the larger hole over Runner. Loosely secure with a 5/16 x 1 - 1/4 Hex Bolt (head to outside as shown), 5/16 Lockwasher and 5/16 Hex Nut.

c. Loosely assemble Gauge Wheel Bracket Support - R.H. to Gauge Wheel Support - R.H. with a 5/16 x 1 Carriage Bolt, 5/16 Lockwasher and 5/16 Hex Nut. Head of bolt to underside.

d. Tighten all three Nuts securely.

4. Assemble Gauge Wheels to R.H. side of each Gauge Wheel Support (Fig. 3). Use the top hole in each Support. NOTE: A Bushing must be inside each wheel hub and a 13/32 x 7/8 x 14 Ga. Washer must be on each side of wheel. Thicker portion of wheel hubs must be toward Gauge Wheel Supports. Tighten nuts securely.

5. Be sure to replace spark plug wire(s) to spark plug(s).

ADJUSTMENT

After following the "Operating Instructions" on page 6 adjust gauge wheels.

If gauge wheels are suspended, no tearing of the turf will occur on sharp turns by gauge wheels sliding sideways. There are four holes in the R.H. and L.H. gauge wheel supports. With lift lever set to give desired height of cut and with tractor and mower on level ground, adjust gauge wheels to one of the holes in gauge wheel supports so that they clear the ground by approximately 3/4 inch.

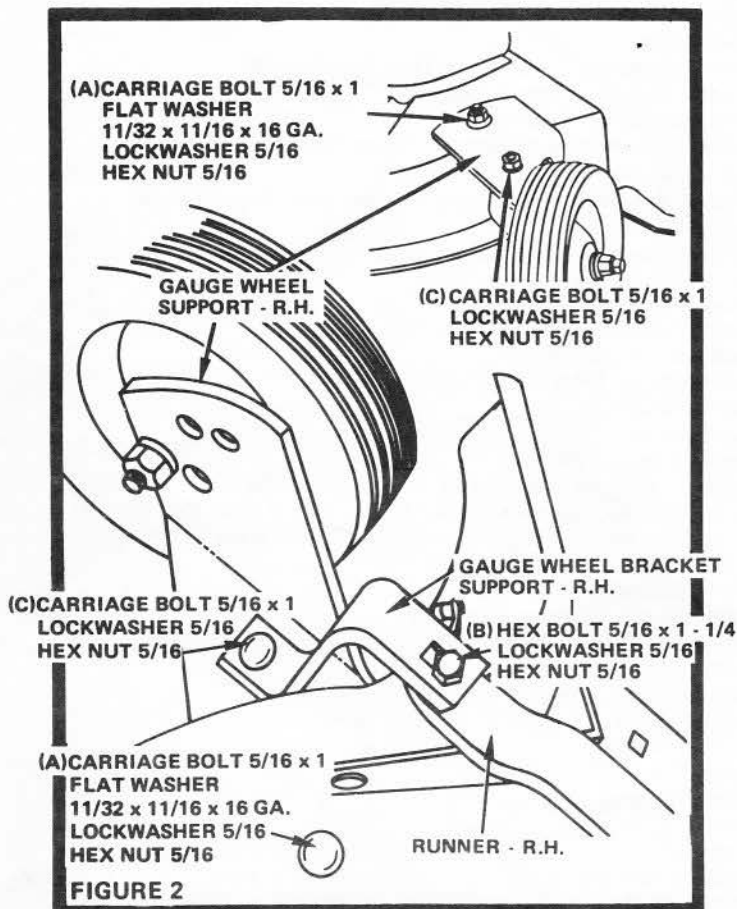

FIGURE 2

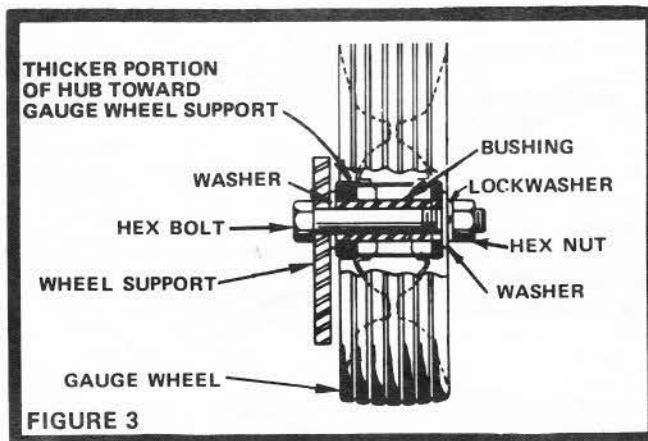
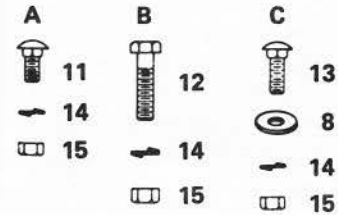
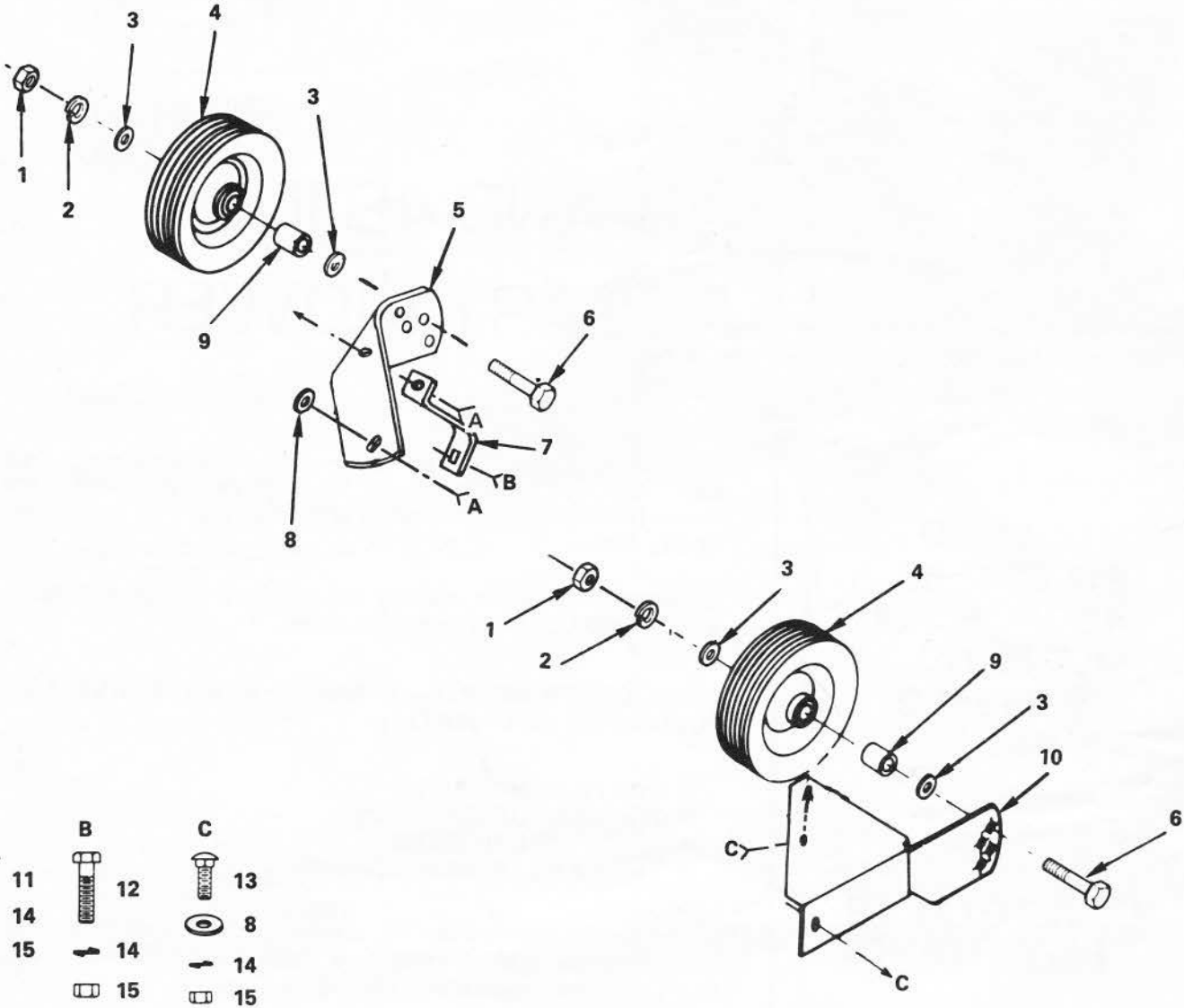

FIGURE 3

REPAIR PARTS

OPTIONAL EQUIPMENT ROTARY MOWER GAUGE WHEEL KIT CATALOG NO. 25383



KEY NO.	PART NO.	DESCRIPTION
1	STD541137	*Hex Nut 3/8 - 24 UNF
2	STD551137	*Lockwasher 3/8
3	STD551037	*Washer 13/32 x 7/8 x 14 Ga.
4	9536H	Gauge Wheel
5	2073R	Gauge Wheel Support - R.H.
6	3199P	Hex Bolt 3/8 - 24 x 2 - 3/4 Grade 5
7	8133R	Gauge Wheel Bracket Support - R.H.

KEY NO.	PART NO.	DESCRIPTION
8	STD551031	*Washer 11/32 x 11/16 x 16 Ga.
9	7375H	Bushing
10	634A480	Gauge Wheel Support Assembly - L.H.
11	STD533110	*Carriage Bolt 5/16 - 18 x 1
12	STD523112	*Hex Bolt 5/16 - 18 x 1 - 1/4 Grade 5
13	STD523107	*Carriage Bolt 5/16 - 18 x 3/4
14	STD551131	*Lockwasher 5/16
15	STD541031	*Hex Nut 5/16 - 18 UNC

*STANDARD HARDWARE--PURCHASE LOCALLY

Catalog No. 25383 includes all of the above items.

Sears

**OWNERS
MANUAL**

**MODEL NO.
917.253582
42 INCH AND
MODEL NO.
917.253592
48 INCH**

**HOW TO ORDER
REPAIR PARTS**

42 AND 48 INCH ROTARY MOWER

The Model Number will be found on a plate attached to the Rear R.H. side of the Mower Housing. Always mention the Model Number when requesting service or repair parts for your Rotary Mower.

All parts listed herein may be ordered from any SEARS ROEBUCK AND CO. retail or catalog store.

WHEN ORDERING REPAIR PARTS, ALWAYS GIVE THE FOLLOWING INFORMATION:

- THE PART NUMBER
- THE PART DESCRIPTION
- THE MODEL NUMBER
- THE NAME OF MERCHANDISE

If the parts you need are not stocked locally, your order will be electronically transmitted to a Sears Repair Parts Distribution Center for "expedited handling".