

1-800-438-3458

Sears

**MODEL NOS.
917.257111
AND
917.257112**

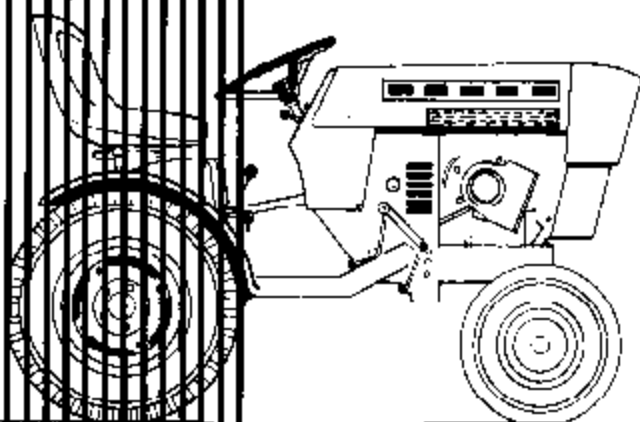

OWNER'S MANUAL

**GT 18 TWIN
GARDEN TRACTOR**

**Assembly Operation
Maintenance Repair Parts**

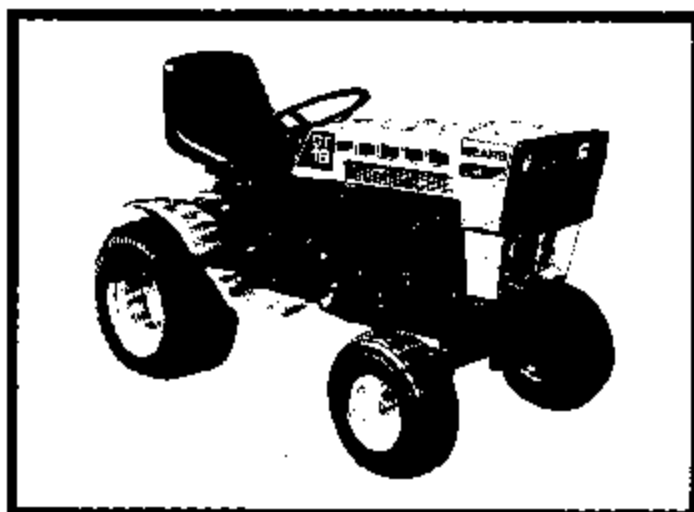

another free manual from www.searstractorsmanuals.com

TABLE OF CONTENTS

| | | | |
|------------------------------------|---|-----------------------------------|----|
| WARRANTY | 1 | MAINTENANCE INSTRUCTIONS. | 6 |
| RULES FOR SAFE OPERATION | 1 | TROUBLE SHOOTING | 11 |
| ASSEMBLY INSTRUCTIONS | 2 | REPAIR PARTS | 12 |
| OPERATION INSTRUCTIONS | 4 | | |

FULL ONE YEAR WARRANTY ON ELECTRIC START GARDEN TRACTOR

For one year from the date of purchase, when this Garden Tractor is used for personal household purposes, Sears will repair any defect in material or workmanship in this Garden Tractor, except the battery, at no charge.

If this Garden Tractor is used for commercial or rental purposes, this warranty applies for only 30 days from the date of purchase.

FULL 90-DAY WARRANTY ON BATTERY

For 90 days from the date of purchase, if any battery included with the Garden Tractor proves defective in material or workmanship and will not hold a charge, Sears will replace the battery, at no charge.

LIMITED WARRANTY ON BATTERY

From the 91st day until one year from the date of purchase, if any battery included with the Garden Tractor proves defective in material or workmanship and will not hold a charge, Sears will replace the battery, charging 1/12th of the price of the new battery for each full month from the date of purchase.

Warranty service is available at your home, at no charge, by simply contacting the nearest Sears store or Service Center throughout the United States.

This warranty gives you specific legal rights, and you may also have other rights which vary from state to state.

Sears, Roebuck and Co.
Sears Tower
BSC 41-3
Chicago, IL 60684

WARNING

This unit is equipped with an internal combustion engine and should not be used on or near any unimproved forest-covered, brush-covered or grass-covered land unless the engine's exhaust system is equipped with a spark arrester meeting applicable local or state laws (if any). If a spark arrester is used, it should be maintained in effective working order by the operator.

In the State of California the above is required by law (Section 4442 of the California Public Resources Code). Other states may have similar laws. Federal laws apply on federal lands. See your Sears Authorized Service Center for spark arrester muffler part number 673A224.

RULES FOR SAFE OPERATION

1. Know the controls and how to stop quickly. READ THE OWNER'S MANUAL.
2. Do not allow children to operate the vehicle. Do not allow adults to operate it without proper instruction.
3. Do not carry passengers. Keep children and pets a safe distance away.
4. Always wear substantial footwear. Do not wear loose fitting clothing that could get caught in moving parts.
5. Keep your eyes and mind on your tractor, mower and the area being cut. Don't let other interests distract you.
6. Do not attempt to operate your Tractor or mower when not in operator's seat.
7. Always get on or off your tractor from the operator's left hand side.
8. Clear the work area of objects which might be picked up and thrown.
9. Disengage all attachment clutches and shift into neutral before attempting to start the engine.
10. Disengage power to attachments and stop the engine before leaving the operator's position.
11. Disengage power to mower, stop the engine and disconnect spark plug wire(s) from spark plug(s) before cleaning, making an adjustment or repairs.
12. Disengage power to attachments when transporting or not in use.
13. Take all possible precautions when leaving the vehicle unattended, such as disengaging the power-take-off, lowering the attachments, shifting into neutral, setting the parking brake, stopping the engine, and removing the key.
14. Do not stop or start suddenly when going uphill or downhill. Mow up and down the face of slopes (not greater than 15°); never across the face.
15. Reduce speed on slopes and make turns gradually to prevent tipping or loss of control. Exercise extreme caution when changing direction on slopes.
16. Do not shift gears while going up or down slopes. Choose a gear low enough to negotiate the slope without stopping and shifting gears. To reduce speed, move throttle lever to slow.
17. Never mow in wet or slippery grass, when traction is unsure or at a speed which could cause a skid.
18. Stay alert for holes in the terrain and other hidden hazards.
19. Do not drive too close to creeks, ditches and public highways.
20. Exercise special care when mowing around fixed objects in order to prevent the blades from striking them. Never deliberately run tractor or mower into or over any foreign object.
21. Never shift gears until tractor comes to a stop.
22. Never place hands or feet under the mower, in the deflector (discharge chute) or near any moving parts while tractor or mower are running. Always keep clear of discharge chute.
23. Use care when pulling loads or using heavy equipment.
 - a. Use only approved drawbar hitch points.
 - b. Limit loads to those you can safely control.
 - c. Do not turn sharply. Use care when backing.
 - d. Use counterweights or wheel weights when suggested in this owner's manual.
24. Watch out for traffic when crossing or near roadways.
25. When using any attachments, never direct discharge of material toward bystanders nor allow anyone near the vehicle while in operation.
26. Handle gasoline with care - it is highly flammable.
 - a. Use approved gasoline containers.
 - b. Never remove the cap of the fuel tank or add gasoline to a running or hot engine, or fill the fuel tank indoors. Wipe up spilled gasoline.
 - c. Open doors if the engine is run in the garage - exhaust fumes are dangerous. Do not run the engine indoors.
27. Keep the vehicle and attachments in good operating condition, and keep safety devices in place.
28. Keep all nuts, bolts and screws tight to be sure the equipment is in safe working condition.
29. Never store the equipment with gasoline in the tank inside a building where fumes may reach an open flame or spark. Allow the engine to cool before storing in any enclosure.
30. To reduce fire hazard, keep the engine free of grass, leaves or excessive grease.
31. The vehicle and attachments should be stopped and inspected for damage after striking a foreign object, and the damage should be repaired before restarting and operating the equipment.
32. Do not change the engine governor settings or overspeed the engine.
33. When using the vehicle with mower, proceed as follows:
 - a. Mow only in daylight or in good artificial light.
 - b. Never make a cutting height adjustment while the engine is running if the operator must dismount to do so.
 - c. Shut the engine off when removing the grass catcher or unclogging chute.
 - d. Check the blade mounting bolts for proper tightness at frequent intervals.
34. Check the grass catcher bags frequently for wear or deterioration. Replace with new bags for safety protection.
35. Do not operate the Mower without either the entire grass catcher, on mowers so equipped, or the deflector shield in place.



LOOK FOR THIS SYMBOL TO POINT OUT IMPORTANT SAFETY PRECAUTIONS. IT MEANS-ATTENTION! BECOME ALERT! YOUR SAFETY IS INVOLVED.

To assemble and adjust your Tractor you will need:
one 7/16", 9/16" and 3/4" Wrenches.

NOTE: Right Hand (R.H.) and Left Hand (L.H.) are determined from operator's position while sitting on seat of tractor.

ASSEMBLY

1. Remove Shipping Wires, Battery, Steering Wheel and Bag of Parts.
2. Filling and charging Battery (before installing): NOTE: SEE DETAILED INSTRUCTIONS PACKAGED WITH BATTERY.



WEAR EYE AND FACE SHIELD.

- a. Fill Battery with electrolyte to bottoms of tubes in cells (Fig. 1). NOTE: DO NOT OVERFILL. OVERFILLING WILL RESULT IN DAMAGE TO TRACTOR.



WASH HANDS OR CLOTHING IMMEDIATELY IF ACCIDENTALLY IN CONTACT WITH ELECTROLYTE.

- b. Check level of electrolyte after 30 minutes. Add additional electrolyte if necessary. NOTE: Tighten Vent securely.
- c. Charge Battery at a rate not exceeding three amperes for about two and one half hours.



DO NOT SMOKE. FUMES FROM CHARGED ELECTROLYTE ARE EXPLOSIVE.

- d. Neutralize excess electrolyte for disposal by adding it to four inches of water in a five gallon plastic container. Stir with a wooden or plastic paddle while adding baking soda until the addition of more soda causes no more foaming.

3. Install Battery using:

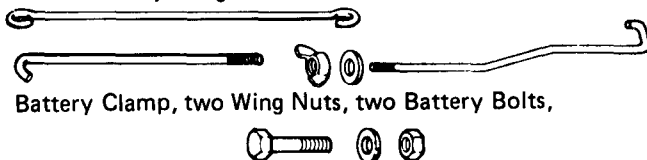

four Flat Washers, two Hex Bolts and two Hex Nuts found in Bag of Parts.

- a. Push down and slightly spread rear sides of Hood to release Hood Latches. Lift Hood from rear sides (Fig. 2).
- b. Remove tape from Plastic Tray. Position Plastic Tray so that drain hole in Tray is over round hole of Battery Support.
- c. Place Battery in Plastic Tray (Battery Terminals to front of Tractor) (Fig. 3).
- d. Hook the curved shank Battery Bolt into slot on the left side of Battery Support (Fig. 3). Fasten Battery Clamp to Battery Bolt with a Flat Washer and Wing Nut.
- e. Hook the straight shank Battery Bolt into slot in R.H. Hood Latch and fasten Battery Clamp with a Flat Washer and Wing Nut (Fig. 4). Tighten Wing Nuts securely.
- f. Place a Flat Washer over the end of a Hex Bolt. Secure RED Battery Cable to Positive (+) Battery Terminal with a Hex Bolt (Washer) and Hex Nut (Fig. 5). Tighten Nut securely. Place Boot over Terminal.



POSITIVE TERMINAL MUST BE CONNECTED FIRST TO PREVENT SPARKS FROM ACCIDENTAL GROUNDING.

- g. Place remaining Flat Washer over the end of the remaining Hex Bolt. Secure BLACK Ground Cable to Negative (-) Battery Terminal with Hex Bolt (Washer) and Hex Nut (Fig. 5). Tighten Nut securely.

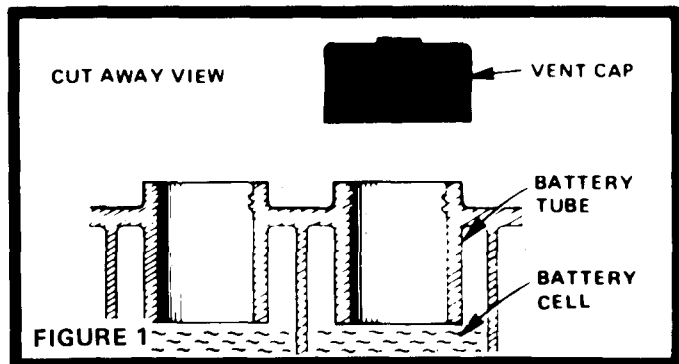

FIGURE 1

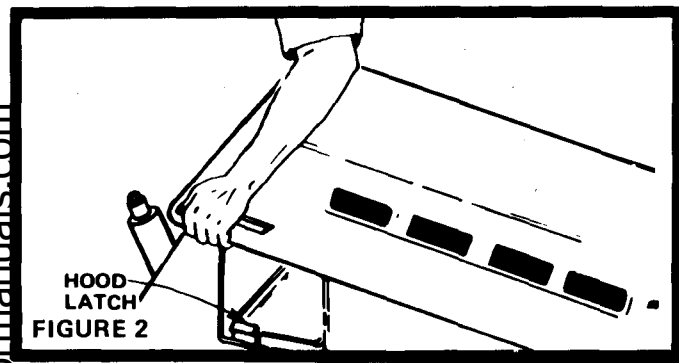

FIGURE 2

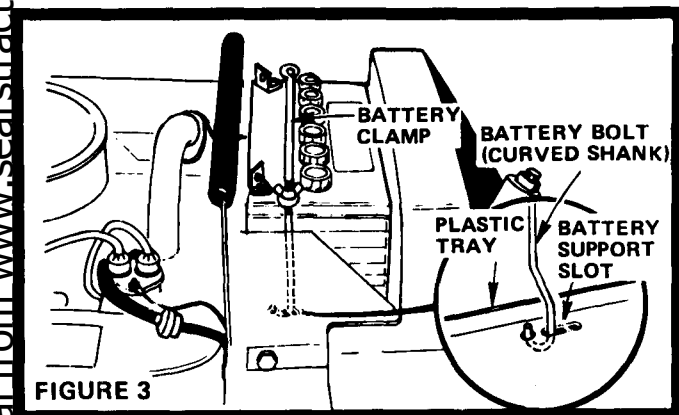

FIGURE 3

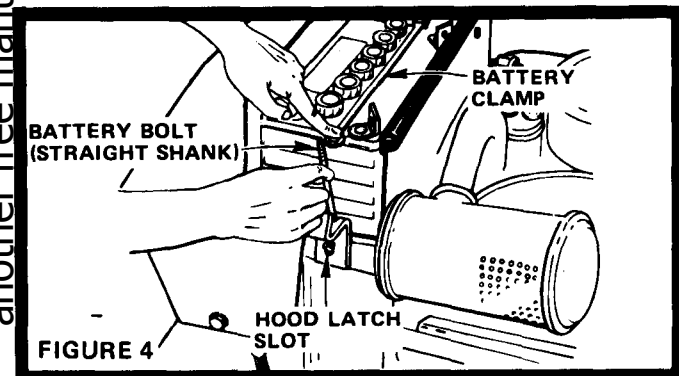

FIGURE 4

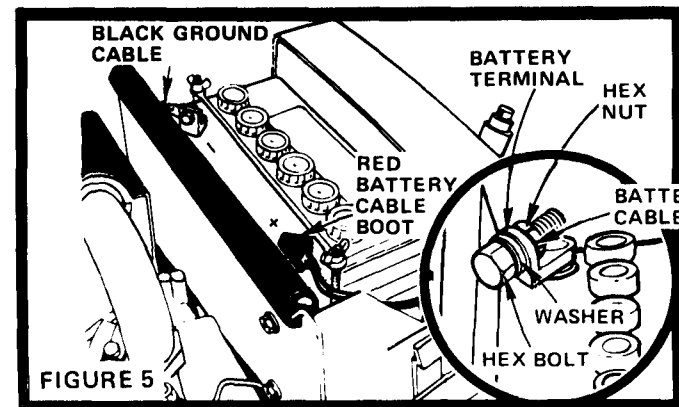

FIGURE 5

4. Install Steering Wheel using:



Flat Washer, Lockwasher and Hex Bolt assembled on end of Steering Shaft.



Woodruff Key, and Steering Wheel Insert found in Bag of Parts.

- Remove Hex Bolt, Lockwasher and Flat Washer from Steering Shaft (Fig. 6).
- Insert Woodruff Key in Keyway of Steering Shaft and slide Steering Wheel over Shaft and Key. NOTE: BE SURE WOODRUFF KEY IS SECURE IN STEERING SHAFT.
- Fasten with Flat Washer, Lockwasher and Hex Bolt (Fig. 6). Tighten securely.
- Press Steering Wheel Insert in place.

THIS TRACTOR IS EQUIPPED WITH SAFETY SWITCHES TO PREVENT STARTING OF THE TRACTOR ENGINE WHILE THE ATTACHMENT CLUTCH PEDAL IS IN THE "ON" POSITION (FIG. 10) AND THE CLUTCH BRAKE PEDAL IS IN DRIVE POSITION (FIG. 12).

IMMEDIATELY REPLACE SWITCHES THAT ARE NOT IN PROPER WORKING ORDER. DO NOT ATTEMPT TO DEFEAT THE PURPOSE OF THESE SWITCHES.



INITIAL ADJUSTMENTS

- Reduce Tire pressure to 12 pounds in front and rear Tires. (Tires were overinflated for shipping purposes).
- Seat position may be adjusted forward or backward by loosening Nut in Seat Plate (Fig. 7). NOTE: WHEN RETIGHTENING NUT AFTER ADJUSTMENT, MAKE SURE SEAT PLATE HAS NOT TWISTED OUT OF ALIGNMENT WITH SEAT SPRING.

INITIAL SERVICE

NOTE: BE CAREFUL NOT TO ALLOW DIRT TO ENTER THE ENGINE WHEN CHECKING OR ADDING OIL OR FUEL.

- Check Engine Oil Level with Tractor on level ground. Wipe dipstick (Fig. 7) clean, screw it in tight for a few seconds, remove and read Oil Level. If necessary, add Oil until "FULL" mark is reached. In summer use S.A.E. 30 (SC, SD or SE) Oil. In winter (below 32°F.) use S.A.E. 10W30 (SC, SD or SE) or 10W40 (SC, SD or SE). In extreme cold (below 0°F.) use S.A.E. 5W20 (SC, SD or SE). NOTE: DO NOT OVERFILL.
- Fill Fuel Tank (Fig. 7) with fresh regular grade lead-free or leaded gasoline. Capacity is 3 - 1/4 gallons. NOTE: DO NOT SWITCH FROM LEADED TO LEAD-FREE GASOLINE.



FILL TO BOTTOM OF GAS TANK FILLER NECK. DO NOT OVERFILL. WIPE OFF ANY SPILLED OIL OR FUEL.

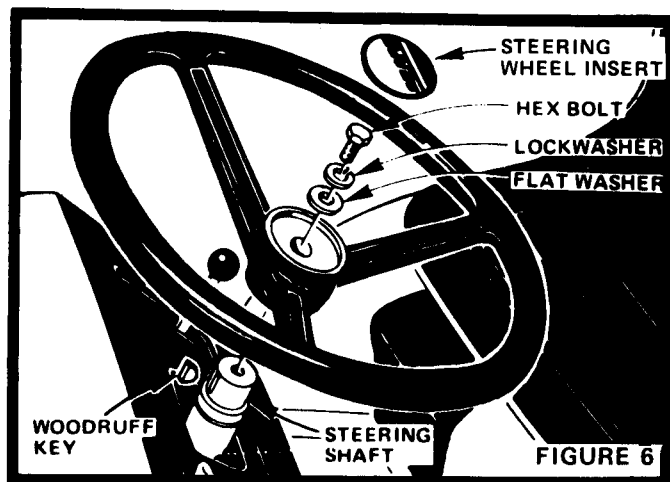

FIGURE 6

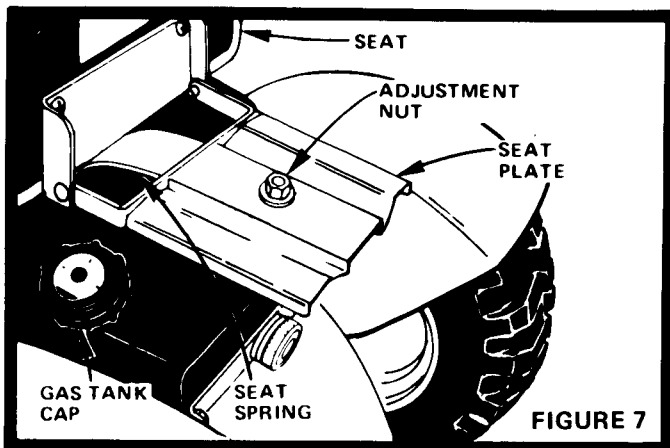

FIGURE 7

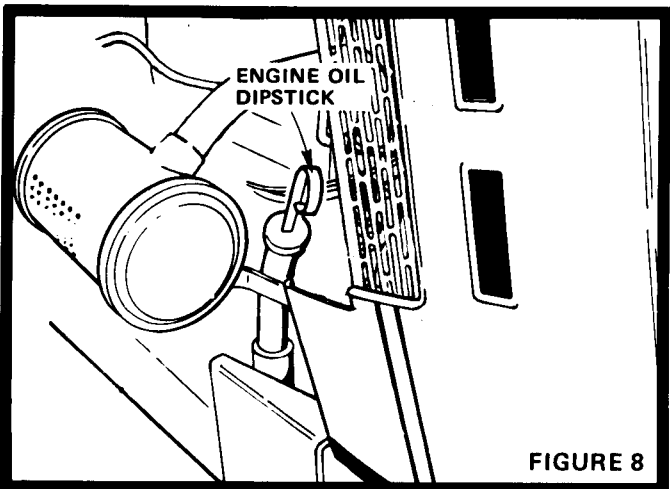

FIGURE 8

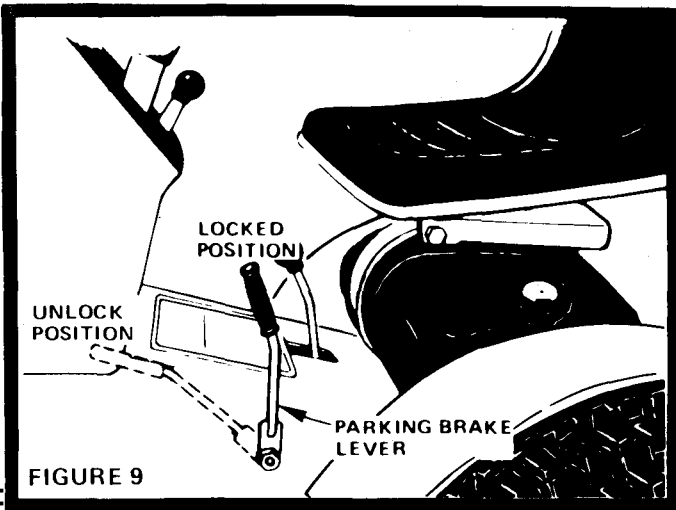

FIGURE 9

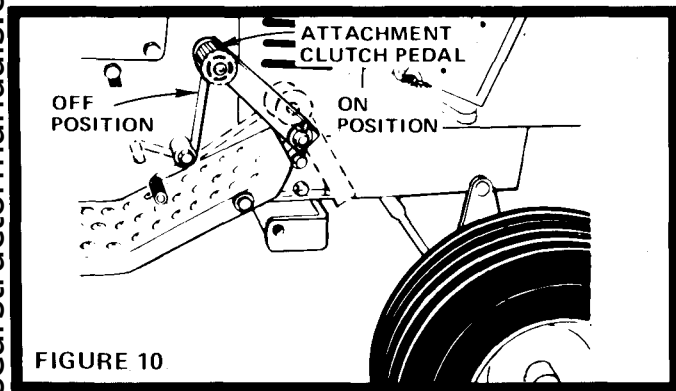

FIGURE 10

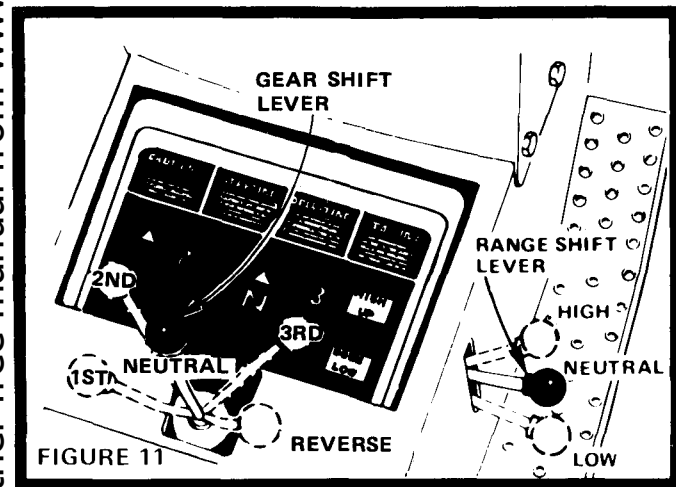

FIGURE 11

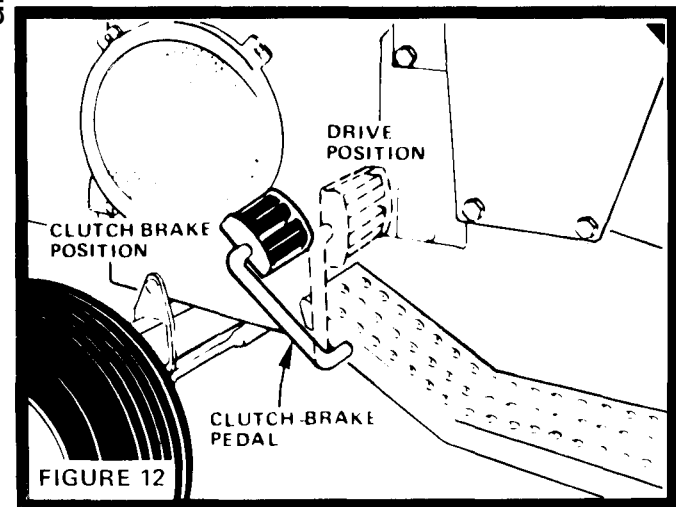

FIGURE 12

OPERATION



CAUTION

1. Keep all shields in place.
2. Before leaving operator's position:
 - a. Shift transmission to neutral
 - b. Set parking brake
 - c. Disengage attachment clutch
 - d. Shut off engine
 - e. Remove ignition key
3. Wait for all movement to stop before servicing machine.
4. Keep people and pets a safe distance away from machine.

STARTING THE ENGINE

1. Place Parking Brake Lever in locked position (Fig. 9).
2. Place Attachment Clutch Pedal in "OFF" position (Fig. 10).
3. Place Gear Shift Lever in neutral "N" position (Fig. 11).
4. Move Range Shift Lever to "N" neutral position (Fig. 11).
5. Push Clutch-Brake Pedal into brake position (Fig. 12).
6. Move Throttle Control Lever to middle position (Fig. 13).
7. Pull Choke out (Fig. 13).
8. Turn Ignition Key to "START" position until Engine starts (Fig. 13). Release key into "ON" position.

NOTE: DO NOT RUN STARTER CONTINUOUSLY FOR MORE THAN THIRTY SECONDS AT A TIME. If engine does not start after several attempts, move Throttle Control Lever to "FAST" position, wait a few minutes, and try again.

NOTE: The Electric Lift Switch (Fig. 13) raises or lowers an attachment when used with an Electric Three Point Hitch (optional equipment).

WARMING UP THE ENGINE

Move Throttle Control Lever to slow position. Push Choke in as engine warms. NOTE: ALLOW ENGINE TO WARM UP FOR A FEW MINUTES BEFORE OPERATING.

When restarting a warm engine, move Throttle Control Lever to middle position, Choke may not have to be used.

ALWAYS WEAR SUBSTANTIAL FOOTWEAR AND AVOID LOOSE FITTING CLOTHING THAT COULD GET CAUGHT IN MOVING PARTS.



LEARN TO START, STOP AND REVERSE YOUR TRACTOR IN A LARGE, OPEN SPACE.

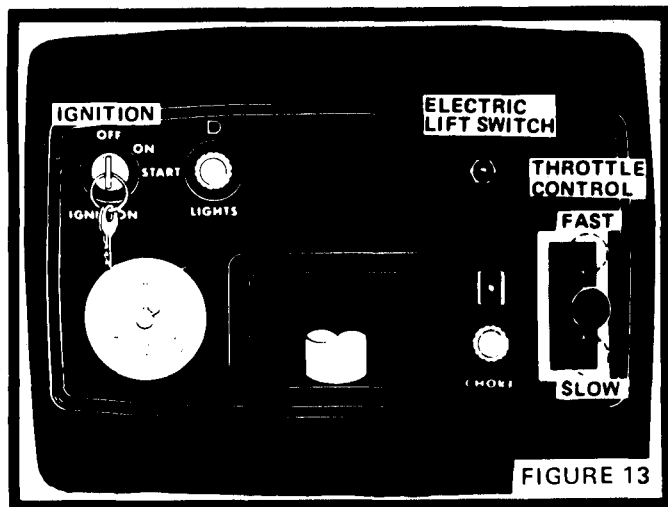

FIGURE 13

TRACTOR OPERATION

1. With engine running and warm, place Throttle Lever in middle position.
2. Push Clutch-Brake Pedal down to brake position.
3. Move Gear Shift Lever to "2ND" and Range Shift Lever to "LOW".
4. Unlock Parking Brake.
5. Release Clutch-Brake Pedal SLOWLY to start forward movement.
6. If ground travel is too slow move Throttle Lever to fast position or press Clutch-Brake pedal and shift to a different gear. NOTE: ALWAYS SELECT A GROUND TRAVEL SPEED THAT WILL SUIT THE TERRAIN AND THE ATTACHMENT BEING USED.

BRING TRACTOR TO COMPLETE STOP BEFORE SHIFTING GEARS.



NEVER PLACE YOUR HANDS OR FEET IN OR UNDER ANY POWERED ATTACHMENT OR NEAR ANY MOVING PART WHILE TRACTOR OR ANY POWERED ATTACHMENT IS RUNNING.



DO NOT OPERATE THE MOWER WITHOUT EITHER THE ENTIRE GRASS CATCHER, ON MOWERS SO EQUIPPED, OR THE DEFLECTOR SHIELD IN PLACE.

STOPPING YOUR TRACTOR

1. Reduce Throttle Lever to "SLOW" position.
2. Push Clutch-Brake Pedal into Brake position.
3. Place Attachment Clutch Pedal in "OFF" position and lower attachment to the ground.
4. Move Gear Shift Lever to neutral "N".
5. Place Parking Brake in "LOCK" position.
6. Release Clutch-Brake Pedal.



MAKE SURE PARKING BRAKE WILL HOLD TRACTOR SECURE.

7. Turn Ignition Key to "OFF" position.



REMOVE KEY WHEN LEAVING TRACTOR TO PREVENT UNAUTHORIZED USE.

TRANSPORTING YOUR TRACTOR

For pushing or towing your tractor, place Gear Shift Lever and Range Shift Lever in neutral position (Fig. 11). NOTE: DO NOT TOW YOUR TRACTOR FASTER THAN SIX MILES PER HOUR.

TRACTOR OPERATION ON HILLS

1. Choose one of the lowest gears BEFORE starting up or down hills.



DO NOT DRIVE UP OR DOWN HILLS WITH SLOPES GREATER THAN 15°, AND DO NOT DRIVE ACROSS ANY SLOPE.

2. Avoid shifting or stopping on hills.
 - a. If slowing is necessary, move Throttle Control to middle position.
 - b. If stopping is necessary, push Clutch-Brake Pedal quickly to brake position to prevent rolling.
 - c. Engage Parking Brake and shift to lowest speed range.
 - d. Partially release Clutch-Brake Pedal (until forward movement begins).
 - e. Release Parking Brake.
 - f. Completely release Clutch-Brake Pedal.
3. Make all turns gradually.

STARTING YOUR TRACTOR WITH A LOW BATTERY

If your Battery is too low to start the engine, it should be recharged. If "Jumper Cables" are used for emergency starting follow this procedure. NOTE: YOUR TRACTOR IS EQUIPPED WITH A 12 VOLT NEGATIVE GROUNDED SYSTEM. THE OTHER VEHICLE MUST ALSO BE A 12 VOLT NEGATIVE GROUNDED SYSTEM.



LEAD-ACID BATTERIES GENERATE EXPLOSIVE GASES. KEEP SPARKS, FLAME, AND SMOKING MATERIALS AWAY FROM BATTERIES. ALWAYS SHIELD EYES AROUND BATTERIES.

1. Connect each end of the RED cable to the POSITIVE (+) terminals of each battery (taking care not to short against chassis).
2. Connect one end of the BLACK cable to the NEGATIVE (-) terminal of "GOOD" battery.
3. Connect the other end of the cable to ENGINE BLOCK of good CHASSIS GROUND on tractor (away from Gas Tank or Battery).
4. Disconnect cables in reverse order:
 - a. Engine Block or chassis.
 - b. Negative terminal of "GOOD" battery.
 - c. Positive terminals.



DO NOT USE YOUR TRACTOR BATTERY TO START OTHER VEHICLES.

MAINTENANCE

To keep your tractor running better, longer; perform necessary service using the following Maintenance Schedule and the Service Hour Meter (Fig. 14) on the dash.

The Service Hour Meter records the number of hours of tractor operation. Read the Hour Hand on the outer dial; each mark indicating one hour of operation. Read the Sixty Hour Hand on the inner dial; each mark indicating sixty hours of operation. The System Indicator moves visibly when the Ignition Key is in the "ON" position, indicating the system operational. NOTE: The System Indicator will continue to move for a short period of time after the ignition is shut off.

DISCONNECT SPARK PLUG WIRES TO PREVENT ACCIDENTAL STARTING BEFORE MAKING ANY INSPECTION, ADJUSTMENT (EXCEPT CARBURETOR) OR REPAIR.



FIRST 2 HOURS:

1. CHECK V-BELT TENSION

A new V-Belt may stretch after the first few hours of operation. If Clutch-Brake Pedal, in drive position (Fig. 15), is considerably to the front or rear of the vertical position, the V-Belt is out of adjustment and must be re-tensioned.

- Secure Clutch-Brake pedal in brake position (relaxing V-Belt tension) by tying to front axle.
- Hold Nut on inside of Flat Idler and loosen Flat Idler Bolt.
- Move Flat Idler in frame slot 1/4 inch down (to tighten), up (to loosen) V-Belt tension. Tighten Bolt.
- Release Clutch-Brake Pedal. It should return to approximately vertical position.



CHECK TO MAKE SURE TRACTOR DOES NOT START WITHOUT FULLY DEPRESSING CLUTCH-BRAKE PEDAL.

NOTE: FOR LONGER V-BELT LIFE, ALWAYS KEEP BELT TENSIONED PROPERLY. START TRACTOR MOVEMENT WITH THROTTLE CONTROL IN MIDDLE POSITION, AND ALWAYS REPLACE WITH SEARS V-BELTS.

2. CHANGE ENGINE OIL

Changing Oil after the first two hours will help eliminate break-in residue which might be damaging to your Engine.

Note: Be careful not to allow dirt to enter the Engine when changing oil.

- Drain Oil with Engine warm. Unscrew Oil Drain Cap (Fig. 16) and catch Oil in a suitable container. Replace Cap.
- Refill Engine Oil (Fig. 17). In summer use S.A.E. 30 (SC, SD or SE) Oil. In winter (below 32°F.) use S.A.E. 10W30 (SC, SD or SE) or 10W40 (SC, SD or SE). In extreme cold (below 0°F.) use S.A.E. 5W20 (SC, SD or SE). Capacity is 3 - 1/2 pints. NOTE: DO NOT OVER-FILL.

FREQUENTLY:

1. CHECK BATTERY

- Electrolyte solution level in each Battery Cell should be even with bottoms of tubes in cells (Fig. 18). Add distilled water if necessary. NOTE: DO NOT OVERFILL.
- Keep Battery and Terminals clean. Refer to page 10.
- Keep Battery bolts tight.
- Keep Vent Caps tight and small Vent holes in caps open.
- Recharge SLOWLY at 3 amperes if specific gravity of electrolyte falls below 1.225.

2. CHECK TIRE PRESSURE

Tire pressure in front and rear Tires should be 12 pounds.

3. CLEAN AIR SCREEN

Air Screen and Guard (Fig. 21) must be kept free of dirt and chaff to prevent Engine damage from overheating.

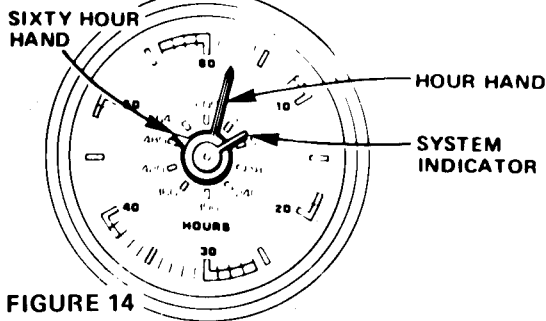

FIGURE 14

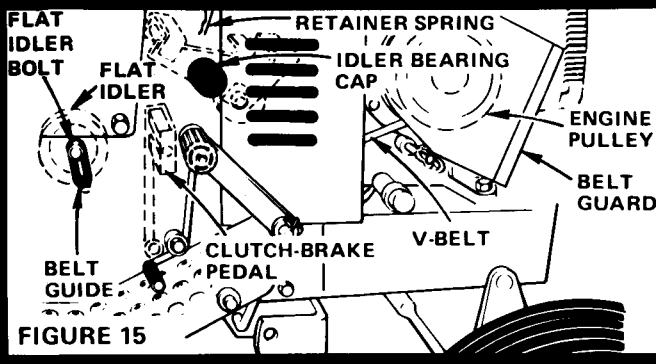

FIGURE 15

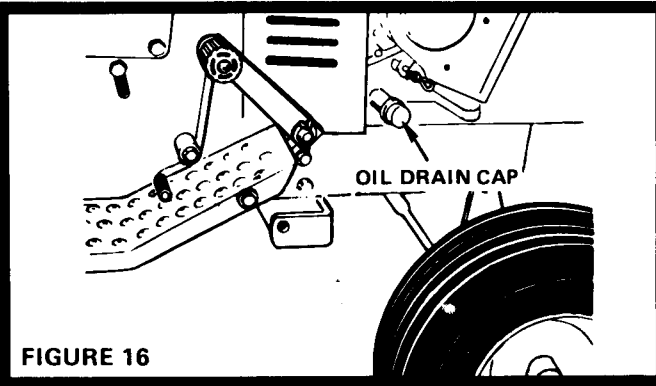

FIGURE 16

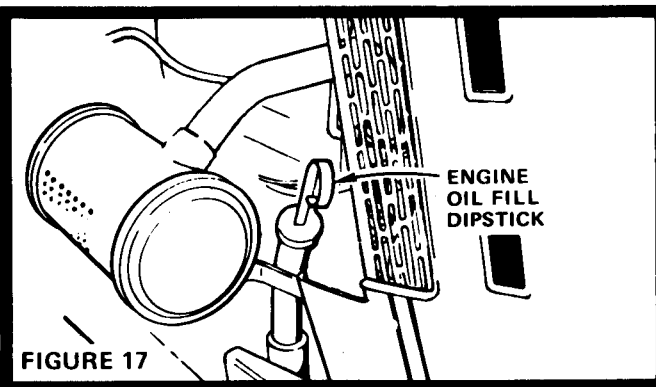

FIGURE 17

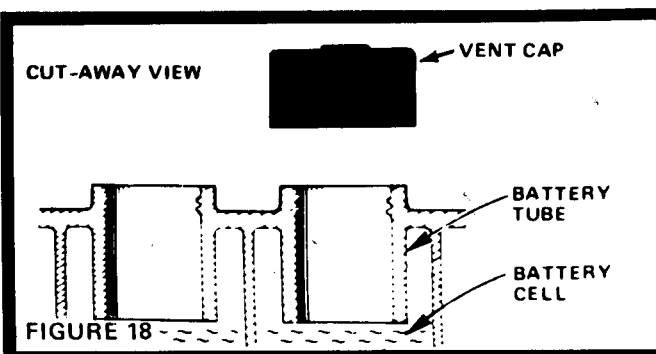

FIGURE 18

EVERY 5 HOURS:

1. CHECK ENGINE OIL LEVEL



DO NOT CHECK ENGINE OIL LEVEL WITH ENGINE RUNNING.

Several minutes after stopping Engine, check Engine Oil Level with Tractor on level ground. Wipe dipstick (Fig. 17) clean, push it down tight for a few seconds, remove and read Oil Level. If necessary, add Oil until "FULL" mark is reached. In summer use S.A.E. 30 (SC, SD or SE) Oil. In winter (below 32°F.) use S.A.E. 10W30 (SC, SD or SE) or 10W40 (SC, SD or SE). In extreme cold (below 0°F.) use S.A.E. 5W20 (SC, SD or SE). NOTE: DO NOT OVER-FILL.

2. LUBRICATE STEERING AND FRONT WHEELS

There are six Grease Fittings on your Tractor (Fig. 19). Using a Grease Gun, give each Grease Fitting two shots of Extreme Pressure Lubricating Grease Amdex No. 1 (Available at your local Sears Service Center).

3. OIL PIVOT POINTS

Place several drops of SAE 30 Oil at points where parts move against each other, especially:

a. Idler Bearing (Fig. 15)

- Remove Plastic Cap.
- Remove Retainer Spring from Idler Shaft.
- Move Idler and Shaft outward and lubricate exposed Shaft.
- Return Idler and Shaft to original position, replace Retainer Spring and reposition Cap.

b. Front Axle Pivot (Fig. 19)

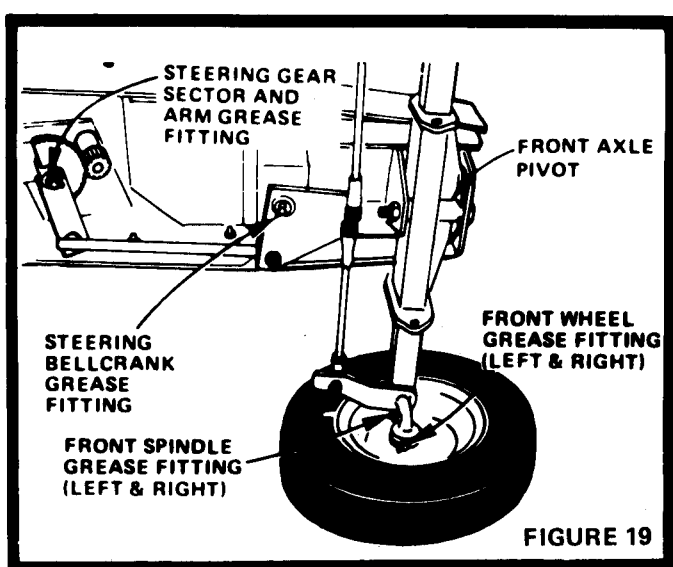

FIGURE 19

EVERY 25 HOURS: (EVERY 15 HOURS IF OPERATING IN VERY DUSTY CONDITIONS)

1. CLEAN AIR FILTER & FOAM PRE-CLEANER

- a. Unscrew Wing Nut (Fig. 20) to remove Air Filter Cover, Paper Air Filter Element and Foam Pre-Cleaner.
 - b. Clean dust from Paper Air Filter Element by gently tapping Element on a flat surface.
 - c. Wash Foam Pre-Cleaner in detergent and water.
 - d. Rinse, squeeze (rather than twist) and allow to dry thoroughly.
 - e. Coat with three tablespoons of S.A.E. 30 Engine Oil, knead to distribute evenly, and squeeze out excess.
 - f. Check Paper Air Filter Element. Replace if excessively dirty.
 - g. Re-Assemble Air Filter and re-position on Tractor.
- NOTE: NEVER RUN ENGINE WITH AIR CLEANER REMOVED.

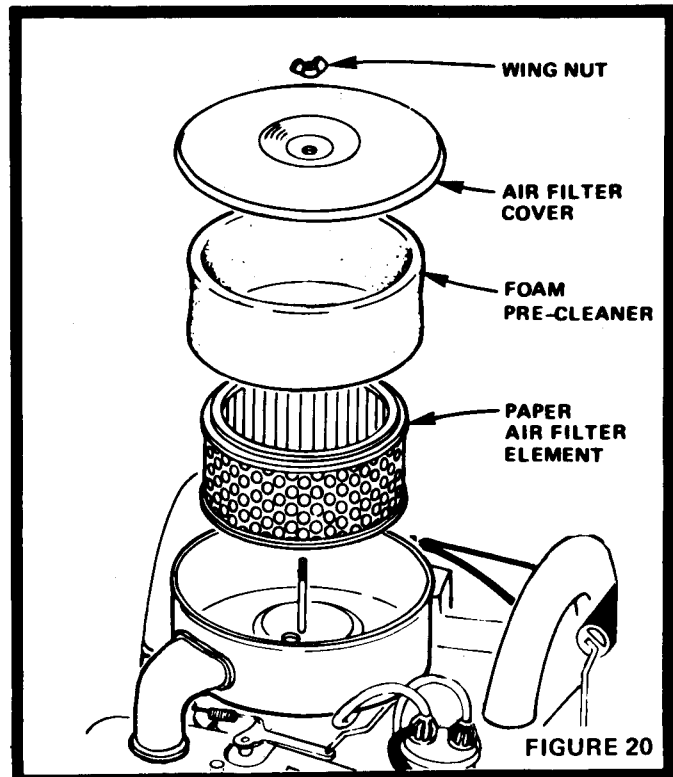

FIGURE 20

2. CLEAN AIR SCREEN

Air Screen and Guard (Fig. 21) must allow free-flow of air to prevent Engine damage from overheating. Remove Air Screen and Guard and clean with a wire brush to remove dirt, chaff, stubborn dried gum and fibers.

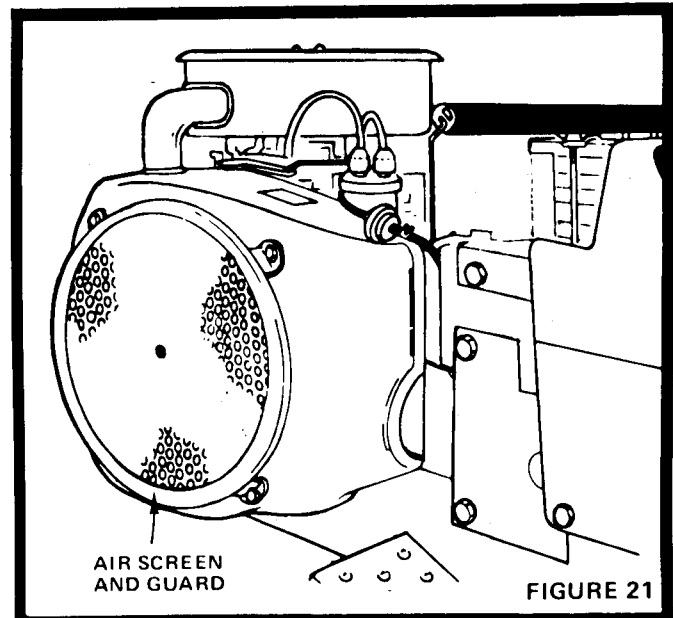

FIGURE 21

3. CHANGE ENGINE OIL

The best time to change Engine Oil is at the end of a days operation when all dirt and foreign material is suspended in the hot Oil. Refer to page 6.

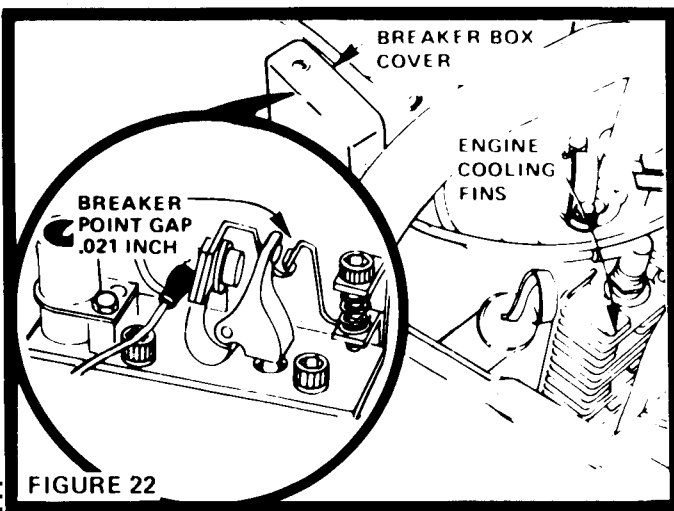

FIGURE 22

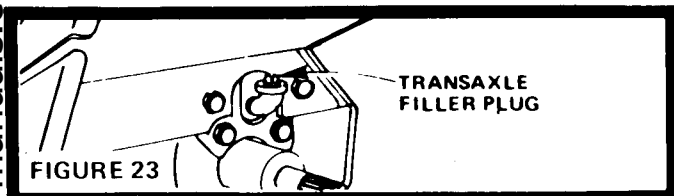

FIGURE 23

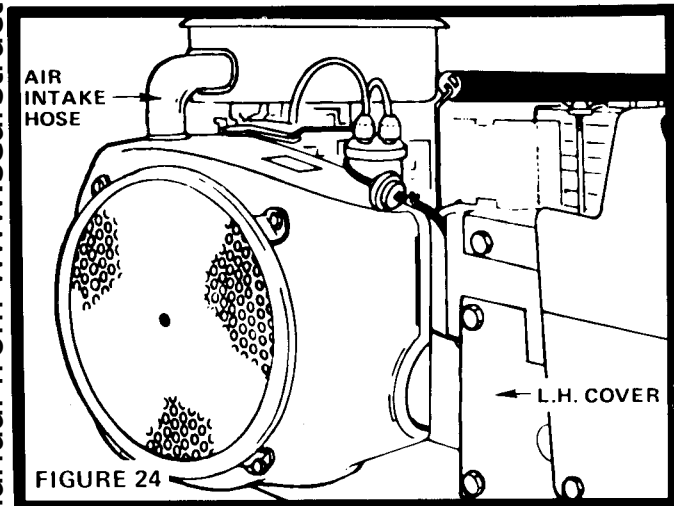

FIGURE 24

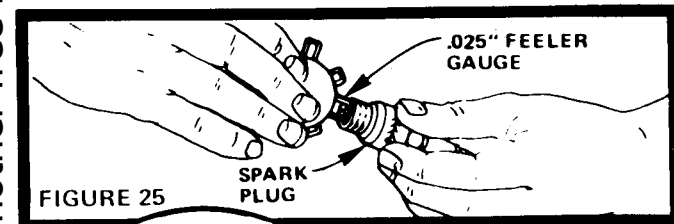

FIGURE 25

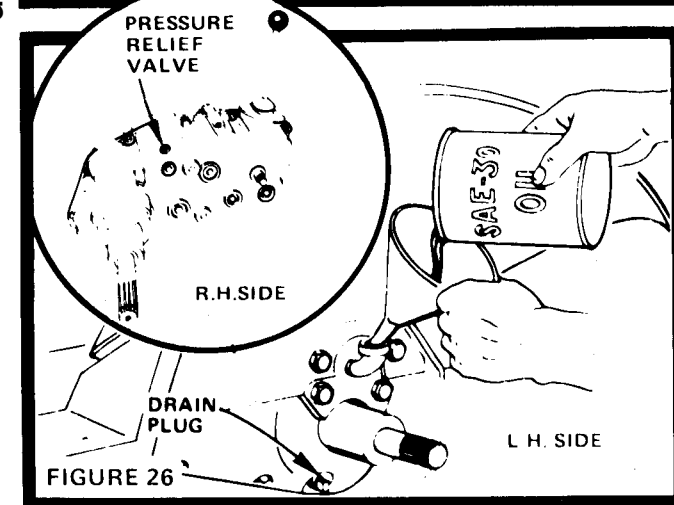

FIGURE 26

EVERY 50 HOURS:

1. CLEAN ENGINE COOLING FINS

Remove any dust, dirt or oil from Engine Cooling Fins (Fig. 22) to prevent Engine damage from overheating.

2. CHECK TRANSAXLE OIL LEVEL

- Block up Rear Axle securely or use a Tractor Jack. Remove left rear wheel by removing E-Ring (Fig. 33).
- Remove Filler Plug (Fig. 23) from Transaxle. Oil Level should be even with Filler Plug threads. Add S.A.E. 30 Motor Oil if necessary.
- Check Pressure Relief Valve located on R.H. side near top (Fig. 26). It should spring completely closed when pulled out by hand and released.
- Reposition wheel. Secure with E-Ring.

EVERY 100 HOURS:

- Replace both Spark Plugs at the beginning of each mowing season, or every 100 hours of operation, whichever comes first.

2. CHECK BREAKER POINTS

Replace Points if they are pitted or burned.

- Remove Air Intake Hose that connects to Blower Housing (Fig. 24). This provides an access to view Timing Mark.
- Remove Spark Plugs and Belt Guard and turn Engine Pulley (Fig. 15) clockwise by hand until 21°BTC mark on gear cover aligns with mark on flywheel. Turn another 1/4 turn to ensure points are fully open.
- Remove Breaker Box Cover (Fig. 22) by loosening Screw and lift off to remove.
- Replace Points, if necessary.
- Using an Allen Wrench, adjust Set Screw for .021 inch between Points. Measure point gap with a Flat Feeler Gauge. NOTE: MAKE SURE FEELER GAUGE IS CLEAN AND FREE OF GREASE, OIL, OR DIRT. No other adjustment or alignment is necessary. Setting point gap accurately adjusts Engine Timing.
- Replace Breaker Box Cover, Spark Plugs and Cables and Air Intake Hose.

3. LUBRICATE BALL JOINTS

- Move Rubber Boots to expose Ball Joints on Tie Rods and Steering Link (Fig.28).
- Coat Ball Joints with Silicone Spray Lubricant.
- Reposition Rubber Boots.

EVERY 200 HOURS:

1. REPLACE PAPER AIR FILTER ELEMENT

Refer to page 7.

2. REPLACE BREAKER POINTS

Refer to step 2, above.

EVERY 480 HOURS:

CHANGE TRANSAXLE OIL

- Block up Rear Axle securely or use a Tractor Jack. Remove Left Rear Wheel by removing E-Ring (Fig. 33).
- Drain Transaxle Oil by removing Drain Plug (Fig. 26) and catching Oil in suitable container. Replace Drain Plug.
- Refill Transaxle with S.A.E. 30 (SC, SD or SE) Motor Oil. Capacity is 5 quarts. Pressure Relief Valve (R.H. side of Transaxle, Fig. 26, Inset) may be held open to allow Transaxle to fill more quickly.
- Check Pressure Relief Valve. It should spring completely closed when pulled out by hand and released.
- Reposition wheel. Secure with E-Ring.

AS NEEDED

1. REPLACE IN-LINE FUEL FILTER

If fuel filter is clogged, obstructing fuel flow to carburetor, replacement is required.

- With Engine cool, remove and plug Fuel Line Sections as removed from both ends of Fuel Filter (Fig. 27).
- Place new Fuel Filter in position in Fuel Line.



BE SURE THERE ARE NO FUEL LINE LEAKS AND THAT FUEL LINE IS IN PROPER POSITION IN HOSE CLAMPS.

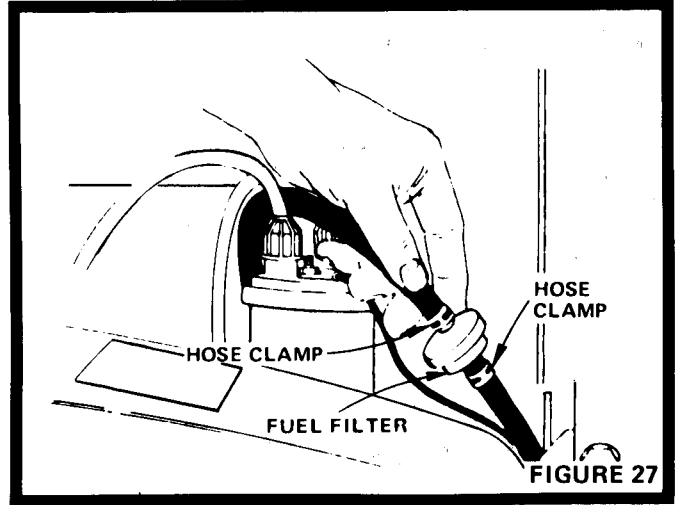

FIGURE 27

2. TOE-IN ADJUSTMENT

If any parts in Front Axle or Steering Mechanism are being replaced, Tie Rod adjustment is required.

- Loosen Jam Nuts (Fig. 28) at each end of Tie Rod Adjustment Sleeves.
- Adjust both Tie Rods so that Tie Rod Joints measure from 10 to 10 - 1/8 inches from center to center.
- Tighten Jam Nuts, making sure Tie Rod Joints are parallel (180°) to each other. This adjustment secures proper Front Wheel toe-in and steering operation.

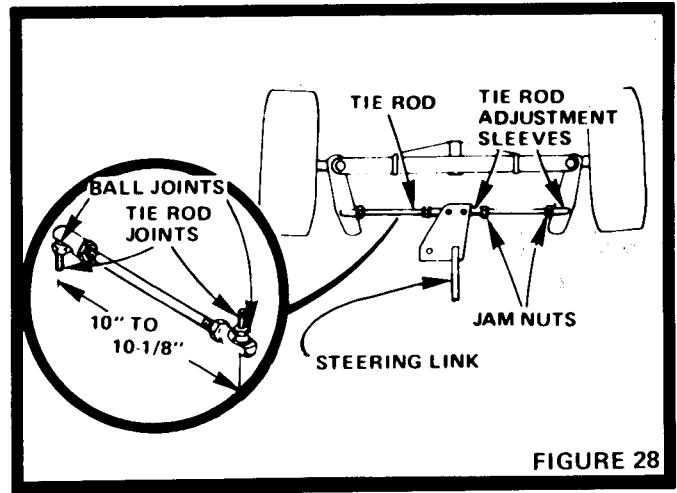

FIGURE 28

3. BRAKE ADJUSTMENT

If Clutch-Brake Pedal (Fig. 29) has more than approximately 4 inches of travel from vertical to full brake position then brake adjustment is necessary.

- Loosen Jam Nut (Fig. 29) in order to turn turnbuckle clockwise (from in front of tractor) one turn at a time until Clutch-Brake Pedal regains 4 inches of travel.
- Tighten Jam Nut against Turnbuckle.

4. PARKING BRAKE ADJUSTMENT

If Parking Brake will not hold tractor, Parking Brake adjustment is necessary.

- Loosen Parking Brake Hex Nuts (Fig. 29).
- Place Parking Brake Lever in locked position.
- Hold Clutch-Brake Pedal in brake position and tighten first Hex Nut finger tight against Bushing.
- Release Clutch-Brake Pedal and turn first Hex Nut two turns more against Bushing.
- Tighten second Hex Nut against first Hex Nut.

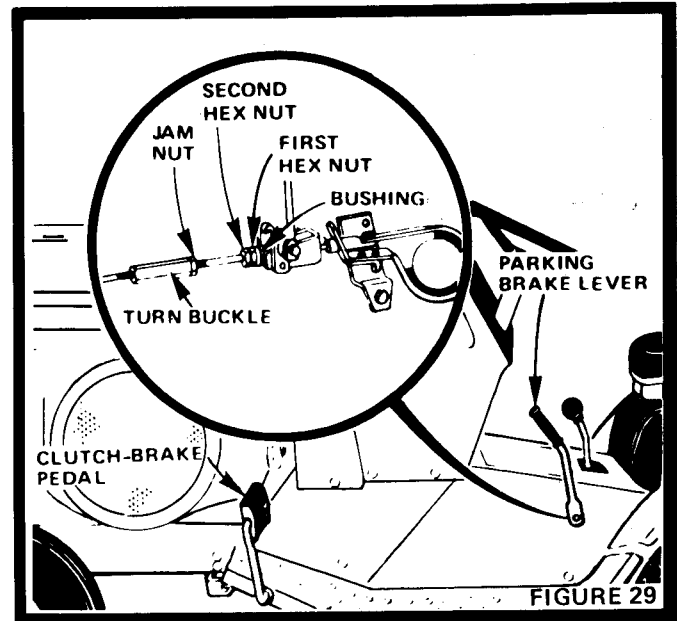

FIGURE 29

5. CARBURETOR ADJUSTMENT

If engine lacks power or does not idle properly, the Carburetor may need adjustment.

- Main Fuel (High Speed) Screw (Fig. 30) should not require adjustment. If resetting is necessary, turn clockwise, closing finger tight ONLY, then turn counterclockwise 1 - 1/2 to 1 - 3/4 turns.
- Turn Idle Adjusting Needle (Fig. 30) clockwise, closing finger tight ONLY, and then turn counterclockwise 1 to 1 - 1/4 turns.



REFER TO "STARTING THE ENGINE" PAGE 4.

- Start Engine and allow to warm for five minutes. Make final adjustments with Engine running.

-- Turn Idle Adjusting Needle counterclockwise until Engine runs "rough" then clockwise until Engine begins to miss. Return Screw to a point midway between these extremes.

-- Throttle Stop Screw (Fig. 30) should not require adjustment. If resetting is necessary, set to obtain the slowest engine speed that will allow smooth acceleration.

6. RE-TENSION V-BELT

It may be occasionally necessary to re-tension V-Belt. (See page 6).



CHECK TO MAKE SURE TRACTOR DOES NOT START WITHOUT FULLY DEPRESSING CLUTCH-BRAKE PEDAL.

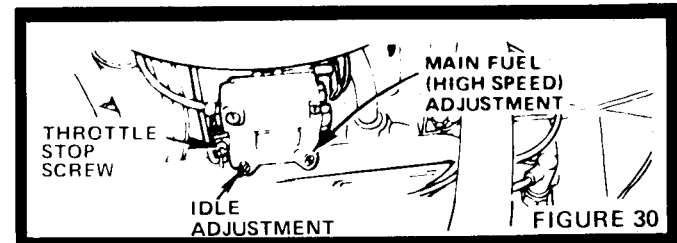

FIGURE 30

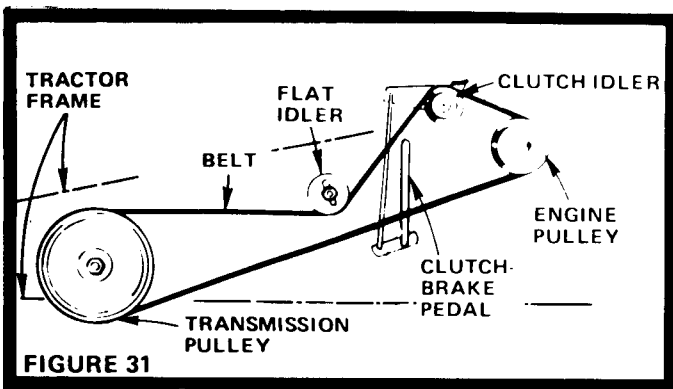

FIGURE 31

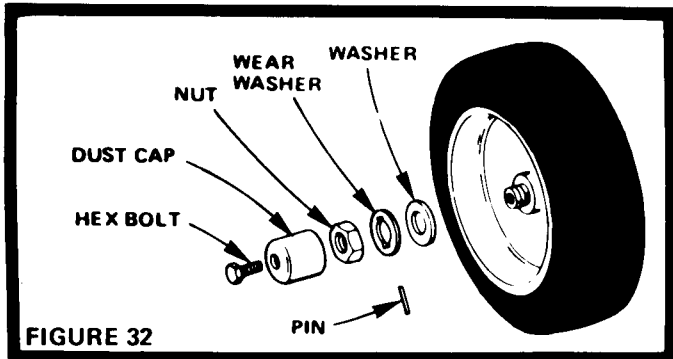

FIGURE 32

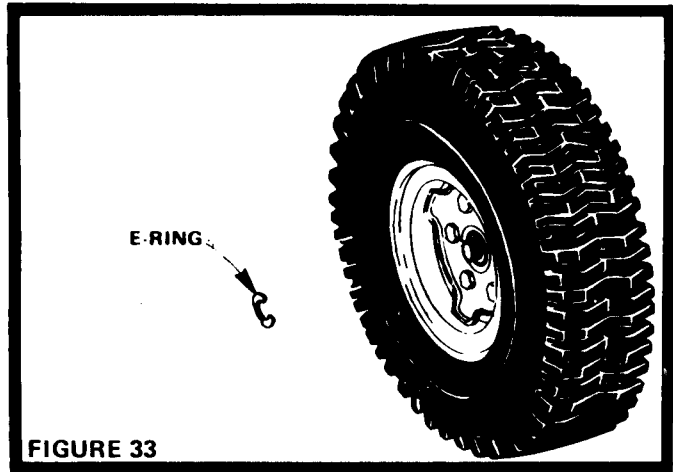

FIGURE 33

7. V-BELT REPLACEMENT

- Remove Belt from Clutch Idler by depressing Clutch-Brake Pedal (Fig. 31).
- Remove Belt Guide from Engine Pulley.
- Remove Rear Belt Guide Assembly from Transmission Pulley.
- Loosen Flat Idler Assembly on R.H. side of Tractor Frame.
- Remove Belt from Engine Pulley, between Belt Guide Finger (note position of Belt) and Flat Idler, and Transmission Pulley.
- Place new Belt around Transmission Pulley. Then place Belt between Belt Guide Finger and Flat Idler and then around Engine Pulley.
- Depress Clutch-Brake Pedal and slip Belt over the top of the Clutch Idler.
- Replace Engine Pulley Belt Guide and Transmission Pulley Belt Guide. Tighten Flat Idler Assembly. NOTE: Make sure Belt Guide Finger on Flat Idler is parallel with slot in Tractor Frame.
- Check Belt tension, page 6.

8. CLEAN BATTERY AND TERMINALS

Corrosion and dirt on the Battery and Terminals cause the Battery to "leak" power and hinders the operation of the charger.

- Remove the Battery from the Tractor and wash with four tablespoons of baking soda to one gallon of water. NOTE: BE CAREFUL NOT TO GET THE SODA SOLUTION INTO THE CELLS. Rinse the Battery with plain water, dry and reinstall on Tractor.
- Clean terminals and battery cable ends with a wire brush until bright. Replace Battery Cables. Coat terminal connections with Vaseline.

9. TIRE CARE

- Maintain tire pressure in front and rear tires of 12 pounds.
- Keep tires free of gasoline, oil, or insect control chemicals which can destroy rubber.
- Avoid stumps, stones, deep ruts and other hazards that may cause tire damage.
- Removing front wheel for tire repair (Fig. 32).
 - Block up front axle securely or use a Tractor Jack.
 - Remove Hex Bolt and Dust Cap.
 - Remove Nut, Wear Washer, Pin and Washer to allow wheel removal.
 - Repair tire and reassemble.
- Removing rear wheel for tire repair (Fig. 33).
 - Block up rear axle securely or use a Tractor Jack.
 - Remove E-Ring to allow wheel removal.
 - Repair tire and reassemble. Snap E-Ring securely in axle groove.

10. FINISH

Keep tractor finish and seat free of gasoline, oil, insect chemicals or battery electrolyte. Protect painted surfaces with Automotive type wax.

TROUBLE SHOOTING

POSSIBLE CAUSE

POSSIBLE REMEDY

WILL NOT START

Clutch-Brake Pedal in drive position
Attachment Clutch Pedal in "IN" position
No gasoline in Fuel Tank or clogged Fuel Line
Blown Fuse
Dead Battery

Push Pedal into brake position
Move Pedal to "OUT" position
Fill Tank with Gasoline. Check Fuel Line and Carburetor (clean if necessary)
Check for fault and replace Fuse
Recharge or replace Battery

HARD TO START

Choked improperly, flooded Engine

Clogged Fuel Tank
Dirty Air Cleaner
Spark Plug dirty or improper gap
Defective Battery
Defective Ignition or loose wiring
Water in gasoline or old fuel

Improper Carburetor adjustment

Push Choke in, place Throttle Control in fast position and run starter several times to clear out gas
Remove and clean
Remove and clean
Replace Spark Plug
Recharge or replace
Check the wiring and Spark Plug
Drain Fuel Tank and Carburetor, use fresh fuel and replace Spark Plug
Make necessary adjustments

ENGINE MISSES OR LACKS POWER

Engine overload
Clogged Fuel Tank
Partially plugged Air Cleaner
Improper Carburetor adjustment
Dirty Air Screen
Low oil level or dirty oil
Spark Plug dirty, improper gap or wrong type
Faulty ignition
Poor compression
Oil in gasoline

Shift to a lower gear or reduce load
Remove and clean
Remove and clean
Make necessary adjustments
Clean Air Screen and Cylinder Fins
Add or change oil
Replace Spark Plug
Check Spark Plug and for loose wires
Major Engine overhaul
Drain and refill Gas Tank and Carburetor

ENGINE OVERHEATS

Dirty Air Screen
Low oil level or dirty oil
Dirty Engine
Partially plugged Muffler
Partially plugged Air Cleaner
Stale fuel or improper Carburetor adjustment

Clean Air Screen
Add or change oil
Clean Cylinder Fins
Remove and clean Muffler
Remove and clean
Use fresh fuel and adjust Carburetor

NO LIGHTS

No Headlights with Light Switch Knob pulled out

Check Light Fuse under dash and wire connections.
Replace Sealed Beam Headlights

WON'T CHARGE

Blown Fuse
Defective Battery

Check for fault and replace
Replace

STORAGE

1. ENGINE OIL

Drain (with engine warm) and replace with clean engine oil. Refer to page 6.

2. FUEL SYSTEM

- Drain fuel tank and carburetor by allowing the engine to run out of gasoline. NOTE: GASOLINE LEFT IN YOUR ENGINE WILL LEAVE GUM DEPOSITS CLOGGING FUEL SYSTEM.
- Dispose of gasoline if not to be used. NOTE: GASOLINE STORED FOR SEVERAL MONTHS LOSES ITS VOLATILITY (ABILITY TO BURN EFFECTIVELY).

3. CYLINDER

- Remove Spark Plugs.
- Pour one ounce of oil through spark plug holes into cylinders.
- Turn ignition key to "START" position for a few seconds to distribute oil.
- Replace with new Spark Plugs.

4. BATTERY

- Remove battery if tractor is not used regularly during winter months. Store in cool, dry place (above 50°F). NOTE: DO NOT STORE BATTERY DIRECTLY ON CONCRETE SURFACE.
- Check electrolyte charge each month and recharge if below 1.225 specific gravity. NOTE: BATTERIES NOT IN USE FOR SEVERAL MONTHS AND NOT KEPT FULLY CHARGED, PRODUCE SULPHUR DEPOSITS ON PLATES WHICH CANNOT BE REMOVED BY RECHARGING.

5. GENERAL CLEANING

Clean engine, battery, finish, etc. of all foreign matter.

Sears, Roebuck and Co. reserves the right to make any changes in design or improvements without imposing any obligation to install the same upon its items heretofore manufactured.

REPAIR PARTS

GT 18 TWIN GARDEN TRACTOR--MODEL NO. 917.257111 AND 917.257112

MAIN FRAME, DASH AND GRILL

another free manual from www.searstractormanuals.com

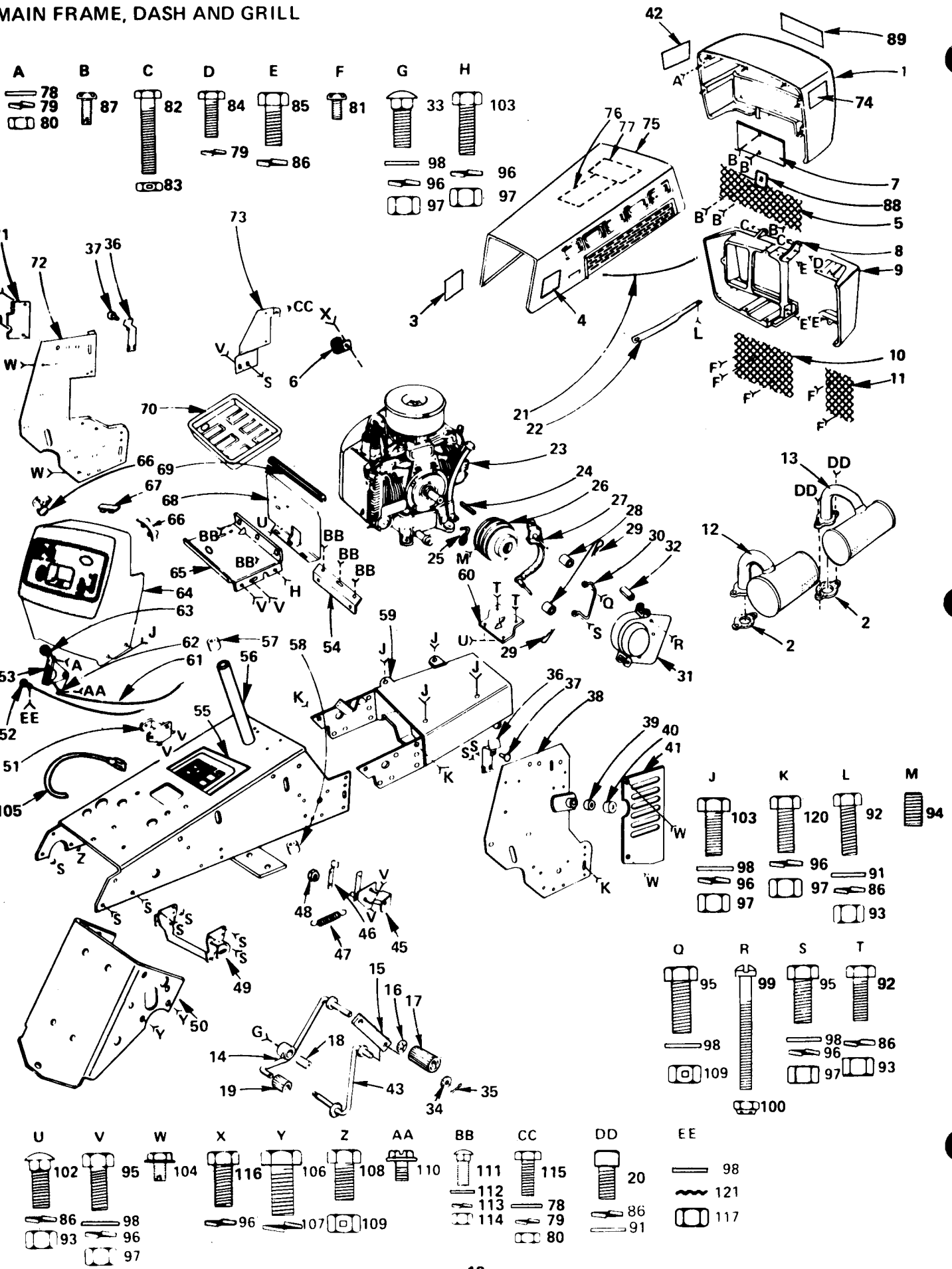

REPAIR PARTS

GT 18 TWIN GARDEN TRACTOR--MODEL NO. 917.257111 AND 917.257112

MAIN FRAME, DASH AND GRILL

| KEY NO. | PART NO. | DESCRIPTION | KEY NO. | PART NO. | DESCRIPTION |
|---------|-----------|-----------------------------------------|---------|-----------|------------------------------------------------------------------------------------------------------------------|
| 1 | 911J | Grill - Upper | 68 | 107J | Battery Heat Shield |
| 2 | 878J | Gasket - Exhaust Manifold | 69 | 7874R | Hood Seal |
| 3 | 1733J | Decal - Hood, L.H. Rear | 70 | 8855R | Battery Tray |
| 4 | 1732J | Decal - Hood, R.H. Rear | 71 | 86J | Cover - L.H. |
| 5 | 2794R | Grill Screen - Center | 72 | 113J | Bracket - Battery Support - L.H. |
| 6 | 2751R | Clip | 73 | 1181J | Bracket - Rectifier |
| 7 | 290J | Grill Panel - Upper | 74 | 1598J | Decal - Grill, R.H. |
| 8 | 7937R | Grill - Lower | 75 | 634A907 | Hood Ass'y. |
| 9 | 7938R | Grill Side | 76 | 8028R | Decal - Instruction |
| 10 | 2674R | Grill Screen - L.H. | 77 | 9880R | Decal - Wiring |
| 11 | 2673R | Grill Screen - R.H. | 78 | STD551025 | *Washer 9/32 x 5/8 x 16 Ga. |
| 12 | 105J | Muffler - Rear | 79 | STD551125 | *Lockwasher 1/4 |
| 13 | 104J | Muffler - Front | 80 | STD541025 | *Hex Nut 1/4 - 20 UNC |
| 14 | 634A901 | Clutch Pedal Weldment | 81 | 5501P | Phillips Pan Hd. Self Tap Screw 10 - 24 x 3/8 Type T |
| 15 | 89J | Link | | | |
| 16 | 92J | Push-On Nut | 82 | STD522515 | *Hex Bolt 1/4 - 20 x 1 - 1/2 Grade 5 |
| 17 | 93J | Rubber Pedal | 83 | 1605H | Locknut 1/4 - 20 UNC |
| 18 | 91J | Pivot Spacer | 84 | STD522507 | *Hex Bolt 1/4 - 20 x 3/4 |
| 19 | 267J | Foot Pedal | 85 | STD523107 | *Hex Bolt 5/16 - 18 x 3/4 |
| 20 | 3366P | Soc. Hd. Cap Screw 5/16 - 18 x 3/4 | 86 | STD551131 | *Lockwasher 5/16 |
| 21 | 8058R | Grill Cable | 87 | 5554P | *Phillips Pan Hd. Self Tap Screw 10 - 16 Hi-Lo Thd. x 1/2 Blunt Point Mounting Clip |
| 22 | 875J | Grill Brace | | | |
| 23 | 634A910 | Engine, Onan 18 H.P. B48M-GAO18/3417A | 88 | 8768H | Decal - Grill |
| 24 | 9396E | Sq. Key 1/4 x 2 | 89 | 1597J | |
| 25 | 8245R | Belt Retainer Finger | 91 | STD551031 | *Washer 11/32 x 11/16 x 16 Ga. |
| 26 | 634A104 | Engine Pulley w/Set Screws | 92 | STD523110 | *Hex Bolt 5/16 - 18 x 1 |
| 27 | 634A527 | Belt Guide Weldment | 93 | STD541031 | *Hex Nut 5/16 - 18 UNC |
| 28 | 8704H1 | Spacer | 94 | 4540P | Hex Forged Socket Hdless. Set Screw 5/16 - 18 x 1/2 |
| 29 | 4939M | Retainer Spring | | | |
| 30 | 9011H | Belt Retainer | 95 | STD523710 | *Hex Bolt 3/8 - 16 x 1 |
| 31 | 634A659 | Belt Guard Weldment | 96 | STD551137 | *Lockwasher 3/8 |
| 32 | 8238H | Split Spacer | 97 | STD541037 | *Hex Nut 3/8 - 16 UNC |
| 33 | 50P | Carriage Bolt 3/8 - 16 x 2 - 1/4 | 98 | STD551037 | *Washer 13/32 x 13/16 x 16 Ga. |
| 34 | 1545P | Washer 17/32 x 1 x 16 Ga. | 99 | 3154P | Slt. Fil. Hd. Machine Screw 1/4 - 20 x 2 - 1/4 |
| 35 | STD561210 | *Cotter Pin 1/8 x 1 | | | |
| 36 | 634A900 | Hood Latch | 100 | 347H | Huglock Nut 1/4 - 20 UNC |
| 37 | 8457R | Support Bumper | 102 | STD533107 | *Carriage Bolt 5/16 - 18 x 3/4 |
| 38 | 634A903 | Battery Support Bracket (Inc. Key 39) | 103 | STD523712 | *Hex Bolt 3/8 - 16 x 1 - 1/4 |
| 39 | 7756R | Bearing | 104 | 5557P | Hex Washer Hd. Thd. Cutting Screw 1/4 - 20 x 1/2 Type 1 |
| 40 | 8006R | Cap | | | |
| 41 | 7729R | Cover - R.H. | 105 | 6106R | Cable Tie |
| 42 | 1599J | Decal - Grill, L.H. | 106 | 3035P | Hex Bolt 7/16 - 14 x 1 - 1/4 |
| 43 | 634A902 | Lever Weldment | 107 | STD551143 | *Lockwasher 7/16 |
| 45 | 634A785 | Hanger Weldment R.H. - Front | 108 | STD523707 | *Hex Bolt 3/8 - 16 x 3/4 |
| 46 | 7944R | Belt Tightener Arm | 109 | 5394H | Locknut 3/8 - 16 UNC |
| 47 | 7948R | Return Spring | 110 | 6055P | Hex Slt. Hd. Machine Screw w/Sems Int. Tooth Lockwasher 10 - 32 x 1/4 Sq. Neck Carriage Bolt 10 - 24 x 1/2 |
| 48 | 7810H | Locknut 3/8 - 24 UNF | | | |
| 49 | 634A814 | Hanger Weldment - Rear | 111 | 53P | Washer 7/32 x 7/16 x 18 Ga. |
| 50 | 634A787 | Drawbar and Weldnuts | 112 | 1535P | |
| 51 | 634A355 | Hanger Weldment - L.H. - Front | 113 | STD551110 | *Lockwasher No. 10 |
| 52 | 7931R | Choke Control | 114 | STD541010 | *Hex Nut 10 - 24 UNC |
| 53 | 1518J | Throttle Control (Inc. Key 61, 62 & 63) | 115 | STD522505 | *Hex Bolt 1/4 - 20 x 1/2 |
| 54 | 97J | Adaptor Bar | 116 | 3022P | Hex Bolt 3/8 - 16 x 7/8 |
| 55 | 1596J | Decal (Shift Pattern) | 117 | STD541137 | *Hex Nut 3/8 - 24 UNF |
| 56 | 634A888 | Chassis Ass'y. (Inc. Key 57 & 58) | 120 | STD523712 | *Hex Bolt 3/8 - 16 x 1 - 1/4 Gr. 5 |
| 57 | 6468H | Bearing | 121 | 1402P | Ext. Tooth Lockwasher - 3/8 |
| 58 | 4766H | Bearing | | | |
| 59 | 634A908 | Engine Mount Ass'y. | | | |
| 60 | 96J | Grill Spacer | | | |
| 61 | 9903R | Throttle Wire & Casing | | | |
| 62 | 8204R | Clamp | | | |
| 63 | 1551J | Throttle Control Lever | | | |
| 64 | 634A893 | Dashboard (Inc. Key No's. 66 and 67) | | | |
| 65 | 106J | Battery Support | | | |
| 66 | 1998R | Clip - Dashboard | | | |
| 67 | 8571R | Clip - Dashboard, Center | | | |

*STANDARD HARDWARE--PURCHASE LOCALLY

OPTIONAL EQUIPMENT

Spark Arrestor Muffler 673A224

REPAIR PARTS

GT 18 TWIN GARDEN TRACTOR--MODEL NO. 917.257111 AND 917.257112

STEERING, AND FINAL DRIVE

| KEY NO. | PART NO. | DESCRIPTION | KEY NO. | PART NO. | DESCRIPTION |
|---------|-----------|--------------------------------|---------|-----------|--------------------------------------------------------|
| 1 | 641J | Steering Wheel Insert | 46 | 61P | Sq. Nk. Sht. Shld. Carr. Bolt 3/8 - 16 x 1 Gr. 5 |
| 2 | STD523710 | *Hex Bolt 3/8 - 16 x 1 | 47 | STD551037 | *Washer 13/32 x 13/16 x 16 Ga. |
| 3 | STD551137 | *Lockwasher 3/8 | 48 | 1519P | Washer 15/32 x 1 x 12 Ga. |
| 4 | 1559P | Washer 7/16 x 1 x 10 Ga. | 49 | 5394H | Locknut 3/8 UNC |
| 5 | 4820R | Steering Wheel | 50 | STD523712 | *Hex Bolt 3/8 - 16 x 1 - 1/4 |
| 6 | 5003P | E-Ring | 51 | 1557P | Washer 13/32 x 13/16 x 11 Ga. |
| 7 | 9007H | Cap | | | |
| 8 | 5949H | Rubber Bushing | | | |
| 9 | 7903R | Foot Rest - L.H. | 53 | STD541037 | *Hex Nut 3/8 - 16 UNC |
| 10 | 8900R | Decal (Attach. Clutch) | 54 | STD523715 | *Hex Bolt 3/8 - 16 x 1 - 1/2 |
| 11 | 7904R | Foot Rest - R.H. | 55 | 3022P | Hex Bolt 3/8 - 16 x 7/8 |
| 12 | 1553P | Washer 5/64 x 1 - 1/4 x 16 Ga. | 56 | STD523107 | *Hex Bolt 5/16 - 18 x 3/4 |
| 13 | 9858M1 | Woodruff Key 3/16 x 5/8 | 57 | STD551131 | *Lockwasher 5/16 |
| 14 | 634A626 | Steering Shaft and Pinion | 58 | STD533707 | *Sq. Neck Carriage Bolt 3/8 - 16 x 3/4 |
| 15 | 7987R | Control Knob | 59 | 1304H | Hub Bolt |
| 16 | 6442H | Shift Rod Bracket | 60 | 3034P | Hex Bolt 7/16 - 14 x 1 |
| 17 | 2511P | Cotter Pin 3/16 x 1 | 61 | STD551143 | *Lockwasher 7/16 |
| 18 | 634A22A | Belt Guide | 62 | STD541043 | *Hex Nut 7/16 - 14 UNC |
| 19 | 6477H | Range Shift Rod | 63 | STD522507 | *Hex Bolt 1/4 - 20 x 3/4 |
| 20 | 9594R | Transmission Bracket | 64 | STD551025 | *Washer 9/32 x 5/8 x 16 Ga. |
| 21 | 8674R | Seat Stop | 65 | STD551125 | *Lockwasher 1/4 |
| 22 | 8054R | Rear Tire 23 x 10.00 - 12 | 66 | STD541025 | *Hex Nut 1/4 - 20 UNC |
| 23 | 795R | Tire Valve | 70 | STD533107 | *Short Shoulder Sq. Neck Carriage Bolt 5/16 - 18 x 3/4 |
| 24 | 469J | Rear Wheel | | | |
| 25 | 9428R | Fender - R.H. | 71 | STD551031 | *Washer 11/32 x 11/16 x 16 Ga. |
| 26 | 634A692 | Wheel Hub - Rear | 72 | 1685H | Lock Nut 5/16 - 18 UNC |
| 27 | 7563R | Axle Thrust Washer | 73 | STD523707 | *Hex Bolt 3/8 - 16 x 3/4 |
| 28 | 5845R | Retaining Ring | 74 | 52P | Carriage Bolt 1/2 - 13 x 1 - 1/4 Gr. 5 |
| 29 | 9427R | Fender - L.H. | 75 | 1578P | Washer 3/4 x 1 - 1/8 x 11 Ga. |
| 30 | 2656R | Bracket - Tail Light | 76 | 1560P | Washer 17/32 x 1 - 1/2 x 11 Ga. |
| 31 | 125J | Seat Stop Bracket | 77 | STD551150 | *Lockwasher 1/2 |
| 32 | 126J | Fuel Tank Retainer | 78 | STD541050 | *Hex Nut 1/2 - 13 UNC |
| 33 | 8141H | Seat Spring Reinforcement | 79 | STD523108 | *Hex Bolt 5/16 - 18 x 7/8 |
| 34 | 7898R | Seat Spring | 80 | 9547R | Rubber Grommet |
| 35 | 634A776 | Seat Plate Weldment | 81 | 1600J | Steering Wheel Decal |
| 36 | 634A532 | Seat Bracket Weldment | 82 | 124J | Rubber Bumper |
| 37 | 7897R | Bracket, Seat Pivot | -- | 53J | Warranty Tag |
| 38 | 1677J | Seat | --- | 2196J | Owners Manual |
| 39 | 1461J | Fuel Gauge | | | |
| 40 | 7885R | Fuel Tank | | | |
| 41 | 6999R | Fuel Line Clamp | | | |
| 42 | 2751R | Clip - Fuel Line | | | |
| 43 | 7834R | Fuel Line (Long) | | | |
| 44 | 266J | In-Line Filter | | | |
| 45 | 7833R | Fuel Line (Short) | | | |
| 45A | 9297R | Clip - Fuel Line | | | |

*STANDARD HARDWARE--PURCHASE LOCALLY

REPAIR PARTS

GT 18 TWIN GARDEN TRACTOR--MODEL NO. 917.257111 AND 917.257112

BRAKE AND CLUTCH

another free manual from www.searstractormanuals.com

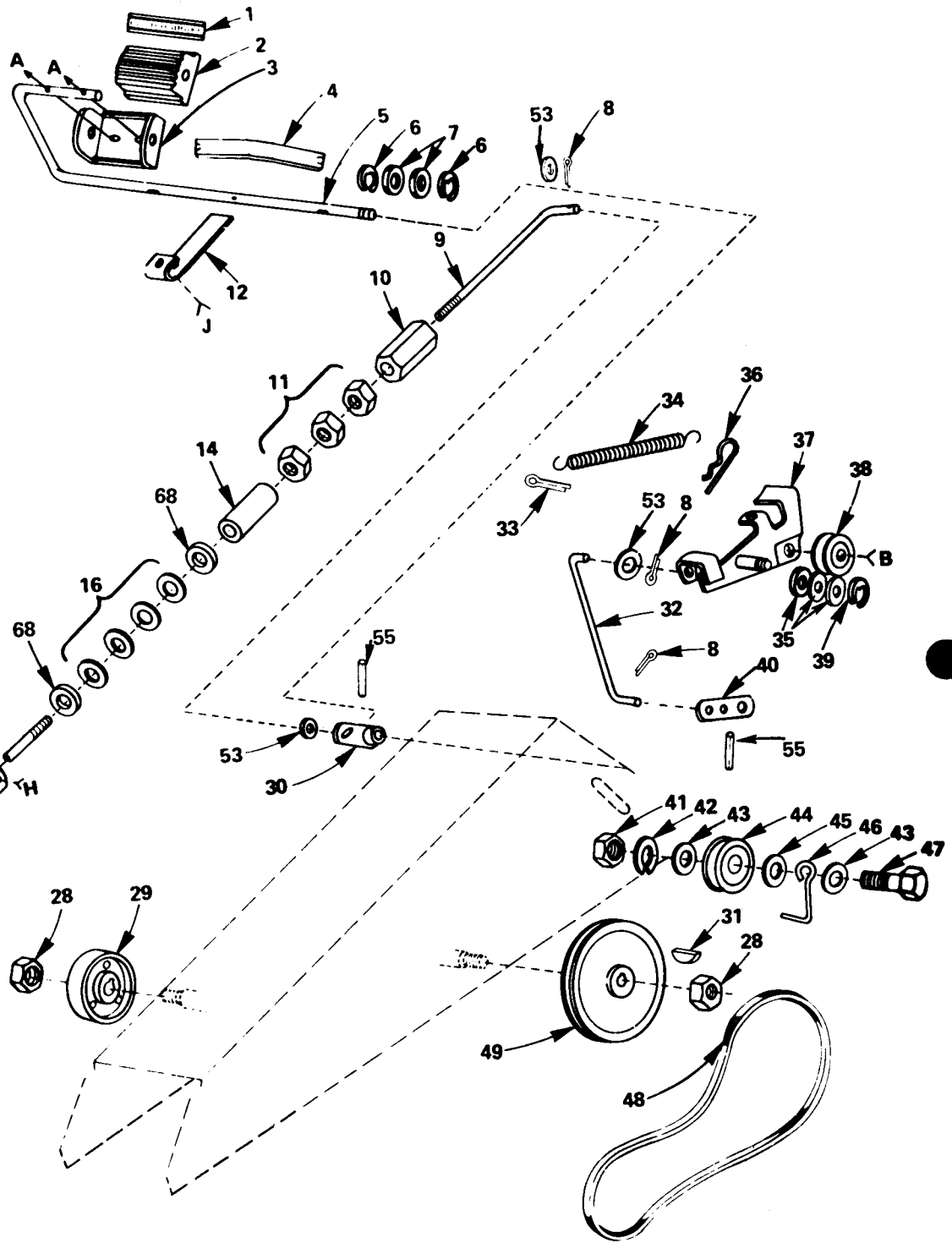

- | | | | | | | | |
|----------|----------|----------|----------|----------|----------|----------|----------|
| A | B | D | E | F | G | H | J |
| | | | | | | | |
| | | | | | | | |
| | | | | | | | |

REPAIR PARTS

GT 18 TWIN GARDEN TRACTOR--MODEL NO. 917.257111 AND 917.257112

BRAKE AND CLUTCH

| KEY NO. | PART NO. | DESCRIPTION | KEY NO. | PART NO. | DESCRIPTION |
|---------|-----------|------------------------------------|---------|-----------|-----------------------------------------------------|
| 1 | 8899R | Insert Clutch-Brake | 37 | 634A754 | Idler Bracket Weldment |
| 2 | 8882R | Foot Pedal | 38 | 6636H | Idler |
| 3 | 8765H | Foot Pedal Bracket | 39 | 5002P | E-Ring |
| 4 | 9008H | Spring | 40 | 634A898 | Steering Arm Assembly |
| 5 | 111J | Foot Pedal Shaft | 41 | STD541043 | *Hex Nut 7/16 - 14 UNC |
| 6 | 5001P | E-Ring | 42 | STD551143 | *Lockwasher 7/16 |
| 7 | 1527P | Washer 21/32 x 7/8 x 16 Ga. | 43 | 1544P | Washer 15/32 x 15/16 x 16 Ga. |
| 8 | 2505P | Cotter Pin 1/8 x 3/4 | 44 | 6635H | Flat Idler |
| 9 | 2202R | Brake Rod - Front | 45 | 1520P | Washer .469 I.D. x 1 - 1/8 x 11 Ga. |
| 10 | 6417H | Turnbuckle | 46 | 6479H1 | Belt Finger |
| 11 | STD541037 | *Hex Nut 3/8 - 16 UNC | 47 | 3262P | Hex Bolt 7/16 - 14 x 2 - 1/2 |
| 12 | 7823R | Safety Start Actuator | 48 | 2692R | V-Belt |
| 14 | 2201R | Bushing | 49 | 6461H2 | Pulley, Transmission |
| 15 | 1557P | Washer 13/32 x 13/16 x 11 Ga. | 50 | STD522507 | *Hex Bolt 1/4 - 20 x 3/4 |
| 16 | 2263R | Spring Washer | 51 | STD551125 | *Lockwasher 1/4 |
| 17 | 9686R | Parking Brake Yoke | 52 | STD623710 | *Fin. Hex Bolt 3/8 - 24 x 1 |
| 18 | 175H | Roll Pin | 53 | STD551037 | *Washer 13/32 x 13/16 x 16 Ga. |
| 19 | 634A887 | Lock Bracket Assembly | 54 | STD541337 | *Hex Jam Nut 3/8 - 24 UNF |
| 20 | 2221R | Parking Brake Spacer | 55 | 5142H | Roll Pin |
| 21 | 5999H | Spring Washer | 56 | 3022P | Hex Bolt 3/8 - 16 x 7/8 |
| 22 | 4379H | Handle Grip | 57 | STD551137 | *Lockwasher 3/8 |
| 23 | 626A341 | Parking Lock Handle Assembly | 58 | 3164P | Flat Hd. Machine Screw - Undercut 3/8 - 16 x 3/4 |
| 24 | 7810H | Gripco Centerlock Nut 3/8 - 24 UNF | 59 | 11P | Sq. Neck Carriage Bolt 1/4 - 20 x 5/8 |
| 25 | 626A365 | Brake Rod Assembly | 60 | STD541025 | *Hex Nut 1/4 - 20 UNC |
| 26 | 673A211 | Brake Band and Lining | 61 | STD523108 | *Hex Bolt 5/16 - 18 x 7/8 |
| 27 | 634A168 | Brake Bracket Assembly | 62 | 1685H | Locknut 5/16 - 18 UNC |
| 28 | 9204H | Lock Nut 1/2 - 20 UNF | 63 | 3244P | Hex Bolt 1/4 - 28 x 5/8 Gr. 5 |
| 29 | 214J | Brake Drum | 64 | 9071H | Huglock Nut 1/4 - 28 UNF |
| 30 | 634A899 | Brake Arm Assembly | 65 | 3326P | Hex Hd. Mach. Screw 6 - 32 x 1 |
| 31 | 9858M1 | Woodruff Key | 66 | 1567P | Washer 5/32 x 3/8 x 20 Ga. |
| 32 | 9288R | Clutch Rod | 67 | 562P | Centerlock Nut 6 - 32 UNC |
| 33 | 2514P | Cotter Pin 1/4 x 1 | 68 | 1602P | Washer 13/32 x 5/8 x 11 Ga. |
| 34 | 6486H | Spring | | | |
| 35 | STD551050 | *Washer 17/32 x 1 - 1/16 x 21 Ga. | | | |
| 36 | 4939M | Retainer Spring | | | |
| 36A | 544J | Hose Shield | | | |

*STANDARD HARDWARE--PURCHASE LOCALLY

another free manual from www.searctractormanuals.com

SCHEMATIC DIAGRAM

another free manual from www.searstractormanuals.com

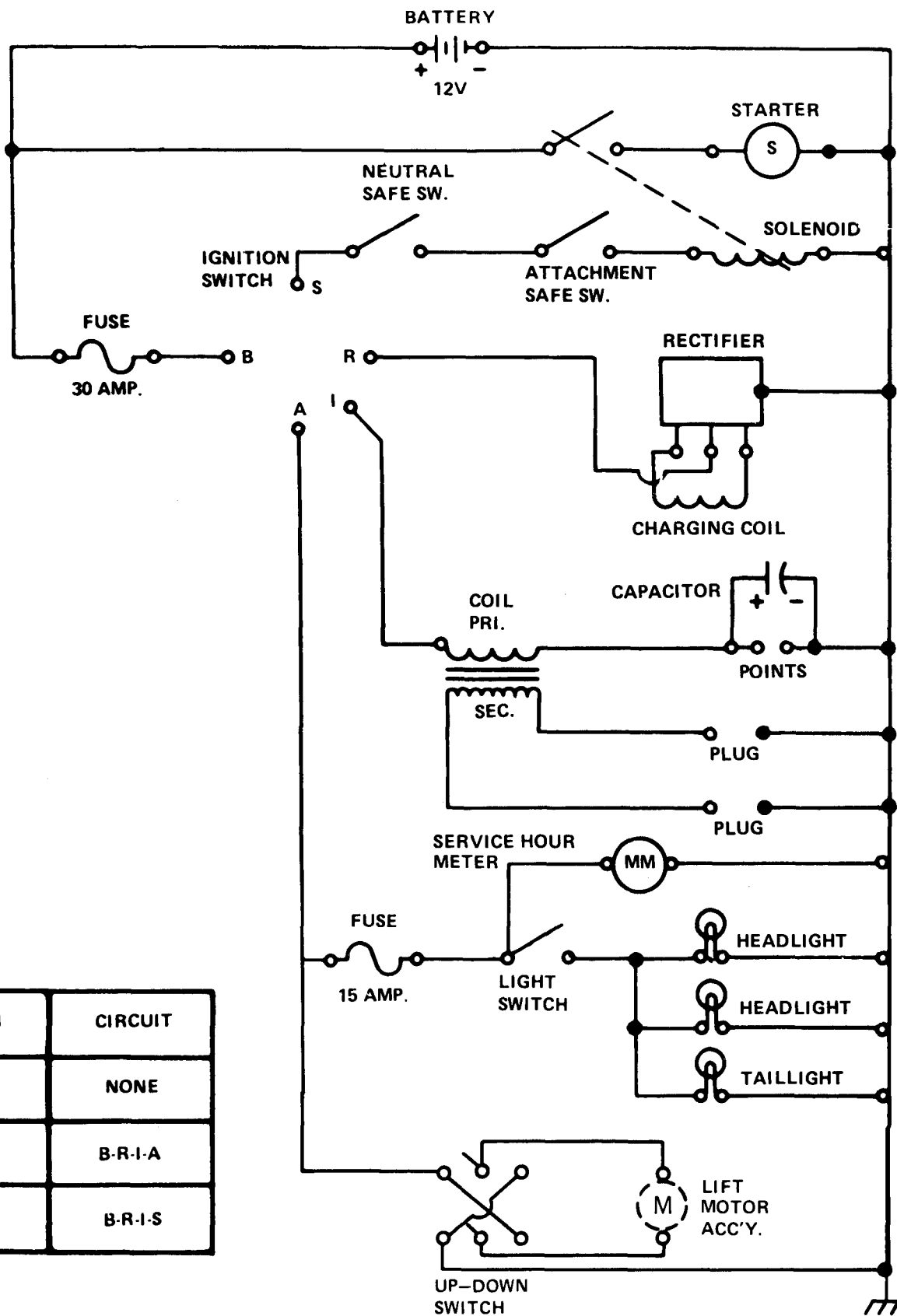

| POSITION | CIRCUIT |
|----------|---------|
| OFF | NONE |
| RUN | B-R-I-A |
| START | B-R-I-S |

NOTE: IF WIRING INSULATED CLIPS AND CABLE TIES WERE REMOVED FOR SERVICING OF UNIT, THEY SHOULD BE REPLACED TO PROPERLY SECURE YOUR WIRING.

CHASSIS GROUND

REPAIR PARTS

GT 18 TWIN GARDEN TRACTOR--MODEL NO. 917.257111 AND 917.257112

ELECTRICAL

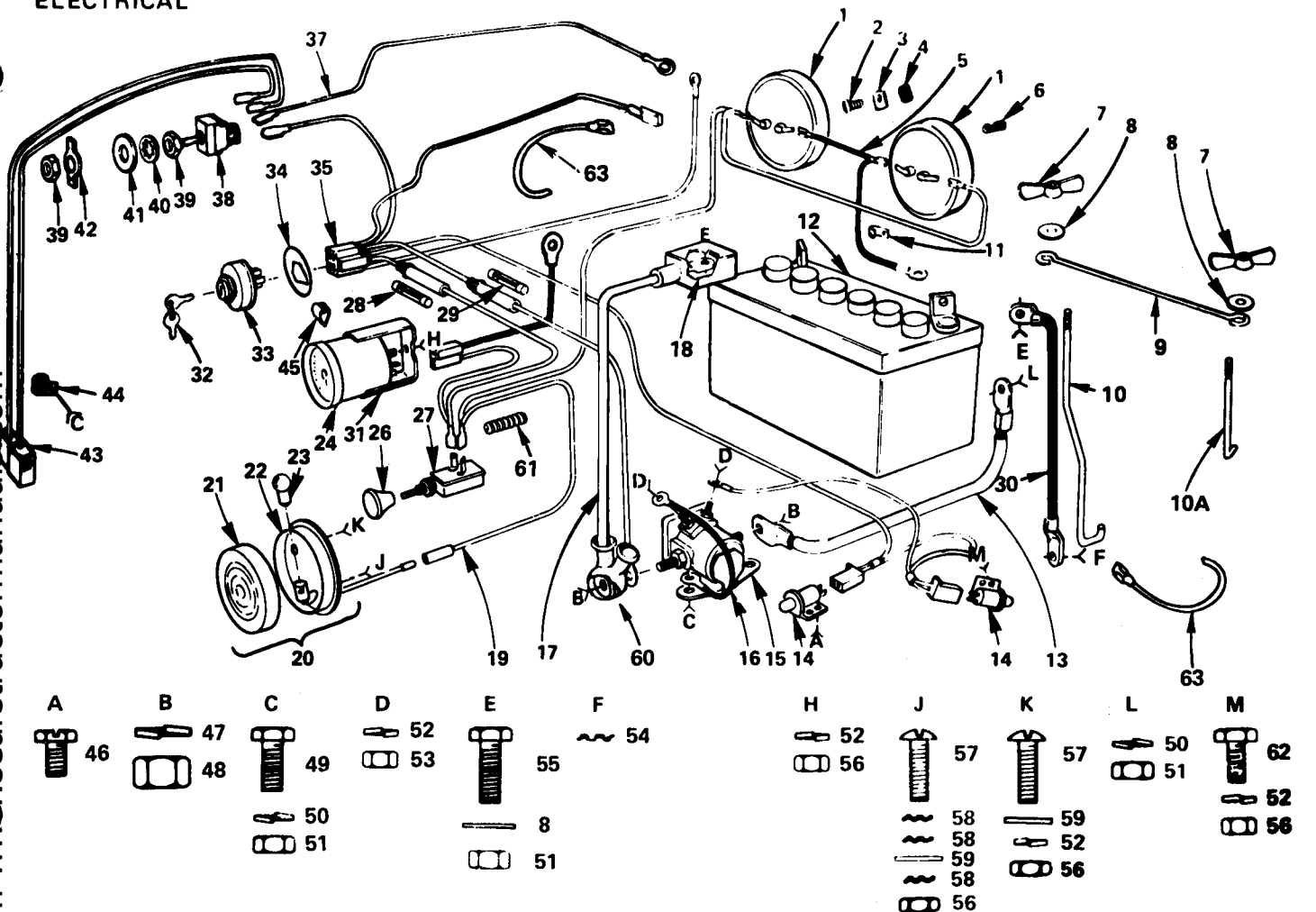

| KEY NO. | PART NO. | DESCRIPTION | KEY NO. | PART NO. | DESCRIPTION |
|---------|----------|----------------------------------------------------------|---------|-----------|-------------------------------------------------------------------------|
| 1 | 6452R | Headlight | 33 | 2683R | Ignition Switch |
| 2 | 5554P | Phillips Pan Hd. Thd. Cutting Screw No. 10 - 16 x 1/2 | 34 | 8656R | Terminal Identifier |
| 3 | 8768H | Mounting Clip | 35 | 9565R | Wire Harness - Main |
| 4 | 8784H1 | Rubber Spacer | 37 | 9698R | Wire, Ground Lift Switch |
| 5 | 8031R | Headlight Ground Wire | 38 | 8984R | Switch, Elec. Lift |
| 6 | 9197H | Hose | 39 | 566P | Hex Nut, Steel 7/16 - 32 NS - 2A |
| 7 | 3748M | Wing Nut 1/4 - 20 UNC | 40 | 7319R | Lockwasher, Internal Tooth |
| 8 | 1506P | Washer 9/32 x 5/8 x 16 Ga. | 41 | 1518P | Washer 15/32 x 11/16 x 16 Ga. |
| 9 | 7955R | Battery Clamp | 42 | 9349R | Switch Plate |
| 10 | 2685R | Battery Bolt | 43 | 8985R | Lift Motor Harness |
| 10A | 88J | Battery Bolt | 44 | 5320R | Clip, Wire |
| 11 | 4171R | Insulated Clip | 45 | 8615R | Clip |
| 12 | 8859R | Battery - "Sears Die-Hard" | 46 | 5534P | Slotted Hex Indented Hd. Self Tapping Screw No. 10 - 24 x 3/8 Type 1 |
| 13 | 2235R | Cable - Solenoid to Starter | 47 | STD551131 | * Lockwasher 5/16 |
| 14 | 7755R | Safety Switch | 48 | STD541331 | * Hex Jam Nut 5/16 - 24 UNF |
| 15 | 7754R | Solenoid | 49 | STD522506 | * Hex Bolt 1/4 - 20 x 5/8 |
| 16 | 8027R | Wire - Ground to Solenoid | 50 | STD551125 | * Lockwasher 1/4 |
| 17 | 116J | Battery Cable | 51 | STD541025 | * Hex Nut 1/4 - 20 UNC |
| 18 | 225J | Terminal Cover | 52 | STD551110 | * Lockwasher No. 10 |
| 19 | 8030R | Light Harness | 53 | STD541110 | * Hex Nut No. 10 - 32 UNF |
| 20 | 8089H | Taillight (Inc. Key No's. 21, 22, & 23) | 54 | 1402P | Ext. Tooth Lockwasher 3/8 |
| 21 | 8292H | Lens - Taillight | 55 | STD522507 | * Hex Bolt 1/4 - 20 x 3/4 |
| 22 | 8293H | Housing - Taillight | 56 | STD541010 | * Hex Nut No. 10 - 24 UNC |
| 23 | 8291H | Bulb No. 1895 2 Candle Power | 57 | STD511007 | * Slt'd. Truss Hd. Mach. Screw 10 - 24 x 3/4 |
| 24 | 7763R | Maintenance Meter | 58 | 1404P | Ext. Tooth Lockwasher No. 10 |
| 26 | 7794R | Light Switch Knob | 59 | STD551010 | * Washer 7/32 x 1/2 x 18 Ga. |
| 27 | 7793R | Light Switch | 60 | 51J | Solenoid Terminal Cover |
| 28 | 2212R | Fuse - 15 Amp. | 61 | 302J | Wire Guard |
| 29 | 6347R | Fuse - 30 Amp. | 62 | 3218P | Hex Hd. Mach. Screw No. 10 - 24 x 1/2 |
| 30 | 2753R | Battery Cable - Ground | 63 | 6106R | Cable Tie |
| 31 | 8066R | Maintenance Meter Bracket | | | |
| 32 | 7552H | Key Set | | | |

*STANDARD HARDWARE--PURCHASE LOCALLY

REPAIR PARTS

GT 18 GARDEN TRACTOR--MODEL NO. 917.257111 ONLY

TRANSAXLE

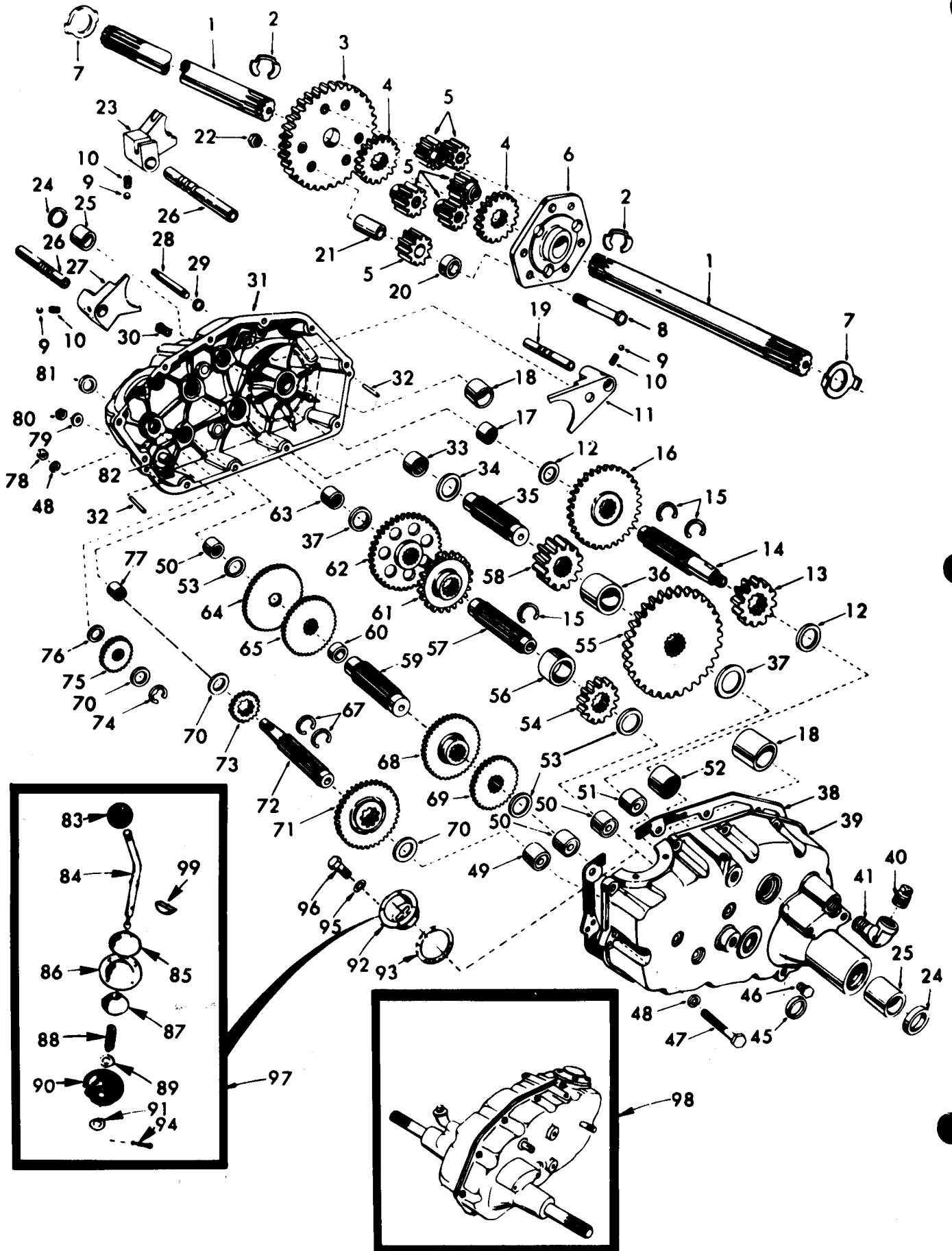

another free manual from www.searctractormanuals.com

REPAIR PARTS

GT 18 TWIN GARDEN TRACTOR--MODEL NO. 917.257111 ONLY

TRANSAXLE

| KEY NO. | PART NO. | DESCRIPTION | KEY NO. | PART NO. | DESCRIPTION |
|---------|-----------|----------------------------------------------------------------------------------------------------------------|---------|-----------|-----------------------------------------------------|
| 1 | 4197R | Axle Shaft | 49 | 4895H | Needle Bearing |
| 2 | 5845R | Retaining Ring | 50 | 4222R | Needle Bearing |
| 3 | 4199R | Final Drive Gear | 51 | 1529R | Needle Bearing |
| 4 | 4216R | Differential Gear | 52 | 8119M | Needle Bearing |
| 5 | 4215R | Differential Pinion | 53 | 4220R | Thrust Bearing Race |
| 6 | 4217R | Differential Carrier | 54 | 4209R | 3rd Reduction Pinion - Low |
| 7 | 6256H | Axle Thrust Washer | 55 | 4213R | 4th Reduction Gear |
| 8 | 3056P | Hex Bolt 3/8 - 24 UNF x 3 - 1/4 (1" Thread Length) | 56 | 4442R | 3rd Reduction Pinion Spacer |
| 9 | 7392M | Steel Ball | 57 | 4195R | 2nd Reduction Gear Shaft |
| 10 | 6272H | Spring Shift Fork Detent | 58 | 4214R | Final Drive Pinion |
| 11 | 4985R | Shift Fork, High - Low Range | 59 | 4194R | 1st Reduction Gear Shaft |
| 12 | 6266H | Thrust Bearing Race | 60 | 7528R | 1st Reduction Shaft Spacer |
| 13 | 4212R | 4th Reduction Pinion | 61 | 4208R | 3rd Reduction Pinion - High |
| 14 | 4196R | 3rd Reduction Gear Shaft | 62 | 4207R | 2nd Reduction Gear |
| 15 | 6276H | Snap Ring - Crescent Type | 63 | 7398H | Needle Bearing |
| 16 | 633A63 | High - Low Range Gears | 64 | 4203R | Low Speed Gear and 2nd Reduction Pinion Cluster |
| 17 | 8118M | Needle Bearing | 65 | 4204R | Reverse Gear |
| 18 | 8740H1 | Sintered Iron Bearing | | | |
| 19 | 6217H | Shift Fork Shaft, High - Low Range | 67 | 4926H | Snap Ring - Crescent Type |
| 20 | 4218R | Differential Pinion Spacer | 68 | 4205R | Intermediate Speed Gear |
| 21 | 6252H1 | Differential Pinion Bushing | 69 | 4206R | High Speed Gear |
| 22 | 7810H | Gripco Centerlock Nut 3/8 - 24 UNF | 70 | 1370H | Thrust Bearing Race |
| 23 | 4986R | Shift Fork - L.H. | 71 | 633A69 | Intermediate and High Speed Cluster Pinions |
| 24 | 7393R | Oil Seal | | | |
| 25 | 992R1 | Sintered Iron Bearing | 72 | 4193R | Input Shaft |
| 26 | 6216H | Shift Fork Shaft | 73 | 4201R | Low Speed Pinion |
| 27 | 6262H | Shift Fork - R.H. | 74 | 5001P | E-Ring |
| 28 | 6215H | Shift Shaft, High - Low Range | 75 | 1153R | Reverse Idler Gear |
| 29 | 6269H | Oil Seal | 76 | 7392H | Reverse Idler Thrust Washer |
| 30 | 5855H | Pressure Relief Valve | 77 | 5529H | Needle Bearing |
| 31 | 633A65 | Gearcase, Reverse Idler Shaft and Bearings - R.H. (Inc. Key No's. 17, 18, 25, 33, 50, 63, 76, 77 and 82) | 78 | STD541031 | *Hex Nut 5/16 - 18 UNC |
| | | | 79 | 1167R | Sealing Washer |
| 32 | 6277H | Dowel Pin | 80 | 541P | Hex Jam Nut 7/16 - 20 UNF |
| 33 | 4225R | Needle Bearing | 81 | 6270H | Oil Seal |
| 34 | 7396H | Thrust Bearing Race | 82 | 7384H | Reverse Idler Shaft |
| 35 | 4198R | 4th Reduction Gear Shaft | 83 | 7987R | Control Knob |
| 36 | 4200R | 4th Reduction Gear Spacer | 84 | 8551R | Gear Shift Lever - Bent |
| 37 | 7395H | Thrust Bearing Race | 85 | 9013R | Gear Shift Cap |
| 38 | 6275H | Gearcase Gasket | 86 | 633A85 | Gear Shift Ball Cover and Pin |
| 39 | 633A64 | Gearcase and Bearings - L.H. (Inc. Key No's. 18, 25, 49, 50 (2), 51 and 52) | 87 | 8739H1 | Shift Lever Guide Ball - Keyed Spring |
| | | | 88 | 4924H | |
| 40 | 4002P | Pipe Plug 1/2 - 14 N.P.T. | 89 | STD551043 | Washer 15/32 x 59/64 x 16 Ga. |
| 41 | 4003P | Street Elbow 90°, 1/2 - 1/4 N.P.T. | 90 | 8105R | Shift Mechanism Seal |
| 45 | 6271H | Oil Seal | 91 | 1569P | Washer 9/16 x 15/16 x 11 Ga. |
| 46 | 4001P | Pipe Plug 1/4 - 18 N.P.T. | 92 | 75J | Gear Shift Gate |
| 47 | STD523115 | *Hex Bolt 5/16 - 18 x 1 - 1/2 Grade 5 | 93 | 6274H | Shift Ball Cover Gasket |
| | | | 94 | 2505P | Cotter 1/8 x 3/4 |
| 48 | 1007P | Lockwasher 5/16 Extra Heavy | 95 | STD551131 | Lockwasher 5/16 |
| | | | 96 | 3159P | Hex Bolt 5/16 - 18 UNC x 7/8 |
| | | | 97 | 633A82 | Gear Shift Lever Ass'y. |
| | | | 98 | 633A78 | Transaxle Assembly Less Brake Drum & Shift Lever |
| | | | 99 | 7835M | Woodruff Key 1/8 x 1/2 |

*STANDARD HARDWARE--PURCHASE LOCALLY

REPAIR PARTS

GT 18 GARDEN TRACTOR--MODEL NO. 917.257112 ONLY

TRANSAXLE

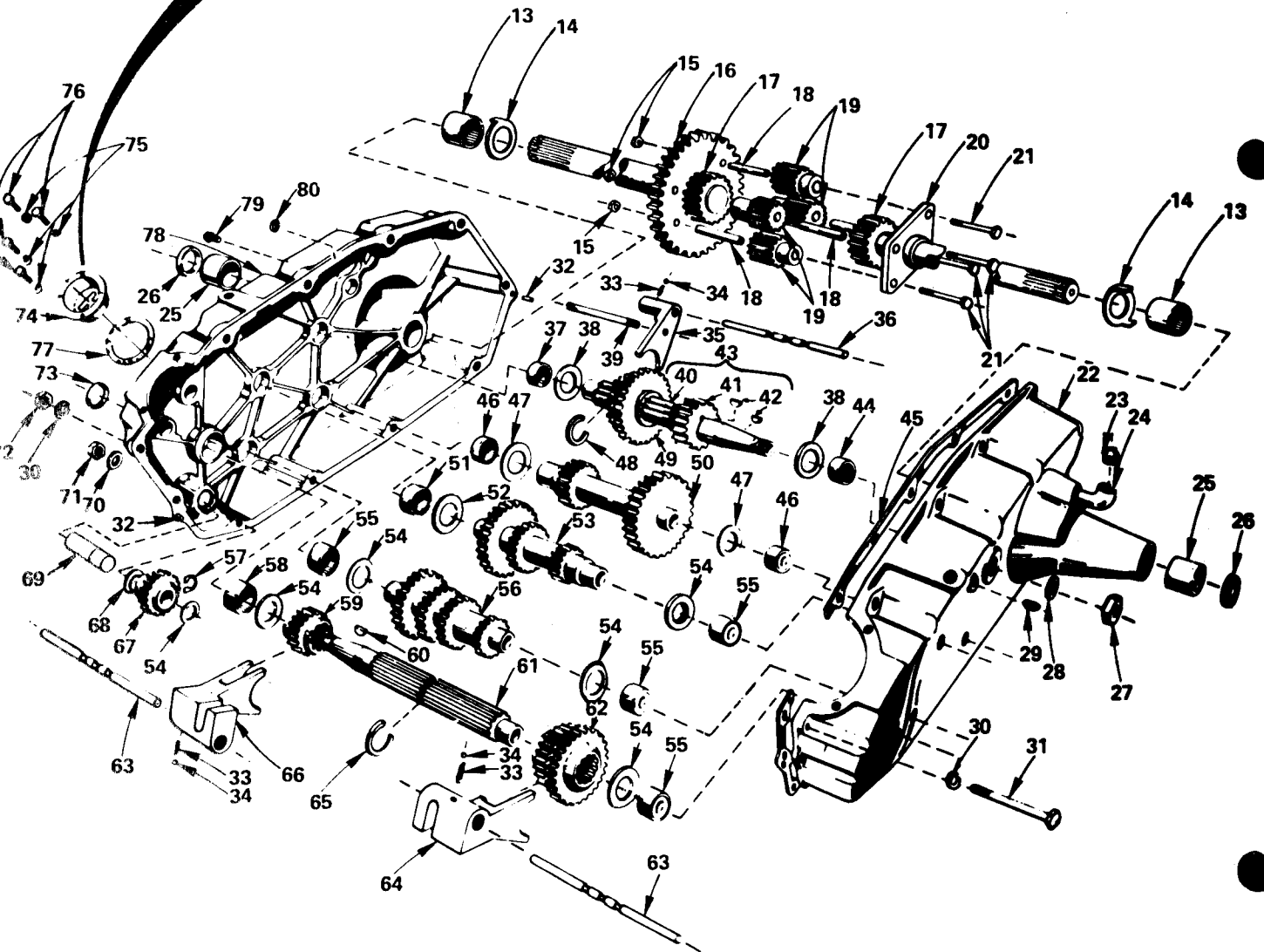
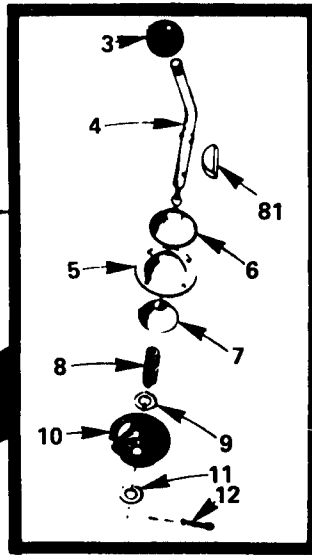
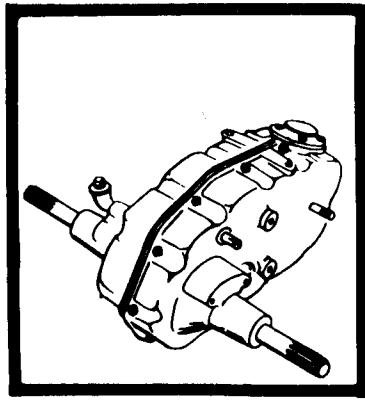

REPAIR PARTS

GT 18 GARDEN TRACTOR--MODEL NO. 917.257112 ONLY

TRANSAXLE

| KEY NO. | PART NO. | DESCRIPTION | KEY NO. | PART NO. | DESCRIPTION |
|---------|-----------|-------------------------------------------------------------------------------|---------|-----------|--------------------------------------------------|
| 1 | 633A92 | Transaxle Assembly Less Brake Drumn & Shift Lever (Inc. Key No's. 13 thru 80) | 44 | 8119M | Needle Bearing |
| 2 | 633A82 | Gear Shift Lever Assembly (Inc. Key No's. 3 thru 12 and 81) | 45 | 6275H | Gasket - Gearcase |
| 3 | 7987R | Control Knob | 46 | 8117M | Needle Bearing |
| 4 | 9635R | Gear Shift Lever | 47 | 7396H | Thrust Bearing Race |
| 5 | 633A85 | Gear Shift Ball Cover and Pin | 48 | 6276H | Snap Ring - Crescent Type |
| 6 | 9013R | Gear Shift Cap | 49 | 633A14 | High - Low Range Gears and Hub |
| 7 | 8739H1 | Shift Lever Guide Ball | 50 | 633A33 | 4th Reduction Shaft and Gears |
| 8 | 4924H | Spring | 51 | 7398H | Needle Bearing |
| 9 | STD551043 | *Washer 15/32 x 59/64 x 16 Ga. | 52 | 7395H | Thrust Bearing Race |
| 10 | 8105R | Shift Mechanism Seal | 53 | 633A31 | 2nd Reduction Shaft and Gears |
| 11 | 1525P | Washer 9/16 x 15/16 x 11 Ga. | 54 | 1370H | Thrust Bearing Race |
| 12 | 2505P | Cotter 1/8 x 3/4 | 55 | 4895H | Needle Bearing |
| 13 | 3039R | Needle Bearing | 56 | 633A30 | Speed Change Gears and Shaft |
| 14 | 6256H | Axle Thrust Washer | 57 | 5001P | E-Ring |
| 15 | 7810H | Centerlock Gripco Nut 3/8 - 24 UNF | 58 | 4894H | Needle Bearing |
| 16 | 8662H | Final Drive Gear | 59 | 6231H | Low Speed Pinion |
| 17 | 633A73 | Axle Shaft and Gear | 60 | 9858M1 | Woodruff Key |
| 18 | 6252H1 | Bushing - Differential Pinion | 61 | 6218H | Input Shaft |
| 19 | 8657H | Differential Pinion | 62 | 633A11 | Intermediate and High Speed Pinions |
| 20 | 6263H1 | Differential Carrier | 63 | 6216H | Shift Fork Shaft |
| 21 | 3056P | Hex Bolt 3/8 - 24 x 3 - 1/4 1" Thread Length | 64 | 4219R | Shift Fork - L.H. |
| 22 | 633A89 | Gear Case and Bearings - L.H. | 65 | 4926H | Snap Ring - Crescent Type |
| 23 | 4002P | Pipe Plug 1/2 - 14 N.P.T. | 66 | 6262H | Shift Fork - R.H. |
| 24 | 4003P | 90 Street Elbow 1/2 - 14 N.P.T. | 67 | 1153R | Reverse Idler Gear |
| 25 | 992R1 | Sintered Iron Bearing | 68 | 7392H | Reverse Idler Thrust Washer |
| 26 | 7393R | Oil Seal | 69 | 7384H | Reverse Idler Shaft |
| 27 | 9204H | Lock Nut | 70 | 1167R | Sealing Washer |
| 28 | 6271H | Oil Seal | 71 | 541P | Hex Jam Nut 7/16 - 20 UNF |
| 29 | 4001P | Pipe Plug 1/4 - 18 N.P.T. | 72 | STD541031 | *Hex Nut 5/16 - 18 UNC |
| 30 | 1007P | Lockwasher 5/16 Extra Heavy | 73 | 6270H | Oil Seal |
| 31 | STD523115 | *Hex Bolt 5/16 - 18 x 1 - 1/2 Gr. 5 | 74 | 75J | Gear Shift Gate |
| 32 | 6277H | Dowel Pin | 75 | STD551131 | *Lockwasher 5/16 |
| 33 | 6272H | Spring - Shift Fork Detent | 76 | STD523108 | *Hex Bolt 5/16 - 18 x 7/8 |
| 34 | 7392M | Steel Ball | 77 | 6274H | Gasket - Shift Ball Cover |
| 35 | 6260H | Shift Fork High - Low Range | 78 | 633A90 | Gear Case, Reverse Idler Shaft and Bearings R.H. |
| 36 | 6217H | High - Low Range Shift Fork Shaft | 79 | 5855H | Pressure Relief Valve |
| 37 | 8118M | Needle Bearing | 80 | 6269H | Oil Seal |
| 38 | 6266H | Thrust Bearing Race | 81 | 7835M | Woodruff Key |
| 39 | 6215H | High - Low Range Shift Shaft | | | |
| 40 | 6221H | 3rd Reduction Gear Shaft | | | |
| 41 | 8659H | 4th Reduction Pinion | | | |
| 42 | 2228M | Woodruff Key | | | |
| 43 | 633A32 | 3rd Reduction Shaft and Gear (Inc. Key No's. 40, 41 & 42) | | | |

*STANDARD HARDWARE--PURCHASE LOCALLY

REPAIR PARTS

GT 18 TWIN GARDEN TRACTOR--MODEL NO. 917.257111 AND 917.257112

FRONT AXLE

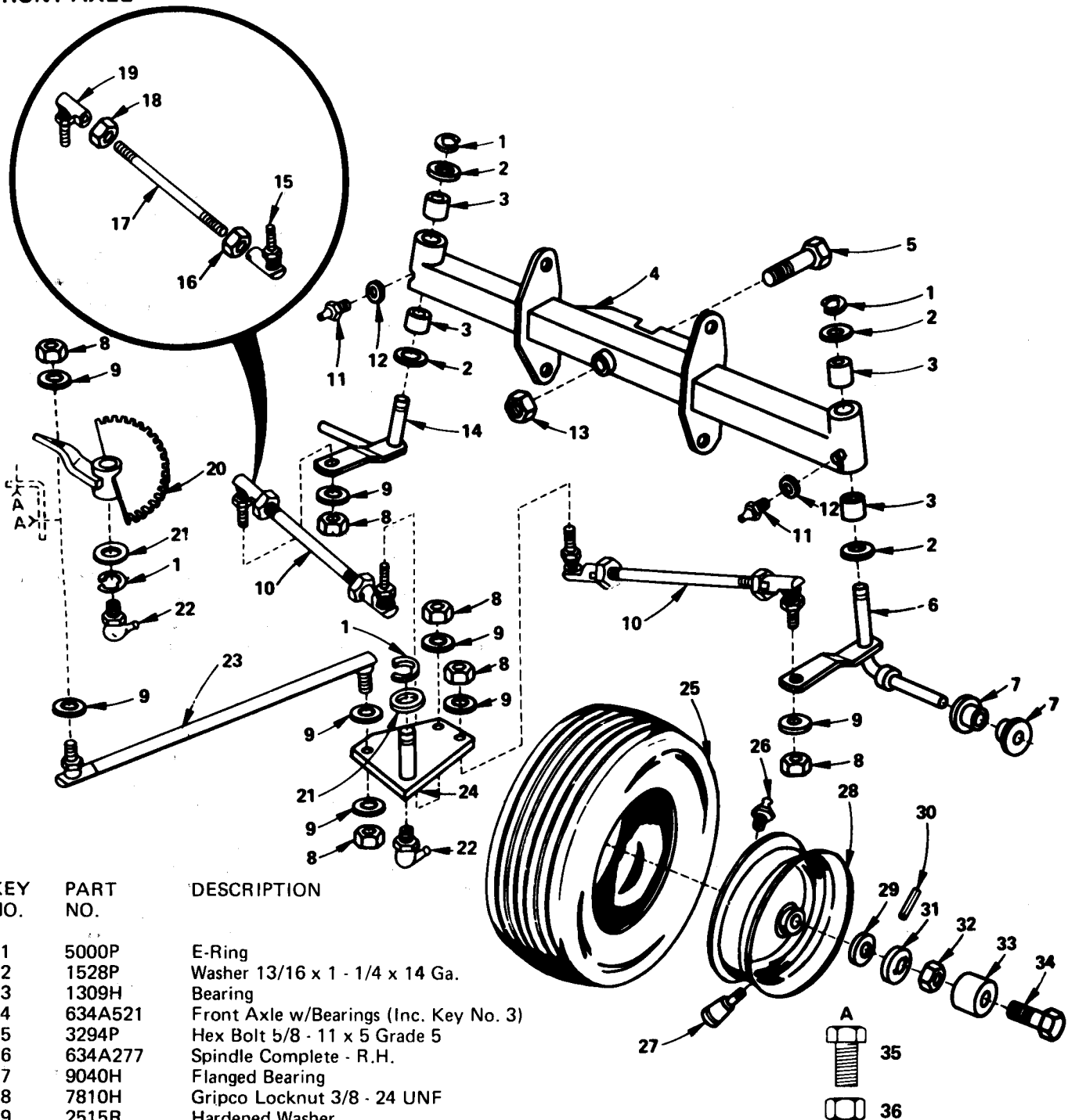

| KEY NO. | PART NO. | DESCRIPTION |
|---------|-----------|---------------------------------------------------------|
| 1 | 5000P | E-Ring |
| 2 | 1528P | Washer 13/16 x 1 - 1/4 x 14 Ga. |
| 3 | 1309H | Bearing |
| 4 | 634A521 | Front Axle w/Bearings (Inc. Key No. 3) |
| 5 | 3294P | Hex Bolt 5/8 - 11 x 5 Grade 5 |
| 6 | 634A277 | Spindle Complete - R.H. |
| 7 | 9040H | Flanged Bearing |
| 8 | 7810H | Gripco Locknut 3/8 - 24 UNF |
| 9 | 2515R | Hardened Washer |
| 10 | 7838R | Tie Rod and Joints (Inc. Key No's. 15, 16, 17, 18 & 19) |
| 11 | 6855M | Grease Fitting |
| 12 | 1505P | Washer 9/32 x 1/2 x 14 Ga. |
| 13 | 4764H | Huglock Nut 5/8 x 11 UNC |
| 14 | 634A278 | Spindle Complete - L.H. |
| 15 | 8515R | Tie Rod Joint (R.H. Thread) |
| 16 | STD541350 | *Hex Jam Nut 1/2 - 20 (R.H. Thread) |
| 17 | 634A819 | Tie Rod and Nuts (Inc. Key No's. 16 & 18) |
| 18 | 559P | Hex Jam Nut 1/2 - 20 (L.H. Thread) |
| 19 | 8514R | Tie Rod Joint (L.H. Thread) |
| 20 | 634A813 | Steering Gear Sector and Arm |
| 21 | 1552P | Washer 49/64 x 1 - 1/4 x 16 Ga. |
| 22 | 6842M | Grease Fitting |
| 23 | 7837R | Drag Link and Joints |
| 24 | 634A98 | Steering Bell Crank Weldment |
| 25 | 2169R | Front Tire - Tubeless 16 x 6.50 - 8 |

| KEY NO. | PART NO. | DESCRIPTION |
|---------|-----------|-------------------------------------|
| 26 | 6856M | Grease Fitting 1/4 - 28 Taper Thrd. |
| 27 | 795R | Tire Valve |
| 28 | 467J | Front Wheel and Bearings |
| 29 | 1562P | Washer 25/32 x 1 - 1/2 x 16 Ga. |
| 30 | 8798H | Roll Pin 5/32 x 1 |
| 31 | 8785H | Wear Washer |
| 32 | 4831H | Elastic Nut 3/4 - 16 UNF |
| 33 | 8763H | Dust Cap - Outer |
| 34 | 3008P | *Hex Bolt 5/16 - 18 x 1/2 |
| 35 | STD623710 | *Hex Bolt 3/8 - 24 x 1 |
| 36 | STD541337 | *Hex Jam 3/8 - 24 UNF |

*STANDARD HARDWARE--PURCHASE LOCALLY

another free manual from www.seartractormanuals.com

REPAIR PARTS

GT 18 TWIN GARDEN TRACTOR--MODEL NO. 917.257111 AND 917.257112
ONAN ENGINE--MODEL NO. B48M-GA018/3417A

FUEL SYSTEM GROUP

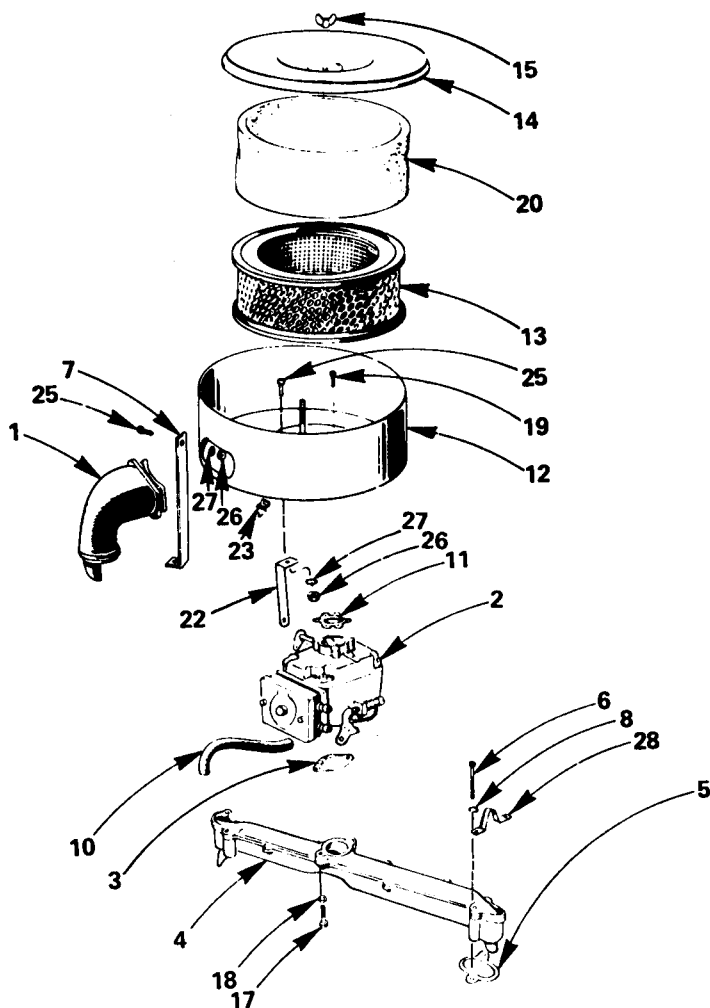

| KEY NO. | PART NO. | DESCRIPTION | KEY NO. | PART NO. | DESCRIPTION |
|---------|----------|--------------------------------------------------|---------|----------|--------------------------------------------------------|
| 1 | 140-1169 | Tube, Air Intake (Air Cleaner to Blower Housing) | 15 | 865-0020 | Nut, Wing - Air Cleaner (1/4 - 20) |
| 2 | 142-0568 | †Carburetor, Gasoline (with Integral Fuel Pump) | 17 | 800-0023 | Screw, Hex Head Cap (1/4 - 20 x 1 - 3/8") |
| 3 | 145-0438 | *Gasket, Carburetor Mounting | 18 | 850-0040 | Washer, Spring Lock (1/4") |
| 4 | 154-1468 | Manifold, Intake | 19 | 815-0463 | Screw, Round Head with Nylon Seal (No. 10 - 32 x 5/8") |
| 5 | 154-1744 | *Gasket, Intake - Manifold | 20 | 140-1259 | Wrapper, Air Cleaner Element |
| 6 | 800-0033 | Screw, Hex Head Cap 5/16 - 18 x 2 | 22 | 140-1313 | Bracket, Air Cleaner Support |
| | 800-0034 | Screw, Hex Head Cap 5/16 - 18 x 2 - 1/4 | 23 | 518-0328 | Clip, Bracket, Cable |
| 7 | 140-1198 | Support, Air Cleaner | 25 | 800-0003 | Screw, Hex Head Cap (1/4 - 20 x 1/2") |
| 8 | 850-0045 | Washer, Spring Lock (5/16") | 26 | 862-0001 | Nut, Hex - Steel (1/4 - 20) |
| 10 | 503-0740 | Hose, Fuel Pump Vacuum | 27 | 853-0013 | Washer, Lock - ET (1/4") |
| 11 | 140-1215 | *Gasket, Air Cleaner Mtg. | 28 | 403-1021 | Bracket, Lifting |
| 12 | 140-1213 | Housing, Air Cleaner | | | |
| 13 | 140-1216 | Element, Air Cleaner | | | |
| 14 | 140-1168 | Cover, Air Cleaner | | | |

† - See separate group for components.

* - Included in Gasket Kit, page 29.

REPAIR PARTS

GT 18 TWIN GARDEN TRACTOR--MODEL NO. 917.257111 AND 917.257112
ONAN ENGINE--MODEL NO. B48M-GA018/3417A

GOVERNOR, STARTER, CHARGING ALTERNATOR AND BLOWER HOUSING GROUP

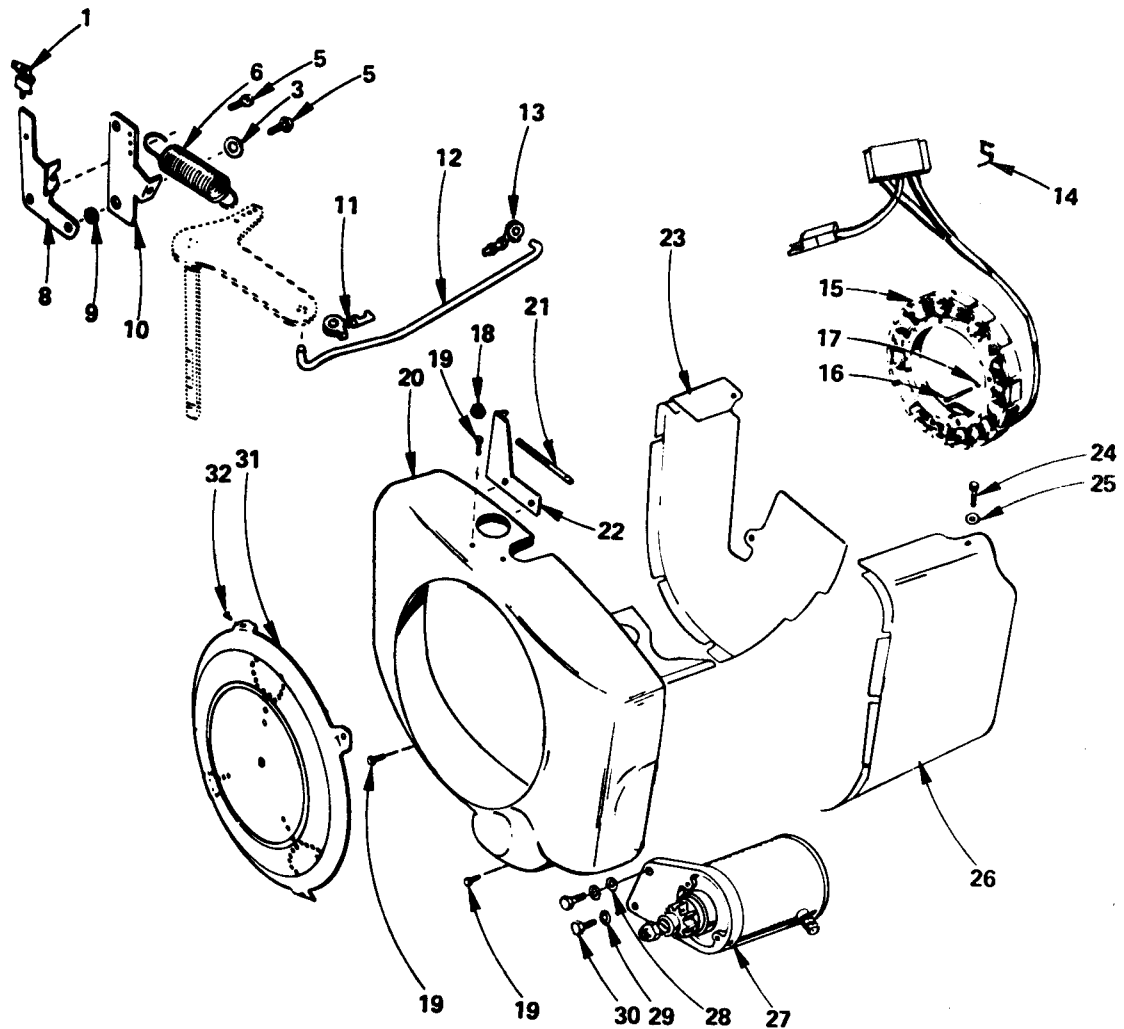

| KEY NO. | PART NO. | DESCRIPTION | KEY NO. | PART NO. | DESCRIPTION |
|---------|----------|--------------------------------------------------|---------|----------|--------------------------------------------------------------|
| 1 | 518-0176 | Clip, Throttle Cable | 19 | 815-0261 | Screw, Hex Head Cap (1/4 - 20 x 7/16") |
| 3 | 526-0214 | Flat Washer 17/64 I.D. x 1/2 x 1/16 | 20 | 134-3401 | Housing, Blower |
| 5 | 815-0436 | Screw, Hex Cap - Flange Locking (1/4 - 20 x 1/2) | 21 | 150-1418 | Stud, Governor |
| 6 | 150-1214 | Spring, Governor | 22 | 150-1433 | Bracket, Governor Control |
| 8 | 150-1343 | Bracket, Governor Mounting | 23 | 134-2989 | Housing, Cylinder Ari - Left |
| 9 | 150-1269 | Bushing Governor Control | 24 | 815-0290 | Screw, Hex Head Cap (1/4 - 20 x 5/8") |
| 10 | 150-1576 | Arm, Governor Control | 25 | 526-0021 | Washer, Flat - Steel (17/64" I.D. x 3/4" O.D. x 1/16" Thick) |
| 11 | 870-0278 | Clip, Governor Control Rod to Governor Arm | 26 | 134-3400 | Housing, Cylinder Air - Right |
| 12 | 150-1350 | Rod, Governor Control | 27 | 191-0933 | Starter, 12 Volt (For Components see separate group) |
| 13 | 518-0004 | Clip, Governor Control Rod to Carburetor | 28 | 526-0113 | Washer, Flat - Steel (11/32" I.D. x 1" O.D. x 3/32" Thick) |
| 14 | 167-0188 | Clip, Alternator Lead Support | 29 | 850-0045 | Washer, Spring Lock (5/16") |
| 15 | 191-1102 | Stator, Charging Alternator | 30 | 800-0028 | Screw, Hex Head Cap (5/16 - 18 x 1") |
| 16 | 813-0108 | Screw Round Head - Steel No. 10 - 32 x 1 - 1/2" | 31 | 134-3213 | Guard, Blower Housing |
| 18 | 870-0131 | Nut, Hex No. 10 - 32 | 32 | 815-0378 | Screw, Ind. Hex Head w/ET (No. 14 x 1/2") |

REPAIR PARTS

GT 18 TWIN GARDEN TRACTOR--MODEL NO. 917.257111 AND 917.257112
ONAN ENGINE--MODEL NO. B48M-GA018/3417A

IGNITION GROUP

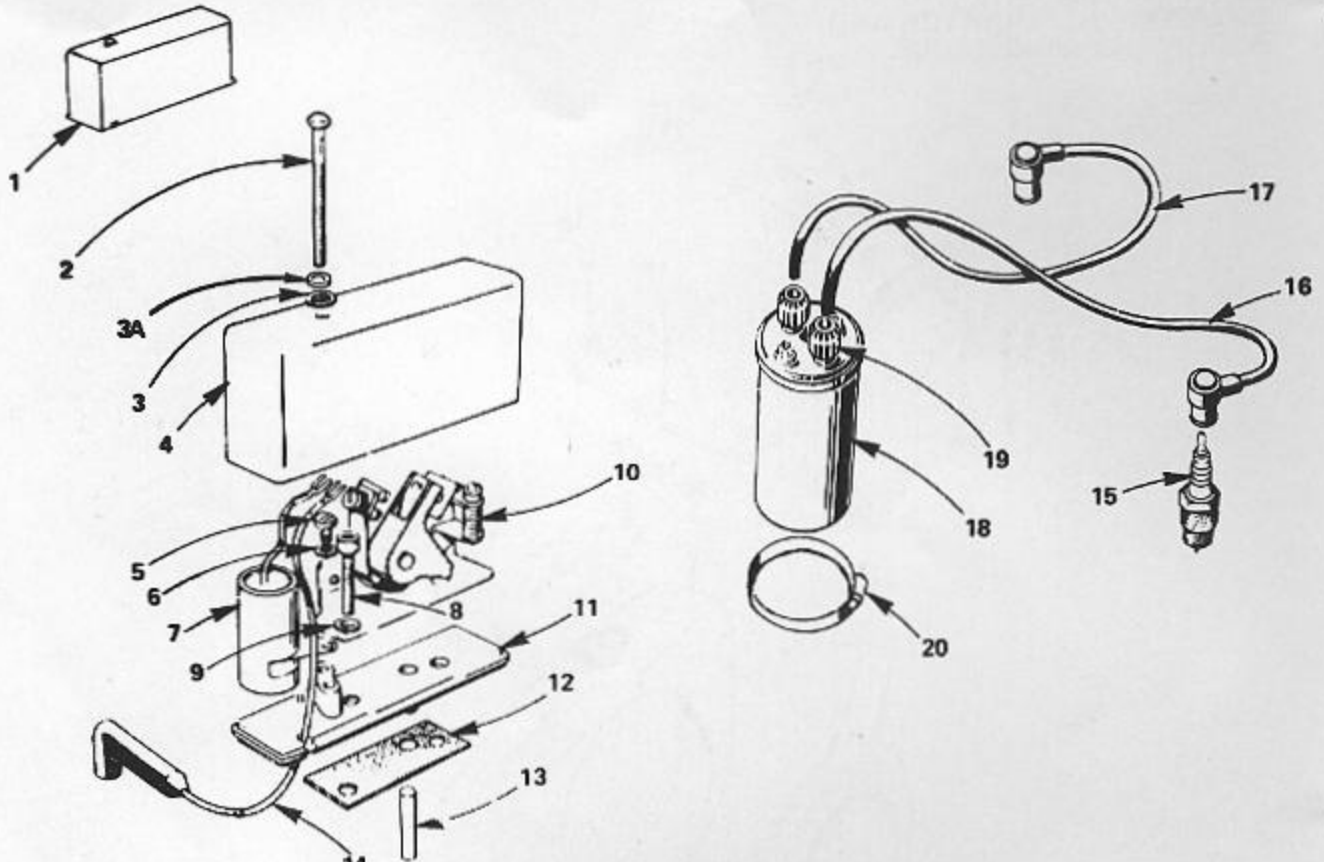

| KEY NO. | PART NO. | DESCRIPTION |
|---------|----------|---------------------------------------------------------|
| 1 | 160-1210 | Box Assembly, Breaker (Includes Parts Marked *) |
| 2 | 812-0108 | †*Screw, Machine - Round Head (No. 10 - 14 x 1 - 1/2") |
| 3 | 526-0008 | †*Washer, Flat (13/64" I.D. x 7/16" O.D. x 1/32" thick) |
| 3A | 509-0065 | †*Retainer, "O" Ring |
| 4 | 160-1232 | *Cover, Breaker Box |
| 5 | 815-0358 | *Screw, Tapping - Hex Head (No. 8 - 32 x 5/16") |
| 6 | 850-0025 | *Washer, Lock - Spring (No. 8) |
| 7 | 312-0196 | *Condenser, Ignition |
| 8 | 802-0034 | *Screw, Cap - Socket Head (1/4 - 20 x 3/4") |
| 9 | 850-0038 | *Washer, Lock - Spring - High Collar (1/4") |
| 10 | 160-1183 | *Point Assembly, Breaker |
| 11 | 160-1219 | *Base, Breaker Box |
| 12 | 160-1150 | +*Gasket, Breaker Box |
| 13 | 160-1151 | Plunger, Breaker Point Assembly |
| 14 | 336-2132 | Lead, Breaker Points to Coil |
| 15 | 167-0298 | Plug, Spark (Resistor Type) |
| 16 | 167-1595 | Cable, Spark Plug (17") |
| 17 | 167-1596 | Cable, Spark Plug (15") |
| 18 | 166-0535 | Coil, Ignition |
| 19 | 166-0604 | Nut, Coil Cable (Part of 166-0535 Coil) |
| 20 | 503-0311 | Clamp, Coil Mounting |

*PARTS INCLUDED IN 160-1210 BREAKER BOX ASSEMBLY.

+INCLUDED IN GASKET KIT 168-0130.

†INCLUDED IN 160-1232 COVER

REPAIR PARTS

GT 18 TWIN GARDEN TRACTOR--MODEL NO. 917.257111 AND 917.257112
ONAN ENGINE--MODEL NO. B48M-GA018/3417A

STARTER PARTS GROUP

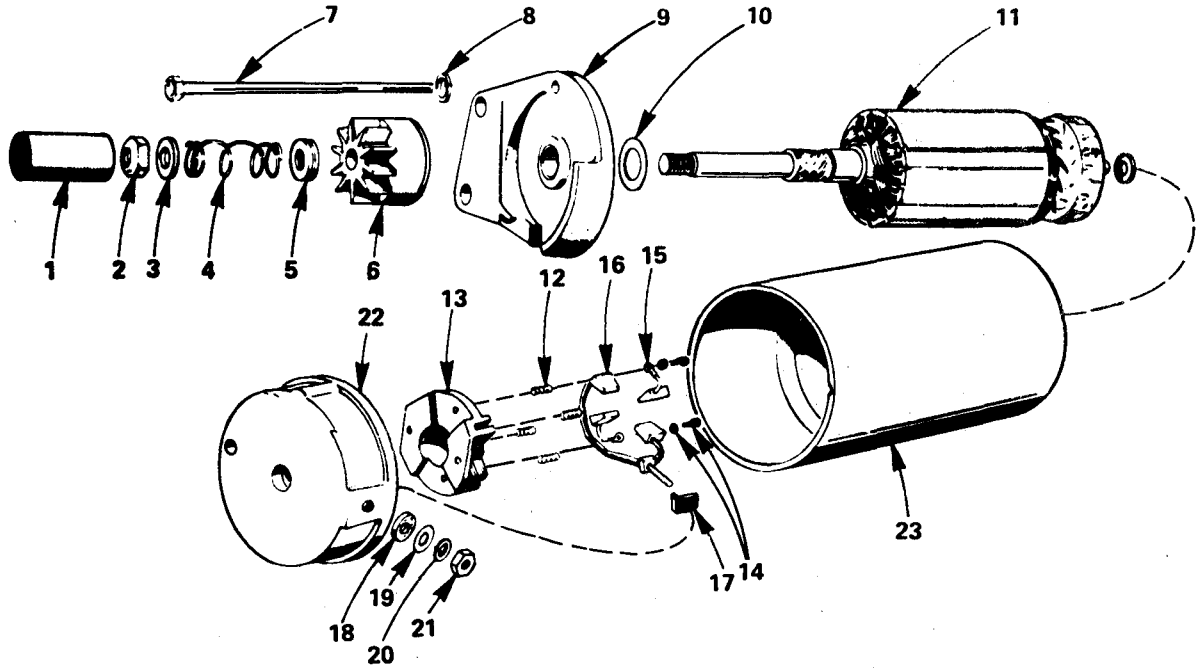

| KEY NO. | PART NO. | DESCRIPTION |
|---------|----------|--------------------------------------------------------------|
| | 191-0933 | Starter, 12 Volt (Complete) |
| 1 | 191-1034 | Cover, Dust |
| 2 | 191-1045 | Nut, Stop |
| 3 | 191-1046 | Washer, Stop Nut |
| 4 | 191-1035 | Spring, Anti-drift |
| 5 | 191-1047 | Spacer, Dust Cover |
| 6 | 191-1036 | Drive Assembly |
| 7 | 191-1048 | Screw, Hex Cap |
| 8 | 850-0040 | Washer, Lock |
| 9 | 191-1037 | Cap, Assembly, Drive End |
| 10 | 191-1038 | Washer, Armature Thrust |
| 11 | 191-1039 | Armature |
| 12 | ▲ | †*Spring, Brush |
| 13 | ▲ | †Brush Holder |
| 14 | ▲ | †Screw and Lockwasher |
| 15 | ▲ | †*Brush, Ground |
| 16 | ▲ | †*Stud and Brush Assembly, Input |
| 17 | ▲ | †Bushing, Insulation - Input Stud |
| 18 | ▲ | †Washer, Insulation - Input Stud |
| 19 | ▲ | †Washer, Flat - Input Stud |
| 20 | ▲ | †Washer, Lock - Input Stud |
| 21 | ▲ | †Nut, Securing - Input Stud |
| 22 | 191-1040 | Cap Assembly, Commutator (Includes Parts Marked †) |
| 23 | ▲ | Housing, Starter Motor |
| | 191-1041 | Repair Kit, Brush, Spring and Stud (Includes Parts Marked *) |

† - Included in the 191-1040 Cap Assembly.

* - Included in the 191-1041 Brush, Spring and Stud Kit.

▲ - Not Sold Separately

REPAIR PARTS

GT 18 TWIN GARDEN TRACTOR--MODEL NO. 917.257111 AND 917.257112
ONAN ENGINE--MODEL NO. B48M-GA018/3417A

CYLINDER BLOCK GROUP

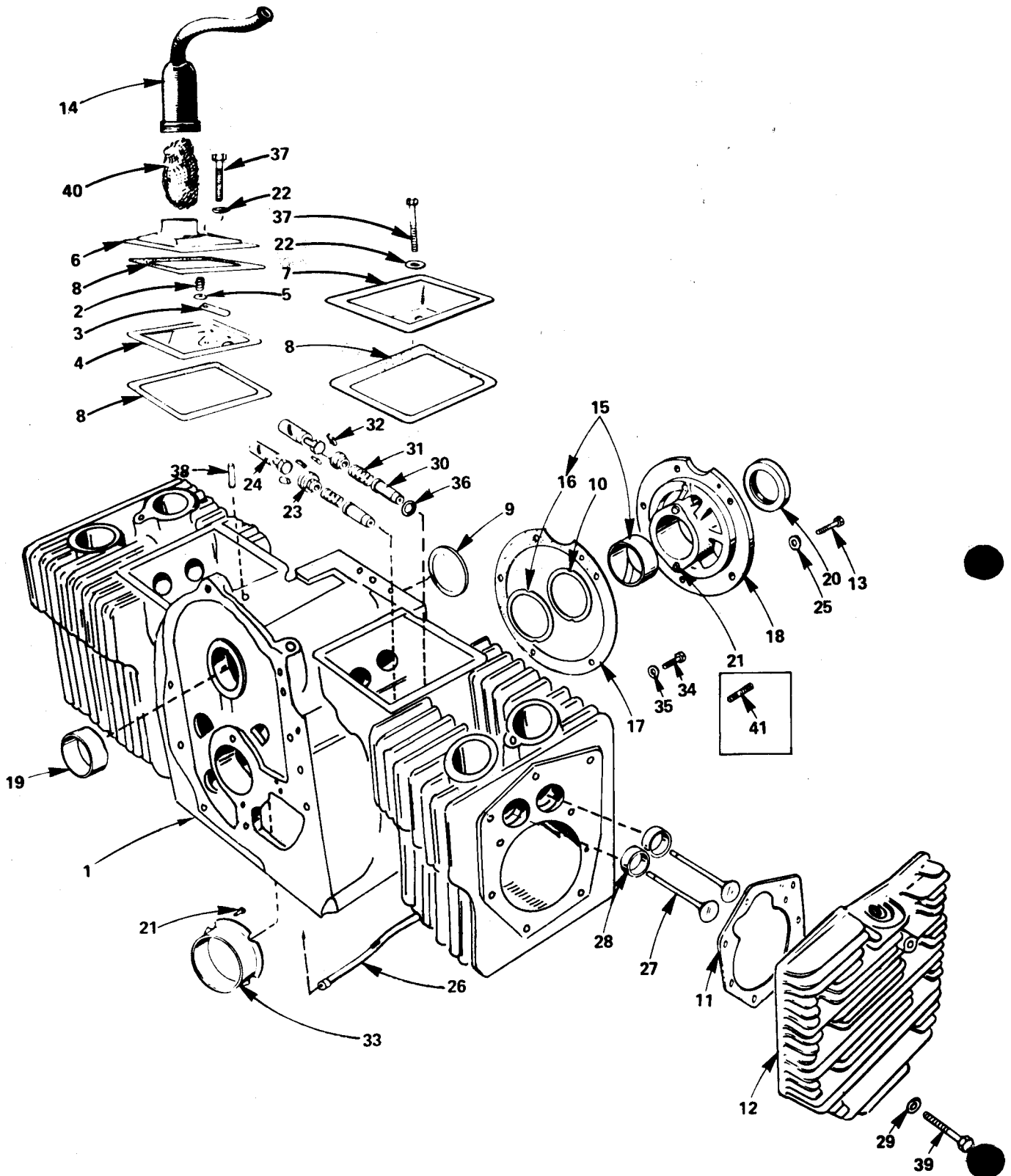

REPAIR PARTS

GT 18 TWIN GARDEN TRACTOR--MODEL NO. 917.257111 AND 917.257112
ONAN ENGINE--MODEL NO. B48M-GA018/3417A

CYLINDER BLOCK GROUP

| KEY NO. | PART NO. | DESCRIPTION | KEY NO. | PART NO. | DESCRIPTION |
|---------|-------------|----------------------------------------------------------------|-------------|----------|-----------------------------------------------------------------|
| 1 | 110-2621 | Block Assembly, Cylinder (Includes Parts Marked †) | 28 | | INSERT, VALVE SEAT EXHAUST |
| 2 | 123-1174 | Spring, Breather Valve | 110-1824 | | †Standard |
| 3 | 123-1175 | Valve, Breather | 110-1824-02 | | .002" Oversize |
| 4 | 123-1173 | Baffle, Breather | 110-1824-05 | | .005" Oversize |
| 5 | 526-0018 | Washer, Flat - Steel (17/64" I.D. x 5/8" O.D. x 1/16" Thick) | 110-1824-10 | | .010" Oversize |
| 6 | 110-2274 | Cover, Valve Compartment (L.H.) | 110-1824-25 | | .025" Oversize |
| 7 | 110-1879 | Cover, Valve Compartment (R.H.) | | | INTAKE |
| 8 | 110-1921 | xGasket, Valve Cover | 110-0197 | | †Standard |
| 9 | 517-0048 | †Plug, Extension - Camshaft | 110-0197-02 | | .002" Oversize |
| 10 | 104-0776 | †Shim, Rear Bearing Plate (.005") | 110-0197-05 | | .005" Oversize |
| 11 | 110-2287 | xGasket, Cylinder Head | 110-0197-10 | | .010" Oversize |
| 12 | | HEAD, CYLINDER | 110-0197-25 | | .025" Oversize |
| | 110-2564 | Right Side (No. 2 Cylinder) | 29 | 526-0122 | Washer, Flat - Steel (11/32" I.D. x 23/32" O.D. x 10 Gauge) |
| | 800-2563 | Left Side (No.1 Cylinder) | 30 | 110-1807 | †Guide, Valve |
| 13 | 800-0051 | †Screw, Hex Head Cap - Steel (3/8 - 16 x 1 - 1/4") | 31 | 110-0539 | Spring, Valve |
| 14 | 123-1277 | Tube, Breather | 32 | 110-0639 | Lock, Valve and Spring Retainer |
| 15 | | BEARING, CRANKSHAFT - REAR (INCLUDES THRUST WASHER) | 33 | | *BEARING, CRANKSHAFT - FRONT (FLANGED) |
| | 101-0450 | †Standard | 101-0432 | | †Standard |
| | 101-0450-02 | .002" Undersize | 101-0432-02 | | .002" Undersize |
| | 101-0450-10 | .010" Undersize | 101-0432-10 | | .010" Undersize |
| | 101-0450-20 | .020" Undersize | 101-0432-20 | | .020" Undersize |
| | 101-0450-30 | .030" Undersize | 101-0432-30 | | .030" Undersize |
| 16 | 104-0575 | †Washer, Crankshaft Bearing Thrust | 34 | 800-0046 | Screw, Hex Head Cap (3/8 - 16 x 3/4") - Cylinder Block Wet Hole |
| 17 | 101-0415 | x†Gasket, Bearing Plate | 35 | 526-0066 | Washer, Flat - Copper (25/64" I.D. x 9/16" O.D. x 1/16" O.D.) |
| 18 | 101-0439 | †Plate, Bearing (Excludes Bearings) | 36 | 110-0068 | x†Gasket, Valve Guide (Intake) |
| 19 | 101-0405 | †Bearing, Camshaft (Precision) | 37 | 800-0010 | Screw, Hex Head Cap (1/4 - 20 x 1 - 3/4") |
| 20 | 509-0041 | x†Seal, Bearing Plate | 38 | 149-1299 | Tube, Fuel Pump Vacuum |
| 21 | 516-0072 | †Pin, Main Bearing Stop | 39 | | SCREW, HEX HEAD CAP |
| 22 | 526-0063 | Washer, Flat - Copper (17/64" I.D. x 7/16" O.D. x 1/32" Thick) | | 800-0540 | 5/16 - 18 x 1 - 5/8" |
| 23 | 110-0893 | Retainer, Valve | | 800-0541 | 5/16 - 18 x 2" |
| 24 | | TAPPET, VALVE | 40 | 123-0865 | Filter, Breather Tube |
| | 115-0006 | Standard | 41 | 520-0820 | Stud, Cylinder Block Wet Hole (Lower) |
| | 115-0006-02 | .002" Oversize | | | |
| | 115-0006-05 | .005" Oversize | | | |
| 25 | 850-0050 | †Washer, Lock (3/8") | | | |
| 26 | 120-0735 | †Tube, Crankcase Oil | | | |
| 27 | | VALVE | | | |
| | 110-1808 | Intake | | | |
| | 110-1809 | Exhaust | | | |

† - Included in 110-2397 Cylinder Block Assembly.
* - Replacement Front Flange Bearing replaces unflanged bearing and thrust washer.
x - Included in Gasket Kit 168-0130

REPAIR PARTS

GT 18 TWIN GARDEN TRACTOR--MODEL NO. 917.257111 AND 917.257112
ONAN ENGINE--MODEL NO. B48M-GA018/3417A

CRANKSHAFT, FLYWHEEL, CAMSHAFT AND PISTON GROUP

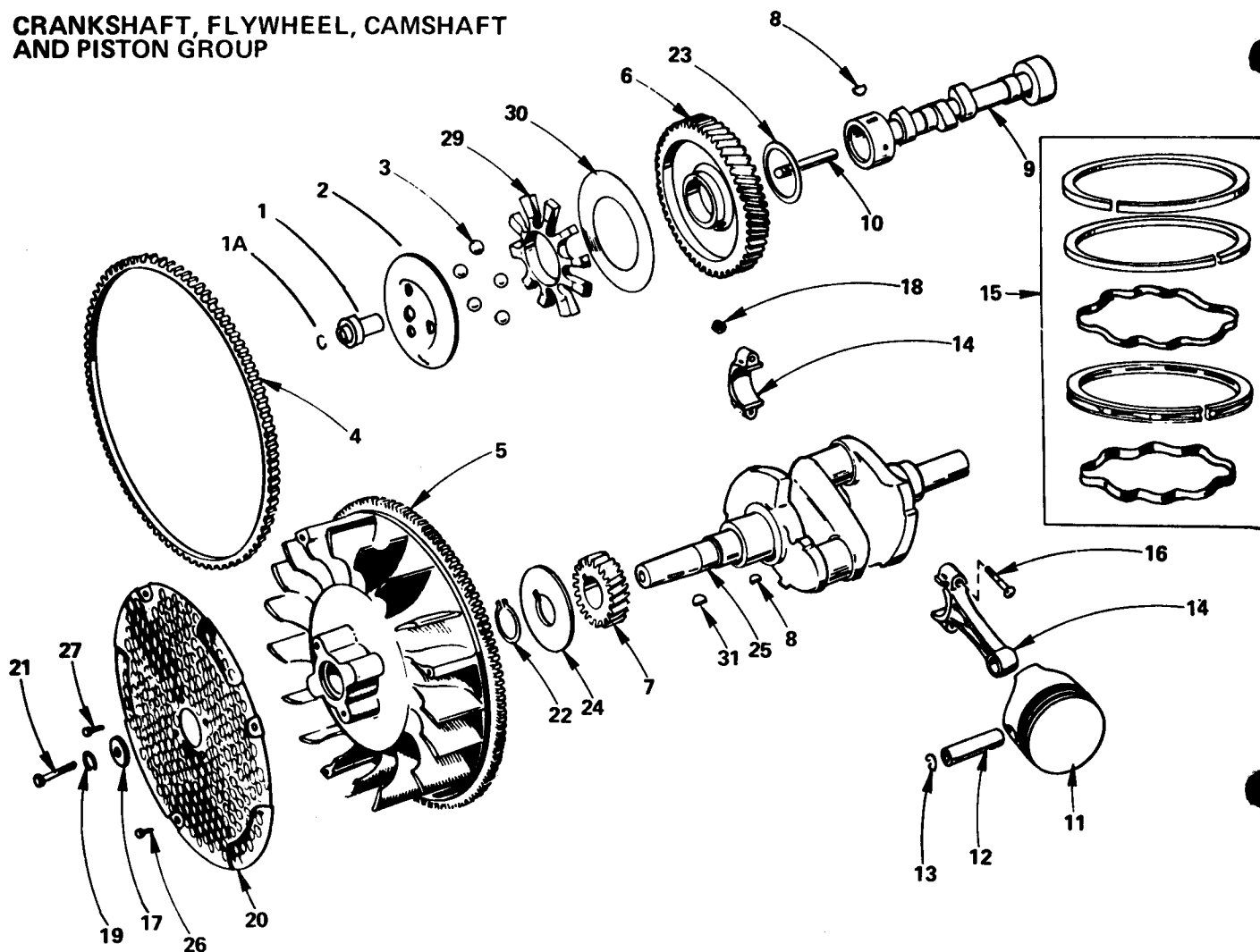

| KEY NO. | PART NO. | DESCRIPTION | KEY NO. | PART NO. | DESCRIPTION |
|---------|-------------|----------------------------------------------------|---------|-------------|---------------------------------------------------------------|
| 1 | 150-1519 | Hub | 15 | | RING SET, PISTON |
| 1A | 150-0078 | Ring, Camshaft Center Pin | | 113-0189 | Standard |
| 2 | 150-1520 | Cup, Governor | | 113-0189-05 | .005" Oversize |
| 3 | 510-0015 | Ball, Fly - Governor | | 113-0189-10 | .010" Oversize |
| 4 | 104-0779 | Gear, Ring - Flywheel | | 113-0189-20 | .020" Oversize |
| 5 | 134-3506 | Flywheel (Includes Ring Gear and Magnet Ring) | | 113-0189-30 | .030" Oversize |
| 6 | 105-0332 | Gear, Camshaft (Includes Flyball Spacer and Plate) | | 113-0189-40 | .040" Oversize |
| 7 | 104-0032 | Gear, Crankshaft | 16 | 114-0240 | Bolt, Special - Connecting Rod |
| 8 | 515-0001 | Key (1/2" Diameter x 1/8") | 17 | 526-0017 | Washer, Flat Steel (15/32" I.D. x 1 - 1/4" O.D. x 1/4" Thick) |
| 9 | 105-0402 | Camshaft (Includes Center Pin) | 18 | 870-0302 | Nut, Locking (5/16 - 24) |
| 10 | 150-0075 | Pin, Camshaft Center | 19 | 850-0055 | Washer, Spring Lock (7/16") |
| 11 | | PISTON AND PIN (INCLUDES RETAINING RINGS) | 20 | 134-3508 | Guard, Flywheel |
| | 112-0151 | Standard | 21 | 104-0170 | Screw, Hex Head Cap (7/16 - 14 x 4") |
| | 112-0151-05 | .005" Oversize | 22 | 518-0014 | Ring, Retaining - Crankshaft Gear Washer |
| | 112-0151-10 | .010" Oversize | 23 | 105-0004 | Washer, Camshaft Gear Thrust |
| | 112-0151-20 | .020" Oversize | 24 | 104-0043 | Washer, Crankshaft Gear Retainer |
| | 112-0151-30 | .030" Oversize | 25 | 104-0996 | Crankshaft |
| | 112-0151-40 | .040" Oversize | 26 | 815-0400 | Machine Screw Truss Head |
| 12 | 112-0122 | Pin, Piston | 27 | 821-0014 | Screw, Hex Head Cap - Locking Flange (5/16 - 18 x 1/2") |
| 13 | 518-0311 | Ring, Piston Pin Retaining | 29 | 150-1257 | Spacer, Governor Flywheel |
| 14 | | ROD ASSEMBLY, CONNECTING | 30 | 150-0077 | Plate, Governor Flyball |
| | 114-0257 | Standard | 31 | 515-0227 | Key Kit |
| | 114-0257-10 | .010" Oversize | | | |
| | 114-0257-20 | .020" Oversize | | | |
| | 114-0257-30 | .030" Oversize | | | |

REPAIR PARTS

GT 18 TWIN GARDEN TRACTOR--MODEL NO. 917.257111 AND 917.257112
ONAN ENGINE--MODEL NO. B48M-GA018/3417A

GEAR COVER, OIL BASE AND OIL PUMP GROUP

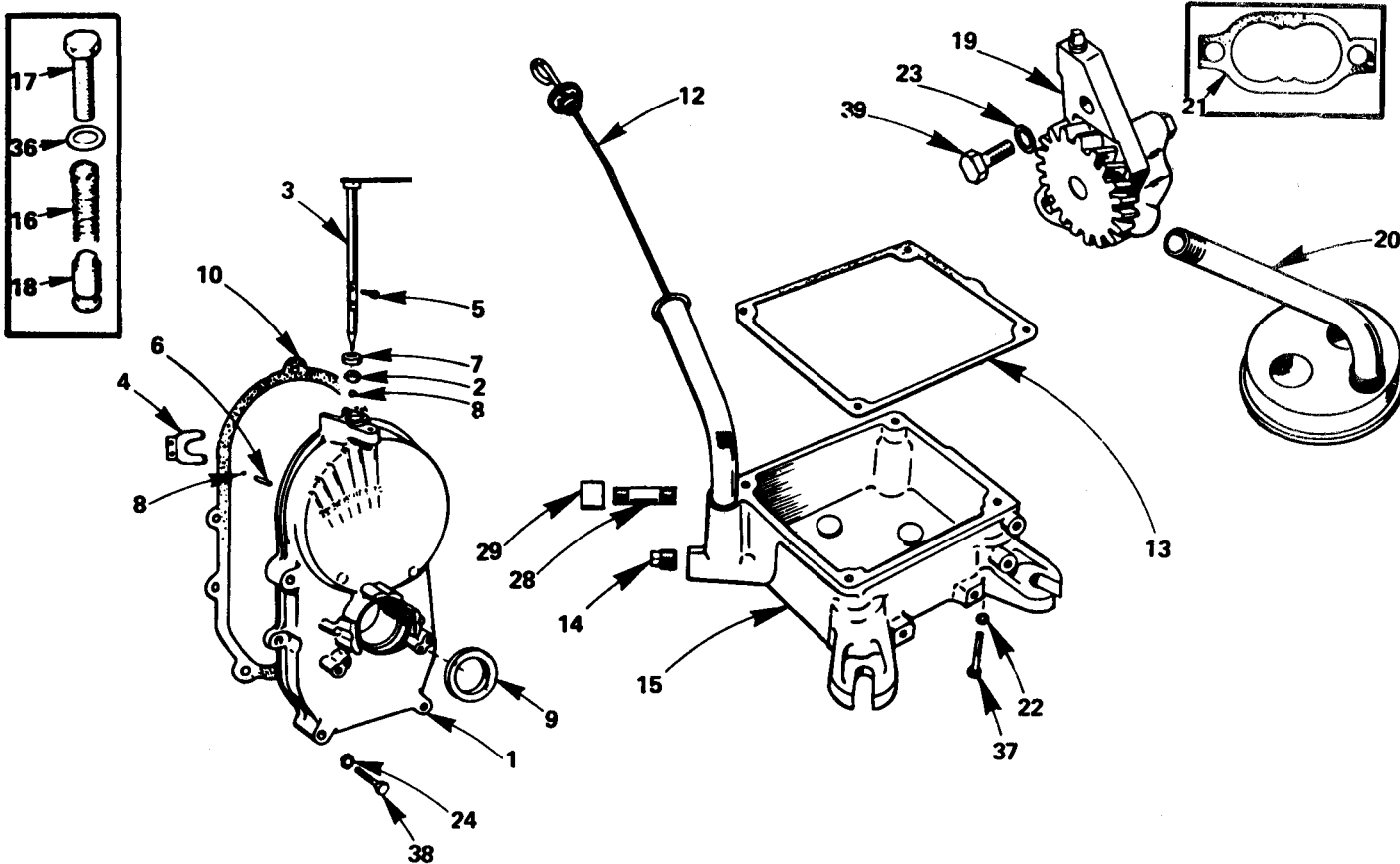

| KEY NO. | PART NO. | DESCRIPTION | KEY NO. | PART NO. | DESCRIPTION |
|---------|----------|--------------------------------------------------------------------------|---------|----------|----------------------------------------------------------------------------------|
| 1 | 103-0498 | Cover Assembly, Gear (Includes Parts Marked *) | 21 | 120-0161 | +Gasket Kit, Oil Pump |
| 2 | 510-0105 | *Bearing, Governor Shaft | 22 | 850-0050 | Washer, Spring Lock (3/8") |
| 3 | 150-1470 | *Shaft and Arm Assembly, Governor | 23 | 850-0040 | Washer, Spring Lock (1/4") |
| 4 | 150-1187 | *Yoke Governor Shaft | 24 | 526-0065 | Washer, Flat - Copper (21/64" I.D. x 9/16" O.D. x 1/16" Thick) |
| 5 | 815-0046 | *Screw, Yoke Retaining | 28 | 505-0176 | Nipple, Pipe - Oil Drain (1/2 x 3-1/2") |
| 6 | 516-0130 | *Pin, Governor Cup Stop | 29 | 505-0158 | Cap, Pipe (1/2") |
| 7 | 509-0008 | +*Seal, Oil - Governor Shaft | 36 | 526-0066 | Washer, Flat - Copper (25/64" I.D. x 9/16" O.D. x 1/16" Thick) - By - Pass Valve |
| 8 | 510-0014 | *Ball, Bearing - Governor Shaft | 37 | 800-0056 | Screw, Hex Head Cap (3/8 - 16 x 2 - 1/2") |
| 9 | 509-0040 | +*Seal, Gear Cover | 38 | 800-0032 | Screw, Hex Head Cap (5/16 - 18 x 1 - 3/4") - Gear Cover Mounting |
| 10 | 103-0408 | +Gasket, Gear Cover | 38 | 800-0545 | Screw, Hex Head Cap (5/16 - 18 x 2 - 3/4") - Gear Cover Mounting |
| 12 | 123-1292 | Cap and Indicator, Oil Fill | 39 | 800-0007 | Screw, Hex Head Cap (1/4 - 20 x 1") |
| 13 | 102-0693 | +Gasket, Oil Base Mounting | | | |
| 14 | 505-0056 | Plug, Oil Drain | | | |
| 15 | | BASE, OIL | | | |
| | 102-0741 | For Engines With Extended Oil Drain | | | |
| 16 | 120-0140 | Spring, Oil By-Pass Valve | | | |
| 17 | 801-0050 | Screw, Hex Head Cap (3/8 - 24 x 1") - Oil By - Pass Valve, Oil By - Pass | | | |
| 18 | 120-0398 | Pump, Oil - Complete (NOTE: Internal parts not sold separately) | | | |
| 19 | 120-0491 | | | | |
| 20 | 120-0713 | Intake, Oil Pump (Includes: Cup, Screen and Pipe) | | | |

* - Included in Gear Cover Assembly.
+ - Included in Gasket Kit, page 29.

Sears

**MODEL NOS.
917.257111
AND
917.257112**

HOW TO ORDER REPAIR PARTS

MODEL NUMBER

The Model Number will be found on the Model Plate attached to the Battery Heat Shield, in front of the Battery. Always mention the Model Number when requesting service or repair parts for your Garden Tractor.

REPAIR PARTS

All parts listed herein may be ordered from any SEARS, ROEBUCK AND CO. retail or catalog store.

WHEN ORDERING REPAIR PARTS, ALWAYS GIVE THE FOLLOWING INFORMATION:

- THE PART NUMBER
- THE PART DESCRIPTION
- THE MODEL NUMBER
- THE NAME OF MERCHANDISE

If the parts you need are not stocked locally, your order will be electronically transmitted to a Sears Repair Parts Distribution Center for "expedited handling".



SEARS SERVICE

Sears, Roebuck and Co., Chicago, Ill. 60684, U.S.A.