

**Sears**

**OWNER'S  
MANUAL**

**MODEL NO.  
922.261660**

*V Belt 10500*

READ INSTALLATION  
AND MAINTENANCE  
INSTRUCTIONS CAREFULLY

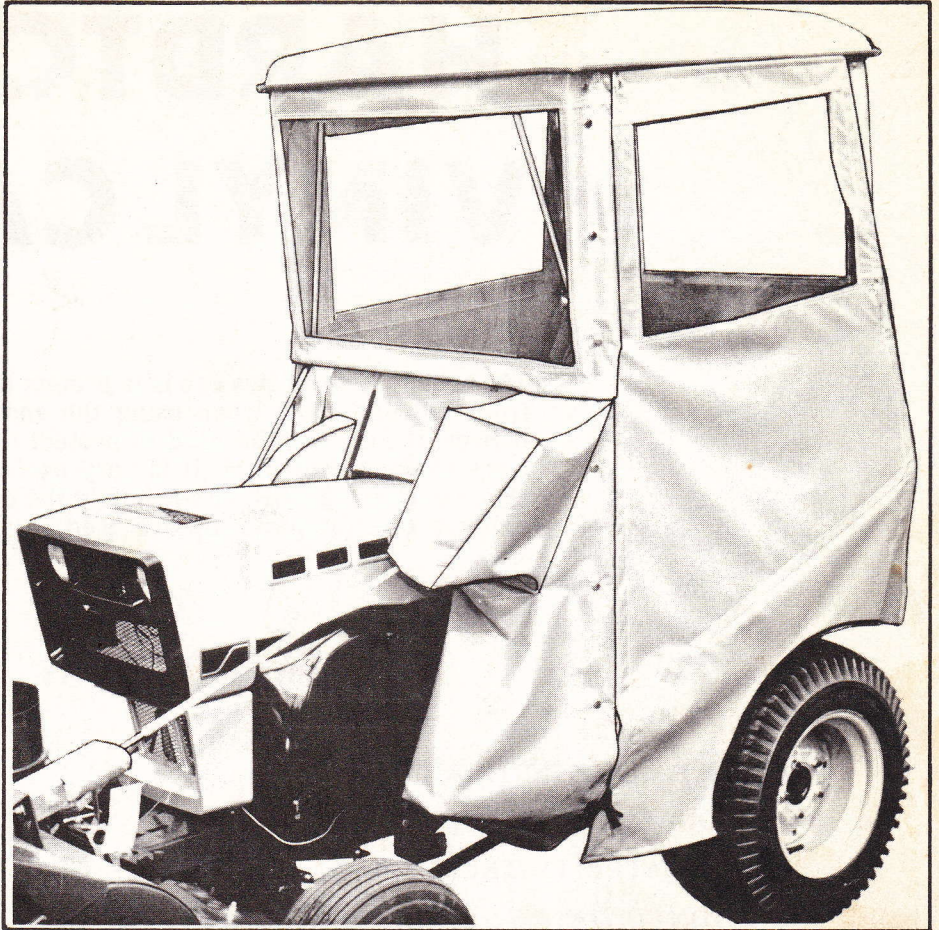

**HARDTOP  
VINYL CAB**

- **INSTALLATION**
- **MAINTENANCE**
- **REPLACEMENT PARTS**

**Sears, Roebuck and Co., Chicago, Ill. 60684 U.S.A.  
and Simpsons Sears Limited, Toronto, Canada**

**NO. 7880 (8/78)**

1727#1

PRINTED IN U.S.A.

# HARDTOP VINYL CAB

The principal use of this cab is to protect the operator from swirling snow when using the snow blade or blower. It may also be used to protect the operator from blowing cold wind. It is very useful as a sunshade during hot weather when only the frame of the cab and the fiberglass top are used.

## TABLE OF CONTENTS

MAINTENANCE INSTRUCTIONS .....	2
OPTIONAL ACCESSORIES .....	2
INSTALLATION INSTRUCTIONS .....	3-9
CARTON CONTENTS & DIAGRAM .....	10-11
REPLACEMENT PARTS ORDERING .....	12

### MAINTENANCE INSTRUCTIONS:

1. Periodically check to see that bolts are tight. If one or more bolts come loose, breakage of cab parts might occur.
2. Door latches should be lightly oiled for proper operation.
3. Avoid rubbing contact with plastic windows. Keep plastic windows clean by washing them only with clear running water and by rubbing with your bare hands, only. The use of a rag, sponge, or brush may scratch the plastic. Liquid soap may also be useful in cleaning windows. In storing parts, AVOID FOLDING PLASTIC. DO NOT CLEAN PLASTIC WINDOWS WHEN DRY!
4. Vinyl portions may be washed with the use of a brush or rag, hot or cold water, and with or without liquid soap.

### OPTIONAL ACCESSORIES

Optional Accessories are available at most SEARS stores:

GLASS WINDSHIELD with WIPER ..... 26168  
FLASHING AMBER CAUTION LIGHT ..... 26169

**INSTALLATION INSTRUCTIONS**

**TOOLS REQUIRED FOR CAB INSTALLATION:**

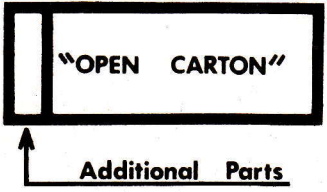

- 1. ELECTRIC DRILL
- 2. 9/32" DRILL BIT
- 3. 1/4" WRENCH (1)
- 4. 7/16" WRENCH (2)
- 5. 9/16" WRENCH (2)
- 6. 3/4" WRENCH (1)
- 7. OIL CAN

(WRENCHES CAN BE OPEN END OR SOCKET)

PLEASE NOTE: In these instructions, unless otherwise specified,

"BOLT" means 1/4" x 3/4" bolt (PART 26)

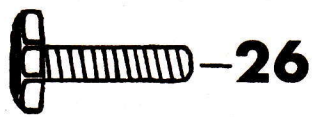

"NUT" means 1/4" nut (PART 24)



STEP 1: SEE FIG. 1:

LAY OUT ALL METAL PARTS IN THE ARRANGEMENT SHOWN.

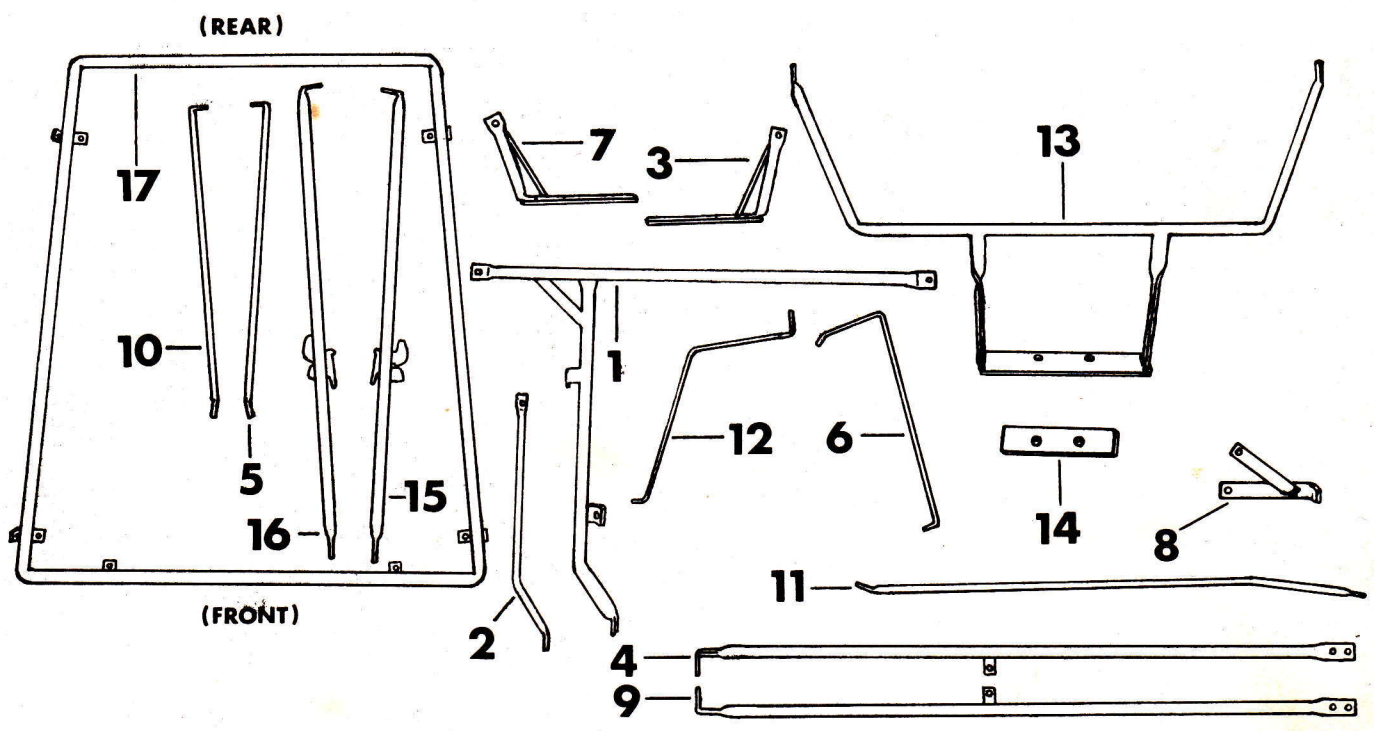

FIGURE 1

another free manual from [www.searstractormanuals.com](http://www.searstractormanuals.com)

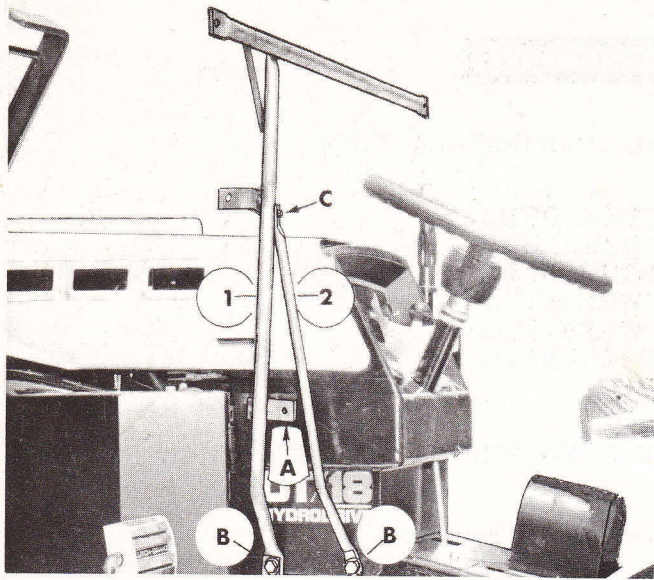

FIGURE 2

**STEP 2: SEE FIGURE 2:**

- A. Loosen two tractor bolts indicated by "B"; add PART 1 under the washer; add PART 2 under the washer. DO NOT TIGHTEN BOLTS YET.
- B. Remove sheet metal screw "C" from PART 1 and re-use it to attach upper end of PART 2 to PART 1. Now TIGHTEN TRACTOR BOLTS SECURELY AS REFERRED TO IN STEP A.
- C. After complete cab has been installed, you may wish to drill a hole into tractor (indicated by "A"), and use a bolt and nut (PARTS 26 & 24) to attach PART 1 to the tractor for greater stability. HOWEVER, THIS STEP IS NOT ABSOLUTELY NECESSARY, ALTHOUGH IT WILL HELP PROLONG THE LIFE OF THE CAB.

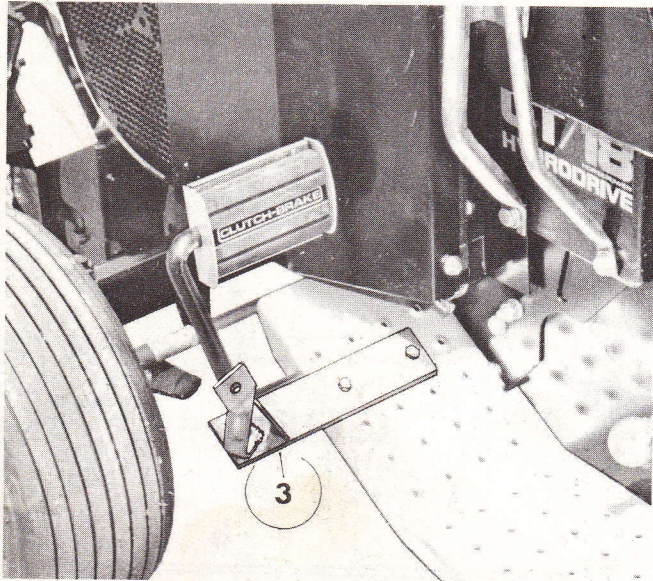

FIGURE 3

**STEP 3: SEE FIGURE 3:**

- A. Use a bolt and nut (PARTS 26 & 24) to attach PART 3 to the proper holes of the LEFT HAND foot rest, as shown.

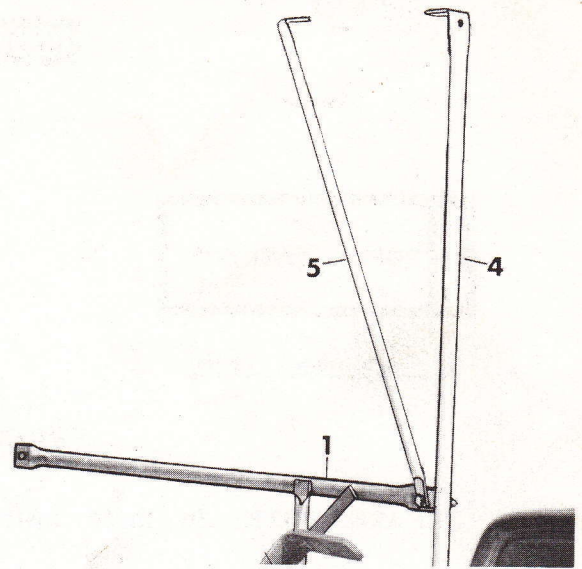

FIGURE 4

**STEP 4: SEE FIGURE 4:**

- A. Use a bolt and nut (PARTS 26 & 24): pass bolt thru lower end of PART 5, then thru clip welded to PART 4, then thru left hand end of PART 1. Add a nut to the bolt. TIGHTEN BOLT TO HOLD PART 5 in an upright position, leaning slightly toward center of tractor. PART 4 will have the head of a pre-inserted sheet metal screw toward the tractor seat.

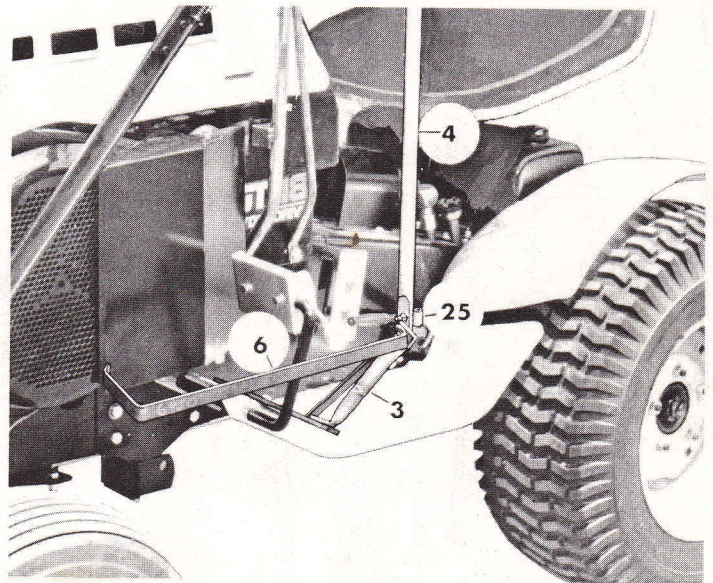

FIGURE 5

**STEP 5: SEE FIGURES 5 & 6:**

- A. Use a bolt and nut (PARTS 26 & 24): pass a bolt thru bottom hole of PART 4, then thru upper hole of PART 3, then thru PART 6. Add a nut and tighten so PART 6 is level with the ground.
- B. Use a bolt and nut (PARTS 26 & 24) to attach PART 25 to second hole from bottom of PART 4.

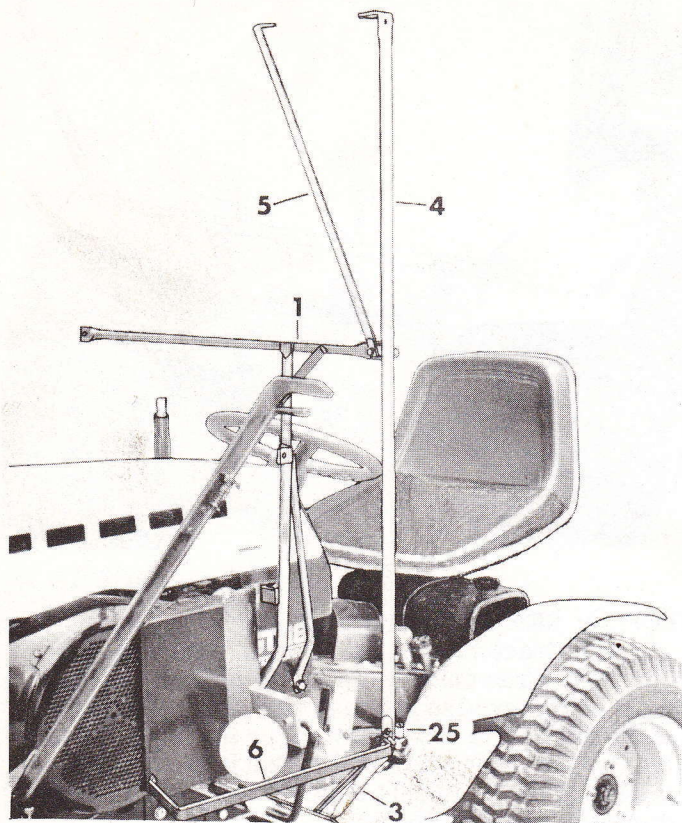

FIGURE 6

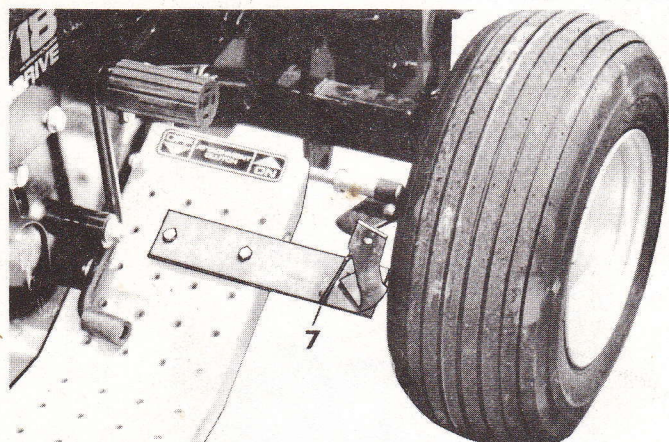

FIGURE 7

**STEP 6: SEE FIGURE 7:**  
A. Use bolts and nuts (PARTS 26 & 24) to attach PART 7 to RIGHT HAND tractor foot rest, using holes in foot rest shown here.

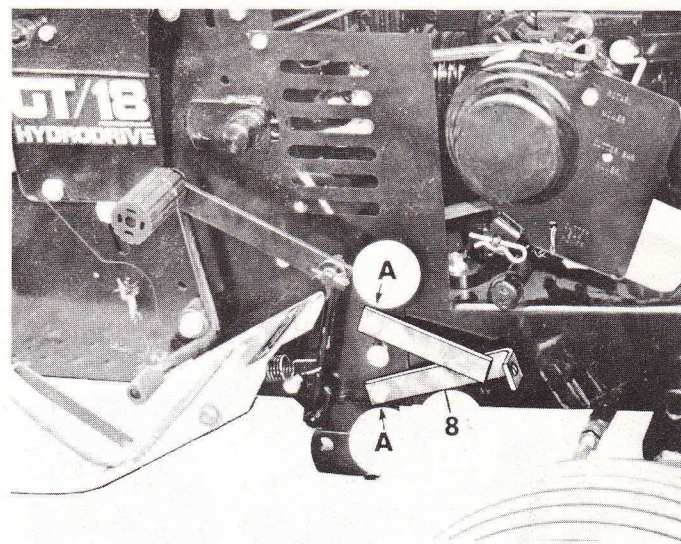

FIGURE 8

**STEP 7: SEE FIGURE 8:**  
A. Remove two tractor bolts indicated by "A" and re-use them to attach PART 8 to the tractor. Tighten the bolts very securely, with lockwashers in place.

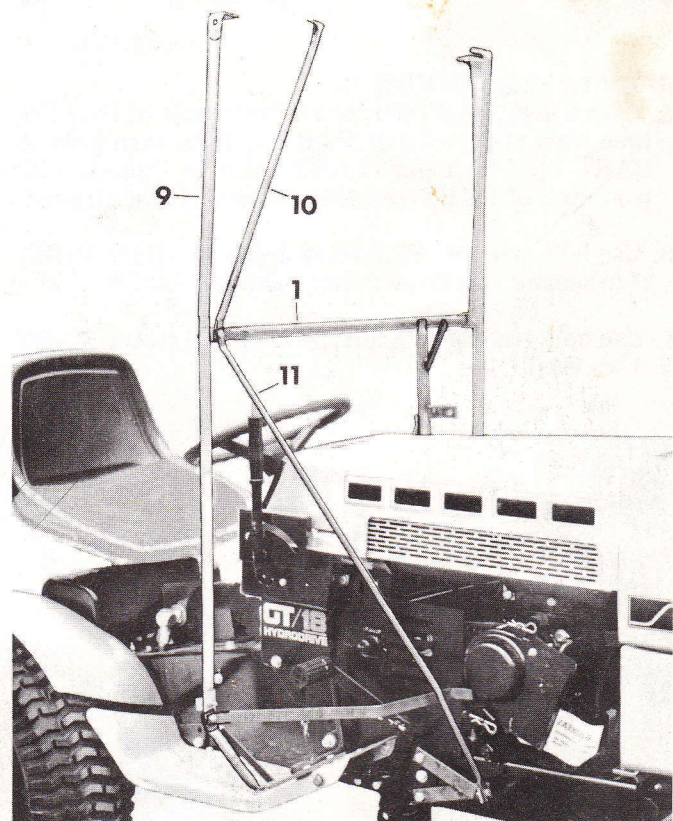

FIGURE 9

**STEP 8: SEE FIGURE 9:**  
A. Pass a bolt (PART 26) thru upper end of PART 11, then thru lower end of PART 10, then thru clip welded to PART 9, then thru right hand end of PART 1. Add nut (PART 24) and tighten enough to hold PART 10 in an upright position.

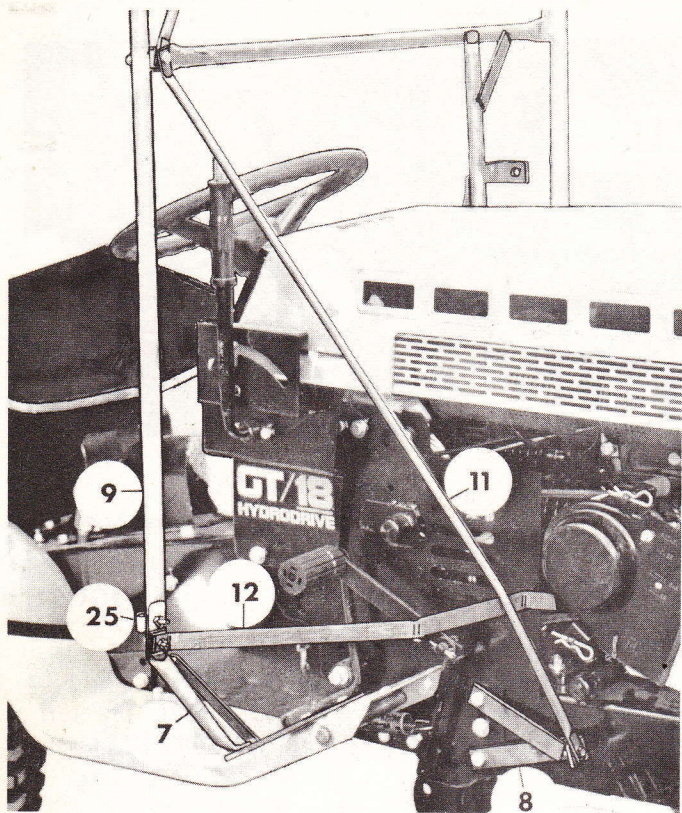

FIGURE 10

**STEP 9: SEE FIGURE 10:**

- A. Pass a bolt (PART 26) thru bottom hole of PART 9, then thru upper end of PART 7, then thru hole in PART 12. Add a nut (PART 24) and tighten with front end of PART 12 being level with the ground.
- B. Use bolt and nut (PARTS 26 & 24) to attach PART 25 to second hole from bottom end of PART 9.
- C. Use bolt and nut (PARTS 26 & 24) to attach PART 11 to PART 8.

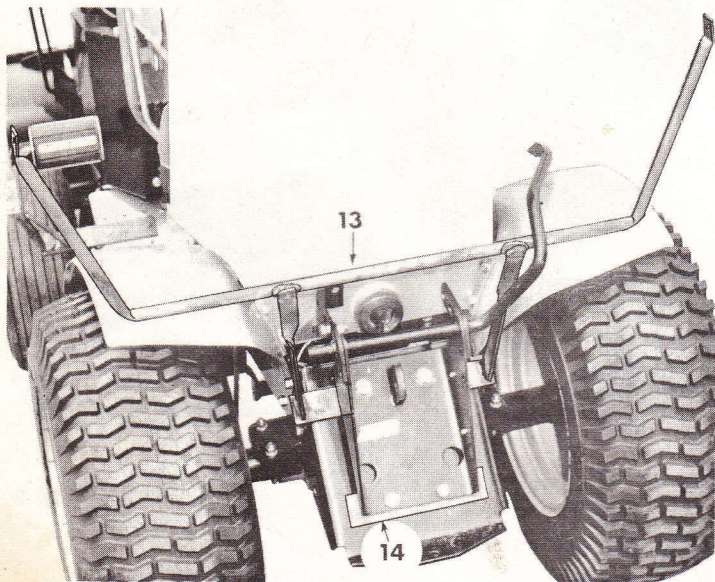

FIGURE 11

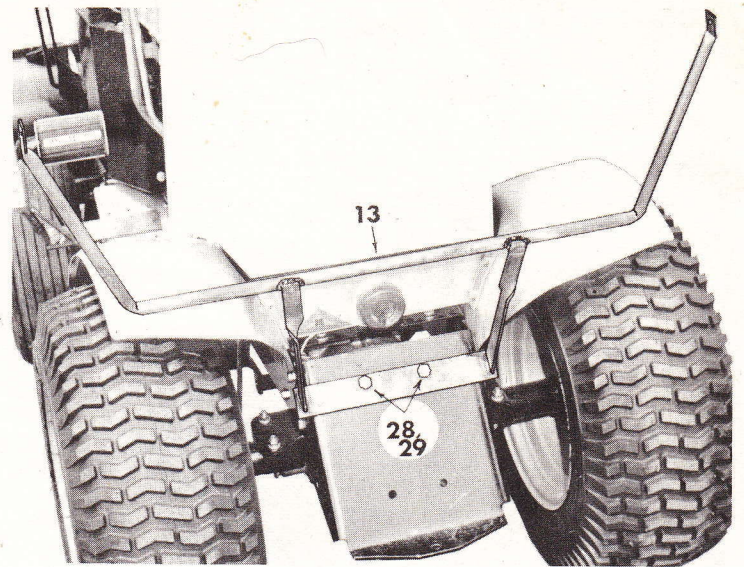

FIGURE 12

**STEP 10: SEE FIGURES 11 & 12:**

- A. If your tractor is equipped with either a hand-operated three-point hitch or an electric hitch, it must be removed so you may attach PARTS 13 & 14 to the hitch plate and re-mount the three-point hitch bracket, re-using the hitch bracket bolts. Make sure to place PARTS 13 & 14 between hitch bracket and the hitch plate as shown.
- B. If your tractor is not equipped with a three-point hitch, use two 1/2" x 1 1/4" bolt and washer (PARTS 28 & 29) from PARTS BAG to attach PART 13 to tractor hitch plate.

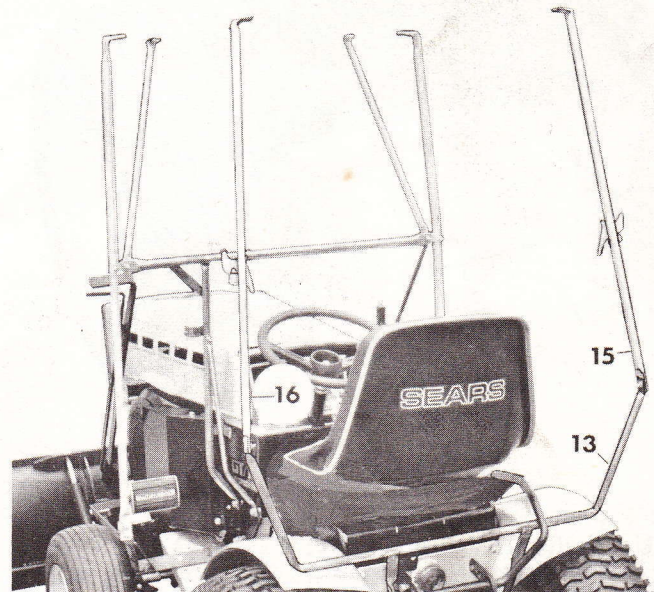

FIGURE 13

**STEP 11: SEE FIGURE 13:**

- A. Use bolts and nuts (PARTS 26 & 24) to attach PARTS 15 & 16 to PART 13. Tighten bolts enough to hold parts in an upright position, leaning slightly forward. NOTICE THAT DOOR LATCHES ARE ON FORWARD FACES OF PARTS 15 & 16, WITH THE BENT UPPER ENDS OF PARTS 15 & 16 POINTING TOWARD EACH OTHER.

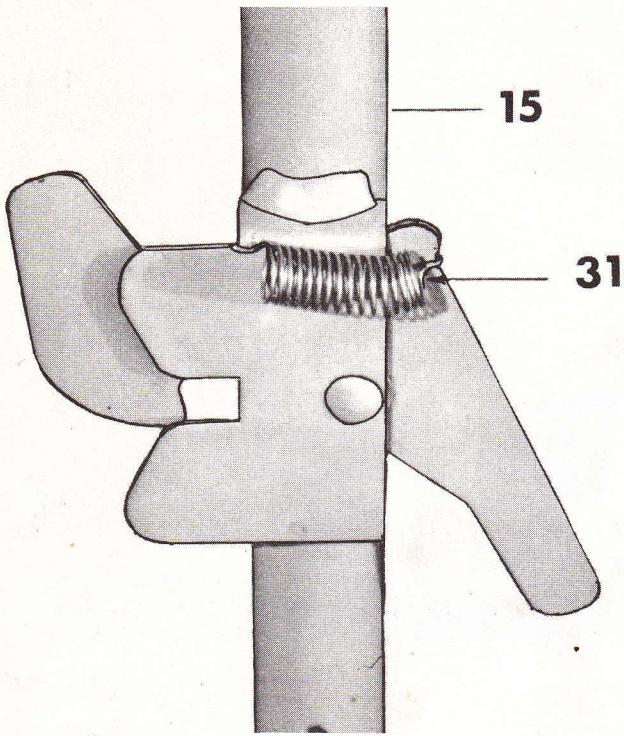

FIGURE 14

**STEP 12: SEE FIGURE 14:**

A. Shown is a portion of PART 15, with a spring, PART 31, attached. The spring is found in the PARTS BAG. Apply a spring to each door latch as shown. A drop of oil on the rivet of each door latch will help in the operation of the latch.

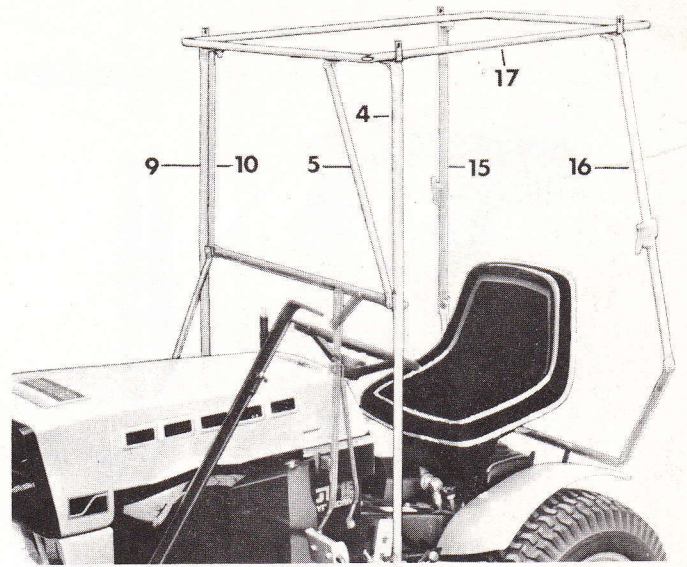

FIGURE 15

**STEP 13: SEE FIGURE 15:**

A. Use bolts and nuts (PARTS 26 & 24) to attach PART 17 (TOP FRAME) to upper ends of four CORNER POSTS (PARTS 4, 9, 15, & 16) and two TOP BRACES (PARTS 5 & 10). ("FRONT" of TOP FRAME is WIDER than "REAR" of TOP FRAME.) Tighten all six bolts securely.

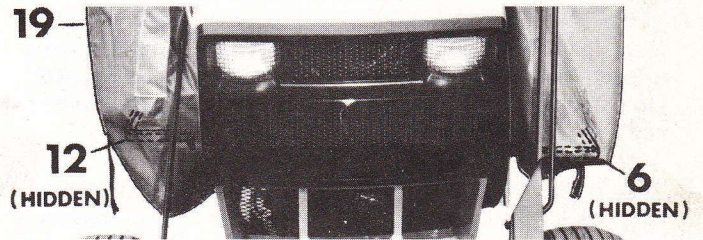

FIGURE 17

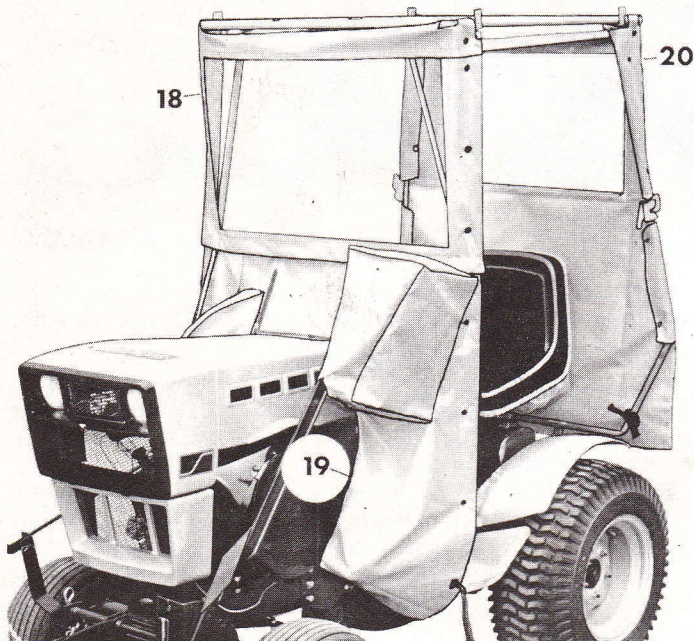

FIGURE 16

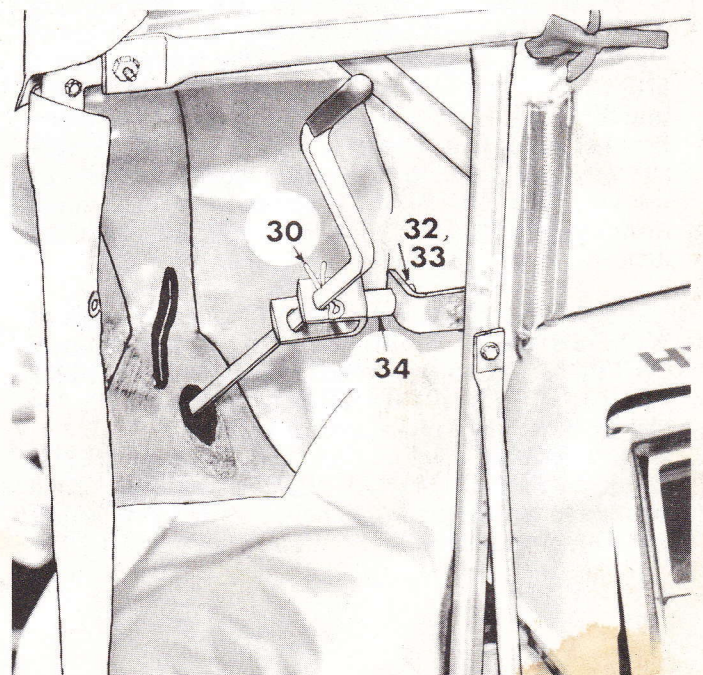

FIGURE 18

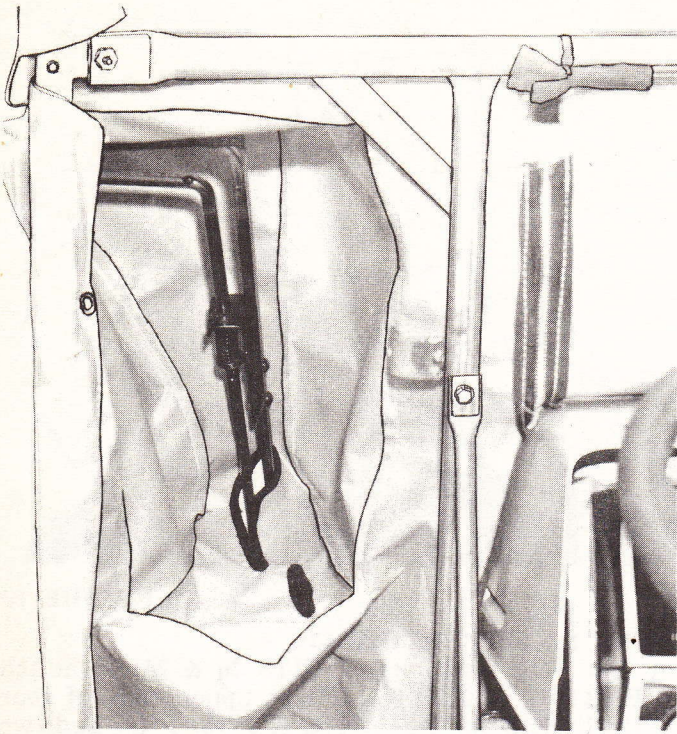

FIGURE 19

STEP 14: SEE FIGURES 16, 17, 18, & 19:

A. Place PART 18 (WINDSHIELD) into position (zippered edge is the bottom). Snap only the two upper snaps to front, side sections of TOP FRAME. Do the same thing with the REAR CURTAIN at the rear of the cab.

B. To install PART 19 (FRONT PANEL VINYL) correctly, front mounted blade or snow blower controls must be placed thru proper openings in FRONT PANEL VINYL before it is zippered to the lower edge of the WINDSHIELD. SEE FIGURE 18 if snowthrower attachment was previously mounted: remove the snowthrower discharge chute control crank support arm from the tractor. Use a 5/16" x 1 1/2" bolt (PART 33), 5/16" nut (PART 32), and SPACER (PART 34) to attach the "U" shaped bracket as shown. Place a COTTER PIN (PART 30) thru the hole in the chute control crank as shown. (SEE FIGURE 19 if you have a dozer blade attachment. Use LEFT HAND 5" slit for dozer lift arm.)

C. Zipper FRONT PANEL VINYL to lower edge of WINDSHIELD. Place lower sections around PARTS 6 & 12. Snap WINDSHIELD and FRONT PANEL VINYL to FRONT CORNER POSTS. Tie strings near the zipper are to be tied to PART 1. Underneath the tractor, find the SPRING STRAPS sewed to FRONT PANEL VINYL and hook those springs to tractor frame to hold FRONT PANEL in a well-fitting position.

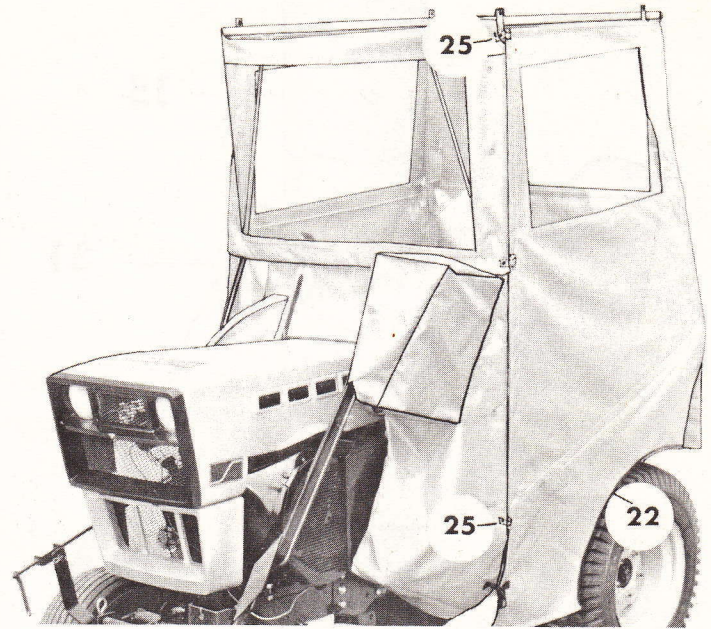

FIGURE 20

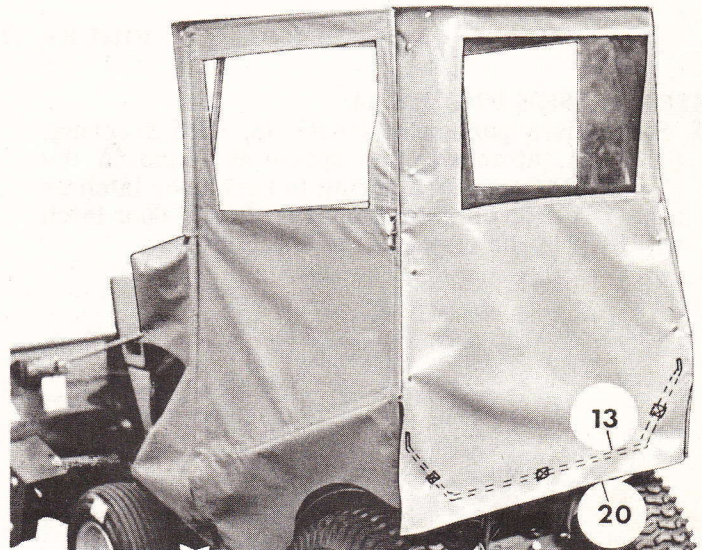
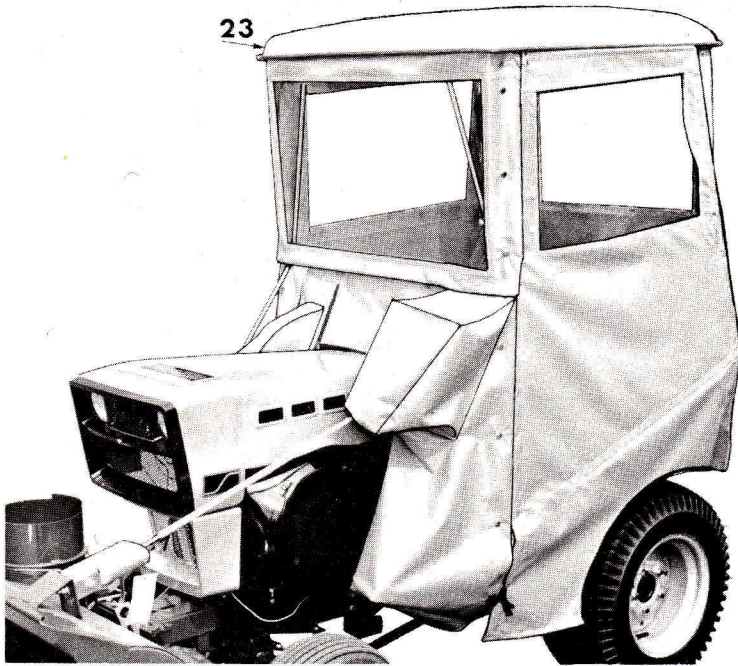

FIGURE 21

STEP 15: SEE FIGURES 20 & 21:

A. Snap REAR CURTAIN to REAR CORNER POSTS and tie strings to PART 13.

B. Insert bottom, front corner of each DOOR into the bottom HINGE (PART 25). Adjust the mid-point hinge on door frame so it may be bolted to FRONT CORNER POSTS (PARTS 4 or 9) using screws already in posts. Place another DOOR HINGE (PART 25) over upper corner of each door and use bolts and nuts (PARTS 26 & 24) to attach to upper end of FRONT CORNER POSTS.



**FIGURE 22**

**STEP 16: SEE FIGURE 22:**

- A. Place FIBERGLASS TOP (PART 23) over the TOP FRAME, with the upper edge of the WINDSHIELD and REAR CURTAIN laying on top of the TOP FRAME. When the FIBERGLASS TOP is pulled downward, it will "trap" the rods sewed into the upper hem of the WINDSHIELD and REAR CURTAIN, thereby holding them up.
- B. Place a 1/4" flat washer (PART 27) over each of four bolts (PART 26) and insert them thru holes provided in FIBERGLASS TOP and TOP FRAME. Add nuts, but do not tighten yet.
- C. Adjust FIBERGLASS TOP so it will almost touch top of each door when opening and closing each door. With that small clearance, tighten all four bolts.
- D. Tie strings near bottom, front corner of doors to strings sewed to FRONT PANEL VINYL.
- E. Check every bolt of cab at this time to make sure it is tight. Re-check tractor bolts which were loosened for cab installation to make sure they are securely tightened.

# HARDTOP VINYL CAB—MODEL NO. 922.261660

another free manual from [www.searstractormanuals.com](http://www.searstractormanuals.com)

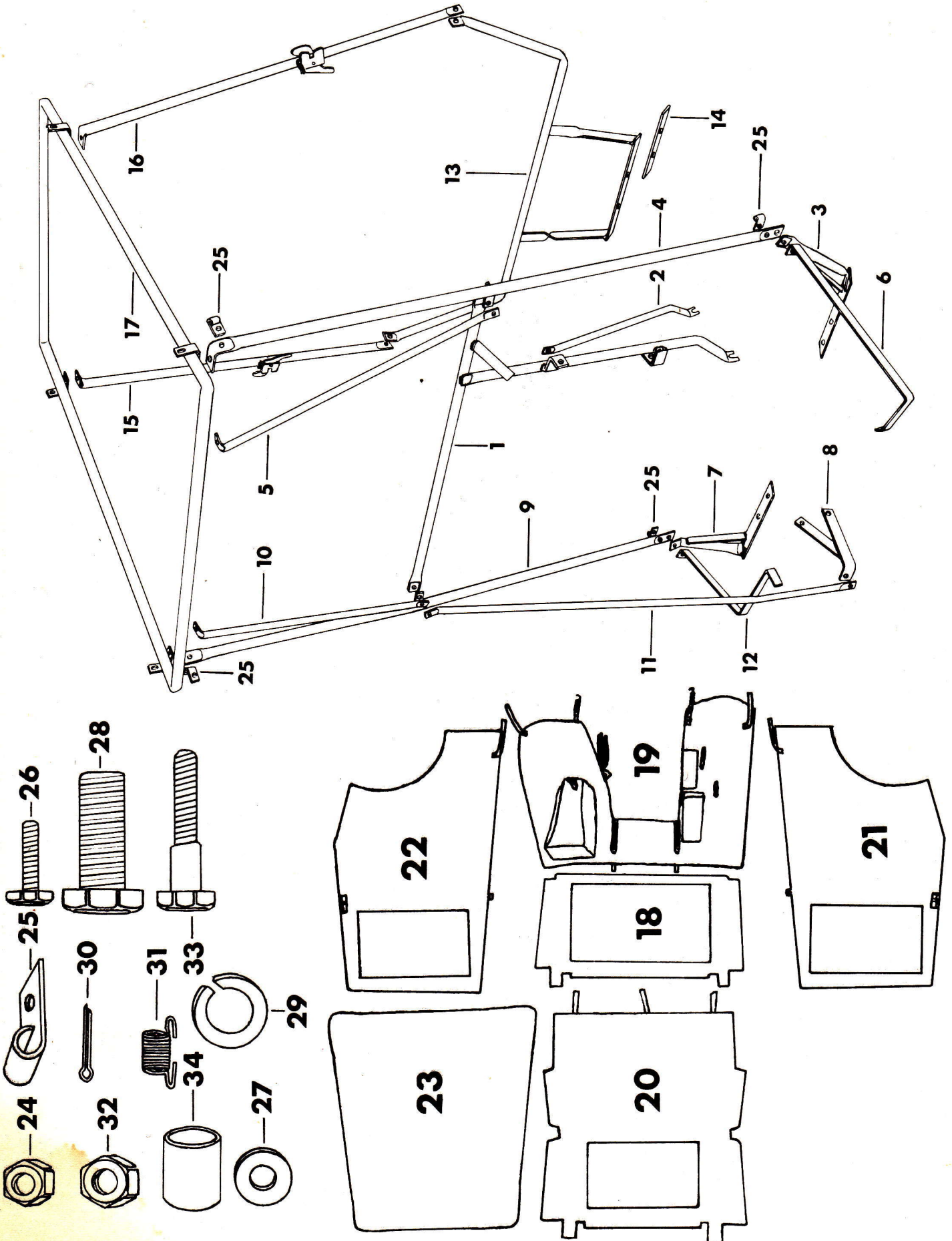

## HARDTOP VINYL CAB—MODEL NO. 922.261660

### CARTON CONTENTS

KEY NO.	QUAN.	PART NO.	PART NAME
1	1	7870	FRONT PANEL FRAME
2	1	7869	FRONT PANEL FRAME BRACE, left hand
3	1	7867	FOOT, left hand
4	1	4044	FRONT CORNER POST, left hand (straight/screw)
5	1	5631	TOP BRACE, left hand
6	1	6450	FOOT GUARD, left hand
7	1	7866	FOOT, right hand
8	1	7878	BRACKET, right hand front panel brace
9	1	4043	FRONT CORNER POST, right hand (straight/screw)
10	1	5630	TOP BRACE, right hand
11	1	7868	FRONT PANEL FRAME BRACE, right hand
12	1	7672	FOOT GUARD, right hand
13	1	7871	REAR ATTACHING BRACKET
14	1	7872	HITCH SPACER
15	1	6548	REAR CORNER POST, right hand
16	1	6549	REAR CORNER POST, left hand
17	1	5632	TOP FRAME
18	1	7357	WINDSHIELD
19	1	7873	FRONT PANEL VINYL
20	1	7874	REAR CURTAIN
21	1	7875	DOOR, right hand
22	1	7876	DOOR, left hand
23	1	5548	FIBERGLASS TOP
	1	7880	OWNER'S MANUAL (not shown)
	1	7877	PARTS BAG (contents listed below)
24	26	730	1/4" - 20 NUT, lock
25	4	15	DOOR HINGE
26	26	788	1/4"-20 x 3/4" CAPSCREW, hex
27	4	3951	1/4" FLAT WASHER
28	2	3316	1/2"-13 x 1 1/4" CAPSCREW, hex
29	2	3317	1/2" SPLIT LOCKWASHER
30	1	7879	1/8" x 1" COTTER PIN
31	2	7781	DOOR LATCH SPRING
32	1	729	5/16"-18 NUT, lock
33	1	2187	5/16"-18 x 1 1/2" CAPSCREW, hex
34	1	7626	9/16" Dia. x 3/4" long SPACER

**Sears**

# OWNER'S MANUAL

**MODEL NO.  
922.261660**

The Model Number is located in the fiberglass top, on the inside of the top.

All parts listed herein may be ordered from any SEARS, ROEBUCK AND CO. or SIMPSONS-SEARS LIMITED retail catalog store.

**WHEN ORDERING REPLACEMENT PARTS,  
ALWAYS GIVE THE FOLLOWING IN-  
FORMATION:**

1. The PART NUMBER
2. The PART DESCRIPTION
3. The MODEL NUMBER  
922.261660
4. The NAME OF ITEM  
HARDTOP VINYL CAB

If the parts you need are not stocked locally, your order will be electronically transmitted to a Sears Repair Parts Distribution Center for "expedited handling."

**Sears, Roebuck and Co., Chicago, Ill. 60684 U.S.A.  
and Simpsons Sears Limited, Toronto, Canada**

# Supplemental Instructions

For

Glass Windshield

&

Hand Operated Wiper

# SUPPLEMENTAL INSTRUCTIONS

FOR GLASS WINDSHIELD INSTALLATION

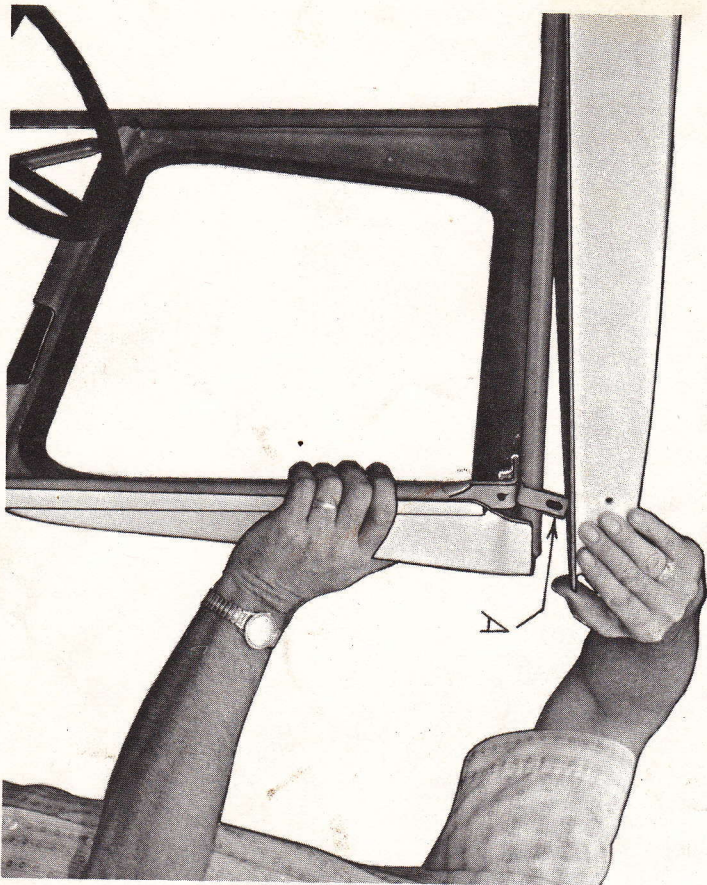

Place fiberglass TOP over the TOP FRAME and leave loose for now. Make sure all four clips welded to the TOP FRAME which will be used to fasten together the TOP FRAME and the fiberglass TOP have been bent FORWARD approximately 1/4", pointed out at "A". They are bent easier by using a large adjustable wrench, or a 3/4" open end wrench.

*Purchased from Sears Oct. 30, 1982  
installed same day.*

Manufactured for Sears, Roebuck & Co. by:

ORIGINAL TRACTOR CAB CO., INC.  
Arlington, Indiana 46104

CARTON CONTENTS

- (1) #5975 GLASS WINDSHIELD (in fiberglass frame)
- (1) #5976 ZIPPER STRIP

INSTALLATION INSTRUCTIONS

1. Remove plastic windshield from your cab.
2. Remove the two braces which go from the ends of your cross bar (3) to the front part of the top frame (6).
3. Remove all four bolts from the fiberglass top (16), and raise the top (front end) up and slide it toward rear, as shown in FIG. 1.

Zipper the black strip (1A), which was in the glass windshield package, to the top edge of your vinyl cab front panel (1B), and lay it on top of the cab cross bar (3), as shown in FIG. 1.

5. Place the bottom edge of the windshield (1) onto the cross bar (3) and on top of zipper strip (1A), as shown in FIG. 1., push the top of windshield back against front part of top frame (6), and pull fiberglass top (16) forward and force it down, so that it will hold the windshield frame in place.

6. Re-insert four bolts which will fasten fiberglass top to the top frame, and adjust top so that it will fit the top of the closed and locked doors properly before tightening the bolts.

NOTE: Install WINDSHIELD WIPER as shown on reverse side of this sheet.

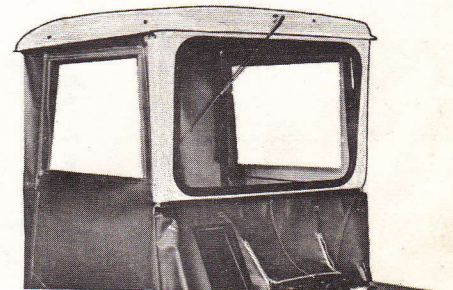
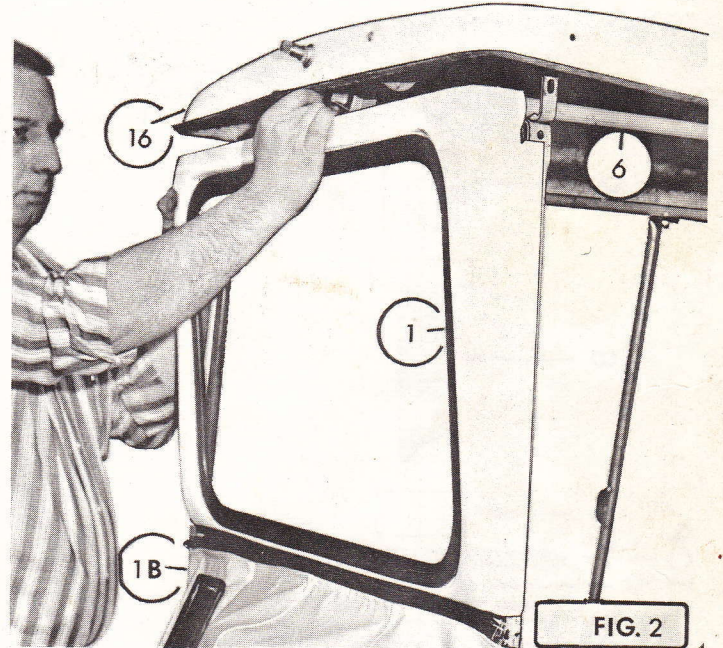
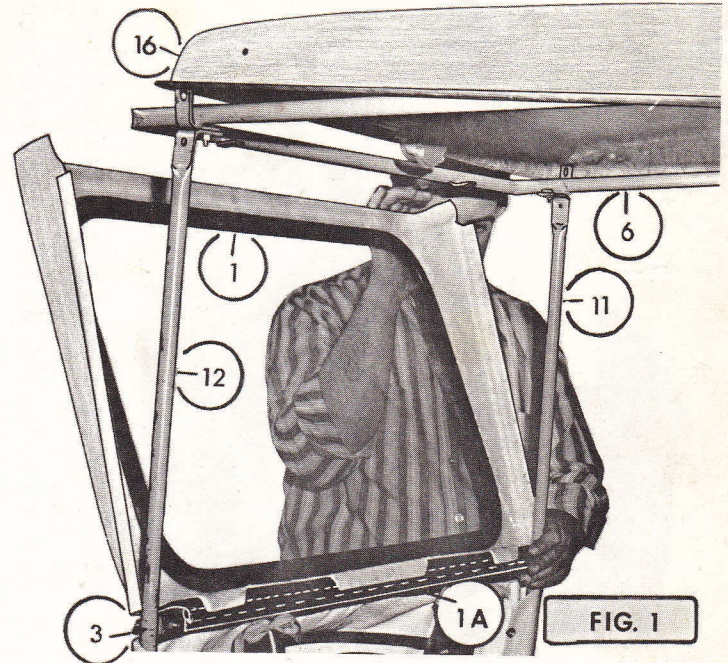

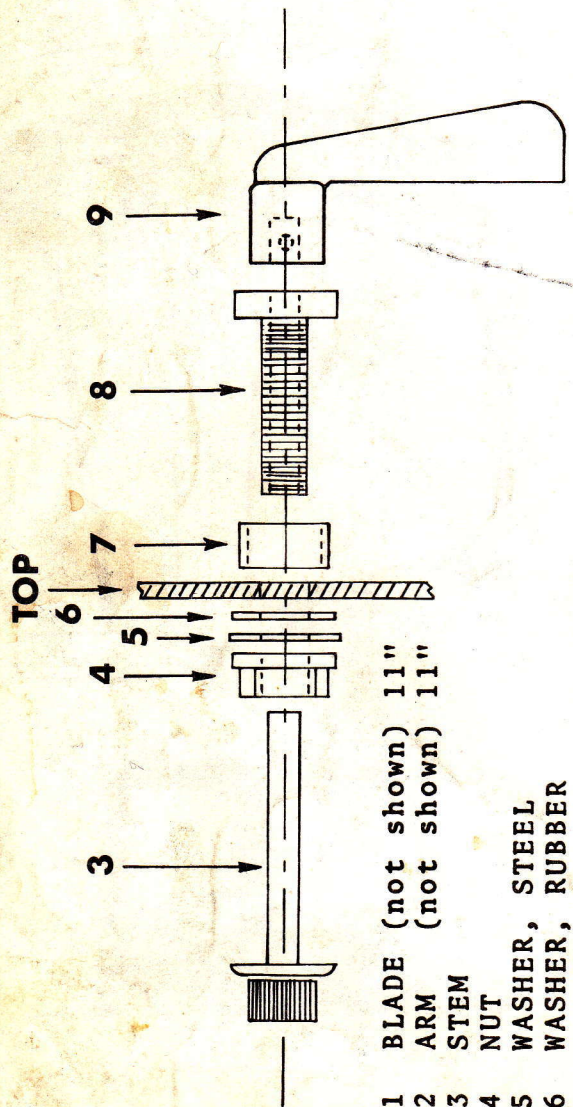

- 1 BLADE (not shown) 11"
- 2 ARM (not shown) 11"
- 3 STEM
- 4 WASHER, STEEL
- 5 WASHER, RUBBER
- 6 FIBERGLASS TOP
- 7 #7546 SPACER (3/4" O.D. x 3/8" long)
- 8 THREADED BODY
- 9 HANDLE

**FOR HAND WINDSHIELD WIPER MOUNTING**

**CENTER CROSSWISE ON FRONT OF TOP**

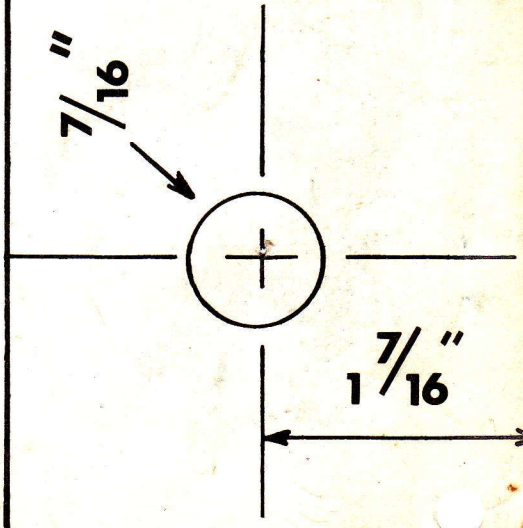

1. Place this template against the front of the TOP as shown, with the location for the 7/16" hole centered crosswise.
2. Mark the TOP and drill a 7/16" hole thru the front of the TOP.
3. Place the SPACER (7) onto the THREADED BODY (8) and from inside the cab, insert the THREADED SPACER (8) thru the hole in the TOP, add a RUBBER WASHER, then add a STEEL WASHER, then add the NUT. Tighten the NUT securely.
4. From outside the cab, insert the STEM (3) thru the THREADED BODY and add the HANDLE to the other end of the STEM inside the cab. Use a small screw driver to tighten the set-screw of the HANDLE to the STEM.
5. With the HANDLE hanging straight down, attach the ARM to the splined stem on the outside of cab, with the ARM also hanging straight down. Add the WIPER BLADE to the ARM.